

**USER AND MAINTENANCE MANUAL****MOTOR COMPRESSOR****D** *185T4F*

	<b>USER AND MAINTENANCE MANUAL</b>	Date:	06/02/2025
		Code	MAN D185T4F ENG
<b>Motor compressor : D185T4F</b>		Revision	05

Dear Customer,

Thank you for purchasing the ELGI Portable compressor. It is designed and manufactured to the highest standards to ensure superior performance, ease of use, and simple installation.

For any information, you can contact our customer service at the following address:.

**ELGI PORTABLE COMPRESSORS**

4610 Entrance Drive STE A

Charlotte, NC 28273

704-523-4123

[portableservice@elgi.com](mailto:portableservice@elgi.com)

[portablesales@elgi.com](mailto:portablesales@elgi.com)

[portableparts@elgi.com](mailto:portableparts@elgi.com)



	<b>USER AND MAINTENANCE MANUAL</b>	Date:	06/02/2025
		Code	MAN D185T4F ENG
<b>Motor compressor : D185T4F</b>		Revision	05

### FOREWORD

These service instructions are designed to enhance your understanding of the purchased machinery and its proper use.

For brevity, detailed technical descriptions of certain motor and axle operations have been omitted, as they are covered in the user and maintenance manuals provided by their respective manufacturers.

This manual contains essential guidelines for the safe, efficient, and cost-effective operation of the machine. Adhering to these instructions helps prevent hazards, avoid unnecessary costs and downtime, and extend the machine's lifespan.

Users must follow all service instructions and safety measures outlined in this manual. In addition to these guidelines, all relevant workplace safety regulations and accident prevention measures applicable in the installation location must be observed.

Carefully read and follow the instructions in this manual. Unauthorized disclosure, duplication, or reproduction is strictly prohibited without prior written consent from the Manufacturer. Violations, particularly those benefiting competing companies, will be pursued in accordance with the law.





**USER AND  
MAINTENANCE MANUAL**

Date:	06/02/2025
Code	MAN D185T4F ENG
Revision	05

**Motor compressor : D185T4F**

**TABLE OF CONTENTS**

**1 General.....7**

1.1 Definitions.....7

1.1.1 Qualified personnel .....7

1.1.2 Hazard.....7

1.1.3 Hazardous area.....7

1.1.4 Exposed person .....7

1.1.5 Operator .....7

1.1.6 Risk .....7

1.1.7 Guard .....7

1.1.8 Protection Equipment.....7

1.1.9 Expected use .....7

1.1.10 Reasonably expectable incorrect use .....7

1.1.11 Component.....7

1.1.12 Control Device.....7

1.1.13 Safety interlock.....8

1.1.14 Manufacturer .....8

1.2 Machinery Identification .....8

1.3 Harmonized Technical Standards .....9

1.4 General description of the machinery .....10

**2 Technical features of the machinery .....11**

2.1 General technical characteristics .....11

2.2 Technical characteristics of the compressor.....11

2.3 Technical characteristics of the engine .....12

2.4 Technical characteristics of the electric battery .....12

2.5 Service temperatures .....12

**3 Symbols and warnings.....14**

3.1 Hazards.....14

3.2 Forbiddances.....15

3.3 Obligations and notices .....16

3.4 General notices .....16

**4 Use of the machinery .....18**

4.1 Permitted Use.....18

4.2 Prohibited Use.....18

4.3 Residual Risk .....19

**5 Personnel Levels and Qualifications.....20**

**6 Safety provisions.....21**

6.1 Safety Measures for Transport.....21

6.2 Safety Measures for Lifting .....22

6.3 Safety Guidelines for Towing (Road-Certified Compressors Only) .....23

6.4 Installation and Parking Requirements for the Motor Compressor .....24

6.5 Safety Measures for Maintenance .....25

6.6 Safety Precautions for the Toolbox.....26





**USER AND  
MAINTENANCE MANUAL**

Date:	06/02/2025
Code	MAN D185T4F ENG
Revision	05

**Motor compressor : D185T4F**

<b>7 Machinery components.....</b>	<b>27</b>
7.1 Chassis and Axle.....	27
7.2 Body .....	27
7.3 Engine .....	27
7.4 Compression Unit.....	27
7.5 Separator Tank.....	28
7.6 Bell and Flexible Coupling.....	28
7.7 Control Panel.....	28
<b>8 Electrical equipment of the machinery.....</b>	<b>29</b>
8.1 Operator Panel Tools .....	29
8.2 Operator Panel Pilot Lamps.....	30
8.3 Electronic Control Board .....	31
8.4 Reading Error Messages and Alarms on the DEEP SEA Control Board.....	37
8.3 Fuses.....	44
8.4 Lights (Road-Certified Version).....	45
<b>9 Hydraulic and pneumatic syStems .....</b>	<b>47</b>
9.1 Hydraulic Lubrication System.....	48
9.2 Pneumatic System .....	49
9.2.1 Automatic Engine RPM Adjustment.....	50
<b>10 Guidelines for the proper use of the motor compressor.....</b>	<b>51</b>
10.1 Pre-Start Checklist .....	51
10.2 Start-Up Procedure .....	53
10.3 During Operation.....	54
10.4 Stopping the Machine .....	55
10.5 Post-Stop Procedures .....	55
<b>11 Machine monitoring and testing .....</b>	<b>55</b>
11.1 Engine Speed Monitoring and Testing.....	55
11.1.1 Maximum Engine Speed Control System .....	56
11.2 Air Pressure Monitoring and Control for the Compressor.....	56
11.3 Minimum Air Pressure Monitoring and Control for the Compressor .....	57
<b>12 Safety devices.....</b>	<b>58</b>
12.1 Safety Valve Verification .....	58
<b>13 Maintenance .....</b>	<b>59</b>
13.1 Routine Maintenance .....	59
13.2 Maintenance Program .....	60
13.2.1 Service Kit .....	61
13.3 Torque Specifications for Screws and Bolts .....	63
13.4 Maintenance Procedures .....	64
13.4.1 Inspecting and Cleaning Air Filters and Intake .....	64
13.4.2 Checking the Electrical Battery .....	65
13.4.3 Fuse Replacement .....	66





**USER AND  
MAINTENANCE MANUAL**

<b>Date:</b>	<b>06/02/2025</b>
<b>Code</b>	<b>MAN D185T4F ENG</b>
<b>Revision</b>	<b>05</b>

**Motor compressor : D185T4F**

13.4.4	Cleaning the Radiator and Cooler.....	66
13.4.5	Cooling Liquid Dosage Percentage .....	66
13.4.6	Checking and Cleaning the Oil Recovery Orifice.....	68
13.4.7	Fuel Tank Drainage.....	68
13.4.8	Replacing the Diesel Filter and Pre-Filter .....	69
13.4.9	Checking the Wheel Bolt Tightness .....	69
13.4.10	Compressor Oil Filter Replacement.....	70
13.4.11	Compressor Oil Replacement.....	71
13.4.12	Checking the Oil Mist Separator .....	72
13.4.13	Replacing the Oil Separator Filter.....	72
13.4.14	Engine Inspection and Maintenance.....	73
<b>14</b>	<b>Spare parts .....</b>	<b>73</b>
<b>15</b>	<b>Faults and troubleshooting .....</b>	<b>74</b>
<b>16</b>	<b>Machine disposal and decommissioning.....</b>	<b>76</b>
16.1	Dismantling Instructions .....	76
<b>17</b>	<b>Machine decommissioning.....</b>	<b>76</b>
<b>18</b>	<b>Waste management .....</b>	<b>77</b>
18.1	Special Waste .....	77
18.2	Toxic And Hazardous Waste.....	77
18.3	Temporary Storage .....	77
18.4	Container Specifications .....	77
18.5	Registration and Documentation Requirements .....	77
<b>19</b>	<b>ELGI product warranty information .....</b>	<b>78</b>
19.1	Warranty Term and Conditions .....	78



## 1 GENERAL

### 1.1 Definitions

The key definitions included in this manual are provided below.

#### 1.1.1 QUALIFIED PERSONNEL

"Qualified personnel" refers to individuals who are knowledgeable about the installation, assembly, repair, and servicing of the machinery and possess the necessary technical qualifications. These qualifications may include: Technical training that ensures compliance with safety standards, particularly regarding hazards such as electrical currents, pressure circuits, etc.

A technical background or specialized training related to the user and maintenance procedures of the machinery in a safe manner.

Training in basic first aid.

#### 1.1.2 HAZARD

A potential cause of injury or health hazards.

#### 1.1.3 HAZARDOUS AREA

Any area within or near the machinery where a person's presence poses a risk to their health and safety.

#### 1.1.4 EXPOSED PERSON

Any person who is fully or partially present in a hazardous area.

#### 1.1.5 OPERATOR

The person or people responsible for installing, operating, adjusting, cleaning, repairing, moving, or maintaining the machinery.

#### 1.1.6 RISK

Combination of the likelihood and severity of an injury or damage to health which may arise in a hazardous situation.

#### 1.1.7 GUARD

A component of the machinery designed to provide protection through a physical barrier.

#### 1.1.8 PROTECTION EQUIPMENT

A device, distinct from a guard, that reduces risk either independently or in combination with a guard.

#### 1.1.9 EXPECTED USE

The use of the machinery in compliance with the user's information.

#### 1.1.10 REASONABLY EXPECTABLE INCORRECT USE

The use of the machinery in a manner different from that specified in the user instructions, but which may result from reasonably foreseeable human behavior.

#### 1.1.11 COMPONENT

A component of the electrical or pneumatic system, typically defined by its function, but applicable in various uses.

#### 1.1.12 CONTROL DEVICE

A device incorporated into a control circuit to regulate the operation of the system.



	<b>USER AND MAINTENANCE MANUAL</b>	Date:	06/02/2025
		Code	MAN D185T4F ENG
<b>Motor compressor : D185T4F</b>		Revision	05

### 1.1.13 SAFETY INTERLOCK

Mechanical, electrical or other device whose purpose is to prevent the parts of the machinery from operating in specified conditions (generally, until the guard is closed)

### 1.1.14 MANUFACTURER

Physical or legal person who designed and/or develops machinery or partly-completed machinery which is subject of this directive and who is liable for the compliance of the machinery or partly-completed machinery with this directive as related to its marketing with his/her name or brand, or for personal use. In absence of a Manufacturer as defined above, the Manufacturer shall be considered the physical or juridical person who markets or puts into service machinery or partly-completed machinery.

## 1.2 Machinery Identification

The identification nameplate is affixed to the motor compressor chassis.

This nameplate displays the manufacturer's information, machinery designation, model number, serial number, and year of manufacture.

For any spare parts requests or technical assistance, please refer to the details on the nameplate, ensuring that the machinery's model number and serial number are always provided.

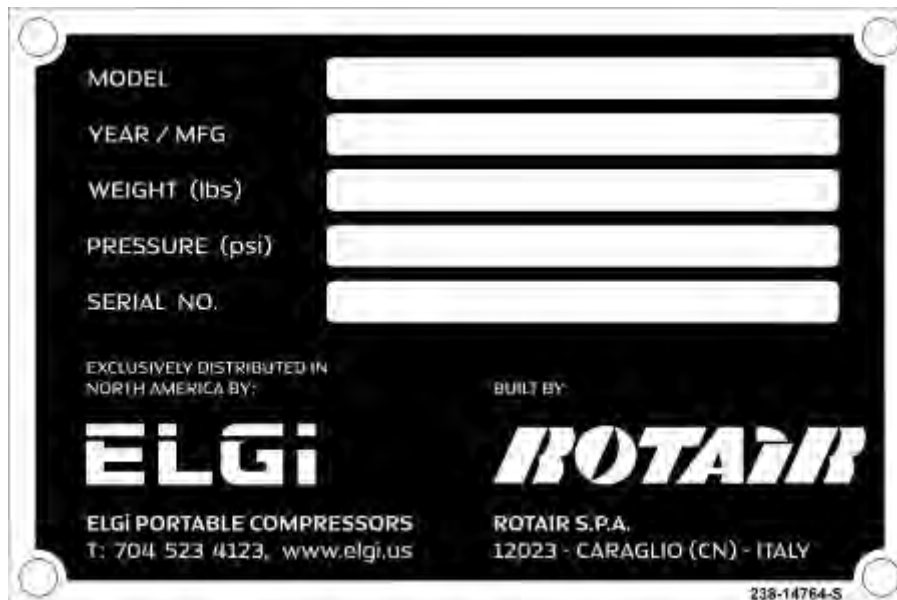

Figure 1.2-1 Nameplate of motor compressor D185T4F



### 1.3 Harmonized Technical Standards

The machinery has been designed and developed in compliance with the provisions contained in the technical standards reported herein under:

UNI EN ISO 12100	Safety of machinery -General design principles - Risk assessment and risk reduction.
UNI EN ISO 13857	Safety of machinery– Safety distances to prevent from reaching the hazardous areas with the upper or lower limbs.
UNI EN ISO 13850	Safety of machinery - Emergency stop system, functional aspects
CEI EN 62061	Safety of machinery - Functional safety of the programmable electrical and electronic control systems as related to safety
CEI EN 60204-1	Safety of machinery - Electrical equipment of the machineries. Part I: General rules.
UNI EN 983	Safety of machinery. Safety requirements relevant to systems and related components for hydraulic and pneumatic transmission. Pneumatics.
UNI EN 349	Safety of machinery - Minimum openings to prevent the crushing of parts of the human body.
D. LGS. January 27th 2010 no.17	Implementation of Directive 2006/42/CE relevant to machinery, which modifies directive 95/16/CE relevant to elevators.
UNI EN ISO 14121-1	Safety of machinery - Risk assessment. General principles
UNI EN ISO -TR 14121-2	Safety of machinery - Examples



#### **Machine directive 2006/42/CE.**

##### Article 7. Presumption of conformity and harmonized standards

1. The Member States deem that the machinery provided with the “CE” marking and accompanied by the CE declaration of conformity, whose elements are provided for in Annex II, Part 1, Section A, comply with the provisions of this directive.
2. The machinery manufactured in compliance with an authorized standard, whose reference has been published on the Official Journal of the European Union is assumed to be compliant with the essential health and safety requirements covered by such harmonized standard.
3. The Commission published the references of the harmonized standards in the Official Journal of the European Union.
4. The Member States shall take the appropriate measures to allow the social partners influencing - at national level - the development and control process of the harmonized standards.



	<b>USER AND MAINTENANCE MANUAL</b>	Date:	06/02/2025
		Code	MAN D185T4F ENG
<b>Motor compressor : D185T4F</b>		Revision	05

#### 1.4 General description of the machinery

The machinery described in this manual is the D185T4F motor compressor.

This motor compressor is designed to generate a specific amount of compressed air (measured in liters per minute) using a diesel engine as the primary energy source.

Pneumatic energy is used in various applications, powering "pneumatic" tools, accessories, and equipment, such as demolition hammers, drilling hammers, vibrators, drilling machines, rammers, coating machines, and more. Each tool or accessory has its own compressed air consumption, measured in liters per minute.

The optimal coupling between the compressor and the tool is achieved when the tool's compressed air consumption does not exceed 85% of the air produced by the compressor. Additionally, it should be noted that the air consumption of the tool may increase over time as the tool wears.

Maintaining the correct compressor-to-tool ratio ensures the machinery operates under optimal conditions, promoting longevity and high performance.

An oversized tool, on the other hand, can create unfavorable operating conditions for the machinery and prevent it from reaching its full performance, as it may not have access to the necessary amount of compressed air.

This machinery is designed to operate within an ambient temperature range of -10°C (14°F) to +40°C (105°F).



## 2 TECHNICAL FEATURES OF THE MACHINERY

The general technical characteristics of the machinery are reported hereinafter.

### 2.1 General technical characteristics

	<b>D185T4F</b>
<b>DESCRIPTION</b>	<b>TECHNICAL VALUES AND DATA</b>
Length (Body)	1835 mm – 72.20 inches
Width (Body)	1030 mm – 40.55 inches
Height (Body)	995 mm – 39.20 inches
Mass (Body)	850 kg – 1874 lbs
Compression system	Screw single-stage
Fuel tank capacity	90 lt – 23.75 gal

### 2.2 Technical characteristics of the compressor

	<b>D185T4F</b> (Standard version - 100 psi)
<b>DESCRIPTION</b>	<b>TECHNICAL VALUES AND DATA</b>
Service pressure	7 bars – 100 psi
Minimum pressure	5 bars – 73 psi
Max. pressure	8.5 bars – 123 psi
Rated payload at service pressure	5200 lt/min–185 CFM
Cooling typology	Specific oil for screw compressors (*)
Hydraulic system capacity	9 lt – 2.4 gal
Separator tank capacity	20 lt – 5.3 gal

(\*) For the recommended oil see Paragraph 13.4.13

	<b>D185T4F</b> (Dual Pressure version – 100/150 psi)
<b>DESCRIPTION</b>	<b>TECHNICAL VALUES AND DATA</b>
Service pressure	7 bars – 100 psi      10 bars – 150 psi
Minimum pressure	5 bars – 73 psi
Max. pressure	8.5 bars – 125 psi      11.5 bars – 165 psi



### 2.3 Technical characteristics of the engine

DESCRIPTION	D185T4F TECHNICAL VALUES AND DATA
Engine brand	Kohler / Lombardini
Type	KDI-1903-TCR – Turbo - intercooler
Number of cylinders	3
Fuel	Diesel
Cooling	By liquid
Cooling system capacity	14 lt – 3.7 gal
Emissions	Stage IIIB - Tier 4 final
Engine oil tank capacity	9 lt – 2.4 gal
	<b>D185T4F (Standard version - 100 psi)</b>
Max. rotation speed	2450 r.p.m.
Min. rotation speed	1700 r.p.m.
	<b>D185T4F (Dual Pressure version – 100/150 psi)</b>
Max. rotation speed	2250 r.p.m.
Min. rotation speed	1700 r.p.m.

### 2.4 Technical characteristics of the electric battery

DESCRIPTION	TECHNICAL VALUES AND DATA
Rated voltage	12 Vcc
Capacity	100 Ah
Discharge current	750 A

### 2.5 Service temperatures

DESCRIPTION	TECHNICAL VALUES AND DATA
Minimum ambient temperature limit	-10°C [14°F]
Maximum ambient temperature limit	+40°C [105°F]
Humidity limits	≤ 50% (à +40°C-105°F)





**USER AND  
MAINTENANCE MANUAL**

<b>Date:</b>	<b>06/02/2025</b>
<b>Code</b>	<b>MAN D185T4F ENG</b>
<b>Revision</b>	<b>05</b>

**Motor compressor : D185T4F**

NOTES: \_\_\_\_\_



### 3 SYMBOLS AND WARNINGS

The pictograms and main warning for the operators are reported herein under and indicated by the following denominations and symbols:

#### 3.1 Hazards

**WARNING**

The pictogram calls the attention of specific provisions in order to prevent damage.

**WARNING FOR ELECTRICAL HAZARD**

The pictogram calls the attention of specific provisions in order to prevent damage.

**WARNING FOR CRUSHING HAZARD**

The pictogram calls the attention on a likely hazardous situation with risk of crushing the upper limbs.

**WARNING HAZARD OF ORGANS IN MOTION**

The pictogram calls the attention to the hazard of organs in motion.

**WARNING ON RISK OF SCALDING OR HAZARD DUE TO HIGH-TEMPERATURE ELEMENTS**

The pictogram calls the attention on the hazard of high-temperature elements and risk of scalding.



**WARNING:  
OVERHANG  
ING LOADS**

**OVERHANGING LOAD WARNING**

The pictogram calls the attention to the hazard due to the presence of overhanging loads

**WARNING OF THE PRESENCE OF PRESSURE VESSELS**

The pictogram calls the attention to the presence of pressure vessels.



### 3.2 Forbiddances

**FORBIDDANCE TO REMOVE THE PROTECTION EQUIPMENT AND THE GUARDS**

The pictogram calls the attention on the forbiddance to remove protection equipment such as fixed, movable, interlock guards or to tamper with photocells or photocell barriers.

**FORBIDDANCE TO PERFORM CLEANING OR MAINTENANCE WHEN THE MACHINERY IS IN MOTION**

The pictogram calls the attention on the forbiddance to perform cleaning or maintenance operations with components in motion.

**FORBIDDANCE TO TRANSIT UNDER OVERHANGING LOADS**

The pictogram calls the attention on the forbiddance to transit under overhanging loads.

**FORBIDDANCE TO START THE MACHINERY WHEN THE HOOD IS OPEN**

### 3.3 Obligations and notices

**NOTICES**

This symbol recommends to consult the manual before undertaking a given action.

**OBLIGATIONS TO USE THE PPE (PERSONAL PROTECTION EQUIPMENT)**

The pictogram calls the attention on the obligation to use the personal protection equipment.

**NOTICES**

This symbol highlights that the description involves significant parts, since they may cause severe mechanical and electrical damage and malfunctions if the relevant standards are not complied with. It is recommended to comply with the information contained in this manual and with the law provisions in force as related to health and safety at the workplace.

**HIGHLIGHTING OF THE HOOKING POINT TO LIFT THE MACHINERY.****OBLIGATION TO USE THE SUPPORT FOOT, THE PARK BRAKE AND WHEEL LOCKING WEDGES.**

### 3.4 General notices

This manual provides the user and routine maintenance instructions for the machinery. Unless otherwise specified, operational and maintenance tasks are considered "specialized," meaning they should only be performed by a qualified technician.

Before performing any operation on the machinery, carefully read this manual.

ELGI disclaims any responsibility for operations conducted in violation of the instructions outlined in this document.

Before using the machinery, thoroughly review this document and adhere to all applicable safety laws, regulations, and standards.

This manual and the accompanying documents are integral to the machinery they pertain to and must always be kept with the machinery, even if it is transferred to another user. Therefore, it is essential to preserve these materials for future reference.

This manual and the associated documents are specific to the machinery they were created for.



**DO NOT use this manual and the accompanying documents to operate similar machinery, even if it is of the same brand or type.**

	<b>USER AND MAINTENANCE MANUAL</b>	Date:	06/02/2025
		Code	MAN D185T4F ENG
<b>Motor compressor : D185T4F</b>		Revision	05

ELGI is available to assist customers with any additional information. Please provide the machinery details, including type, model, and code, as listed on the identification nameplate. Any specific data not mentioned in this text can be found in the chapter "Technical Characteristics of the Machinery" and the technical annexes of this user and maintenance manual.

This manual thoroughly describes:

- The information relevant to towing, lifting and parking of the machinery;
- The general rules and recommendations useful for routine and extraordinary maintenance;
- The modalities to identify and order the spare parts.

*Remark: the instructions for the appropriate use of the engine are described in the manual drafted by the engine manufacturer.*

This manual must be preserved with care, in its folder, far from sources of humidity, heat and sun rays, so that it can be consulted at any time by both the personnel appointed to the use and by those who need to perform routine and extraordinary maintenance.

This machinery has been exclusively designed and manufactured to deliver compressed air in the conditions stated by the Manufacturer. Every other utilization not mentioned in the "expected uses" shall relieve the manufacturer from any liabilities, which will be at full charge of the user.

"Approved purpose" assumes compliance with the provisions reported hereinafter and related to the appropriate use and maintenance, as well as to the transport of the unit.

All the accident prevention regulations and standards in force need to be complied with as well, besides complying with the general rules in terms of safety and occupational medicine which are governed by the legislation in force.

The manufacturer declines any responsibility in case of changes made on the machinery without its authorization.

Before commissioning, the buyer must ascertain that ANY equipment or machinery, components and protection installations that are not part of the supply of this machinery comply with Machine Directive 2006/42/CE and to the other applicable European Directives (2006/95/CE - 2004/108/CE, etc.).

## 4 USE OF THE MACHINERY

### 4.1 Permitted Use

The machinery described in this manual is the D185T4F motor compressor, designed for outdoor operation. This motor compressor generates a specific quantity of compressed air (measured in liters per minute) using a diesel engine as its primary energy source.

Pneumatic energy is utilized in various applications where pneumatic tools, accessories, and equipment are required, such as demolition hammers, drilling hammers, vibrators, drilling machines, rammers, and coating machines. Each tool or accessory has its own compressed air consumption, measured in liters per minute.

For optimal performance, the tool's compressed air consumption should not exceed 85% of the air generated by the compressor. Additionally, the air consumption of the tool will increase over time due to wear.

Maintaining the correct compressor-to-tool ratio ensures optimal machinery performance, promoting durability and efficiency.

Using an oversized tool can negatively impact the machinery's operation and prevent the tool from reaching its full performance potential due to insufficient compressed air supply.

This machinery is designed to operate within an ambient temperature range of -10°C (14°F) to +40°C (105°F).



**WARNING:** *It must be highlighted that the compressed air generated by this unit may contain some very fine traces of oil, therefore it is not appropriate to be utilized with those systems that call for fully oil-free air (e.g.: food processing and pharmaceutical industry, transports of flours and powders, cement, etc...).*

### 4.2 Prohibited Use

It is not allowed to use the machinery for other processes than those which are mentioned in the section above. ELGI declines any responsibility as related to injuries or accidents due to lack of compliance with the specific provisions for use.

### 4.3 Residual Risk



Avoid standing in front of the compressed air discharge points. Direct exposure to the air jet can cause moderate injuries due to the high pressure and velocity of the compressed air.



This machine is designed for outdoor operation due to the presence of the engine and its exhaust emissions.



**Operating the machine indoors, especially in environments containing vapors or mixtures of corrosive or explosive gases, is strictly prohibited.**

When performing demolition, drilling, sandblasting, or any other dust-generating operations, the tool must be connected to the compressor using a pressure-resistant hose of sufficient length. This ensures the machinery remains away from the work area, preventing dust from clogging both the exhaust filters and the radiator, which cools the lubrication and cooling liquids. Additionally, a skilled operator should position the machinery on the leeward side of the work area to minimize dust exposure.

The machinery is designed to operate with the hood closed. Keeping it open while the engine is running is strictly prohibited, as this would not only increase harmful noise emissions but also disrupt the necessary internal ventilation required for proper compressor operation.

Before starting the machine, ensure the hood is fully closed and that the hinges on the rear side of the motor compressor are securely fastened.



Figure 4.3-1 Engine compartment hood closing hinges

Even selecting the hoses to connect the machinery to the tool, make sure that they are sized as appropriate, taking into account their length, the volume of air which needs to pass through them and the service pressures: if the hoses show a too small diameter or excessive length, the air flow would interrupt, with subsequent loss of load and poor performance of the tool.

The hoses which convey compressed air to and from the machinery to the tool, or to any device applied, is to be provided with a service valve located at the end which is connected to the tool; the service valve shall be held closed during the connection of the hoses to both the machinery and the tool in order to prevent an inappropriate opening of the service valve on board the machine from generating strong flickering of the piping, which may cause injuries. Before disconnecting any hose, make sure there is no pressure inside.



## USER AND MAINTENANCE MANUAL

Date:	06/02/2025
Code	MAN D185T4F ENG
Revision	05

**Motor compressor : D185T4F**

### 5 PERSONNEL LEVELS AND QUALIFICATIONS

All operations on the machinery must be carried out exclusively by qualified, trained, and informed personnel.



"Qualified personnel" refers to individuals who, based on their profession, have acquired the necessary experience, training, and knowledge of applicable standards and accident prevention measures. These personnel, appointed by machinery safety managers, must be capable of performing required tasks while identifying and mitigating potential hazards.

Only properly trained or instructed personnel should be assigned to these tasks. Clearly define the competencies required for fine-tuning, maintenance, and repair operations. Establish the responsibilities of personnel operating the equipment through precise written instructions and authorize them to refuse directives from third parties if they conflict with safety regulations and standards.

Ensure that only designated personnel perform these activities.

Work on the machinery's electrical systems must be conducted solely by qualified electricians or individuals with appropriate electro-technical expertise, in compliance with applicable electrical regulations and standards.

Mechanical and pneumatic maintenance must be performed exclusively by personnel from authorized service workshops.



## 6 SAFETY PROVISIONS

### 6.1 Safety Measures for Transport

Motor compressors that are not certified for towing must be loaded onto a suitable transport vehicle. The compressor must be securely fastened to the vehicle floor to prevent load shifting or imbalance during transport.

The unit is shipped attached to a support designed for handling with forklifts. This wooden platform facilitates secure anchoring to the transport vehicle's floor and prevents the load from sliding.

For safe transport, follow these steps:

- 1) Position the unit with the towing steer facing away from the cockpit of the transport vehicle.
- 2) Place the towing bar as shown in Figure 6.1-1.
- 3) Loop the securing ropes around the towing bar and tighten them using the transport vehicle's winches.
- 4) Set two wedges (Part A Figure 6.1-1) on each wheel, attaching them to the vehicle floor, in order to prevent the machinery from moving. Utilize wedges of appropriate sizes, both in height and in width.
- 5) Travel at moderate speed.

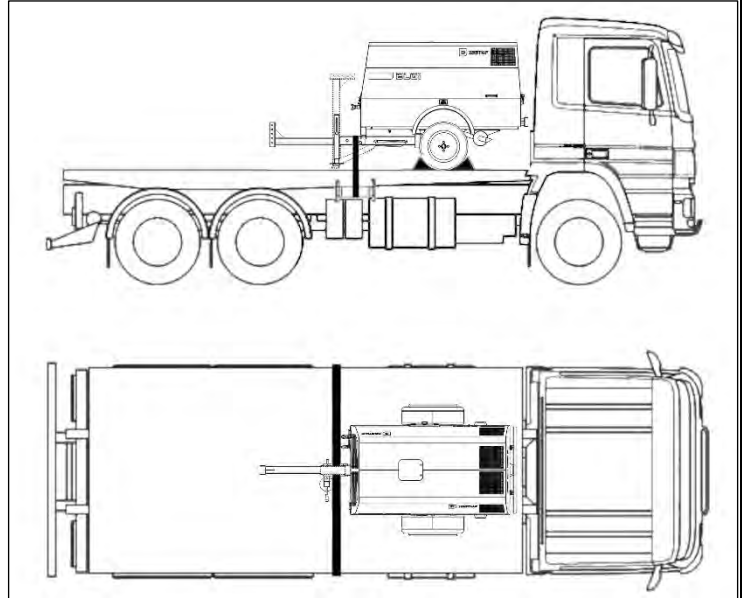

## 6.2 Safety Measures for Lifting



**Check the status of ropes and chains before starting the handling operations.**



A designated opening, protected by a rubber membrane, is located on the upper panel of the hood, providing easy access to the lifting hook.

Safe Lifting Procedure:

- 1) Ensure that the lifting equipment (crane, hoist, etc.) has a sufficient load capacity for the unit's weight and is properly maintained.
- 2) If lifting from a truck, deploy the vehicle's side anti-tilt stabilizers.
- 3) Securely attach the lifting device's hook to the designated lifting point on the compressor (refer to Figure 6.2-1).
- 4) Lift the unit slowly, avoiding sudden movements. During lateral displacement, minimize excessive swaying of the load.



Figure 6.2-1 Instruction for lifting procedure



The user must periodically check the efficiency of the lifting equipment and replace it if it results to be no longer appropriate or safe.

No other hooking and lifting systems are allowed except those which are provided with the machine.



**This pictogram allows pointing out the hooking system to lift the machine.**

- 5) Always check - before handling - that there are no moving parts that may fall. In such case, attach them as appropriate.
- 6) In any case, always make sure that the machine is solidly fixed to the rope and balanced as appropriate.
- 7) Communicate the start-up of the maneuver as appropriate.
- 8) Never leave the maneuver area with an overhanging load
- 9) Do not stand or walk under the overhanging load.



**WARNING  
OVERHANGING  
LOADS**

**6.3 Safety Guidelines for Towing (Road-Certified Compressors Only)**

This paragraph concerns machines authorized for road circulation and therefore equipped with a regular homologation certificate.

For the appropriate towing of the motor compressor, comply with the following instructions:

- 1) Make sure that the large towing eyebolt or the ball coupler connection is compatible with the towing device located on the towing vehicle. Make sure that the vehicle is enabled to tow a weight equal to or greater than the one of the motor compressor you intend to tow.
- 2) Check the pressure of the tires.
- 3) Adjust the height of the eyebolt so that it corresponds to the towing vehicle hook; this can be obtained by acting on the articulate joints of the steer, until the towing bar that supports the eyebolt is as horizontal as possible.
- 4) Secure the articulations firmly using the appropriate levers, ensuring there is no clearance between the joint teeth.
- 5) Fit the safety chains.
- 6) Hook the trailer to the vehicle, connecting also the safety cable.
- 7) Release the park brake.
- 8) Lock the foot, or the support wheel, in the highest possible position, making sure that the wheel cannot rotate on itself, and remove the wheel if required.
- 9) Connect the lighting system by introducing the motor
- 10) Plug the compressor into the designated power outlet on the vehicle and ensure all lights (position, turn signal, brake, and number plate) are functioning properly.
- 11) If the machinery is equipped with an inertial brake, it will automatically disengage when reversing.
- 12) Periodically check the brakes and - if required - maintain them.

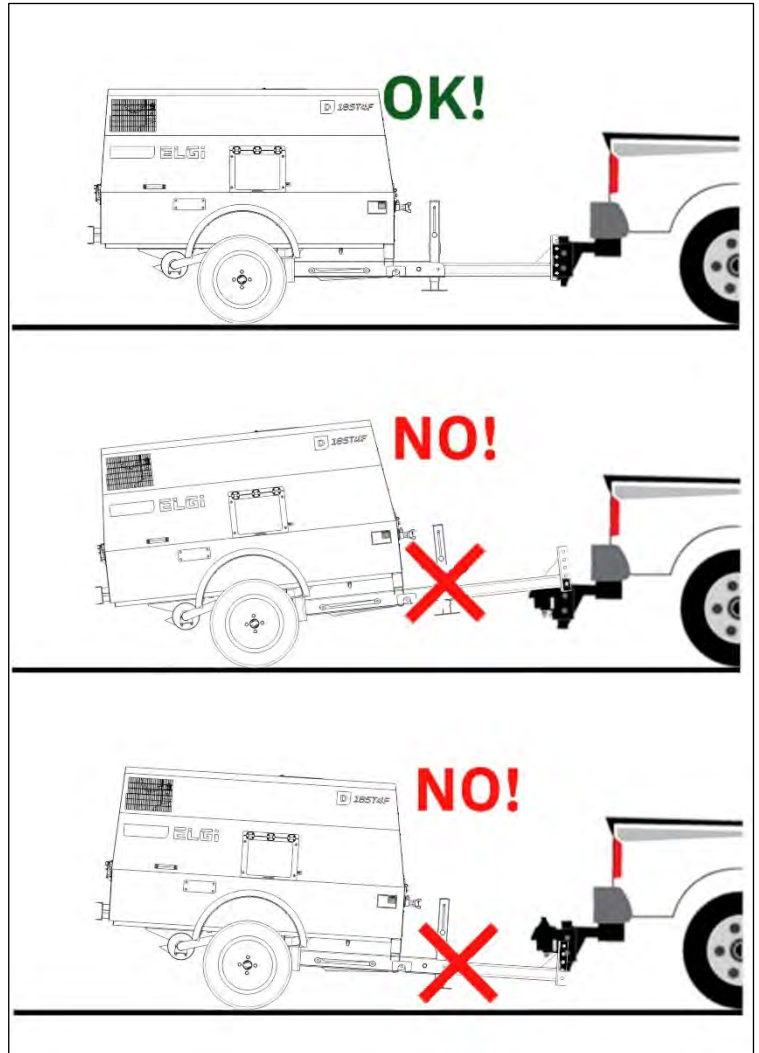

Figure 6.3-1 Instructions for safe towing

For the maintenance of the towing steer, of the axle and for the adjustment of the brakes, refer to the Manufacturer's manual enclosed to this documentation.



**WARNING:** To know the maximum speed for towing on the road, refer to the standards in force in the country where the towing is performed. On site or in a towing area, do not exceed the towing speed of 10 km/h.



#### 6.4 Installation and Parking Requirements for the Motor Compressor

Before disconnecting the drawing vehicle, or from the lifting hook, adjust the height of the support foot (Part B Figure 6.4-1) or the pivoting wheel, so that the motor compressor is in a horizontal position.

In case the machinery is on an incline, locate the wedges (Part A Figure 6.4-1) provided with the machine, in front of or behind the wheels to prevent any displacements, which might also occur during the working stage. Engage the park brake, if provided. It is forbidden to operate with the machine hooked to the towing vehicle.

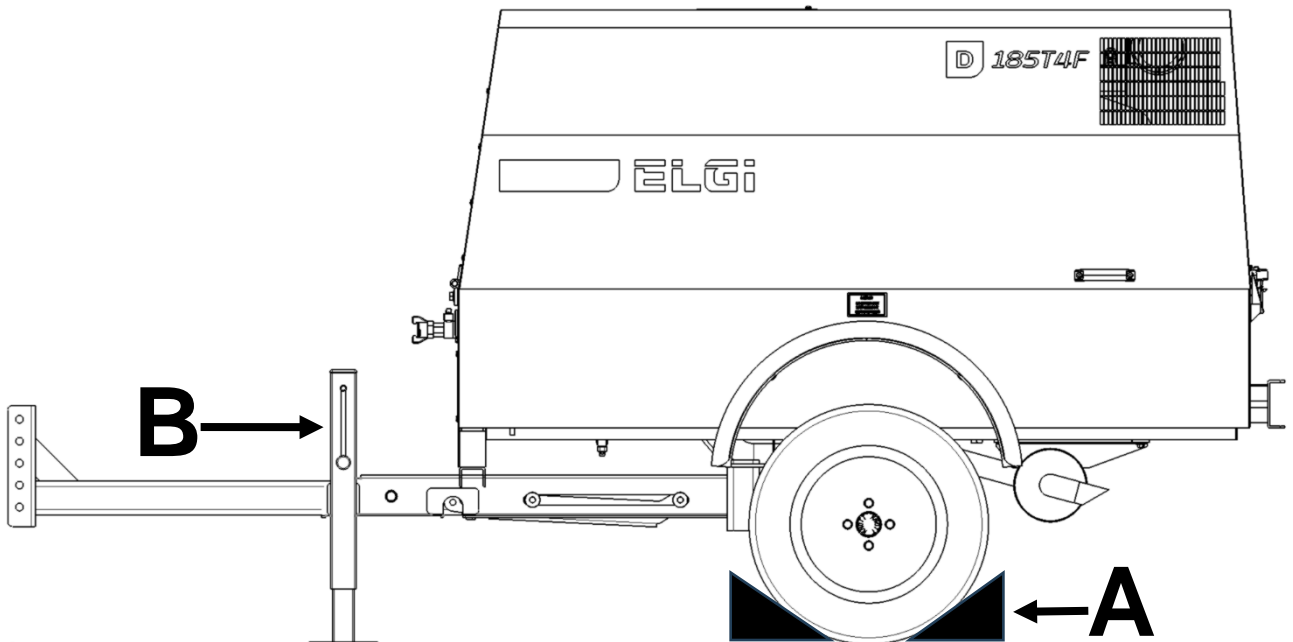



Figure 6.4-1 Instructions for parking and installation of the motor compressor



**When parking, it is mandatory to use the support foot and the wheel locking wedges.**

	<b>USER AND MAINTENANCE MANUAL</b>	Date:	06/02/2025
		Code	MAN D185T4F ENG
<b>Motor compressor : D185T4F</b>		Revision	05

## 6.5 Safety Measures for Maintenance

In order to perform the maintenance operations in safety conditions, the following provisions need to be complied with:

- Control and maintenance operations must be performed by qualified and specialized personnel familiar with the instructions in this manual. Qualified and specialized personnel are those who possess the necessary certifications, appropriate skills for the specific intervention, and have received training in accident prevention and maintenance procedures. All maintenance activities must be carried out only after safely stopping the machine and disconnecting the power supply to the engine.
- All maintenance activities must be performed only after safely stopping the machine and disconnecting the power supply to the engine. If the machinery is stopped during maintenance or repair operations, it must be protected against accidental restart. When replacing parts, spare parts must be ordered from ELGI's customer service and must meet ELGI's defined technical standards.
- The machinery's electrical equipment must be inspected periodically. Any faulty components must be promptly identified and replaced after a thorough assessment of their effectiveness and efficiency.
- Maintain the highest level of cleanliness during maintenance operations and avoid using flammable solvents.
- Before restarting the machinery after maintenance or overhaul, ensure that all guards and safety devices are restored and fully operational.
- Never use water to extinguish flames in case of fire (Figure 6.5-1).



Figure 6.5-1

**After completing maintenance operations, it is mandatory to restore all safety protections, especially around the moving parts of the cooling fan.**



## 6.6 Safety Precautions for the Toolbox

The compressor can be equipped with a toolbox to put tools and/or objects inside the machine.

- Before putting any tools and/or object inside the toolbox, make sure the machine is allowed to cool down for 10 minutes.
- **DO NOT** store containers with flammable or non-flammable liquid inside the toolbox.
- If you use the toolbox to store tools and other objects during the compressor handling and/or movement, make sure that the canopy is perfectly locked.

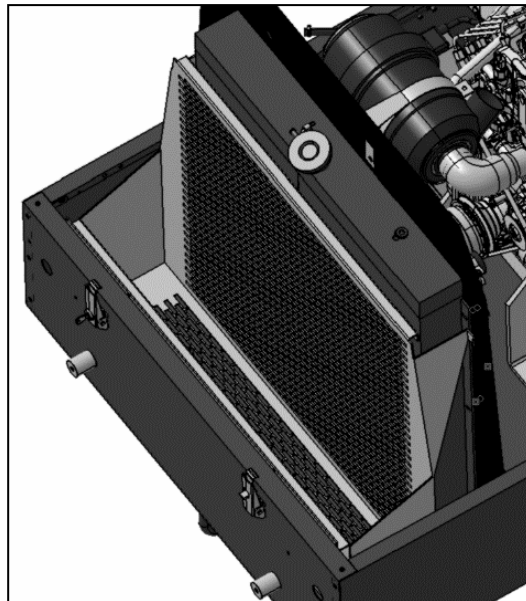

Picture 6.6-1 D185T4I-D185T4F Toolbox



**WARNING:** the toolbox must not have any tool and/or any other object inside before the compressor starting, to grant a perfect air flow allowing the radiator cooling.



The toolbox max loading capacity is 100 lbs (45Kg).



The toolbox has to be used only for the storage and transport of tools and/or objects. **DO NOT** use it while the machine is working for operator's safety reasons.



**WARNING:** The toolbox, while the machine is working, can reach temperatures that could cause skin burns. Make sure you have properly aired the toolbox before storing any object.



## 7 MACHINERY COMPONENTS

This unit D185T4F product range is a single-phase, silenced oil injection screw mobile motor compressor. The engine is an internal combustion engine fueled by diesel and is connected to the compressor via a flexible coupling. The coupling is designed to fail in the event that the engine or compressor locks up.

### 7.1 Chassis and Axle

The chassis is constructed from contoured, electrowelded sheet metal and features a load-bearing design. It undergoes a two-layer paint coating process to ensure corrosion resistance and rust protection.

The chassis houses the control panel, which is protected by a transparent polycarbonate lid. This panel allows users to monitor compressed air pressure and compressor oil temperature while also providing a visual check of the warning lights, each of which signals anomalies in the corresponding machine component.

The chassis is equipped with a drawbar that can accommodate either an eye hook or a ball coupling type hook. Its articulated elements enable proper attachment to various towing vehicles. The braking system consists of a parking brake and an inertia braking system, both of which operate on the wheel-carrier drums of the axle.

### 7.2 Body

The galvanized metal sheet bodywork undergoes a specialized painting process that provides a high-quality finish along with maximum resistance to impact and rust.

Strategically placed holes, complete with baffles, are integrated into the body structure to facilitate airflow. These allow cool air to be drawn in from one side for engine and compressor cooling, while heated air is expelled from the other side. The baffles are precisely designed in terms of size and shape to ensure optimal internal ventilation. It is essential to keep these openings unobstructed and in good condition.

All body components are treated with a specialized painting process to maintain superior finish quality and ensure maximum durability against impact and corrosion.

### 7.3 Engine

The unit is equipped with a diesel engine whose features are described in Section 2.

As related to the user's and maintenance instructions, refer to the manual provided by the manufacturer and enclosed to the documentation relevant to this machinery.

### 7.4 Compression Unit

This compression unit is fully manufactured in the plants and it consists of a centre body (cylinder) which host inside two asymmetric profile screw rotors: a 5-lobe male one and a 6-lobe female one.

The cylinder is closed at its end by two heads that contain the bearings which withstand the radial and axial loads generated by the compression of the air.

A set of channels machined in both the cylinder and the heads send oil to the different components. The lubricant that is thus distributed - besides lubricating the bearings - allows keeping a shroud of oil between the rotors and between the rotors themselves and the inner walls of the cylinder, thus fostering tightness to compression. Another significant function of the oil injected between the rotors is the absorption of the heat generated by the compression of the air.

The compressed air supplied by this compressor is pulse-free and the compression is generated axially.

An "adjuster" unit is mounted on the compressor to regulate the quantity of air to let in as a function of the air which is being consumed. Upstream this unit, a double-stage filter ensures the greatest purity of the inlet air.





## USER AND MAINTENANCE MANUAL

Date:	06/02/2025
Code	MAN D185T4F ENG
Revision	05

**Motor compressor : D185T4F**

### 7.5 Separator Tank

Consists of a pressurized container and is supplied with a conformity certificate ASME issued by the manufacturer. Identification and inspection details are engraved on a plate welded to the machine.

The lid is equipped with the following components:

A safety valve to prevent overpressure,

A thermal switch that activates if the internal temperature exceeds 100°C,

Valves that regulate the machine's maximum and minimum pressure.

### 7.6 Bell and Flexible Coupling

The engine and compressor are connected by a bell that ensures concentricity between the engine flywheel and the compressor shaft. A large block joint with interspersed rubber pieces transmits power smoothly and quietly without separation.

The engine-compressor assembly is secured to the frame using four flexible supports (silent-blocks) that fully absorb the vibrations generated. A fan, mounted on the engine shaft opposite the flywheel, generates significant air displacement to cool the machine's fluids and components.

### 7.7 Control Panel

The control panel, located on the right-hand side, was specifically designed to ensure that all controls are within easy reach of a single person. All necessary instruments for operating and monitoring the unit are integrated into the control panel.



**8 ELECTRICAL EQUIPMENT OF THE MACHINERY**

WARNING: any action on the electrical system must be performed by qualified personnel.

**8.1 Operator Panel Tools**

- 1) Pressure gauge;
- 2) Control board;
- 3) ON/OFF switch;
- 4) Up/down arrow keys;
- 5) Pressure switch;

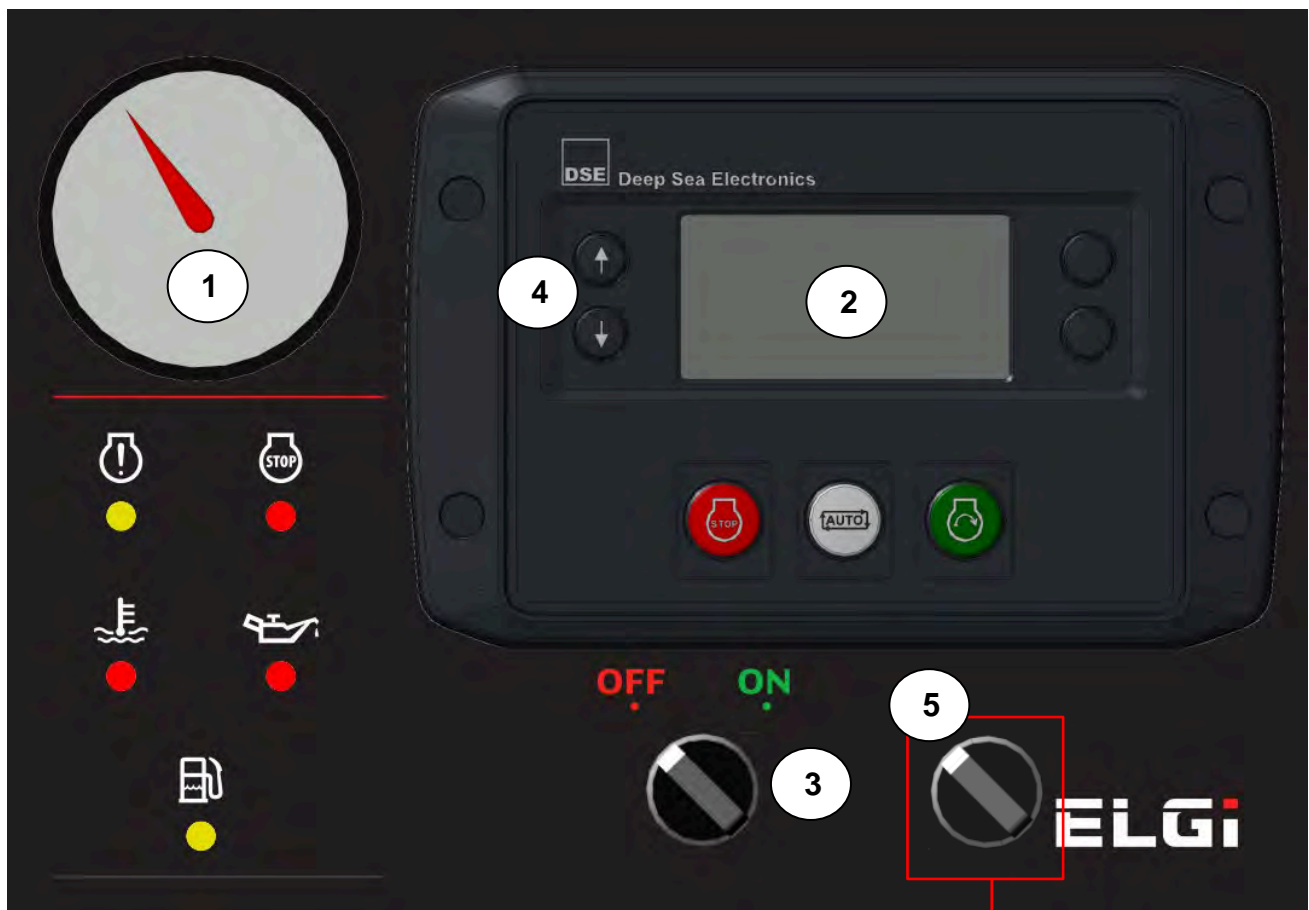







Figure 8.1-1 Instrument panel and control devices

**DUAL PRESSURE Version**



**8.2 Operator Panel Pilot Lamps**

PILOT LAMP	DEFINITION	FUNCTION	OPERATION TO BE PERFORMED
	HIGH TEMPERATURE LAMP	This pilot lamp highlights that the radiator cooling liquid have reached an excessive temperature	Immediately switch off the machine and verify the following cases 1) check the liquid level in the radiator and clean it; 2) the cooling liquid pump does not operate as appropriate (contact ELGI customer service); 3) the liquid valve does not close or open at the right moment (replace); 4) if the cooling liquid is leaking, contact ELGI customer service; 5) the radiator is obstructed (contact ELGI assistance).
	ENGINE OIL PRESSURE LAMP	This pilot lamp highlights the insufficient pressure of the engine oil. The lamp is off when the engine oil is in pressure Pilot lamp lit: engine oil not in pressure.	The oil pilot lamp highlights the insufficient pressure of the oil. Such insufficient pressure may be caused by: 1) Low engine oil level, 2) Failure of the delivery pump, 3) Oil not reaching the delivery pump.
	STOP ENGINE	This warning light lit when the engine control unit detects a serious malfunction.	<b>STOP</b> the engine immediately and contact ELGI assistance service.
	WATER IN THE FUEL	The fuel warning light lit when the engine sensor detects the presence of water in the fuel system.	<b>STOP</b> the engine immediately, empty the fuel tank and fuel system. Replace with new fuel.
	CHECK ENGINE	This light signals lit when the engine sensor detects a problem (a broken sensor, etc.)	The problem detected by the engine is of medium entity and allows the compressor to continue to be used; to identify the status of the problem, check the electronic control board.

### 8.3 Electronic Control Board

Switching on the panel with the ON / OFF switch (Figure 8.1 1 - N.3) turns on the Deep Sea electronic control board;

Below are the screens of the board which, in rotation of a.c. 7 seconds, will be shown on the display and related information.

You can manually scroll through the screens using the arrow keys **↑↓** (No.4 - Figure 8.1 1) on the board.

#### Status

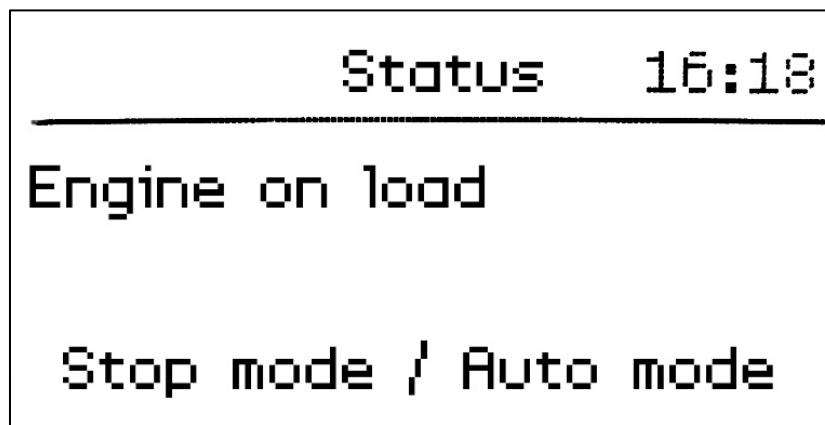

- Engine running: The engine is running and ready to work.
- Auto Mode: Displayed when the engine is under load.
- Stop mode: is displayed when the control board is turned on and the engine has not been started yet.

#### Engine speed RPM

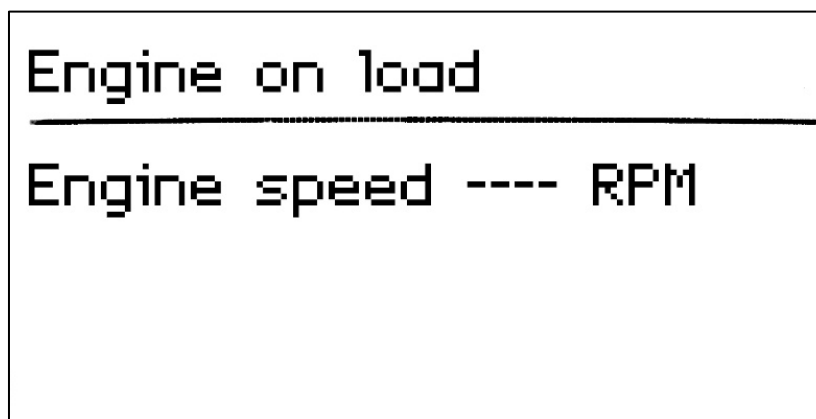

- Motor speed: displays the rev / min (rpm) of the motor.



**Engine information**

$\%$	---- bar
Eng. Percen	Engine oil pres
---- rpm	---- C°
Engine speed	Engine cool

- Percentage of engine load
- Engine oil pressure
- Motor speed (rpm)
- Coolant temperature

**Air pressure information**

Ø	---- V
Start(s)	Battery
---- RPM	---- bar
Engine speed	Air pressure

- Start (s): number of engine starts
- Battery: Volt indication of the battery
- Motor speed (rpm)
- Air pressure: air pressure on service valve / s



### Engine running time

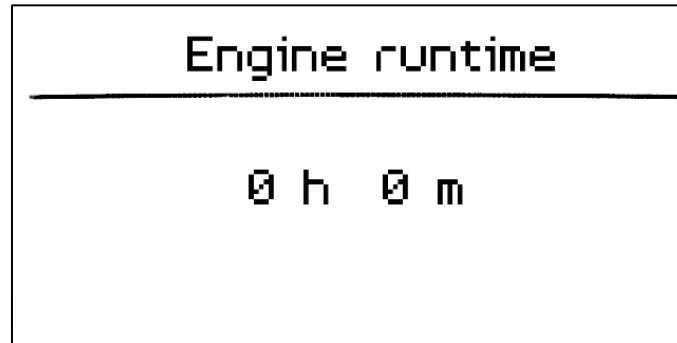

- Engine runtime: displays the hours and minutes of engine use.

### Maintenance and replacement of air filter and engine oil filter

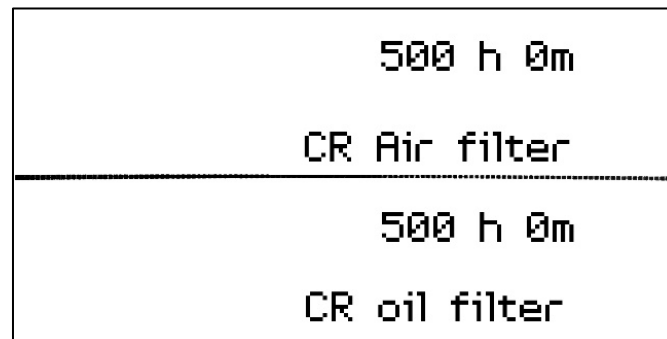

- Substitute air filter: Indicates how much time is left until the recommended replacement of the engine air filter.
- Substitute oil filter: Indicates how much time is left until the recommended replacement of the engine oil filter.

**Once the filters have been replaced, to reset the counter proceed as follows:**



Figure 8.3-1 STOP button on the electronic board deepsea

**Hold the STOP button (Figure 8.3-1 ) for 5 seconds when the alarm is displayed and the module is configured for maintenace reset by front panel.**

Fuel level

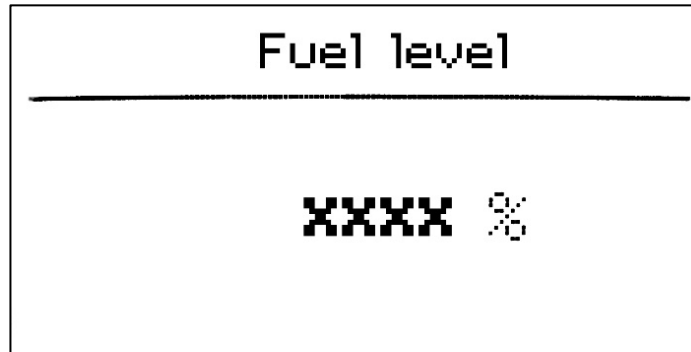

- Fuel level: indicates the percentage of fuel inside the tank.

STATUS



**ATTENTION:** The display of icons on the warning screen indicates an engine problem / warning; below you will find what they indicate.

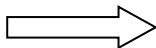

**Problem / malfunction:** STOP the engine immediately and call assistance

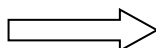

**Fuel level below 10%:** the engine will automatically stop afterwards c.a. 10min; should you continue to operate it will be possible to restart the machine, following the second shutdown, the tank will need to be refilled.

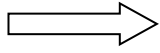

**Activation of the Grid heater (Optional)**

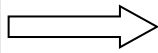

**Available power:** indicates that the engine is not delivering all available power  
(problem or malfunction)



**ATTENTION:** In order to extend the “key on” time to 15 minutes it is necessary to press the  key 5 times;



to verify the correct activation of the extension of the 15 min “key on” period, the lights on the control board will flash as in the image below.



#### 8.4 Reading Error Messages and Alarms on the DEEP SEA Control Board

The display of errors and alarms (engine side and compressor side) can be done both with the engine running and the engine off.

##### ENGINE OFF

1. To enter the menu related to error codes and alarms it is necessary to power the engine electronic control unit;
2. With the ignition on (ON selector) press the hare button 6 times until the indicator lights light up



Lights ON indicate the engine control unit is powered.



**ATTENTION:** If after pressing the hare button 6 times, the indicator lights do not light, press the green engine start button;

3. To scroll through the main menu, you must press the "up" or "down" arrow and hold it for 2 seconds to display the menu pages, to change the page, then press and hold the arrow until the page is changed.



4. If the arrow is pressed quickly scroll through the main menu pages

## ENGINE RUNNING

When the engine is running, the motor circuit board is already powered from point 3

### 5. ERROR DISPLAY ENGINE ELECTRONIC CARD (ACTIVE DTC)

- Scroll through the pages as described in point 3 to the page "DTC Active"
- Within this page are displayed active errors (live) in the electronic engine board.
- These errors have a code + a small description



**ATTENTION:** It is important to enter this page to indicate to the assistance or to the motorist what are the active errors in the engine control unit



### 6. COMPRESSOR ALARMS + ENGINE ALARMS (ALARMS)

- Scroll through the pages as described in point 3 to the page "ALARMS"
- Within this page you will see active alarms (live) from the compressor side and general descriptions regarding engine alarms.



## 7. VIEWING LOG OF EVENTS

- Scroll through the pages as described in point 3 to the "EVENT LOG" page
- This page displays all the events that occurred during the use of the compressor (ignition, fuel reserve, engine errors, compressor errors).
- The log is the history of the warnings that appeared during the use of the compressor



Date:	06/02/2025
Code	MAN D185T4F ENG
Revision	05

## Motor compressor : D185T4F

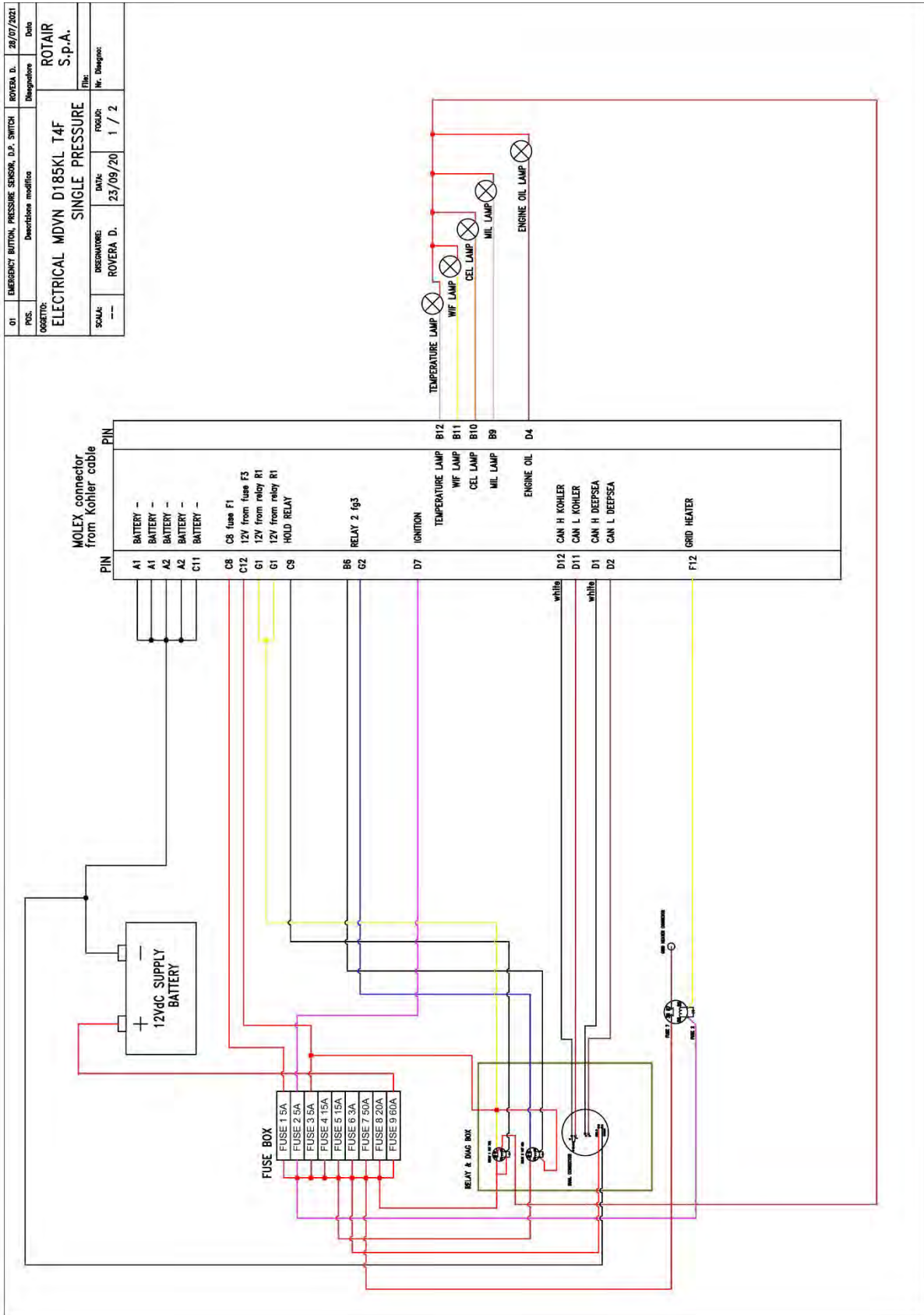

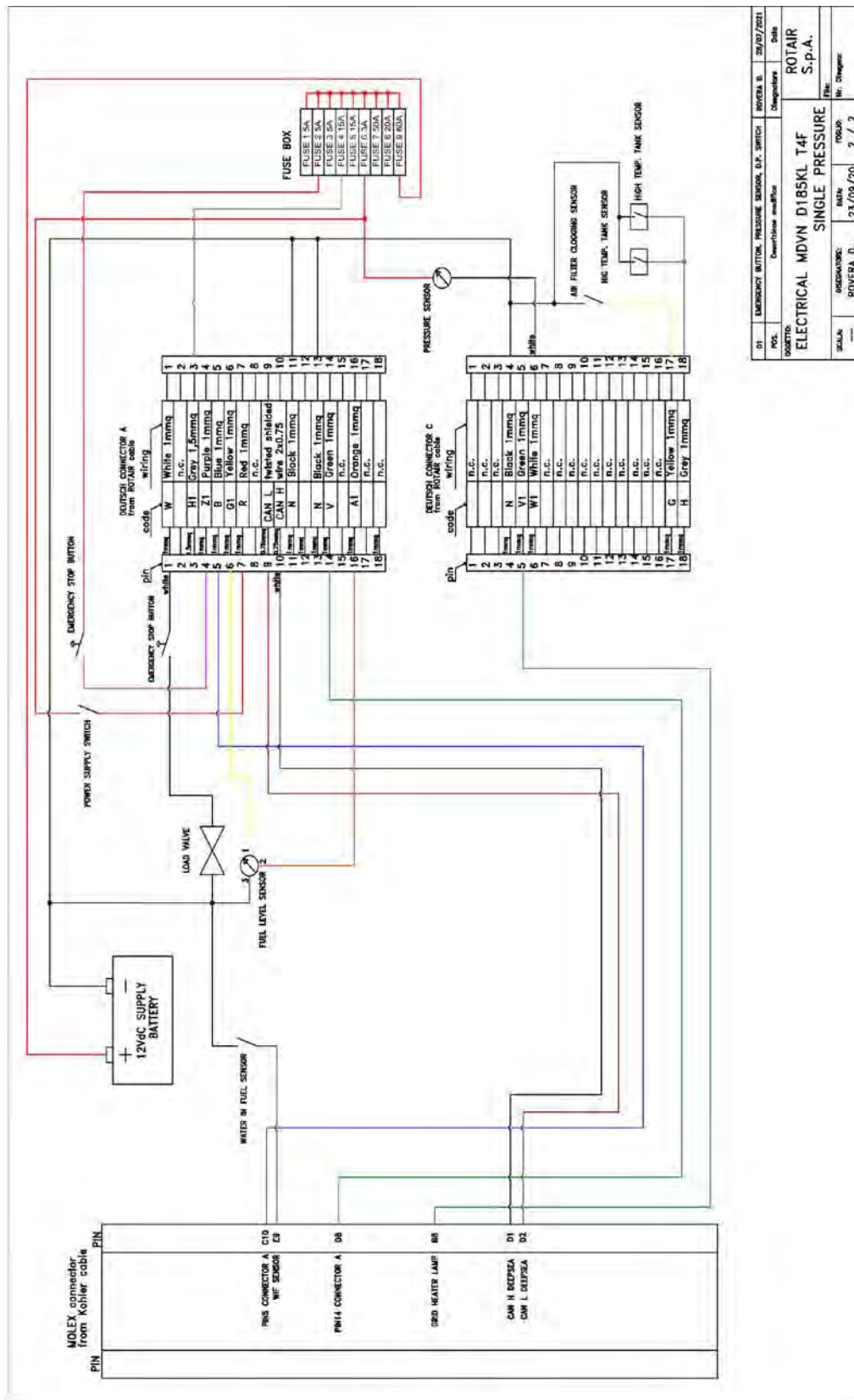
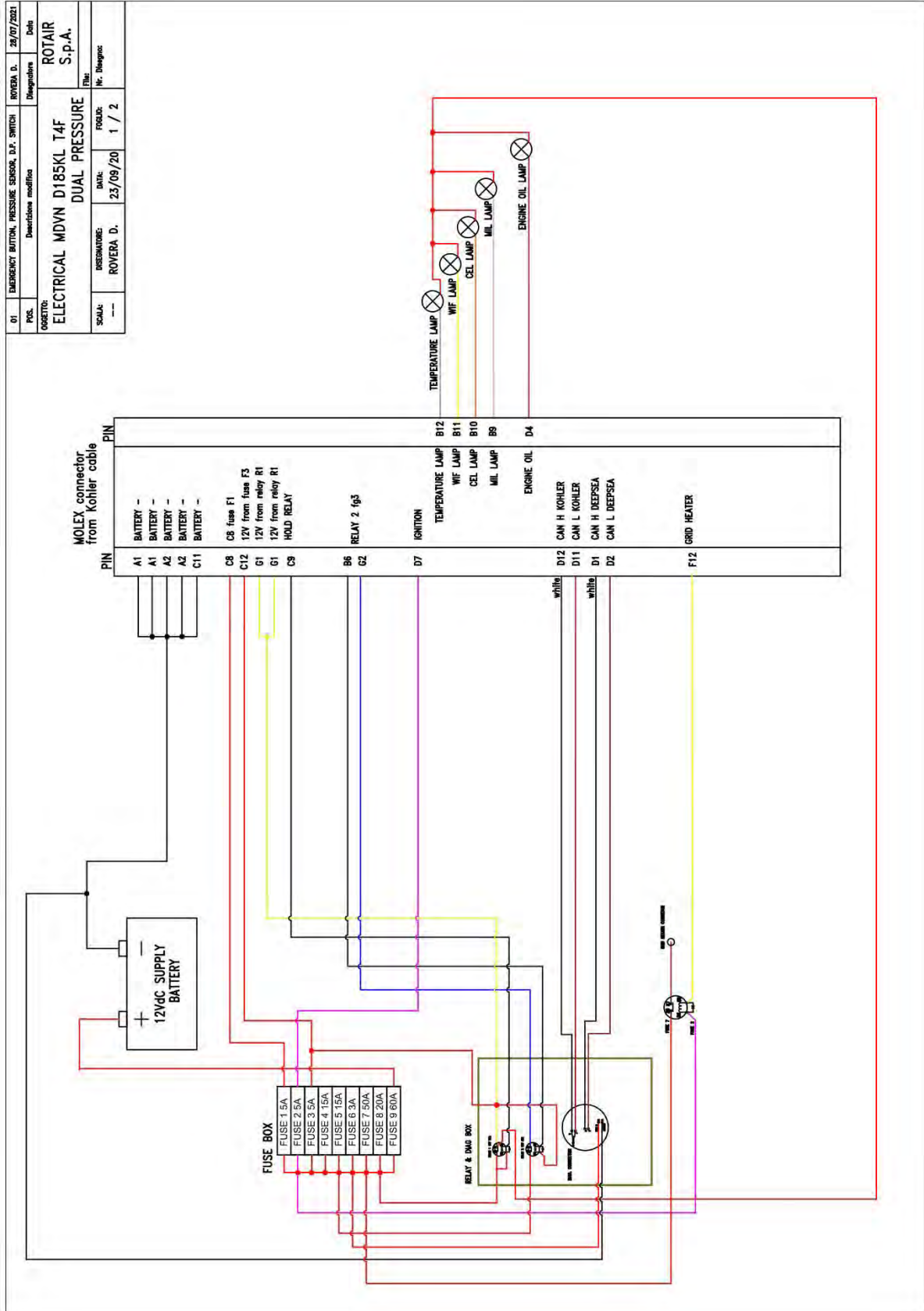

**Figure 8.2-2 Diagram machine's electrical system D185T4F**



Date:	06/02/2025
Code	MAN D185T4F ENG
Revision	05

## Motor compressor : D185T4F



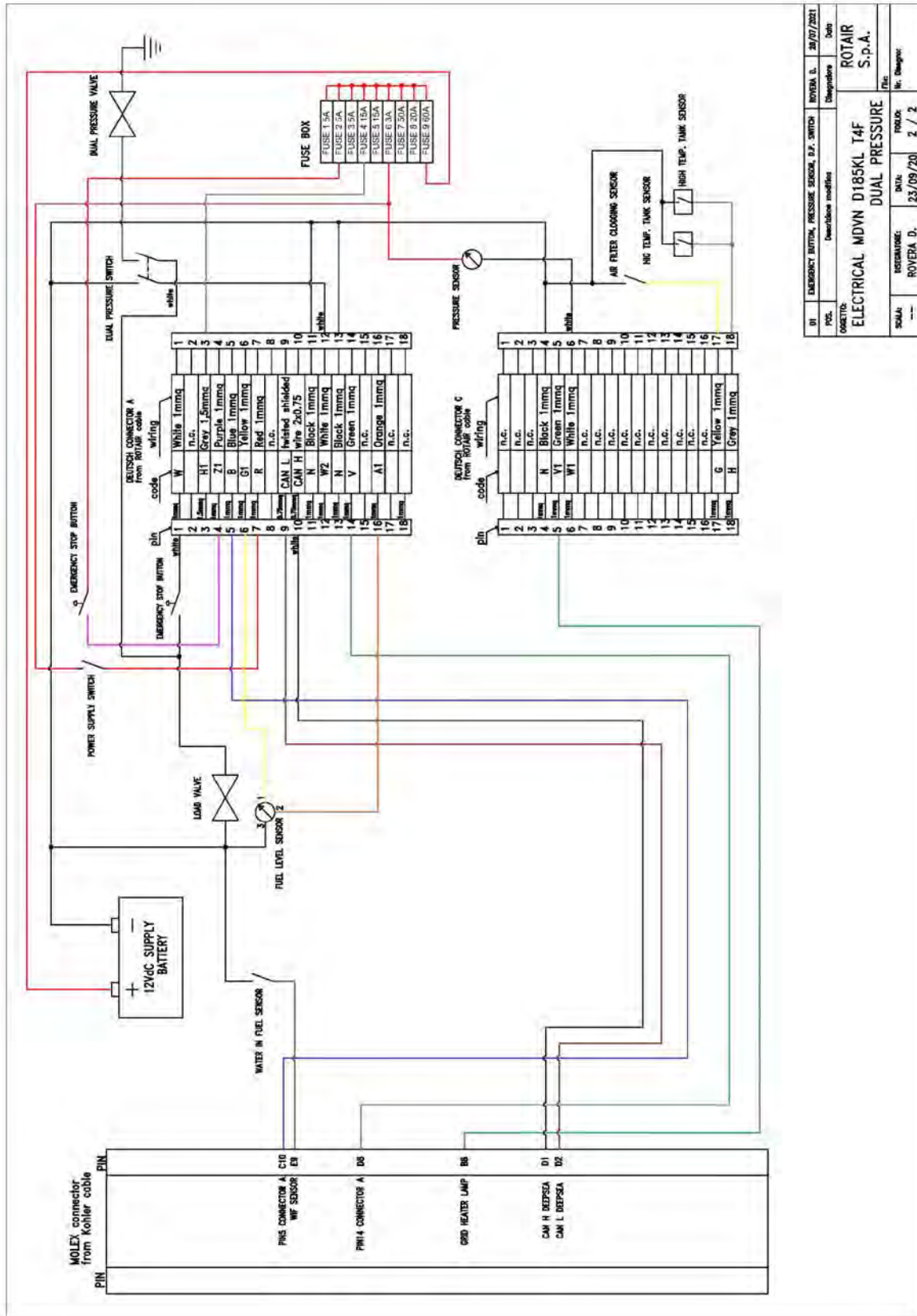

DI	EMERGENCY BUTTON, PRESSURE SENSOR, P.F. SWITCH	ROVERA D.	28/07/2021
POC	Description modification	Disegnatore	Data
OGGETTO:	ELECTRICAL MDVN D185KL T4F DUAL PRESSURE		
SOLAI:	ROVERA D.	DATA:	25/09/20
		FOLIO:	2 / 2
		File:	
		Nr. Disegni:	

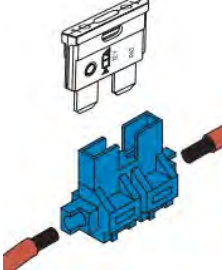

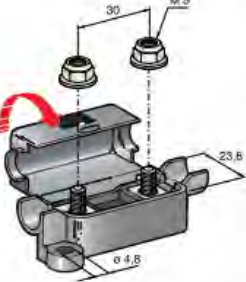

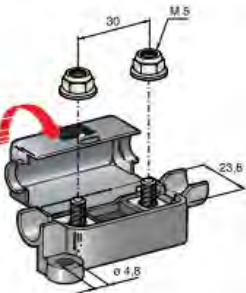

**Figure 8.2-3 Diagram machine's electrical system D185T4F (Dual Pressure)**



**8.3 Fuses**

The fuse is an electrical device which can protect a circuit or a device from over current.

The fuse consists of a cartridge provided by a thin lead wire through which the rated current of the circuit/element transits; this wire is the actual fuse, with a precise Amp load. In case of overcurrent, the filament melts and causes the circuit to open.

Fuse holder	Fuse	Description	Ampere
		Secondary fuse: device to protect against overcurrent which might damage the fuel solenoid	16 A
		Operator Panel Fuse: protection device against overcurrent that may damage the operation panel	40 A
		Protection device against overcurrent that could damage the engine glow plugs during warm.	40 A



**WARNING:** When replacing the fuses, we recommend always utilizing the same type as indicated in this table and to follow the procedure reported in section 13.4.3 of the manual.

#### 8.4 Lights (Road-Certified Version)



The electrical system is completed by the light wiring (Figure 8.4-3). This system is directly connected to the towing machine through an extension supplied with the motor compressor.

##### Rear lights:

- 1) Turn light
- 2) Position and stop light (stop detected by light intensity)

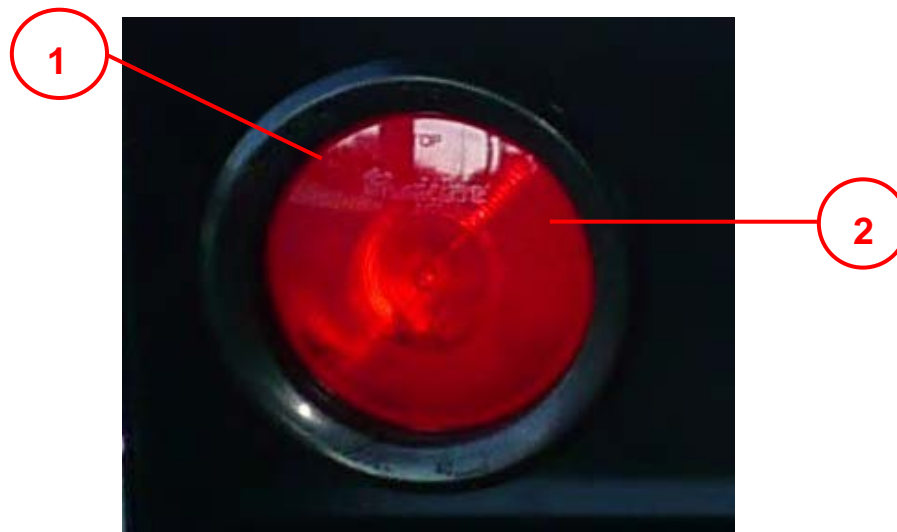
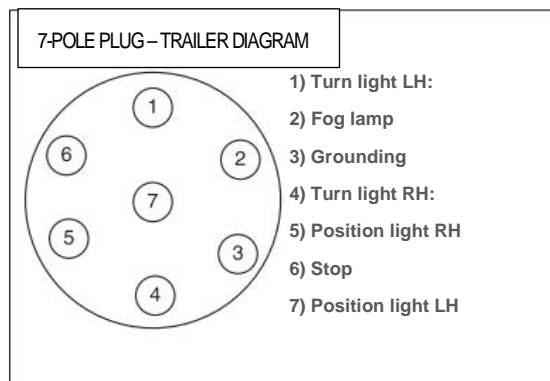

Figure 8.4-1 Rear light



**WARNING:** To replace the lamps, refer to the Maintenance chapter.

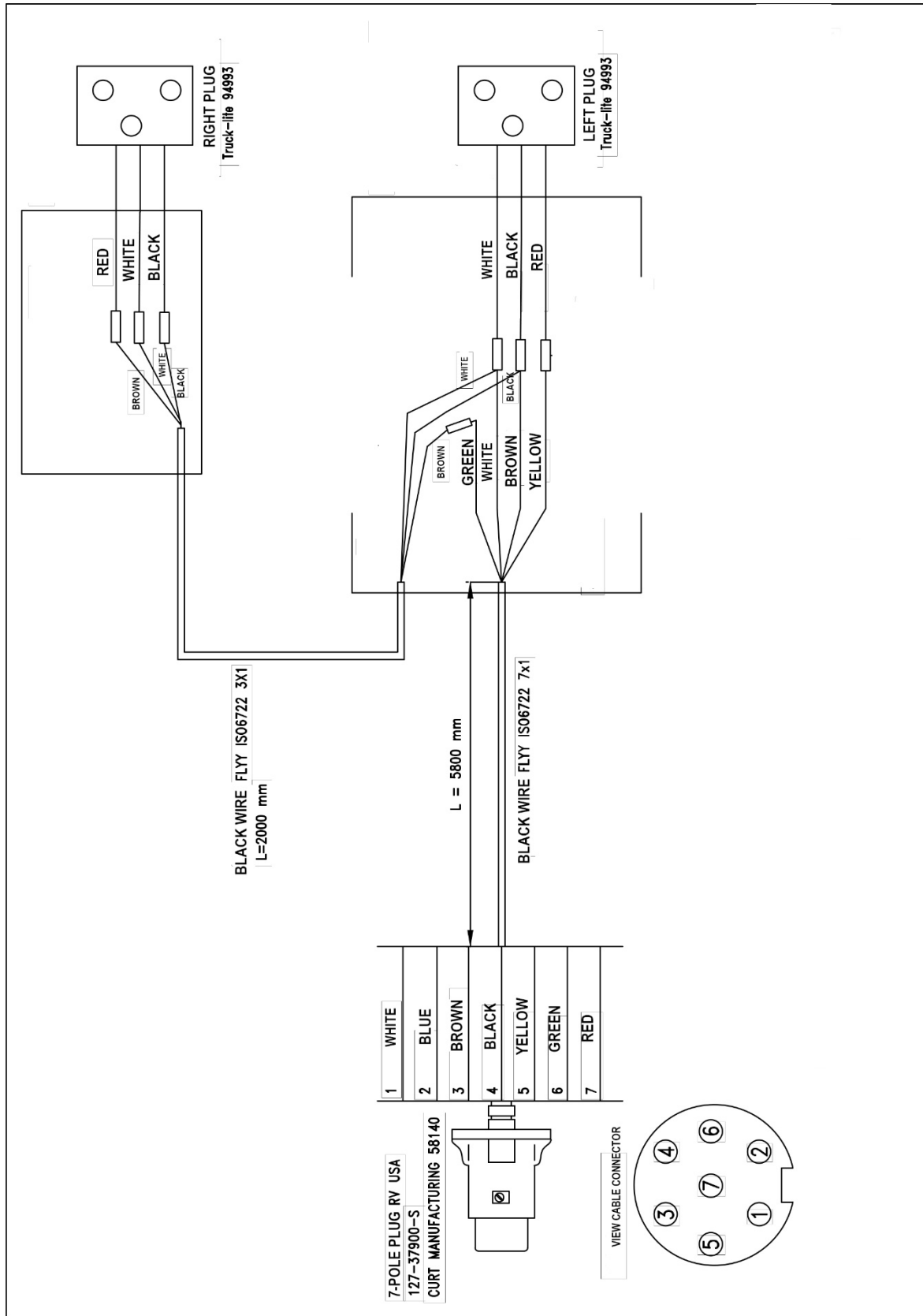

Figure 8.4-3 Light wiring harness



**9 HYDRAULIC AND PNEUMATIC SYSTEMS**

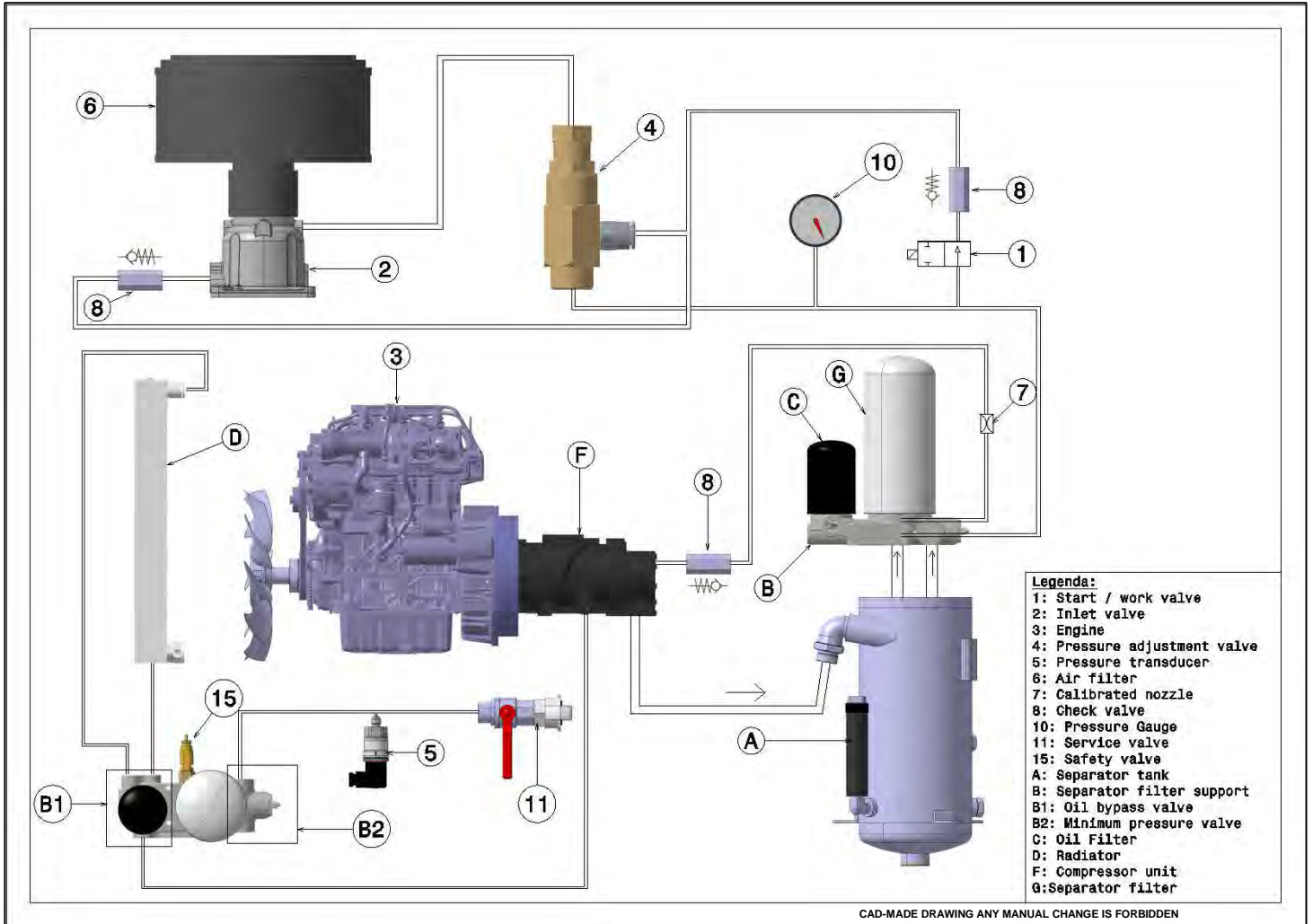

Figure 9.1-1 D185T4F (STANDARD) Hydraulic and pneumatic systems

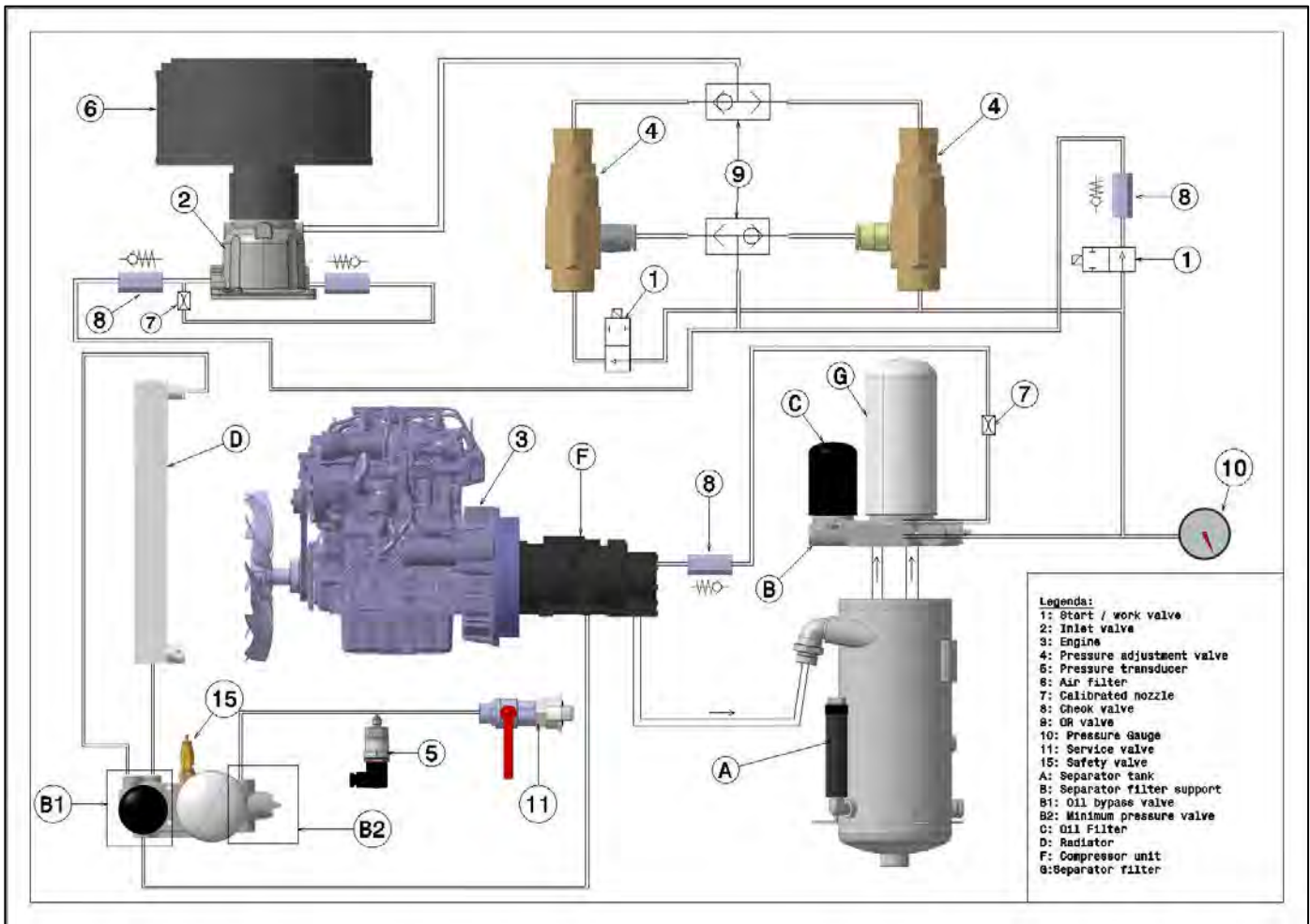

Figure 9.1-1 D185T4F (DUAL PRESSURE) Hydraulic and pneumatic systems

## 9.1 Hydraulic Lubrication System

The compressor lubrication system (Figure 9-1) consists of:

- Separator tank (A);
- Separator filter (G);
- Minimum pressure valve (B2)
- Oil filter (C);
- Cooling radiator (D);

As you may notice, the lower portion of the separator tank (A) is used as oil tank while the minimum pressure valve located in the upper part (B) operates as a support of the separator filter (G).

When starting up the machinery, the oil under pressure located in the tank starts flowing through the duct into the oil filter (C), and from there to the cooling radiator (D).

The cooled filtered oil then reaches the compressor (F) and - by means of appropriate inner piping - is distributed to the different components (rotors, bearings, etc.), which are thus lubricated and cooled.

From the compressor (F), the oil -mixed to the compressed air in input from the check valve (8), is sent to the tank (A), where - through a forced centrifugal circuit - the compressed air is submitted to a first separation from

	<b>USER AND MAINTENANCE MANUAL</b>	Date:	06/02/2025
		Code	MAN D185T4F ENG
<b>Motor compressor : D185T4F</b>		Revision	05

the oil.

The resulting compressed air leaves the separator tank through the separator filter (G), which will provide to a second and last separation of the air from the remaining oil.

Even though the separating filter (G) separates the air from the oil, it is worth pointing out that a limited quantity of the latter manages to penetrate inside the filter and deposits on the lower portion of the filter itself.

The oil is sucked into the piping where a calibrated orifice (7) and a check-valve (8) will route it to the compressor (F).

The check valve (8) shall prevent the oil from returning into the separator filter (G) when the machinery is stopped.

Attention! The oil filter (C) is provided with a “by-pass” valve which allows the oil to circulate also in case it is clogged. In such case, the oil shall circulate regularly without being filtered.



**WARNING: The filter needs therefore to be replaced at regular intervals, as specified in the maintenance program.**

## 9.2 Pneumatic System

The pneumatic system (Figure 8.4-1) includes:

- Start/work valve (1).
- Air filter(6);
- Inlet valve (2);
- Compressor (F);
- Separator tank (A);
- Separator filter (G);
- Minimum pressure valve (B2)
- Service valve (11);
- Max. pressure valve (4);

The incoming air passes through the air filter (6) before reaching the suction regulator (2) and then enters the compressor (F). The compressor pressurizes the air and conveys it, along with the injected oil, into the oil separator tank (A). In this tank, the initial separation of oil from air occurs through centrifugal force, followed by further filtration using the oil separator filter (G).

Once the air is purified of oil, it flows to the minimum pressure valve (B2), which opens only when the tank pressure reaches the predetermined level.

It is essential to avoid using tools with excessive air consumption, as they may cause the tank pressure to drop below 5–5.1 bar (72.5 PSI). Prolonged operation under 5 bar can lead to inadequate oil separation, resulting in abnormal lubricant consumption.



**WARNING: pressure vessel**



	<b>USER AND MAINTENANCE MANUAL</b>	Date:	06/02/2025
		Code	MAN D185T4F ENG
<b>Motor compressor : D185T4F</b>		Revision	05

### 9.2.1 AUTOMATIC ENGINE RPM ADJUSTMENT

The system controls the Diesel engine rpm as a function of the compressed air retrieved and includes:

- Max. pressure valve (4);
  - Inlet valve (2);
  - Pressure transducer (5)
- With the engine running and the service valve (11) fully open, the engine rpm are at the max value and the inlet valve (2) is fully open.
  - Partially close the service valve (11) to simulate a reduction in the air consumption with subsequent increase of the pressure in the tank (A).
  - When the service valve (11) is progressively closed, the pressure reaches the established adjustment value and the max. pressure valve (4) ones letting the compressed air flow out and act - at the same time - on the pressure transducer (5) and under the inlet valve (2).
  - Under the action of such pressure the pressure transducer (5) proportionally decelerates the engine.
  - At the same time, the inlet valve (2) proportionally closes as well, thus reducing the passage of the air which is being pulled in. Consequently, with the service valve (11) closed and - subsequently - without any air retrieval, the engine shall stabilize at the minimum rpm it was adjusted for, while the suction regulator (2) of the adjuster shall move to an almost total closing position.
  - At this stage of the cycle, the inlet air is minimum and is used to compensate for any leakages and internal leakages of the circuit.
  - The pressure gauge on the control panel shall display the value of the max. final pressure.
  - When air is resumed to be retrieved, the max. Pressure valve (4) shall start closing again and shall be totally closed once the pressure valve lowers by approx. 1 bar versus the value of the max. final pressure.
  - At this stage, the compressor delivers the max. rate at the service pressure, since the internal pressure in the pressure transducer (5) accelerate the engine up to the max. Speed, and the suction adjustment valves is the full opening position.
  - If tools of greater consumption that the rated capacity of the compressor are used, the pressure gauge shall display a lowering of the pressure which - in any case - must never be lower than 5 bar.
  - **Avoid sudden openings of the service valves: they generate strong stress to the separator filter, with subsequent severe damage to the filter itself.**



	<b>USER AND MAINTENANCE MANUAL</b>	Date:	06/02/2025
		Code	MAN D185T4F ENG
<b>Motor compressor : D185T4F</b>		Revision	05

## 10 GUIDELINES FOR THE PROPER USE OF THE MOTOR COMPRESSOR

Refer to the user and maintenance manual before starting the machinery.

### 10.1 Pre-Start Checklist

Before starting-up the machinery, strictly follow the instructions here in under:

1. Level the planarity of the machine by acting on the support foot or on the wheel: no incline greater than 15° is allowed;
2. make sure that the electric wires are connected to the battery terminals; if the connection is to be performed, use the greater care so that the cable coming from the starter motor is connected to the positive pole (+) of the battery and the earthing one is connected to the negative pole (-) of the battery.

3. Check the fuel level in the tank\*.



**DIESEL**

**\* Only use Diesel fuel for topping up.**



Figure 10.1-1 Fuel tank for Diesel engine

4. Check the level of the engine oil: as related to the types of lubricant and relevant quantities, comply with the instructions contained in the engine manufacturer's users and maintenance manual enclosed to the machinery documentation.
5. Check the oil level in the compressor: this operation must be performed not before than 15 minutes after operation, this to allow the lubricant in circulation to flow completely into the separator tank.
  - a) Before unscrewing the oil indicator dipstick (A) where the level gauge is attached, make sure that there is no longer any pressure in the system. (The pressure gauge shall indicate 0 bar).
  - b) Take off the dipstick (A) and clean the level gauge.
  - c) Thoroughly screw back the oil indicator dipstick (A) and then take it off again to verify that the lubricant level is included between the two marks (min. and max. level) engraved on the gauge.
  - d) Top up if required: the level must never exceed the max. mark.



	<b>USER AND MAINTENANCE MANUAL</b>	Date:	06/02/2025
		Code	MAN D185T4F ENG
<b>Motor compressor : D185T4F</b>		Revision	05

e) Exclusively utilize the types of oil recommended in this user's and maintenance manual.

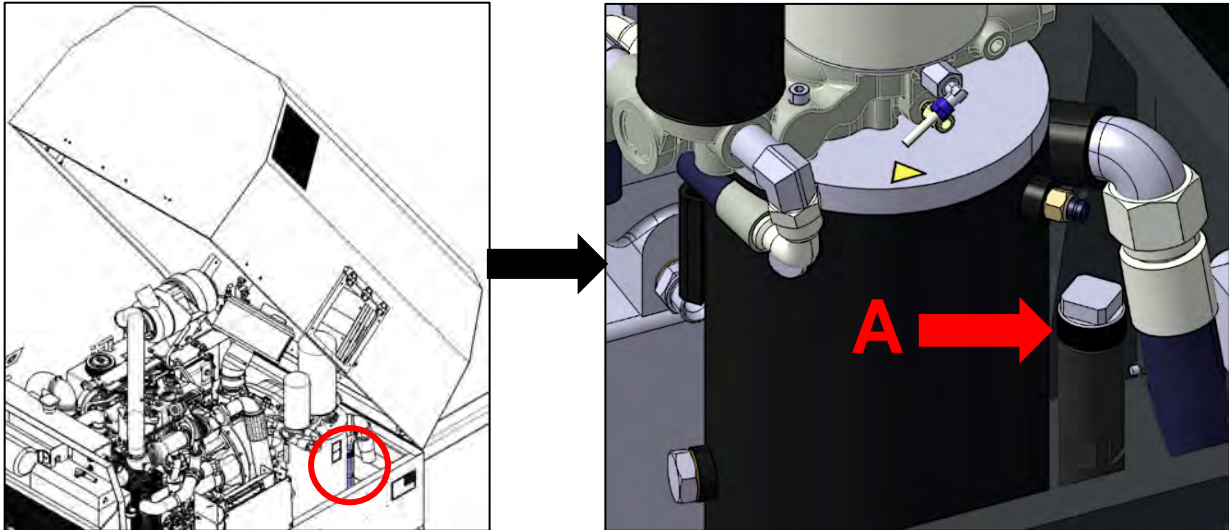

Figure 10.1-2 Checking the oil level in the compressor

6 If the motor compressor is equipped with a liquid-cooling diesel engine, check the level of the antifreeze contained in the radiator (Figure 10.1-3).



Figure 10.1-3 Checking the radiator cooling liquid

Recommended cooling liquid: PEAK EUROPEAN BLUE



**WARNING:** *the radiator cap (Figure 10.1-3) must never be removed when the engine is hot: this would cause a sudden outflow of liquid which might cause severe scalding. Topping up - if required - must be made by means of a blend of water and anti-freeze liquid, in the percentage indicated in chapter 13.4.6 .*



	<b>USER AND MAINTENANCE MANUAL</b>	Date:	06/02/2025
		Code	MAN D185T4F ENG
<b>Motor compressor : D185T4F</b>		Revision	05

## 10.2 Start-Up Procedure

Operations to be carried out for correct starting of the motor compressor:



Figure 10.2-1 Electronic control board

- 1) Completely close the service valves
  - 2) Place the ON / OFF switch (detail 3 Figure 8.1 1) in the "ON" position, the panel is powered
  - 3) Press the green button of the start button (A), the engine starts.
  - 4) Once the engine is started, it will run at minimum speed for about 45 seconds; the pressure gauge will indicate a pressure level between 2-3 bar.
- If one or more of the lights on the control device are still on after 5-6 seconds, stop the machine immediately to find the cause.
- After 45 seconds the motorized compressor will automatically enter work mode: the motor will accelerate, the suction valve will open and the pressure gauge will reach the maximum calibration values.
- 5) Then connect the compressed air delivery pipes to the relative tools.
  - 6) Gradually open the service valves (Figure 10.2-1 - B).
  - 5) Then connect the compressed air delivery pipes to the relative tools.



**WARNING:** *It is forbidden to open the machinery with the engine hood open.*



	<b>USER AND MAINTENANCE MANUAL</b>	Date:	06/02/2025
		Code	MAN D185T4F ENG
<b>Motor compressor : D185T4F</b>		Revision	05

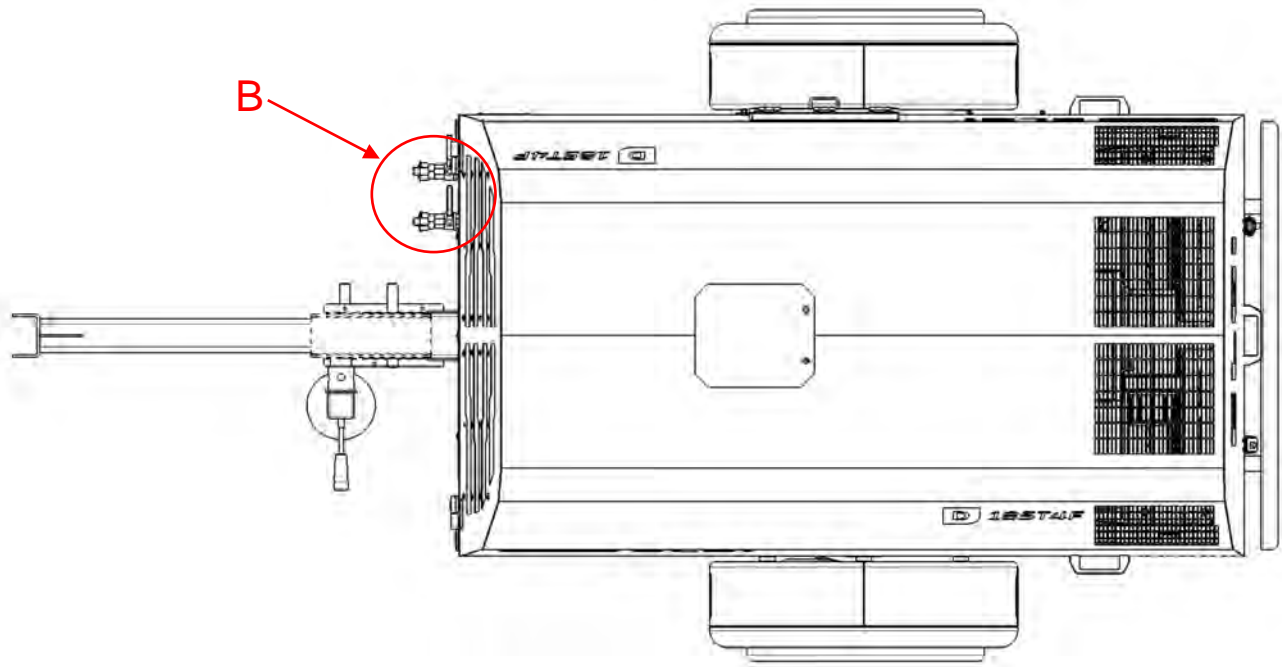

Figure 10.2-1 Location of the service valves (top view)



**WARNING:** *Do not inhale the compressed air discharged from this unit's outlets.*

### 10.3 During Operation



The machine must always operate with the hood down and closed.

During the work cycle it is necessary to verify that the intake openings are free of foreign bodies such as pieces of paper, plastic, etc ... as these materials can create obstructions to the ventilation system.



**WARNING:** *in the vicinity of the exhaust pipe are very hot exhaust gases and harmful. Avoid these*



	<b>USER AND MAINTENANCE MANUAL</b>	Date:	06/02/2025
		Code	MAN D185T4F ENG
<b>Motor compressor : D185T4F</b>		Revision	05

areas as necessary while the machine is running.

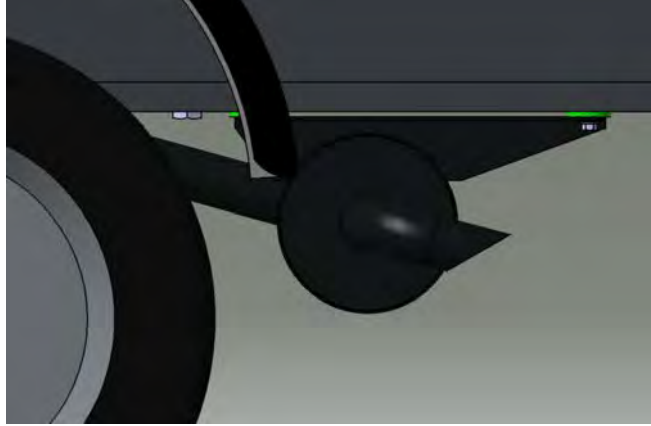

Figure 10.3-1 Exhaust pipe

#### 10.4 Stopping the Machine

- 1) Completely close the service valves (Letter B - Figure 10.2-1).
- 2) Press the red stop button (C) the compressor will act to depressurize the machine until the pressure of the gauge reaches a value of 3.5 bar before stopping.
- 3) Place the ON / OFF switch (detail 3 Figure 8.1-1) in the OFF position;

#### 10.5 Post-Stop Procedures

- 1) If the machine has operated in a dusty environment, clean or replace the air filter and check the cleanliness of the cooling radiator. If clogged, follow the maintenance instructions provided in the relevant section.
- 2) Check that during the working phase there are no losses of fuel or lubricating oil inside the machine
- 3) Where possible place the machine away from the elements.

## 11 MACHINE MONITORING AND TESTING

### 11.1 Engine Speed Monitoring and Testing



**ALL TESTING AND CALIBRATION SYSTEMS MINIMUM AND MAXIMUM, MUST BE DONE BY A PROFESSIONAL, INFORMED, FORMAT AND TRAINED, EQUIPPED WITH A SPECIAL EQUIPMENT TACHYMERIC A STRIKER REFLECTIVE AND EQUIPPED WITH HEADPHONES NOISE.**



*For all calibrations and adjustments we highlight the following residual risks*



Moving parts present. Be aware of mechanical hazards.



The presence of hot surfaces at high temperatures. Pay attention to the risk burn.



**11.1.1 MAXIMUM ENGINE SPEED CONTROL SYSTEM**

The calibration of the maximum speed is set by the manufacturer. It should not be changed for any reason. Any tampering or variation of the maximum speed of rotation of the motor will cause an immediate voiding of the warranty.

**11.2 Air Pressure Monitoring and Control for the Compressor**

Figure 11.2-1 Adjusting maximum pressure

The maximum pneumatic pressure is calibrated during the testing phase of the machine.

If the value of the maximum pressure pneumatic, indicated by the pressure gauge on the control panel, diverged over a  $\pm 5\%$  from the value specified in Paragraph 2 of this manual, proceed as follows:

1. Start the machine as described in section 10.2 "Start",
2. Wait for the compressor reaches the maximum pressure and the engine stating the values of idle speed;
3. Close all service valves (Letter A in Figure 10.2-1);
4. Open the canopy with the compressor in motion;
5. Unscrew with wrench 22 mm wrench the nut (Letter A in Figure 11.2-1);
6. If you want to increase the maximum pressure must tighten with 19 mm wrench, nut (Letter B in Figure 11.2-1);
7. If you want to reduce the pressure unscrew, with a 19 mm wrench, nut (Letter B in Figure 11.2-1);
8. Once the valve is adjusted, tighten the lock nut with a 22 mm wrench (Letter A in Figure 11.2-1);
9. Slightly open ball valve for 3-4 seconds and close off. Repeat as necessary to seat the valve.
10. Read on the pressure gauge located in the control panel, confirm the value of the maximum pressure reached;
11. Compare the measured value with that reported in Paragraph 2, repeat the steps up to the alignment of the two values;

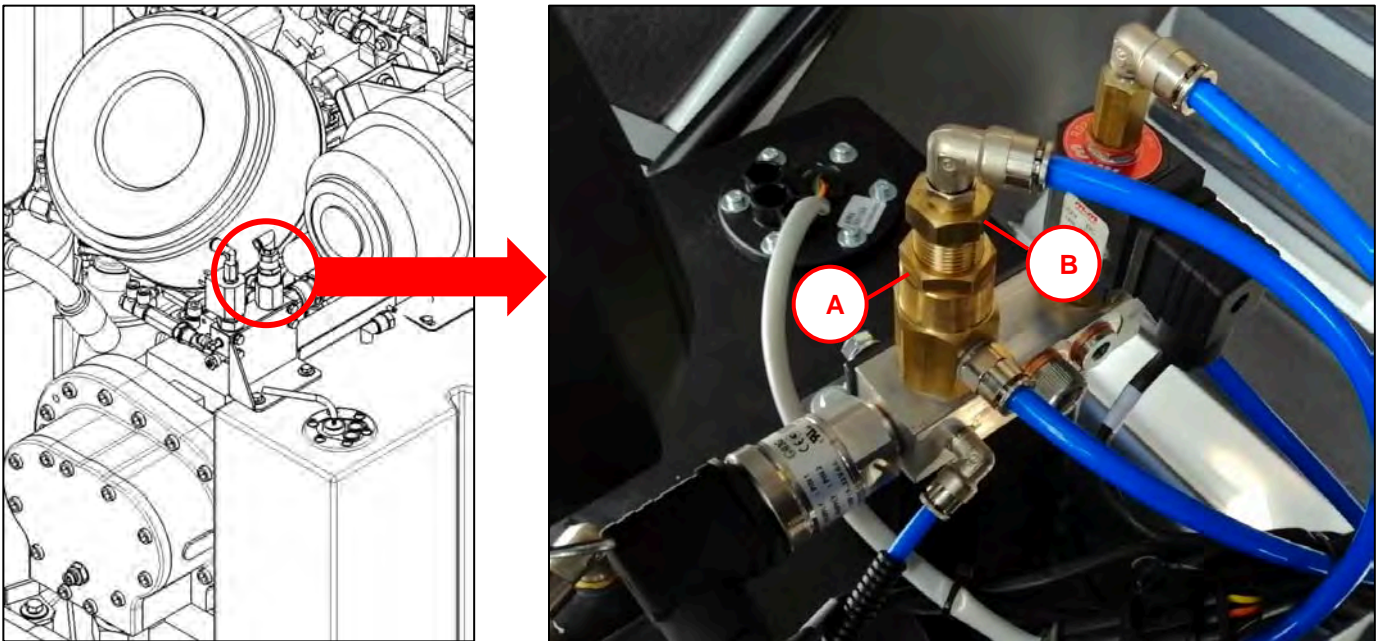
<b>ELGI</b> <sup>TM</sup>	<b>USER AND MAINTENANCE MANUAL</b>	Date:	06/02/2025
		Code	MAN D185T4F ENG
<b>Motor compressor : D185T4F</b>		Revision	05

12. Close the canopy.



**WARNING:** Notice: if the gauge is indicating a inconsistent pressure value, you will have to replace it. So, before making any calibration valve high or low pressure, make sure that the gauge is efficient and reliable.

### 11.3 Minimum Air Pressure Monitoring and Control for the Compressor

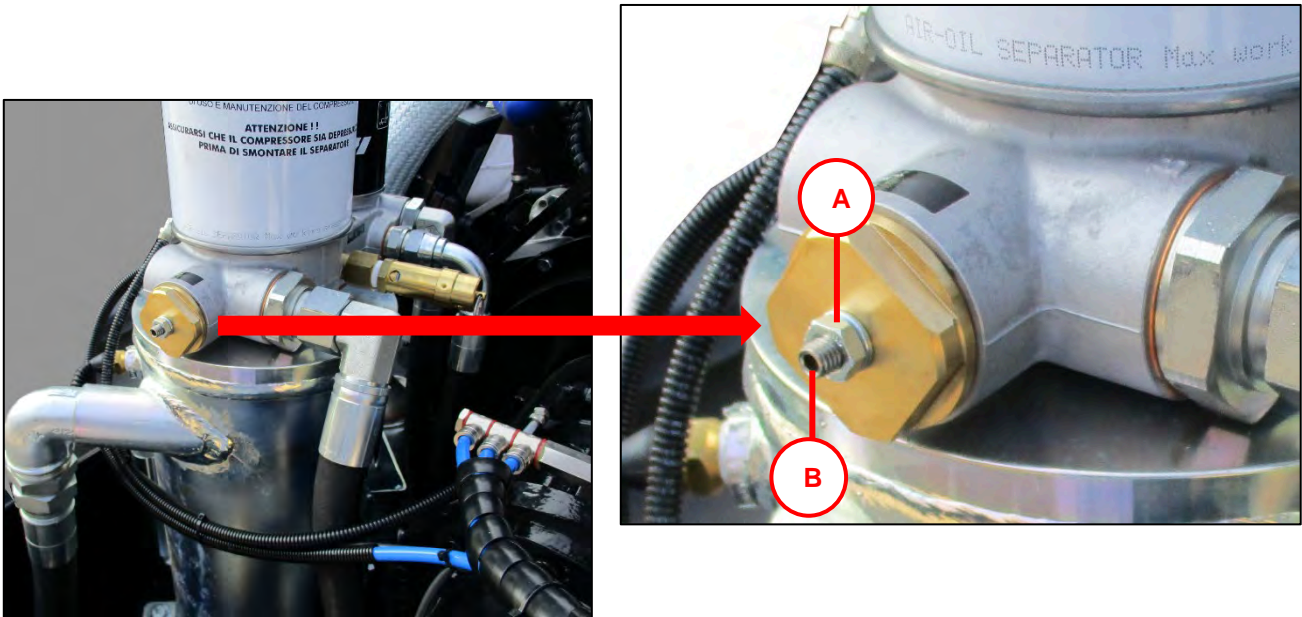

Figure 11.3-1 Adjusting minimum pressure pneumatic circuit

The minimum pneumatic pressure is calibrated during the testing phase of the machine.

If the minimum pressure pneumatic, indicated by the pressure gauge on the control panel, diverged over a  $\pm$  5% from the value specified in Paragraph 2 of this manual, proceed as follows:

1. Start the machine as described in section 10.2 Start.
2. Wait for the compressor to reach the maximum pressure and the engine stating the values of idle speed;
3. Gradually open the service valve (Letter A in Figure 10.2-1);
4. Open the canopy with the compressor in motion;
5. Unscrew, with 10 mm wrench, nut (Letter A Figure 11.3-1) located in the vicinity of the exhaust cleaner.
6. If you want to increase the maximum pressure must tighten the Allen screw (Figure 11.3-1 Letter B) with Allen key 3 mm;
7. If you want to reduce the pressure loosen the Allen screw (Figure 11.3-1 Letter B) with Allen key 3 mm;
8. Once the adjustment screw, with a 10 mm wrench, nut (Letter A Figure 11.3-1) and turn off the service valves;
9. Re-open slowly the air service valve (Letter A Figure 10.2 1) and close it again repeating the process a few times to allow the settling of the valve;
10. Close the canopy.



**WARNING:** Pressure vessel



	<b>USER AND MAINTENANCE MANUAL</b>	Date:	06/02/2025
		Code	MAN D185T4F ENG
<b>Motor compressor : D185T4F</b>		Revision	05

## 12 SAFETY DEVICES

### 12.1 Safety Valve Verification

The safety valve is located on the oil separator tank and it will relieve any pressure in the event that the machine might overpressure.

The calibration of this valve is performed and verified in the testing of the factory and cannot be varied for any reason or tampered with.

Its efficiency should be checked quarterly by doing the following:

- 1) Start the machine the machine as described in section 10.2 "Start"
- 2) With the valves closed and with the engine at idle speed, using forceps, pick up the pin, as shown in Figure and release it as soon as you have the perception that the valve exhausts air.

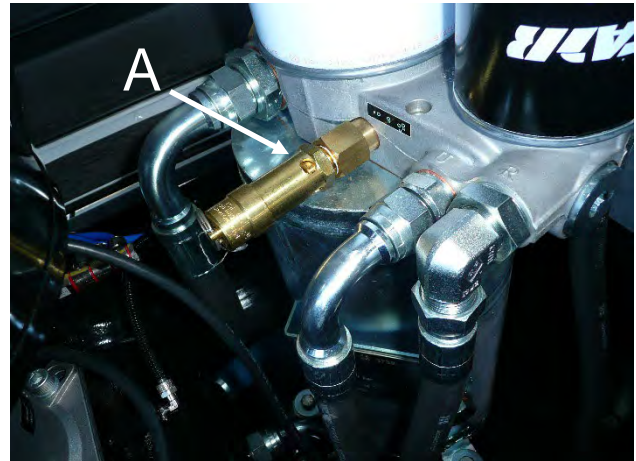
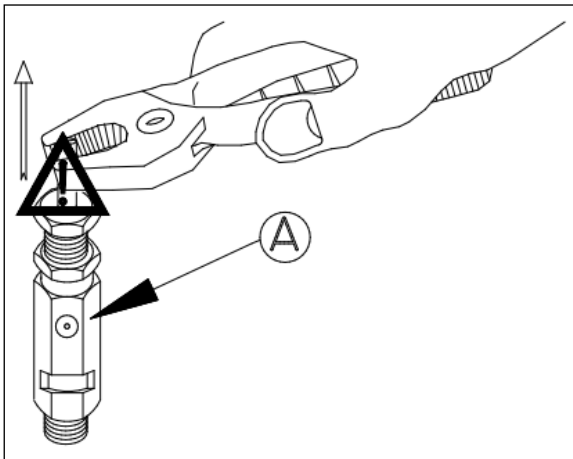

Figure 12.2-1 Control of the safety valve



**WARNING:** The air escaping from the valve during this operation control is also composed of small particles of oil.



**WARNING:** Pay attention to the danger of projection of liquids.



If, following the traction using a clamp, the pin is not raised, thus preventing the valve to vent, will require an immediate replacement of the safety valve.



In case of replacement, it is recommended to contact the ELGI service personnel, quoting the serial number of the machine.

*The use of a safety valve is not original and does not comply, then ELGI will be exempt from any liability.*



	<b>USER AND MAINTENANCE MANUAL</b>	Date:	06/02/2025
		Code	MAN D185T4F ENG
<b>Motor compressor : D185T4F</b>		Revision	05

## 13 MAINTENANCE



The machine must undergo regular periodic maintenance to preserve its technical characteristics and original safety standards.

Maintenance work must be performed by qualified personnel following approved patterns and designs, with the machine stopped and power disconnected from the electrical panel. All maintenance must be conducted only after the machine is fully powered down.



The staff of the service maintenance has to check that they have withdrawn their tools at the end of maintenance or repair and before starting the machine again, to avoid damage to the moving parts.

### 13.1 Routine Maintenance

Means of **routine maintenance**, all the maintenance actions that its sole objective was to bring back a system (or one of its components) from a state of failure, the state is working properly before the onset of the problem, without changing or improving the functions performed by the system, nor to increase the value, or improve performance.

Maintenance includes all those periodic operations including:

In the following chapter are listed in order of frequency, all transactions concerning the compressor part, while as regards the part of the engine, it will be necessary to refer to OPERATING AND MAINTENANCE, which is prepared by the manufacturer of the engine and that is as supplied with the machine



	<b>USER AND MAINTENANCE MANUAL</b>	Date:	06/02/2025
		Code	MAN D185T4F ENG
<b>Motor compressor : D185T4F</b>		Revision	05

### 13.2 Maintenance Program

In this program is a list of all the interventions and their frequency to be executed on the various components of the machine. Such interventions are essential for the proper functioning of the machine and its mechanical durability over time.

<i>RECOMMENDED OPERATIONS</i>	<i>FREQUENCY</i>
Checking the oil level compressor	Daily
Check engine oil level (refer to the manufacturer's manual)	Daily
Checking Coolant Level	Daily
Check fuel level and top up (if necessary)	Daily
Check oil or fuel leaks	Daily
Check operation of indicator lights	Daily
Check the readability of measuring instruments	Daily
Perform general cleaning operations	Daily
Check of any obstructions in the ventilation system	Daily
Check operation lights and license plate lights	Daily
Check the compressor air filter	Daily
Check the engine air filter	Daily
Thoroughly clean compressor and engine air filters	Daily
Check the battery electrolyte level	Monthly
Check tire pressure	Monthly
Check belt tension	Three months
Check the minimum and maximum engine speed control	Three months
Check the efficiency of the safety valve	Three months
Clean the radiator fins	Three months
Check the oil recovery nozzle	Three months
Drain the fuel tank	Three months
Check the efficiency of the braking system	Three months
Check the wheel lock	Three months
Replace the engine oil	at 50 hours and every 500 hours there after
Replace the engine oil filter	at 50 hours and every 500 hours there after
Replace the engine fuel filter	at 50 hours and every 500 hours there after
Replace the compressor oil filter	at 50 hours and every 500 hours there after
Replace compressor oil	at 50 hours and every 500 hours there after
Check the tightening of screws and bolts on the compressor and engine silent-blocks	Every 50 hours
Check the tightening of screws and bolts	Every 100 hours
Check the tightness of all pipe connections	Every 100 hours
Replace the compressor air filter	After 500 hours
Replace the separator filter	After 500 hours
Replace the engine air filter	After 500 hours

	<b>USER AND MAINTENANCE MANUAL</b>	Date:	06/02/2025
		Code	MAN D185T4F ENG
<b>Motor compressor : D185T4F</b>		Revision	05

<i>RECOMMENDED OPERATIONS</i>	<i>FREQUENCY</i>
Replace diesel pre-filter (If applicable)	After 500 hours
Check the ball valves by an authorized ELGI technician	Every 2 years
Check the readability of the machine nameplate	Every year
Perform service maintenance as per the required timeframe	

The ELGI disclaims any responsibility for the failure to comply with maintenance requirements in the table above.

### 13.2.1 Service Kit

#### 50 HOUR SERVICE KIT FOR D185T4F

Part #	Description	Quantity
<b>519-11-0001</b>	<b>50 HOUR SERVICE KIT</b>	<b>1</b>
<b>THE KIT INCLUDES</b>		
099-008-S	COMPRESSOR OIL FILTER	1
512-12-0000	COMPRESSOR OIL 2.5 GAL	1
511-21-0002	ENGINE FUEL FILTER	1
511-22-0000	ENGINE OIL FILTER	1
512-15-0007	10W30 SYNTH ENGINE OIL	1
<b>TOTAL:</b>		<b>5</b>

#### 250 HOUR SERVICE KIT FOR D185T4F

Part #	Description	Quantity
<b>519-21-0321</b>	<b>250 HOUR SERVICE KIT</b>	<b>1</b>
<b>THE KIT INCLUDES</b>		
099-008-S	COMPRESSOR OIL FILTER	1
162-0086-S	PRIMARY ENGINE AIR	1
162-0087-S	SECONDARY ENGINE AIR	1
162-576-S	COMPRESSOR AIR FILTER	1
162-577-S	COMPRESSOR SECONDARY AIR FILTER	1
512-12-0000	COMPRESSOR OIL 2.5 GAL	1
511-21-0002	ENGINE FUEL FILTER	1
511-22-0000	ENGINE OIL FILTER	1
512-15-0007	10W30 SYNTH ENGINE OIL	1
<b>TOTAL:</b>		<b>9</b>



	<b>USER AND MAINTENANCE MANUAL</b>	Date:	06/02/2025
		Code	MAN D185T4F ENG
<b>Motor compressor : D185T4F</b>		Revision	05

**500 HOUR SERVICE KIT FOR D185T4F**

Part #	Description	Quantity
<b>519-12-0007</b>	<b>500 HOUR SERVICE KIT</b>	<b>1</b>
<b>THE KIT INCLUDES</b>		
099-008-S	COMPRESSOR OIL FILTER	1
157-171-S	SEPARATOR FILTER	1
162-0086-S	PRIMARY ENGINE AIR	1
162-0087-S	SECONDARY ENGINE AIR	1
162-576-S	COMPRESSOR AIR FILTER	1
162-577-S	COMPRESSOR SECONDARY AIR FILTER	1
512-12-0000	COMPRESSOR OIL 2.5 GAL	1
511-21-0002	ENGINE FUEL FILTER	1
511-22-0000	ENGINE OIL FILTER	1
512-15-0007	10W30 SYNTH ENGINE OIL	1
<b>TOTAL:</b>		<b>10</b>



## 13.4 Maintenance Procedures

### 13.4.1 INSPECTING AND CLEANING AIR FILTERS AND INTAKE

This check should be performed periodically every 100 hours/weekly of work;



**If the machine operates in a very dusty environment, it will also be necessary on a daily basis.**

#### - COMPRESSOR AIR FILTER

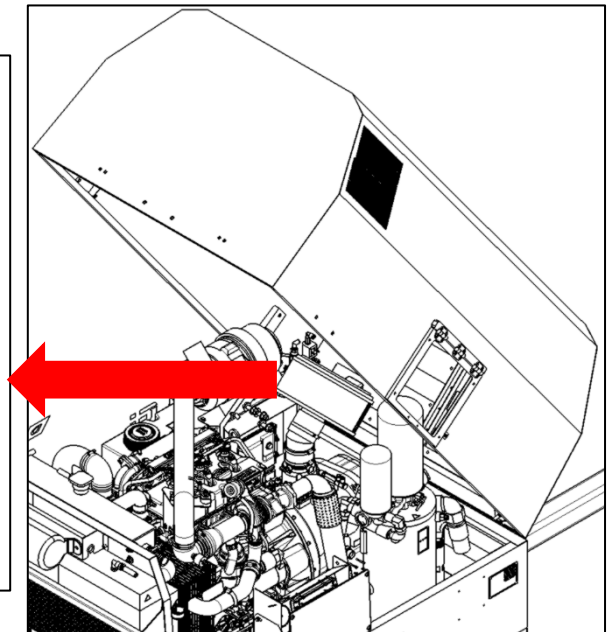
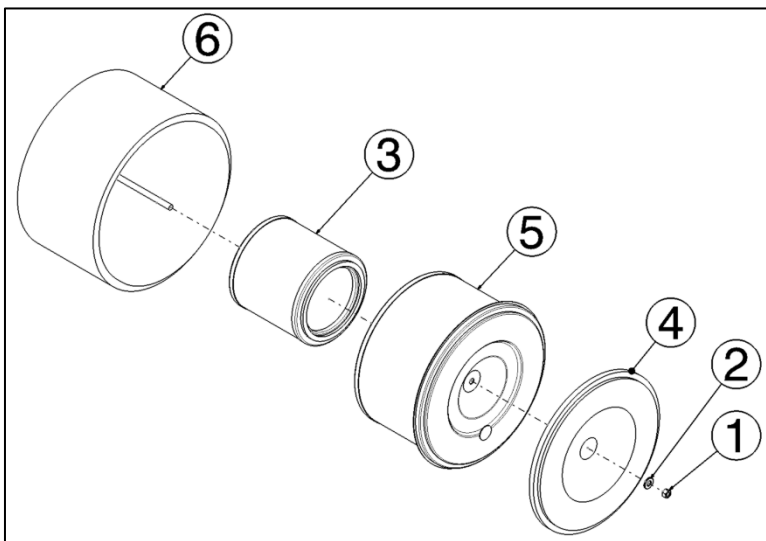

Figure 13.4-1 Aspiration air filter

- 1- Nut
- 2- Washer
- 3- 1<sup>st</sup> stage filter cartridge
- 4- Lid
- 5- 2<sup>nd</sup> stage filter cartridge
- 6- Air filter container

The filter consists of two filtering cartridges (1<sup>st</sup> and 2<sup>nd</sup> stage) for cleaning or replacement cartridges, proceed as follows:

1. Loosen the nut (fig.13.4-1 part 1 – 2 washer)
2. Remove the lid (fig.13.4-1 part 4)
3. Extract the cartridge of the 1<sup>st</sup> stage (fig.13.4-1 part 3)
4. Should any traces of dust be noticed on the cartridge of the 2<sup>nd</sup> stage (fig.13.4-1 part 5), extract this one also



**The filter cartridge must never be washed with water or other substances and never cleaned with compressed air but replaced;**



**It must, however, be replaced every 500 hours of work.**



	<b>USER AND MAINTENANCE MANUAL</b>	Date:	06/02/2025
		Code	MAN D185T4F ENG
<b>Motor compressor : D185T4F</b>		Revision	05

### 13.4.2 CHECKING THE ELECTRICAL BATTERY

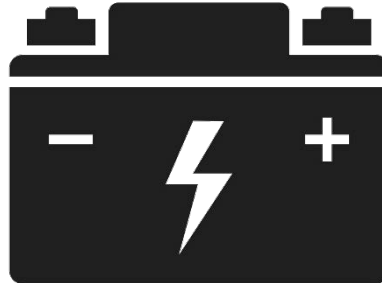

Figure 13.4-2 Battery



**Extended no-use of the machine - battery charge status**



- To avoid complete discharge of the battery, if the machine is not being used for > 3 months, disconnect the negative terminal of the electrical system.
- Periodically check the battery charge and recharge it every 3 months.

#### Cleaning the terminals

The battery terminals (poles) must be cleaned and greased periodically. The accumulation of dirt can hinder the passage of electric current.

For cleaning it is necessary to switch off the machine, disconnect the terminals starting from the negative terminal and clean the terminals.

#### Checking the clamps

Generally the negative and positive pole of the battery are greased (eg. Pulp vaseline or similar product) to avoid the oxidation of metals. The paste on the clamps must be periodically replaced.

In the same way, check that the terminals are firmly connected to the battery poles and if necessary tighten them. In fact, it may occur that vibrations can loosen the grip of the clamps. A poor connection can cause malfunctions and even failures to the vehicle's electrical devices.

#### Checking the battery fluid (in the case of an unsealed battery)

The electrolyte must always cover the element plates.

If the battery fluid is low, it may compromise its operation.

In these cases, if the level of covering is below the minimum level it is necessary to have it checked by a qualified electric maintenance technician and if necessary to provide the addition of cold water distilled water to restore the liquid level.

If, despite top-up, the battery continues to discharge frequently, it must be replaced.



**CAUTION: Take special care when handling battery fluid. Potentially corrosive liquid.**



	<b>USER AND MAINTENANCE MANUAL</b>	Date:	06/02/2025
		Code	MAN D185T4F ENG
<b>Motor compressor : D185T4F</b>		Revision	05

### 13.4.3 FUSE REPLACEMENT

Fuse replacement should be performed if one or both fuses are damaged or not functioning.

To replace the fuse proceed as follows:

- 1) Stop the machine;
- 2) Open the canopy;
- 3) Open the fuse box;
- 4) Pull the fuse to be replaced with tweezers (to fuse 15 A), and unscrew the screws for the 40 A fuse;
- 5) Once removed, observe the internal filament, this must be intact to function properly, if this is the case simply reinstall fuse. If this filament is sectioned into two this means the fuse should be replaced;
- 6) In the event of a damaged fuse replace it by choosing a fuse with identical characteristics. The characteristics of the fuses are described 8.3in this manual;
- 7) After inserting the new fuse in the housing close the fuse box;
- 8) Close the canopy;
- 9) Now you can restart the machine.



### 13.4.4 CLEANING THE RADIATOR AND COOLER

The compressor and motor coolants are cooled by a radiator, which must be kept clean to allow ventilation air to pass freely and easily through its honeycomb fins.

Radiator fins clogged with dust or any other bodies, can cause harmful and dangerous overheating to the mechanical screw compressor, greatly jeopardizing the operation and durability. We recommend that you check it periodically and, if necessary, clean it with compressed air or clean it with a jet of water under pressure.

### 13.4.5 COOLING LIQUID DOSAGE PERCENTAGE

To determine the proper amount of antifreeze to be added to the radiator you must (Figure 13.4-3) follow the following table:

T (°C / °F)	Total volume of the cooling plant	Water volume	Antifreeze volume	Antifreeze percentage*
(°C / °F)	(lt - gal)	(lt - gal)	(lt - gal)	%
- 10 / 14	14 – 3.70	10.5 – 2.80	3.50 – 0.90	25%
- 15 / 5	14 – 3.70	9,1 – 2.40	4,90 – 1.30	35%
- 20 / -4	14 – 3.70	7.7 – 2.00	6.3 – 1.0	45%

*\*Cooling liquid suggestions: PEAK EUROPEAN BLUE*



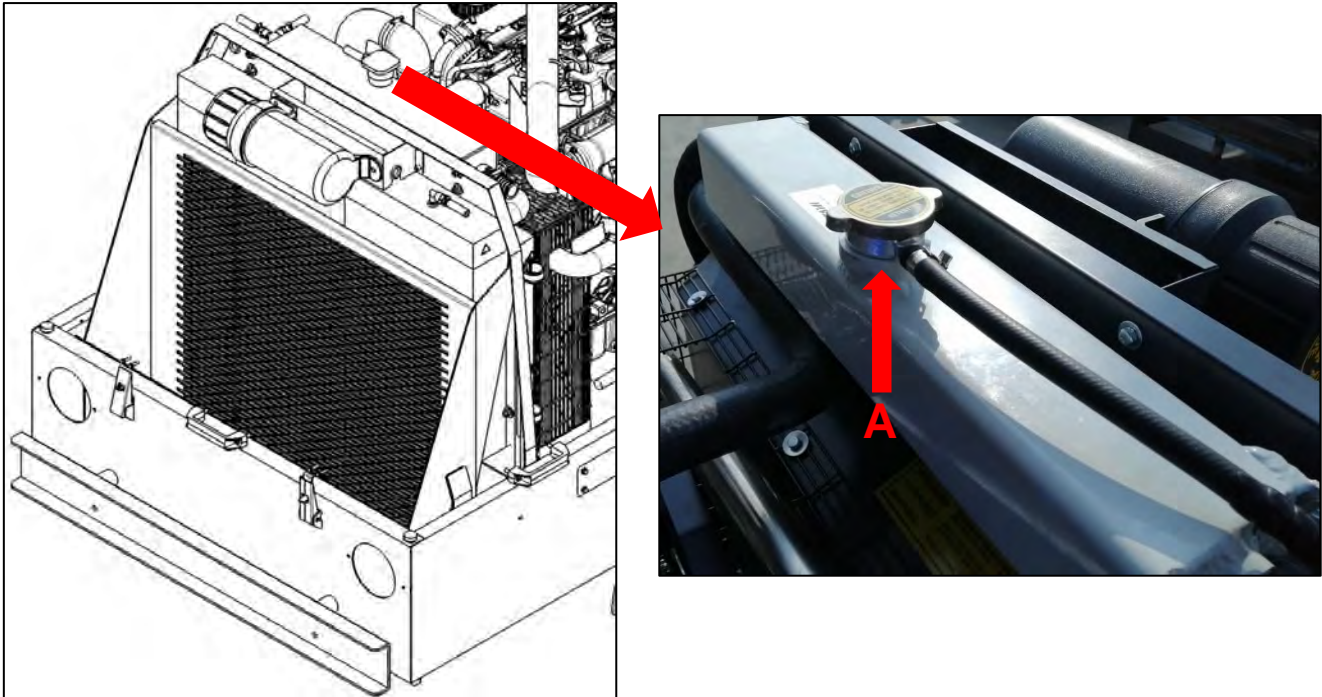

Figure 13.4-3 Checking the coolant radiator



**WARNING:** The radiator cap (Figure 13.4-3 - A) must never be removed on a warm engine: this condition would occur a sudden leakage, which could cause serious burns to the person. The filling must be done with a mixture of water and antifreeze liquid, in the percentage indicated on the label of the container .

### 13.4.6 CHECKING AND CLEANING THE OIL RECOVERY ORIFICE

If control and cleaning of the oil recovery nozzle is to be performed. Should you find a leak of oil mist mixed with compressed air, proceed with the following steps. (Figure 13.4-4).

- 1) Unscrew the fitting located at the center of the tank (Letter Z in Figure 13.4-4);
- 2) Inside the 90 degree fitting (Letter Z in Figure 13.4-4) is a nozzle (Letter U in Figure 13.4-4): make sure that its calibrated hole is not blocked (blow with compressed air);
- 3) Reinstall the fitting.



**WARNING:** During normal operation of the compressor, inside the transparent scavenger line, part (Z), you will notice a certain amount of oil flow from the said fitting (Z) towards the head of the compressor

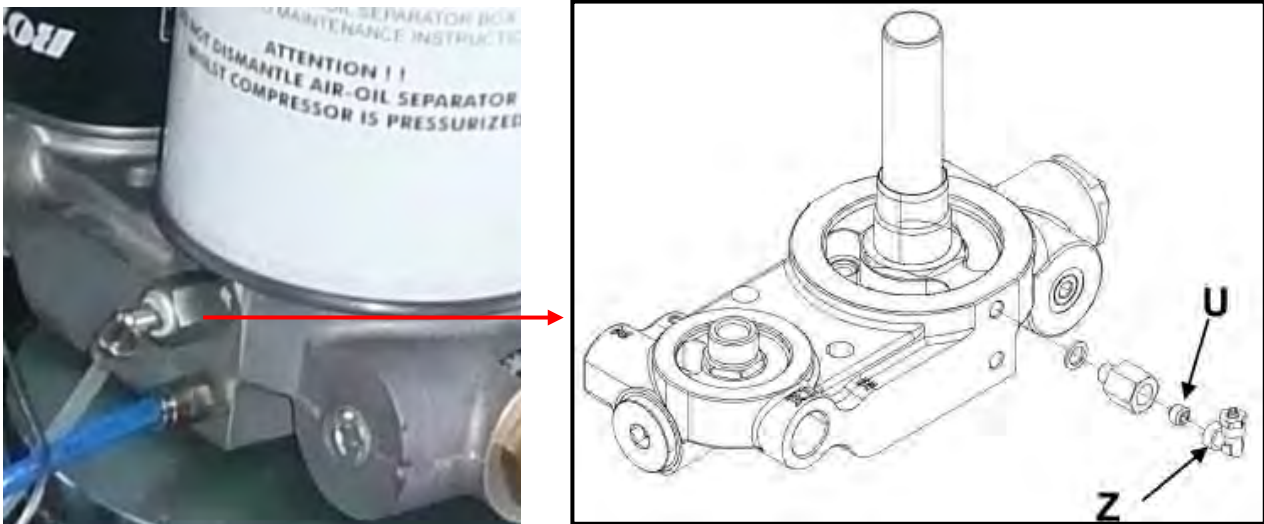

Figure 13.4-4 Oil recovery

### 13.4.7 FUEL TANK DRAINAGE

The purpose of draining the fuel tank is to remove any water that may have accumulated at the bottom of the tank due to condensation or contaminated fuel during refueling.

Avoid filling the fuel tank with cans, as they may contain traces of water. Since water is heavier than diesel, it can settle at the bottom and accumulate to the level of the dip tube.



Periodically perform drains to prevent even small amounts of water from being aspirated and injected into the engine.

It is also advisable to refuel at the end of the work shift to prevent temperature fluctuations in the tank walls, which could lead to the formation of condensation inside the tank.

Along with draining the tank, also replace the fuel filter to remove any traces of water from the fuel.

	<b>USER AND MAINTENANCE MANUAL</b>	Date:	06/02/2025
		Code	MAN D185T4F ENG
<b>Motor compressor : D185T4F</b>		Revision	05



The draining of the tank must be performed at least 30 minutes after stopping the machine, to allow water to separate from the diesel fuel and to settle to the bottom of the tank.

The polluted fuel spilled from the purges should be collected and delivered to specialized centres and authorized collection and disposal of hazardous waste.



*Remember that the residual fuel should not be totally discarded in the environment.*

#### 13.4.8 REPLACING THE DIESEL FILTER AND PRE-FILTER



As for the controls of the engine and replacing diesel filter, timing belt, motor oil, and other specific controls refer to the owner's manual of the engine manufacturer attached to this documentation.

#### 13.4.9 CHECKING THE WHEEL BOLT TIGHTNESS

Periodically check the tightness of the wheel bolts using a spanner, avoiding the use of air screwdrivers that may damage the bolt threads.



	<b>USER AND MAINTENANCE MANUAL</b>	Date:	06/02/2025
		Code	MAN D185T4F ENG
<b>Motor compressor : D185T4F</b>		Revision	05

#### 13.4.10 COMPRESSOR OIL FILTER REPLACEMENT

For proper compressor oil filter replacement, follow these steps:

- 1) Stop the machine and open the hood of the engine compartment;
- 2) Use a chain wrench to unscrew the filter to be replaced (Figure 13.4-6);
- 3) Oil the seal of the new filter to be tightened and only by hand;
- 4) Start the machine and ensure there are no oil leaks around the seal. If any leaks are detected, stop the machine immediately and recheck the seal's condition and its correct positioning in the housing.

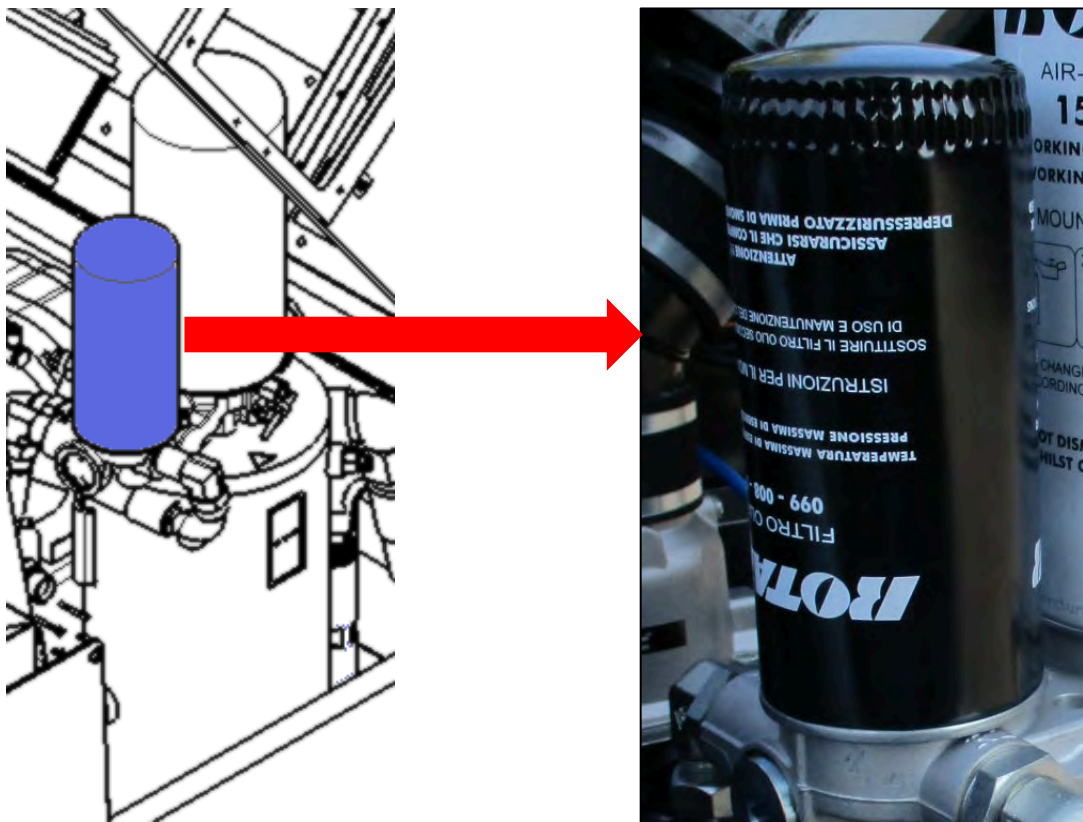

Figure 13.4-6 Compressor oil filter



**WARNING:** The filter is impregnated exhausted mineral oil pollution and harmful to the environment, therefore it must be disposed of at specialized centres of collection and treatment of waste.



**13.4.11 COMPRESSOR OIL REPLACEMENT**

The compressor oil change must be performed considering the operating conditions of the machine (e.g., dusty environments, very high temperatures). Oil change intervals should never exceed 50 or 500 working hours. Along with the oil change, the corresponding filter must also be replaced (refer to Paragraph 13.4.12).

RECOMMENDED OIL	QUANTITY	PART NUMBER
AIRLUBE PORTABLE LUBRICANT	2.5 Gallons	512-12-0000
	5 Gallons	512-12-0001
	55 Gallons	512-12-0002
	330 Gallons	512-12-0003

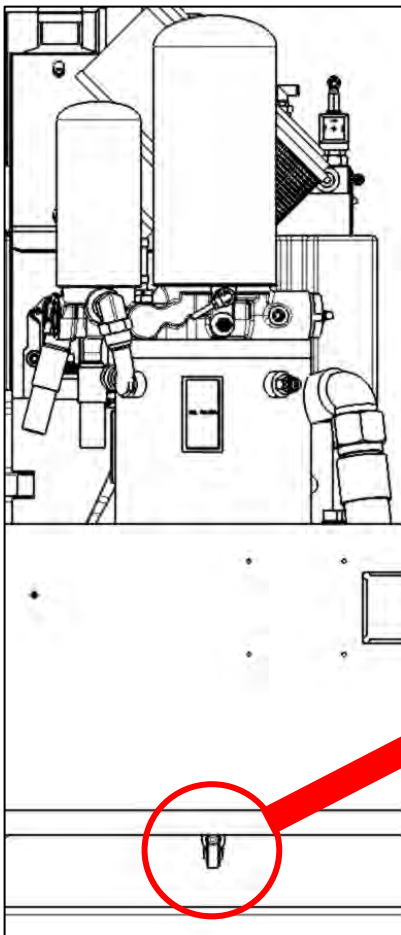

**WARNING:** It is strictly recommended to use ONLY ELGI AIRLUBE.  
ELGI declines any responsibility if other oils will be used.



	<b>USER AND MAINTENANCE MANUAL</b>	Date:	06/02/2025
		Code	MAN D185T4F ENG
<b>Motor compressor : D185T4F</b>		Revision	05

### 13.4.12 CHECKING THE OIL MIST SEPARATOR

Separator filter life is expected around 500 hours of work, but is closely related to a careful observance of all maintenance requirements given in this manual.

If the unit has low compressor oil, breach of maintenance intervals, or the radiator is clogged with foreign debris, this may determine an anticipated and irreparable deterioration of the filters.

Therefore, if, after the control and cleaning of the oil recovery nozzle (operation described in the paragraph 13.4.8) and making sure the proper oil level is in the tank, you find traces of oil in the compressed air, you will have to replace the air/oil separator filter..

To ascertain the degree of clogging of the filter separator operate as follows:

- 1) Install a pressure gauge upstream of the separator and make sure that the gauge is installed securely.
- 2) Start the machine.
- 3) Partially open the ball valve until the pressure gauge on the control panel shows the value of the operating pressure.
- 4) Read the value of the pressure gauge located upstream of the oil separator filter and compare two values: if, between the two readings, there is a difference of more than 1 bar replace the filter separator.

The air/oil separator filter must never be washed with water.



**WARNING:** *Pressure vessel*

### 13.4.13 REPLACING THE OIL SEPARATOR FILTER

To replace the oil separator filter proceed as follows:

- 1) The operation must be performed with the machine stopped and in the absence of pressure in the oil separator tank.
- 2) We recommend applying a cloth in order to contain any oil leakage that may occur during the replacement of the oil filter.
- 3) Unscrew the oil separator filter: the filter is situated above the oil separator tank
- 4) Replace the new filter making sure to lubricate the gasket.
- 5) The filter must be tightened by hand only.

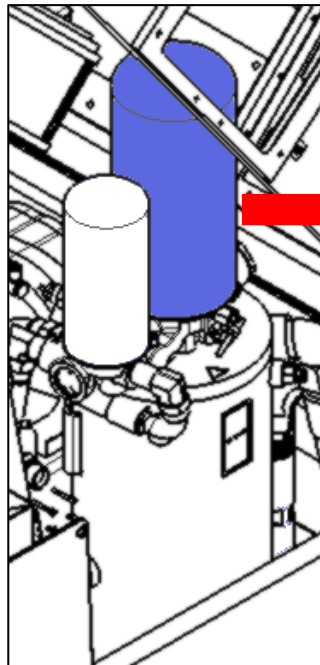



Figure 13.4-7 Oil separator filter



**WARNING:** *Pressure vessel*



	<b>USER AND MAINTENANCE MANUAL</b>	Date:	06/02/2025
		Code	MAN D185T4F ENG
<b>Motor compressor : D185T4F</b>		Revision	05

#### 13.4.14 ENGINE INSPECTION AND MAINTENANCE



As for the controls of the engine and replacing diesel filter, timing belt, motor oil, and other specific controls refer to the owner's manual of the engine manufacturer attached to this documentation.

## 14 SPARE PARTS



In case you need to order a single component contact your authorized service center ELGI.



	<b>USER AND MAINTENANCE MANUAL</b>	Date:	06/02/2025
		Code	MAN D185T4F ENG
<b>Motor compressor : D185T4F</b>		Revision	05

## 15 FAULTS AND TROUBLESHOOTING

Abnormal	Cause	Solution
The engine will not start.	Battery discharged or defective.	Recharge and replace if necessary.
	Terminals of the battery cables oxidized or loose.	Clean battery posts and tighten as necessary.
	No fuel.	Top up the fuel in the diesel tank.
	Solenoid faulty fuel.	Contact the engine manufacturer's customer service for assistance.
	Air in the fuel pipe.	Locate the infiltration by careful verification of all pipes.
	Injection pump defective.	Contact the engine manufacturer's customer service for assistance.
Opening the service valves the motor does not accelerate.	Control valve of maximum pressure defective.	They are located at: - Cylinder head of engine; - Bottom side or airend endcap; - Tank separator. One at a time, unplug its power cable from the sensor to identify the defective sensor and replace it. The temperature light on the control panel should go off.
		Contact the engine manufacturer's customer service for assistance.
The engine speeds up but no air come out	Minimum pressure control valve blocked.	Remove the max pressure control valve and accurately control the spring and the conical seat. If the defect cannot be repaired, the valve must be replaced.  Disassemble and check that the piston is free to move. Check that the spring is intact. If the defect cannot be repaired the valve must be replaced. Reassemble and adjust the minimum pressure following the instructions in Section 11.3.

The machine stops suddenly and can only be restarted after a few minutes of waiting.

A temperature sensor detects a temperature anomaly and consequently stops the machine.

Take off one at a time, locate the sensor that determines the stop. If that proves to be placed on the engine, check the oil level of the motor, the voltage and the conditions of the alternator belt. For water-cooled engines, check the coolant level.  
If it turned out to be the probe placed on the compressor control the level of 'oil in the tank and



	<b>USER AND MAINTENANCE MANUAL</b>	Date:	06/02/2025
		Code	MAN D185T4F ENG
<b>Motor compressor : D185T4F</b>		Revision	05

Abnormal	Cause	Solution
		if necessary top up; Check the cooling fan and clean the radiator; replace the oil filter of the compressor. If that proves to be positioned on the oil separator tank, check the oil separator filter following the instructions to Par. 13.4-15, proceeding to its eventual replacement Par 13.4-16.
Abnormal	Cause	Solution
The engine does not reach the maximum speed	The spring piston accelerator is broken or to be put under tension.	Check the tension of the spring piston accelerator (Par. 11.1.2).
	Engine speed lower than expected.	Have the injection apparatus of the motor checked by qualified personnel. Replace the fuel filter. Run the draining of the fuel tank (Par. 13.4.9).
Oil leaking from the service valves.	Minimum working pressure too low.	Adjust it according to the instructions of Par. 11.3.
	Too much oil in the tank.	To the correct level (Par.13.4).
	The machine works in non-horizontal position.	Ensure the machine is level with the ground.
	Nozzle clogged oil recovery.	See Par. 13.4.8.
	Defective exhaust cleaner.	See Par. 13.4.15.

	<b>USER AND MAINTENANCE MANUAL</b>	Date:	06/02/2025
		Code	MAN D185T4F ENG
<b>Motor compressor : D185T4F</b>		Revision	05

## 16 MACHINE DISPOSAL AND DECOMMISSIONING

### 16.1 Dismantling Instructions

Safe Machine Dismantling Procedure

- 1) Prepare the Work Area – Ensure the machine is placed in a spacious, stable location and turned off.
- 2) Drain Fluids – Empty all liquid waste, including motor oil, fuel, coolant, and hydraulic oil, into designated containers. Refer to the following section for proper disposal guidelines.
- 3) Remove Covers – Loosen and remove the screws securing the body covers, then carefully detach them.
- 4) Disassemble Components – Remove each component systematically, sorting them based on their material composition.
- 5) Properly dispose of each part according to the applicable waste category.

#### Waste Categories

The following types of waste may be generated during the machine's life-cycle and must be disposed of appropriately:

- Used motor oil
- Used compressor oil
- Coolant residues
- Residual fuel
- Battery fluid remnants
- Rags or paper contaminated with solvents or other cleaning agents

## 17 MACHINE DECOMMISSIONING

The operations of destruction and disposal must be carried out in a safe condition by a qualified specialist and after carefully reading and incorporated the recommendations and instructions provided in this section of the manual of use and maintenance and consulting the safety data sheets relating to substances in the machine mentioned in the previous chapter..

Once you reach the end of the mechanical life of the compressor, this has to be taken out of service so that it cannot be used for other purposes.



## 18 WASTE MANAGEMENT



The withdrawal of special waste and / or hazardous materials should be entrusted with the written contract to authorized firms; and those who physically transport and handle this waste must be in possession of the required authorizations. The haulers must be an authorized company that specializes in waste management.

### 18.1 Special Waste

They are considered a hazardous waste residue from industrial, agricultural, crafts, commercial and service, for quality or quantity, is declared similar to municipal waste. These include also: machinery, equipment and metal parts of engines deteriorated and obsolete.



### 18.2 Toxic And Hazardous Waste



Are considered hazardous toxic waste all waste containing or contaminated by the substances listed in Directives 75/442 / CEE, 76/403 / CEE and 768/319 / CEE or other regulations in the countries of use and installation of the machines.



### 18.3 Temporary Storage



Are considered hazardous toxic waste all waste containing or contaminated by substances listed in Directives 75/442 / CEE, 76/403 / CEE and 768/319 / CEE or other regulations in the countries of use and installation of the machines.

Temporary storage of toxic and hazardous waste is allowed according to the expected disposal of waste by treatment and / or final disposal. In any case, observe the mandatory laws of the country of the user in the field of environmental protection.

### 18.4 Container Specifications

The fixed and mobile containers, designed to contain toxic and hazardous waste must possess adequate strength requirements in relation to the chemical-physical properties and to its hazardous characteristics of the waste contained. The containers which hazardous materials are stored must disclose the nature of their contents via labels or markings on the container.



### 18.5 Registration and Documentation Requirements

In accordance with the EU Directive 75/439 / CEE on the disposal of waste oil, the records of loading / unloading must be kept by all companies that produce hazardous waste or hazardous toxic from industrial and artisanal (in each case the 'Users should refer to the regulations implementing that Directive in the country of installation and use of the machines).



# USER AND MAINTENANCE MANUAL

Date:	06/02/2025
Code	MAN D185T4F ENG
Revision	05

Motor compressor : D185T4F

## 19 ELGI PRODUCT WARRANTY INFORMATION

### 19.1 Warranty Term and Conditions

Rotair Model	Full Machine Warranty	Engine Brand & Model	Engine Warranty	Airend Warranty
GP35FP	12 Months or 2,000 Hrs.	Vanguard Model 38	36 Months/ Unlimited Hrs.	60 Months & Unlimited Hrs.
GP75H	12 Months or 2,000 Hrs.	Honda GX690	36 Months/ Unlimited Hrs.	60 Months & Unlimited Hrs.
D90KA	12 Months or 2,000 Hrs.	Kubota D1105	24 Months or 4,000 Hrs.	60 Months & Unlimited Hrs.
D185T4F	12 Months or 2,000 Hrs.	Kohler KDI 1903	36 Months or 2,000 Hrs.	60 Months & Unlimited Hrs.
DS185T4F	12 Months or 2,000 Hrs.	Kohler KDI 1903	36 Months or 2,000 Hrs.	60 Months & Unlimited Hrs.
D300T4F	12 Months or 2,000 Hrs.	Kohler KDI 2504	36 Months or 2,000 Hrs.	60 Months & Unlimited Hrs.
D400T4F	12 Months or 2,000 Hrs.	Cummins QSF 3.8	24 Months or 2,000 Hrs.	60 Months & Unlimited Hrs.
D425T4F	12 Months or 2,000 Hrs.	Cummins QSF 3.8	24 Months or 2,000 Hrs.	60 Months & Unlimited Hrs.
D800T4F	12 Months or 2,000 Hrs.	FPT N67	24 Months or 2,000 Hrs.	60 Months & Unlimited Hrs.

ELGi North America

4610-A Entrance Dr., Charlotte, NC 28273 | T 704 523 4123 | E [portableservice@elgi.com](mailto:portableservice@elgi.com) | W: [www.elgi.us](http://www.elgi.us)

**Warranty Terms Policy on next page**



Copyright © 2014, ROTAIR S.P.A. - All rights reserved This manual is intellectual property of ROTAIR S.P.A. Its full or partial reproduction is forbidden under any form, on any support and by any means, without the written authorization by ROTAIR S.P.A.

Page 78/83



## USER AND MAINTENANCE MANUAL

Date:	06/02/2025
Code	MAN D185T4F ENG
Revision	05

**Motor compressor : D185T4F**

### Warranty Terms on Engine Driven Air Compressors

#### HEREBY KNOWN AS THE PRODUCT/S

- 1) ROTAIR SPA/ ELGi NA provides a warranty to the constructor/user, ensuring that the products are free from defects in design, materials, and workmanship within the normal tolerance levels. This warranty is applicable as long as the products are used within their technical and performance specifications and in compliance with the instructions provided in the user and maintenance manual. It's important to note that this warranty is subject to the normal rules of diligence and prudence.
- 2) For the products in their original state, including all accessory fittings, the warranty period is one year for Rotair parts from the date of putting the product into operation by the end user (commission date). On the other hand, the warranty period for the ELGi Airend is five years from the date on which it is put into operation. It's important to note that the warranty card, which will be included with the product user manual, will serve as valid proof of warranty.
- 3) If the commissioning date of the product is not available, an additional 6 months will be added to the actual warranty term for the parts. This additional time accounts for transit time and stock. For Rotair parts, the warranty term will be extended to 18 months, and for ELGi airend, the warranty term will be extended to 66 months. In this scenario, the warranty term will start from the shipping date from Rotair. However, for the engine, the warranty terms of the manufacturer should be referred to.
- 4) If the products are owned by retailers or distributors and intended for rental purposes, the date when the product is actually put into service will remain valid for warranty purposes. Additionally, the ROTAIR SPA/ELGi sales invoice, along with the warranty registration, will also be considered valid. This means that the warranty coverage will be based on the date of putting the product into service and the corresponding sales invoice and warranty registration.
- 5) The warranty period for spare parts is 6 months from the date of delivery to the end client, as indicated in the sales invoice. However, it's important to note that spare parts subject to normal wear, as specified further in the document, are not covered by the warranty terms. It's also worth mentioning that the warranty terms will not be suspended or extended due to machine stoppages, even if those stoppages are caused by repairs made under warranty.
- 6) THE WARRANTY IS EXEMPT IN CASES OF:
  - I. Product damage during transportation.
  - II. Damage arising from the improper use of the product in relation to the technical features imposed by the manufacturer.
  - III. Use on machines or tools not in accordance with the instructions laid down by the manufacturer.
  - IV. Improper or impertinent use in relation to the anticipated uses.
  - V. Failure to perform the necessary regular maintenance as outlined in the product or failure to take the necessary precautions to protect the product when it is not used.
  - VI. Damage caused as the result of accidents such as dropping the compressor, fire, accidental causes, negligence and all other causes which are not the direct result of an original product defect.
  - VII. Defects arising as the result of modifications, alterations, repairs or



- replacements undertaken by non-authorized personnel.
- VIII. Damage as the result of the use of non-original parts, components and/or accessories.
- IX. Damage arising as the result of the failure to follow the instructions and/or indications contained in the user and maintenance manual, or in any event supplied by the constructor to ensure the correct installation and repair of the product.
- X. Normal wear & tear of the product parts.
- XI. The worsening of damage as the result of the continued use of the product by the client once the defect has already become apparent.
- XII. The failure of the client to meet his payment obligations.
- XIII. Delay in defect notification by the client (over 15 days).
- XIV. Failure to send the manufacturer the guarantee/consignment certificate duly compiled within ten 10 (days) of product consignment to the end user
- XV. Failure on the part of the dealer to send the User Operations and Maintenance Manuals along with the product to the end user.
- 7) The manufacturer's warranty provided to the product dealer/user covers only repair work performed at an authorized workshop for the original client-user. The manufacturer will reimburse only the labor costs, excluding all other expenses such as travel, daily living, and transfer costs. Reimbursement will cover only the hourly labor costs for repairs conducted at the dealer's premises or an authorized service center. All repairs must use OEM spare parts purchased from the manufacturer; otherwise, the warranty will be void.
- 8) Defective parts replaced under warranty must be kept at the dealer's premises or authorized workshop for 90 days. If the manufacturer does not request the return of these defective parts within this period, the dealer or authorized service center may dispose of them without further communication to the manufacturer. If the manufacturer requests the return of any defective or replaced parts within the 90-day period, failure to return them will result in the consignee being invoiced for the parts.
- 9) The delivery of spare parts covered under warranty will be at the manufacturer's expense using a non-express courier. Any urgent shipments will be at the expense of the receiver or end user, unless authorized by ELGi.
- 10) The parts of the product subject to normal wear include: cooling and lubrication liquids, tires, air/oil filters, air/oil separator filters, belts, and other normal maintenance items or consumable products.
- 11) The engine is covered exclusively by the warranty terms and conditions specified by the engine manufacturer. Rotair & ELGi NA are therefore exempt from any responsibility or damage claims resulting from engine defects or malfunctions. ELGi can provide information on certified service centers if needed.



**USER AND  
MAINTENANCE MANUAL**

<b>Date:</b>	<b>06/02/2025</b>
<b>Code</b>	<b>MAN D185T4F ENG</b>
<b>Revision</b>	<b>05</b>

**Motor compressor : D185T4F**

12) OPERATIONAL PROCEDURES FOR ENGINE-DRIVEN COMPRESSOR REPAIRS DURING THE WARRANTY PERIOD:

The manufacturer grants the dealer and/or authorized service center a negotiated labor rate for authorized warranty repairs. The maximum total amount for labor costs covered during the warranty period will not exceed 5% of the purchase cost paid by the original buyer.

13) PROCEDURE FOR REQUESTING WARRANTY PARTS AND EXPENSE REFUNDS:

When requesting warranty parts, the dealer or authorized service center must submit the WARRANTY CLAIM FORM on Page 9, which must include the following details: product model, serial number, date of operation at the user's premises, actual working hours, and the defect found. Upon the manufacturer's acceptance of the warranty claim for the shipment of the required parts, the repairing party must send the WARRANTY CLAIM FORM to ELGi NA. The form should be completed, including the LABOR section, and signed by an authorized service technician. ELGi NA will then, at its discretion, authorize the payment of expenses incurred in correcting the defect. LABOR COST CHARGES WILL NOT BE ACCEPTED WITHOUT PRE-AUTHORIZATION OF THE WARRANTY CLAIM FORM.

Should the Warranty Claim Form for refunding of the labor costs met by the dealer and/or authorized Service Center is not presented within 30 days of the repair work, all rights to refunding of the labor costs involved will become void.

14) If the dealer provides assistance services through an external service center authorized by ELGi, the external service center will be automatically authorized to monitor warranty work and procedures. The dealer will be able to make direct refunds to the external service center for the warranty work performed.

15) This warranty constitutes the only Warranty Claim Form provided by the manufacturer and is limited solely to the faults and defects specifically anticipated. It excludes and replaces, to the extent permitted by law, all other forms of warranty, whether explicit or implicit, legal or conventional. It also excludes any form of compensation for direct, indirect, incidental, or consequential damages.

16) The dealer or user expressly accepts this warranty according to its terms, limits, and exclusions as indicated above. They acknowledge that, aside from what is specifically indicated, no other claims may be made against the manufacturer, whether in a contractual or non-contractual context, either directly or indirectly, regarding any product defects or faults.

ELGi Portable Compressor - 4610 Entrance  
 Dr. STE A Charlotte, NC 28273  
 PH: 704-523-4123  
 Email: [portableservice@elgi.com](mailto:portableservice@elgi.com)  
 Web: [www.elgi.us](http://www.elgi.us)

ROTAIR SPA - Via Bernezzo, 67 /12023  
 CARAGLIO, Italy - C.C.I.A.A. n. 85673 -  
 Partita I.V.A. n. 00210890042  
 PH: +39 0171-619676  
 Email: [info@rotairspa.com](mailto:info@rotairspa.com)  
 Web: [www.rotairspa.com](http://www.rotairspa.com)



	<b>USER AND MAINTENANCE MANUAL</b>	Date:	06/02/2025
		Code	MAN D185T4F ENG
<b>Motor compressor : D185T4F</b>		Revision	05

## 19.2 Summary of the Warranty Conditions for Repair

### Summary of the conditions for repairs under warranty are as follows:

1. The warranty term granted by the manufacturer relates solely to repair work under warranty undertaken at an authorized workshop in relation to the first client-user.
2. The manufacturer will reimburse expenses solely for the labor involved in the repairs, to the total exclusion of all other costs such as traveling expenses, daily living expenses, and transfer costs.
3. All repairs must be made using OEM spare parts purchased from the manufacturer; otherwise, the warranty will become void.
4. The defective spares replaced under warranty must be kept at the dealer's premises or authorized workshop for a period of 90 days.
5. If, after the 90-day period, the manufacturer does not specifically request the return of the defective parts, the dealer and/or authorized service center may dispose of them without further communication to the manufacturer.
6. The failure to return any defective or replaced parts, as requested by the manufacturer within the 90-day time limit, will result in the parts being invoiced to the consignee.
7. The delivery of spares covered under warranty is at the expense of the manufacturer using a non-express courier. Any urgent shipment will be at the expense of the receiver or end user, unless authorized by ELGi.
8. The warranty claim form must be filled out and submitted to ELGi NA for authorization of labor cost reimbursement before any repairs are undertaken.
9. The warranty claim form for refunding labor costs must be presented within 30 days of the repair work; otherwise, the rights to refunding labor costs will become void.
10. If the dealer provides assistance services through an external Service Center authorized by ELGi, the external service center will be authorized to monitor warranty work and procedure and make the refund directly to them.

These conditions outline the process and requirements for repairs under warranty.





**USER AND  
MAINTENANCE MANUAL**

Date: 06/02/2025

Code MAN D185T4F ENG

Motor compressor : D185T4F

Revision 05

**19.3 Warranty Registration Card**



**WARRANTY REGISTRATION CARD**

Machine Model:

Serial Number:

Purchase Date:

Commission Date:

Distributor Name:

Contact & Phone Number:

Address:

Customer Name:

Installation Address:

Contact:

Phone Number:

Email Address:

Completion Date:

IMPORTANT: THE CARD SHALL BE COMPLETED AND SENT TO ELGI NORTH AMERICA; MISSING DATA OR THE NON-COMPLIANCE WITH MAILING REGISTRATION ENTAIL THE LOSS OF WARRANTY. COPY SHALL BE MADE AND KEPT AT THE CARE OF THE CUSTOMER.





# PARTS LIST

Motorcompressor - D185T4F

Revision: 04

28/04/2025

# PARTS LIST

## MOTORCOMPRESSOR

**D** *185T4F*



4610 Entrance Drive St A - Charlotte, NC 28273

PHONE: 704-523-4123

E-MAIL: [Portableservice@elgi.com](mailto:Portableservice@elgi.com) - [Portablesales@elgi.com](mailto:Portablesales@elgi.com);

Copyright © 2014, ROTAIR S.P.A. - All rights reserved This manual is intellectual property of ROTAIR S.P.A. Its full or partial reproduction is forbidden under any form, on any support and by any means, without the written authorization by ROTAIR S.P.A.



# D185T4F - Dimensions

Tab. 01.0

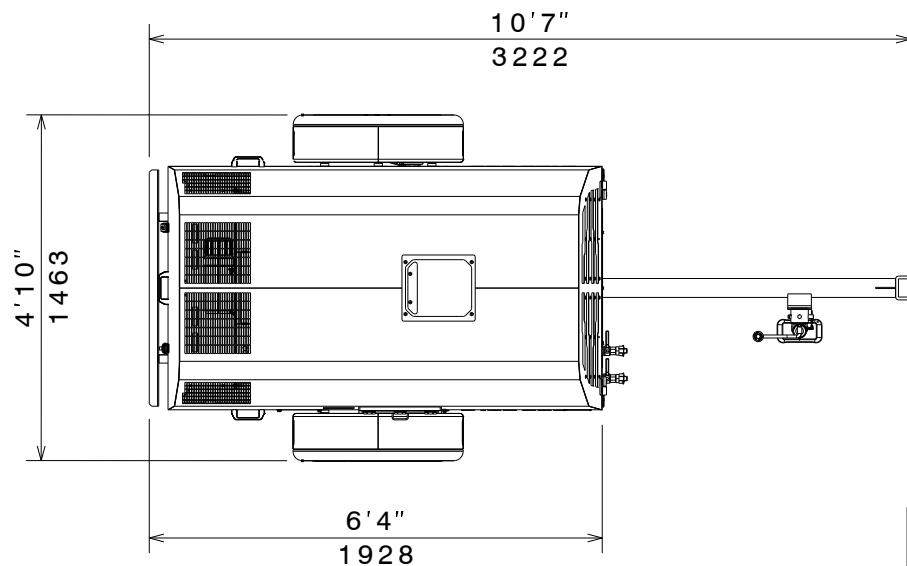
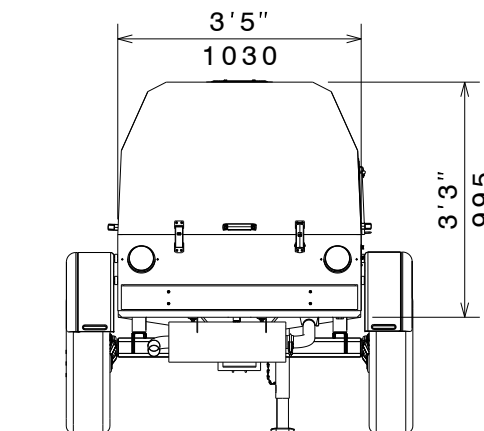
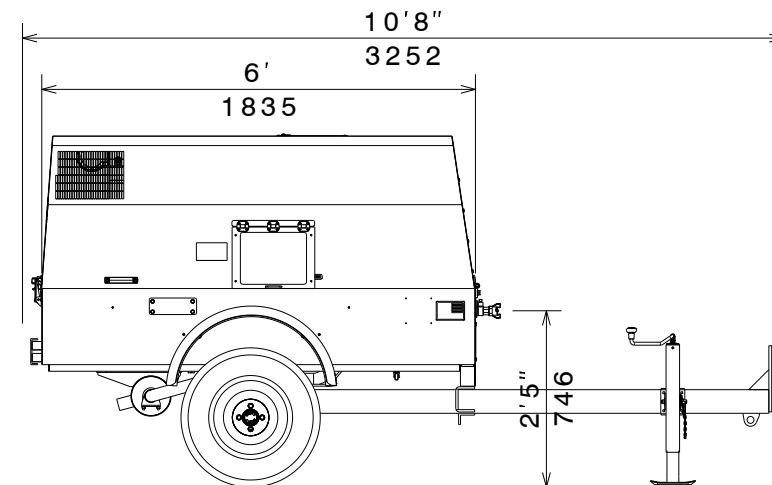
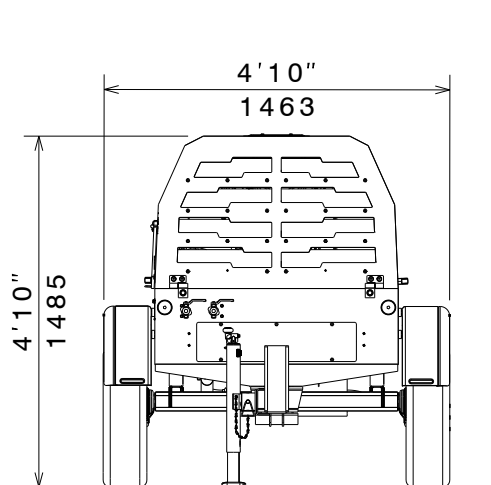

Feet/Inches  
mm



This page has been intentionally left blank

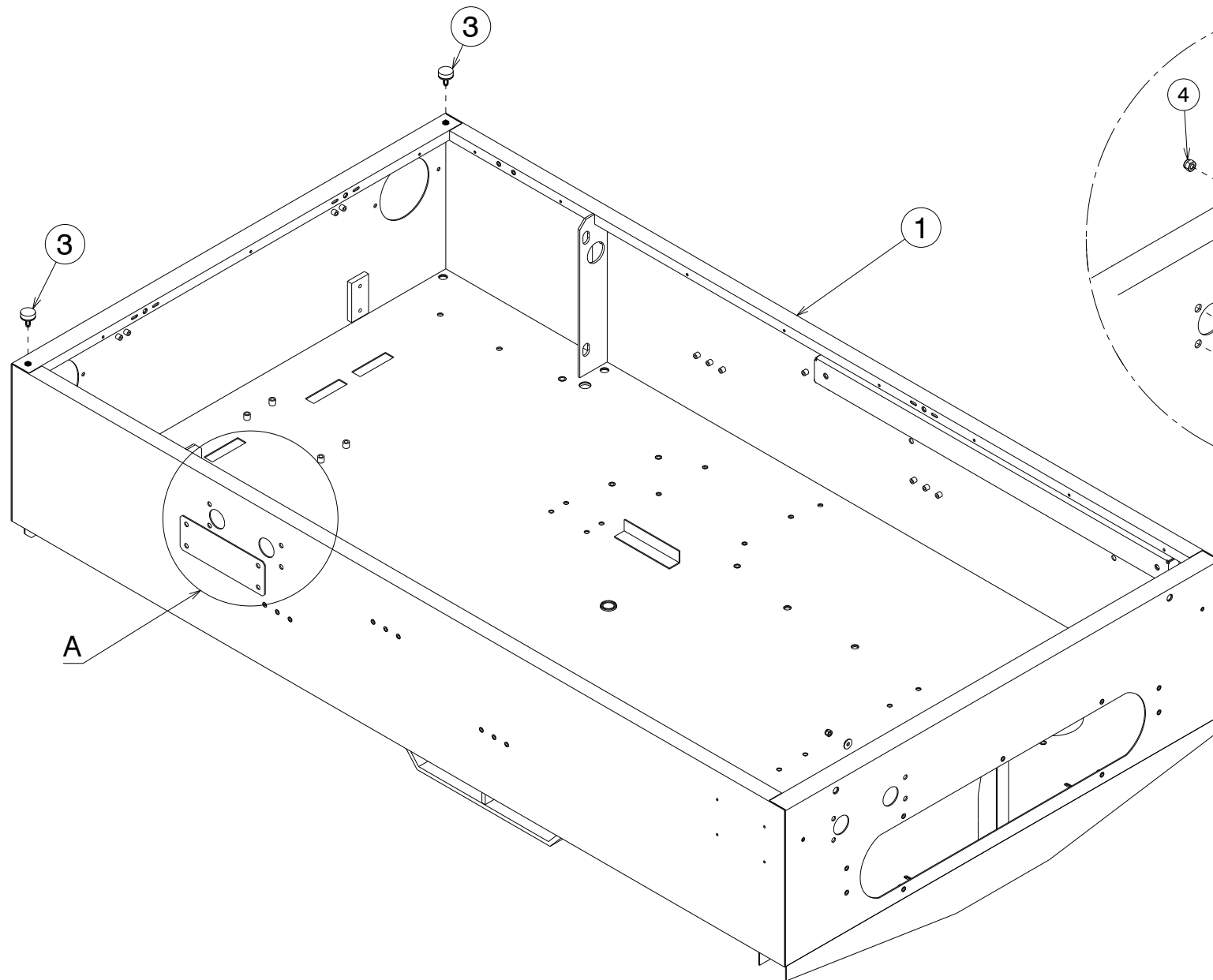

Detail A



## PARTS LIST

### Motocompressor – D185T4F

PARTS LEGENDA: Chassis

Tab. 01.1

REF	NAME	CODE	QUANTITY
1	Chassis	038-0525990-S	1
2	Closing panel	124-307899-S	1
3	Silent block	061-900-S	2
4	Hex nut M8 UNI 7473	137-040-S	4
5	Hex head screw . M8x20	132-10105-S	4
6	Washer d. 8x17x1,5	015-030-S	4

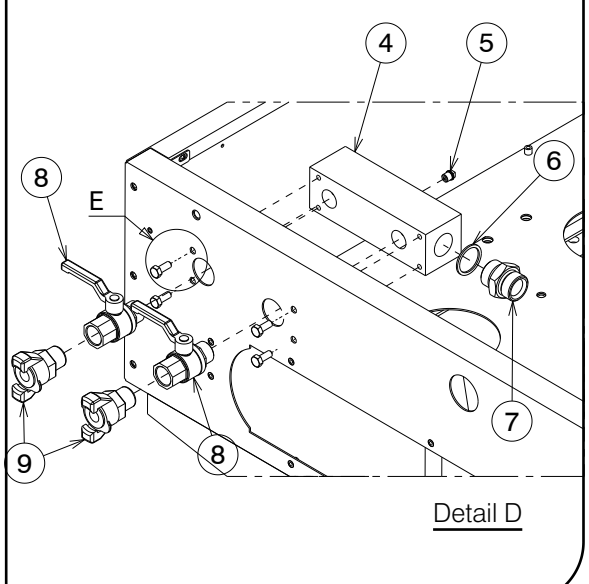
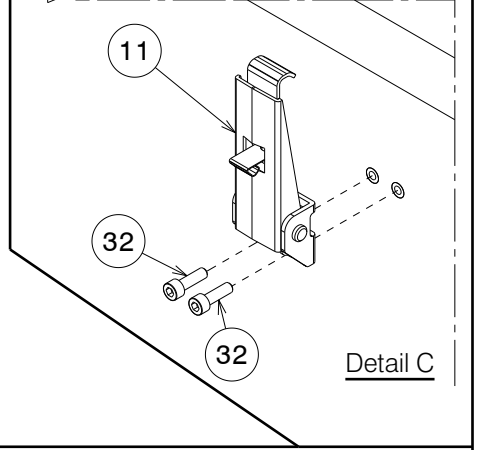
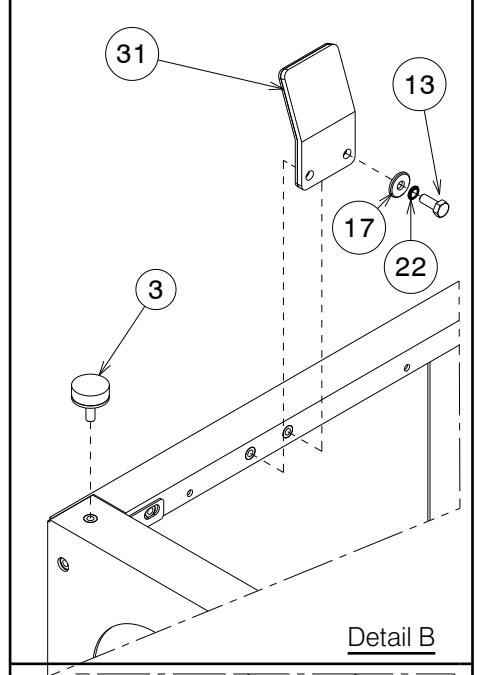
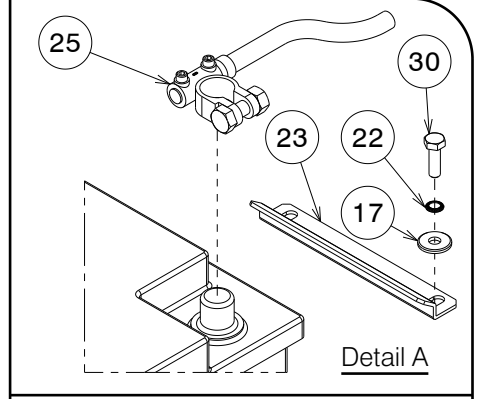
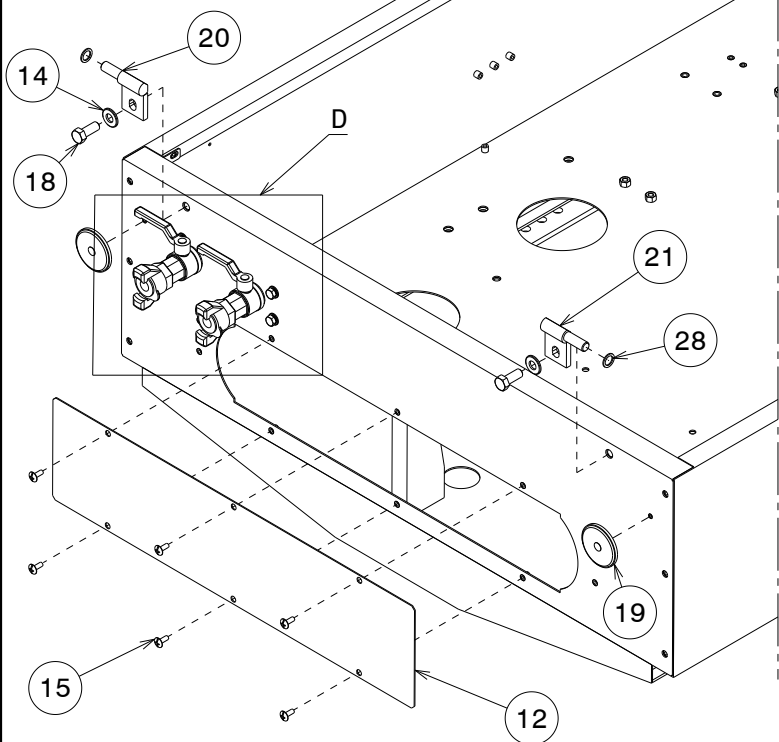
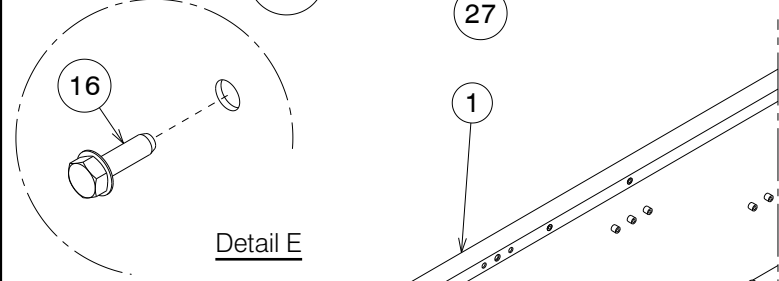
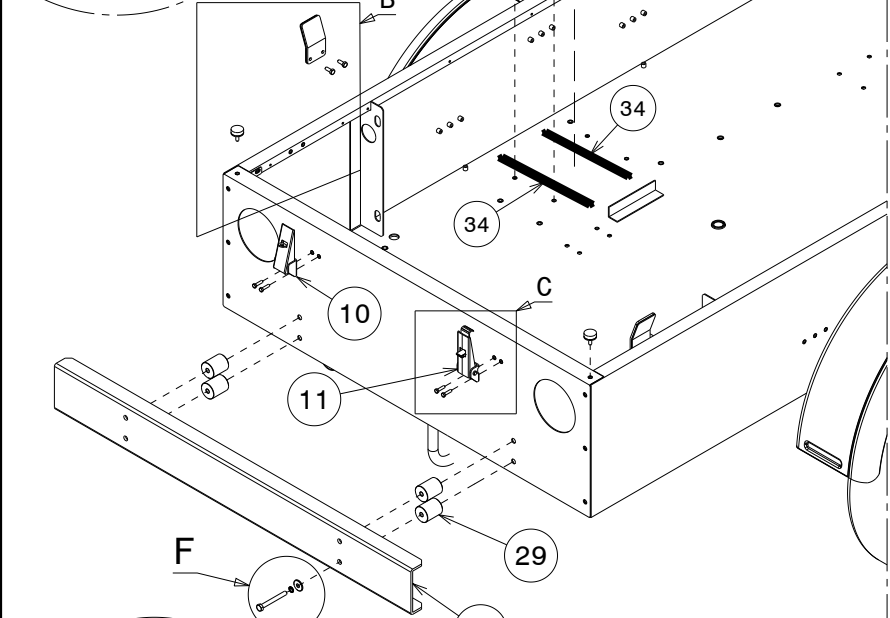
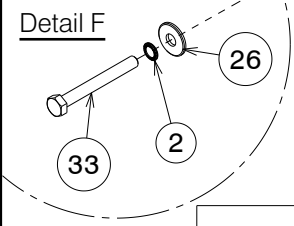
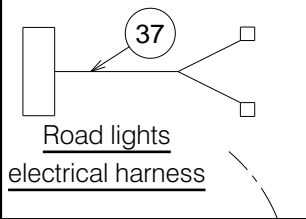



## PARTS LIST

### Motocompressor – D185T4F

PARTS LEGENDA: Chassis

Tab. 01.2

REF	NAME	CODE	QUANTITY
1	Chassis	038-0525990-S	1
2	Schnorr washer d.8	015-251-S	4
3	Silent block	061-900-S	2
4	Exit valves clamping sleeve	063-106700-S	1
5	Square head plug (1/8")	106-020-S	1
6	Copper washer 33,1x40x2	015-018-S	1
7	Double screw G 1"	187-070-S	1
8	Ball valve	152-030-S	2
9	Bayonet fitting	148-651-S	2
10	Lock with hole	128-0065-S	1
11	Lock without hole	128-006-S	1
12	Front closing panel	124-291-S	1
13	Hexagonal head Screw M6x16 UNI 5739	132-062-S	4
14	Flat washer D.13x27x2,5	015-047-S	2
15	Large head screw M6x16	243-009-S	6
16	Flanged hex head screw	132-10105-S	4
17	Flat washer d.6	015-029-S	8
18	Hexagonal head screw M.12x30 UNI 5739	132-192-S	2
19	White reflector d.60	147-071-S	2
20	Fixed right hinge	007-022-S	1
21	Fixed left hinge	007-023-S	1
22	Schnorr washer d.6	015-250-S	8
23	Battery clamp	115-009-S	2
24	Positive battery cable	252-054-S	1
25	Negative battery cable	252-055-S	1
26	Flat washer 8x24x2 UNI6593	015-031-S	4
27	Bumper	032-11763-S	1
28	Copper washer D.14x20x1,5	015-008-S	2
29	Bumper spacer	009-3123-S	4
30	Hex head screw . M6x20	132-063-S	4
31	Centering blade	120-039522-S	2
32	Hex socket head cap screw M6x20	133-092-S	4
33	Hexagonal head screw M8x70 UNI 5739	132-111-S	4
REF	NAME	CODE	LENGTH
34	Adhesive gasket 20X5	023-351-S	12"
			12"

Detail A

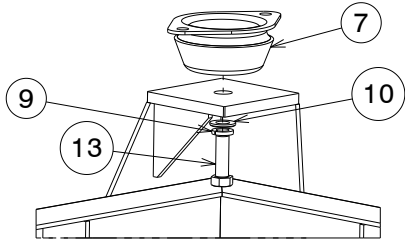

Detail C

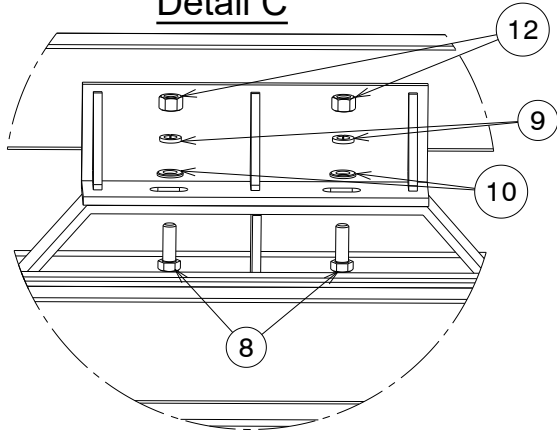

Detail B

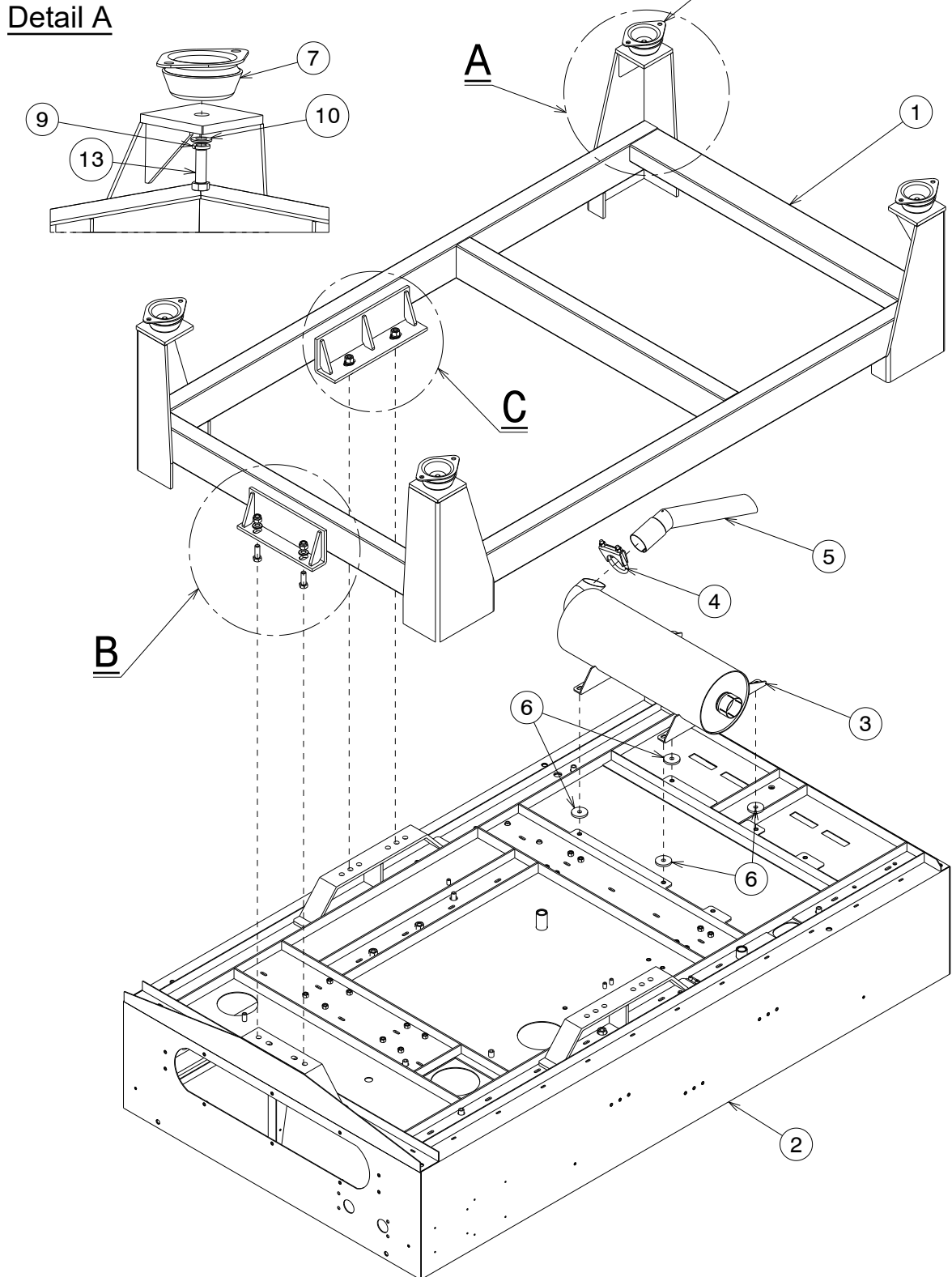
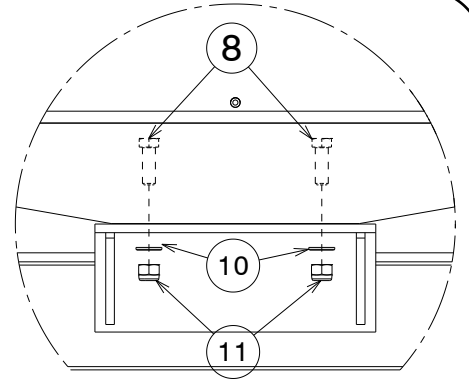



## PARTS LIST

### Motocompressor – D185T4F

**PARTS LEGENDA:** Skid subframe

Tab. 01.3

POSITION	DESCRIPTION	PART No.	QUANTITY
1	Skid subframe	038-052601020-S	1
2	Hexagonal head M12x40 screw	132-194-S	4
3	Muffler	042-087801-S	1
4	Pipes clamp d.54x8	149-070-S	1
5	Muffler extension (Skid version)	119-049560-S	1
6	Seal for muffler d.40 th..5	023-077-S	4
7	Silent Block	061-0065-S	4
8	Hexagonal head screw	132-193-S	6
9	Elastic washers	139-060-S	8
10	Flat washer d.13	015-034-S	10
11	Self-locking nut M12	137-060-S	2
12	Hex nut M12 UNI 5587	135-060-S	4

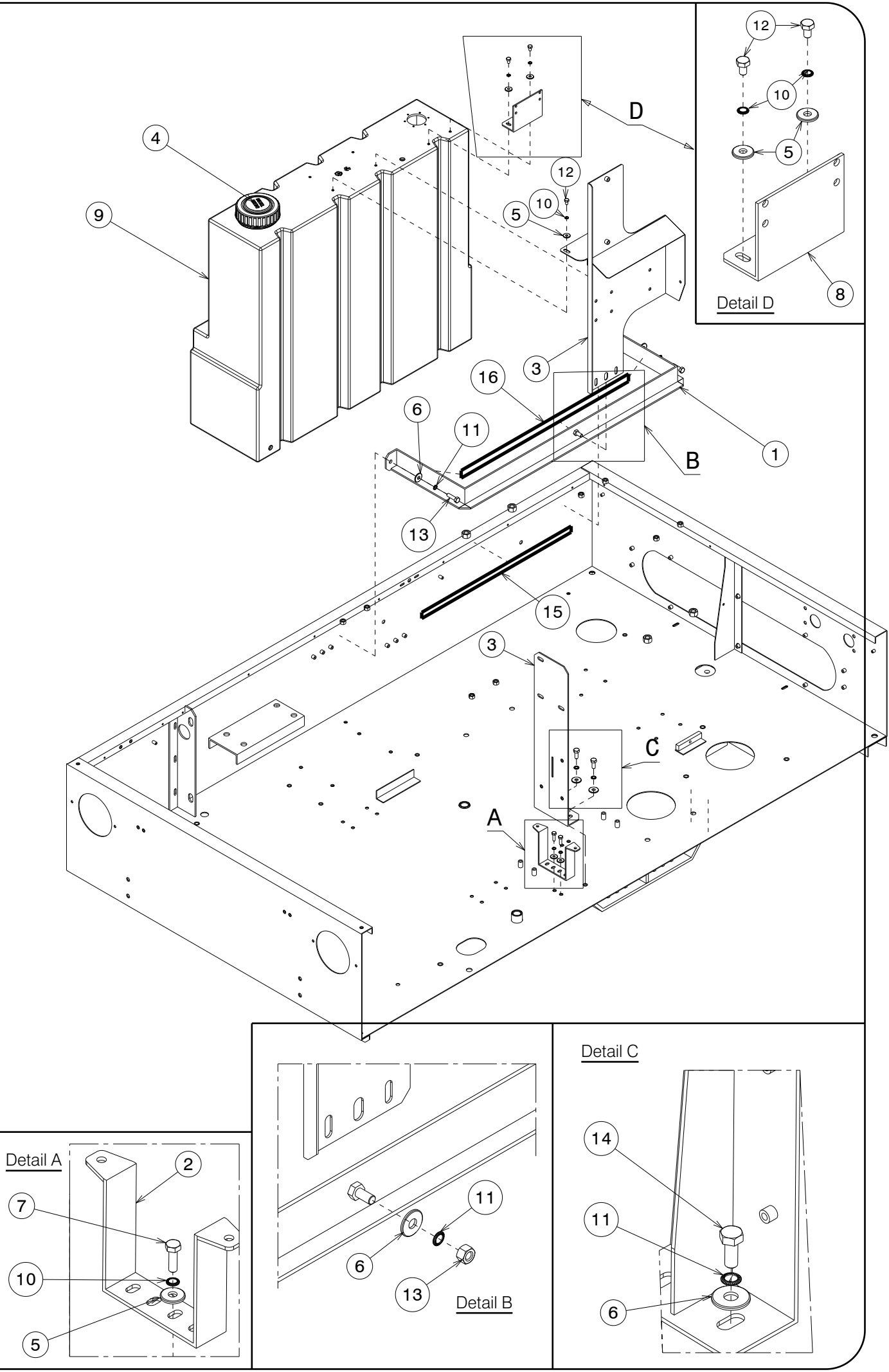



## PARTS LIST

### Motocompressor – D185T4F

**PARTS LEGENDA:** Clampings to the chassis

Tab. 01.4

REF	NAME	CODE	QUANTITY
1	Gasoil tank clamping blade	120-35032-S	1
2	Fuses box support blade	120-21977-S	1
3	Control panel support	010-315903-S	1
4	Tank cap	193-0420-S	1
5	Flat washer 6,6X18X2	015-029-S	6
6	Flat washer 8x24x2 UNI6593	015-031-S	6
7	Screw T.E. M6x20	132-063-S	2
8	Valves block support blade	010-3159047-S	1
9	Polyethylene gasoil tank	201-02370-S	1
10	Schnorr washer d.6	015-250-S	6
11	Schnorr washer d.8	015-251-S	5
12	Hex head screw M 6x10	132-060-S	4
13	Hex head screw M8x30	132-103-S	2
14	Hex head screw M8x20 UNI 5739	132-101-S	2
REF	NAME	CODE	LENGTH
15	Adhesive gasket 20X5	023-351-S	30"
16			47"

Detail A

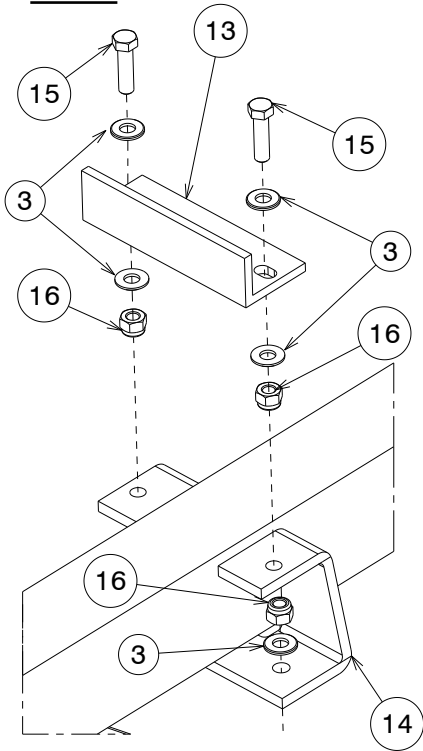

Detail B

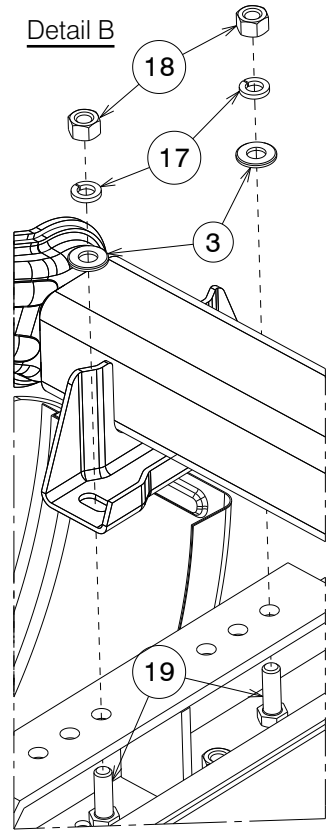

Detail D

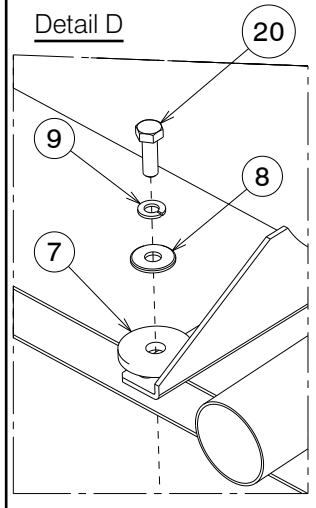

Detail C

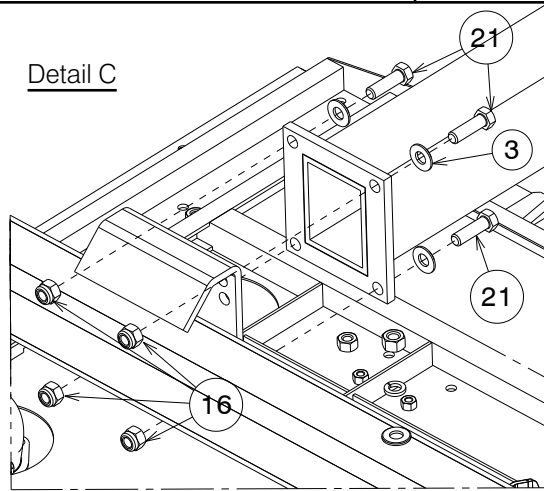

Detail E

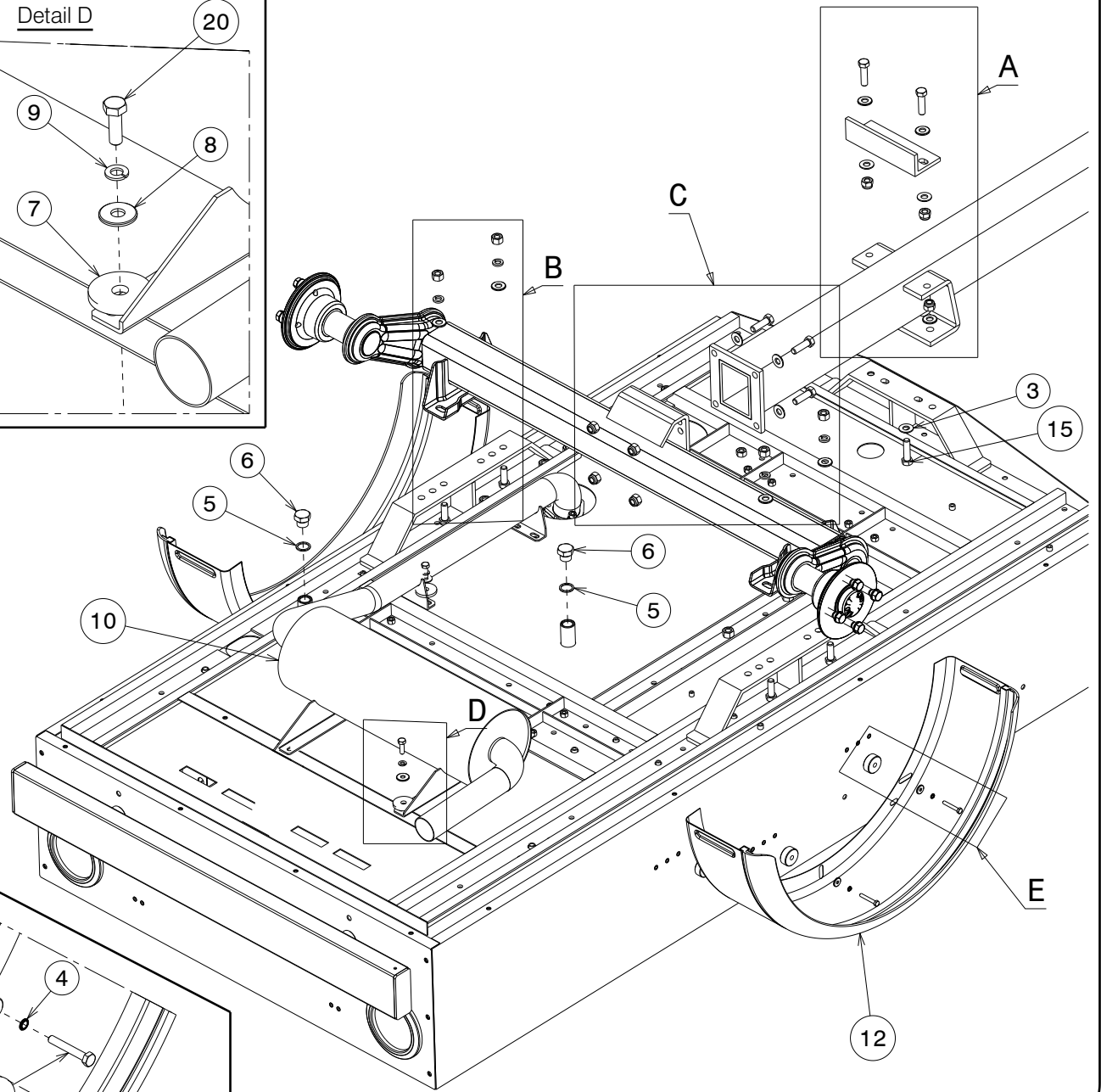
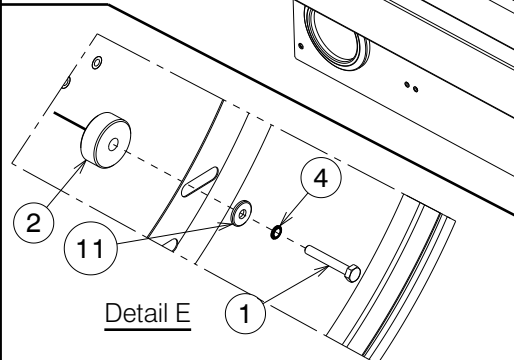



## PARTS LIST

### Motocompressor – D185T4F

PARTS LEGENDA: Clampings to chassis

Tab. 01.5

REF	NAME	CODE	QUANTITY
1	Hex head screw M6x40 UNI 5739	132-068-S	6
2	Mudguards spacers	009-312-S	6
3	Flat washer 13x27x2,5	015-047-S	16
4	Schnorr washer d.6	015-250-S	6
5	Copper washer (1/2")	015-0121-S	2
6	Iron plug ( 1/2")	106-125-S	2
7	Seal for muffler d.40 th..5	023-077-S	4
8	Flat washer 8x24x2 UNI6593	015-031-S	4
9	Elastic washer d.8	139-040-S	4
10	Muffler	042-087801-S	1
11	Washer d. 6.6x18x2	015-029-S	6
12	Mudguards	055-0154-S	2
13	Upper axle clamping section	120-39648101-S	1
14	Lower axle clamping section	120-39648121-S	1
15	Hex head screw M12x45 UNI 5739	132-195-S	4
16	Self-locking nut M12	137-060-S	8
17	Elastic washer d.12	139-060-S	4
18	Hex nut M12 UNI 5587	135-060-S	4
19	Hex head screw M12x35 UNI 5739	132-193-S	4
20	Hex head screw M8x25 UNI 5739	132-102-S	4
21	Hex head screw M12x40 UNI 5739	132-194-S	4





## PARTS LIST

### Motocompressor – D185T4F

PARTS LEGENDA: Fan cover – Radiator

Tab. 02

REF	NAME	CODE	QUANTITY
1	Fan cover	001-175840-S	1
2	Fan cover panel	124-28520-S	1
3	Radiator support	049-115535-S	1
4	Water-oil radiator	011-10430-S	1
5	Hex nut M8 UNI 7473	137-040-S	6
6	Gasoil filter	511-21-0002	1
7	Compensation tank	201-018505-S	1
8	Fitting ( 1/4" ) M for pipe d.8	148-198.2-S	1
9	Upper grid	124-307910-S	1
10	Left side grid	124-307912-S	1
11	Right side grid	124-307914-S	1
12	Diaphragm fairlead	239-016-S	1
13	90° fitting M + F (1/4")	148-143-S	1
14	Flat washer 8x24x2 UNI6593	015-031-S	14
15	Hexagonal head screw M8x30 UNI 5739	132-104-S	4
16	Hex head screw M8x20 UNI 5739	132-101-S	4
17	Self locking nut M8 UNI 7473	137-040-S	4
18	Hex head screw M6x20	132-063-S	9
19	Washer d.6	015-250-S	21
20	Flat washer 6x24x2 UNI6593	015-038-S	11
21	Schnorr washer d.8	015-251-S	8
22	Hex head screw M10x25 UNI 5739	132-142-S	2
23	Schnorr washer d.10	015-252-S	2
24	Flat washer 10,2x21x2	015-032-S	2
25	Hexagonal head Screw M6x16 UNI 5739	132-062-S	10
26	Washer d. 6.6x18x2	015-029-S	8
27	Fairlead	239-040-S	1
28	Hex head screw M8x25 UNI 5739	132-102-S	6
29	Fan protection grid support blade	120-3964816-S	1
30	Clamp	149-237-S	2
31	Cable fastener clamp	149-220-S	2
32	Flanged hex head screw 6x20	132-10105-S	4
33	Spacer	009-2320-S	4
REF	NAME	CODE	LENGTH
34	Adhesive gasket 20X5	023-351-S	42"

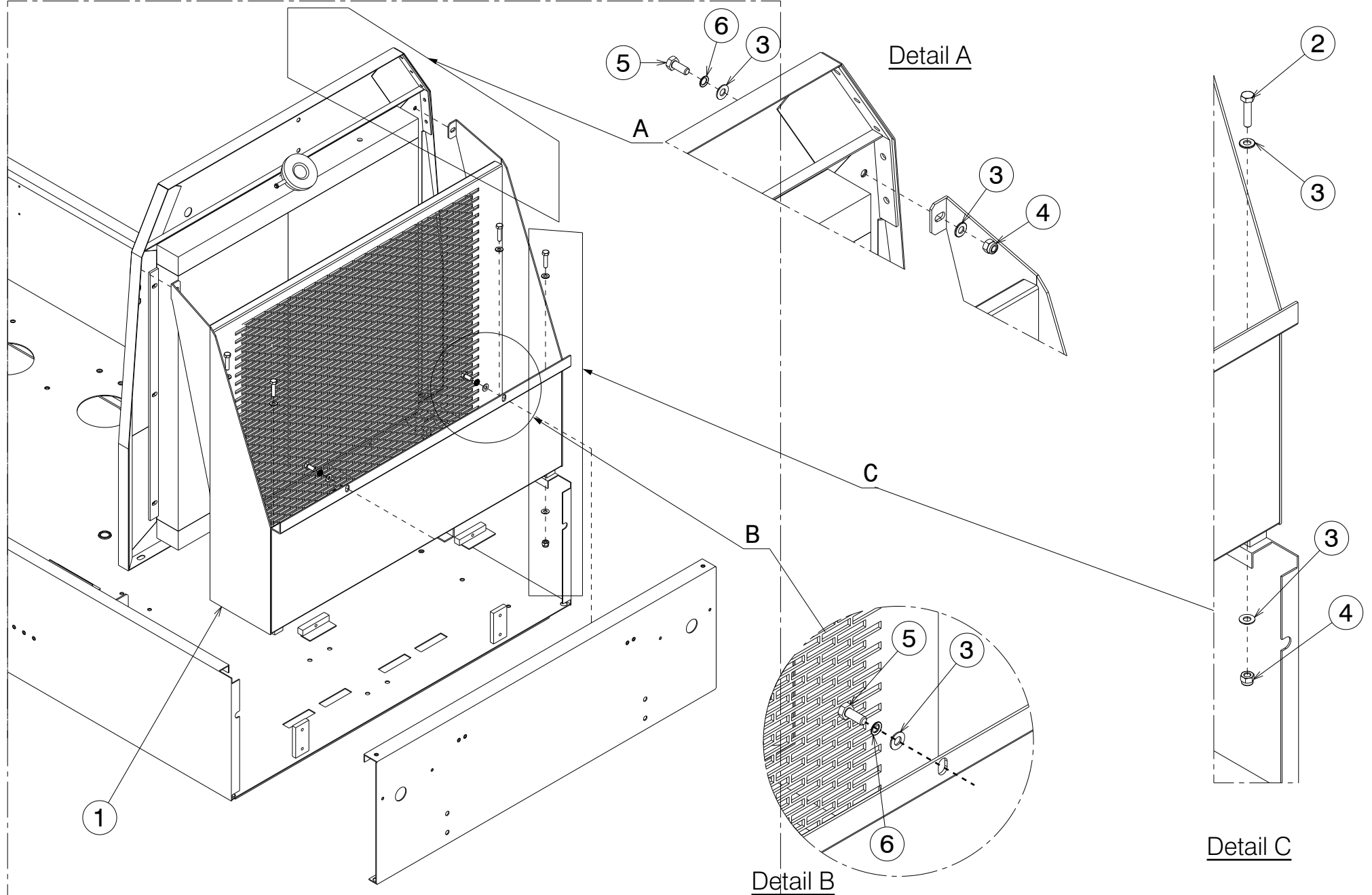



## PARTS LIST

### Motocompressor – D185T4F

PARTS LEGENDA: Toolbox

Tab. 02.1

REF	NAME	CODE	QUANTITY
1	Toolbox (Up to Serial No.C39008)	029-04951-S	1
	Toolbox (From Serial No.C40726)	029-049511-S	1
2	Hexagonal head screw M8x40	132-105-S	4
3	Washer 8x17	015-030-S	14
4	Self-locking Nut M8	137-040-S	6
5	Hexagonal head screw M8x20	132-101-S	4
6	Schnorr washer d.8	015-251-S	2

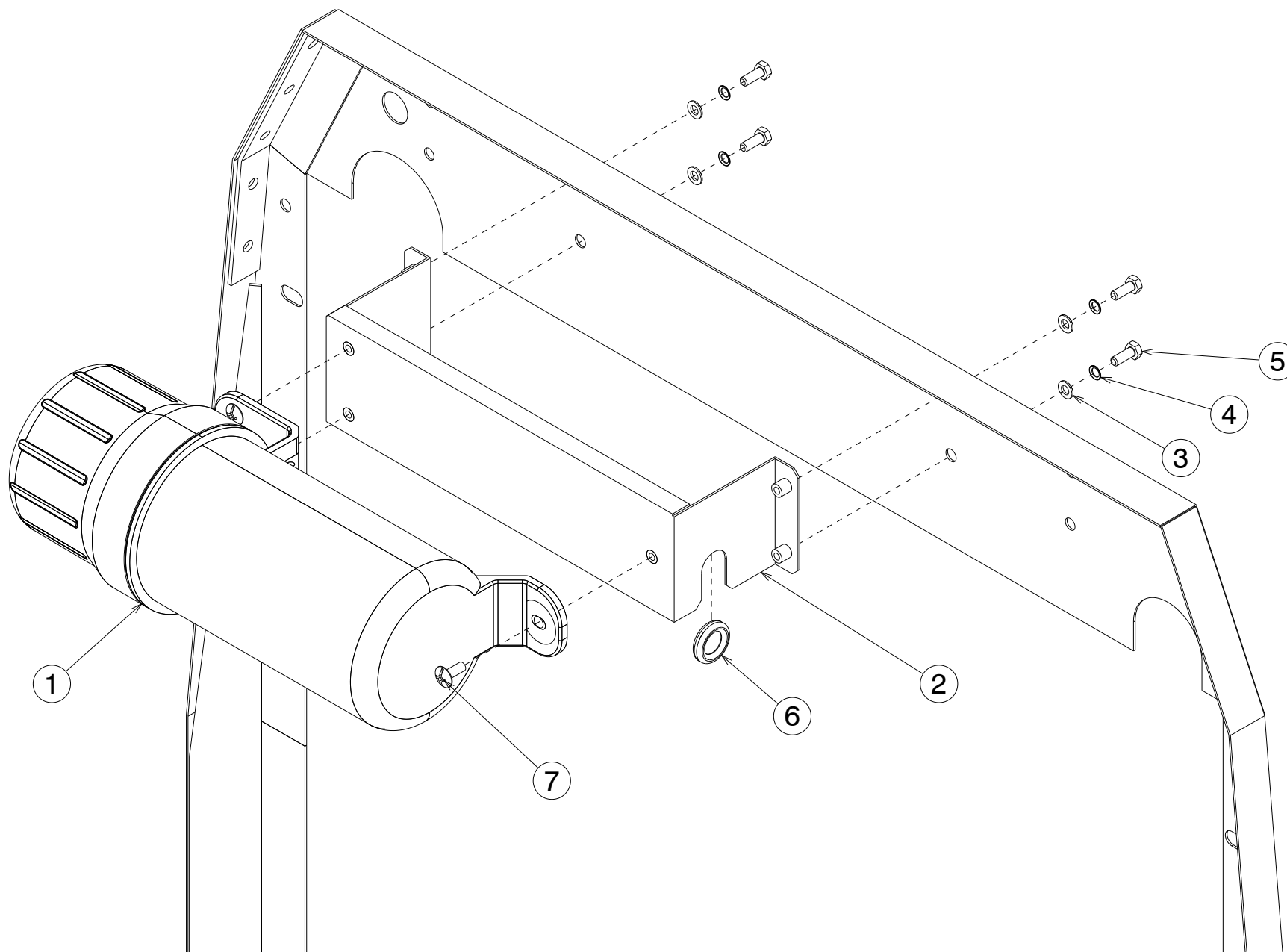



## PARTS LIST

### Motocompressor – D185T4F

**PARTS LEGENDA:** Document holder

Tab. 02.2

REF	NAME	CODE	QUANTITY
1	Document holder box	029-3010-S	1
2	Document holder box support	010-3159156-S	1
3	Flat washer 6,6x12x1,5 DIN125/1	015-027-S	4
4	Washer d.6	015-250-S	4
5	Hex head screw M6x16	132-062-S	4
6	Fairlead	239-016-S	2
7	Large head screw M6x16	243-009-S	3

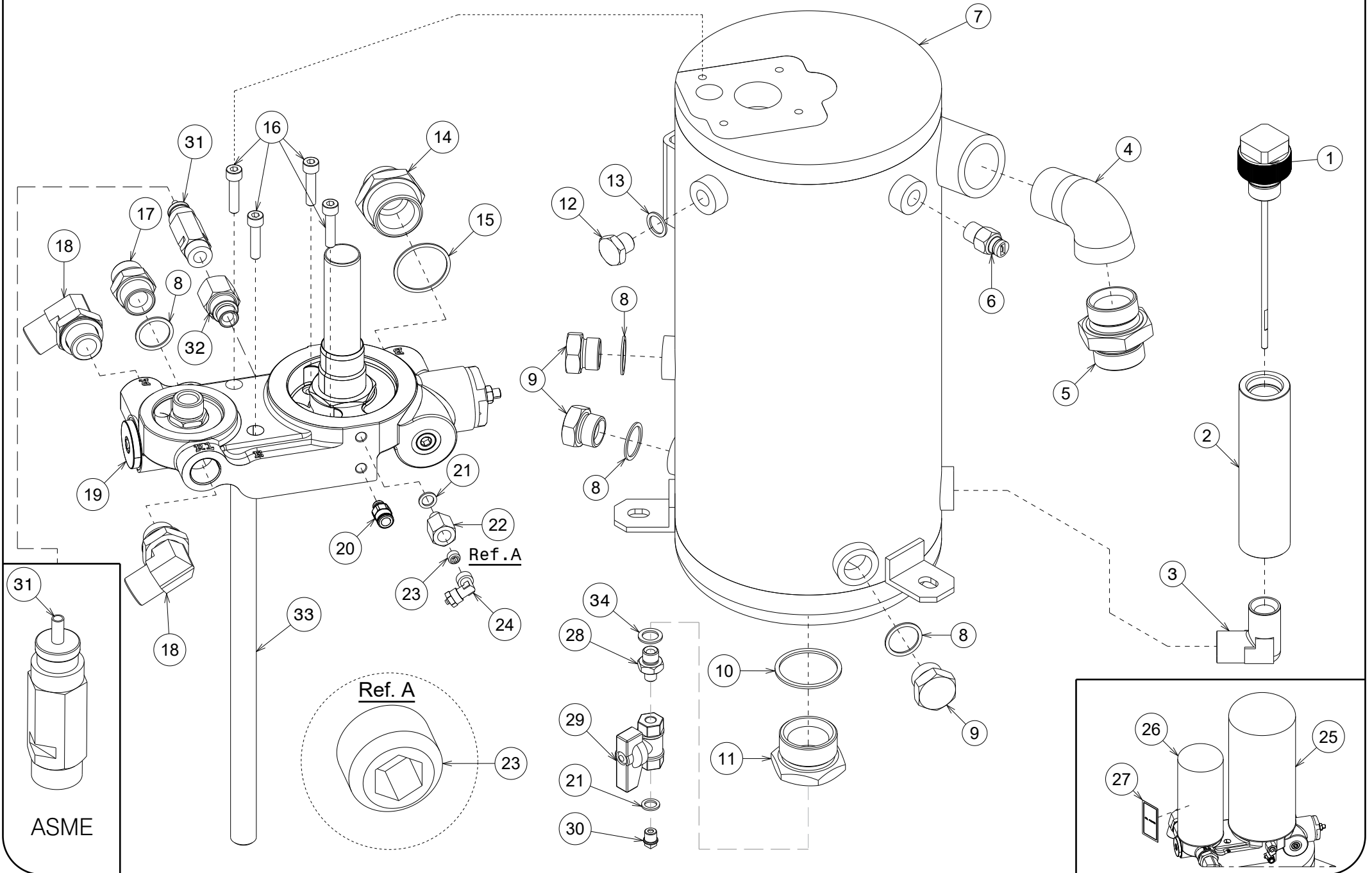



## PARTS LIST

### Motocompressor – D185T4F

PARTS LEGENDA: Separator tank

Tab. 03

REF	NAME	CODE	QUANTITY
1	Oil level dipstick	106-01060-S	1
2	Oil sleeve	063-1205-S	1
3	Conical 90° M+M adapter coupling ( 3/4" )	148-287.35-S	1
4	Short radius curve M+F ( 1 1/4" )	111-060-S	1
5	Double screw ( 1 1/4" )	187-0852-S	1
6	Compressor thermal contact 115'	103-008-S	1
7	ASME Separator tank (20 lt – 5.30 gal)	037-056825-S	1
8	Copper washer ( 3/4" )	015-015-S	4
9	Male hexagonal head iron plug ( 3/4" )	106-130-S	3
10	Copper washer ( 1 1/2" )	015-019.1-S	1
11	Reduction M 1 1/2 - F 1/4"	190-0845-S	1
12	Male hexagonal head iron plug ( M16x1.5 )	106-100-S	1
13	Copper washer ( d. 16.2x22x1.5 )	015-009-S	1
14	Double screw ( 1 – 1 1/4" )	187-075-S	1
15	Copper washer ( 1 1/4" )	015-019-S	1
16	Hex socket head cap screw ( M8x35 )	133-135-S	4
17	Double screw ( 3/4" )	187-060-S	1
18	90° fitting M+M ( 3/4" )	148-2985-S	2
19	Valve assembly	024-021530-F	1
20	Straight quick coupling ( 1/8" ) for pipe d.8	148-577-S	1
21	Copper washer ( 1/8" )	015-005-S	2
22	Extension F+M L=30 ( 1/4" – 1/8" )	189-302-S	1
23	Grub screw with conical hexagon ( 1/8" )	218-0012-S	1
24	Elbow fitting ( 1/4" ) for pipe d.6	148-090-S	1
25	Separator filter	157-171-S	1
26	Compressor oil filter P<10 bar	099-008-S	1
27	Oil filter sticker	238-002-S	1
28	Double screw 1/4 - 1/8	187-002-S	1
29	Ball valve (1/8")	152-005-S	1
30	Square head plug (1/8")	106-020-S	1
31	Safety valve (ASME)	033-059-S	1
32	Reduction 1/2F to 3/8M l=33	190-1512-S	1
33	Draft pipe	064-1030-S	1
34	Copper washer 1/4"	015-007-S	1

Detail C

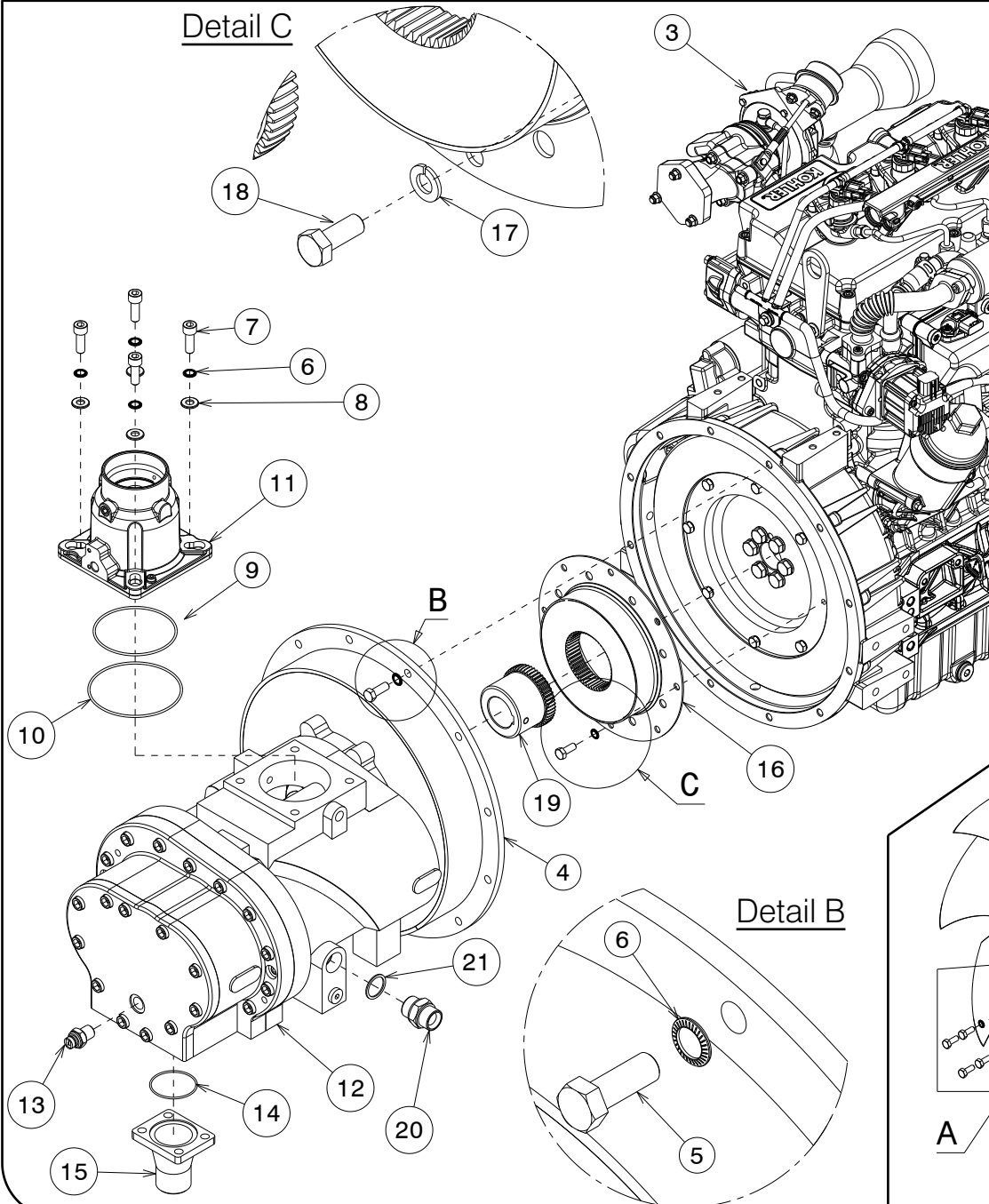

Detail A

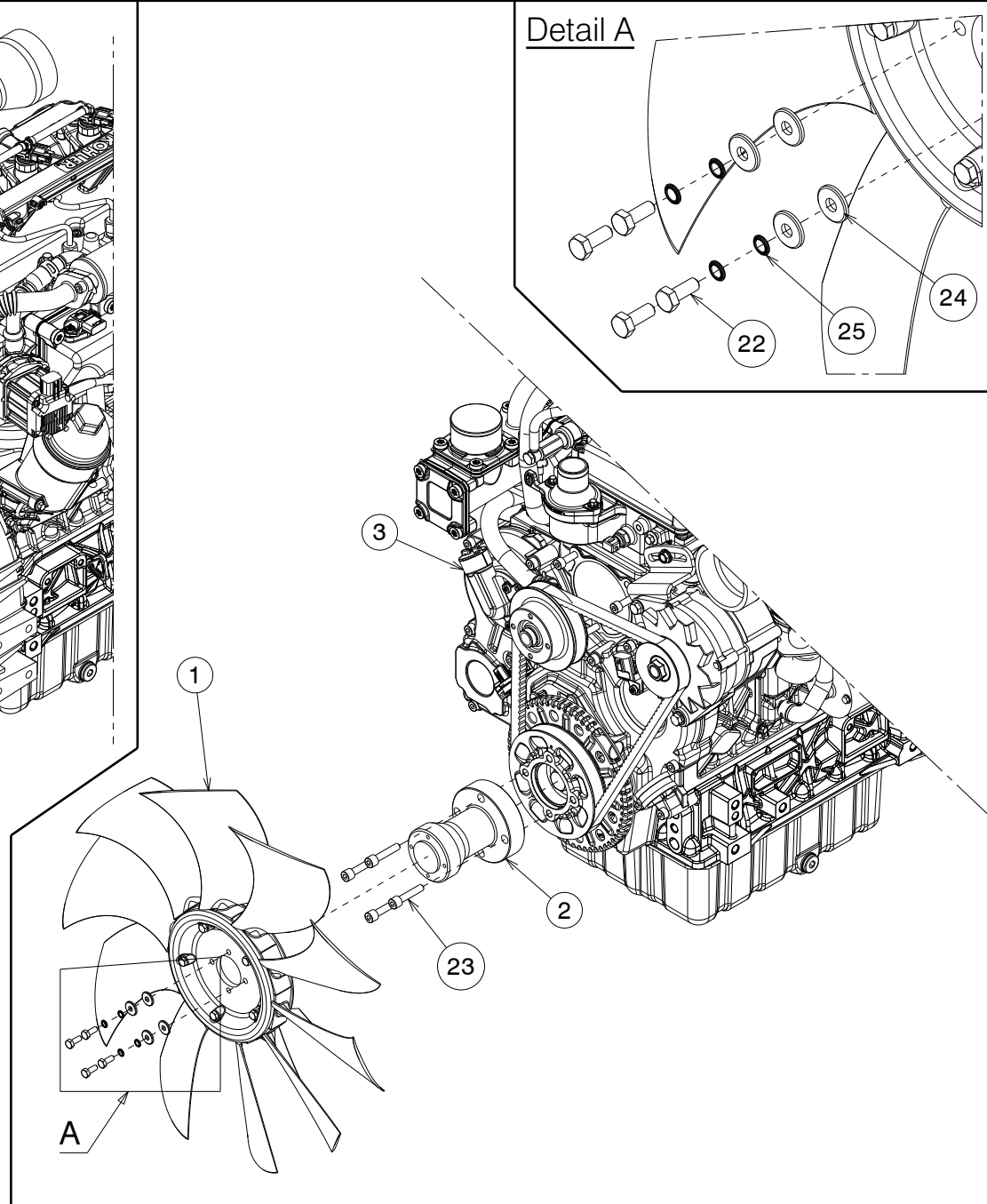



## PARTS LIST

### Motocompressor – D185T4F

**PARTS LEGENDA:** Engine – Air end

Tab. 04.1

REF	NAME	CODE	QUANTITY
1	Fan (From Serial No.C40401)	083-14133-S	1
2	Fan support (From Serial No.C40401)	028-08351-S	1
	Fan support (Up to Serial No.C40400)	028-0835-S	1
3	Engine	165-42492-S	1
4	Fly wheel housing	020-089310-S	1
5	Hexagonal head screw 3/8-16 UNC L=1	132-701-S	12
6	Schnorr washer d.10	015-252-S	16
7	Hex socket head cap screw M10 x 30	133-183-S	4
8	Plane washer	015-032-S	4
9	OR seal 3375	023-3035-S	1
10	OR seal 3425	023-2885-S	1
11	Inlet valve	024-138181-F	1
12	Air end	024-032914614-F	1
13	Thermal contact	103-0125-S	1
14	OR seal 3206	023-067-S	1
15	Flex clamping flange	004-0695-S	1
16	KTR Engine joint	006-10800-S	1
17	Grover washer d.8	139-040-S	4
18	Hexagonal head screw 5/16-18 UNC L=20mm	132-70180-S	8
19	KTR air end joint	006-10802-S	1
20	Double screw ¾ hole 19,1 Din standard	187-060-S	1
21	Copper washer ( ¾" )	015-015-S	1
22	Hexagonal head Screw M6x20 UNI 5739	132-063-S	4
23	Hex socket head cap screw M10x 40	133-137-S	4
24	Washer d. 6.6x18x2	015-029-S	4
25	Schnorr washer d.6	015-250-S	4

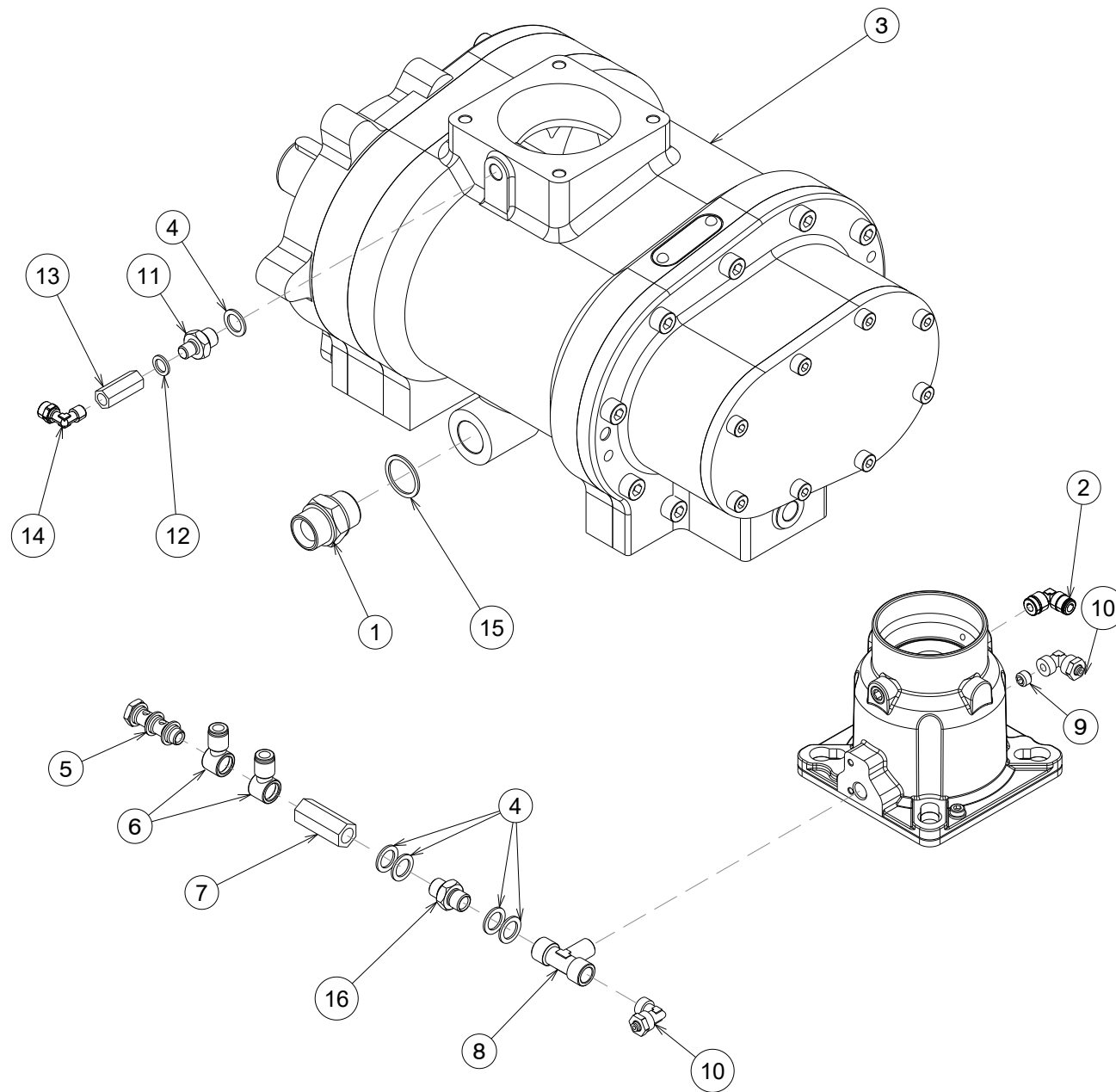



## PARTS LIST

### Motocompressor – D185T4F

**PARTS LEGENDA:** Pneumatic Regulation system

Tab. 04.2

REF	NAME	CODE	QUANTITY
1	Double screw G 3/4"	187-060-S	1
2	Quick coupling 90° ( 1/4" ) for pipe d.8	148-573.5-S	1
3	Air end assembly	024-032914614-F	1
4	Copper washer ( 1/4" )	015-007-S	5
5	Quick coupling ( 1/4" )	148-59005-S	1
6	Quick coupling ( 1/4" )	148-5901-S	2
7	Check valve ( 1/4" )	033-017-S	1
8	T fitting F+M+F ( 1/4" )	148-194-S	1
9	Grub screw with hexagon ( 1/8" )	218-001-S	1
10	90° fitting (1/4") for pipe d. 8	148-110-S	2
11	Double screw ( 1/4" – 1/8" )	187-002-S	1
12	Copper washer ( 1/8" )	015-005-S	2
13	Check valve ( 1/8" )	033-001-S	1
14	90° fitting ( 1/8" ) for pipe d.6	148-080-S	1
15	Copper washer	015-015-S	1
16	Double screw 1/4"	187-005-S	1





# PARTS LIST

## Motocompressor – D185T4F

**PARTS LEGENDA:** Pneumatic Regulation system

Tab. 04.2.1

REF	NAME	CODE	QUANTITY
<b>A - From Serial No.C45352</b>			
1	Devices coupling block	053-300-S	1
2	Quick coupling 90° ( 1/4" ) for pipe d.8	148-573.5-S	1
3	90° quick coupling ( 1/8" ) for pipe d.6	148-570-S	1
4	Flat washer 6,6x12x1,5 DIN125/1	015-027-S	4
5	Hex socket head cap screw M12x12	133-2285-S	1
6	Hexagonal head Screw M6x16 UNI 5739	132-062-S	4
7	Straight quick coupling ( 1/4" ) for pipe d.8	148-575-S	1
8	Straight quick coupling ( 1/8" )	148-8001-S	1
9	Max pressure valve assembly(Up to S/N C37341)	024-032.1-F	1
	Max pressure valve assembly(From S/N C38470)	024-0323-F	1
10	Spacer D. 1/8"	009-014-S	1
11	Quick coupling 90° ( 1/8" ) for pipe d.8	148-572-S	1
12	Copper washer int. d. 12.2	015-006-S	2
13	Built-in hexagonal head plug M12x1.5	106-092-S	1
14	Solenoid valve (From S/N C41475)	160-052-S	1
15	Washer d.6	015-250-S	4
16	Pressure transducer	205-030-S	1
17	Copper washer ( 1/8" )	015-005-S	1
21	Copper washer ( 1/4" )	015-007-S	1
<b>B - From Serial No.C44866 up to C45351</b>			
REF	NAME	CODE	QUANTITY
1	Devices coupling block	053-300-S	1
2	Quick coupling 90° ( 1/4" ) for pipe d.8	148-573.5-S	1
4	Flat washer 6,6x12x1,5 DIN125/1	015-027-S	4
5	Hex socket head cap screw M12x12	133-2285-S	1
6	Hexagonal head Screw M6x16 UNI 5739	132-062-S	4
7	Straight quick coupling ( 1/4" ) for pipe d.8	148-575-S	1
8	Straight quick coupling ( 1/8" )	148-8001-S	1
9	Max pressure valve assembly(Up to S/N C37341)	024-032.1-F	1
	Max pressure valve assembly(From S/N C38470)	024-0323-F	1
10	Spacer D. 1/8"	009-014-S	1
11	Quick coupling 90° ( 1/8" ) for pipe d.8	148-572-S	1
12	Copper washer int. d. 12.2	015-006-S	2
13	Built-in hexagonal head plug M12x1.5	106-092-S	1
14	Solenoid valve (From S/N C41475)	160-052-S	1
15	Washer d.6	015-250-S	4
17	Copper washer ( 1/8" )	015-005-S	1
18	Square head plug (1/8")	106-020-S	1
19	Straight quick coupling ( 1/4" ) for pipe d.6	148-574-S	1
31	Copper washer int. d. 12.2	015-006-S	1
34	Straight quick coupling ( 1/4" ) for pipe d.6	148-574-S	1



# PARTS LIST

## Motocompressor – D185T4F

**PARTS LEGENDA:** Pneumatic Regulation system

Tab. 04.2.1

<u>C - From Serial No.C41475 up to C44865</u>			
REF	NAME	CODE	QUANTITY
1	Devices coupling block	053-300-S	1
2	Quick coupling 90° ( 1/4" ) for pipe d.8	148-573.5-S	1
7	Straight quick coupling ( 1/4" ) for pipe d.8	148-575-S	1
8	Straight quick coupling ( 1/8" )	148-8001-S	1
9	Max pressure valve assembly (Up to S/N C37341)	024-032.1-F	1
	Max pressure valve assembly (From S/N C38470)	024-0323-F	1
10	Spacer D. 1/8"	009-014-S	1
11	Quick coupling 90° ( 1/8" ) for pipe d.8	148-572-S	1
12	Copper washer int. d.12.2	015-006-S	1
13	Built-in hexagonal head plug M12x1.5	106-092-S	1
14	Solenoid valve (From S/N C41475)	160-052-S	1
17	Copper washer ( 1/8" )	015-005-S	1
19	Straight quick coupling ( 1/4" ) for pipe d.6	148-574-S	1
31	Copper washer int. d. 12.2	015-006-S	1
<u>D - From Serial No.C41090 up to C41474</u>			
REF	NAME	CODE	QUANTITY
1	Devices coupling block	053-300-S	1
2	Quick coupling 90° ( 1/4" ) for pipe d.8	148-573.5-S	2
7	Straight quick coupling ( 1/4" ) for pipe d.8	148-575-S	1
8	Straight quick coupling ( 1/8" )	148-8001-S	1
9	Max pressure valve assembly(Up to S/N C37341)	024-032.1-F	1
	Max pressure valve assembly(From S/N C38470)	024-0323-F	1
12	Copper washer int. d. 12.2	015-006-S	1
13	Built-in hexagonal head plug M12x1.5	106-092-S	1
14	Solenoid valve (Up to S/N C41474)	160-0871-S	1
20	Double screw G 1/4"	187-006-S	1
31	Copper washer int. d. 12.2	015-006-S	1
21	Copper washer ( 1/4" )	015-007-S	1
22	Oil pressure switch 1,4bar	154-030-S	1
23	Oil pressure switch 3,5bar	150-025-S	1
24	Oil pressure switch cap	284-020-S	1

This page has been intentionally left blank

From Serial No.C44866

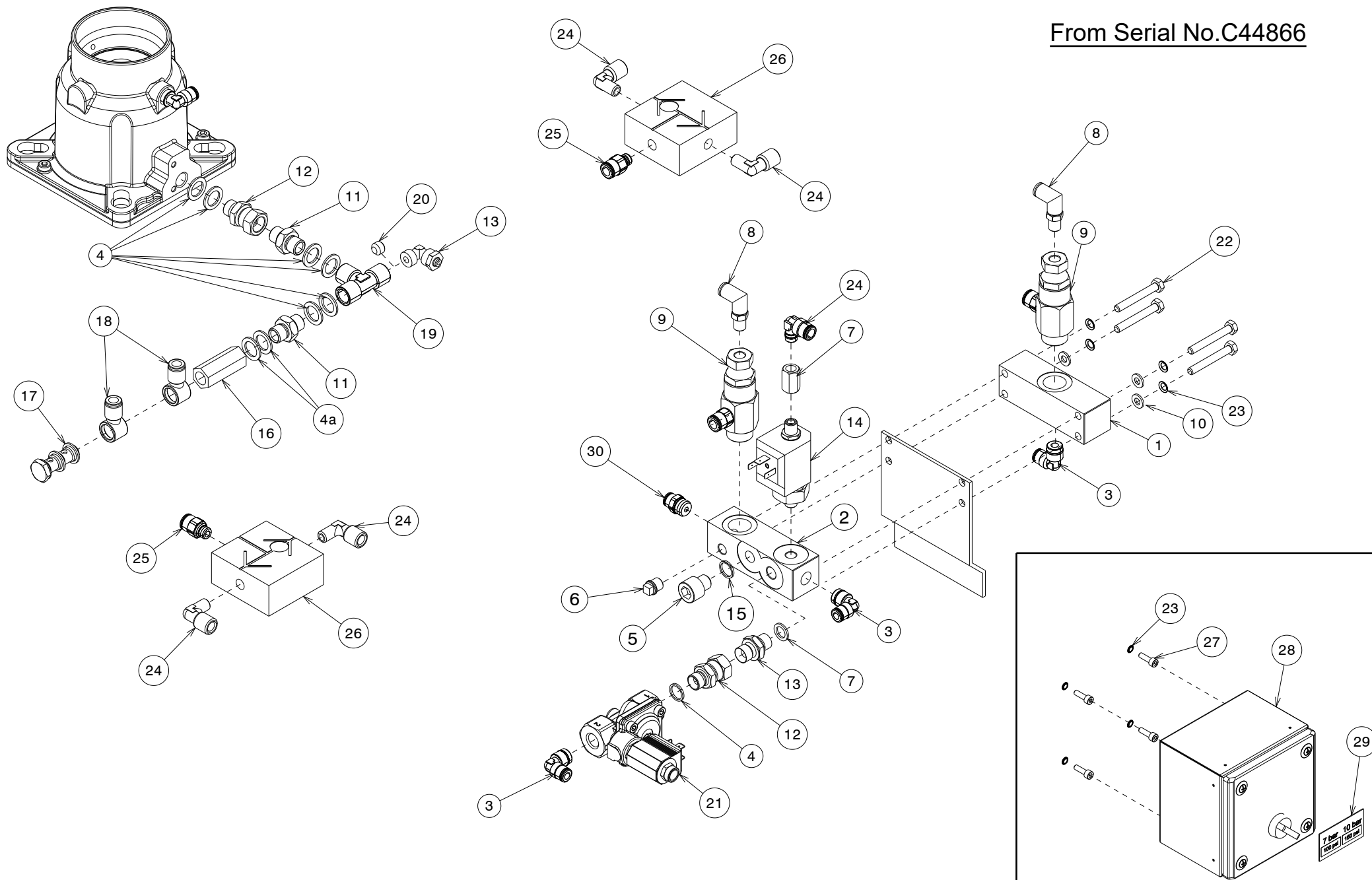



## PARTS LIST

### Motocompressor – D185T4F

**PARTS LEGENDA:** Pneumatic Regulation system  
Double pressure version

Tab. 04.3

REF	NAME	CODE	QUANTITY
2	Devices coupling block	053-300-S	1
3	Quick coupling 90° ( 1/4" ) for pipe d.8	148-573.5-S	1
4	Copper washer 1/4"	015-007-S	7
5	Hex socket head cap screw M12x12	133-2285-S	1
6	Square head plug (1/8")	106-020-S	1
7	Copper washer 1/8"	015-005-S	1
8	Straight quick coupling ( 1/8" )	148-8001-S	1
9	Max pressure valve assembly	024-0323-F	1
11	Double screw ( 1/4" )	187-005-S	2
12	Straight adapter coupling M+F rotating ( 1/4" )	148-003.2-S	1
13	90° fitting (1/4") for pipe d. 8	148-110-S	1
14	Solenoid valve	160-052-S	1
15	Copper washer int. d. 12.2	015-006-S	1
17	Quick coupling ( 1/4" )	148-59005-S	1
18	Super quick coupling ( 1/4" )	148-5901-S	2
19	T fitting F+F+F ( 1/4" )	148-142-S	1
20	Hex head screw with hexagon ( 1/8" )	218-0012-S	1
24	Quick coupling 90° ( 1/8" ) for pipe d.8	148-572-S	1
30	Straight fitting (1/4") for pipe d. 6	148-574-S	1
<b>DOUBLE PRESSURE CONVERSION KIT</b>			
REF	NAME	CODE	QUANTITY
1	Devices coupling block	053-3005-S	1
3	Quick coupling 90° ( 1/4" ) for pipe d.8	148-573.5-S	2
4	Copper washer 1/4"	015-007-S	1
4a	Copper washer 1/4"(replace in case of breakage during disassembly)	015-007-S	2
7	Copper washer 12x18x1,5 (replace in case of breakage during disassembly)	015-006-S	1
8	Straight quick coupling ( 1/8" )	148-8001-S	1
9	Pressure regulation valve assembly	024-0323-F	1
10	Plane washer 6x12	015-027-S	4
12	Straight adapter coupling M+F rotating ( 1/4" )	148-003.2-S	1
13	Double screw M12x1.5 – 1/4"	187-049-S	1
16	1/4" non-return valve (Replace 033-017-S standard version valve)	033-0178-S	1
21	Solenoid valve	160-0871-S	1
22	Hex head screw M6x45	132-069-S	4
23	Schnorr washer d.6	015-250-S	8
24	Quick coupling 90° ( 1/8" ) for pipe d.8	148-572-S	4
25	Straight quick coupling ( 1/8" ) per tubo d.8	148-577-S	2
26	Pneumatic valve OR	033-0850-S	2
27	Hex socket head cap screw M6x20	133-092-S	4
28	Electrical box and harness	269-5480-S	1
29	"Double pressure 7 – 10 bar" sticker	238-0465-S	1
--	Rylsan pipe d.8x6	089-0705-S	L = 6,50 ft

Replace 033-017-S non return valves with 033-0178-S

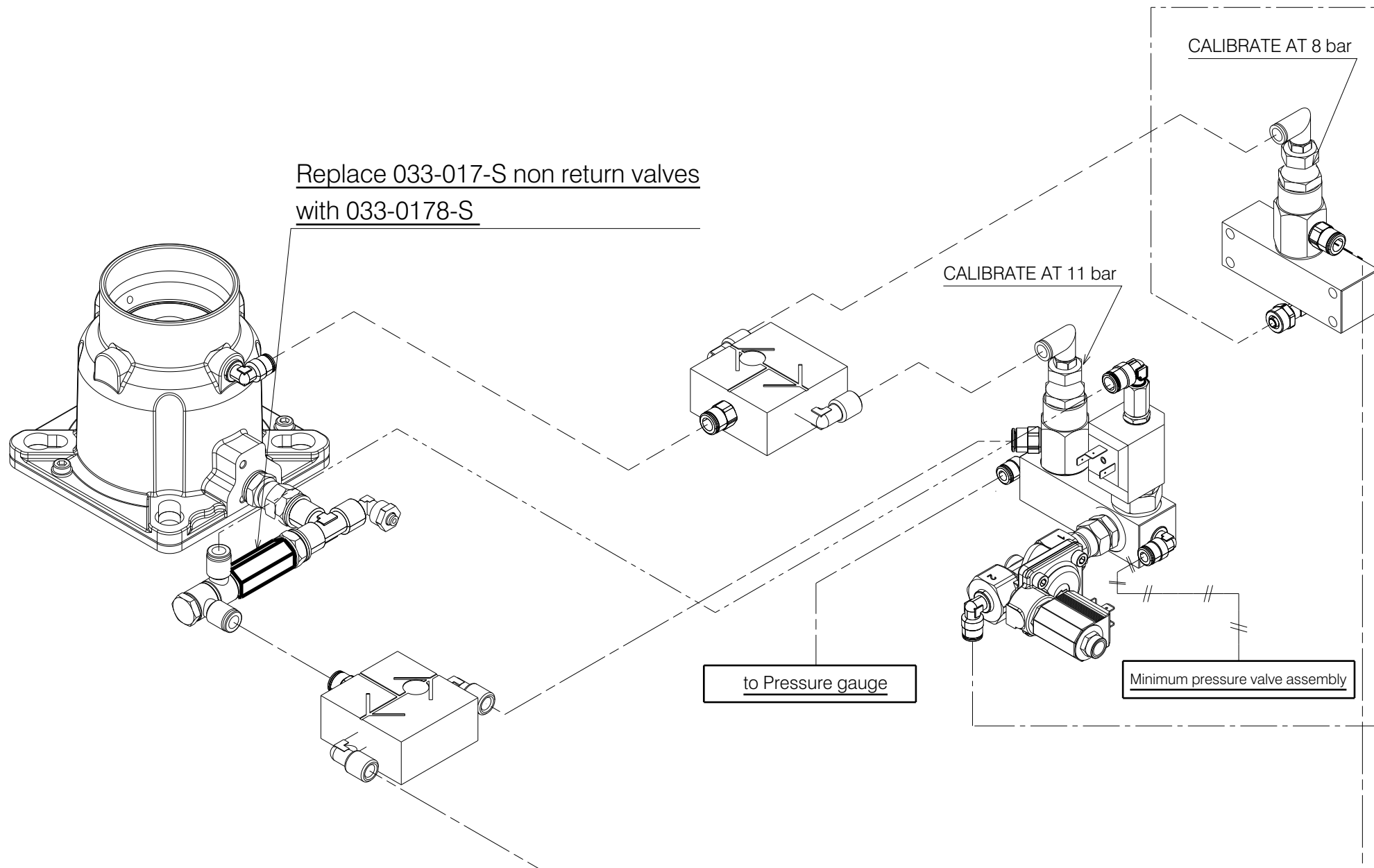

CALIBRATE AT 11 bar

CALIBRATE AT 8 bar

to Pressure gauge

Minimum pressure valve assembly

This page has been intentionally left blank

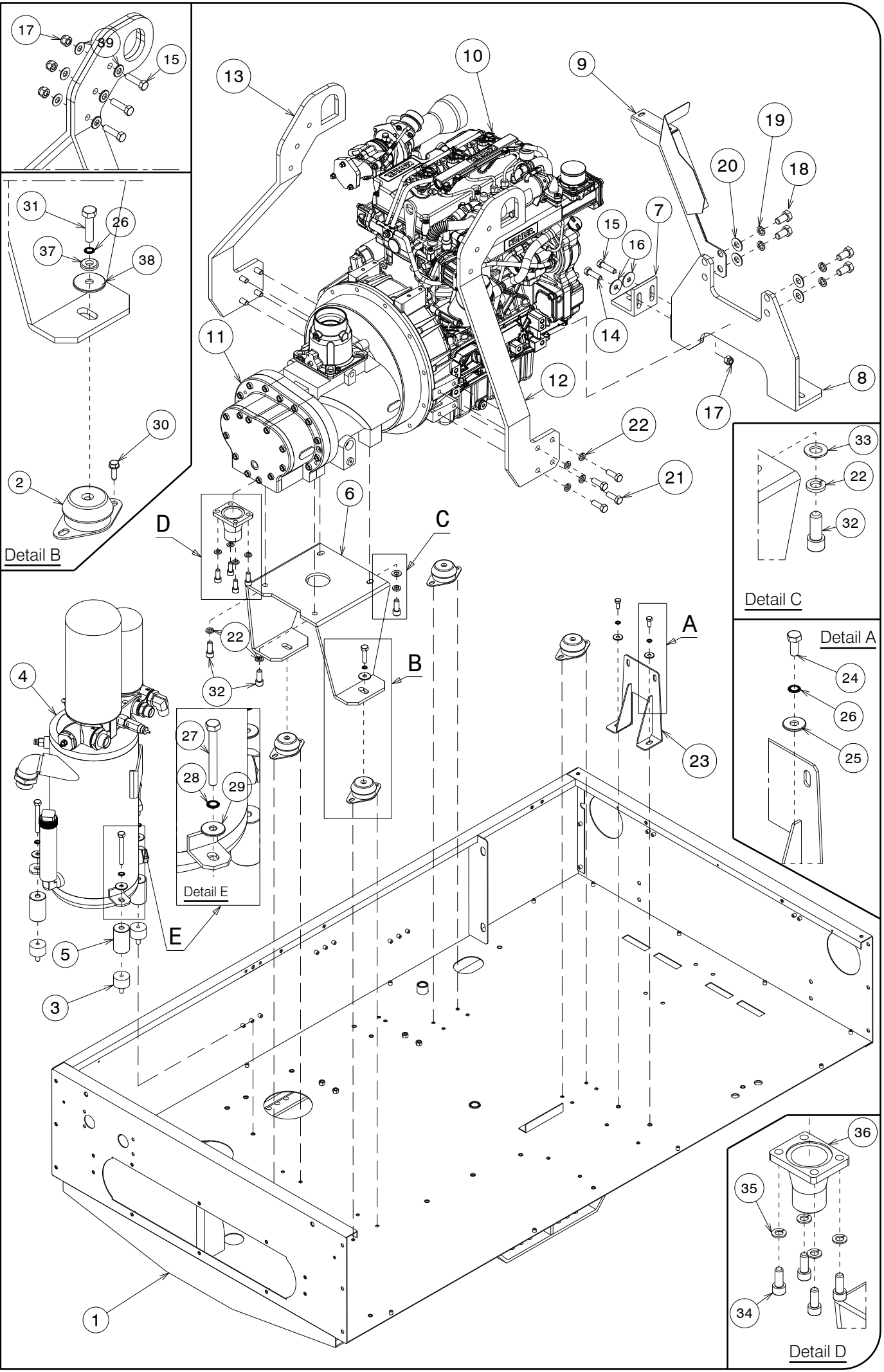



## PARTS LIST

### Motocompressor – D185T4F

**PARTS LEGENDA:** Clampings to the frame

Tab. 05

REF	NAME	CODE	QUANTITY
1	Chassis (Up to serial No. C42374)	038-05260001-S	1
	Chassis (From serial No. C42375 – Up to C44380)	038-05260003-S	1
	Chassis (From serial No. C44381)	038-0525990-S	1
2	Silent Block	061-02370-S	4
3	Silent Block	061-0570-S	3
4	Separator tank assembly	024-6149025-F	1
5	Separator tank spacer	009-12270-S	3
6	Compressor support	027-0901-S	1
7	Engine support L-swinging	039-1153-S	1
8	Engine support	039-115430-S	1
9	Intercooler (OUT) clamping blade	120-3964802-S	1
10	Engine	165-42492-S	1
11	Air end	024-032914614-F	1
12	Right hoisting hook	017-0478505-S	1
13	Left hoisting hook	017-0478525-S	1
14	Hex head screw M12x40 UNI 5739	132-194-S	1
15	Hex head screw M12x45 UNI 5739	132-195-S	4
16	Flat washer d.12,5x40x3	015-0405-S	2
17	Self-locking nut M12	137-060-S	4
18	Hexagonal head screw M.16x40	132-294-S	4
19	Elastic washers d. 16	139-080-S	4
20	Plane washer d. 16x35x3	015-048-S	4
21	Hex head screw M12x35 UNI 5739	132-193-S	8
22	Elastic washer	139-060-S	8
23	Intercooler (IN) clamping blade	120-3964800-S	1
24	Hex head screw M8x20 UNI 5739	132-101-S	2
25	Flat washer 8x24x2 UNI6593	015-031-S	2
26	Schnorr washer d.8	015-251-S	8
27	Hex head screw partially threaded M.10x 80	132-153-S	3
28	Schnorr washer d.10	015-252-S	3
29	Flat washer 10x30x2,5 UNI6593	015-033-S	5
30	Flanged hex head screw M8x20	132-10105-S	8
31	Hex head screw M10x40 UNI 5739	132-145-S	4
32	Hex socket head cap screw M12x30	133-233-S	4
33	Flat washer d.13	015-034-S	2
34	Hex socket head cap screw M10x25	133-182-S	4
35	Elastic washer	139-050-S	4
36	Flex clamping flange	004-0695-S	1
37	Flat washer d.10x22x4	015-0325-S	4
38	Flat washer d.10x40x2.5	015-037-S	4
39	Flat washer 13x27x2,5	015-047-S	6

Detail B

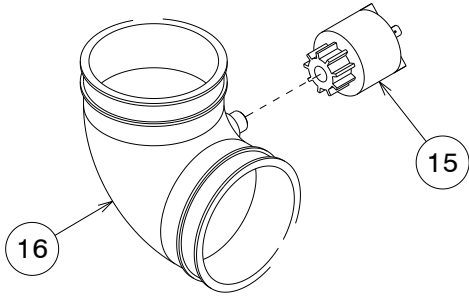

Detail C

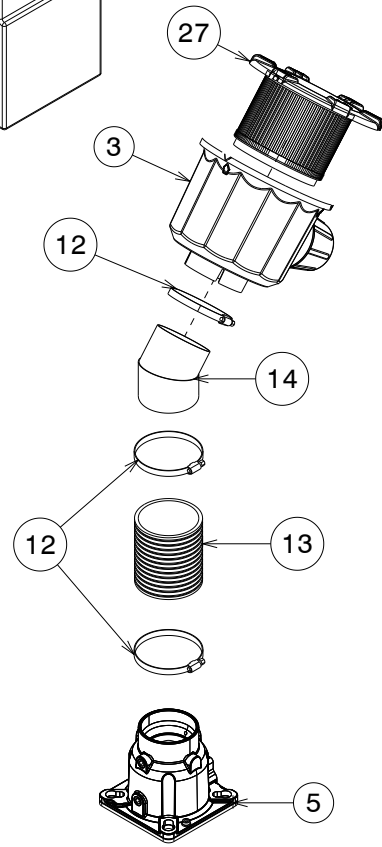
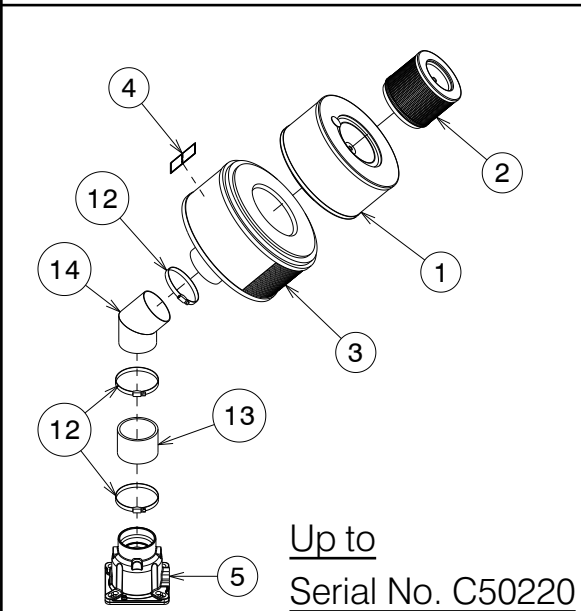
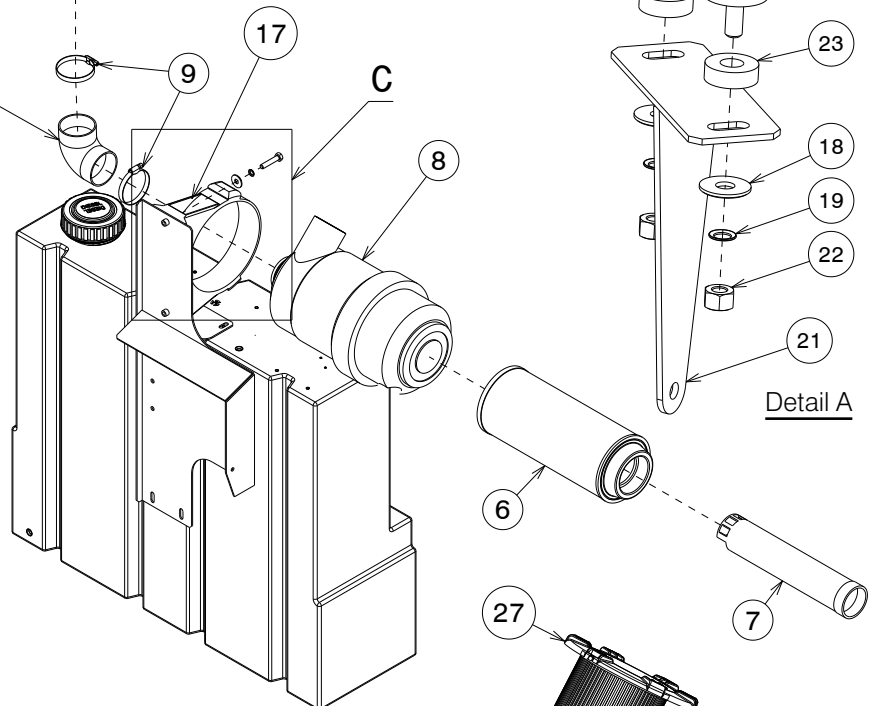
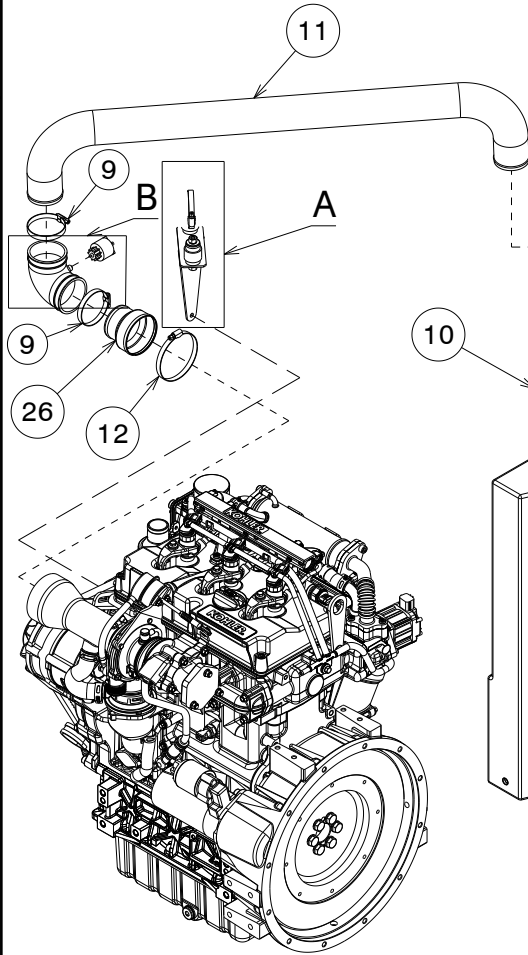
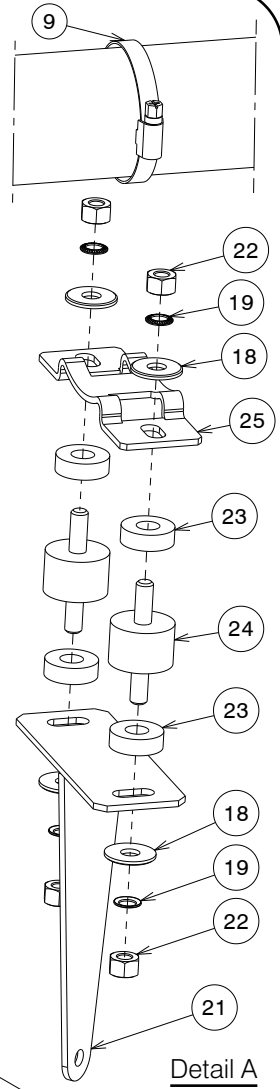
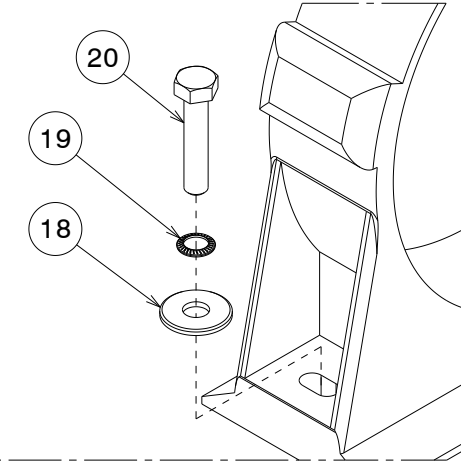



## PARTS LIST

### Motocompressor – D185T4F

PARTS LEGENDA: Air intake

Tab. 06

REF	NAME	CODE	QUANTITY/ LENGTH
Up to serial No. C50220			
1	1° Air filter – Comp.	162-576-S	1
2	2° Air filter – Comp.	162-577-S	1
3	Compressor Air Filter container	014-28962-S	1
12	Pipe clamp d.70x90	149-145-S	3
13	Pipe d.76	089-05630-S	2"
14	Air filter inlet curve	111-10125-S	1
From Serial No. C50280			
3	Compressor Air Filter container	014-2705-S	1
14	Air filter inlet curve	111-09920-S	1
12	Pipe clamp d.70x90	149-145-S	3
13	Pipe d.80	089-043-S	2"
27	Air filter	162-04800-S	1
4	Air filter sticker	238-001-S	1
5	Regulator assembly	024-138181-F	1
6	1° Air filter – Engine	162-0086-S	1
7	2° Air filter – Engine	162-0087-S	1
8	Air cleaner – Engine	014-4221-S	1
9	Pipe clamp d. 50x70	149-1420-S	4
10	Curve d. 60	111-106-S	2
11	Engine inlet pipe	064-16804045-S	1
15	Air filter clogging sensor	257-0470-S	1
16	90° silicone elbow (Up to serial No.C40000)	111-10590-S	1
17	Mann air filter support	010-2418-S	1
18	Flat washer 8x24x2 UNI6593	015-031-S	4
19	Schnorr washer d.8	015-251-S	2
20	Hex head screw M8x40 UNI 5739	132-105-S	2
21	Pipe clamping blade	120-39648045-S	1
22	Hex nut M8 UNI 5587	135-040-S	4
23	Spacer	009-0875-S	4
24	Silent block	061-013-S	2
25	Clamp support	010-1530-S	1
26	Reduction 75 to 60 (From to serial No.C40000)	190-60454-S	1

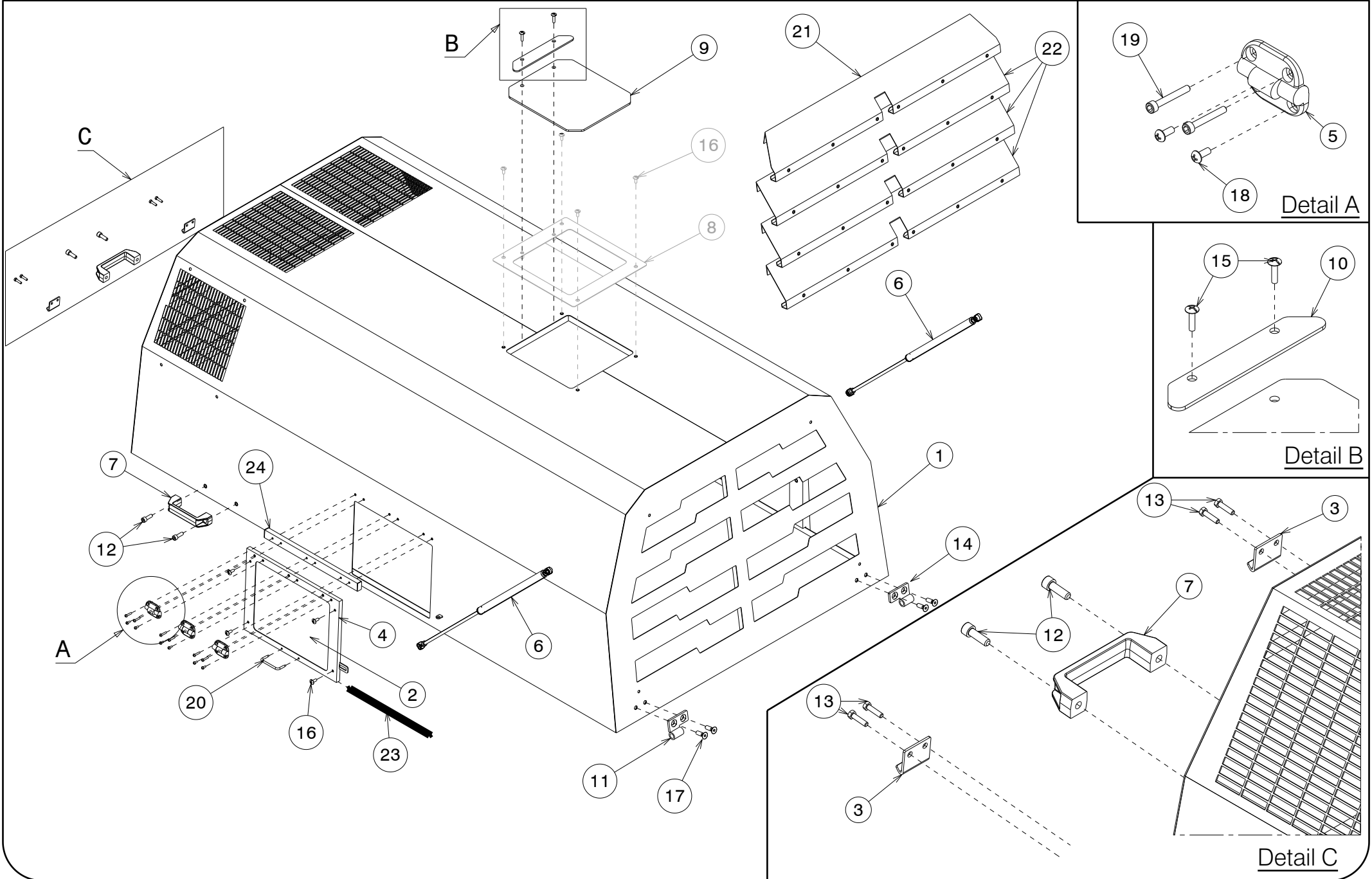



# PARTS LIST

## Motocompressor – D185T4F

PARTS LEGENDA: Canopy

Tab. 07

REF	NAME	CODE	QUANTITY
1	Canopy	036-178621-S	1
2	Control panel plexiglas door	057-0205-S	1
3	Lock plate	208-001-S	2
4	Control panel door	110-10031-S	1
5	Hinge	007-032-S	3
6	Lifting piston	091-09720-S	2
7	Plastic handle	209-009-S	3
8	Rubber plate closing plate – Up to S/N C47122	124-30789402-S	1
9	Rubber plate for hosting hook	177-1915-S	1
10	Rubber fastener plate	208-0042-S	1
11	Fixed left hinge	007-007502-S	1
12	Hex socket head cap screw M8x25 UNI 5931	133-133-S	6
13	Hex head screw M5x20 UNI 5739	132-040-S	4
14	Fixed right hinge	007-007500-S	1
15	Large head screw M6x25	243-012-S	2
16	Large head screw M6x16 – Up to S/N C47122	243-009-S	4
17	Hexagon socket countersunk head 10x20 UNI 5933	146-151-S	4
18	Large head screw M6x10	243-088-S	6
19	Hex socket head screw M4x30	133-046-S	6
20	Panel door hinge	209-021-S	1
21	Upper soundproofing panel	124-307908-S	1
22	Soundproofing panel	124-307906-S	3
REF	NAME	CODE	LENGTH
23	Gasket rubber reinforced profile	023-209-S	13.50"
24	Control panel door support blade	120-3964150-S	1
25	Large head screw 6x10	243-008-S	4

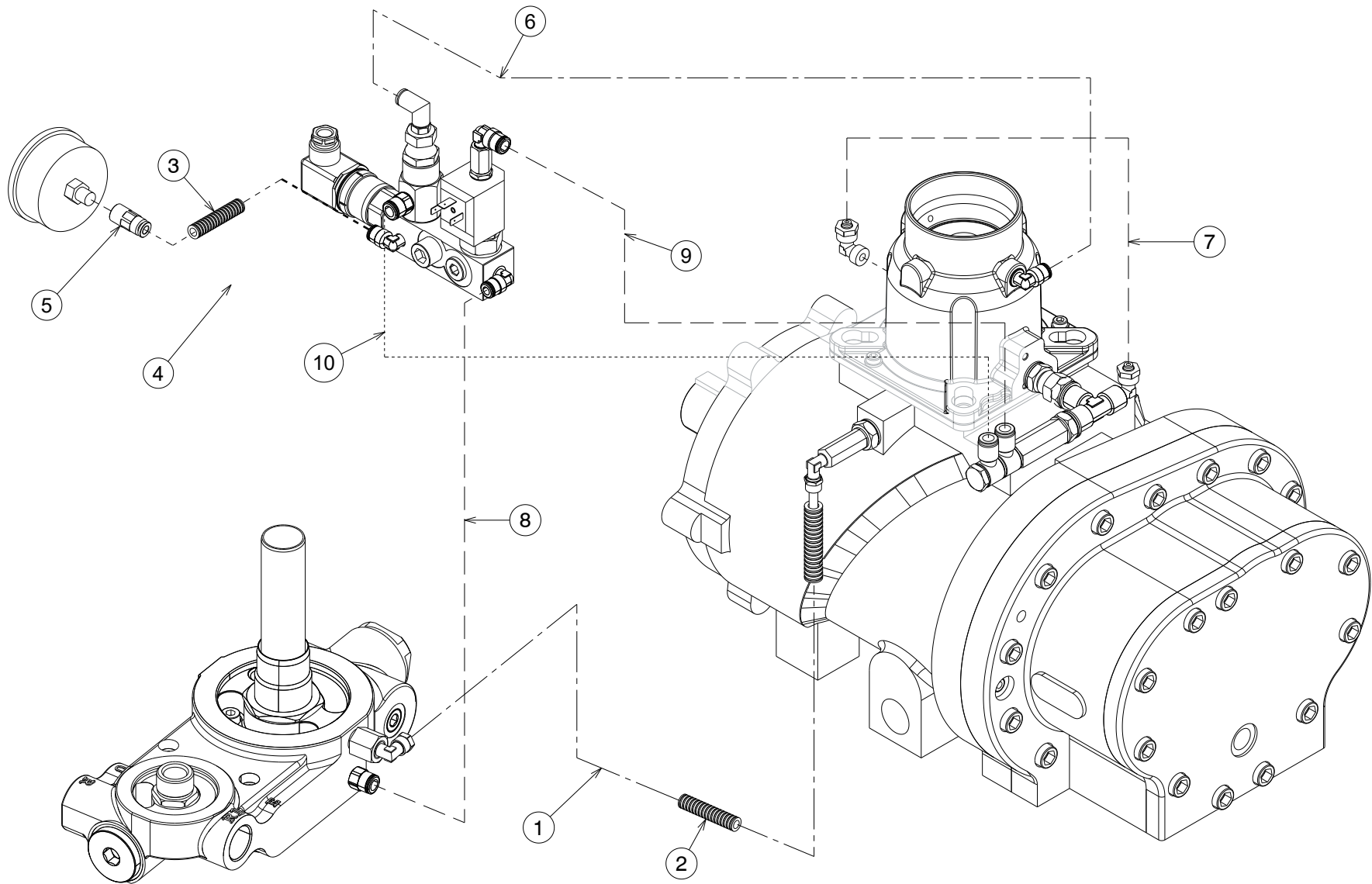



## PARTS LIST

### Motocompressor – D185T4F

**PARTS LEGENDA:** Pneumatic system

Tab. 08.1

REF	NAME	CODE	QUANTITY
1	Polyamides pipe d.6	089-060-S	24 in
2	Corrugated pipe d.7.5	089-191-S	21,50 in
3	Rilsan pipe d.6	089-0605-S	78 in
4	Corrugated pipe d.7.5	089-191-S	76 in
5	Straight quick coupling F ( 1/8" ) for pipe d.6	148-5765-S	1
6	Rilsan pipe d.8	089-0705-S	25,60 in
7			15 in
8			24 in
9			25 in

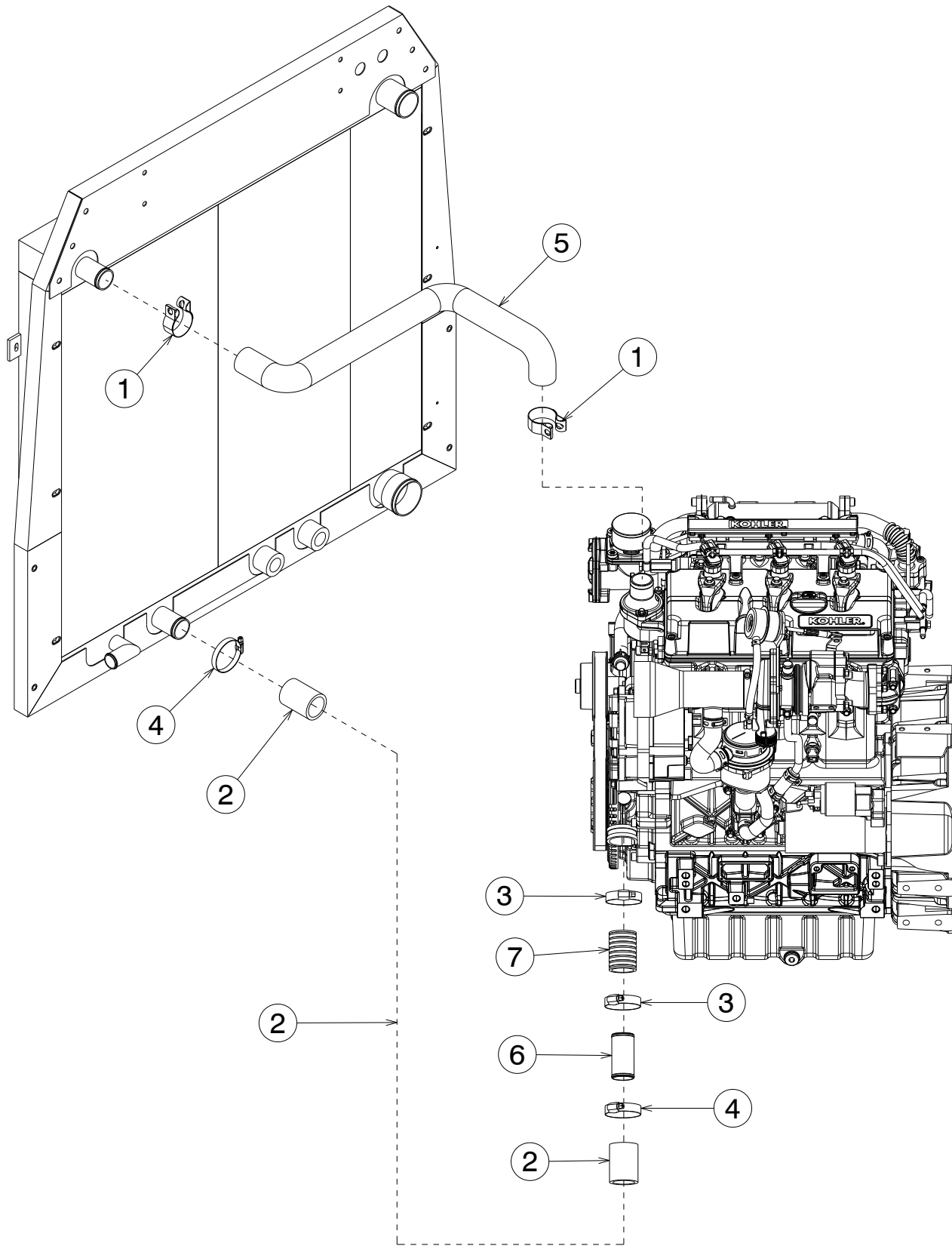



## PARTS LIST

### Motocompressor – D185T4F

**PARTS LEGENDA:** Cooling system

Tab. 08.2

REF	NAME	CODE	QUANTITY/ LENGHT
1	Clamp cost.torque 40-43	149-309-S	2
2	Calorflex pipe diam.35x45	089-006-S	21"
3	Clamp 32x50	149-131-S	2
4	Clamp cost.torque 32-54	149-1321-S	2
5	Rubber pipe	090-17500-S	1
6	Reduction d.35 L=70 (From serial No.C39796)	190-613953-S	1
7	Radiator pipe d.35x43 (From serial No.C39796)	089-00560-S	9.80 "





## PARTS LIST

### Motocompressor – D185T4F

**PARTS LEGENDA:** Compensation tank

Tab. 08.2.1

REF	NAME	CODE	QUANTITY/ LENGTH
1	Water – oil radiator	011-10430-S	1
2	Radiator support	049-115535-S	1
3	Compensation tank	201-018505-S	1
4	Fitting M (1/4") for pipe d. 8	148-198.2-S	3
5	Joint M (3/4") for pipe d. 25	148-19970-S	1
6	Clamp diam. 8-11	149-005-S	4
7	T Fitting M+F+F 1/4"	148-1942-S	1
8	Clamp 26-45	149-1280-S	2
9	Calorflex pipe	089-009.5-S	45"
10	Fitting 90° M+F 1/4"	148-143-S	1
11	Copper washer ( 3/4" )	015-015-S	2
12	Double screw 3/4 hole 19,1 Din standard	187-060-S	2
13	Anti-oil pipe for fuel 15x8	089-1203-S	21"
14			31"
15			56"

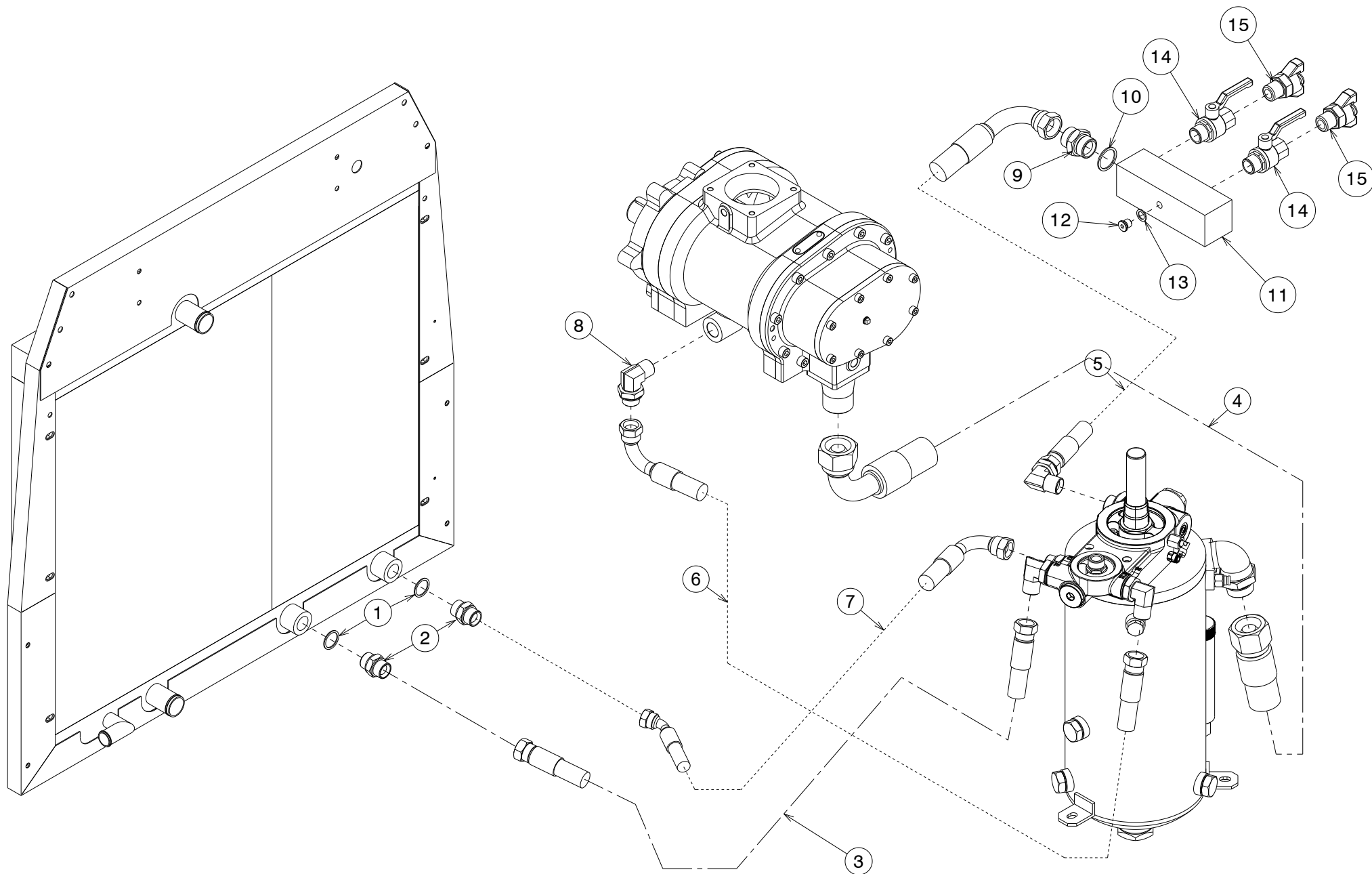



## PARTS LIST

### Motocompressor – D185T4F

**PARTS LEGENDA:** Oleopneumatic system

Tab. 08.3

REF	NAME	CODE	QUANTITY
1	Copper washer ( $\frac{3}{4}$ " )	015-015-S	2
2	Double screw ( $\frac{3}{4}$ " )	187-060-S	2
3	Hose ( $\frac{3}{4}$ " )	065-725.2-S	1
4	Hose ( 1 $\frac{1}{4}$ " )	065-3019.500-S	1
5	Hose ( 1" )	065-852.95-S	1
6	Hose ( $\frac{3}{4}$ " )	065-717-S	1
7	Hose ( $\frac{3}{4}$ " )	065-779.744-S	1
8	90° fitting M+M ( $\frac{3}{4}$ " )	148-2985-S	1
9	Double screw ( 1" )	187-070-S	1
10	Copper washer ( 1" )	015-018-S	1
11	Exit valves clampings sleeve	063-106700-S	1
12	Plug (1/4")	106-086-S	1
13	Copper washer ( $\frac{1}{4}$ " )	015-007-S	1
14	Ball valve M+F (3/4")	152-030-S	2
15	Bayonet coupling (3/4")	148-650-S	2

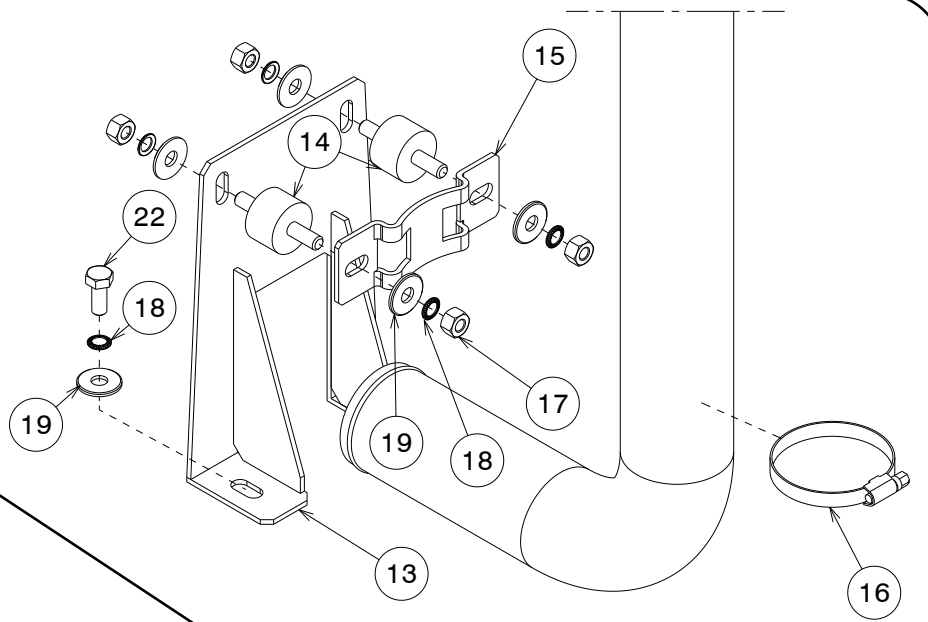
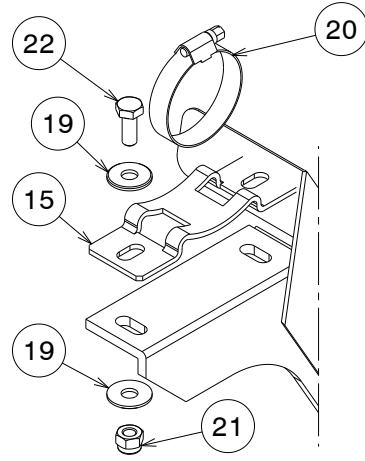
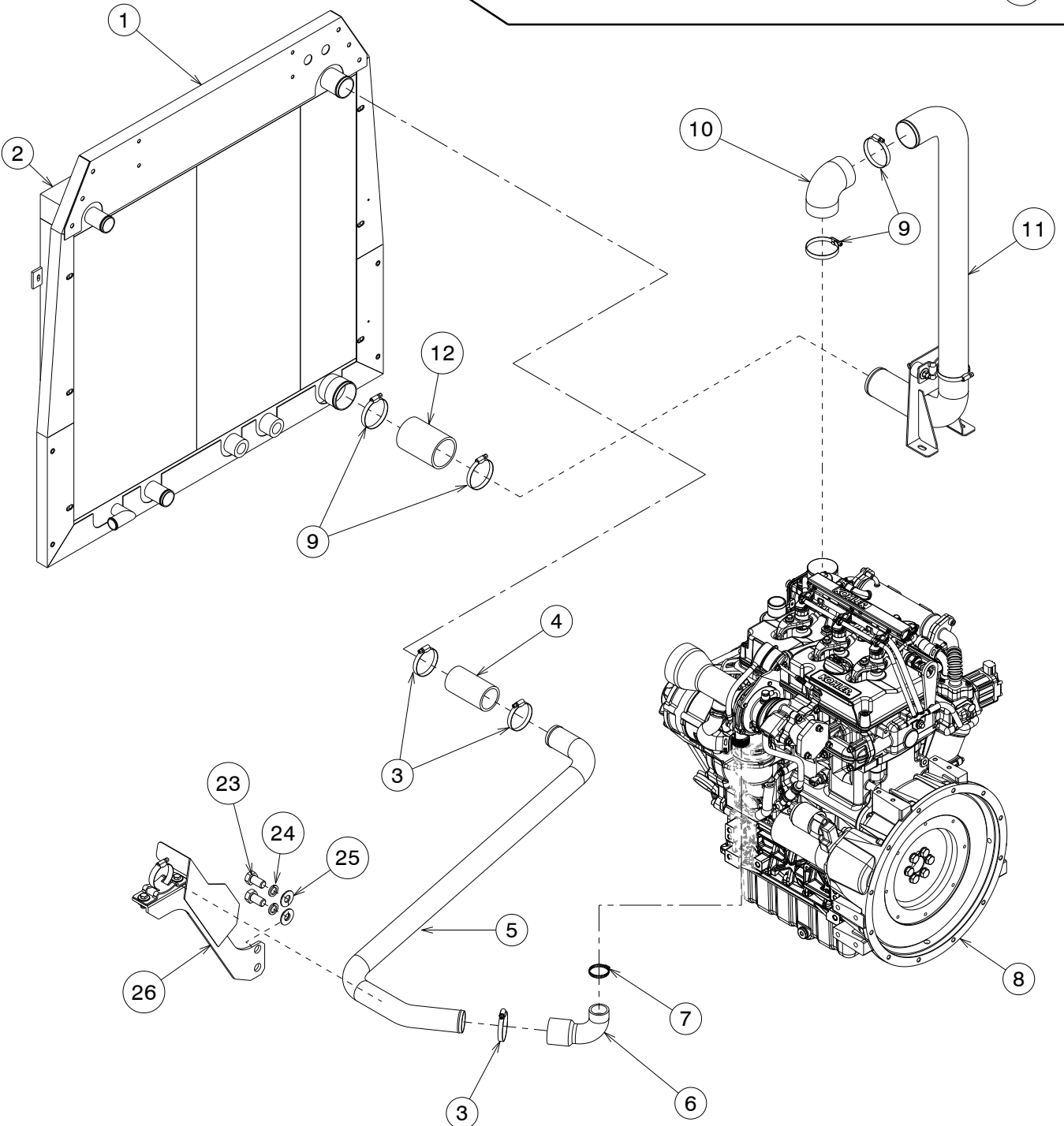



## PARTS LIST

### Motocompressor – D185T4F

**PARTS LEGENDA:** Intercooler system

Tab. 08.4

REF	NAME	CODE	QUANTITY
1	Radiator support	049-115535-S	1
2	Water-Air-Oil radiator	011-10430-S	1
3	Clamp diam.45-67	149-1360-S	3
4	Silicone pipe d.45	089-0155-S	4.70 "
5	Intercooler output pipe	064-16802-S	1
6	Curve 90° diam.45x32	111-106720-S	1
7	Clamp diam.32x54	149-1321-S	1
8	Engine	165-42492-S	1
9	Clamp diam. 57-79	149-1420-S	4
10	Curve d.60	111-10605-S	1
11	Intercooler input pipe	064-16800-S	1
12	Silicone pipe d.60	089-0325-S	4.70 "
13	Engine air intake clamping blade	120-3964800-S	1
14	Silent block M8x20	061-013-S	2
15	Normafix Clamp support K1 D.63-80	010-1530-S	2
16	Clamp diam. 50x70	149-140-S	1
17	Hex nut M8 UNI 5587	135-040-S	4
18	Schnorr washer d.8	015-251-S	6
19	Flat washer 8x24x2 UNI6593	015-031-S	8
20	Clamp diam.32x50	149-131-S	1
21	Self locking nut M8 UNI 7473	137-040-S	2
22	Hex head screw M8x20 UNI 5739	132-101-S	4
23	Hex head screw M16x30	132-292-S	2
24	Elastic washers d.16	139-080-S	2
25	Plane washer d. 16x35x3	015-048-S	2
26	Intercooler pipe support	120-3964802-S	1

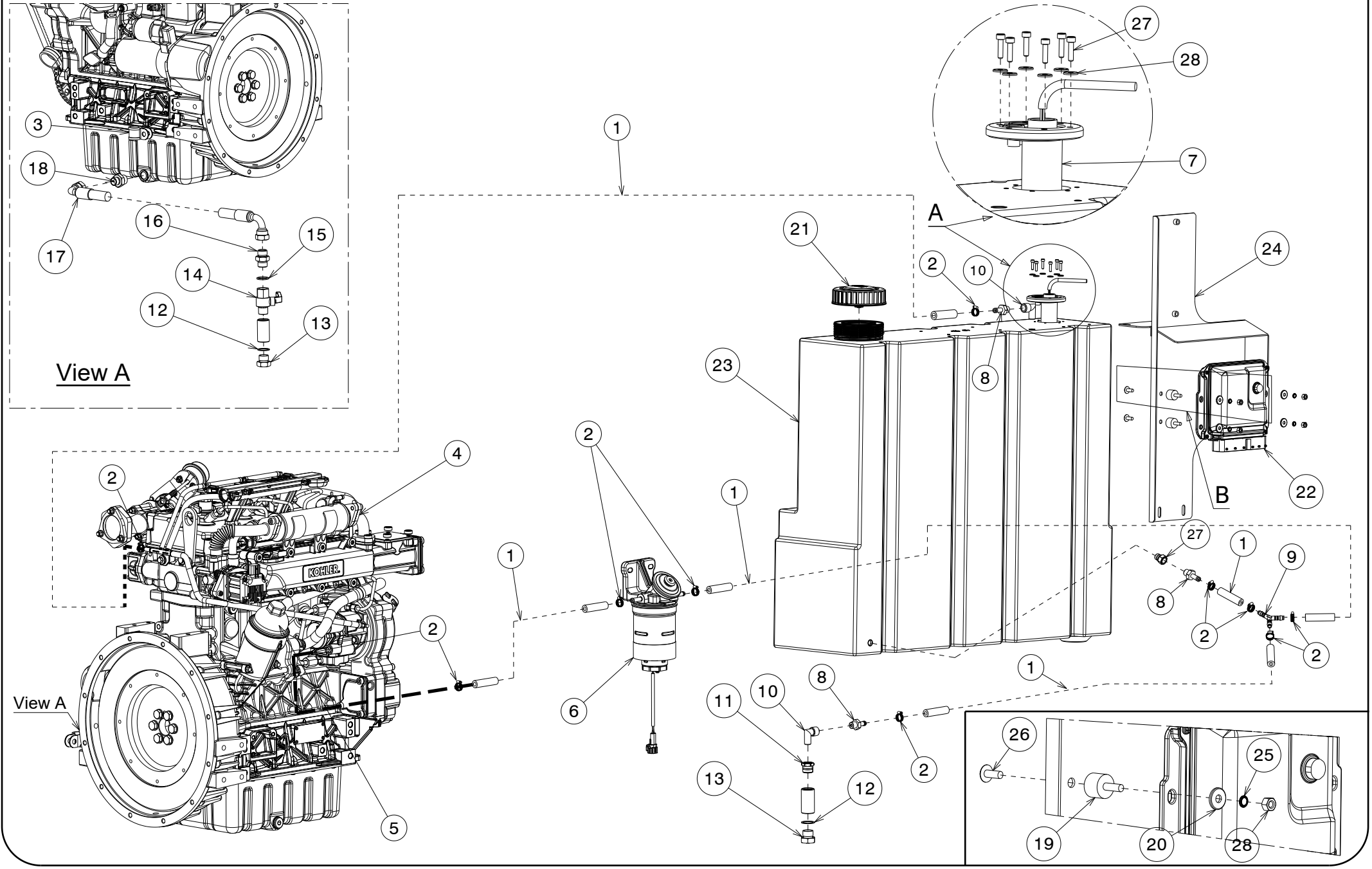



## PARTS LIST

### Motocompressor – D185T4F

**PARTS LEGENDA:** Fuel system

Tab. 08.5

REF	NAME	CODE	QUANTITY
1	Anti-oil pipe for fuel 15x8	089-120-S	5
2	Pipe clamp 10x16	149-0092-S	11
3	Clamp	149-236-S	2
4	Engine	165-42492-S	1
5	Engine oil filter	511-22-0000	1
6	Fuel filter	191-0950-S	1
7	Diesel level control assembly	024-0192-S	1
8	M fitting ( 1/4" ) d.8 with OR	148-198.21-S	3
9	Y Fitting	148-1976-S	1
10	90° M+F fitting ( 1/4" )	148-143-S	2
11	Reduction (1/2") M conical to (1/4") F cylindrical	190-001-S	1
12	Copper washer ( 1/2" )	015-012-S	2
13	Iron plug ( 1/2" )	106-125-S	2
14	Ball valve	152-020-S	1
15	Copper washer	015-0121-S	1
16	Double screw ( 1/2" foro 12.6 )	187-045-S	1
17	Pipe 1/2 F90 + F90	065-383.5-S	1
18	Double screw	187-040-S	1
19	Silent block	061-019800-S	4
20	Washer d. 6.6x18x2	015-029-S	12
21	Fuel tank plug	193-0420-S	1
22	Electronic card ( it comes with the engine )	---	1
23	Diesel tank	201-02370-S	1
24	Engine's control support blade	010-31590485-S	1
25	Washer d.6	015-250-S	4
26	Hexagonal head screw M6x12 UNI 5739	132-061-S	4
27	Straight adapter fitting 1/4"M conical – 1/4"F cil.	148-03600-S	1
28	Hex nut d.6	135-030-S	4

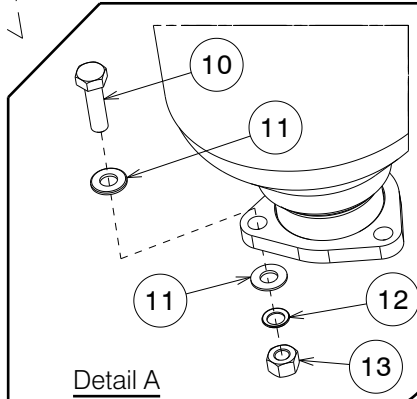
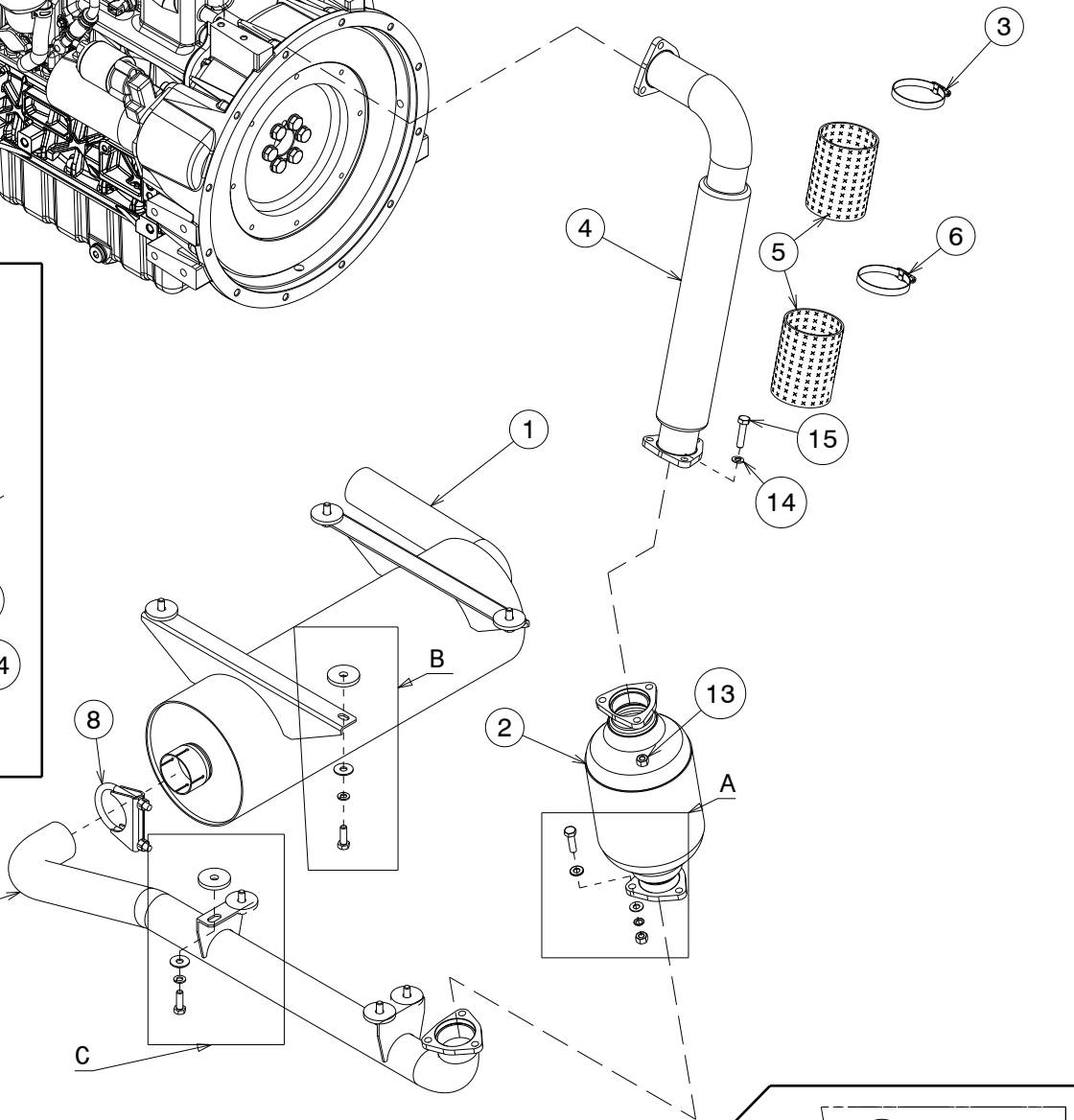
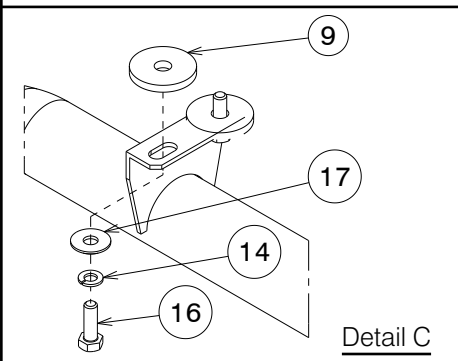
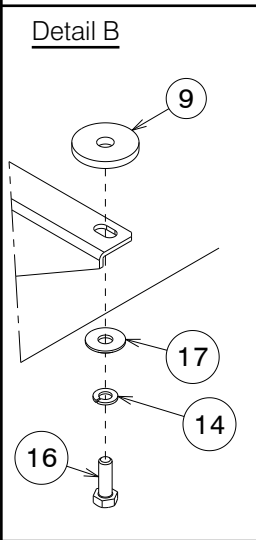
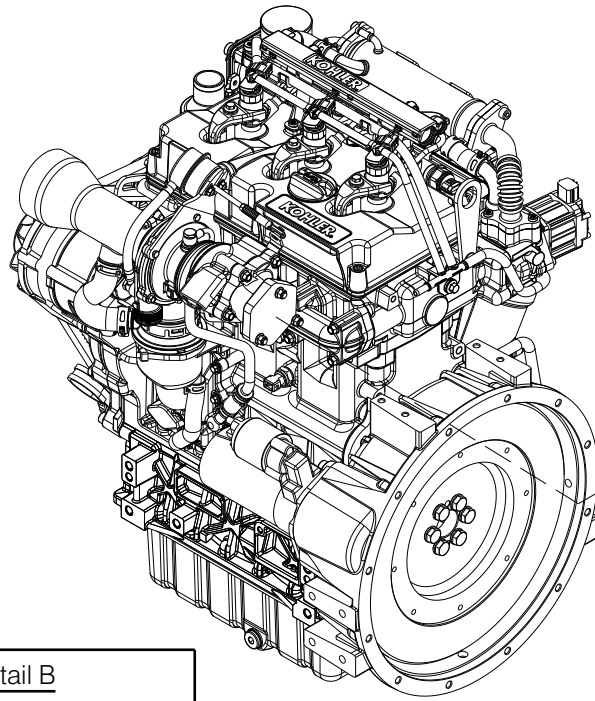



## PARTS LIST

### Motocompressor – D185T4F

**PARTS LEGENDA:** Exhaust system

Tav. 08.6

REF	NAME	CODE	QUANTITY
1	Muffler	042-087801-S	1
2	Catalyst	----	1
3	Pipe clamp d.40x60	149-135-S	1
4	Flex pipe	090-101800-S	1
5	Fiber glass braiding d.70	097-0325-G	1
6	Pipe clamp d.50x70	149-140-S	1
7	Exhaust collector pipe	119-07601-S	1
8	Pipes clamp d.54x8	149-070-S	1
9	Seal for muffler d.40 th..5	023-077-S	8
10	Hex head screw M8x30	132-103-S	3
11	Flat washer 8,4x17x1,5 UNI 6592	015-030-S	6
12	Schnorr washer d.8	015-251-S	3
13	Hex nut M8 UNI 5587	135-040-S	6
14	Elastic washer d.8	139-040-S	11
15	Hexagonal head screw M8x30 UNI 5739	132-104-S	3
16	Hex head screw M8x25 UNI 5739	132-102-S	8
17	Flat washer 8x24x2 UNI6593	015-031-S	6



1

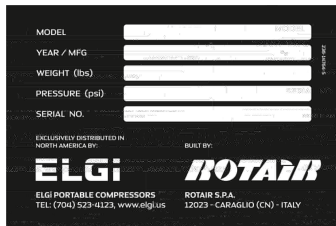

3



4

2

6

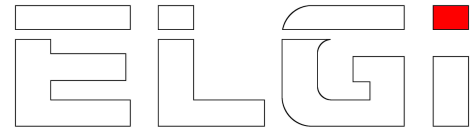

5



7

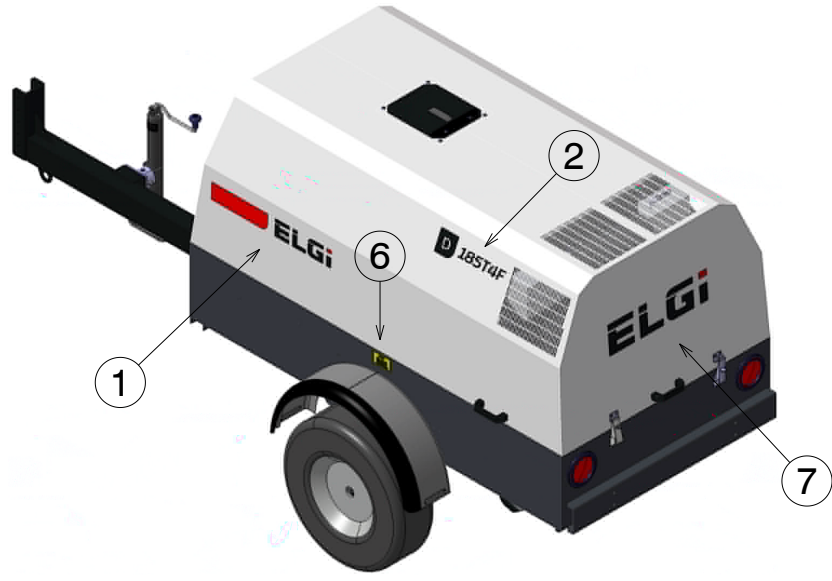



## PARTS LIST

### Motocompressor – D185T4F

**PARTS LEGENDA:** Decals

Tab. 09

REF	NAME	CODE	QUANTITY
1	"ELGI Brand" decal	238-3274010-S	2
2	"D 185 T4F" decal	238-3258235-S	2
3	Warnings decal	238-01030-S	1
4	Serial No.plate	238-14764-S	1
5	"ELGI white" decal	238-3274014-S	1
6	"CAUTION DIESEL ONLY" decal	238-097600-S	1
7	"ELGI black" decal	238-3274018-S	1

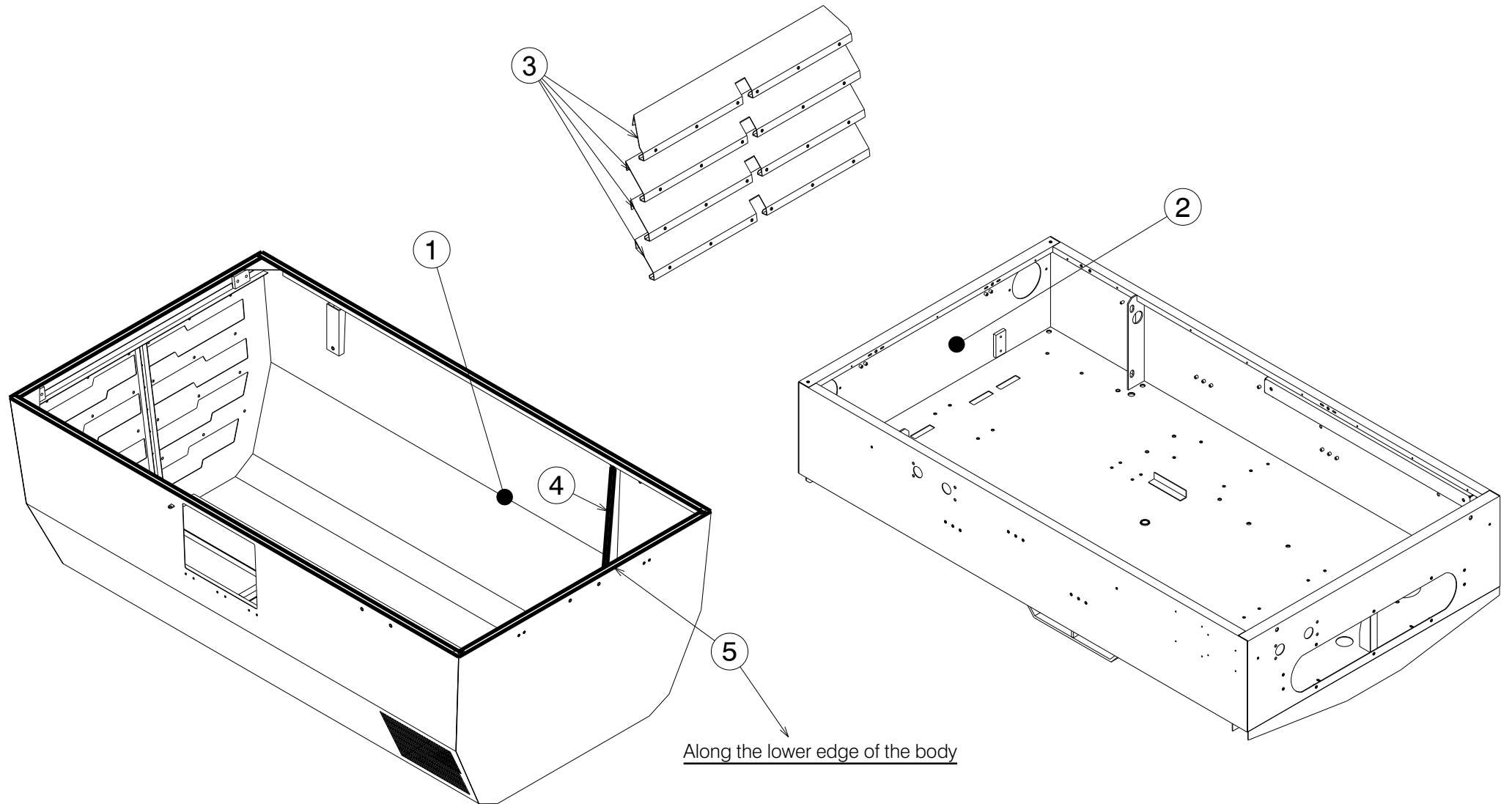



## PARTS LIST

### Motocompressor – D185T4F

**PARTS LEGENDA:** Sound-proofing

Tab. 10

REF	NAME	CODE	QUANTITY/ LENGTH
1	Canopy sound-proofing kit	204-313015-S	1
2	Chassis sound-proofing kit	204-34402-S	1
3	Air intake sound-proofing kit	204-34404-S	1
4	Straight SIC profile gasket	023-231-S	34"
5	Adhesive gasket 20X5	023-351-S	220 "

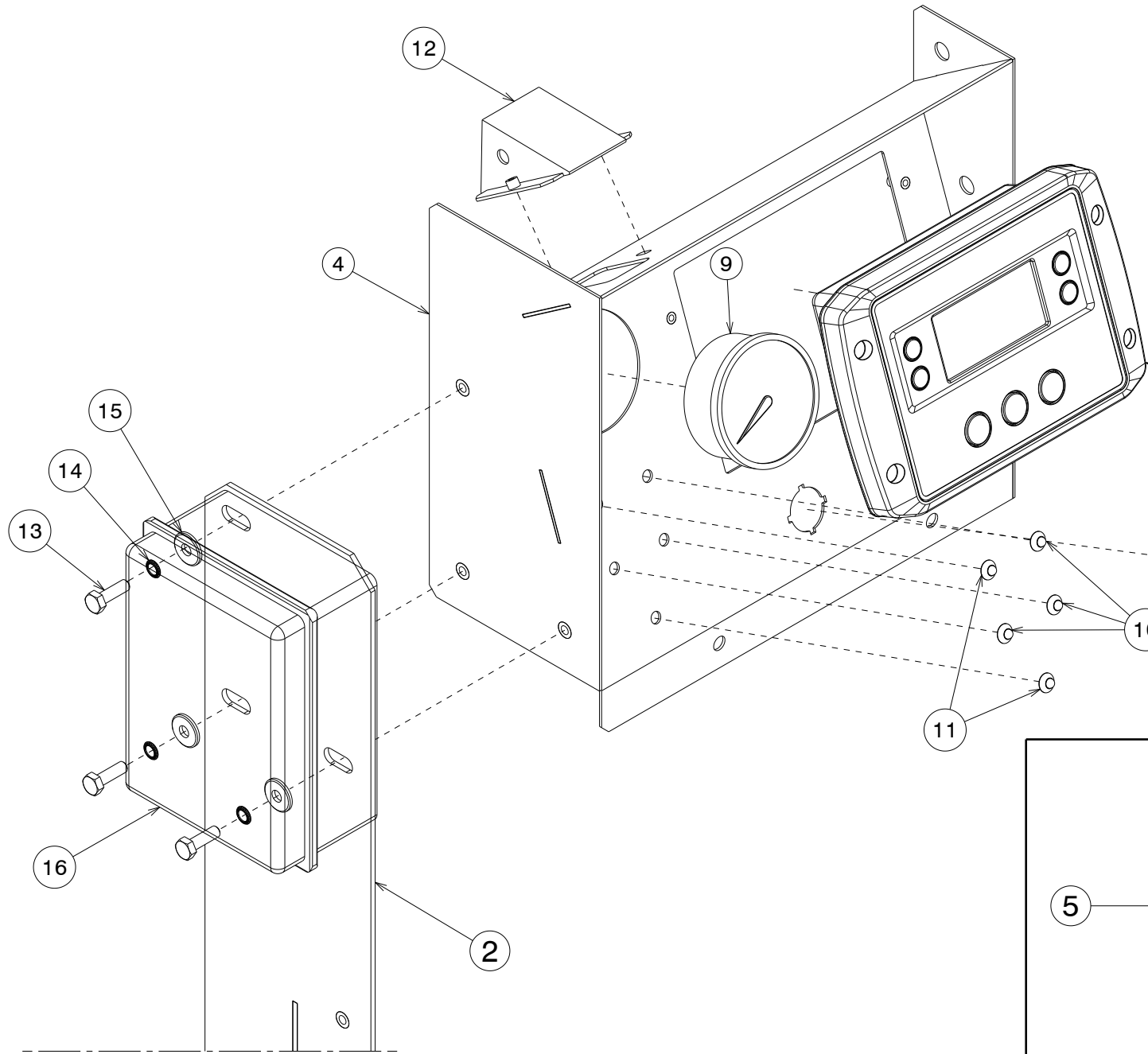

Electrical Harness

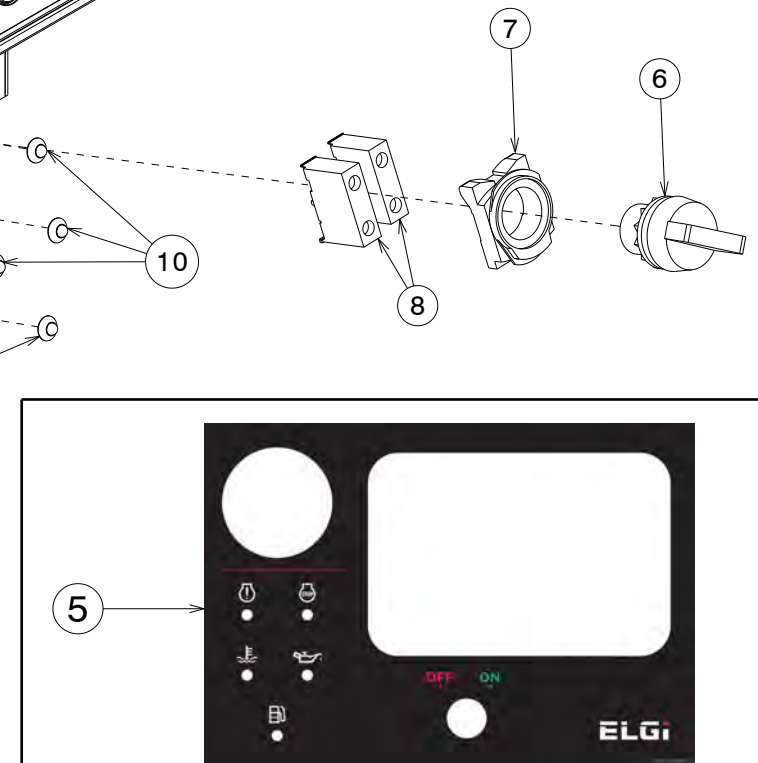
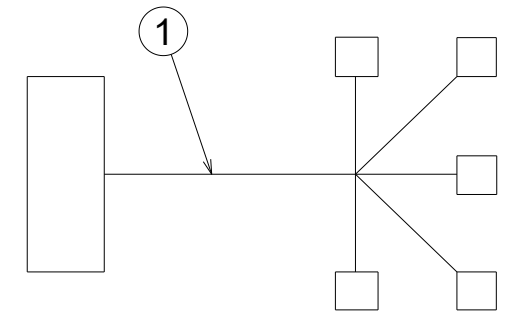



# PARTS LIST

## Motocompressor – D185T4F

**PARTS LEGENDA:** Control panel – Electrical harness

Tab. 11

REF	NAME	CODE	QUANTITY
1	Electrical harness	224-470621-S	1
2	Control panel support blade	010-315903-S	1
3	Control board	269-423725-S	1
4	Control panel	040-04270-S	1
5	Control panel sticker	238-1632007-S	1
6	Two-positions selector	249-022-S	1
7	Contact holder	127-376-S	1
8	Contact	127-375-S	2
9	Pressure gauge	206-020-S	1
10	Red warning light	183-011-S	3
11	Yellow warning light	183-041-S	2
12	Temperature sensor protection carter	005-063900-S	1
13	Hex head screw M6x25	132-065-S	3
14	Schnorr washer d.6	015-250-S	3
15	Washer d. 6.6x12x1,5	015-027-S	3
16	Electrical box	029-200-S	1
<b>Control panel Assembly</b>		<b>024-566100-F</b>	



# PARTS LIST

## Motocompressor – D185T4F

**LEGENDA: Service Kits**

**Tab. 12**

### 50 HOUR SERVICE KIT FOR D185T4F

Part #	Description	Quantity
<b>519-11-0001</b>	<b>50 HOUR SERVICE KIT</b>	<b>1</b>
<b>THE KIT INCLUDES</b>		
099-008-S	COMPRESSOR OIL FILTER	1
512-12-0000	COMPRESSOR OIL 2.5 GAL	1
511-21-0002	ENGINE FUEL FILTER	1
511-22-0000	ENGINE OIL FILTER	1
512-15-0007	10W30 SYNTH ENGINE OIL	1
<b>TOTAL:</b>		<b>5</b>

### 250 HOUR SERVICE KIT FOR D185T4F

Part #	Description	Quantity
<b>519-21-0321</b>	<b>250 HOUR SERVICE KIT</b>	<b>1</b>
<b>THE KIT INCLUDES</b>		
099-008-S	COMPRESSOR OIL FILTER	1
162-0086-S	PRIMARY ENGINE AIR	1
162-0087-S	SECONDARY ENGINE AIR	1
162-576-S	COMPRESSOR AIR FILTER	1
162-577-S	COMPRESSOR SECONDARY AIR FILTER	1
512-12-0000	COMPRESSOR OIL 2.5 GAL	1
511-21-0002	ENGINE FUEL FILTER	1
511-22-0000	ENGINE OIL FILTER	1
512-15-0007	10W30 SYNTH ENGINE OIL	1
<b>TOTAL:</b>		<b>9</b>

### 500 HOUR SERVICE KIT FOR D185T4F

Part #	Description	Quantity
<b>519-12-0007</b>	<b>500 HOUR SERVICE KIT</b>	<b>1</b>
<b>THE KIT INCLUDES</b>		
099-008-S	COMPRESSOR OIL FILTER	1
157-171-S	SEPARATOR FILTER	1
162-0086-S	PRIMARY ENGINE AIR	1
162-0087-S	SECONDARY ENGINE AIR	1
162-576-S	COMPRESSOR AIR FILTER	1
162-577-S	COMPRESSOR SECONDARY AIR FILTER	1
512-12-0000	COMPRESSOR OIL 2.5 GAL	1
511-21-0002	ENGINE FUEL FILTER	1
511-22-0000	ENGINE OIL FILTER	1
512-15-0007	10W30 SYNTH ENGINE OIL	1
<b>TOTAL:</b>		<b>10</b>



## PARTS LIST

### Motocompressor – D185T4F

**LEGENDA: Options**

**Tab. 13**

#### D185T4F SKID

Part #	Description	Quantity
038-052601020-S	SKID FOR D185T4F	1
061-0065-S	SILENT BLOCK FOR D185T4F, D300T4F, D400/425T4F SKID MOUNT	4

#### D185T4F CWB

Part #	Description	Quantity
509-12-0007	BLOCK HEATER - KOHLER D185T4F, D300T4F	1
509-12-0006	BLOCK HEATER CORD - KOHLER D185T4F, D300T4F	1
509-12-0005	BUSHING FOR BLOCK HEATER - KOHLER D185T4F, D300T4F	1
507-24-0001	BATTERY 760 CCA AGM MTX-48/H6 FOR D90, D185, D400, D425, CWP	1

#### D185T4F DHR

Part #	Description	Quantity
580-10-0001	HOSE REEL HAND CRANK 50'	2
518-12-0017	26" BLACK HOSE FROM COMPRESSOR TO HOSE REEL	2
518-12-0016	3/4" RED JACK HAMMER HOSE 50'	2
529-15-0000	DRAWBAR WITH HOSE REEL BRACKETS D185T4F	1

#### D185T4F DP

Part #	Description	Quantity
044-093065-S	Dual Pressure/Dual Flow Kit D185T4F w/DeepSea Controller	1