



# YARD FORCE®

OUTDOOR POWER EQUIPMENT

YF24-DS21-GSB

## 24" DUAL-STAGE SNOW BLOWER OPERATOR'S MANUAL

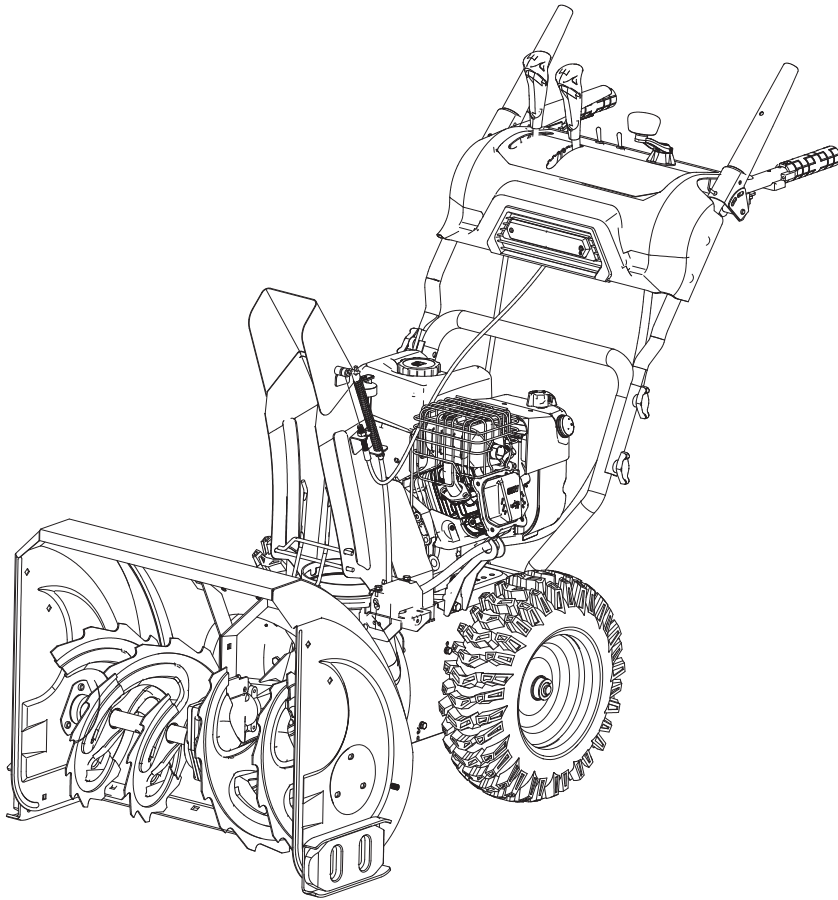

*Our Customer Service staff is ready to provide assistance.*

*In the case of a damaged or missing part, most replacement parts ship directly from Merotec USA in Atlanta or from one of our service partners in the US.*

*For immediate help with assembly, or for additional product information, email support@MerotecUSA.com or call 866-902-9690 M-F 8:30am – 5:00pm ET. More information can be found on [www.YardForceUSA.com](http://www.YardForceUSA.com).*

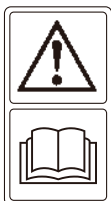

### **SAVE THIS MANUAL FOR REFERENCE**

*You will need this manual for safety instructions, operating procedures, and Warranty. The original sales receipt is required for warranty service.*

## TABLE OF CONTENTS

<b>Product Specifications</b> .....	3
<b>Safe Operation Practices</b> .....	3
<b>Package Contents</b> .....	7
<b>Assembly</b> .....	7
<b>Operation</b> .....	10
<b>Maintenance</b> .....	13
<b>Service And Adjustment</b> .....	18
<b>Safety Symbols</b> .....	21
<b>Troubleshooting</b> .....	23
<b>Warranty</b> .....	24

## PRODUCT SPECIFICATIONS

Model	YF24-DS21-GSB
Engine displacement	208 cc
Clearing width	24" (61 cm)
Clearing depth	21" (53cm)
Discharge distance	35' (10.7 m)
Drive system	6 forward & 2 reverse speeds
Chute adjustment	180° joystick
One-hand operation	Yes
Drive control	Auto-turn power steering
Chute Deflector control	Control knob
LED light	6 W
Wheels	16" (41 cm)
Weight	220 lb. (100kg)

## READ ALL INSTRUCTIONS!



### READ & UNDERSTAND OPERATOR'S MANUAL



**WARNING:** Some dust created by power sanding, sawing, grinding, drilling and other construction activities contains chemicals known to the state of California to cause cancer, birth defects or other reproductive harm. Some examples of these chemicals are:

- ∫ Lead from lead-based paints
- ∫ Crystalline silica from bricks and cement and other masonry products, and
- ∫ Arsenic and chromium from chemically-treated lumber.

Your risk from these exposures varies, depending on how often you do this type of work. To reduce your exposure to these chemicals: work in a well ventilated area, and work with approved safety equipment, such as those dust masks that are specially designed to filter out microscopic particles. For more information, go to [www.P65Warnings.ca.gov](http://www.P65Warnings.ca.gov).

## SAFE OPERATION PRACTICES



**DANGER:** This machine was built to be operated according to the rules for safe operation in this manual. As with any type of power equipment, carelessness or

error on part of the operator can result in serious injury. This machine is capable of amputating hands and feet and throwing objects. Failure to observe the following safety instructions could result in serious injury or death.



**WARNING:** Engine Exhaust, some of its constituents, and certain vehicle components contain or emit chemicals known to cause cancer and birth defects or other reproductive harm.



**WARNING:** This symbol points out important safety instructions which, if not followed, could endanger the personal safety and/or property of yourself and others. Read and follow all instructions in this manual before attempting to operate this machine. Failure to comply with these instructions may result in personal injury. When you see this symbol. **HEED ITS WARNING!**

**Your Responsibility:** Restrict the use of this power machine to persons who read, understand and follow the warnings and instructions in this manual and on the machine.

## IMPORTANT

### Safe Operation Practices for Walk-Behind Snow Blower

This snow blower is capable of amputating hands and feet and throwing objects. Failure to observe the following safety instructions could result in serious injury.

## SAFETY INSTRUCTIONS

1. Read, understand, and follow all instructions on the machine and in the manual(s) before attempting to assemble and operate this unit. Keep this manual in a safe place for future and regular reference and for ordering replacement parts.
2. Be familiar with all controls and their proper operation. Know how to stop the machine and disengage them quickly.
3. Never allow children under 14 years old to operate this machine. Children 14 years old and over should read and understand the operation instruction and safety rules

in this manual and should be trained and supervised by parent.

4. Never allow adults to operate this machine without proper instruction.
5. Thrown objects can cause serious personal injury. Plan your snow-throwing pattern to avoid discharge of material toward roads, bystanders and the like.
6. Keep bystanders, helpers, pets and children at least 75 feet from the machine while it is in operation. Stop machine if anyone enters the area.
7. Exercise caution to avoid slipping or falling, especially when operating in reverse.

### Preparation for use

1. Thoroughly inspect the area where the equipment is to be used. Remove all doormats, newspapers, sleds, boards, wires and other foreign objects, which could be tripped over or thrown by the auger/impeller.
2. Always wear safety glasses or eye shields during operation and while performing an adjustment or repair to protect your eyes. Thrown objects which ricochet can cause serious injury to the eyes.
3. Do not operate the equipment without wearing adequate winter garments. Avoid loose fitting clothing that can get caught in moving parts. Do not wear jewelry, long scarves or other loose clothing, which could become entangled in moving parts. Wear footwear which will improve footing on slippery surfaces.
4. Use a grounded three-wire extension cord and receptacle for all units with electric start engines.
5. Adjust collector housing height to clear gravel or crushed rock surfaces.
6. Disengage all clutches and shift into neutral before starting the engine.
7. Never attempt to make any adjustments while engine is running, except where specifically recommended in the operator's manual.
8. Let engine and machine adjust to outdoor temperature before starting to clear snow.

### Electrical Safety

1. **NOTE:** Use an extension cord recommended for outdoor use that is not longer than 50 feet (15 m).

**The electrical cord can become damaged, causing a shock or fire. Thoroughly**

**inspect the electrical cord before plugging it into a power source. If the cord is damaged, do not use it to start the snow thrower. Replace or repair the damaged cord immediately. Contact an Authorized Service Dealer for assistance.**

2. Ground fault circuit interrupter (GFCI) protection should be provided on the circuit(s) or outlet(s) to be used for the pole chain saw. Receptacles are available having built-in GFCI protection and may be used for this measure of safety.
3. To prevent electric shock, use only with an extension cord suitable for outdoor use, such as SW-A, SOW-A, STW-A, STOW-A, SJW-A, SJOW-A, SJTW-A, or SJTOW-A. Before use, check that the extension cord is in good condition. When using an extension cord, make sure to use one heavy enough to carry the current your product will draw. For lengths less than 50 ft. (15 m), a No.16 AWG (or greater) extension cord should be used. An undersized cord will cause a drop in line voltage resulting in loss of power and overheating.
4. To reduce the risk of electric shock, this appliance has a polarized plug (i.e. one blade is wider than the other). Use this appliance only with a polarized UL-, CSA- or ETL-rated extension cord for outdoor, all-weather use. The appliance power socket will fit into a polarized extension cord only one way.

### WARNING!

**Electric shock may cause SEVERE INJURY or DEATH. Heed these warnings:**

- Do not allow any part of the machine to make contact with water while it is in operation. If the appliance becomes wet while turned off, wipe dry before starting.
- Use only a UL-, CSA- or ETL-rated extension cord for outdoor, all-weather use.
- Do not use an extension cord over 50 ft (15 m).
- Do not touch the appliance or its plug with wet hands

Cord Length:	50 ft (15 m)
Min. Wire Gauge (A.W.G.):	16

---

## Safe handling of gasoline

To avoid personal injury or property damage use extreme care in handling gasoline. Gasoline is extremely flammable and the vapors are explosive. Serious personal injury can occur when gasoline is spilled on yourself or your clothes, which can ignite. Wash your skin and change clothes immediately.

Use only an approved gasoline container.

1. Use only an approved gasoline container.
2. Extinguish all cigarettes, cigars, pipes and other sources of ignition.
3. Fill fuel tank outdoors with extreme care. Never fill fuel tank indoors.
4. Never remove gas cap or add fuel while the engine is hot or running.
5. Allow engine to cool at least two minutes before refueling.
6. Never over fill fuel tank. Fill tank to no more than 1/2 inch below bottom of filler neck to provide space for fuel expansion.
7. Never fill containers inside a vehicle or on a truck or trailer bed with a plastic liner. Always place containers on the ground, away from your vehicle, before filling.
8. When practical, remove gas-powered equipment from the truck or trailer and refuel it on the ground. If this is not possible, then refuel such equipment on a trailer with a portable container, rather than from a gasoline dispenser nozzle.
9. Keep the nozzle in contact with the rim of the fuel tank or container opening at all times, until refueling is complete. Do not use a nozzle lock-open device.
10. Replace gasoline cap and tighten securely.
11. If gasoline is spilled, wipe it off the engine and equipment. Move machine to another area. Wait 5 minutes before starting the engine.
12. Never store the machine or fuel container inside where there is an open flame, spark or pilot light (e.g. furnace, water heater, space heater, clothes dryer etc.)
13. Allow machine to cool at least 5 minutes before storing.
14. If fuel is spilled on clothing, change clothing immediately.

## Operating Tips

1. Do not put hands or feet near rotating parts, in the auger/impeller housing or chute

assembly. Contact with the rotating parts can amputate hands and feet. Keep clear of the discharge opening at all times.

2. After striking a foreign object, stop the engine (motor), remove the wire from the spark plug, disconnect the cord on electric motors, thoroughly inspect the snow thrower for any damage, and repair the damage before restarting and operating the snow thrower.
3. Stop the engine (motor) whenever you leave the operating position, before unclogging the collector/impeller housing or discharge chute, and when making any repairs, adjustments or inspections.
4. When cleaning, repairing or inspecting the snow blower, stop the engine and make certain the collector/impeller and all moving parts have stopped. Disconnect the spark plug wire and keep the wire away from the plug to prevent someone from accidentally starting the engine
5. The auger/impeller control lever is a safety device. Never bypass its operation. Doing so makes the machine unsafe and may cause personal injury.
6. The control levers must operate easily in both directions and automatically return to the disengaged position when released.
7. Never operate the snow thrower without proper guards, and other safety protective devices in place and working.
8. Never run an engine indoors or in a poorly ventilated area. Engine exhaust contains carbon monoxide, an odorless and deadly gas.
9. Do not operate machine while under the influence of alcohol or drugs.
10. Exercise extreme caution when operating on or crossing gravel surfaces. Stay alert for hidden hazards or traffic.
11. Exercise caution when changing direction and while operating on slopes.
12. Plan your snow-throwing pattern to avoid discharging towards windows, walls, cars etc. Thus, avoiding possible property damage or personal injury caused by a ricochet.
13. Never direct the discharge toward people or areas where property damage can occur. Keep children and others away.
14. Do not overload machine capacity by attempting to clear snow at too fast of a rate.
15. Never operate this machine without good visibility or light. Always be sure of your

- footing and keep a firm hold on the handles. Walk, never run.
16. Disengage power to the auger/impeller when transporting or not in use.
  17. If the machines should start to vibrate abnormally, stop the engine, disconnect the spark plug wire and ground it against the engine. Inspect thoroughly for damage. Repair any damage before starting and operating.
  18. Disengage all control levers and stop engine before you leave the operating position (behind the handles). Wait until the auger/impeller comes to a complete stop before unclogging the chute assembly, making any adjustments, or inspections.
  19. Never put your hand in the discharge or collector openings. Always use the clean-out tool provided to unclog the discharge opening. Do not unclog chute assembly while engine is running. Shut off engine and remain behind handles until all moving parts have stopped before unclogging.
  20. Use only attachments and accessories approved by the manufacturer (e.g. wheel weights, tire chins, cabs etc.).
  21. Never touch a hot engine or muffler
  22. If situations occur which are not covered in this manual, use care and good judgment. Contact your Service Center for assistance.

### **Clearing a Clogged Discharge Chute**

Hand contact with the rotating impeller inside the discharge chute is the most common cause of injury associated with snow throwers. Never use your hand to clean out the discharge chute.

#### **To clear the chute:**

1. SHUT THE ENGINE OFF!
2. Wait 10 seconds to be sure the impeller blades have stopped rotating.
3. Always use a clean-out tool, not your hands.

### **Maintenance & Storage**

1. Never tamper with safety devices. Check their proper operation regularly. Refer to the maintenance and adjustment sections of this manual.
2. Before cleaning, repairing, or inspecting machine disengage all control levers and stop the engine. Wait until the auger/impeller come to a complete stop. Disconnect the spark plug wire and ground against the

3. engine to prevent unintended starting.
3. Check bolts and screws for proper tightness at frequent intervals to keep the machine in safe working condition. Also, visually inspect machine for any damage.
4. Do not change the engine governor setting or over-speed the engine.
5. Snow thrower shave plates and skid shoes are subject to wear and damage. For your safety protection, frequently check all components and replace with original equipment manufacturer's (OEM) parts only. "Use of parts which do not meet the original equipment specifications may lead to improper performance and compromise safety!"
6. Check controls periodically to verify they engage section in this operator's manual for instructions.
7. Maintain or replace safety and instruction labels, as necessary.
8. Never store the machine with fuel in the fuel tank inside a building where ignition sources are present such as hot water heaters, space heaters, or clothes dryers. Allow the engine to cool before storing in any enclosure.
9. Observe proper disposal laws and regulations for gas, oil, etc. to protect the environment.
10. Prior to storing, run machine a few minutes to clear snow from machine and prevent freeze up of auger/impeller.
11. Never store the machine or fuel container inside where there is an open flame, spark or pilot light such as a water heater, furnace, clothes dryer etc.
12. Always refer to the operator's manual for proper instructions on off-season storage.
13. If you need to change the belts, please contact the distributor or local agent. Do not change them by yourself.

#### **Do not modify engine**

To avoid serious injury or death, do not modify engine in any way. Tampering with the governor setting can lead to a runaway engine and cause it to operate at unsafe speeds. Never tamper with factory setting of engine governor.



#### **Residual risks**

**Even when the machine is used as prescribed it is not possible to eliminate all residual risk factors. The following hazards may arise in**

### connection with the machine's construction and design:

- Damage to lungs if an effective dust mask is not worn.
- Damage to hearing if effective hearing protection is not worn.
- Damages to health resulting from vibration emission if the machine is being used over longer period of time or not adequately managed and properly maintained.

**WARNING!** This machine produces an electromagnetic field during operation. This field may under some circumstances interfere with active or passive medical implants. To reduce the risk of serious or fatal injury, we recommend persons with medical implants to consult their physician and the medical implant manufacturer before operating this machine.

The declared vibration total value has been measured in accordance with a standard test method and may be used for comparing one tool with another.

The declared vibration total value may also be used in a preliminary assessment of exposure.

**WARNING!** The vibration emission during actual use of the power tool can differ from the declared total value depending on the ways in which the tool is used.

There is the need to identify safety measures to protect the operator that are based on an estimation of exposure in the actual conditions of use (taking account of all parts of the operating cycle such as the times when the tool is switched off and when it is running idle in addition to the trigger time).

## PACKAGE CONTENTS

### Unpacking

1. Set the shipping carton on a solid, flat surface.
2. Remove everything from the carton except the snow blower base—including carton cover, carton fence, upper handles, drive control rod, chute, etc.
3. Lift the carton fence out of the snow blower base to allow a flat surface area to install the

assembly parts. Make sure all the assembly parts are included before you start.

4. Now you are ready for assembly, then pull away the snow blower from the pallet for operation.

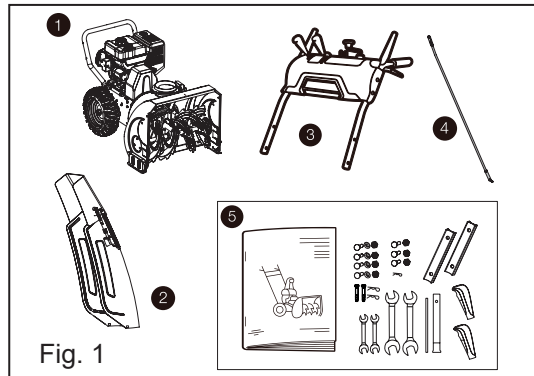

1. Main body of snowblower \*1pc
2. Chute assembly \*1pc
3. Upper handle assembly \*1pc
4. Drive control rod \*1pc
5. Components(see above)
  - a) Fixing bolt, nut & washer \*4pcs
  - b) Fixing bolt & nut \*3pcs
  - c) Fixing bracket \*2pcs
  - d) Spare shear pins \*2pcs
  - e) Spanner \*4pcs
  - f) Spark plug wrench \*1pc
  - g) Knob \*2pcs
  - h) Spare B Pin \*2pcs
  - i) Users manual

## ASSEMBLY

### STEP ONE: Install the upper handle

- (1) Attach the left cable (A, Fig.2) on the upper handle to cable (B, Fig.2) out from the transmission box, while the right cable (C, Fig.2) to the support (D, Fig.2).

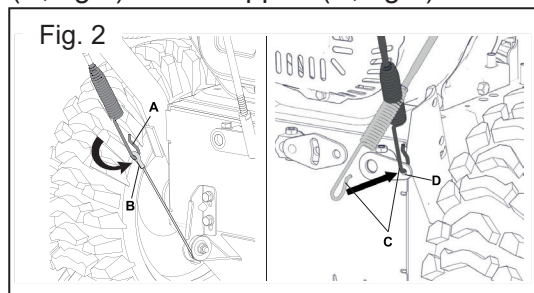

- (2) Attach the upper handle to the lower handle with fixing bolt, nut & washer supplied, with fixing bracket (C, Fig.3) in between two handles (A, B, Fig.3), then tighten by wrench

supplied.

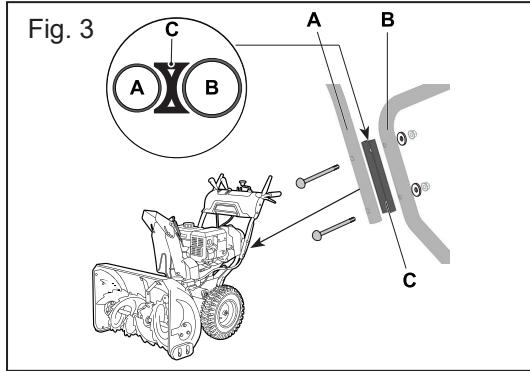

### STEP TWO: Assemble the drive control rod

- 1) Insert the angle side (A, Fig. 4) of drive control rod into the hole on the lever (B, Fig. 4) to connect it to the transmission, and secure it in place with the nut.
- 2) Attach the nose end of the control rod (D, Fig. 4) to the pin on the bottom part of the gear lever (E, Fig. 4), and secure it in place with the B pin.

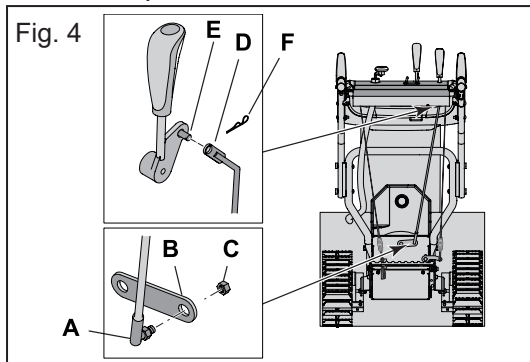

### STEP THREE: Assemble the soft shaft

Plug the soft shaft on the side of rotator from the dashboard, then rotate it tight to fix it (Fig. 5).

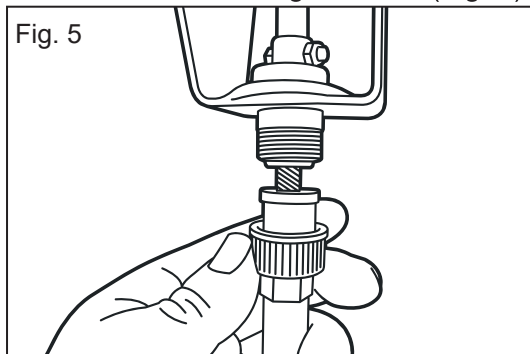

### STEP FOUR: Assemble the control handle knobs

Screw the control handle knobs to the handles on the panel. Make the control handle knobs are in the proper direction, then screw the nuts to fix the knobs. (Fig. 6)

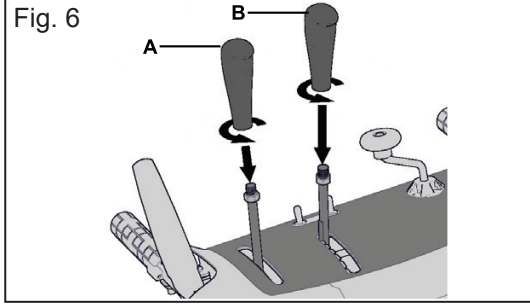

### STEP FIVE: Assemble the chute

- 1) Place the chute on the chute seat, fix it with carriage bolts inside and nuts outside. (Fig. 7).
- 2) Before insert chute cap control cable end (C, Fig. 8) in position, release the two screws A (Fig. 8). Secure it to the bar (B, Fig. 8) with a B pin (D, Fig. 8), then tighten the two screws to the base (E, Fig. 8) to secure the cable. Press the cable onto the guider (A, Fig. 9) for affixing.

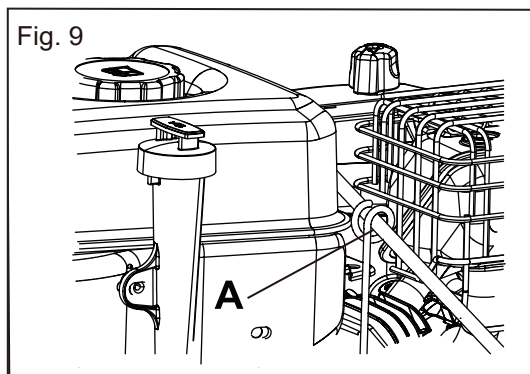
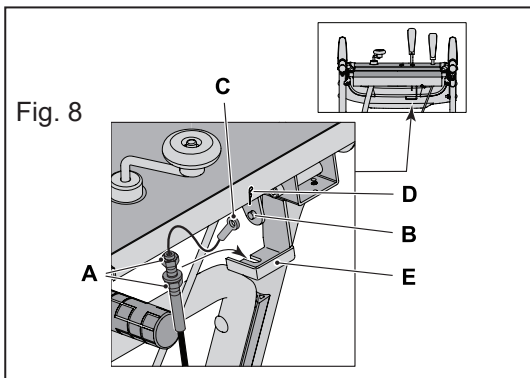
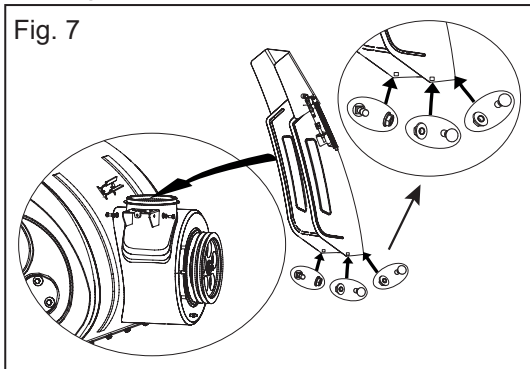

**KNOW YOUR 24" GAS SNOWBLOWER (FIG.10)**

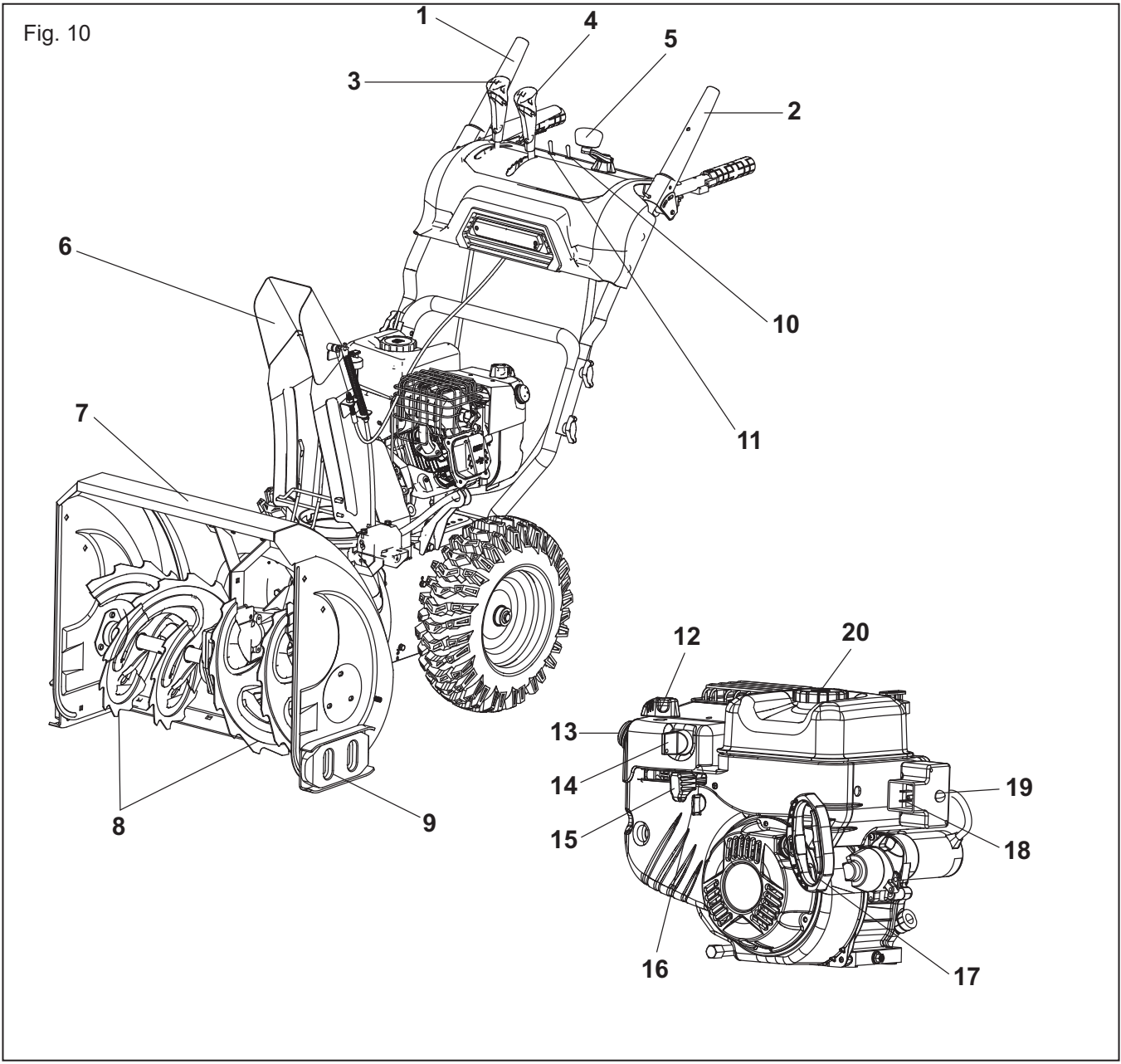

- |                                      |                             |
|--------------------------------------|-----------------------------|
| 1. Auger Control                     | 11. Heating handle switch   |
| 2. Drive Control                     | 12. Choke control lever     |
| 3. Shift Lever / Speed Control       | 13. Primer                  |
| 4. Chute deflector control lever     | 14. Ignition key            |
| 5. Chute direction control joystick  | 15. Throttle control lever  |
| 6. Chute Assembly                    | 16. Fuel valve lever        |
| 7. Auger housing with clean-out tool | 17. Recoil starter handle   |
| 8. Auger                             | 18. Electric outlet         |
| 9. Skid Shoes (plastic + steel)      | 19. Electric starter button |
| 10. LED headlight switch             | 20. Fuel tank cap           |

## BEFORE OPERATION

### Check The General Condition

1. Look around and underneath the engine for signs of oil or gasoline leaks.
2. Remove any excessive dirt or debris, especially around the muffler and recoil starter.
3. Look for signs of damage.
4. Check that all shields and covers are in place, and all nuts, bolts, and screws are tightened.

### Check The Engine

1. There is no fuel or oil in the engine. Fill with fuel and add 5W-30 prior to first use. (see "maintenance")
2. Check the fuel level.
3. Check the oil level.

## OPERATION

### Starting The Engine

1. Attach spark plug wire to spark plug. Make certain the metal loop on the end of the spark plug wire (inside the rubber boot) is fastened securely over the metal tip on the spark plug.
2. Make certain both the auger control and drive control are in the disengaged (released) position.
3. Move throttle control to FAST (rabbit) position. Insert ignition key into slot. Make sure it snaps into place. Do not attempt to turn the key.
4. Make sure fuel valve lever is in the ON position.

**NOTE:** The engine cannot start without the key is fully inserted into the ignition switch.

### Electric Starter

Determine that your home's wiring is a two-wire grounded system. Ask a licensed electrician if you are not certain.

**WARNING:** The optional electric starter is equipped with a grounded two-wire power plug, and is designed to operate on 120 volt AC household current. It must be used with a properly grounded two-prong receptacle at all times to avoid the possibility of electric shock. If your home's wiring system is not a grounded

system, do not use this electric starter under any conditions.

If your home electrical system is grounded, but a two-hole extension cord is not available, do not use your snow blower's electric starter.

Follow all instructions carefully prior to operating the electric starter.

If you have all of the above, proceed as follows:

- 1) Plug the extension cord into the outlet located on the engine's surface. Plug the other end of extension cord into a 120-volt, grounded, AC outlet in a well-ventilated area.
- 2) Place choke control to FULL choke position (for a cold engine start).

**NOTE:** If the engine is already warm, place choke control in the OFF position instead of FULL.

- 3) Push the primer two or three times for cold engine start, , marking sure to cover vent hole in the center of the primer when pushing.

**NOTE:** DO NOT use primer to restart a warm engine after a short shutdown.

- 4) Push start button to start engine.
- 5) Once the engine starts, release starter button.
- 6) AS the engine warms, slowly rotate the choke control to the OFF position. if the engine falters, quickly rotate the choke control back to FULL and then slowly into the OFF position again.
- 7) When disconnecting the extension cord, always unplug the end at the wall outlet then unplug the opposite end from the snowblower.

### Recoil Starter



1. Rotate choke control to FULL choke position (cold engine start).

**NOTE:** If the engine is already warm, place choke control in the OFF position instead of FULL.

2. Push the primer two or three times for cold engine start, making sure to cover vent hole in the center of the primer when pushing.

**NOTE:** DO NOT use primer to restart a warm engine after a short shutdown.

**NOTE:** Additional priming maybe necessary if the temperature is below -10°.

3. Grasp the recoil starter handle and slowly pull the rope out. At the point where it becomes slightly harder to pull the rope, slowly allow the rope to recoil.
4. Pull the starter handle with a firm, rapid stroke. Do not release the handle and allow it to snap back. Keep a firm hold on the starter handle and allow it to slowly recoil.
5. As the engine warms, slowly rotate the choke control to the OFF position. If the engine falters, quickly rotate the choke control back to the FULL position and then slowly into the OFF position again.

**NOTE:** Allow the engine to warm up for a few minutes after starting. The engine will not develop full power until reaching operating temperatures.

### Stopping The Engine

Run engine for a few minutes before stopping to help dry off any moisture on the engine.

To help prevent possible starter freeze-up, proceed as follows:

#### Electric Starter

1. Connect extension cord to the electric starter outlet on the engine, then to 120 volt AC outlet.
2. With the engine running, push the starter button and allow the starter to spin for several seconds. The noise made in the starter is normal. The engine's starter is not being harmed.
3. When disconnecting the extension cord, always unplug the end at the wall outlet before unplugging the opposite end from the snowblower.
4. Move throttle control to STOP (tortoise) position.
5. Remove the ignition key and store in a safe place.
6. Wipe all snow and moisture from the area around the engine as well as the area in and around the drive control and auger control. Also, engage and release both controls several times.

#### Recoil Starter

1. With engine running, pull the starter rope with a rapid, continuous full arm stroke three or four times. Pulling the starter rope will produce a loud clattering sound, which is not

- harmful to engine.
2. Move throttle control to STOP (tortoise) position.
3. Remove the ignition key and store in a safe place.
4. Wipe all snow and moisture from the area around the engine as well as the area in and around the drive control several times

### OPERATING YOUR SNOWBLOWER

**WARNING:** Read, understand, and follow all instructions and warnings on the machine and in this manual before operating.

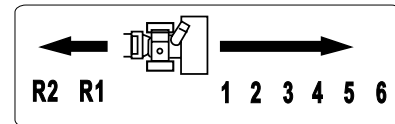

Fig. 11

The shift lever is located between the upper handles. Place the shift lever into any of 8 positions to control the direction of travel and ground speed. (See Figure 11)

#### Forward

There are six forward (F) speeds. Position one (1) is the slowest and position six (6) is the fastest.

#### Reverse

There are two reverse (R) speeds. One (R1) is the slower and the other (R2) is the faster.

#### Primer

Depressing the primer forces fuel directly into the engine's carburetor to aid in cold-weather starting.

#### Choke Control

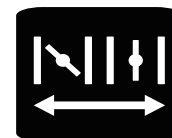

Fig. 12

The choke control is found on the rear of the engine and is activated by rotating the knob clockwise to FULL position and counterclockwise to OFF position. Activating the choke control closes the choke plate on the carburetor and aids in starting the engine. See Fig. 12.

## Throttle Control

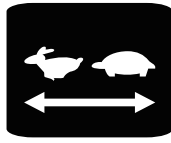

Fig. 13

The throttle control is located on the engine. It regulates the speed of the engine and will shut off the engine when pushed down to the end (tortoise) completely. (See Fig.13)

## Auger Control

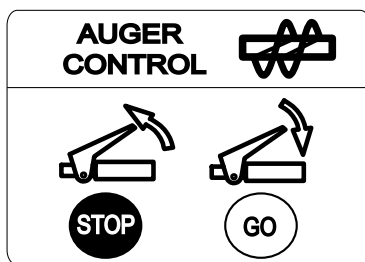

Fig. 14

The auger control is located on the right handle. Squeeze the control grip against the handle to engage the augers and start snow throwing action. Release to stop. See Figure 14.

## Drive Control

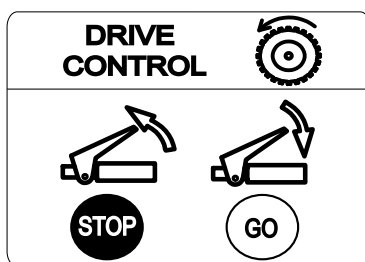

Fig. 15

The drive control is located on the left handle. Squeeze the control grip against the handle to engage the wheel drive. Release to stop. See (See Fig.15.)

This snow blower has EXCLUSIVE Simultaneous Engagement System for one-hand operation and Built-in auto-turn power steering system, this technology enables effortless power steering on your snowblower. This system is able to sense the direction your trying to turn the snowblower and engages the drive system to assist turning in the desired direction.

## Chute Directional Control

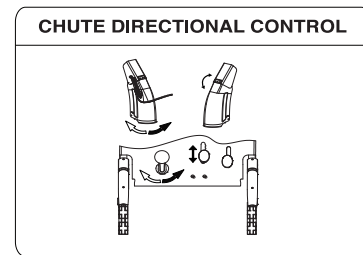

Fig. 16

The chute directional control is located on the panel of the snowblower. To change the direction in which snow is thrown, turn chute directional control as follows: Crank control joystick clockwise to discharge to the right. Crank control joystick counterclockwise to discharge to the left.(See Fig. 16).

## Chute Deflector (Up/Down control lever)

Manually operate the control lever forward and backward. The more backward the position, the higher the height of snow is thrown.(See Fig.16)

## LED Headlight Switch

Located on control panel. Turn ON to illuminate the headlight LED and OFF to douse.

## Heating Handle Switch

located on control panel. Turn ON to heat both operation handles and OFF to stop.

## Skid Shoes

Position the skid shoes based on surface conditions. Adjust upward for hard-packed snow. Adjust downward when operating on gravel or crushed rock surfaces.This machine is equipped with plastic and steel skid shoes for different surface.

## Recoil Starter Handle

This handle is used to manually start the engine.

## Electric Starter Outlet

 Requires the use of a two-prong outdoor extension cord and a 120V power source.

**NOTE:** This machine is not equipped with an extension cord.

## Augers

When engaged, the augers rotate and draw snow into the auger housing.

## Chute Assembly

Snow drawn into the auger housing is discharged out through the chute assembly.

## Chute Clean-Out Tool

The chute clean-out tool is conveniently fastened to the rear of the auger housing with a mounting clip. Should snow and ice become clogged in the chute assembly during operation, proceed as follows to safely clean the chute assembly and chute opening.

1. Release both the Auger Control and the Drive Control.
2. Stop the engine by removing the ignition key.
3. Remove the clean-out tool from the clip which secures it to the rear of the auger housing. .



**WARNING: The muffler, engine and surrounding areas become hot and can cause a burn. DO not touch.**

4. Use the shovel-shaped end of the clean-out tool to dislodge and scoop any snow and ice which has formed in and near the chute assembly.
5. Refasten the clean-out tool to the mounting clip on the rear of the auger housing, reinsert the ignition key and start the snow thrower's engine.
6. While standing in the operator's position (behind the snow thrower), engage the auger control for a few seconds to clear any remaining snow and ice from the chute assembly.

## To Engage Drive

1. With the throttle control in the Fast (rabbit) position, move shift lever into one of the six forward (F) positions or two reverse (R) positions. Select a speed appropriate for the snow conditions and a pace you're comfortable with.

**NOTE:** When selecting a Drive Speed, use the slower speed until you are comfortable and familiar with the operation of the snowblower.

2. Squeeze the auger control against the handle and the auger will turn. Release it and the augers will stop.

3. Squeeze the drive control against the handle and snow thrower will move. Release it and drive motion will stop.

**IMPORTANT: NEVER reposition the shift lever (change speeds or direction of travel) without first releasing the drive control and bringing the snow thrower to a complete stop. Doing so will result in premature wear to the snow blower drive system.**

## MAINTENANCE

### Gas Cap

Unthread the gas cap to add gasoline to the fuel tank.

### Gasoline



**WARNING: Use extreme care when handling gasoline is extremely flammable and the vapors are explosive. Never fuel the machine indoors or while the engine is hot or running. Extinguish cigarettes, cigars, pipes and other sources of ignition.**

- Store gasoline in a clean, approved container and keep the cap in place on the container.
- Make sure that the container from which you pour the gasoline is clean and free from rust or other foreign particles.

### Oil Fill

Engine oil level can be checked and oil added through the oil fill.

### Before Starting Engine

Do not start the engine until filled with oil. The engine can be seriously damaged without oil .

1. Place the machine on a level floor.
2. Loosen the dipstick and read the oil level.
3. The oil level shall be between the marks "HIGH" and "LOW". (See FIG.17).
4. It necessary fill with oil up to the HIGH mark (See FIG.17).
5. Use good quality oil marked A.P.I. service SF, SG or SH.

Use SAE 5W30 oil. Use SAE 0W30 oil for temperatures under -18 °C

Do not use SAE 10W40.

Fig. 17

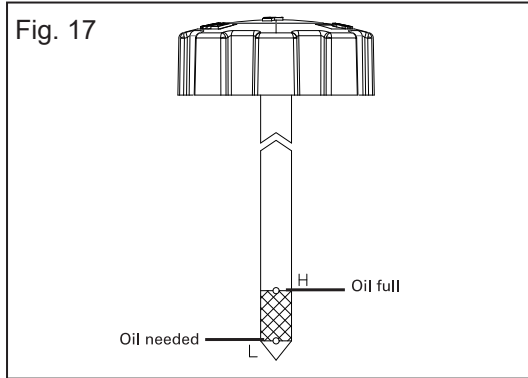

## Lubrication

**WARNING:** Before lubricating, repairing, or inspecting, disengage all controls and stop engine. Wait until all moving parts have come to a complete stop.

## Gear Shaft

The gear (hex) shaft (FIG.18A) should be lubricated at least once a season or after every 25 hours of operation.

1. Remove the lower frame cover by removing the two screws which secure it.
2. Apply a light coating of an all-weather multi-purpose grease to the hex shaft. (See FIG.18).

Fig. 18

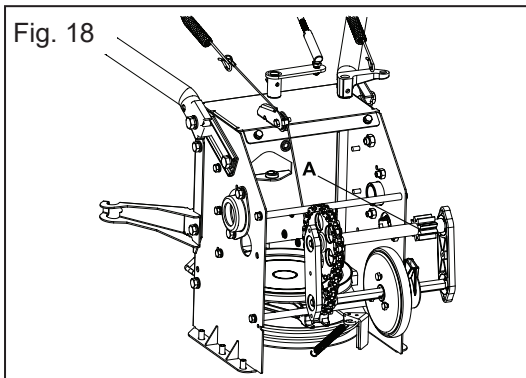

**IMPORTANT:** Avoid oil spillage on rubber friction

## Wheels

At least once a season, remove both wheels. Clean and coat the axles with a multipurpose automotive grease before reinstalling wheels.

## Auger Shaft

At least once a season, remove the shear pins on auger shaft. Spray lubricant inside shaft, around the spacers. Also lubricate the flange bearings found at either end of the shaft. (See Fig.19).

Fig. 19

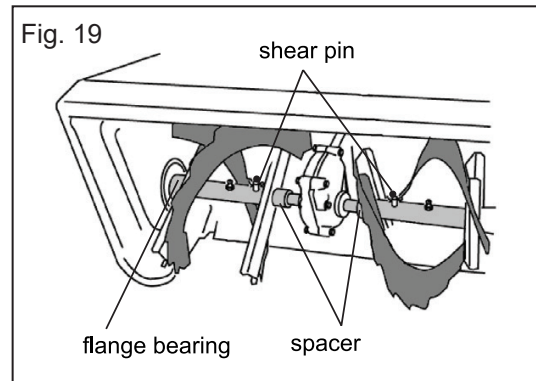

## Gear Case

The auger gear case has been filled with grease and sealed at the factory. If disassembled from any reason, lubricate with 160g of new grease.

**NOTE:** Do not over fill the gear case. Damage to the seals could result. Be sure the vent plug is free of grease in order to relieve pressure.

## Shave Plate and Skid Shoes

The shave plate and skid shoes on the bottom of the snowblower are subject to wear. They should be checked periodically and replaced when necessary.

### To remove skid shoes:

1. Remove the four carriage bolts and hex flange nuts which secure them to the snowblower. (See Fig. 20)
2. Reassemble new skid shoes with the four carriage bolts (two on each side) and hex flange nuts. (See Fig.20).

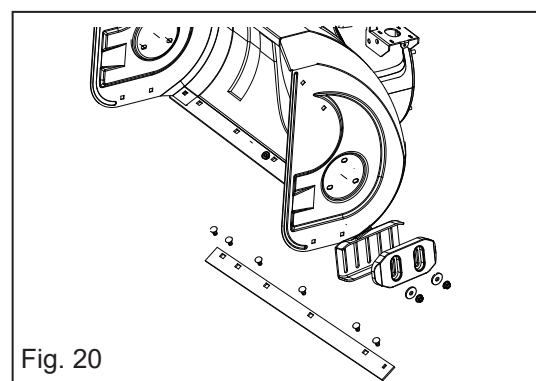

### To remove shave plate:

1. Remove the carriage bolts and hex nuts which attach it to the snowblower housing.
2. Reassemble new shave plate, making sure heads of carriage bolts are to the inside of

housing and the new shave plate is 2-4 mm above the ground. Tighten securely.

### Auger Belt Replacement

To remove and replace your snowblower's auger belt, proceed as follows:

1. Remove the belt cover on the front of the engine by removing the two self-tapping screws. (See Fig.21).

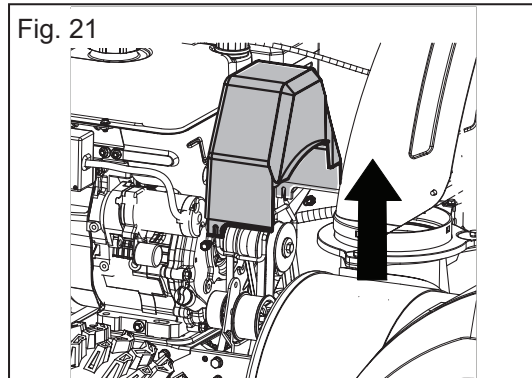

**NOTE:** Drain the gasoline from the snowblower, or place of plastic under the gas cap.

2. Carefully pivot the snow thrower up and forward so that it rests on the auger housing. Remove the frame cover from the underside of the snowblower by removing four self-tapping screws which secure it. (See Fig.22).

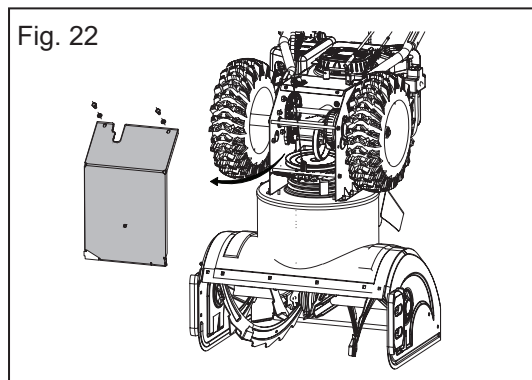

3. Loosen and remove the shoulder screw of the belt keeper. (See Fig.23).

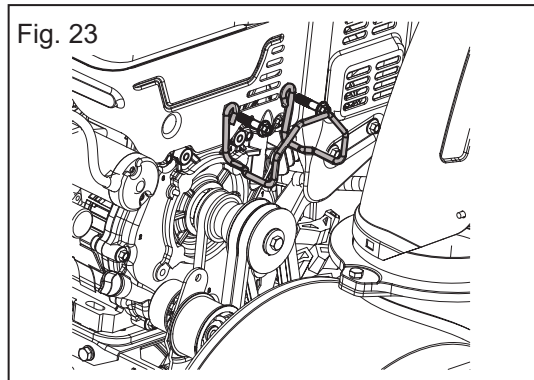

- 4A. Roll the auger belt off the engine pulley (See Fig.24A)
- 4B. Unhook the support bracket spring from the frame (See Fig.24B)

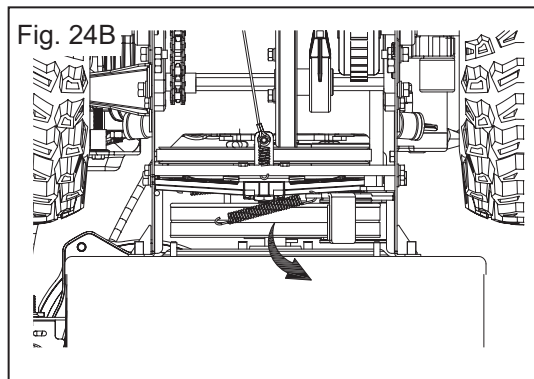
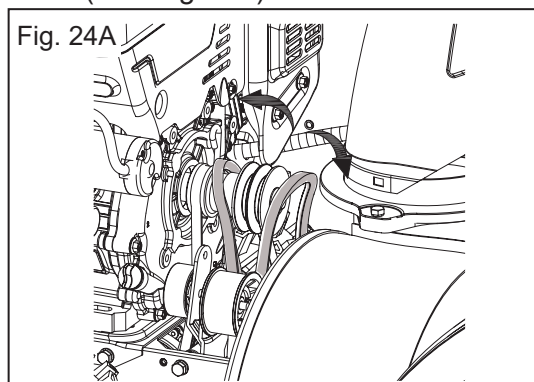

5. Remove the belt from around the auger pulley, and slip the belt between the support bracket and the auger pulley. Reassemble auger belt by above instructions in reverse order. (See Fig.25).

Fig. 25

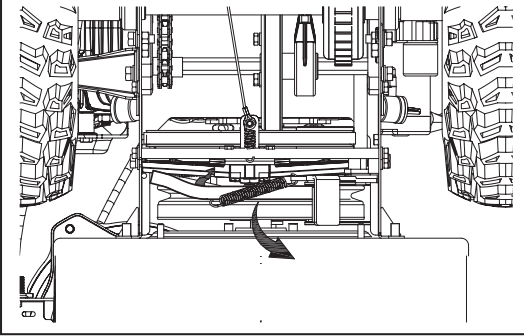

**NOTE:** Do NOT forget to reinstall the shoulder screw and reconnect the spring to the frame after installing a replacement auger belt.

### Augers

- The auger are secured to the spiral shaft with two shear pins and cotter pins. If the auger should strike a foreign object or ice jam, the snowblower is designed so that the pins may shear. (See Fig. 26)
- If the augers will not turn, check to see if the pins have sheared. One set of replacement shear pins has been provided with the snowblower. When replacing pins, spray an oil lubricant into shaft before inserting new pins.

Fig. 26

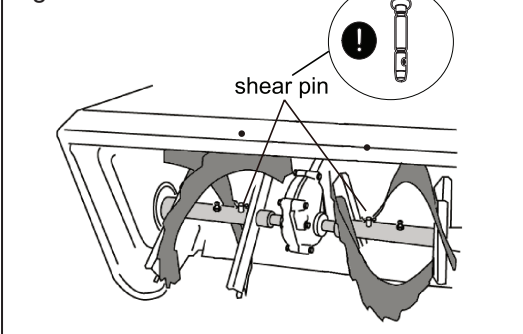

### Drive Belt Replacement

To remove and replace your snowblower's auger belt, proceed as follows:

1. Remove the belt cover in the front of the engine by removing the two self-tapping screws. (See Fig.27).

Fig. 27

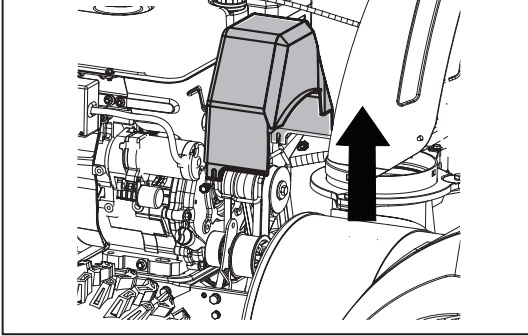

**NOTE:** Drain the gasoline from the snow thrower or place a piece of plastic under the gas cap.

2. Carefully pivot the snow thrower up and forward so that it rests on the auger housing. Remove the frame cover from the underside of the snowblower by removing four self tapping screws which secure it. (See Fig. 28)

Fig. 28

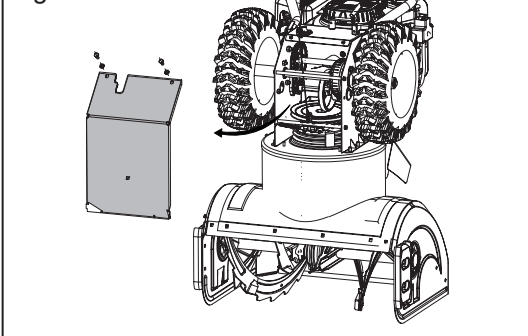

- 3A. Loosen and remove the shoulder screw of the belt keeper(see Fig.24A).
- 3B. Roll the two anger belts off the engine pulley,see section "AUGER BELT REPLACEMENT".
- 3C. Then lifr the drive belt off engine pulley.(See Fig.29)

Fig. 29

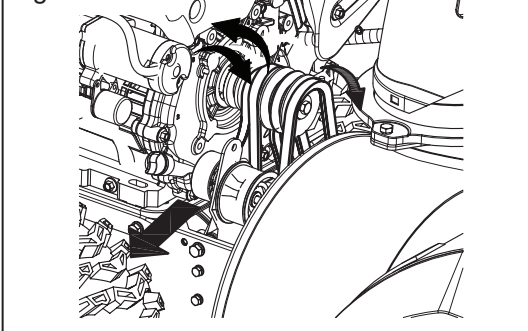

4. Slip the drive belt off the pulley and between friction wheel and friction wheel disc. (See Fig.30).

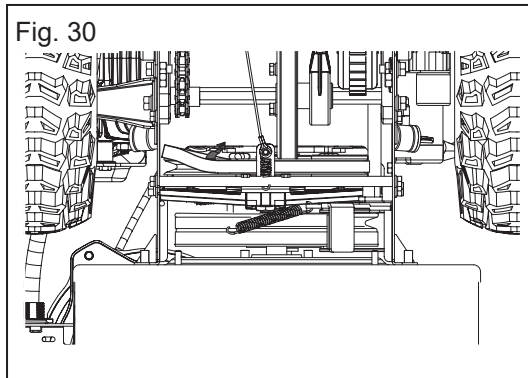

5. Replace belt in the reverse order.

### Friction Wheel Removal

If the snowblower fails to drive with the drive control engaged, and performing the drive control cable adjustment fails to correct the problem, the friction wheel may need to be replaced. Follow the instructions below.

1. Examine the friction wheel for signs of wear or cracking and replace if necessary.
  - Place the shift lever in third Forward (F3) position.
  - Drain the gasoline from the snowblower, or place a piece of Plastic under the gas cap.
  - Carefully pivot the snow thrower up and forward so that it rests on the auger housing.
- 2A. Remove the frame cover from the underside of the snowblower by removing two self-tapping screws which secure it .
- 2B. Remove the left and right wheels by removing the snap joints on side of wheels . (See Fig.31)

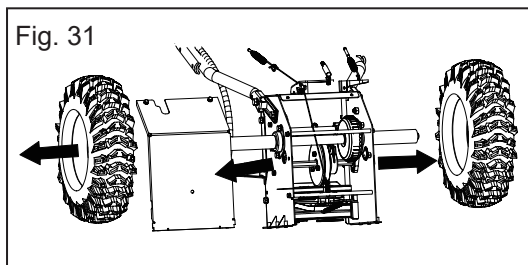

3. Pull out the drive shafts, remove the gear. (See Fig. 32)

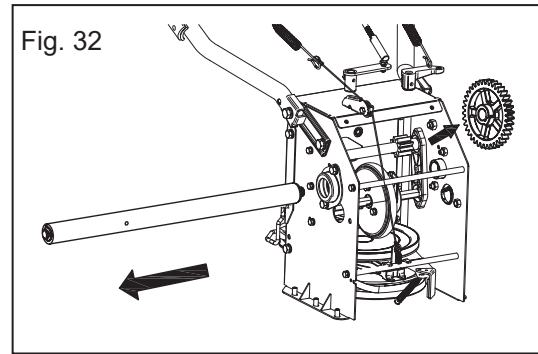

4. Pull the hex shaft by force, remove the hex shaft and transition shaft assembly off. (See Fig.33).

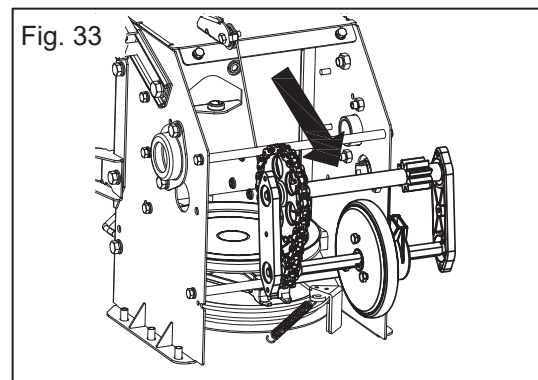

5. Remove the three screws which secure the friction wheel's side plates together. (See Fig. 34).

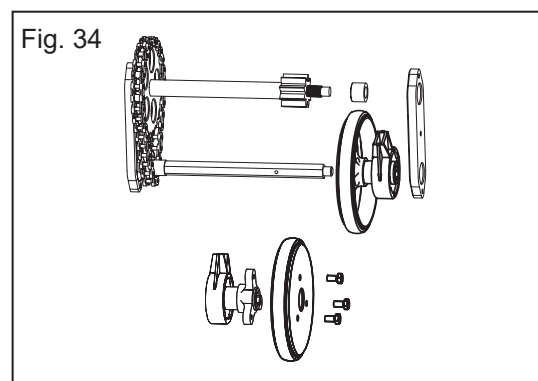

6. Slide the friction wheel assembly back onto the hex shaft and follow the steps above in reverse order to reassemble components.

### CHECKING ENGINE OIL

1. Be sure engine is upright and level.
2. Unscrew oil fill cap from oil filler tube and wipe dipstick clean. (See Fig.35).

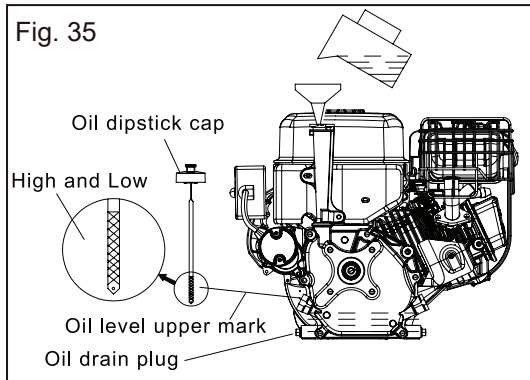

3. Screw oil cap back into oil filler tube. Tighten securely.
4. Unscrew and remove oil fill cap from oil filler tube. Note oil level. If oil reading on dipstick is below "LOW" mark, slowly add oil to reach "HIGH" level, (see Fig.35).
5. Screw oil fill cap back into oil filler tube, tighten securely.
6. Wipe away any spilled oil.

### Changing Engine Oil

To avoid engine damage, it is important to:

- Check oil level before each use and every five operating hours.
  - Change oil after first two operating hours and every 25 operating hours thereafter.
  - Engine should still be warm but not hot from recent use.
1. Locate the oil drain plug, see fig.35.
  2. Be sure the gas cap is on and is tighten securely.
  3. Clean area around oil drain plug, See Fig.35.
  4. Place approved recyclable oil container under oil drain plug.
  5. Remove oil drain plug and drain oil.

**Note:** Used oil must be disposed of at a proper collection center.

6. Install oil drain plug and tighten securely.
7. Refill the engine with recommended oil, see Recommended Oil as Fig.36. Usage chart.

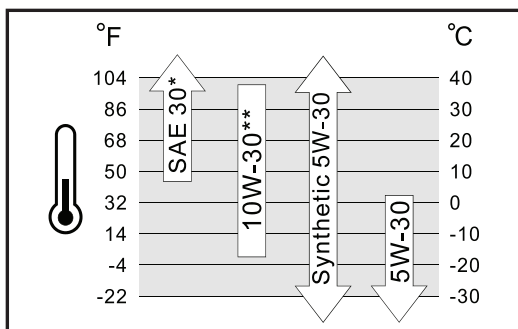

Fig. 36

8. Wipe away any spilled oil.

### Checking Spark Plug

Check spark plug yearly or every 100 operating hours

1. Clean area around spark plug.
2. Remove and inspect spark plug.
3. Replace spark plug if porcelain is cracked or if electrodes are pitted, burned or fouled with deposits.
4. Check electrode gap with a feeler gauge and set gap to 0.030(0.76mm) if necessary. (See Fig.37).

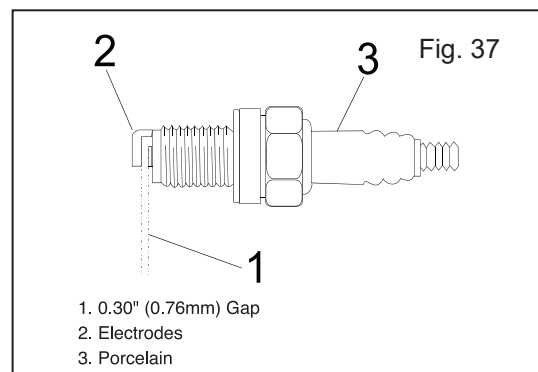

5. Reinstall spark plug and tighten securely
- NOTE:** A resistor spark plug must be used for replacement. Contact the distributor or local agent for a replacement spark plug.

### Carburetor

If you suspect your carburetor needs adjusted, contact the distributor or local agent, engine performance should not be affected at altitudes up to 7000 feet (2134 meters). For operation at higher elevations, contact the distributor or local agent.

### Engine Speed

**WARNING:** Avoid serious injury or death, DO NOT modify engine in any way, Tampering with the governor setting can cause the engine and equipment to operate at unsafe speeds. NEVER tamper with factory setting of engine governor. Running the engine faster than the speed set at the factory is dangerous.

## SERVICE AND ADJUSTMENT

### Control Wire Adjustment

After long time using, or when the belts are adjusted or replaced, the control wires must also adjusted (See Fig.38).

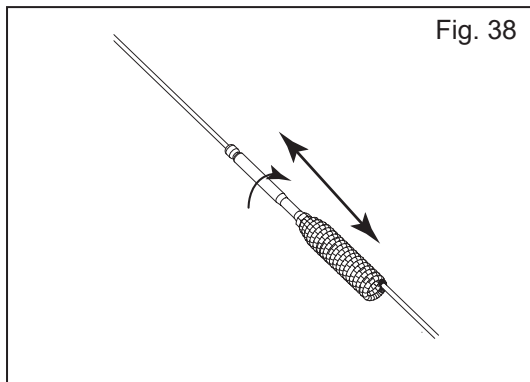

1. Hold the threaded part and adjust the nut or until the correct setting is obtained.

### Skid Shoe Adjustment

The gap between shave plate and ground can be adjusted through skid shoe position(See Fig.39).

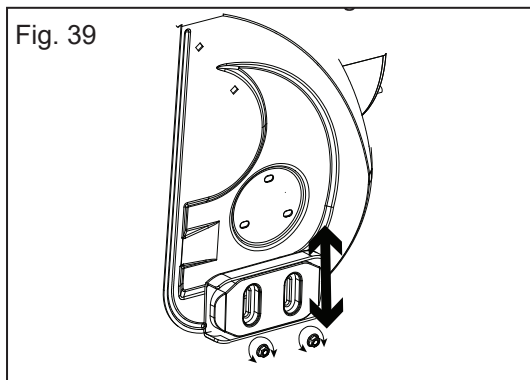

For close snow removal on a smooth surface, raise skid shoes higher on the auger housing.  
Use a middle or lower position when the area to be cleared is uneven, such as a gravel driveway.

### To adjust the skid shoes:

1. Loosen the four hex nuts (Two on each side) and carriage bolts. Move skid shoes to desired position.
2. Make certain the entire bottom surface of skid shoe is against the ground to avoid uneven wear on the skid shoes.
3. Retighten nuts and bolts securely.

### Tire Pressure

Before operating, Check the pressure and reduce pressure to between 15 psi and 20 psi. If the tire pressure is not equal in both tires, the unit may pull to one side or the other.

## OFF-SEASON STORAGE

### Preparing Engine

**WARNING:** Never store snowblower with fuel in tank indoors or in poorly ventilated areas, where fuel fumes may reach an open flame, spark or pilot light as on a furnace, water heater, clothes dryer or gas appliance.

**NOTE:** It is important to prevent gum deposits from forming in essential fuel system parts of the engine such as the carburetor, fuel filter, fuel hose or tank during storage.

**CAUTION:** Alcohol blended fuels (called gasohol or using ethanol or methanol) can attract moisture which leads to separation and formation acids during storage. Acidic gas can damage the fuel system of an engine while in storage.

To avoid engine problems, the fuel system should be emptied before storage for 30 days or longer, Follow these instructions to prepare your snow thrower for storage:

**WARNING: Drain fuel into an approved container outdoors, away from any open flame. Be certain engine is cool. Do not smoke. Fuel left in engine during warm weather deteriorates and will cause serious starting problems.**

1. Remove ALL gasoline from the carburetor and the fuel tank to prevent gum deposits from forming on these parts and harming the engine.
2. Run the engine until the fuel tank is empty and it stops due to lack of fuel.
3. Drain carburetor by pressing upward on bowl drain, located below the carburetor cover.

**WARNING: Do not drain carburetor if using fuel stabilizer. Never use engine or carburetor cleaning products in the fuel tank or permanent damage may occur.**

**NOTE:** Fuel stabilizer (such as STA-BIL) is an acceptable alternative in minimizing the formation of fuel gum deposits during storage. Add stabilizer to gasoline in fuel tank or storage container, Always follow mix ratio found on stabilizer container. Run engine at least 10 minutes after adding stabilizer to allow it to reach the carburetor. Do not drain carburetor if using fuel stabilizer.















4. Remove the spark plug and pour one ounce of engine oil through the spark hole into the cylinder. Cover spark plug hole with a rag and crank the engine several times to distribute the oil. Replace spark plug.

### **Preparing Snowblower**













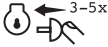

1. When storing the snow thrower in an unventilated or metal storage shed, care should be taken to rustproof the equipment, using a light oil or silicone, coat the equipment, especially any chains, springs, bearings and cables.
2. Remove all dirt from exterior of engine and equipment.
3. Follow lubrication recommendations in the Maintenance section of this manual.
4. Store equipment in a clean dry area.

# SAFETY SYMBOLS

The following symbols may be used on this product. Please study them and learn their meaning. Proper description of these symbols will allow you to operate the product safely.

	To reduce the risk of injury, user must read and understand the instruction manual before operating this product.
	Wear eye protection. Always wear safety goggles or safety glasses with side shields.
	Wear ear protection. Always wear full ear protection when operating this product.
	Electric shock. Failure to use the starter in dry conditions and to observe safe practices can result in electric shock.
	Risk of fire. Fuel and its vapours are extremely flammable and explosive. Fire can cause severe burns or death. Do not add fuel while the product is operating or still hot.
	Toxic Fumes. The engine exhaust from this product contains chemicals known to cause cancer, birth defects and other reproductive harm.
	Risk of asphyxiation. This engine emits carbon monoxide, a colorless, odorless poison gas. Breathing carbon monoxide can cause nausea, fainting or death. Use only in a well-ventilated area.
	Thrown Objects. This machine may pick up and throw objects which can cause serious personal injury.
	Always use chute tool. Never use your hands to clear a clogged chute assemble. Shut OFF engine and remain behind handles until all moving parts have stopped before unlogging.
	Hot surface. Do not touch! Exhaust gases, muffler and engine components are extremely HOT and cause burns.
	Check oil level. Recommended oil is 5W-30. The engine can be seriously damaged without oil. Always check the oil level before use. The machine must be resting firmly on level ground when checking.
	Safe Distance. Bystanders to keep a safe distance.
	Rotating Auger. Danger: Avoid injury from rotating auger. Keep feet away.
	Rotating Parts. Never put your hand in the chute. Contact with rotating parts can amputate fingers and hands.
	Rotating Impeller. Never use your hands to clear a clogged chute assembly. Shut OFF engine and remain behind handles until all moving parts have stopped before unlogging.

## OPERATION SYMBOLS

	Fuel shutoff. Remove the engine key and fuel shutoff.
	Shut off engine and remove key before performing maintenance or repair work.
  	Use clean, fresh, regular unleaded gasoline with a minimum octane rating of 87 and an ethanol content of less than 10% by volume.
	Insert Ignition key.
	Remove Ignition key.
	Cold prime.
	Warm prime.
	Move the fuel valve lever to the "ON" position.
	Move the fuel valve lever to the "OFF" position.
	Move the throttle lever to full speed.
	Lower the speed of the engine.
	Choke opened, when the engine starts, move the choke to "RUN" position.
	Choke closed, to start a cold engine, move the choke lever to the "CHOKE" position.

# TROUBLESHOOTING

See appropriate section in manual unless directed to a service center/department.

PROBLEM	CAUSE	CORRECTION
<b>Does not start</b>	<ol style="list-style-type: none"> <li>1. Safety ignition key is not inserted.</li> <li>2. Out of fuel.</li> <li>3. ON/OFF switch is OFF.</li> <li>4. Choke in OFF position.</li> <li>5. Primer not depressed.</li> <li>6. Engine is flooded.</li> <li>7. Spark plug wire is disconnected.</li> <li>8. Bad spark plug.</li> <li>9. Stale fuel.</li> <li>10. Water in fuel.</li> <li>11. Vapor locked fuel line.</li> </ol>	<ol style="list-style-type: none"> <li>1. Insert safety ignition key.</li> <li>2. Fill fuel tank with fresh, clean gasoline.</li> <li>3. Move ON/OFF switch to ON position.</li> <li>4. Move to FULL position.</li> <li>5. Prime as instructed in the Operation section of this manual.</li> <li>6. Wait a few minutes before restarting, DO NOT prime.</li> <li>7. Connect wire to spark plug.</li> <li>8. Replace spark plug.</li> <li>9. Empty fuel tank &amp; carburetor, refill with fresh, clean gasoline.</li> <li>10. Empty fuel tank &amp; carburetor, refill with fresh, clean gasoline.</li> <li>11. Ensure all the fuel line is below the outlet of the fuel tank. Fuel line should run continuously down from fuel tank to carburetor.</li> </ol>
<b>Loss of power</b>	<ol style="list-style-type: none"> <li>1. Spark plug wire loose.</li> <li>2. Throwing too much snow.</li> <li>3. Fuel tank cap is covered with ice or snow.</li> <li>4. Dirty or clogged muffler.</li> <li>5. Improper cable length.</li> <li>6. Blocked muffler.</li> <li>7. Blocked carburetor air intake.</li> </ol>	<ol style="list-style-type: none"> <li>1. Reconnect spark plug wire.</li> <li>2. Reduce speed and width of swath.</li> <li>3. Remove ice and snow on and around fuel tank cap.</li> <li>4. Clean or replace muffler.</li> <li>5. Adjust cable.</li> <li>6. Clear blockage (ensure engine is cool).</li> <li>7. Clear blockage (ensure engine is cool).</li> </ol>
<b>Engine idles or runs roughly</b>	<ol style="list-style-type: none"> <li>1. Choke is in FULL position.</li> <li>2. Blockage in fuel line.</li> <li>3. Stale fuel.</li> <li>4. Water in fuel.</li> <li>5. Carburetor is in need of replacing</li> <li>6. Belt stretch.</li> </ol>	<ol style="list-style-type: none"> <li>1. Move choke to OFF position.</li> <li>2. Clean fuel line.</li> <li>3. Empty fuel tank &amp; carburetor, refill with fresh, clean gasoline.</li> <li>4. Empty fuel tank &amp; carburetor, refill with fresh, clean gasoline.</li> <li>5. Contact an authorized service center/department.</li> <li>6. Replace auger v-belt.</li> </ol>
<b>Excessive vibration / Handle movement</b>	<ol style="list-style-type: none"> <li>1. Loose parts or damaged augers or impeller.</li> <li>2. Handles not positioned correctly.</li> <li>3. Adjustment lever nuts are loose.</li> </ol>	<ol style="list-style-type: none"> <li>1. Tighten all fasteners. Replace damaged parts. If vibration remains, contact an authorized service center/department.</li> <li>2. Ensure handles are locked into positioning.</li> <li>3. Tighten nuts until handle feels secure.</li> </ol>
<b>Recoil starter is hard to pull</b>	<ol style="list-style-type: none"> <li>1. Frozen recoil starter.</li> <li>2. Rope is interfering with components.</li> </ol>	<ol style="list-style-type: none"> <li>1. See "IF RECOIL STARTER HAS FROZEN" in the Operation section of this manual.</li> <li>2. Recoil rope should not be touching any wires or hoses.</li> </ol>
<b>Loss of snow discharge or slowing of snow discharge</b>	<ol style="list-style-type: none"> <li>1. Worn belt.</li> <li>2. Auger v-belt is off of pulley.</li> <li>3. Auger v-belt is worn.</li> <li>4. Clogged discharge chute.</li> <li>5. Augers / impeller jammed.</li> </ol>	<ol style="list-style-type: none"> <li>1. Adjust drive cable per maintenance procedures.</li> <li>2. Check / reinstall auger v-belt.</li> <li>3. Check / replace auger v-belt.</li> <li>4. Clean snow chute.</li> <li>5. Remove debris or foreign object from augers / impeller.</li> </ol>
<b>Lights not On (If Equipped)</b>	<ol style="list-style-type: none"> <li>1. Motor not running.</li> <li>2. Loose wire connection.</li> <li>3. LED burnt out.</li> </ol>	<ol style="list-style-type: none"> <li>1. Start engine.</li> <li>2. Check wire connections at engine and both lights.</li> <li>3. Replace LED light module. (Individual LEDs are not replaceable)</li> </ol>
<b>Rotator hard to move</b>	<ol style="list-style-type: none"> <li>1. Debris in chute rotator mechanism.</li> <li>2. Cable are kinked or damaged.</li> </ol>	<ol style="list-style-type: none"> <li>1. Clean internal parts of chute rotator mechanism.</li> <li>2. Ensure cables are not kinked. Replace damaged cables.</li> </ol>

## WARRANTY

### Product Warranty

Please keep your original purchase receipt in a safe place as proof of purchase.

Warranty coverage for this product must be verified by the original purchase receipt.

The warranty period begins on the day that the product was purchased from an authorized retailer of Yard Force products. Warranty coverage only applies to the original purchaser and is not transferrable.

Warranty coverage is only provided on products purchased from authorized Yard Force retailers.

Warranty only applies to products purchased and OPERATED in the USA. Any product purchased or operated outside of the USA is not covered by any warranty.

### (1) Two-Year Limited Warranty

The Yard Force Outdoor Power Equipment has a Two-Year Limited Warranty from the date of purchase against manufacturer defects for residential use only. Commercial use voids the warranty. This warranty does not cover accidental damage, unreasonable use, normal wear and tear, neglect or non-compliance with the Operating, Safety and Maintenance Instructions. All service, outside of normal maintenance as described in this manual, must be done by an authorized service technician. Any unauthorized service or changes to the original configuration of this product will void the warranty. All parts and accessories used on and with this product must be manufactured and/or authorized by Merotec Inc.

### (2) Ninety-Day Warranty – Accessories

The accessories included with the machine including belt, auger, and other similar parts are warranted against manufacturer defects for residential use only for a period of 90 days from date of purchase.

Warranty does not cover loss of use or other consequential damages arising from any of the above, nor does it cover repairs made or attempted by unauthorized persons.

This warranty is void if the product is used for commercial, rental or industrial purposes.

Certain parts, attachments and accessories are subject to normal wear and tear and are excluded from the warranty.

### Service and Warranty Claims Process

Contact the Yard Force Support Center toll-free at **(866) 902-9690 Monday-Friday between 8:30 AM and 5:00 PM Eastern Time** for service and warranty support.

Yard Force Service Support agents can help you troubleshoot problems over the phone to get you back up and running as quickly as possible. In the situation where service or warranty inspection is needed, please follow these steps:

1. Call Yard Force at **(866) 902-9690 Monday-Friday between 8:30 AM and 5:00 PM Eastern Time**.
2. Send in proof-of-purchase and serial number (if applicable) to confirm warranty Coverage as directed by Yard Force.
3. If service or a warranty evaluation is requested, Yard Force will provide an RGA number that should be used in all communications with Yard Force and is required to be indicated on the product itself and on the outside of the box.
4. All shipments to Yard Force must have an RGA number. Any shipment received that does not have an RGA number clearly marked on the outside of the box will be refused.
5. All shipments must be sent pre-paid, Yard Force does not pay for any shipping costs for service or warranty evaluation. Yard Force is not responsible for any packages that are lost by carrier. We recommend that shipments are made by a carrier that provides tracking and delivery confirmation.

For more information or to ask questions, please call toll-free **(866) 902-9690 Monday-Friday between 8:30 AM and 5:00 PM Eastern Time**.

**SAVE THESE INSTRUCTIONS**

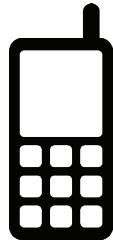

1-866-902-9690



support@merotecusa.com

## Need Help?

Please do not return the product to the place of purchase yet.  
We're here to help and take care of all your needs.

### Contact our Customer Care Center in Atlanta, GA for help with:

- Product assembly or use
- Missing or damaged parts
- Troubleshooting

You can also visit our website to download  
owner's manuals and get additional product information.  
Visit [www.YardForceUSA.com](http://www.YardForceUSA.com), or call our  
toll free hotline: 1-866-902-9690 M-F 8:30am – 5:00pm ET