

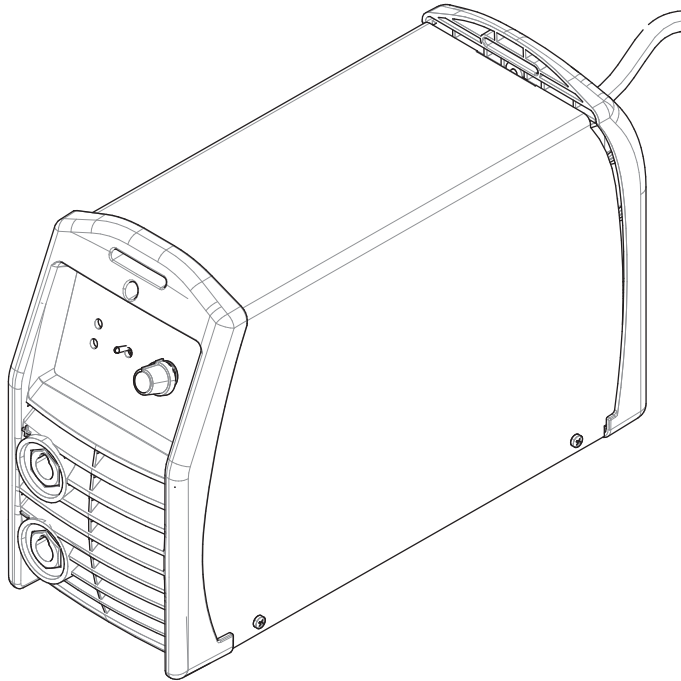

# Operator's Manual

# Inverter Arc™ 230



For use with Product Numbers:  
**12745**



**Register your machine:**  
[www.lincolnelectric.com/register](http://www.lincolnelectric.com/register)

**Authorized Service and Distributor Locator:**  
[www.lincolnelectric.com/locator](http://www.lincolnelectric.com/locator)

**Save for future reference**

Date Purchased

Code: (ex: 10859)

Serial: (ex: U1060512345)

**Need Help? Call 1.888.935.3877**  
to talk to a Service Representative

**Hours of Operation:**  
8:00 AM to 6:00 PM (ET) Mon. thru Fri.

**After hours?**  
Use "Ask the Experts" at [lincolnelectric.com](http://lincolnelectric.com)  
A Lincoln Service Representative will contact you  
no later than the following business day.

**For Service outside the USA:**  
Email: [globalservice@lincolnelectric.com](mailto:globalservice@lincolnelectric.com)

# THANK YOU FOR SELECTING A QUALITY PRODUCT BY LINCOLN ELECTRIC.

## PLEASE EXAMINE CARTON AND EQUIPMENT FOR DAMAGE IMMEDIATELY

When this equipment is shipped, title passes to the purchaser upon receipt by the carrier. Consequently, claims for material damaged in shipment must be made by the purchaser against the transportation company at the time the shipment is received.

## SAFETY DEPENDS ON YOU

Lincoln arc welding and cutting equipment is designed and built with safety in mind. However, your overall safety can be increased by proper installation ... and thoughtful operation on your part. **DO NOT INSTALL, OPERATE OR REPAIR THIS EQUIPMENT WITHOUT READING THIS MANUAL AND THE SAFETY PRECAUTIONS CONTAINED THROUGHOUT.** And, most importantly, think before you act and be careful.

### **WARNING**

This statement appears where the information must be followed exactly to avoid serious personal injury or loss of life.

### **CAUTION**

This statement appears where the information must be followed to avoid minor personal injury or damage to this equipment.



## KEEP YOUR HEAD OUT OF THE FUMES.

**DON'T** get too close to the arc. Use corrective lenses if necessary to stay a reasonable distance away from the arc.

**READ** and obey the Safety Data Sheet (SDS) and the warning label that appears on all containers of welding materials.

**USE ENOUGH VENTILATION** or exhaust at the arc, or both, to keep the fumes and gases from your breathing zone and the general area.

**IN A LARGE ROOM OR OUTDOORS**, natural ventilation may be adequate if you keep your head out of the fumes (See below).

**USE NATURAL DRAFTS** or fans to keep the fumes away from your face.

If you develop unusual symptoms, see your supervisor. Perhaps the welding atmosphere and ventilation system should be checked.

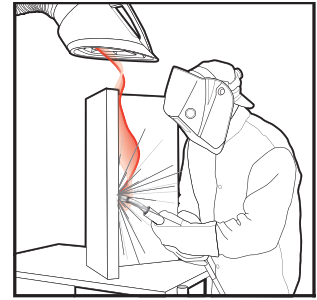

## WEAR CORRECT EYE, EAR & BODY PROTECTION

**PROTECT** your eyes and face with welding helmet properly fitted and with proper grade of filter plate (See ANSI Z49.1).

**PROTECT** your body from welding spatter and arc flash with protective clothing including woolen clothing, flame-proof apron and gloves, leather leggings, and high boots.

**PROTECT** others from splatter, flash, and glare with protective screens or barriers.

**IN SOME AREAS**, protection from noise may be appropriate.

**BE SURE** protective equipment is in good condition.

Also, wear safety glasses in work area **AT ALL TIMES.**



## SPECIAL SITUATIONS

**DO NOT WELD OR CUT** containers or materials which previously had been in contact with hazardous substances unless they are properly cleaned. This is extremely dangerous.

**DO NOT WELD OR CUT** painted or plated parts unless special precautions with ventilation have been taken. They can release highly toxic fumes or gases.

## Additional precautionary measures

**PROTECT** compressed gas cylinders from excessive heat, mechanical shocks, and arcs; fasten cylinders so they cannot fall.

**BE SURE** cylinders are never grounded or part of an electrical circuit.

**REMOVE** all potential fire hazards from welding area.

**ALWAYS HAVE FIRE FIGHTING EQUIPMENT READY FOR IMMEDIATE USE AND KNOW HOW TO USE IT.**



## SECTION A: WARNINGS



### CALIFORNIA PROPOSITION 65 WARNINGS



**WARNING:** Breathing diesel engine exhaust exposes you to chemicals known to the State of California to cause cancer and birth defects, or other reproductive harm.

- Always start and operate the engine in a well-ventilated area.
- If in an exposed area, vent the exhaust to the outside.
- Do not modify or tamper with the exhaust system.
- Do not idle the engine except as necessary.

For more information go to [www.P65warnings.ca.gov/diesel](http://www.P65warnings.ca.gov/diesel)

**WARNING:** This product, when used for welding or cutting, produces fumes or gases which contain chemicals known to the State of California to cause birth defects and, in some cases, cancer. (California Health & Safety Code § 25249.5 *et seq.*)



**WARNING:** Cancer and Reproductive Harm  
[www.P65warnings.ca.gov](http://www.P65warnings.ca.gov)

**ARC WELDING CAN BE HAZARDOUS. PROTECT YOURSELF AND OTHERS FROM POSSIBLE SERIOUS INJURY OR DEATH. KEEP CHILDREN AWAY. PACEMAKER WEARERS SHOULD CONSULT WITH THEIR DOCTOR BEFORE OPERATING.**

Read and understand the following safety highlights. For additional safety information, it is strongly recommended that you purchase a copy of "Safety in Welding & Cutting - ANSI Standard Z49.1" from the American Welding Society, P.O. Box 351040, Miami, Florida 33135 or CSA Standard W117.2-1974. A Free copy of "Arc Welding Safety" booklet E205 is available from the Lincoln Electric Company, 22801 St. Clair Avenue, Cleveland, Ohio 44117-1199.

**BE SURE THAT ALL INSTALLATION, OPERATION, MAINTENANCE AND REPAIR PROCEDURES ARE PERFORMED ONLY BY QUALIFIED INDIVIDUALS.**



### FOR ENGINE POWERED EQUIPMENT.

- 1.a. Turn the engine off before troubleshooting and maintenance work unless the maintenance work requires it to be running.
- 1.b. Operate engines in open, well-ventilated areas or vent the engine exhaust fumes outdoors.
- 1.c. Do not add the fuel near an open flame welding arc or when the engine is running. Stop the engine and allow it to cool before refueling to prevent spilled fuel from vaporizing on contact



with hot engine parts and igniting. Do not spill fuel when filling tank. If fuel is spilled, wipe it up and do not start engine until fumes have been eliminated.

- 1.d. Keep all equipment safety guards, covers and devices in position and in good repair. Keep hands, hair, clothing and tools away from V-belts, gears, fans and all other moving parts when starting, operating or repairing equipment.
- 1.e. In some cases it may be necessary to remove safety guards to perform required maintenance. Remove guards only when necessary and replace them when the maintenance requiring their removal is complete. Always use the greatest care when working near moving parts.
- 1.f. Do not put your hands near the engine fan. Do not attempt to override the governor or idler by pushing on the throttle control rods while the engine is running.
- 1.g. To prevent accidentally starting gasoline engines while turning the engine or welding generator during maintenance work, disconnect the spark plug wires, distributor cap or magneto wire as appropriate.
- 1.h. To avoid scalding, do not remove the radiator pressure cap when the engine is hot.



### ELECTRIC AND MAGNETIC FIELDS MAY BE DANGEROUS



- 2.a. Electric current flowing through any conductor causes localized Electric and Magnetic Fields (EMF). Welding current creates EMF fields around welding cables and welding machines
- 2.b. EMF fields may interfere with some pacemakers, and welders having a pacemaker should consult their physician before welding.
- 2.c. Exposure to EMF fields in welding may have other health effects which are now not known.
- 2.d. All welders should use the following procedures in order to minimize exposure to EMF fields from the welding circuit:
  - 2.d.1. Route the electrode and work cables together - Secure them with tape when possible.
  - 2.d.2. Never coil the electrode lead around your body.
  - 2.d.3. Do not place your body between the electrode and work cables. If the electrode cable is on your right side, the work cable should also be on your right side.
  - 2.d.4. Connect the work cable to the workpiece as close as possible to the area being welded.
  - 2.d.5. Do not work next to welding power source.



## ELECTRIC SHOCK CAN KILL.



- 3.a. The electrode and work (or ground) circuits are electrically “hot” when the welder is on. Do not touch these “hot” parts with your bare skin or wet clothing. Wear dry, hole-free gloves to insulate hands.
- 3.b. Insulate yourself from work and ground using dry insulation. Make certain the insulation is large enough to cover your full area of physical contact with work and ground.

**In addition to the normal safety precautions, if welding must be performed under electrically hazardous conditions (in damp locations or while wearing wet clothing; on metal structures such as floors, gratings or scaffolds; when in cramped positions such as sitting, kneeling or lying, if there is a high risk of unavoidable or accidental contact with the workpiece or ground) use the following equipment:**

- Semiautomatic DC Constant Voltage (Wire) Welder.
  - DC Manual (Stick) Welder.
  - AC Welder with Reduced Voltage Control.
- 3.c. In semiautomatic or automatic wire welding, the electrode, electrode reel, welding head, nozzle or semiautomatic welding gun are also electrically “hot”.
  - 3.d. Always be sure the work cable makes a good electrical connection with the metal being welded. The connection should be as close as possible to the area being welded.
  - 3.e. Ground the work or metal to be welded to a good electrical (earth) ground.
  - 3.f. Maintain the electrode holder, work clamp, welding cable and welding machine in good, safe operating condition. Replace damaged insulation.
  - 3.g. Never dip the electrode in water for cooling.
  - 3.h. Never simultaneously touch electrically “hot” parts of electrode holders connected to two welders because voltage between the two can be the total of the open circuit voltage of both welders.
  - 3.i. When working above floor level, use a safety belt to protect yourself from a fall should you get a shock.
  - 3.j. Also see Items 6.c. and 8.



## ARC RAYS CAN BURN.



- 4.a. Use a shield with the proper filter and cover plates to protect your eyes from sparks and the rays of the arc when welding or observing open arc welding. Headshield and filter lens should conform to ANSI Z87.1 standards.
- 4.b. Use suitable clothing made from durable flame-resistant material to protect your skin and that of your helpers from the arc rays.
- 4.c. Protect other nearby personnel with suitable, non-flammable screening and/or warn them not to watch the arc nor expose themselves to the arc rays or to hot spatter or metal.



## FUMES AND GASES CAN BE DANGEROUS.



- 5.a. Welding may produce fumes and gases hazardous to health. Avoid breathing these fumes and gases. When welding, keep your head out of the fume. Use enough ventilation and/or exhaust at the arc to keep fumes and gases away from the breathing zone. **When welding hardfacing (see instructions on container or SDS) or on lead or cadmium plated steel and other metals or coatings which produce highly toxic fumes, keep exposure as low as possible and within applicable OSHA PEL and ACGIH TLV limits using local exhaust or mechanical ventilation unless exposure assessments indicate otherwise. In confined spaces or in some circumstances, outdoors, a respirator may also be required. Additional precautions are also required when welding on galvanized steel.**
- 5.b. The operation of welding fume control equipment is affected by various factors including proper use and positioning of the equipment, maintenance of the equipment and the specific welding procedure and application involved. Worker exposure level should be checked upon installation and periodically thereafter to be certain it is within applicable OSHA PEL and ACGIH TLV limits.
- 5.c. Do not weld in locations near chlorinated hydrocarbon vapors coming from degreasing, cleaning or spraying operations. The heat and rays of the arc can react with solvent vapors to form phosgene, a highly toxic gas, and other irritating products.
- 5.d. Shielding gases used for arc welding can displace air and cause injury or death. Always use enough ventilation, especially in confined areas, to insure breathing air is safe.
- 5.e. Read and understand the manufacturer’s instructions for this equipment and the consumables to be used, including the Safety Data Sheet (SDS) and follow your employer’s safety practices. SDS forms are available from your welding distributor or from the manufacturer.
- 5.f. Also see item 1.b.



## WELDING AND CUTTING SPARKS CAN CAUSE FIRE OR EXPLOSION.

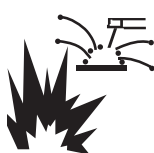

- 6.a. Remove fire hazards from the welding area. If this is not possible, cover them to prevent the welding sparks from starting a fire. Remember that welding sparks and hot materials from welding can easily go through small cracks and openings to adjacent areas. Avoid welding near hydraulic lines. Have a fire extinguisher readily available.
- 6.b. Where compressed gases are to be used at the job site, special precautions should be used to prevent hazardous situations. Refer to "Safety in Welding and Cutting" (ANSI Standard Z49.1) and the operating information for the equipment being used.
- 6.c. When not welding, make certain no part of the electrode circuit is touching the work or ground. Accidental contact can cause overheating and create a fire hazard.
- 6.d. Do not heat, cut or weld tanks, drums or containers until the proper steps have been taken to insure that such procedures will not cause flammable or toxic vapors from substances inside. They can cause an explosion even though they have been "cleaned". For information, purchase "Recommended Safe Practices for the Preparation for Welding and Cutting of Containers and Piping That Have Held Hazardous Substances", AWS F4.1 from the American Welding Society (see address above).
- 6.e. Vent hollow castings or containers before heating, cutting or welding. They may explode.
- 6.f. Sparks and spatter are thrown from the welding arc. Wear oil free protective garments such as leather gloves, heavy shirt, cuffless trousers, high shoes and a cap over your hair. Wear ear plugs when welding out of position or in confined places. Always wear safety glasses with side shields when in a welding area.
- 6.g. Connect the work cable to the work as close to the welding area as practical. Work cables connected to the building framework or other locations away from the welding area increase the possibility of the welding current passing through lifting chains, crane cables or other alternate circuits. This can create fire hazards or overheat lifting chains or cables until they fail.
- 6.h. Also see item 1.c.
- 6.i. Read and follow NFPA 51B "Standard for Fire Prevention During Welding, Cutting and Other Hot Work", available from NFPA, 1 Batterymarch Park, PO box 9101, Quincy, MA 022690-9101.
- 6.j. Do not use a welding power source for pipe thawing.



## CYLINDER MAY EXPLODE IF DAMAGED.

- 7.a. Use only compressed gas cylinders containing the correct shielding gas for the process used and properly operating regulators designed for the gas and pressure used. All hoses, fittings, etc. should be suitable for the application and maintained in good condition. 
- 7.b. Always keep cylinders in an upright position securely chained to an undercarriage or fixed support.
- 7.c. Cylinders should be located:
  - Away from areas where they may be struck or subjected to physical damage.
  - A safe distance from arc welding or cutting operations and any other source of heat, sparks, or flame.
- 7.d. Never allow the electrode, electrode holder or any other electrically "hot" parts to touch a cylinder.
- 7.e. Keep your head and face away from the cylinder valve outlet when opening the cylinder valve.
- 7.f. Valve protection caps should always be in place and hand tight except when the cylinder is in use or connected for use.
- 7.g. Read and follow the instructions on compressed gas cylinders, associated equipment, and CGA publication P-1, "Precautions for Safe Handling of Compressed Gases in Cylinders," available from the Compressed Gas Association, 14501 George Carter Way Chantilly, VA 20151.



## FOR ELECTRICALLY POWERED EQUIPMENT.



- 8.a. Turn off input power using the disconnect switch at the fuse box before working on the equipment.
- 8.b. Install equipment in accordance with the U.S. National Electrical Code, all local codes and the manufacturer's recommendations.
- 8.c. Ground the equipment in accordance with the U.S. National Electrical Code and the manufacturer's recommendations.

**Refer to**  
**<http://www.lincolnelectric.com/safety>**  
**for additional safety information.**

## **TABLE OF CONTENTS**

<b>INSTALLATION.....</b>	<b>SECTION A</b>
TECHNICAL SPECIFICATIONS .....	A-1
SELECT SUITABLE LOCATION.....	A-1
STACKING .....	A-1
TILTING .....	A-1
HIGH FREQUENCY PROTECTION.....	A-1
INPUT CONNECTIONS.....	A-2
OUTPUT CONNECTIONS.....	A-2
FACTORY INSTALLED .....	A-2
<b>OPERATION .....</b>	<b>SECTION B</b>
GENERAL DESCRIPTION.....	B-1
WELDING CAPABILITY.....	B-1
LIMITATIONS .....	B-1
CONTROLS AND OPERATIONAL FEATURES.....	B-2
ARC-WELDING CIRCUIT.....	B-3
ELECTRIC ARC.....	B-3
MAKING A WELD.....	B-4
<b>OPTIONAL KITS AND ACCESSORIES.....</b>	<b>SECTION C</b>
<b>MAINTENANCE.....</b>	<b>SECTION D</b>
ROUTINE MAINTENANCE.....	D-1
<b>TROUBLESHOOTING.....</b>	<b>SECTION E</b>
HOW TO USE TROUBLESHOOTING GUIDE.....	E-1
<b>WIRING DIAGRAM.....</b>	<b>SECTION F</b>
<b>PARTS LIST .....</b>	<b>PARTS.LINCOLNELECTRIC.COM</b>

CONTENT/DETAILS MAY BE CHANGED OR UPDATED WITHOUT NOTICE. FOR MOST CURRENT INSTRUCTION MANUALS, GO TO PARTS.LINCOLNELECTRIC.COM.

# INSTALLATION

## TECHNICAL SPECIFICATIONS - K2790-2 - Inverter Arc 230

INPUT - SINGLE PHASE ONLY	
Input Voltages 60 Hz.	Rated Input Current
230VAC ± 15%	25 AMPS @ RATED OUTPUT

RATED OUTPUT			
Duty Cycle	Output Amps	Output Volts	Input Circuit
30%	150A(TIG) 150A (STICK)	16.0 VDC 26.0 VDC	230 VAC

OUTPUT		
Output Current Range	Maximum Open Circuit Voltage	Type of Output
10-155 AMPS	77 VDC	DC

RECOMMENDED INPUT WIRE AND FUSE SIZES FOR MAXIMUM RATED OUTPUT		
INPUT VOLTAGE / FREQUENCY (HZ)	TYPE SJT OR HARD USAGE INPUT CORD	MAXIMUM TIME-DELAY CIRCUIT BREAKER OR FUSE SIZE (AMPS)
230/60	3 CONDUCTOR, 12 AWG	30

PHYSICAL DIMENSIONS	
Height	10.0 IN. (254.0 MM)
Width	5.5 IN. ( 140.0 MM)
Depth	14.2 IN. ( 360.7 MM)
Weight	18.0 LBS. (8.2 KGS.)

TEMPERATURE RANGES	
Operating Temperature	-10°C TO 40°C
Storage Temperature	-25°C TO 55°C

Thermal tests have been performed at ambient temperature. The duty cycle (duty factor) at 40°C has been determined by simulation.

## SAFETY PRECAUTIONS

### WARNING

#### ELECTRIC SHOCK can kill.

- Only qualified personnel should perform this installation.
- Disconnect input power by removing plug from receptacle before working inside Inverter Arc 230 Allow machine to sit for 5 minutes minimum to allow the power capacitors to discharge before working inside this equipment.
- Insulate yourself from the work and ground.
- Always wear dry insulating gloves.
- Always connect the Inverter Arc 230 to a power supply grounded according to the National Electrical Code and local codes.



## SELECT SUITABLE LOCATION

This machine can operate in harsh environments.

However, it is important that simple preventative measures are followed to assure long life and reliable operation:

- This machine must be located where there is free circulation of clean air without restrictions for air movement to and from the air vents. Do not cover the machine with paper, cloth or rags when switched on.
- Dirt and dust that can be drawn into the machine should be kept to a minimum.
- This machine has a protection rating of IP21S. Keep it dry and do not place it on wet ground or in puddles. Do not use in wet or damp locations. Store indoors.
- Locate the machine away from radio controlled machinery. Normal operation may adversely affect the operation of nearby radio controlled machinery, which may result in injury or equipment damage. Read the section on electromagnetic compatibility in this manual.
- Do not operate in areas with an ambient temperature greater than 40°C.

## STACKING

The Inverter Arc 230 cannot be stacked.

## TILTING

Place the machine directly on a secure, level surface. Do not place or operate this machine on a surface with an incline greater than 15° from horizontal. The machine may topple over if this procedure is not followed.

## HIGH FREQUENCY PROTECTION

Locate the Inverter Arc 230 away from radio controlled machinery. The normal operation of the Inverter Arc 230 may adversely affect the operation of RF controlled equipment, which may result in bodily injury or damage to the equipment.

**INPUT CONNECTIONS**

**Ground Connection**

The frame of the welder must be grounded. A ground terminal marked with the symbol is located on the under panel for this purpose. See your local and national electrical codes for proper grounding methods.



**WARNING**

A grounding conductor is supplied in the input cord, it is important that the supply receptacle ground is connected.



- The welding power source supply cable is provided with a green or yellow/green wire that must ALWAYS be earthed. This green or yellow/green wire must NEVER be used with other voltage conductors.
- Only install plugs that conform with safety regulations.

**Input Power Connection**

Check the input voltage, phase, and frequency supplied to this machine before turning it on. The allowable input voltage is indicated in the technical specification section of this manual and on the rating plate of the machine. Be sure that the machine is grounded.

Make sure the power available at the input connection is adequate for normal operation of the machine. The fuse rating and cable sizes are both indicated in the technical specification section of this manual.

Fuse the input circuit with time delay fuses marked “D” or delay type<sup>(1)</sup> circuit breakers. Using fuses or circuit breakers smaller than recommended may result in “nuisance” shut-offs from welder inrush currents even if not welding at high currents.

(1) Also called “inverse time” or “thermal/magnetic” circuit breakers. These circuit breakers have a delay in tripping action that decreases as the magnitude of the current increases.

The Inverter Arc 230 is recommended for use on an individual branch circuit.

**230V INPUT**

The Inverter Arc 230 is provided with a 230V cable, 6.0ft.(1.8m) in length, with a 50 Amp (NEMA 6-50P) plug molded onto the cord.

The rated output of the Inverter Arc 230 is available when connected to a 30A branch circuit. When connected to a branch circuit with lower ampacity, lower welding current and duty cycle must be used. Other loads on the circuit and fuse/circuit breaker characteristics will affect the available output.

**OUTPUT CONNECTIONS**

A quick disconnect system using Twist-Mate™ cable plugs is used for the welding cable connections.

**WARNING**

**ELECTRIC SHOCK can kill.**

- Keep the electrode holder and cable insulation in good condition.
- Do not touch electrically live parts or electrode with skin or wet clothing.
- Insulate yourself from work and ground.
- Turn the input line Switch on the AUTOPRO™ 90S “off” before connecting or disconnecting output cables or other equipment.



**Stick Welding (SMAW)**

First determine the proper electrode polarity for the electrode to be used. Consult the electrode data for this information. Then connect the output cables to the output terminals of the machine for the selected polarity. Shown here is the connection method for DC(+) welding. (See Figure A.1)

Connect the electrode cable to the (+) terminal and the work clamp to the (-) terminal. Insert the connector with the key lining up with the keyway and rotate approximately 1/4 turn clockwise. Do not over tighten.

For DC(-) welding, switch the cable connections at the machine so that the electrode cable is connected to (-) and the work clamp is connected to (+).

**FIGURE A.1**

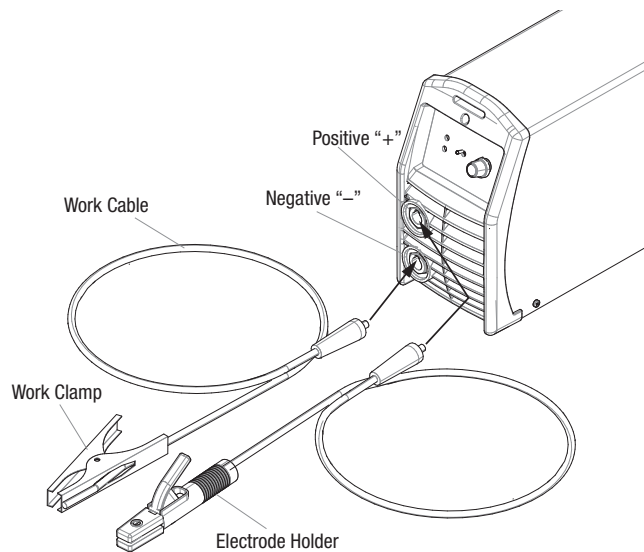

**TIG WELDING (GTAW)**

This machine does not have a built in Gas Solenoid so a one piece gas valve TIG Torch is required. A K960-1 Twist-mate TIG Torch adapter is also required. Refer to the accessories section for more information about TIG Torches and required Twist-mate adapter. Most TIG welding is done with DC(-) polarity shown here. If DC(+) polarity is necessary switch the cable connections at the machine. (See Figure A.2)

Connect the torch cable to the (-) terminal of the machine and the work clamp to the (+) terminal. Insert the connector with the key lining up with the keyway and rotate approximately 1/4 turn clockwise. Do not over tighten. Finally, connect the Twist-mate adapter gas hose to the gas regulator on the cylinder of gas to be used.

**FIGURE A.2**

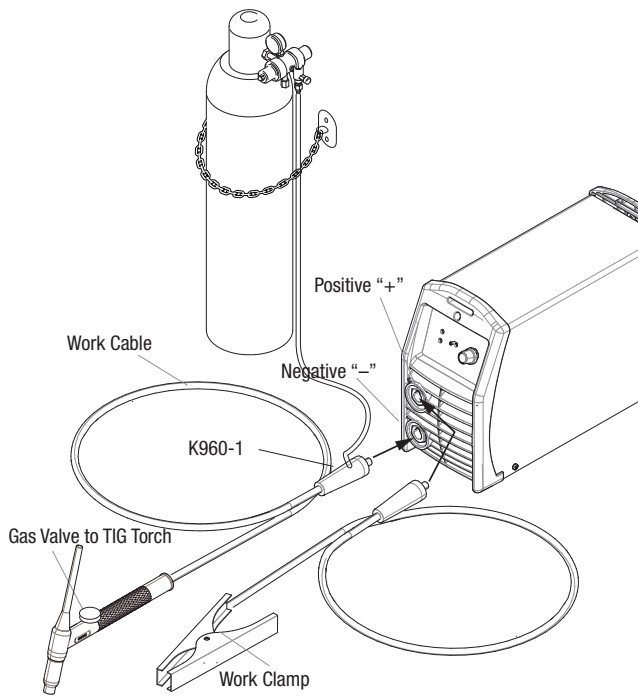

# OPERATION

Read and understand this entire section before operating your machine.

## Safety Precautions

Do not attempt to use this equipment until you have thoroughly read all operating and maintenance manuals supplied with your equipment and any related welding machine it will be used with. They include important safety precautions, operating and maintenance instructions and parts lists.

### **WARNING**

#### **ELECTRIC SHOCK can kill.**

- Do not touch electrically live parts such as output terminals or internal wiring.
- Insulate yourself from the work and ground.
- Always wear dry insulating gloves.



#### **WELDING SPARKS can cause fire or explosion.**

- Keep flammable material away.
- Do not weld upon containers which have held combustibles.

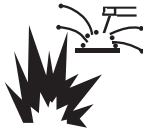

#### **ARC RAYS can burn.**

- Wear eye, ear and body protection.



#### **FUMES AND GASES can be dangerous.**

Although the removal of the particulate matter from welding smoke may reduce the ventilation requirement, concentrations of the clear exhausted fumes and gases may still be hazardous to health. Avoid breathing concentrations of these fumes and gases. Use adequate ventilation when welding. See ANSI Z49.1, "Safety in Welding and Cutting", published by the American Welding Society.



Only qualified personnel should operate this equipment. Observe all safety information throughout this manual.

## GENERAL DESCRIPTION

The Inverter Arc 230 is a 150 amp arc welding power source which utilizes single phase input power to produce constant current output. The welding response of this Inverter has been optimized for stick (SMAW) and TIG (GTAW) welding.

## WELDING CAPABILITY

The Inverter Arc 230 is rated at 150 amps at 30% duty cycle on a ten minute basis. It is capable of higher duty cycles at lower output currents. If the duty cycle is exceeded, a thermal protector will shut off the output until the machine cools.

The Inverter Arc 230 is recommended for the following Electrode Types and Diameters:

**TABLE A.2**

Types	ELECTRODE SIZES IN (MM)			
	5/64 (2.0)	3/32 (2.4)	1/8 (3.2)	5/32 (4.0)
FLEETWELD 37 (E6013)	•	•	•	
FLEETWELD 35 (E6011)		•	•	•
EXCALIBUR 7018 MR (E7018)		•	•	

## LIMITATIONS

The Inverter Arc 230 is not recommended for pipe thawing.

**CONTROLS AND OPERATIONAL FEATURES**

**FRONT CONTROL PANEL**

1. **Output Current Knob:** Potentiometer used to set the output current used during welding. Set the output according to the type and size of electrode.
2. **Welding Mode Switch:** Controls the welding mode of the machine:  
Select Stick welding or Lift TIG welding.
  - Stick (SMAW):
  - Lift TIG (GTAW): When the mode switch is in the Lift TIG position, the stick welding functions are disabled and the machine is ready for Lift TIG welding. Lift TIG is a method of starting a TIG weld by first pressing the TIG torch electrode on the work piece in order to create a low current short circuit. Then, the electrode is lifted from the work piece to start the TIG arc.
3. **Thermal LED:** This indicator will turn on when the machine is overheated and the output has been disabled. This normally occurs when the duty cycle of the machine has been exceeded. Leave the machine on to allow the internal components to cool. When the indicator turns off, normal operation is again possible.
4. **Power LED:** After the power switch is turned on the LED will illuminate.
5. **Positive Quick Disconnect:** Positive output connector for the welding circuit.
6. **Negative Quick Disconnect:** Negative output connector for the welding circuit.

**FIGURE B.1**

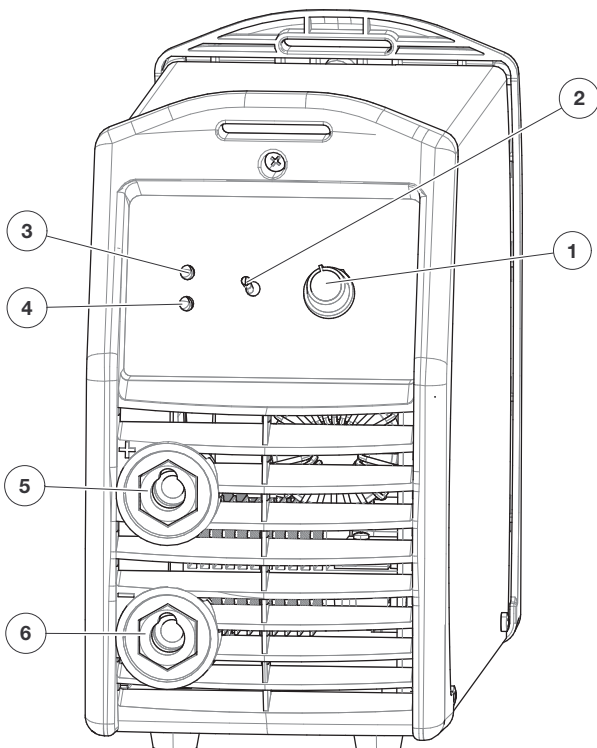

**REAR CONTROL PANEL**

(See Figure B.2)

7. **Power Switch:** It turns ON / OFF the input power to the machine.
8. **Input cable:** This machine is provided with a plugged input cord. Connect it to the mains.

**FIGURE B.2**

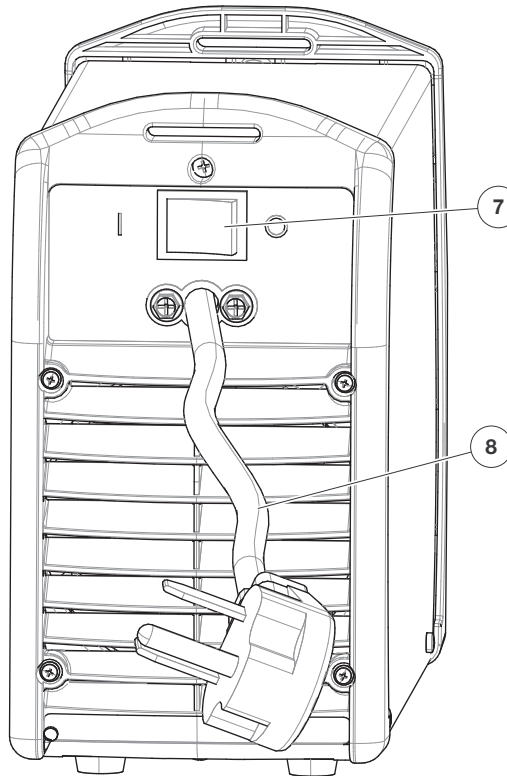

**ARC-WELDING CIRCUIT**

(See Figure B.3)

**FIGURE B.3**

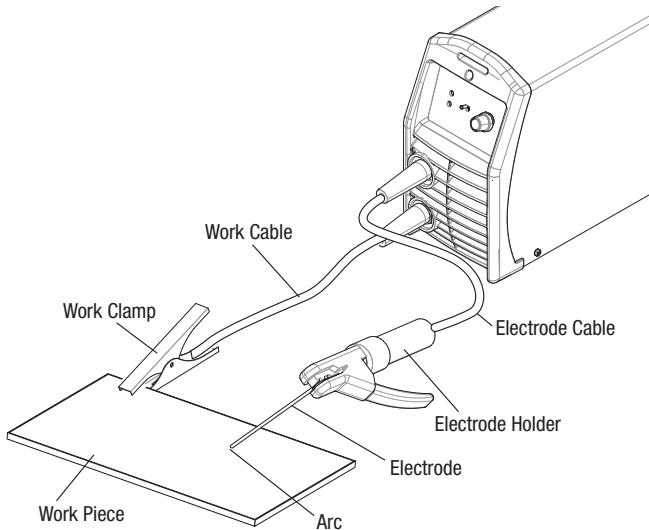

Current flows through the electrode cable and electrode holder to the electrode and across the arc. On the work side of the arc, the current flows through the base metal to the work cable and back to the welding machine. The circuit must be complete for the current to flow.

To weld, the work clamp must be tightly connected to clean base metal. Remove paint, rust, etc. as necessary to get a good connection. Connect the work clamp as close as possible to the area you wish to weld. Avoid allowing the welding circuit to pass through hinges, bearings, electronic components or similar devices that can be damaged.

An electric arc is made between the work and the end of a small metal rod, the electrode, which is clamped in a holder and the holder is held by the person doing the welding. A gap is made in the welding circuit (see Figure B.3) by holding the tip of the electrode 1/16-1/8" away from the work or base metal being welded. The electric arc is established in this gap and is held and moved along the joint to be welded, melting the metal as it is moved.

**ELECTRIC ARC**

(See Figure B.4)

Action that takes place in the electric arc.

**FIGURE B.4**

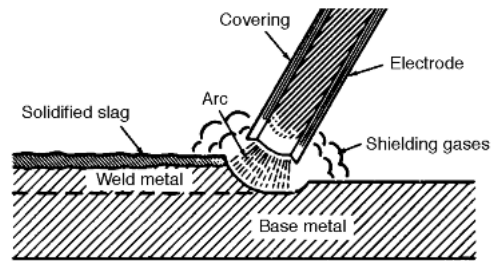

This figure closely resembles what is actually seen during welding. The "arc stream" is seen in the middle of the figure. This is the electric arc created by the electric current flowing through the space between the end of the electrode and the work.

The temperature of this arc is about 6000°F (3315°C), which is more than enough to melt metal. The arc is very bright, as well as hot, and cannot be looked at with the naked eye without risking painful injury. A very dark lens, specifically designed for arc welding, must be used with a hand or face shield whenever viewing the arc. The arc melts the base metal and actually digs into it, much as water through a nozzle on a garden hose digs into the earth. The molten metal forms a pool or crater and tends to flow away from the arc. As it moves away from the arc, it cools and solidifies. A slag forms on top of the weld to protect it during cooling.

The function of the covered electrode is much more than simply to carry current to the arc. The electrode is composed of a core rod of metal with an extruded chemical covering. The core rod melts in the arc and tiny droplets of molten metal shoot across the arc into the molten pool. The electrode provides additional filler metal for the joint to fill the groove or gap between the two pieces of the base metal. The covering also melts or burns in the arc. It has several functions. It makes the arc steadier, provides a shield of smoke-like gas around the arc to keep oxygen and nitrogen in the air away from the molten metal, and provides a flux for the molten pool. The flux picks up impurities and forms the protective slag.

**MAKING A WELD**

Insert the bare part of the electrode into the electrode holder jaws and connect the work clamp to the welding piece. Make sure to have good electrical contact.

1. Turn the welder on.
2. Lower your welding helmet to protect your face and eyes.
3. Strike the electrode at the work point on the workpiece as if striking a match. Do not hit the electrode on the workpiece, which will damage the stick electrode and make striking an arc difficult. Scratch the electrode slowly over the metal and you will see sparks. While scratching, lift the electrode 1/8" (3.2mm) and the arc will establish.

**NOTE:** If you stop moving the electrode while scratching, the electrode will stick.

**NOTE:** Most beginners try to strike the arc by a fast jabbing motion down on the plate. Result: They either stick or their motion is so fast that they break the arc immediately.

4. Immediately after striking the arc try to maintain a distance from the workpiece that is equivalent to the diameter of the electrode used. Maintain this distance as constantly as possible during the weld. Whenever possible, weld from left to right (if right-handed). Hold the electrode at a slight angle as shown. (See Figure B.5)

**FIGURE B.5**

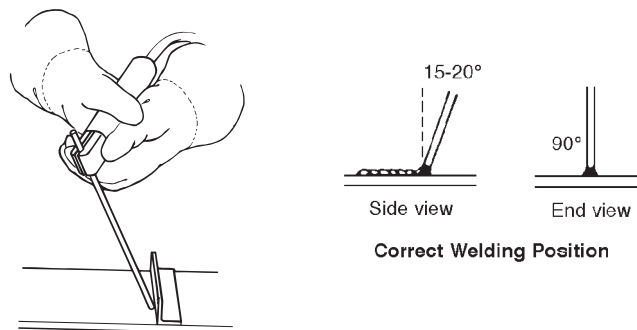

5. As the electrode burns off the electrode must be fed to the work to maintain correct arc length. The easiest way to tell whether the arc has the correct length is by listening to its sound. A nice, short arc has a distinctive, "crackling" sound, very much like eggs frying in a pan. The incorrect, long arc has a hollow, blowing or hissing sound.

6. The important thing to watch while welding is the puddle of molten metal right behind the arc. Do NOT watch the arc itself. It is the appearance of the puddle and the ridge where the molten puddle solidifies that indicate correct welding speed. The ridge should be approximately 3/8" (9.5mm) behind the electrode. (See Figure B.6)

**FIGURE B.6**

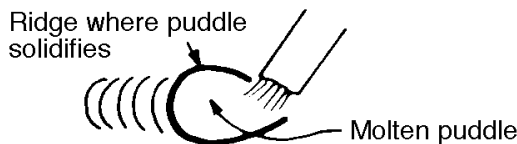

Most beginners tend to weld too fast, resulting in a thin, uneven, "wormy" looking bead. They are not watching the molten metal.

**IMPORTANT:** For general welding it is not necessary to weave the arc; neither forwards and backwards nor sideways. Weld along at a steady pace. You will find it easier. **NOTE:** When welding on thin plate, you will find that you will have to increase the welding speed, whereas when welding on heavy plate, it is necessary to go more slowly in order to get good penetration.

7. Once the electrode is burned down move the electrode quickly from the weld to extinguish the arc.
8. Turn the machine off and remove the stub by opening the jaws of the electrode holder and insert a new electrode.

**Note:** The welded work piece and electrode stub are hot after welding. Allow them to cool down before touching or use pliers to move. Always make sure the welder is turned off before setting down the Electrode Holder.

**TIG WELDING (TUNGSTEN INERT GAS WELDING)**

This machine is capable of direct current (DC) TIG welding which is suitable for hard metals such as steel, stainless steel, copper & brass. The TIG process is good for welding thin materials requiring very good cosmetic appearance with low heat input and low spatter. TIG welding uses a tungsten electrode which delivers electrical current to the work piece by way of an electric arc. Unlike stick welding in which the electrode is consumed in the arc, the tungsten electrode is not consumed. Instead filler metal is added to the weld by manually dipping a filler rod into the weld puddle. TIG welding requires a higher skill level than stick welding and practice is required to master the technique. For best results a TIG welding class is suggested or obtaining a book on how to TIG weld.

TIG welding also requires 100% Argon shielding gas to shield the arc, preventing porosity in the weld. This is different than stick welding which has a coating on the electrode to produce its own shielding. In addition, a gas regulator, a manual gas valve TIG torch, torch parts kit, torch adaptor and filler metal are required. Refer to the accessories section of this manual for an appropriate optional TIG torch, parts kit and torch adaptor. A gas regulator, filler metal and a bottle of shielding gas are readily available from a welding gas distributor.

Figure B.7 shows the basic TIG welding set-up:

**FIGURE B.7**

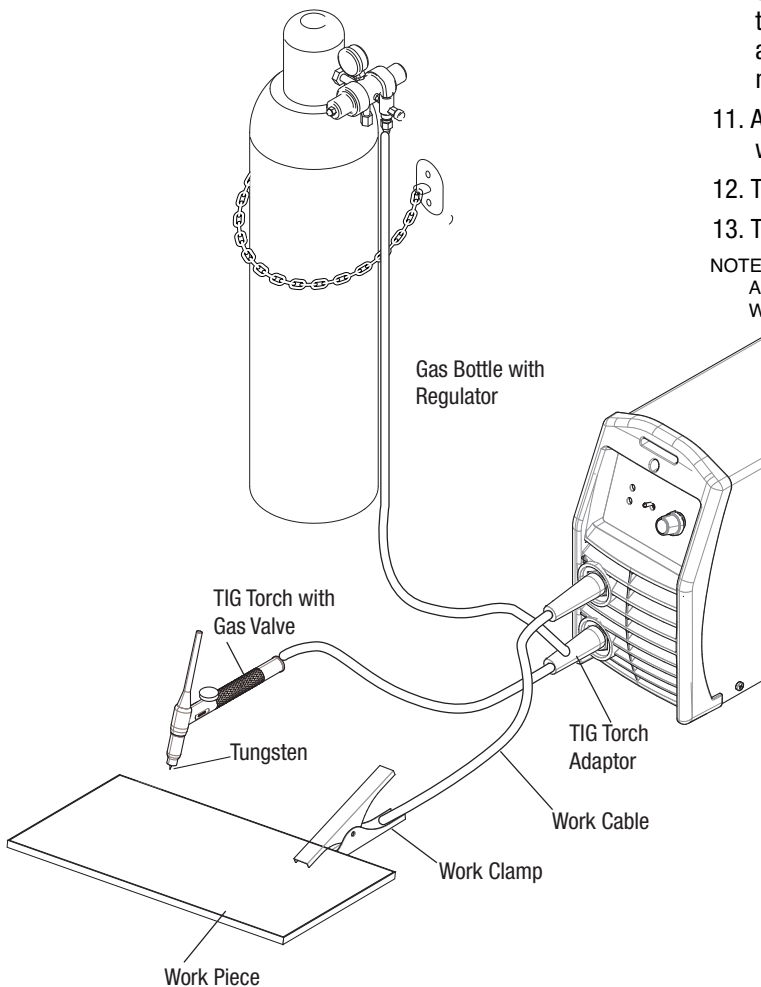

**MAKING A TIG WELD:**

1. Connect the work cable to the positive “+” output terminal.
2. Connect the TIG torch to the negative “-“ output terminal.
3. Connect the gas line from the TIG torch adapter to the gas regulator connected to the gas bottle.
4. Open the gas valve on the gas bottle and adjust the gas regulator to approximately 20-30 cfm.
5. Set the amperage based on material thickness:
 

Steel Thickness	Amperage Setting
(1/16”) 1.6mm	60-90 Amps
(1/8”) 3.2mm	75-120 Amps
(3/16) 4.8mm	125-150 Amps
6. Turn machine on.
7. Turn the gas valve on the torch to start shielding gas flowing.
8. Touch the tungsten to the work piece and pause for a second.
9. Slowly lift the tungsten off the work piece to establish the arc. (Note: Rocking the torch back onto the ceramic shielding cup is an easy way to do this steadily.)
10. With the torch pointed in the direction of travel angled about 75 degrees to the work piece slowly move the torch in the direction of travel. Maintain about a 1/4” distance from the tungsten to the work piece while moving. Apply filler metal to the weld puddle by dipping the filler rod into the weld puddle allowing it to melt off and being careful not to touch the filler metal to the tungsten electrode.
11. At the end of the weld lift the TIG torch quickly away from the work piece to break the arc.
12. Turn off torch gas valve.
13. Turn machine off.

NOTE: For more detailed information about TIG welding order “Gas Tungsten Arc Welding Guide Book (JFLF-834)” from the James F. Lincoln Arc Welding Foundation.

# OPTIONAL KITS AND ACCESSORIES

---

---

## FACTORY INSTALLED

Electrical Holder and Cable Assembly  
Work Cable and Clamp  
Strap Packet  
Instruction Manual

---

## FIELD INSTALLED

**PTA-17V TIG Torch** - 150 Amp air-cooled compact and durable Tig Torch with integral gas valve for gas control at the torch. The following 1-piece cable torches can be used with a K960-1 adapter:

- K1782-6 (12.50 Ft.) 1-Piece Cable
- K1782-8 (25.0 Ft.) 1-Piece Cable

**PTA-9FV TIG Torch** - 125 Amp Gas Valve flexible head torch:

- K1781-7 (25.0 Ft.) 1-Piece Cable

**PTA-17FV TIG Torch** - 150 Amp Gas Valve flexible head torch:

- K1782-11 (25.0 Ft.) 1-Piece Cable
- K1782-13 (12.5 Ft.) 1-Piece Ultra Flex Cable

**K960-1-TIG Torch Adapter** - for connection of PTA-17V torches (1-piece cable) to power sources without gas passing through the Twist Mate connection.

---

## CABLE PLUGS

**K852-25 - Cable Plug Kit** attaches to welding cable to provide quick disconnect from machine.

**TIG Torch Parts Kits** - Parts kits are available for the PTA-9FV and PTA-17 TIG torch. These kits include back cap, collets, collet bodies, nozzles and tungstens.

Order KP508 for PTA-17 torches

Order KP507 for PTA-9 torches

See publication E12.150 for parts kits breakdown.

**Cut Length Consumables** - TIG welding filler metals are available for welding stainless steel, mild steel, aluminum and copper alloys. See Lincoln Electric publication C9.10.

# MAINTENANCE

## ⚠ WARNING

### ELECTRIC SHOCK can kill.

- Turn the input power OFF at the welding power source before installation or changing drive rolls and/or guides.
- Do not touch electrically live parts.
- When inching with the gun trigger, electrode and drive mechanism are "hot" to work and ground and could remain energized several seconds after the gun trigger is released.
- Do not operate with covers, panels or guards removed or open.
- Only qualified personnel should perform maintenance work.



### ROUTINE MAINTENANCE

The frequency of the maintenance operations may vary in accordance with the working environment. Any noticeable damage should be reported immediately.

- Check cables and connections integrity. Replace, if necessary.
- Clean the power source inside by means of low - pressure compressed air.
- Keep the machine clean. Use a soft dry cloth to clean the external case, especially the airflow inlet / outlet louvers.

## ⚠ WARNING

Do not open this machine and do not introduce anything into its openings. Power supply must be disconnected from the machine before each maintenance and service. After each repair, perform proper tests to ensure safety.

## ⚠ WARNING

Power supply must be disconnected from the machine before each maintenance and service. Always use gloves in compliance with the safety standards.

# TROUBLESHOOTING

## HOW TO USE TROUBLESHOOTING GUIDE

## ⚠ WARNING

Service and Repair should only be performed by Lincoln Electric Factory Trained Personnel. Unauthorized repairs performed on this equipment may result in danger to the technician and machine operator and will invalidate your factory warranty. For your safety and to avoid Electrical Shock, please observe all safety notes and precautions detailed throughout this manual.

This Troubleshooting Guide is provided to help you locate and repair possible machine malfunctions. Simply follow the three-step procedure listed below.

### Step 1. LOCATE PROBLEM (SYMPTOM).

Look under the column labeled "PROBLEM (SYMPTOMS)." This column describes possible symptoms that the machine may exhibit. Find the listing that best describes the symptom that the machine is exhibiting.

### Step 2. POSSIBLE CAUSE.

The second column labeled "POSSIBLE CAUSE" lists the obvious external possibilities that may contribute to the machine symptom.

### Step 3. RECOMMENDED COURSE OF ACTION

This column provides a course of action for the Possible Cause, generally it states to contact you local Lincoln Authorized Field Service Facility.

If you do not understand or are unable to perform the Recommended Course of Action safely, contact your local Lincoln Authorized Field Service Facility.

## ⚠ WARNING

### ELECTRIC SHOCK can kill.

- Turn off machine at the disconnect switch on the rear of the machine and remove main power supply connections before doing any troubleshooting.



Observe all Safety Guidelines detailed throughout this manual

PROBLEM (SYMPTOMS)	POSSIBLE AREAS OF MISADJUSTMENT(S)	RECOMMENDED COURSE OF ACTION
<b>WELDING PROBLEMS</b>		
Excessive spatter	1. Improper welding polarity.	1. Make sure the electrode holder is plugged into the positive “+” output terminal.
	2. Long Arc Length.	2. Move the electrode closer into the weld joint.
	3. High Current.	3. Turn the output knob down.
Craters	1. Fast movement of the electrode away from the work piece.	1. Maintain a steady consistent arc length
Inclusions	1. Poor cleanliness.	1. Clean work piece with wire brush prior to welding.
	2. Poor distribution of the welding passes.	2. Consult a welding guide for proper weld bead placement.
Insufficient penetration	1. High travel speed.	1. Travel at a slower speed.
	2. Welding current is too low.	2. Adjust welding output higher.
Electrode Sticking	1. Arc length is too short.	1. Move the electrode further away from the weld joint.
	2. Welding current is too low.	2. Turn the output knob up.
Porosity	1. Humidity in the electrode.	1. Store welding electrodes in a warm dry place.
	2. Long arc length.	2. Move the electrode closer into the weld joint.
Cracks	1. Weld current is set too high.	1. Turn the output knob down.
	2. Dirty materials.	2. Clean work piece with wire brush prior to welding.
	3. Hydrogen in the weld due to moisture.	3. Store welding electrodes in a warm dry place.
<b>ELECTRICAL FAILURES</b>		
Machine fails to come on (Power LED off)	1. No Input Voltage.	If all recommended possible areas of misadjustment have been checked and the problem persists, Contact your local Authorized Field Service Facility.
	2. Faulty supply plug or cable.	
	3. Supply fuse blown or breaker tripped.	
Thermal overload (Thermal LED on)	1. Unit has been operated beyond its capacity rating.	
	2. Airflow through machine is restricted or fan has failed.	
The fan works, but the output current is unstable and can not be controlled by the potentiometer while welding is carried out.	1. Check the output current potentiometer, and replace it if necessary.	
	2. Verify output cables are attached to the welder and tightly connected	



If for any reason you do not understand the test procedures or are unable to perform the tests/repairs safely, contact your Lincoln Authorized Service Facility for technical troubleshooting assistance before you proceed.

**WWW.LINCOLNELECTRIC.COM/LOCATOR**

INVERTER ARC 230 WIRING DIAGRAM

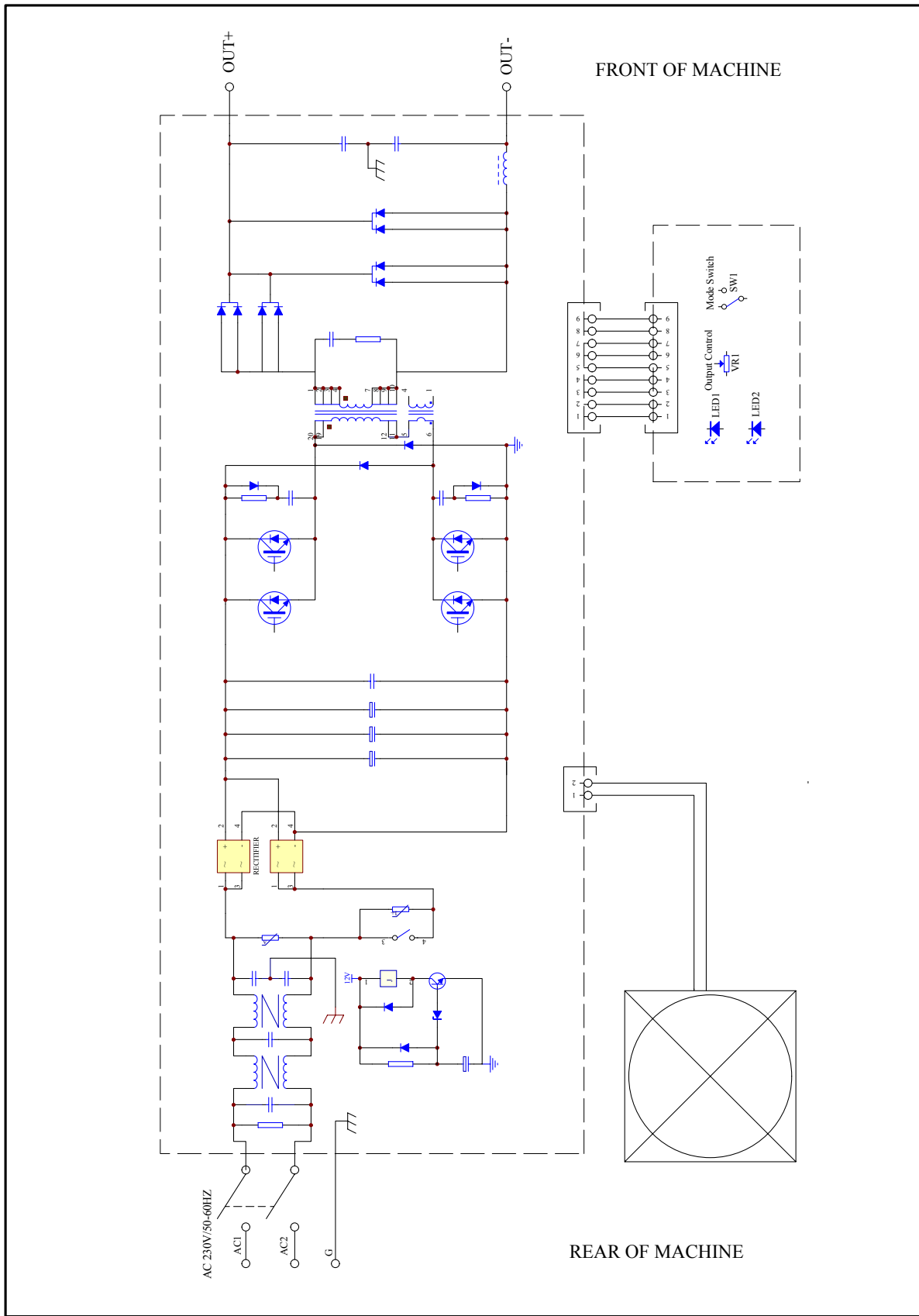

NOTE: This diagram is for reference only. It may not be accurate for all machines covered by this manual. The specific diagram for a particular code is pasted inside the machine on one of the enclosure panels. If the diagram is illegible, write to the Service Department for a replacement. Give the equipment code number.







			
<b>WARNING</b>	<ul style="list-style-type: none"> <li>● Do not touch electrically live parts or electrode with skin or wet clothing.</li> <li>● Insulate yourself from work and ground.</li> </ul>	<ul style="list-style-type: none"> <li>● Keep flammable materials away.</li> </ul>	<ul style="list-style-type: none"> <li>● Wear eye, ear and body protection.</li> </ul>
Spanish <b>AVISO DE PRECAUCION</b>	<ul style="list-style-type: none"> <li>● No toque las partes o los electrodos bajo carga con la piel o ropa mojada.</li> <li>● Aíslese del trabajo y de la tierra.</li> </ul>	<ul style="list-style-type: none"> <li>● Mantenga el material combustible fuera del área de trabajo.</li> </ul>	<ul style="list-style-type: none"> <li>● Protéjase los ojos, los oídos y el cuerpo.</li> </ul>
French <b>ATTENTION</b>	<ul style="list-style-type: none"> <li>● Ne laissez ni la peau ni des vêtements mouillés entrer en contact avec des pièces sous tension.</li> <li>● Isolez-vous du travail et de la terre.</li> </ul>	<ul style="list-style-type: none"> <li>● Gardez à l'écart de tout matériel inflammable.</li> </ul>	<ul style="list-style-type: none"> <li>● Protégez vos yeux, vos oreilles et votre corps.</li> </ul>
German <b>WARNUNG</b>	<ul style="list-style-type: none"> <li>● Berühren Sie keine stromführenden Teile oder Elektroden mit Ihrem Körper oder feuchter Kleidung!</li> <li>● Isolieren Sie sich von den Elektroden und dem Erdboden!</li> </ul>	<ul style="list-style-type: none"> <li>● Entfernen Sie brennbares Material!</li> </ul>	<ul style="list-style-type: none"> <li>● Tragen Sie Augen-, Ohren- und Körperschutz!</li> </ul>
Portuguese <b>ATENÇÃO</b>	<ul style="list-style-type: none"> <li>● Não toque partes elétricas e electrodos com a pele ou roupa molhada.</li> <li>● Isole-se da peça e terra.</li> </ul>	<ul style="list-style-type: none"> <li>● Mantenha inflamáveis bem guardados.</li> </ul>	<ul style="list-style-type: none"> <li>● Use proteção para a vista, ouvido e corpo.</li> </ul>
Japanese <b>注意事項</b>	<ul style="list-style-type: none"> <li>● 通電中の電気部品、又は溶材にヒフやぬれた布で触れないこと。</li> <li>● 施工物やアースから身体が絶縁されている様にして下さい。</li> </ul>	<ul style="list-style-type: none"> <li>● 燃えやすいものの側での溶接作業は絶対にしてはなりません。</li> </ul>	<ul style="list-style-type: none"> <li>● 目、耳及び身体に保護具をして下さい。</li> </ul>
Chinese <b>警告</b>	<ul style="list-style-type: none"> <li>● 皮肤或湿衣物切勿接触带电部件及焊条。</li> <li>● 使你自已与地面和工作件绝缘。</li> </ul>	<ul style="list-style-type: none"> <li>● 把一切易燃物品移离工作场所。</li> </ul>	<ul style="list-style-type: none"> <li>● 佩戴眼、耳及身体劳动保护用具。</li> </ul>
Korean <b>위험</b>	<ul style="list-style-type: none"> <li>● 전도체나 용접봉을 젖은 형갑 또는 피부로 절대 접촉치 마십시오.</li> <li>● 모재와 접지를 접촉치 마십시오.</li> </ul>	<ul style="list-style-type: none"> <li>● 인화성 물질을 접근시키지 마십시오.</li> </ul>	<ul style="list-style-type: none"> <li>● 눈, 귀와 몸에 보호장구를 착용하십시오.</li> </ul>
Arabic <b>تحذير</b>	<ul style="list-style-type: none"> <li>● لا تلمس الاجزاء التي يسري فيها التيار الكهربائي أو الألكترود بجسدك أو بالملابس المبللة بالماء.</li> <li>● ضع عازلا على جسمك خلال العمل.</li> </ul>	<ul style="list-style-type: none"> <li>● ضع المواد القابلة للاشتعال في مكان بعيد.</li> </ul>	<ul style="list-style-type: none"> <li>● ضع أدوات وملابس واقية على عينيك وأذنيك وجسمك.</li> </ul>

**READ AND UNDERSTAND THE MANUFACTURER'S INSTRUCTION FOR THIS EQUIPMENT AND THE CONSUMABLES TO BE USED AND FOLLOW YOUR EMPLOYER'S SAFETY PRACTICES.**

**SE RECOMIENDA LEER Y ENTENDER LAS INSTRUCCIONES DEL FABRICANTE PARA EL USO DE ESTE EQUIPO Y LOS CONSUMIBLES QUE VA A UTILIZAR, SIGA LAS MEDIDAS DE SEGURIDAD DE SU SUPERVISOR.**

**LISEZ ET COMPRENEZ LES INSTRUCTIONS DU FABRICANT EN CE QUI REGARDE CET EQUIPMENT ET LES PRODUITS A ETRE EMPLOYES ET SUIVEZ LES PROCEDURES DE SECURITE DE VOTRE EMPLOYEUR.**

**LESEN SIE UND BEFOLGEN SIE DIE BETRIEBSANLEITUNG DER ANLAGE UND DEN ELEKTRODENEINSATZ DES HERSTELLERS. DIE UNFALLVERHÜTUNGSVORSCHRIFTEN DES ARBEITGEBERS SIND EBENFALLS ZU BEACHTEN.**

			
<ul style="list-style-type: none"> <li>● Keep your head out of fumes.</li> <li>● Use ventilation or exhaust to remove fumes from breathing zone.</li> </ul>	<ul style="list-style-type: none"> <li>● Turn power off before servicing.</li> </ul>	<ul style="list-style-type: none"> <li>● Do not operate with panel open or guards off.</li> </ul>	<b>WARNING</b>
<ul style="list-style-type: none"> <li>● Los humos fuera de la zona de respiración.</li> <li>● Mantenga la cabeza fuera de los humos. Utilice ventilación o aspiración para gases.</li> </ul>	<ul style="list-style-type: none"> <li>● Desconectar el cable de alimentación de poder de la máquina antes de iniciar cualquier servicio.</li> </ul>	<ul style="list-style-type: none"> <li>● No operar con panel abierto o guardas quitadas.</li> </ul>	Spanish <b>AVISO DE PRECAUCION</b>
<ul style="list-style-type: none"> <li>● Gardez la tête à l'écart des fumées.</li> <li>● Utilisez un ventilateur ou un aspirateur pour ôter les fumées des zones de travail.</li> </ul>	<ul style="list-style-type: none"> <li>● Débranchez le courant avant l'entretien.</li> </ul>	<ul style="list-style-type: none"> <li>● N'opérez pas avec les panneaux ouverts ou avec les dispositifs de protection enlevés.</li> </ul>	French <b>ATTENTION</b>
<ul style="list-style-type: none"> <li>● Vermeiden Sie das Einatmen von Schweißrauch!</li> <li>● Sorgen Sie für gute Be- und Entlüftung des Arbeitsplatzes!</li> </ul>	<ul style="list-style-type: none"> <li>● Strom vor Wartungsarbeiten abschalten! (Netzstrom völlig öffnen; Maschine anhalten!)</li> </ul>	<ul style="list-style-type: none"> <li>● Anlage nie ohne Schutzgehäuse oder Innenschutzverkleidung in Betrieb setzen!</li> </ul>	German <b>WARNUNG</b>
<ul style="list-style-type: none"> <li>● Mantenha seu rosto da fumaça.</li> <li>● Use ventilação e exaustão para remover fumo da zona respiratória.</li> </ul>	<ul style="list-style-type: none"> <li>● Não opere com as tampas removidas.</li> <li>● Desligue a corrente antes de fazer serviço.</li> <li>● Não toque as partes elétricas nuas.</li> </ul>	<ul style="list-style-type: none"> <li>● Mantenha-se afastado das partes moventes.</li> <li>● Não opere com os painéis abertos ou guardas removidas.</li> </ul>	Portuguese <b>ATENÇÃO</b>
<ul style="list-style-type: none"> <li>● ヒュームから頭を離すようにして下さい。</li> <li>● 換気や排煙に十分留意して下さい。</li> </ul>	<ul style="list-style-type: none"> <li>● メンテナンス・サービスに取りかかる際には、まず電源スイッチを必ず切して下さい。</li> </ul>	<ul style="list-style-type: none"> <li>● パネルやカバーを取り外したまま機械操作をしないで下さい。</li> </ul>	Japanese <b>注意事項</b>
<ul style="list-style-type: none"> <li>● 頭部遠離煙霧。</li> <li>● 在呼吸區使用通風或排風器除煙。</li> </ul>	<ul style="list-style-type: none"> <li>● 維修前切斷電源。</li> </ul>	<ul style="list-style-type: none"> <li>● 儀表板打開或沒有安全罩時不準作業。</li> </ul>	Chinese <b>警告</b>
<ul style="list-style-type: none"> <li>● 얼굴로부터 용접가스를 멀리하십시오.</li> <li>● 호흡지역으로부터 용접가스를 제거하기 위해 가스제거기나 통풍기를 사용하십시오.</li> </ul>	<ul style="list-style-type: none"> <li>● 보수전에 전원을 차단하십시오.</li> </ul>	<ul style="list-style-type: none"> <li>● 판넬이 열린 상태로 작동치 마십시오.</li> </ul>	Korean <b>위험</b>
<ul style="list-style-type: none"> <li>● ابعد رأسك بعيداً عن الدخان.</li> <li>● استعمل التهوية أو جهاز ضغط الدخان للخارج لكي تبعد الدخان عن المنطقة التي تتنفس فيها.</li> </ul>	<ul style="list-style-type: none"> <li>● اقطع التيار الكهربائي قبل القيام بأية صيانة.</li> </ul>	<ul style="list-style-type: none"> <li>● لا تشغيل هذا الجهاز اذا كانت الاغطية الحديدية الواقية ليست عليه.</li> </ul>	Arabic <b>تحذير</b>

**LEIA E COMPREENDA AS INSTRUÇÕES DO FABRICANTE PARA ESTE EQUIPAMENTO E AS PARTES DE USO, E SIGA AS PRÁTICAS DE SEGURANÇA DO EMPREGADOR.**

使う機械や溶材のメーカーの指示書をよく読み、まず理解して下さい。そして貴社の安全規定に従って下さい。

請詳細閱讀並理解製造廠提供的說明以及應該使用的銀焊材料，並請遵守貴方的有關勞動保護規定。

이 제품에 동봉된 작업지침서를 숙지하시고 귀사의 작업자 안전수칙을 준수하시기 바랍니다.

اقرأ بتمعن وافهم تعليمات المصنع المنتج لهذه المعدات والمواد قبل استعمالها واتبع تعليمات الوقاية لصاحب العمل.

## **CUSTOMER ASSISTANCE POLICY**

The business of The Lincoln Electric Company is manufacturing and selling high quality welding equipment, consumables, and cutting equipment. Our challenge is to meet the needs of our customers and to exceed their expectations. On occasion, purchasers may ask Lincoln Electric for advice or information about their use of our products. We respond to our customers based on the best information in our possession at that time. Lincoln Electric is not in a position to warrant or guarantee such advice, and assumes no liability, with respect to such information or advice. We expressly disclaim any warranty of any kind, including any warranty of fitness for any customer's particular purpose, with respect to such information or advice. As a matter of practical consideration, we also cannot assume any responsibility for updating or correcting any such information or advice once it has been given, nor does the provision of information or advice create, expand or alter any warranty with respect to the sale of our products.

Lincoln Electric is a responsive manufacturer, but the selection and use of specific products sold by Lincoln Electric is solely within the control of, and remains the sole responsibility of the customer. Many variables beyond the control of Lincoln Electric affect the results obtained in applying these types of fabrication methods and service requirements.

Subject to Change – This information is accurate to the best of our knowledge at the time of printing. Please refer to [www.lincolnelectric.com](http://www.lincolnelectric.com) for any updated information.



2345 Murphy Blvd.  
Gainesville, GA 30504  
TEL: 866-236-0044