Kaishan Technologies
Rotary Screw Air
Compressor

PK 5-7.5HP
Parts Manual

PN: 97002025000034

Release April 2025, Version: E

(125PSI/150PSI/190PSI/208V/230V/460V/FS/60HZ/BELT/ASME/UL)

TABLE OF CONTENTS

Service Parts	3
Serial Number	3
Fluid Specification	4
Spare Parts	5
Airend and Inlet valve	6
Base Mounting	8
Driving System and Electrical Motor	10
Air Cooler	14
Fluid Piping	16
Cabinet	18
Shaft seal oil return component	20
Electrical Enclosure	22
Decals	30
Standard Terms and Conditions	33
Appendix	36
Contact Information	37

Service Parts

The following information must be provided for ordering service parts:

1. The serial number of unit must be provided. It will be verified to ensure correct replacement parts are ordered.
2. Service parts must be ordered from closest authorized distributor.
3. Exact part number, quantity and delivery method must be provided.

All service parts must be ordered through nearest authorized distributor. Insist on genuine manufacturer parts only. Failure to do so may void product warranty.

Serial Number

The unit serial number can be found on serial number tag, which is located on the cabinet corner post of the unit. The serial number tag is shown as follows.



Fluid Specification

All PK Compressors must use Kaishan Technologies recommended fluid for maintenance.

Spare Parts

Recommended spare parts are shown as follows:

ITEM No.	QTY	PART NUMBER	DESCRIPTION		
1	1	180800-001	Annual Service Kit		

Airend and Inlet valve

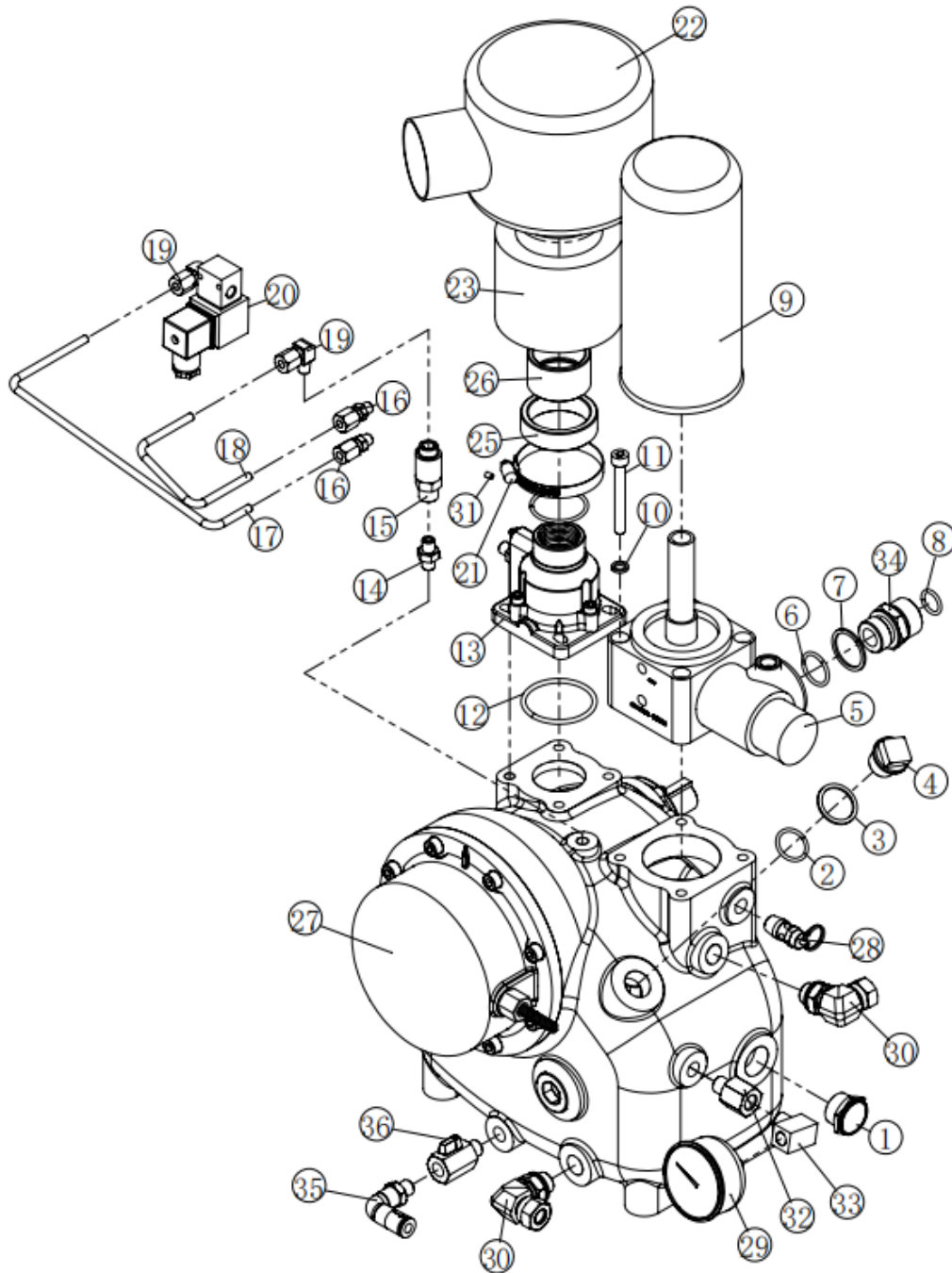

Airend and Inlet valve

NO.	VERSION	PN	DESCRIPTION	QTY	REMARK
1	B01	150599026778	Sight glass	1	
2		120000000048	O ring	1	22.4*2.65
3	B01	150599030155	Fitting washer	1	
4	B01	150599003279	Plug	1	
5	B01	150599029652	Combination valve	1	
6		120000000050	O ring	1	23.6*2.65
7	B01	150599030145	Fitting washer	1	
8		120000000044	O ring	1	16*2.65
9	B01	120902000217	Air/oil separator element	1	
10		100004000011	Washer	1	8
11		100001000097	Screw	1	M8*65
12		120000000113	O ring	1	51.5*3.55
13	B01	120514000037	Inlet valve	1	
14	B01	150599027899	Joint	1	
15	B01	150599004045	Check valve	1	
16	B01	120601000063	Joint	2	
17		150599018821	Air control pipe	1	
18		150599018822	Air control pipe	1	
19	B01	120601000037	Joint	2	
20	B01	120540000003	2/2 NO solenoid valve	1	14bar,2.0
21	B01	121405000020	Hoop	1	
22	B01	120910000113	Air filter shell	1	
23		120901000075	Air filter element	1	
24		120000000062	O ring	1	40*2.65
25	B01	150599002298	Clamp (rubber)	1	
26		150599028503	Connecting pipe	1	
27		1870101	Airend	1	
28	B01	120500000248	ASME safety valve	1	
29	B01	121100000008	Pressure gauge	1	
30		150599043221	Joint	2	G0.375-M18x1.5 Card 12
31		100001000314	Screw	1	M4*6
32	B01	150599035911	Joint	1	NPT0.25-RP0.25
33	B01	150599027997	Joint	1	1/4
34	B01	150599027767	Joint	1	
35		150599043220	Joint	1	
36	B01	120501000027	Ball valve	1	

Base Mounting

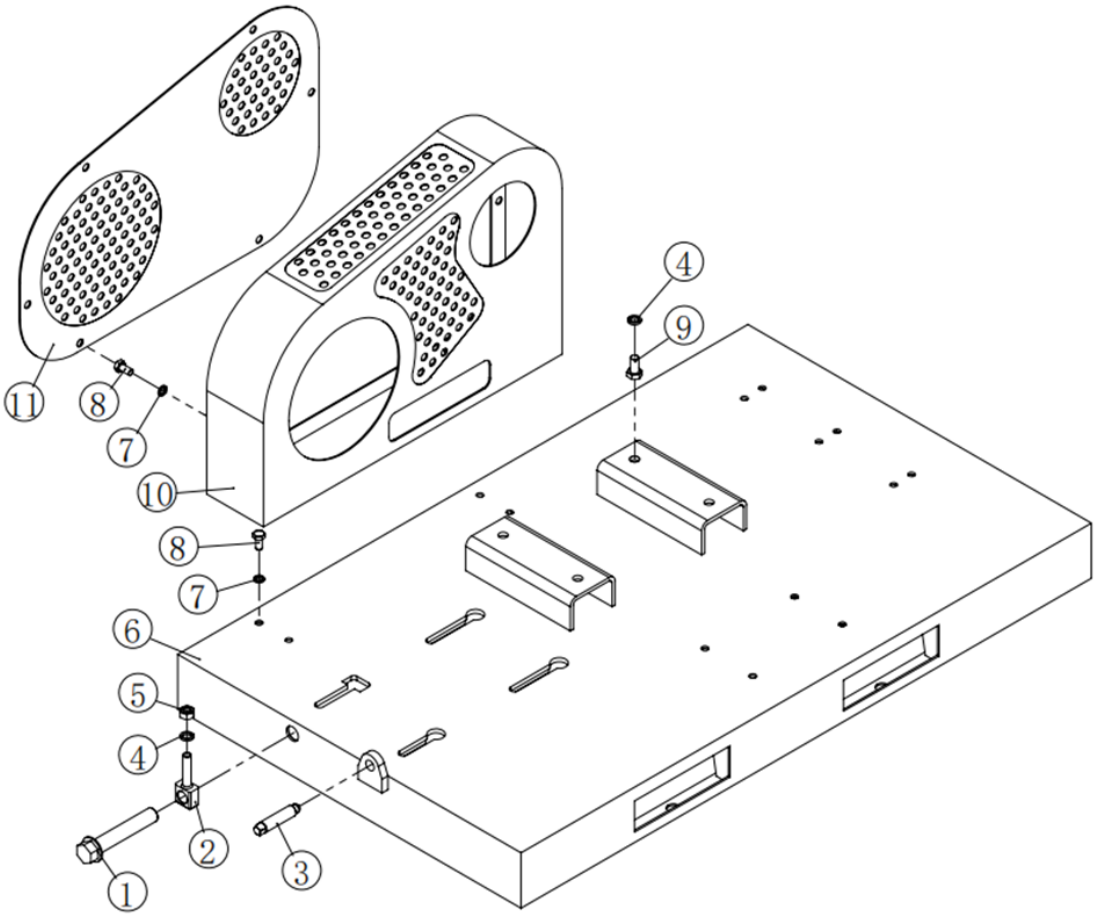

Base Mounting

NO.	VERSION	PN	DESCRIPTION	QTY	REMARK
1	B01	150599026752	Bolt	1	
2	B01	150599022587	Bolt	1	
3	B01	150599022588	Rod	1	
4		100004000014	Washer	2	
5		100003000096	Nut	1	M10
6	S01	150599022593	Base	1	
7		100004000011	Washer	2	8
8		100000000338	Bolt	2	M8*16
9		100000000365	Bolt	1	M10*20
10	S01	150599022592	Safety shield	1	7.5hp
	S01	150599035516	Safety shield	1	5hp
11	S01	150599022594	Safety mesh plate	1	7.5hp
	S01	150599035516	Safety mesh plate	1	5hp

Driving System and Electrical Motor

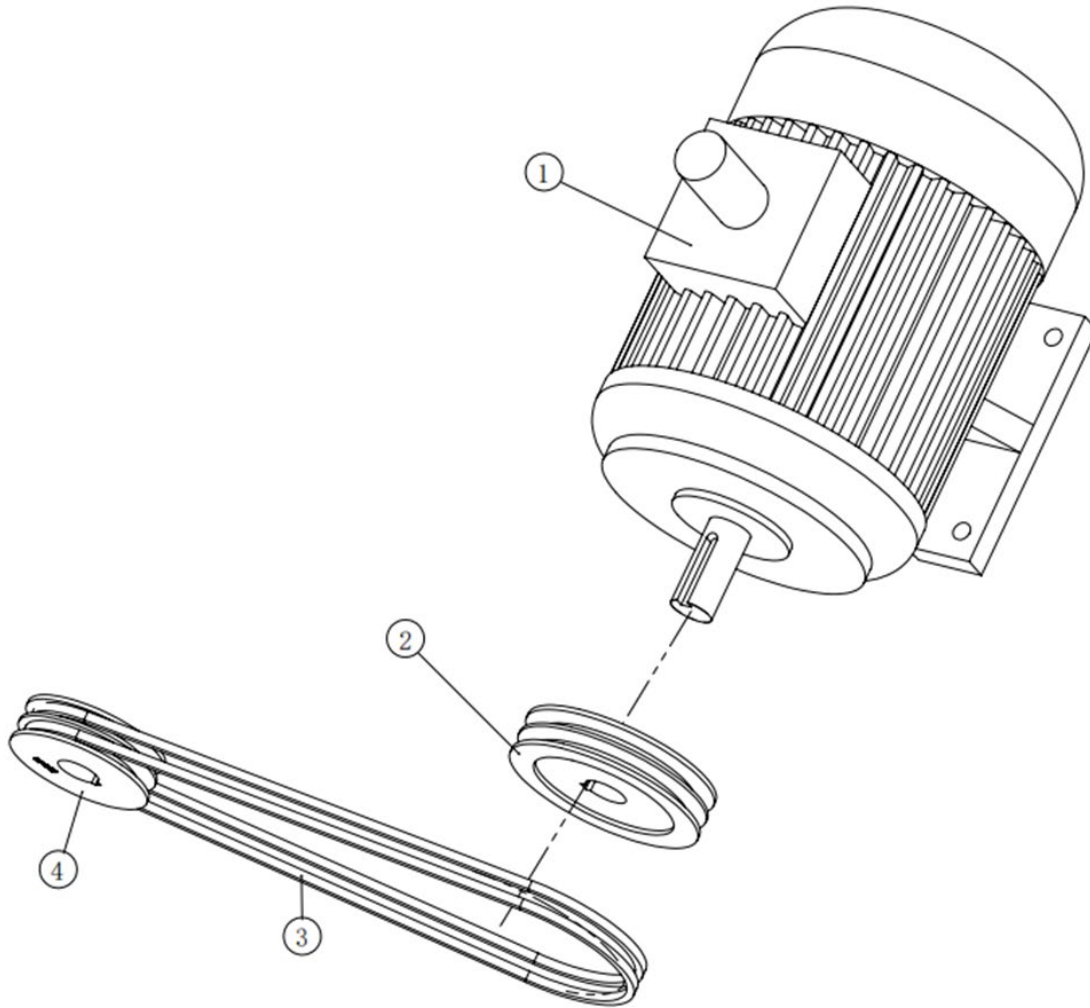

Driving System and Electrical Motor

(3-phase motor)

NO.	VERSION	PN	DESCRIPTION	QTY	REMARK
1	B01	120100000017	WEG motor IE3	1	5HP
	B01	120100000015			7.5HP
2	B01	150599028895	Pulley	1	7.5-125
	B01	150599028869			7.5-150
	B01	150599035514			7.5-190
	B01	150599028835			5-125
	B01	150599028817			5-150
3	S01	150599044565	V-belt	2	5-125
					5-150
					5-190
		150599044577			7.5-125
		150599044576			7.5-150
					7.5-190
4	B01	150599036721	Pulley	1	7.5-125
	B01	150599038707			5-190
	B01	150599035907			5-125
	B01	150599035901			7.5-150
					7.5-190
					5-150

Driving System and Electrical Motor

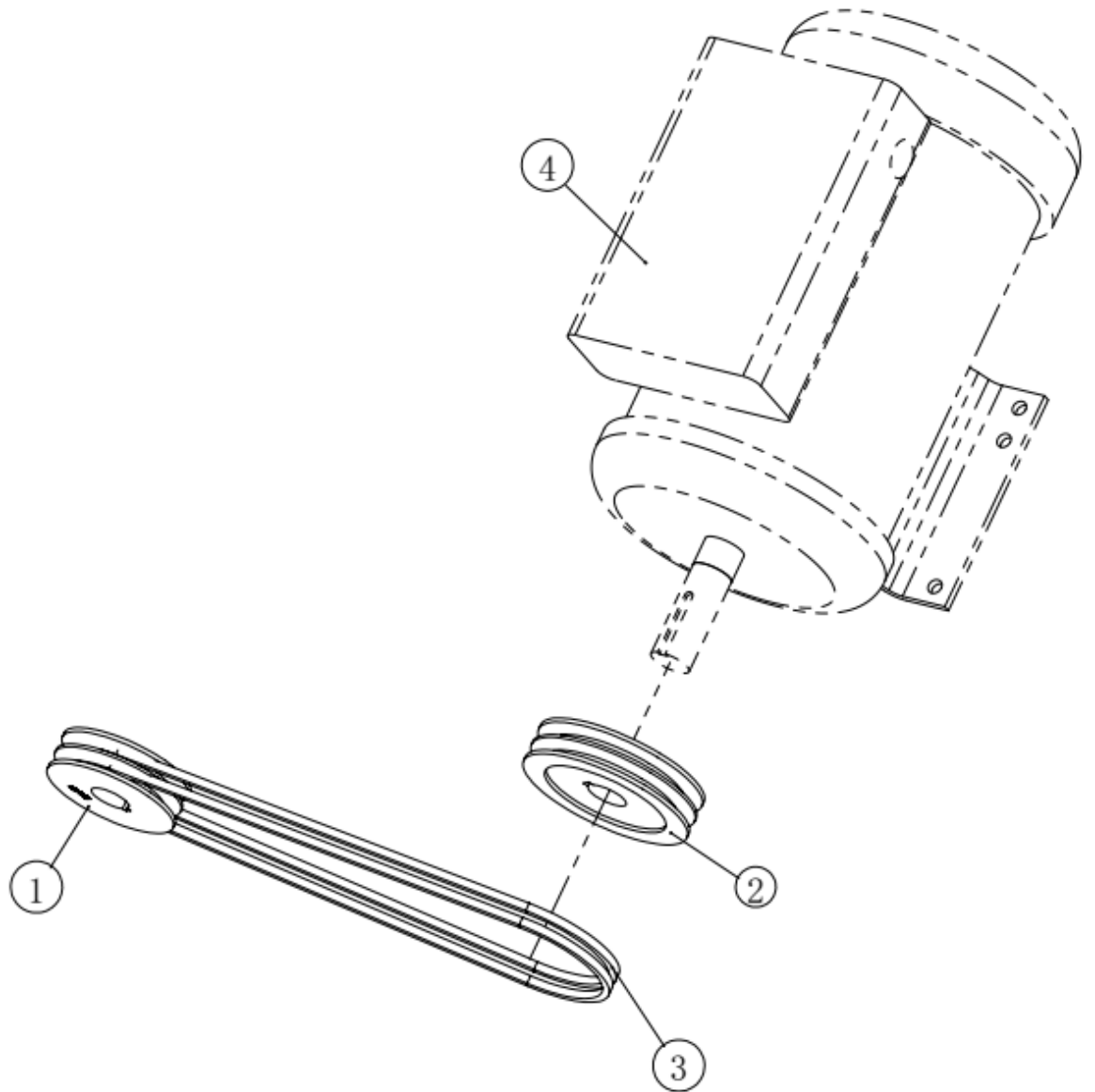

Driving System and Electrical Motor

(single-phase motor)

NO.	VERSION	PN	DESCRIPTION	QTY	REMARK
1	B01	150599035907	Pulley	1	5-125
	B01	150599038707			7.5-150
	B01	150599035513			5-190
	B01	150599035901			7.5-125
2	B01	150599035902	Pulley	1	5-150
	B01	150599035896			5-125
	B01	150599038682			5-190
	B01	150599035903			7.5-190
	B01	150599038678			7.5-150
	B01	150599035904			7.5-125
3	S01	150599044564	V-belt	2	5-125
	S01	150599044565			5-150
4		TEFC36LC	Motor	1	5-190
		TEFC37LC			7.5-190
					7.5-125
					7.5-150
					5HP
					7.5HP

Air Cooler

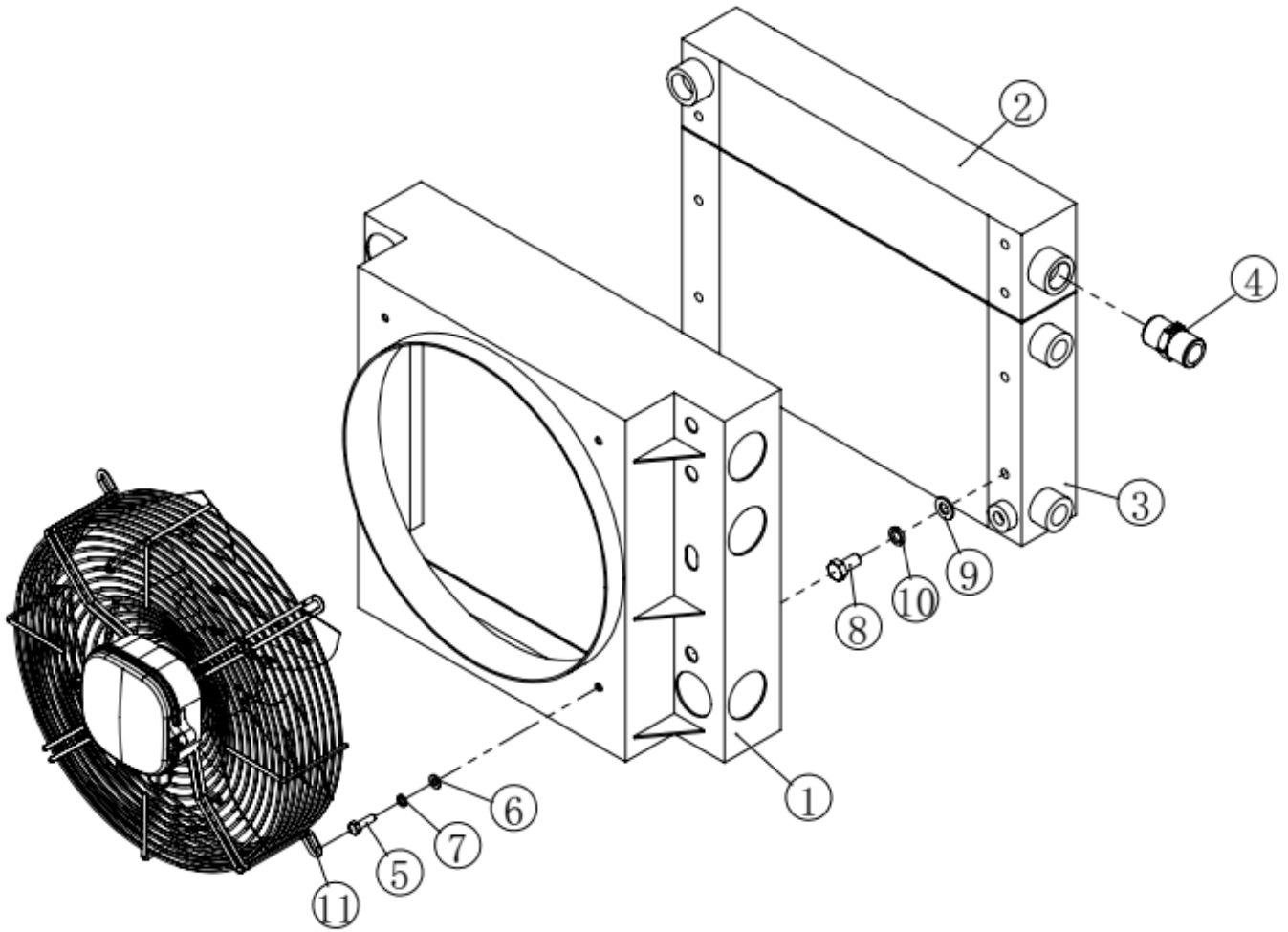

Air Cooler

NO.	VERSION	PN	DESCRIPTION	QTY	REMARK
1	S01	150599022597	Wind scooper	1	
2	S01	150599035912	After cooler	1	
3	S01	150599035913	Oil cooler	1	
4	S01	150599040004	Joint	1	R0.75-NPT0.75
5		100000000318	Bolt	1	M6*20
6		100004000081	Washer	1	6
7		100004000008	Washer	1	6
8		100000000365	Bolt	1	M10*20
9		100004000085	Washer	1	10
10		100004000014	Washer	1	10
11		120800000352	Fan	1	3-phase
	B01	120800000237	Fan	1	Single-phase

Fluid Piping

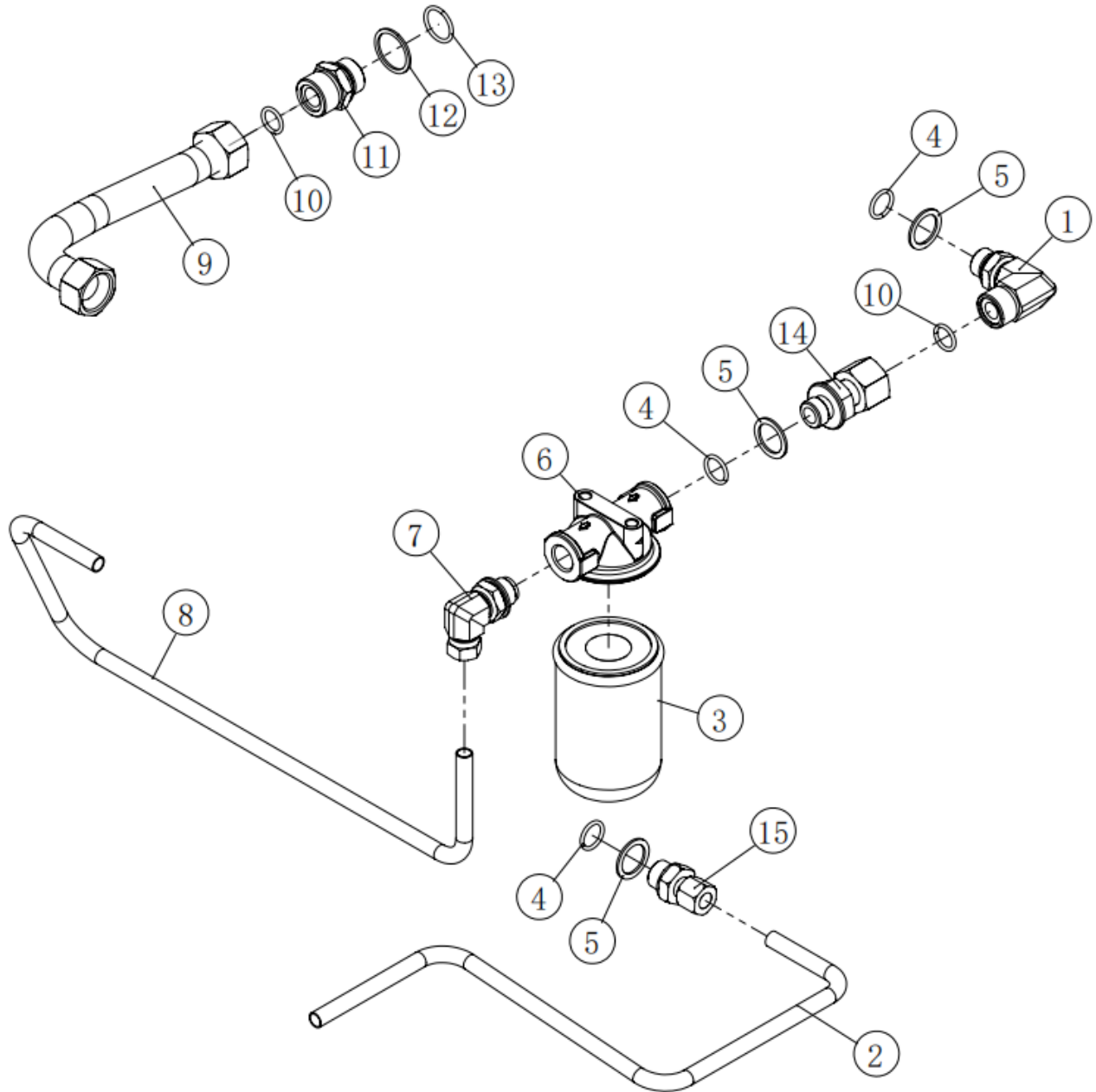

Fluid Piping

NO.	VERSION	PN	DESCRIPTION	QTY	REMARK
1	B01	150599003431	Adjustable elbow	1	G0.5-M27x1.5
2	S01	150599022602	Tank to cooler pipe	1	
3	B01	120904000065	Oil filter	1	
4		120000000045	O ring	3	18*2.65
5	B01	150599030143	Fitting washer	3	
6	B01	120905000084	Oil filter seat	1	
7		150599043222	Joint	1	G0.5-M18x1.5 Card 12
8	S01	150599022603	Oil pipe	1	Oil filter to airend
9	S01	150599022604	Oil pipe	1	MPV to after cooler
10		120000000044	O ring	2	16*2.65
11	B01	150599027767	Joint	1	
12	B01	150599030145	Fitting washer	1	
13		120000000050	O ring	1	23.6*2.65
14	B01	150599028073	Combination joint	1	
15	B01	120601000007	Joint	1	

Cabinet

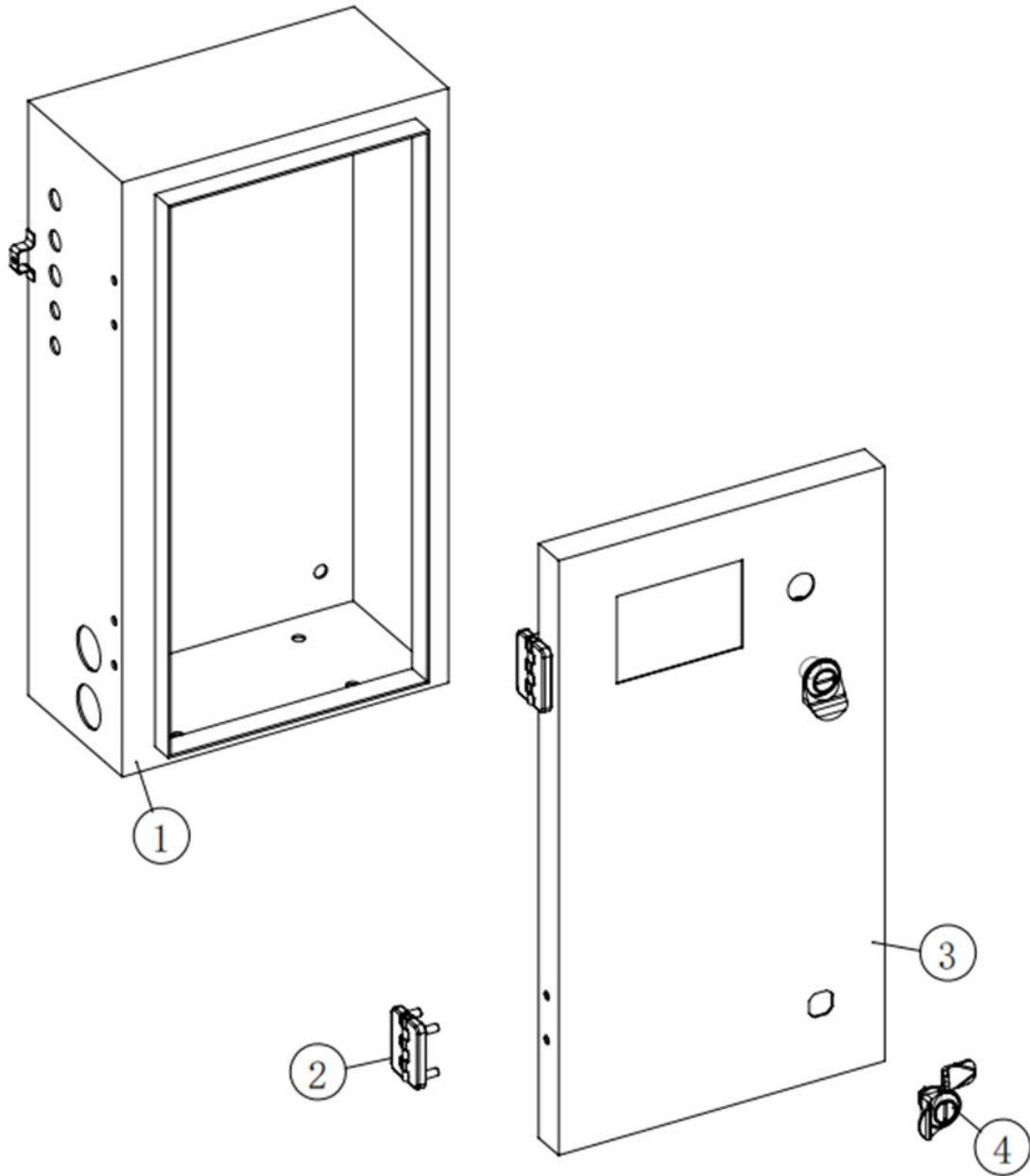

Cabinet

NO.	VERSION	PN	DESCRIPTION	QTY	REMARK
1	S01	150599022605	Electrical box	1	
2	B01	121401000004	Hinge	2	
3	S01	150599022606	Door	1	
4	B01	150599029176	Lock	2	

Shaft seal oil return component

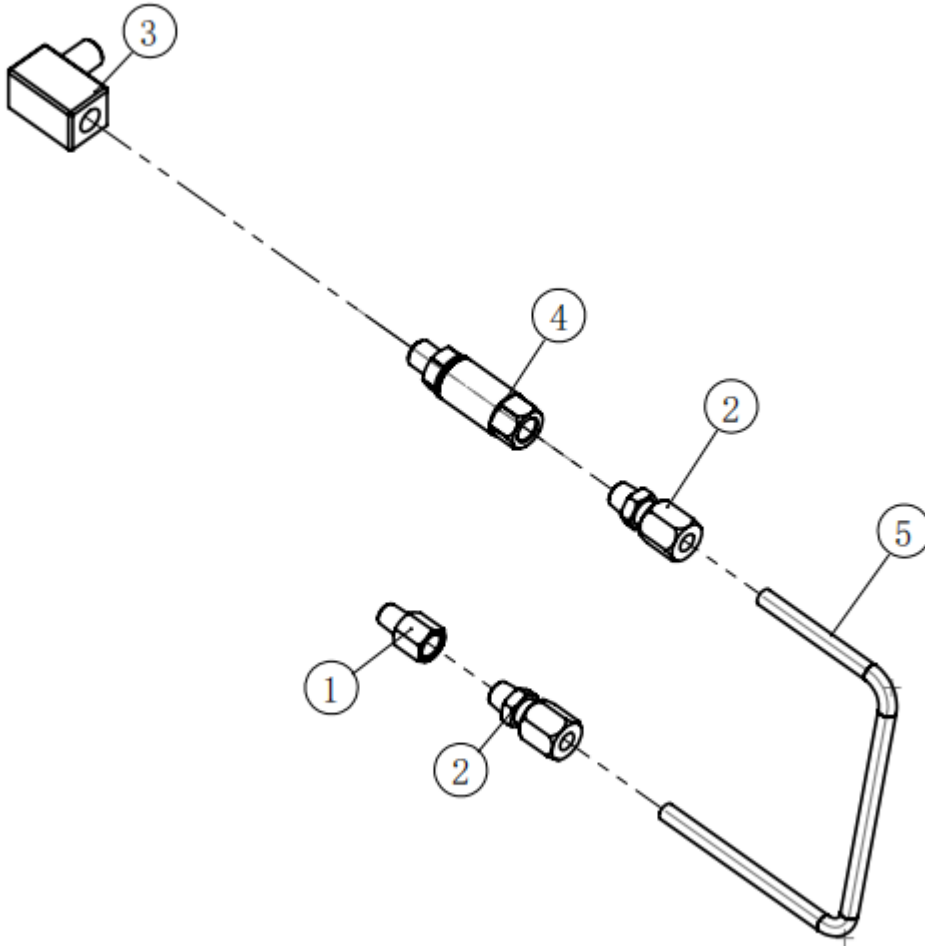

Shaft seal oil return component

NO.	VERSION	PN	DESCRIPTION	QTY	REMARK
1	B01	150599034525	Joint	1	NPT0.0625-R0.125
2	B01	120601000063	Joint	2	
3		150599041296	Elbow	1	
4	B01	150599029628	Check valve	1	
5		150599041241	Shaft seal oil return pipe	1	

Electrical Enclosure

(5HP/3-phase)

NO.	PN	DESCRIPTION	QTY	REMARK
1	121015000010	Terminal block	2	DZ
2	121003000144	Miniature breaker	1	Q1
3	121010003202	Fuse block	1	FU1
4	121005000202	Transformer	1	T
5	121006000166	Thermal overload relay	1	FR1
6	121015000271	Terminal	3	TC1
7	121007000029	Current transformer	1	CT1
8	121000000178	Contactora	1	KM1
9	121015000271	Terminal	3	TC2
10	121014000139	Cable	0.6	BVR
11	121000000182	Contactora	1	KM3
12	121004000685	Controller	1	XSQ
13	121012000044	Emergency stop button	1	JT
14	121101000014	Pressure sensor	1	DP
15	121101000059	Temperature sensor	1	DT
16	121000000182	Contactora	1	KM2
17	121013000056	Grounding copper bar	1	JDTP
18	121015000010	Terminal block	3	DZ1
*20	121011000031	Fuse	1	FU1

Note: * Items are not shown on the drawing.

Electrical Enclosure

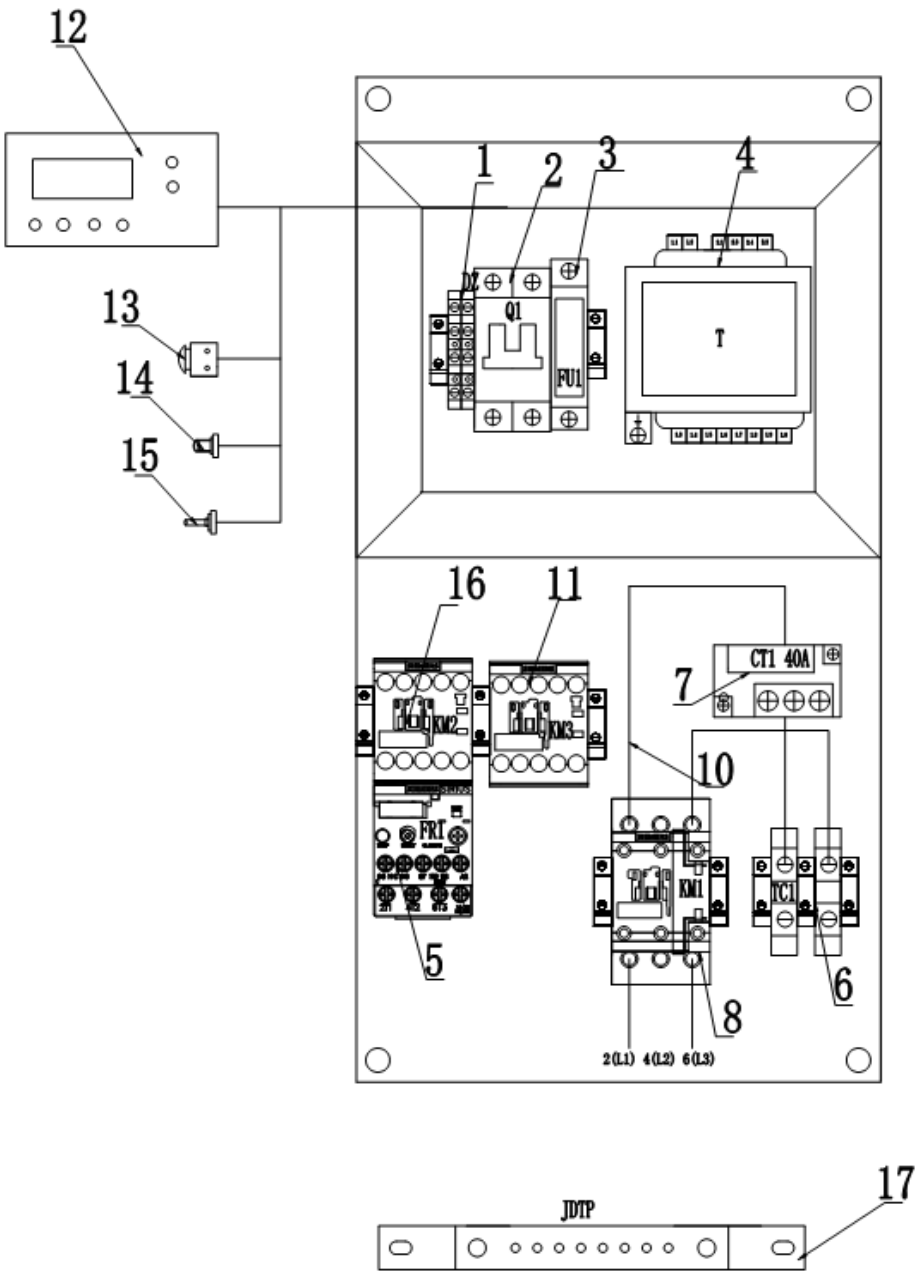

Electrical Enclosure

(5HP/1-phase)

NO.	PN	DESCRIPTION	QTY	REMARK
1	121015000010	Terminal block	2	DZ
2	121003000144	Miniature breaker	1	FU1
3	121010003202	Fuse block	1	Q1
4	121005000202	Transformer	1	T
5	121006000068	Thermal overload relay	1	FR1
6	121015000271	Terminal	2	TC1
7	121007000029	Current transformer	1	CT1
8	121000000018	Contactora	1	KM1
10	121014000129	Cable	0.6	BVR
11	121000000182	Contactora	1	KM3
12	121004000683	Controller	1	XSQ
13	121012000044	Emergency stop button	1	JT
14	121101000014	Pressure sensor	1	DP
15	121101000059	Temperature sensor	1	DT
16	121000000182	Contactora	1	KM2
17	121013000056	Grounding copper bar	1	JDTP
*20	121011000031	Fuse	1	FU1

Note: * Items are not shown on the drawing.

Electrical Enclosure

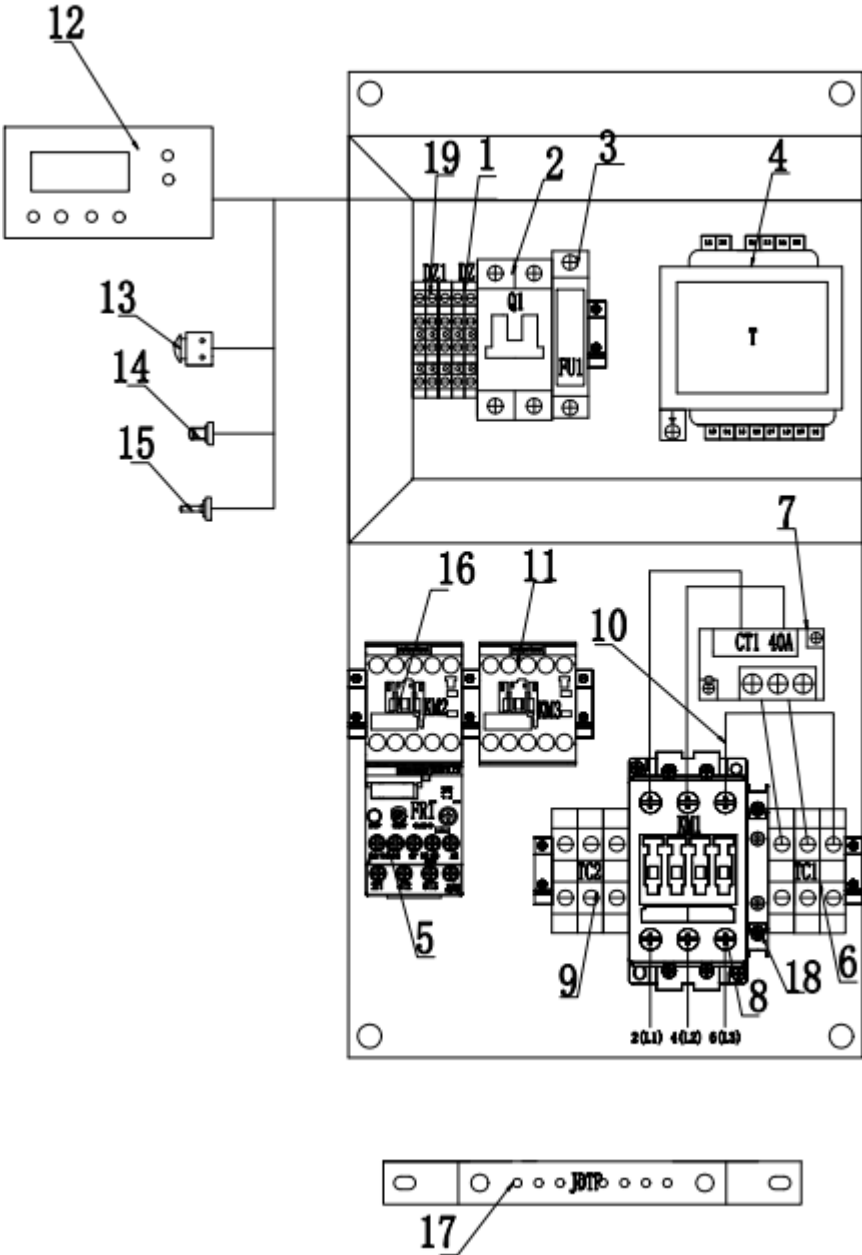

Electrical Enclosure

(7.5HP/3-phase)

NO.	PN	DESCRIPTION	QTY	REMARK
1	121015000010	Terminal block	2	DZ
2	121003000144	Miniature breaker	1	Q1
3	121010003202	Fuse block	1	FU1
4	121005000202	Transformer	1	T
5	121006000166	Thermal overload relay	1	FR1
6	121015000271	Terminal	3	TC1
7	121007000029	Current transformer	1	CT1
8	121000000018	Contact	1	KM1
9	121015000271	Terminal	3	TC2
10	121014000129	Cable	0.6	BVR
11	121000000182	Contact	1	KM3
12	121004000683	Controller	1	XSQ
13	121012000044	Emergency stop button	1	JT
14	121101000014	Pressure sensor	1	DP
15	121101000059	Temperature sensor	1	DT
16	121000000182	Contact	1	KM2
17	121013000056	Grounding copper bar	1	JDTP
18	121000000265	Auxiliary contact	1	FZ
19	121015000010	Terminal block	3	DZ1
*20	121011000031	Fuse	1	FU1
*21	121025000186	Short circuit bar	1	DS

Note: * Items are not shown on the drawing.

Electrical Enclosure

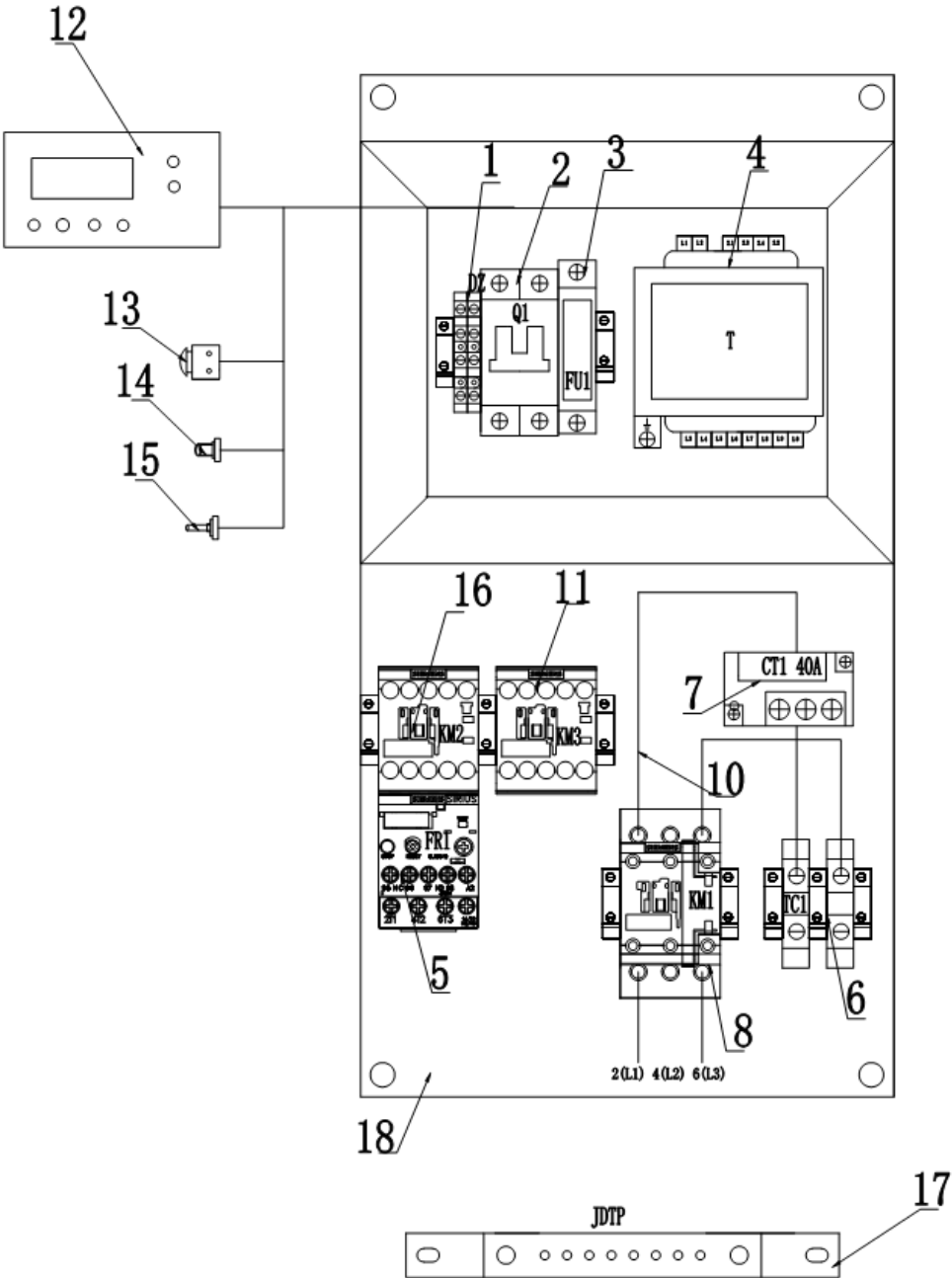

Electrical Enclosure

(7.5HP/1-phase)

NO.	PN	DESCRIPTION	QTY	REMARK
1	121015000010	Terminal block	2	DZ
2	121003000144	Fuse block	1	Q1
3	121010003202	Fuse block	1	FU1
4	121005000202	Transformer	1	T
5	121006000068	Thermal overload relay	1	FR1
6	121015000271	Terminal	2	TC1
7	121007000029	Current transformer	1	CT1
8	121000000186	Contactactor	1	KM1
10	121014000122	Cable	0.4	BVR
11	121000000182	Contactactor	1	KM3
12	121004000683	Controller	1	XSQ
13	121012000044	Emergency stop button	1	JT
14	121101000014	Pressure sensor	1	DP
15	121101000059	Temperature sensor	1	DT
16	121000000182	Contactactor	1	KM2
17	121013000056	Grounding copper bar	1	JDTP
*20	121011000031	Fuse	1	FU1

Note: * Items are not shown on the drawing.

Decals

Decals information is shown as following.



Decals



NOTE:

1. DECALS P/N : 142939

Decals

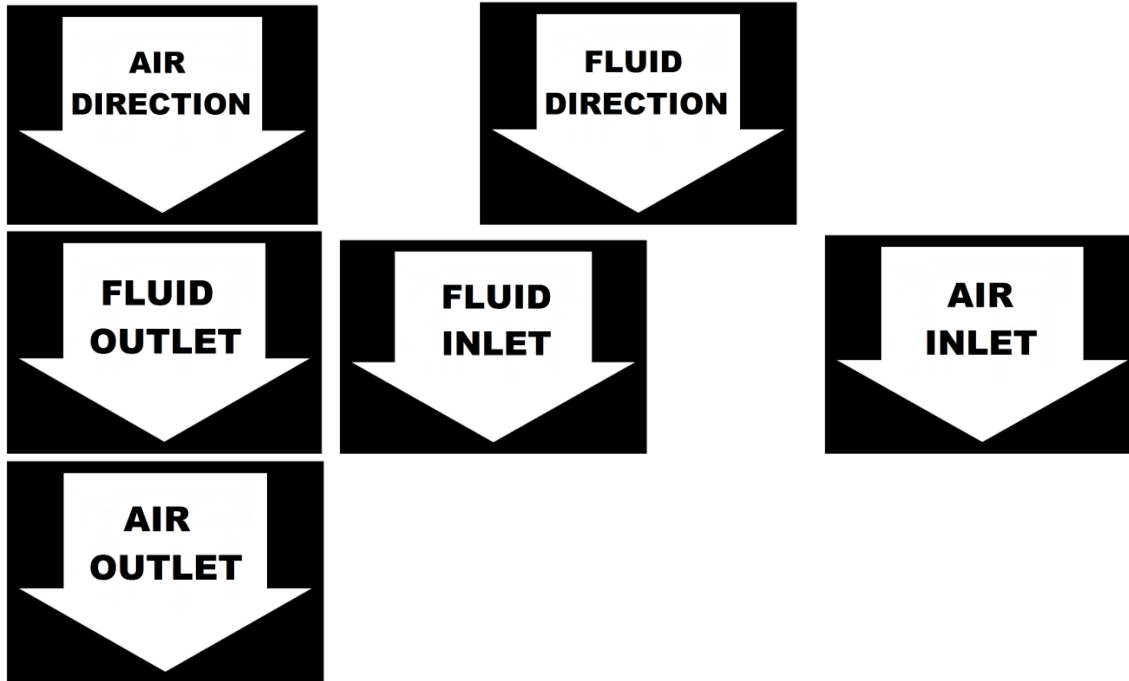

NOTE:

1. DECALS P/N : 142939

Standard Terms and Conditions

These terms and conditions govern the sale of Products ("Rotary Screw Air Compressors and parts") and provisions of services by Kaishan Technologies Compressor Co. Ltd (Seller) and its authorized representative or buyer. These terms and conditions ("Agreement") take precedence over Buyer' s supplemental or conflicting terms and conditions to which notice of objection is hereby given. Neither Seller' s commencement of performance or delivery shall be deemed or construed as acceptance of Buyer' s supplemental or conflicting terms and conditions. Kaishan Technologies Compressor' s failure to object to conflicting or additional terms will not change or add to the terms of this agreement. Buyer' s acceptance of the Products and/or Services from Seller shall be deemed to constitute acceptance of the terms and conditions contained herein.

Orders: All orders placed by Buyer are subject to acceptance by Seller. Orders may not be canceled or rescheduled without Seller' s written consent. All orders must identify the products, unit quantities, part numbers, applicable prices and requested delivery dates of the Products being purchased. Seller may at its sole discretion allocate Product among its Buyer. Seller may designate certain Products and Services as non-cancelable, non-returnable and the sale of such Products shall be subject to the special terms and conditions contained in Seller' s Customer Acknowledgement or Non-Returnable Product Form, which shall prevail and supersede any inconsistent terms and conditions contained herein or elsewhere.

Prices: The prices of the Products are those prices specified on the front of the invoice or contained within an agreed written contract. Price quotations shall automatically expire in thirty (30) days from the date issued, or as otherwise stated in the quotation.

Taxes: Unless otherwise agreed to in writing by Seller, all prices quoted are exclusive of transportation and insurance costs, duties, and all taxes including federal, state and local sales, excise and value added, goods and services taxes, and any other taxes. Buyer agrees to indemnify and hold Seller harmless for any liability for tax in connection with the sale, as well as the collection or withholding thereof, including penalties and interest thereon. When applicable, transportation and taxes shall appear as separate items on Seller' s invoice.

Payment: Payment may be made by check, money order, credit card, or wire transfer (all fees are borne by the Buyer). Where Seller has extended credit to Buyer, terms of payment shall be net thirty (30) days from date of invoice, without offset or deduction. On any past due invoice, Seller may impose a monthly interest rate. If Buyer fails to make the required payments the Seller will impose the interest rate each month. If Buyer fails to make each payment when it is due, Seller reserves the right to withdraw credit and thereby suspend or cancel performance under any or all purchase orders or agreements in which Seller has extended credit to Buyer. In the event of default by Buyer, Seller shall be entitled to costs, fees, and expenses including but not limited to recovery of attorney fees, court costs and fees, and collections costs.

Standard Terms and Conditions

Delivery and Title: The locations of shipment delivery will be made according to the Seller and Buyer agreement. Title and risk of loss pass to the Buyer upon delivery of the Product to the carrier. Seller's delivery dates are estimates only and Seller is not liable for delays in delivery or for failure to perform due to causes beyond the reasonable control of the Seller, nor shall the carrier be deemed an agent of the Seller. A delayed delivery of any part of an Order does not entitle Buyer to cancel other deliveries. Kaishan Technologies Compressor will comply with various federal, state and local laws and regulation concerning occupational health, safety and environment concerns. Buyer has full responsibility to comply with those laws and regulations during the installation and operation of the equipment.

Acceptance / Returns: Shipments will be deemed to have been accepted by Buyer upon delivery of the said shipments to Buyer unless rejected upon receipt. Buyer shall perform all inspections and tests. Buyer deems necessary as promptly as possible but in no event later than 7 days after receipt of Products, at which time Buyer will be deemed to have irrevocably accepted the Products. Any discrepancy in shipment quantity must be reported within 7 days after receipt of Products. Buyer may not return Products without a Return Material Authorization ("RMA") number. RMA's valid for 30 days from the date issued.

Standard Warranty: Buyer will honor Product warranties and indemnities authorized by the manufacturer, including any transferable. 90 days warranty is given for service parts from receipt date. Seller warrants to Buyer that Products purchased hereunder will conform to the applicable manufacturer's specifications for such products and that any value-added work performed by Seller on such Products will conform to applicable Buyer's specifications. If Seller breaches this warranty, Buyer's remedy is limited to (at Seller's election) (1) refund of Buyer's purchase price for such Product (without interest), (2) repair of such Products, or (3) replacement of such Products provided that such Products must be returned to Seller, along with acceptable evidence of purchase within 13 days from date of delivery, transportation charges prepaid. No warranty will apply if the Product has been subject to misuse, neglect, accident or modification.

Limitation of Liabilities: Buyer shall not be entitled to, and Seller shall not be liable for, loss of profit or revenue, promotional or manufacturing expenses, overheads expenses, business interruption cost, loss of data, removal or reinstallation costs, injury to reputation of buyer, punitive damages, loss of contractor orders or any indirect, special, incidental or consequential damages of any nature. Buyer's recovery from seller for any claim shall not exceed the purchase price paid for the affected products irrespective of the nature of the claim whether in contract, tort, warranty, or otherwise. Buyer will indemnify, defend and hold seller harmless from any claims based on (a) Seller's compliance with buyer's designs, specifications, or instructions, (b) Modification of any products by anyone other than Seller, or (c) use in combination with other products not supplied by seller.

Standard Terms and Conditions

Use of Products: Unless otherwise specified. Products sold by Seller are not designed, intended or authorized for use in life support, life sustaining, nuclear, or other applications in which the failure of such Products could reasonably be expected to result in personal injury, loss of life or catastrophic property damage. If buyer uses or sales the Products for use in any such applications: (1) Buyer acknowledges that such use or sale is at Buyer' s sole risk; (2) Buyer agrees that Seller and the manufacturer of the Products are not liable, in whole or in part, for any claim or damage arising from such use; and (3) Buyer agrees to indemnify, defend and hold Seller and the manufacturer of the Products harmless from and against any and all claims, damages, losses, costs, expenses and liabilities arising out of or in connection with such use or sale.

Force Majeure: Seller is not liable for failure to fulfill its obligations for any accepted Order or for delays in delivery due to causes beyond Seller' s reasonable control including, but not limited to, acts of God, natural or artificial disaster, riot, war, strike, delay by carrier, shortage of Product, acts or omissions of other parties, acts or omissions of civil or military authority, Government priorities, changes in law, material shortages, fire, strikes, floods, epidemics, quarantine restrictions, acts of terrorism, delays in transportation or inability to obtain labor, materials or products through its regular sources, which shall be considered as an event of force majeure excusing Seller from performance and barring remedies for non-performance. In an event of force majeure condition, the Seller' s time for performance shall be extended for a period equal to the time lost as a consequence of the force majeure condition without subjecting Seller to any liability or penalty. Seller may, at its option, cancel the remaining performance, without any liability or penalty, by giving notice of such cancellation to the Buyer.

General: (a) Seller will comply with state law for any dispute from buyer. (b) Buyer may not assign this Agreement without the prior written consent of Seller. Seller or its affiliates may perform the obligations under this Agreement. This Agreement is binding on successor and assigns, (c) Products, including software or other intellectual property, are subject to any applicable rights of third parties, such as patents, copyrights and/or user licenses.

Appendix

(If your machine is standard, this page is blank.)

Contact Information

Kaishan Compressor, LLC.,
Add.: 15445 Industrial Park Dr. Loxley, AL, Post code: 36551
Office number: +1 251-202-0577
KaishanUSA.com