

# KLUTCH™

## Battery-Powered Stick Welder, 120 Amp

### Owner's Manual

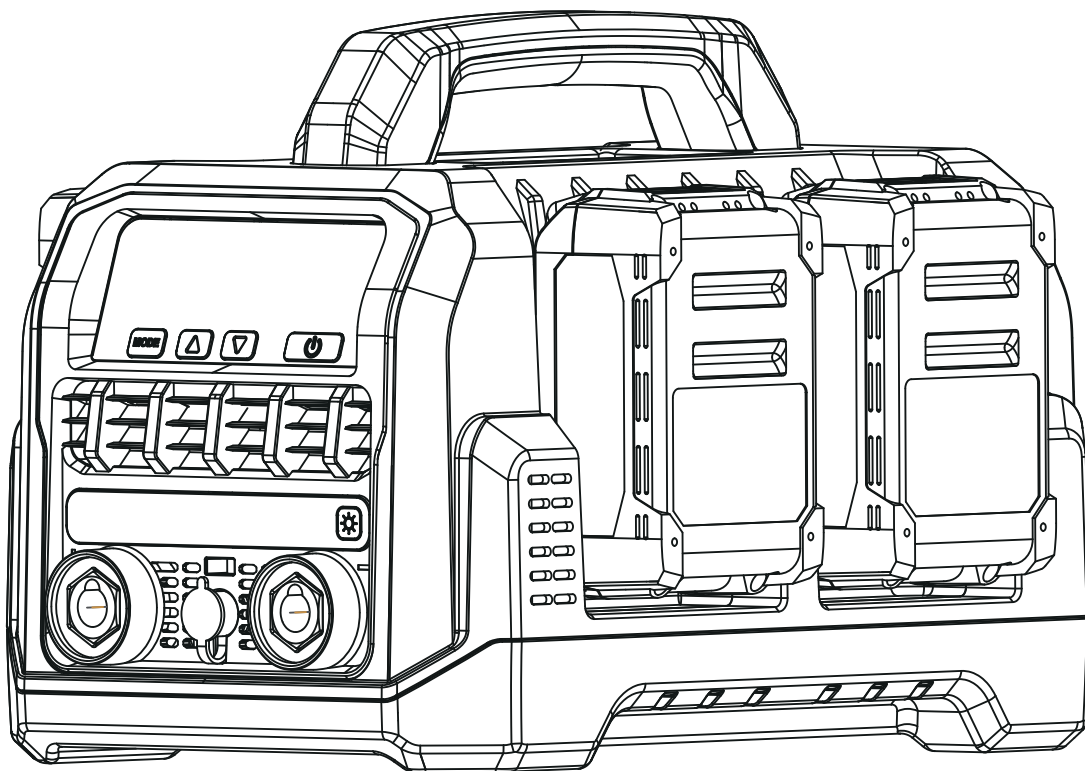

**⚠ WARNING:** Read carefully and understand all ASSEMBLY AND OPERATION INSTRUCTIONS before operating. Failure to follow the safety rules and other basic safety precautions may result in serious personal injury.

**Item # 6651752**

**READ & SAVE THESE INSTRUCTIONS**

Thank you very much for choosing a KLUTCH. product!

For future reference, please complete the owner's record below:

Serial Number/Lot Date Code: \_\_\_\_\_

Purchase Date: \_\_\_\_\_

Save the receipt, warranty, and this manual. It is important that you read the entire manual to become familiar with this product before you begin using it.

This WELDING MACHINE is designed for certain applications only. Northern Tool and Equipment is not responsible for issues arising from modification or improper use of this product such as an application for which it was not designed. We strongly recommend that this product not be modified and/or used for any application other than that for which it was designed.

For technical questions, please call **1-800-222-5381**.

# IMPORTANT SAFETY INSTRUCTIONS

## WORK AREA

- 1. Keep your work area clean and well lit.** Cluttered benches and dark areas invite accidents.
- 2. Do not operate power tools in explosive atmospheres, such as in the presence of flammable liquids, gases, or dust.** Power tools create sparks which may ignite the dust or fumes.
- 3. Keep bystanders, children, and visitors away while operating a power tool.** Distractions can cause you to lose control. Protect others in the work area from debris such as chips and sparks. Provide barriers or shields as needed.

## PERSONAL SAFETY

- 4. Stay alert, watch what you are doing, and use common sense when operating a power tool. Do not use tool while tired or under the influence of drugs, alcohol, or medication.** A moment of inattention while operating power tools may result in serious personal injury.
- 5. Dress properly. Do not wear loose clothing or jewelry. Tie up long hair. Keep your hair, clothing, and gloves away from moving parts.** Loose clothes, jewelry, or long hair can be caught by moving parts.
- 6. Avoid accidental starting. Be sure switch is off before plugging in.** Carrying tools with your finger on the switch or plugging in tools with the switch on invites accidents.
- 7. Remove adjusting keys before turning the tool on.** A wrench or a key that is left attached to a rotating part of the tool may result in personal injury.
- 8. Do not overreach. Keep proper footing and balance at all times.** Proper footing and balance enable better control of the tool in unexpected situations.
- 9. Use safety equipment. Always wear eye protection.** Dust mask, non-skid safety shoes, hard hat, or hearing protection must be used in appropriate conditions.

# IMPORTANT SAFETY INSTRUCTIONS

## BATTERY TOOL USE AND CARE

- 10. Ensure the switch is in the off position before inserting the battery pack.**  
Inserting the battery pack into power tools that have the switch on may cause an accident.
- 11. Recharge only with the charger specified by the manufacturer.** A charger that is suitable for one type of battery pack may create a risk of fire when used with another battery pack.
- 12. Use power tools only with specifically designed battery packs.** Use of any other battery packs may create a risk of injury or fire.
- 13. When battery pack is not in use, keep it away from other metal objects** like paper clips, coins, keys, nails, screws, or other small metal objects that can make a connection from one terminal to another. Shorting the terminals together may cause burns or a fire.
  - a. Do not use the tool in wet or damp conditions.
  - b. Always keep the work area free of tripping hazards.
  - c. When using the tool, always ensure you are wearing protective safety equipment including safety glasses/goggles, ear muffs, dust masks and other protective clothing including gloves and aprons.
- 14. Under abusive conditions, liquid may be ejected from the battery - do avoid contacting.** If contact accidentally occurs, flush with water. If liquid contacts eyes, additionally seek medical help. Liquid ejected from the battery may cause irritation or burns.

## SERVICE

- 15. Tool service must be performed only by qualified repair personnel.** Service or maintenance performed by unqualified personnel could result in a risk of injury.
- 16. When servicing a tool, use only identical replacement parts. Follow instructions in the Maintenance section of this manual.** Use of unauthorized parts or failure to follow maintenance instructions may create a risk of electric shock or injury.

# SAFETY INSTRUCTIONS FOR WELDING MACHINE

- **Keep out of reach of children. Keep children and bystanders away while operating.**
- **Place the welder in a stable location before use. If it falls while plugged in, severe injury, electric shock, or fire may result.**
- **Do not overreach. Keep proper footing and balance at all times.**
- **Stay alert, watch what you are doing and use common sense when operating a welder. Do not use a welder while you are tired or under the influence of drugs, alcohol or medication. A moment of inattention while operating on the welders may result in serious personal injury.**
- **Avoid unintentional starting. Make sure you are prepared to begin work before turning on the Welder.**
- **Never leave the welder unattended while energized. Turn the power off if you have to leave.**
- **Disconnect the plug or remove the battery pack from tool and place the switch in the locked or “OFF” position before making any assembly adjustments, changing accessories, performing any inspection, maintenance or cleaning procedures.** Such preventive safety measures reduce the risk of starting the tool accidentally.
- **Do not use the welding machine if it has been damaged, left outdoors in the rain, snow, wet or damp environments, or immersed in liquid.**

# SAFETY INSTRUCTIONS FOR BATTERIES AND CHARGER

## BATTERY

1. Never attempt to open or modify battery for any reason. Released electrolyte is corrosive and may cause damage to eyes and skin. It may be toxic if swallowed.
2. Under extreme conditions, battery leakage may occur. When you notice liquid on the battery, proceed as follows:
  - Carefully wipe the liquid off using a cloth. Avoid skin contact.
  - In case of skin or eye contact, follow the instructions below.
  - The battery fluid, a 25-30% solution of potassium hydroxide, can be harmful. In case of skin contact, immediately rinse with water. Neutralize with a mild acid such as lemon juice or vinegar. In case of eye contact, rinse abundantly with clean water for at least 10 minutes.
3. Do not expose to water.
4. Do not store in locations where the temperature may exceed 40°C (104°F).
5. Charge at room temperature: 0°C - 45°C (0°F-140.6°F). It is normal for the battery charger to hum and be warm but not hot during operation.
6. Before charging, make sure that the battery is dry and clean.
7. Exercise care in handling and storing batteries in order not to short them with conductive materials such as rings, keys, coins. There is a real risk of the battery or the conductor overheating, causing fire or burns.
8. Do not dispose of battery on fire. It may explode. Follow instructions and regulations given by local authorities concerning environmental protection. Dispose of old batteries at an appropriate waste disposal facility.

## CHARGER

1. Use only KLUTCH charger to charge KLUTCH 20V Lithium-ion batteries. Other batteries could burst, causing personal injury and damage.
2. Never attempt to charge a non-rechargeable battery.
3. Have damaged cords replaced immediately.
4. Do not expose to water.
5. Do not open the charger.
6. Indoor use only. Do not recharge the battery in the rain or in wet conditions.

# SPECIFICATIONS

- Input Battery voltage: 4x20V
- Current range: 5-120A
- Max. Welding Wire Diameter (inch): 0.094(2.4mm)

# FUNCTIONAL DESCRIPTION

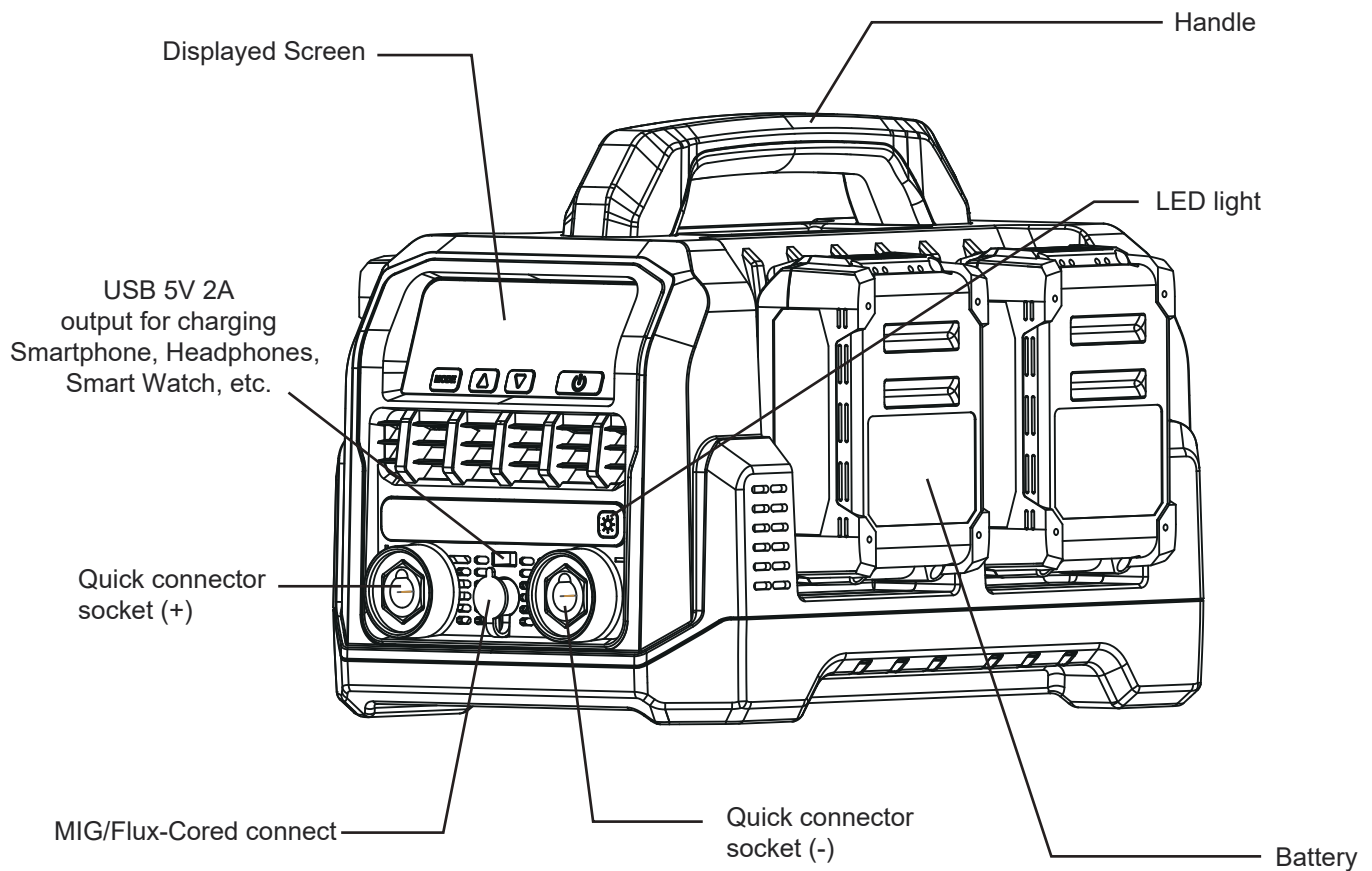

# OPERATION

## How to charge the battery pack ?

### CHARGING BATTERIES

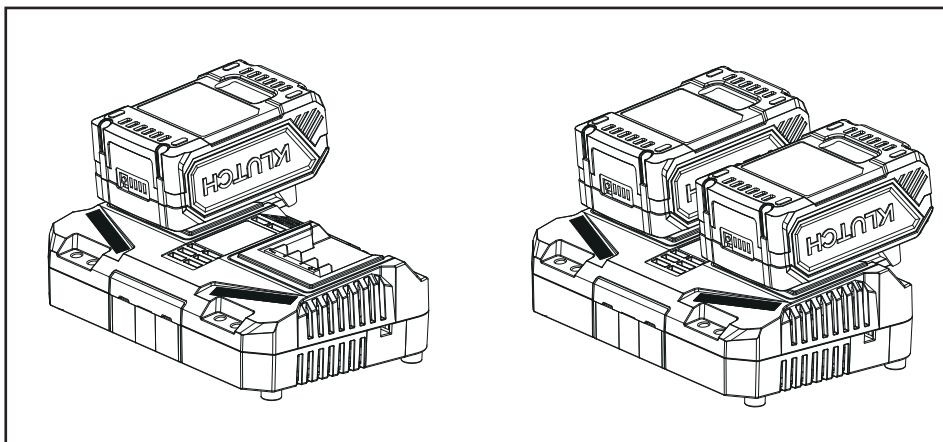

- Place the Battery Pack on a dry fireproof surface in a room where the temperature is from 50° F to 104° F.  
**Note:** If recharging a newly spent Battery Pack, allow it to cool completely before charging.
- Examine the Battery Pack it must be an undamaged 20V lithium-ion type Battery Pack.  
Do not charge a cracked, open, or leaking Battery Pack, or charge a non-recommended type of Battery Pack.

# OPERATION

- Make sure the power supply is normal household voltage, 120 volts, AC only, 60Hz.
- Connect the charger to a power supply.
- Slide the Battery Pack onto the Charger.
- The battery pack may become slightly warm to the touch while charging. This is normal and does not indicate a problem.
- After charging is complete, the green LED will remain on while the charger is in Maintenance mode.
- Charger will periodically wake from Energy Save mode to ensure the battery pack remains in a fully charged state.
- To remove the battery pack from the charger, depress the latches on the top of the battery pack and separate battery from charger.

## CHARGING A HOT BATTERY PACK

- When using a tool continuously, the battery pack may become hot. A hot battery pack may be placed directly onto the charger port but charging will not begin until the battery temperature cools to within acceptable temperature range. When a hot battery pack is placed on the charger, the red LED will begin flashing. When the battery pack cools, the charger will automatically begin charging.

### The LED lights on charger show different status as below

LED FUNCTIONS			
RED LED	GREEN LED	STATUS	ACTION
Off	On	Power	Ready to charge battery pack.
Off	Flashing	Charging	Battery is being charged.
Off	On	Fully charged	Disconnect charger from power supply and remove battery pack from charger.
Flashing	Off	Hot battery	The charger will recover to charge when the temperature drops to 104° F (40°C).
On	Off	Battery defective	Battery pack or charger is defective

### Caution

- Fully charge battery before first use.
- Avoid short periods of charging. Only charge battery pack when it completely runs out.
- In order to extend the battery life, fully charge it after each use and ensure that it is charged every three months; avoid storing batteries in cold places as low temperatures may cause them to fail.

## Install or remove battery pack

**To install:** slide battery pack into the machine until you hear a click.

Make sure that the latch is in place and battery is secure before operation.

**To remove:** Press the battery release latch and pull the battery pack out at the same time.

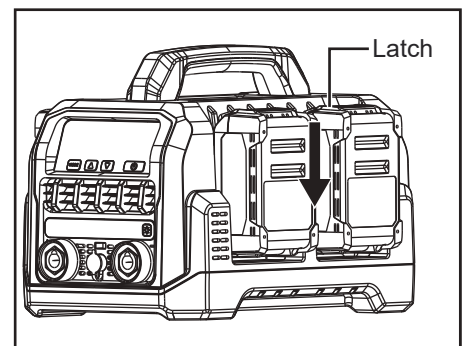

**WARNING:** When the machine is obstructed, please turn off the switch right away and check if the work piece is right. An obstruction may cause the machine motor to burn out.



# OPERATION

1. Make sure that the welder vent is not covered and blocked, so as not to prevent the cooling system from failing.
2. Slide the battery pack into the tool until you hear a click. Turn on the power (Fig.1), the power display light is on, and when it is confirmed that the battery power is sufficient, press the MODE key to adjust to the parameters required for welding.



3. Connect the ground clamp to the "-" pole on the machine and check whether the connection is secure (Fig.2).
4. Connect the electrode holder wire to the "+" pole on the machine and check whether the connection is secure (Fig.3).



5. Clamp the welding clamp onto the electrode (Fig.4) and start welding (Fig.5).



# REPLACEMENT PARTS

- For replacement parts and technical questions, please call Customer Service at 1-800-222-5381.
- Not all product components are available for replacement. The illustrations provided are a convenient reference to the location and position of parts in the assembly sequence.
- When ordering parts, the following information will be required: item description, item model number, item serial number/item lot date code, and the replacement part reference number.
- The distributor reserves the rights to make design changes and improvements to product lines and manuals without notice.

# LIMITED WARRANTY

## Limited Warranty

- Northern Tool and Equipment Company, Inc. (“We” or “Us”) warrants to the original purchaser only (“You” or Your”) that the KLUTCH product purchased will be free from material defects in both materials and workmanship; normal wear and tear excepted, for a period of one year from date of purchase. The foregoing warranty is valid only if the installation and use of the product is strictly in accordance with product instructions. There are no other warranties, express or implied, including the warranty of merchantability or fitness for a particular purpose. If the product does not comply with this limited warranty, Your sole and exclusive remedy is that We will, at our sole option and within a commercially reasonable time, either replace the product or product component without charge to You or refund the purchase price (less shipping). This limited warranty is not transferable.

## Limitations on the Warranty

- This limited warranty does not cover: (a) normal wear and tear; (b) damage through abuse, neglect, misuse, or as a result of any accident or in any other manner; (c) damage from misapplication, overloading, or improper installation; (d) improper maintenance and repair; and (e) product alteration in any manner by anyone other than Us with the sole exception of alterations made pursuant to product instructions and in a workmanlike manner.

## Obligations of Purchaser

- You must retain Your product purchase receipt to verify date of purchase and that You are the original purchaser. To make a warranty claim, contact Us at 1-866-915-8626, identify the product by make and model number, and follow the claim instructions that will be provided. The product and the purchase receipt must be provided to Us in order to process Your warranty claim. Any returned product that is replaced or refunded by Us becomes our property. You will be responsible for return shipping costs or costs related to Your return visit to a retail store.

## Remedy Limits

- Product replacement or a refund of the purchase price is Your sole remedy under this limited warranty or any other warranty related to the product. We shall not be liable for service or labor charges or damage to Your property incurred in removing or replacing the product; any damages, including, without limitation, damages to tangible personal property or personal injury, related to Your improper use, installation or maintenance of the product or product component; or any indirect, incidental or consequential damages of any kind for any reason.

# LIMITED WARRANTY

## **Assumption of Risk**

- You acknowledge and agree that any use of the product for any purpose other than the specified use (s) stated in the product instruction is at Your own risk.

## **Governing Law**

- This limited warranty gives You specific legal rights, and You also may have other rights which vary from State to State. Some states do not allow limitations or exclusions on implied warranties or incidental or consequential damages. So, the above limitations may not apply to You. This limited warranty is governed by the laws of the State of Minnesota, without regard to rules pertaining to conflicts of law. The state courts located in Dakota County, Minnesota shall have exclusive jurisdiction.

# **KLUTCH™**

Distributed by:

Northern Tool & Equipment Company, Inc.

Burnsville, Minnesota 55306

[www.northerntool.com](http://www.northerntool.com)

Made in China