

PORTABLE HYDRAULIC DRUM DUMPER - HDD-60-15-P-DC

APPROX WEIGHT: 889.04 lbs.
DOES NOT INCLUDE WEIGHT OF POWER OR PACKAGING!!!

*** ANY ADDITIONS, DELETIONS, OR OMISSIONS MUST BE CORRECTED ON THIS DRAWING AS THIS DRAWING WILL BE CONSIDERED ALL INCLUSIVE ***

ALL GRAPHICS PROVIDED ARE FOR REFERENCE ONLY. IF CERTAIN DIMENSIONS ARE CRITICAL PLEASE VERIFY THOSE DIMENSIONS WITH YOUR SALESPERSON

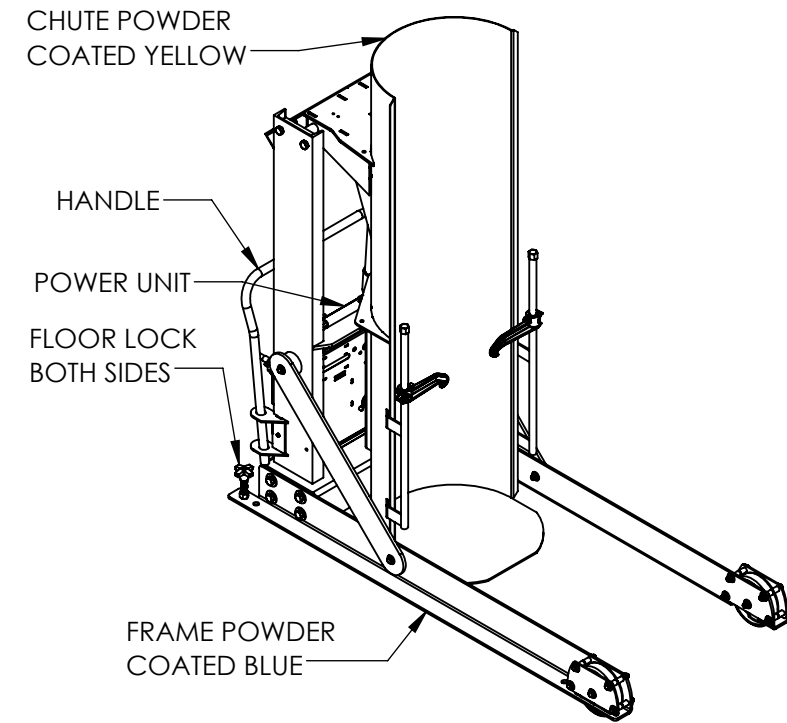
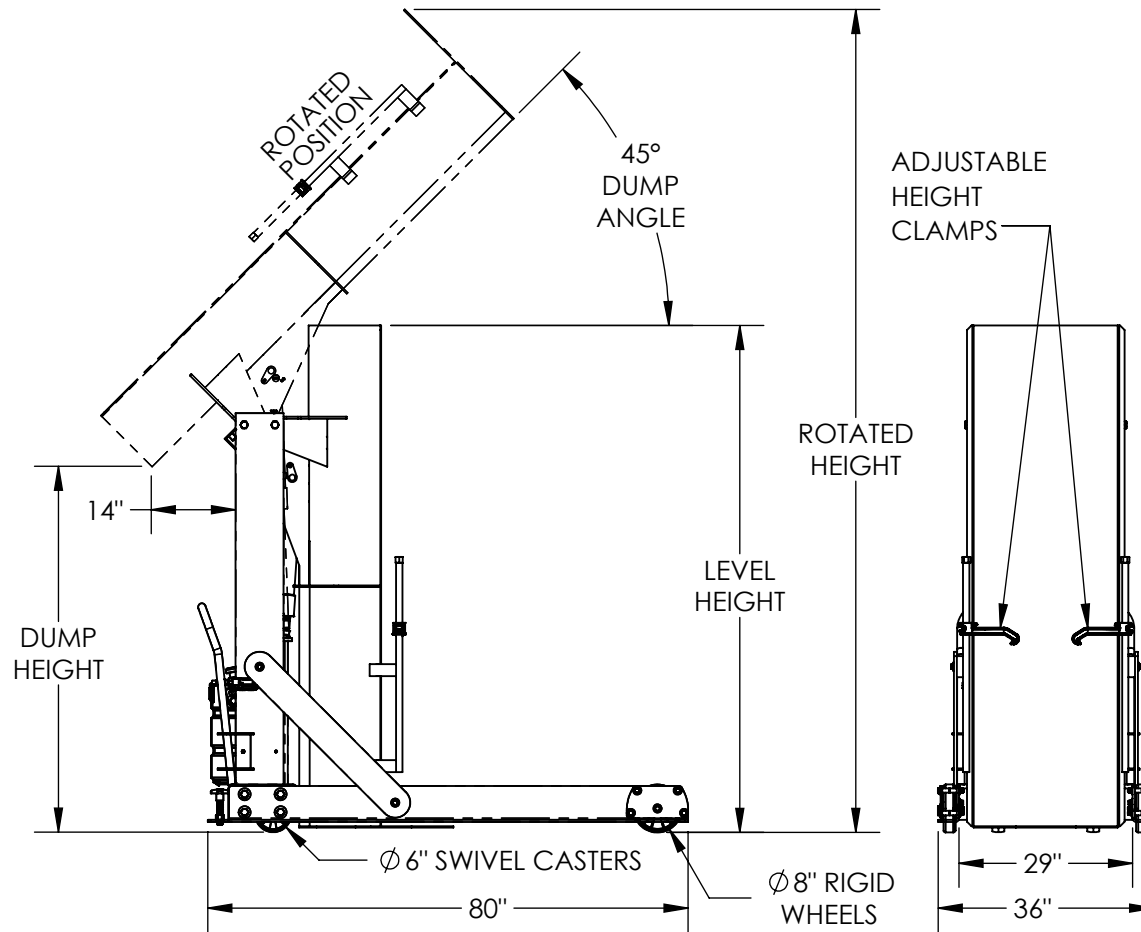

DIMENSION TOLERANCE $\pm 1/4"$

STANDARD FEATURES

- MODEL NUMBER IS HDD-60-15-P-DC
- DUMP HEIGHT IS 60"
- MAX CAPACITY IS 1,500 LBS
- OVERALL WIDTH IS 36"
- OVERALL LENGTH IS 80"
- LEVEL HEIGHT IS 84 1/2"
- ROTATED HEIGHT IS 136 3/4"
- DUMP ANGLE IS 45°
- ACCEPTS DRUM SIZE: Ø16 1/2" TO Ø23 1/2" (ROUND) X 27 1/2" TO 39 1/2" TALL
- ALL STEEL CONSTRUCTION
- DURABLE BAKED IN POWDER COATED FINISH (BASE BLUE & CHUTE YELLOW)
- 2-FUNCTION HANDHELD CONTROL WITH 18"-90" COIL CORD
- WARNING: CHECK STATE AND LOCAL CODES!!!

12 VOLT DC POWER

ON-BOARD BATTERY INDICATOR & CHARGER
CONTACT FACTORY FOR
OTHER POWER OPTIONS

SPECIAL FEATURES

NONE

APPROVAL

I, THE UNDERSIGNED, AGREE THAT THE PRODUCT AS REPRESENTED SATISFIES DESIGN AND DIMENSION REQUIREMENTS. I ALSO ACKNOWLEDGE MY DUTY TO CONFIRM PRODUCT AND INSTALLATION COMPLIANCE WITH ALL APPLICABLE FEDERAL, STATE AND LOCAL REGULATIONS AND STANDARDS.

UNITS REQUIRING APPROVAL DRAWINGS OR MODIFIED ARE NON-RETURNABLE

[] As drawn [] As marked

Signed: _____ Date: _____

Printed Name: _____

LEAD TIME WILL START UPON RECEIPT OF SIGNED APPROVAL DRAWING

DISTRIBUTOR'S NAME:		P.O.#
VESTIL MANUFACTURING		X
DRAWN BY: CRM		DATE: 01/18/2017
REFERENCE: X		SALES: X
QUOTED LEAD TIME: X		SCALE: 1:32
QUOTE # X		FILE NAME: 09-007-128-102