



Operating Instructions and Parts Manual

10 x 14 Horizontal Mitering Band Saw

Model MBS-1014W



JET
427 New Sanford Road
LaVergne, Tennessee 37086
Ph.: 800-274-6848
www.jettools.com

Part No. M-414477
Revision H1 01/2017
Copyright © 2017 JET

1.0 Warranty and Service

JET warrants every product it sells against manufacturers' defects. If one of our tools needs service or repair, please contact Technical Service by calling 1-800-274-6846, 8AM to 5PM CST, Monday through Friday.

Warranty Period

The general warranty lasts for the time period specified in the literature included with your product or on the official JET branded website.

- JET products carry a limited warranty which varies in duration based upon the product. (See chart below)
- Accessories carry a limited warranty of one year from the date of receipt.
- Consumable items are defined as expendable parts or accessories expected to become inoperable within a reasonable amount of use and are covered by a 90 day limited warranty against manufacturer's defects.

Who is Covered

This warranty covers only the initial purchaser of the product from the date of delivery.

What is Covered

This warranty covers any defects in workmanship or materials subject to the limitations stated below. This warranty does not cover failures due directly or indirectly to misuse, abuse, negligence or accidents, normal wear-and-tear, improper repair, alterations or lack of maintenance. JET woodworking machinery is designed to be used with Wood. Use of these machines in the processing of metal, plastics, or other materials outside recommended guidelines may void the warranty. The exceptions are acrylics and other natural items that are made specifically for wood turning.

Warranty Limitations

Woodworking products with a Five Year Warranty that are used for commercial or industrial purposes default to a Two Year Warranty. Please contact Technical Service at 1-800-274-6846 for further clarification.

How to Get Technical Support

Please contact Technical Service by calling 1-800-274-6846. **Please note that you will be asked to provide proof of initial purchase when calling.** If a product requires further inspection, the Technical Service representative will explain and assist with any additional action needed. JET has Authorized Service Centers located throughout the United States. For the name of an Authorized Service Center in your area call 1-800-274-6846 or use the Service Center Locator on the JET website.

More Information

JET is constantly adding new products. For complete, up-to-date product information, check with your local distributor or visit the JET website.

How State Law Applies

This warranty gives you specific legal rights, subject to applicable state law.

Limitations on This Warranty

JET LIMITS ALL IMPLIED WARRANTIES TO THE PERIOD OF THE LIMITED WARRANTY FOR EACH PRODUCT. EXCEPT AS STATED HEREIN, ANY IMPLIED WARRANTIES OF MERCHANTABILITY AND FITNESS FOR A PARTICULAR PURPOSE ARE EXCLUDED. SOME STATES DO NOT ALLOW LIMITATIONS ON HOW LONG AN IMPLIED WARRANTY LASTS, SO THE ABOVE LIMITATION MAY NOT APPLY TO YOU. JET SHALL IN NO EVENT BE LIABLE FOR DEATH, INJURIES TO PERSONS OR PROPERTY, OR FOR INCIDENTAL, CONTINGENT, SPECIAL, OR CONSEQUENTIAL DAMAGES ARISING FROM THE USE OF OUR PRODUCTS. SOME STATES DO NOT ALLOW THE EXCLUSION OR LIMITATION OF INCIDENTAL OR CONSEQUENTIAL DAMAGES, SO THE ABOVE LIMITATION OR EXCLUSION MAY NOT APPLY TO YOU.

JET sells through distributors only. The specifications listed in JET printed materials and on official JET website are given as general information and are not binding. JET reserves the right to effect at any time, without prior notice, those alterations to parts, fittings, and accessory equipment which they may deem necessary for any reason whatsoever. JET® branded products are not sold in Canada by JPW Industries, Inc.

Product Listing with Warranty Period

90 Days – Parts; Consumable items
1 Year – Motors; Machine Accessories
2 Year – Metalworking Machinery; Electric Hoists, Electric Hoist Accessories; Woodworking Machinery used for industrial or commercial purposes
5 Year – Woodworking Machinery
Limited Lifetime – JET Parallel clamps; VOLT Series Electric Hoists; Manual Hoists; Manual Hoist Accessories; Shop Tools; Warehouse & Dock products; Hand Tools; Air Tools

NOTE: JET is a division of JPW Industries, Inc. References in this document to JET also apply to JPW Industries, Inc., or any of its successors in interest to the JET brand.

2.0 Table of contents

Section	Page
1.0 Warranty and Service.....	2
2.0 Table of contents.....	3
3.0 Warnings.....	4
4.0 About this manual.....	5
5.0 Specifications.....	5
6.0 Uncrating and Cleanup.....	6
7.0 Installation.....	6
8.0 Assembly.....	6
9.0 Electrical Connections.....	7
10.0 Controls.....	7
11.0 Prior to Operation.....	7
12.0 Adjustments.....	8
12.1 Adjusting vise square to blade.....	8
12.2 Changing blade speeds.....	8
12.3 Adjusting feed rate.....	8
12.4 Changing blades.....	8
12.5 Blade tracking adjustment.....	9
12.6 Automatic shut-off adjustment.....	10
12.7 Thrust roller adjustment.....	10
12.8 Guide roller adjustment.....	10
12.9 Bow weight adjustment.....	10
12.10 Angle adjustment.....	11
12.11 Vise adjustment.....	11
13.0 Maintenance.....	12
13.1 Lubrication.....	12
14.0 Replacement Parts.....	12
14.1.1 MBS-1014W – Base and Bed Assembly – Exploded View.....	13
14.1.2 MBS-1014W – Bow Assembly – Exploded View.....	14
14.1.3 Parts List for MBS-1014W Band Saw.....	15
14.2.1 MBS-1014W – Gear Speed Reducer Assembly – Exploded View.....	20
14.2.2 MBS-1014W – Gear Speed Reducer Assembly – Parts List.....	21
15.0 Electrical Connections.....	22
15.1.1 Electrical Connections – 1 Phase.....	22
15.1.2 Electrical Panel Layout – 1 Phase.....	22
15.2.1 Electrical Connections – 3 Phase.....	23
15.2.2 Electrical Panel Layout – 3 Phase.....	23



3.0 Warnings

1. **Read and understand the entire instruction manual before attempting assembly or operation.**
2. **All JET bandsaws are designed and intended for use by properly trained and experienced personnel only. If you are not familiar with the proper and safe operation of a bandsaw, do not use until proper training and knowledge have been obtained**
3. Always wear approved safety glasses/face shields while using this machine. (Everyday eyeglasses only have impact resistant lenses; they are not safety glasses.)
4. Make certain the machine is properly grounded.
5. Before operating this machine, remove tie, rings, watches and other jewelry, and roll up sleeves past the elbows. Remove all loose clothing and confine long hair. Do NOT wear gloves.
6. Keep the floor around the machine clean and free of scrap material, oil and grease.
7. Keep machine guards in place at all times when the machine is in use. If removed for maintenance purposes, use extreme caution and replace the guards immediately after completion of maintenance.
8. Do NOT over reach. Maintain a balanced stance at all times so that you do not fall or lean against blades or other moving parts.
9. Make all machine adjustments or maintenance with the machine unplugged from the power source.
10. Use the right tool. Do not force a tool or attachment to do a job for which it was not designed. The right tool will do the job better and more safely.
11. Replace warning labels if they become obscured or removed.
12. Make certain the switch is in the OFF position before connecting the machine to the power supply.
13. Give your work undivided attention. Looking around, carrying on a conversation and “horse-play” are careless acts that can result in serious injury.
14. Keep visitors a safe distance from the work area.
15. Use recommended accessories; improper accessories may be hazardous.
16. Form a habit of checking to see that keys and adjusting wrenches are removed from the machine before turning it on.
17. Always keep hands and fingers away from the blade when the machine is running.
18. Never hand-hold the material. Always use the vise and clamp it securely.
19. Keep belt guard, blade guards, and wheel covers in place and in working order.
20. Always provide adequate support for long and heavy material.
21. Use a sharp blade and keep machine clean for best and safest performance.
22. Failure to comply with all of these warnings may cause serious injury.
23. **CALIFORNIA PROPOSITION 65 WARNING:** This product contains chemicals known to the State of California to cause cancer, or birth defects or other reproductive harm.
24. This product, when used for welding, cutting, or working with metal, produces fumes, gases, or dusts which contain chemicals known to the State of California to cause birth defects and, in some cases, cancer. (California Health and Safety Code Section 25249.5 et seq.)

Familiarize yourself with the following safety notices used in this manual:

CAUTION This means that if precautions are not heeded, it may result in minor injury and/or possible machine damage.

WARNING This means that if precautions are not heeded, it may result in serious, or even fatal, injury.

4.0 About this manual

This manual is provided by JET covering the safe operation and maintenance procedures for a JET Model MBS-1014W Horizontal Saw. This manual contains instructions on installation, safety precautions, general operating procedures, maintenance instructions and parts breakdown. Your machine has been designed and constructed to provide consistent, long-term operation if used in accordance with the instructions as set forth in this document.

If there are questions or comments, please contact your local supplier or JET. JET can also be reached at our web site: www.jettools.com.

Retain this manual for future reference. If the machine transfers ownership, the manual should accompany it.

⚠ WARNING Read and understand the entire contents of this manual before attempting assembly or operation! Failure to comply may cause serious injury!

5.0 Specifications

Model number	MBS-1014W-1	MBS-1014W-3
Stock Number	414479	414477
Capacity:		
Round at 90° (in.)	10	10
Round at 45° (in.)	9	9
Rectangle at 90° (in.)	10 x 14	10 x 14
Rectangle at 45° (in.)	9 x 8-1/2	9 x 8-1/2
Blade Provided (in.)	1 x 0.035 x 130, 4/6VT	1 x 0.035 x 130, 4/6VT
Blade Wheel Diameter (in.)	14	14
Blade Speeds (SFPM)	82, 132, 210, 330	82, 132, 210, 330
Motor	2HP, 1PH, 230V only	3HP, 3PH, 230/460V (Prewired 230V)
Throat Depth (in.)	10-1/2	10-1/2
Head Swivels	45°	45°
Lowered Height (in.)	43	43
Raised Height (in.)	73	73
Bed Height (in.)	25	25
Floor Space Required (in.)	26 x 69	26 x 69
Net Weight (lb)	948	948
Shipping Weight (lb)	1102	1102

The specifications in this manual were current at time of publication, but because of our policy of continuous improvement, JET reserves the right to change specifications at any time and without prior notice, without incurring obligations.

6.0 Uncrating and Cleanup

NOTE: Read and understand the entire manual before attempting setup or operation.

1. Finish uncrating the saw and inspect for damage. Should any have occurred, contact your local distributor.
2. Remove all bolts attaching machine to shipping base.
3. Leave packing material between vice clamps and saw head intact until bandsaw has been lifted to its final position.
4. Clean all rust protected surfaces with kerosene or diesel oil to remove protective coating. Do not use gasoline, paint thinner, mineral spirits, etc. These may damage painted surfaces.
5. Lubricate all slideways with SAE 10W oil.

7.0 Installation

For best performance, the bandsaw should be located on a solid and level foundation. Allow room for servicing and for moving large stock around the bandsaw when deciding a location for the machine.

1. Using lifting straps that are isolated from the bandsaw's finished surfaces, place machine in desired location. See Figure 1 for strap placement.

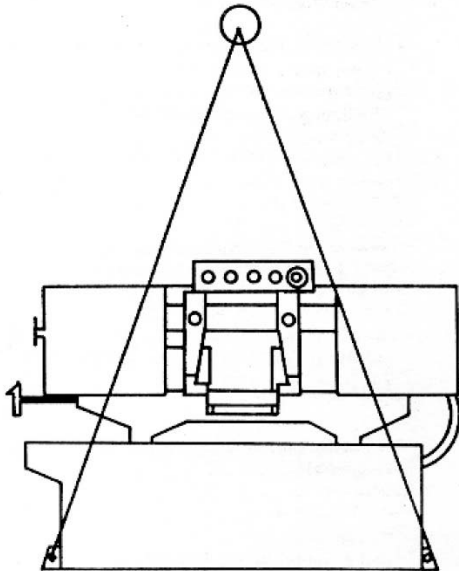

Figure 1

2. Install four leveling bolts with lock nuts on both sides of the base as shown in the parts breakdown in sect. 14.1.1, items #2 and #3.
3. Place a level on the table surface and check side to side and front to back.
4. Adjust leveling screws until machine is level in both directions and tighten locking nuts.

8.0 Assembly

1. Unbolt the motor assembly from the shipping crate bottom.
2. Remove nut (A, Figure 2) and washer (B, Figure 2) from the motor support shaft. Note: Picture shows motor already in place.

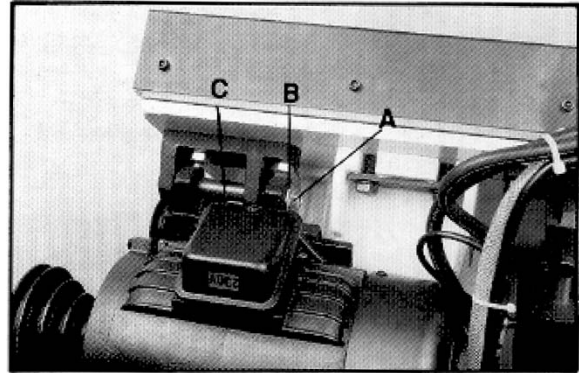

Figure 2

3. Remove shaft (C, Figure 2) from the motor mount bracket.
4. Carefully lift motor and line up holes in the motor mounting place and the motor bracket.
5. Slide motor support shaft into motor mount bracket to hold the motor in place.
6. Fasten shaft with nut and washer.
7. Loosen strain relief nut on the motor junction box. Remove the junction box cover. Insert wire through strain relief and wire to the terminal strip using the diagram on the junction box cover. Tighten the strain relief nut and replace the junction box cover.
8. Remove two hex cap bolts and washers (A, Figure 3) from the right side of the saw arm.

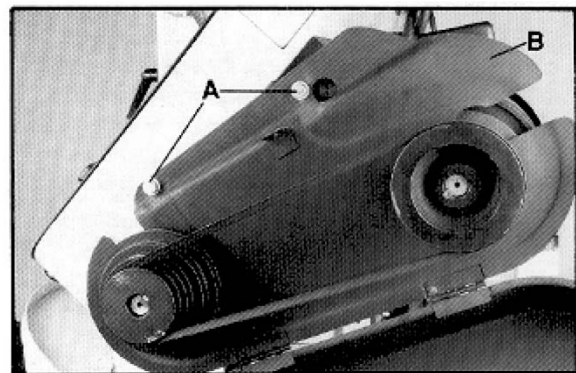

Figure 3

9. Slide belt cover (B, Figure 3) around pulley shafts and attach to saw with two hex cap bolts and two washers.
10. Lift motor and place v-belt around both pulleys. Lower motor.

11. Tension the v-belt by pushing down on the motor and tightening the lock handle on the motor tilt plate. Correct tension is achieved when finger pressure between the two pulleys causes approximately a 1/2" deflection.
12. Close pulley cover door and fasten with lock knob.
13. Fasten work stop rod (#241, sect. 14.1.1) to saw bed (#11A) by inserting into bed and turning clockwise until tight. Place work stop bracket (#16) onto stop rod (#241) and tighten lock handle (#20). Attach stop screw (#19) to stop bracket (#16) with lock handle (#18) and tighten.

9.0 Electrical Connections

⚠WARNING All electrical connections must be done by a qualified electrician. Failure to comply may result in serious injury.

⚠WARNING Disconnect machine from the power source before changing any voltage components. Failure to comply may cause serious injury.

The MBS-1014W bandsaw is rated at 3HP, 3 phase 230/460V, prewired 230V; or 2HP, single phase, 230V only. Confirm power available at the saw's location is the same as the saw is wired. To switch the MBS-1014W from 230V to 460V, the following items will have to be changed:

- **Main Motor** – follow diagram inside junction box cover.
- **Coolant Pump** – Remove access panel on right side of saw, remove junction box cover on pump, and follow diagram inside junction box cover. See Figure 4.

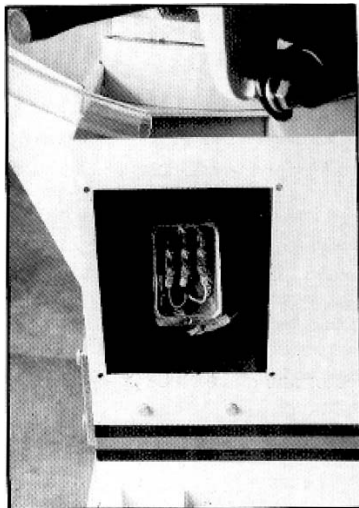

Figure 4

- **Control Transformer** – Open electrical panel on rear of base and switch primary wire on transformer from 230V to 460V.

Machine must always be correctly grounded.

Note: the power cord end will have to be changed to one that is rated 460V when changing voltage.

10.0 Controls

See Figure 5.

Power Indicator Light (A) – lit whenever machine is running.

Start Button (B) – depress to start bandsaw.

Emergency Stop Button (C) – depress to immediately stop all machine functions.

Coolant Switch (D) – turn arrow to "I" to turn on flow of coolant. Turn arrow to "O" to stop flow of coolant.

Cutting Pressure Control (E) – turn clockwise to decrease cutting pressure. Turn counterclockwise to increase cutting pressure.

Hydraulic On-Off Valve (F) – turns hydraulic cylinder on and off.

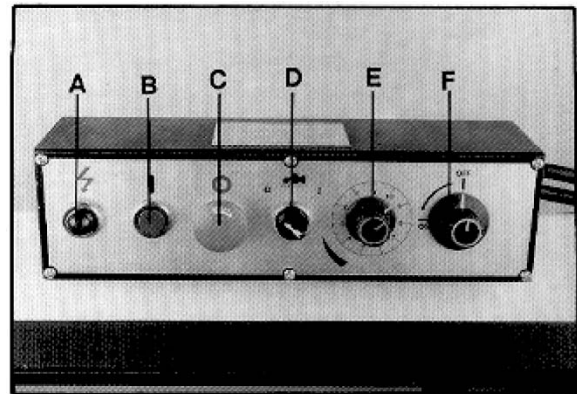

Figure 5

11.0 Prior to Operation

1. Check that blade tooth direction matches diagram on blade guides.
2. Check to see that blade is properly seated on wheels after applying correction tension (approximately 25,000 lbs.)
3. Set blade holder guides for approximately 0.003" to 0.005" clearance between the guides and blade.
4. Check for slight clearance between back-up rollers and back of blade.
5. Position blade guides as close to work piece as possible.

6. Select proper speed and feed rate for material being cut. Consult Machinery's Handbook or similar source for speed and feed charts.
7. Material to be cut must be securely held in vise.
8. Check to see that coolant level is adequate and turn on coolant pump if material to be cut requires it. Machine should be filled with four gallons of the proper coolant mixture. Follow the directions on the product maker's label and fill the coolant tank through the chip tray area.
9. Do not start cut on a sharp edge.
10. Keep machine lubricated. See "Lubrication" section.

12.0 Adjustments

12.1 Adjusting vise square to blade

1. Disconnect machine from power source.
2. Place a machinist's square on the table against the blade and the vise. The square should lie along the entire length of the vise and blade without a gap.
3. If adjustment is necessary, loosen bolts holding the vise and adjust vise so square lines up properly. Tighten bolts.
4. Connect machine to the power source.

12.2 Changing blade speeds

⚠WARNING Disconnect the machine from the power source before making any repair or adjustment. Failure to comply may cause serious injury.

1. Disconnect machine from power source.
2. Open pulley cover by supporting the belt cover with one hand while removing the belt cover lock knob with the other. Lower guard gently to its full open position.
3. Support motor with one hand while loosening lock handle. Lower motor gently.
4. Position belt in grooves according to the speed selection chart.
5. Tension the v-belt by pushing down on the motor and tightening the lock handle on the motor tilt plate. Correct tension is achieved when finger pressure on the belt between the two pulleys causes approximately 1/2" deflection.
6. Close pulley cover and fasten.
7. Connect machine to the power source.

12.3 Adjusting feed rate

Rate of feed is adjusted by turning the cutting pressure control knob on the control panel. Rate of feed is important to bandsaw performance, excessive pressure may break the blade or stall the saw. Insufficient pressure rapidly dulls the blade.

Material chips or shavings are the best indicator of proper speed and pressure. The ideal chip is thin, tightly curled, and warm to the touch. Chips that range from golden brown to black indicate excessive force. Blue chips indicate extreme heat from too high a band speed which will shorten blade life. Thin or powdered chips indicate insufficient feed pressure.

12.4 Changing blades

⚠WARNING Disconnect the machine from the power source before making any repair or adjustment (with the exception of blade tracking). Failure to comply may cause serious injury.

1. Disconnect machine from power source.
2. Raise saw arm approximately 6". Hold saw arm in place by closing cutting pressure control valve.
3. Open both wheel covers and clean chips out of both wheel housings. Loosen two lock knobs below the control panel and remove upper blade guard.
4. Loosen set screw (A, Figure 6) and lower the blade cleaning brush.

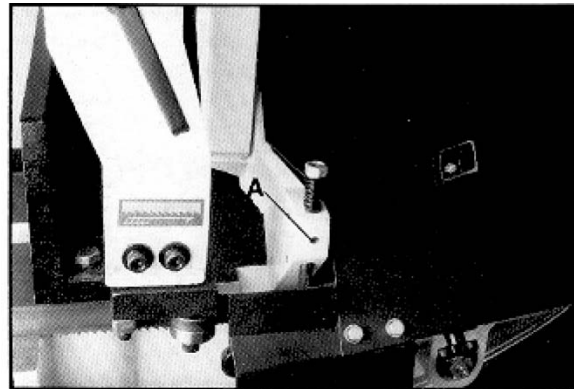

Figure 6

5. Release blade tension by turning blade tensioning handwheel (A, Figure 7) counterclockwise until blade is free.

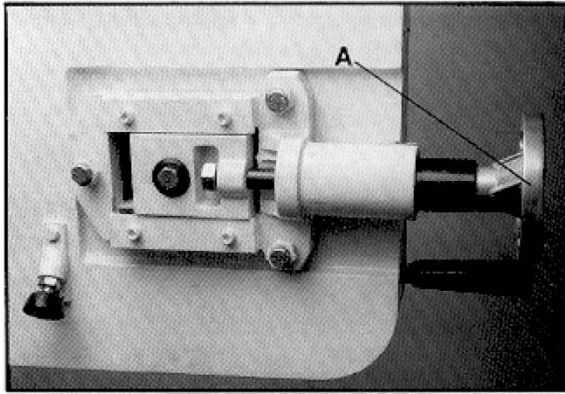

Figure 7

- Loosen lock knob (A, Figure 8) and slide left blade guide arm (B, Figure 8) to the right as far as possible.

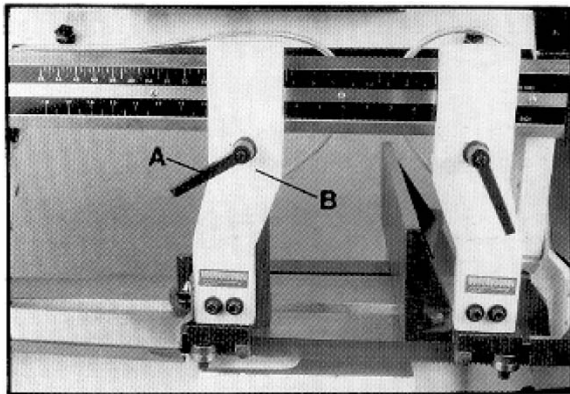

Figure 8

- Remove old blade from both wheels and out of each blade guide.

CAUTION Even dull blades are sharp to the skin. Use extra caution handling bandsaw blades.

- Install new blade making sure teeth are pointed downward in the proper cutting direction. If necessary, turn blade inside out.
- Position blade on band wheels and tighten just enough to hold blade on wheels. Make sure back of blade rests lightly against the wheel flange of both wheels. Twist blade slightly to allow it to slip into guides.
- Tension blade to approximately 25,000 lbs., as indicated on the blade tension indicator found on the tension wheel shaft housing.
- Raise wire brush and tighten set screw to hold brush in place.
- Close all covers and guards and fasten securely. Connect machine to power and run freely for approximately two minutes.

- Turn power off and recheck blade tension and wire brush adjustment. If further adjustment is necessary, disconnect saw from power source, make adjustments, and reconnect to power.

12.5 Blade tracking adjustment

Blade tracking has been set at the factory and should require no adjustment. If a tracking problem occurs, adjust the machine as follows:

WARNING Tracking adjustment is done with the wheel covers open to observe the blade. Use extreme caution so as not to come into contact with the blade.

Since tracking can only be adjusted while machine is running, it is suggested that this adjustment be accomplished by qualified personnel that are familiar with this type of adjustment and the dangers associated with it.

- Disconnect machine from power source.
- Raise saw arm to its highest position and close cutting pressure control valve to hold saw arm in place.
- Locate tracking adjustment plate on the back side of the driven blade wheel.
- Loosen the three bolts (A, Figure 9) located on the top of the tracking nuts.
- Tracking adjustment is accomplished by either loosening or tightening three adjusting nuts (B, Figure 9).
- Tracking is set properly when the back of the blade lightly touches the wheel flange. **Note:** Over-tracking (allowing blade back to rub hard against wheel flange) will damage the blade wheels and blade.
- Tighten locking bolts (A, Figure 9) once proper tracking is completed.
- Connect machine to the power source.

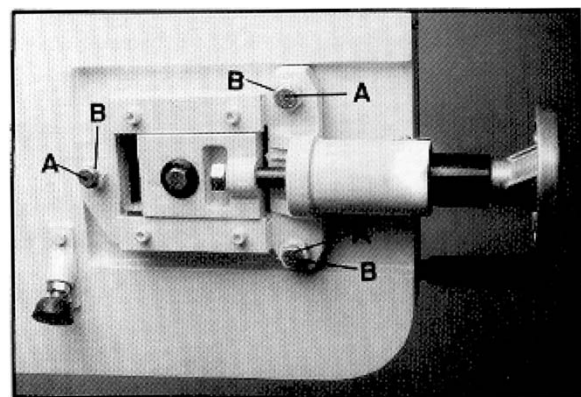

Figure 9

12.6 Automatic shut-off adjustment

The motor should shut off immediately after the blade has cut through the material and just before the head comes to rest on the horizontal stop bolt. If the machine continues to run after the work piece has been fully cut, locate and adjust the micro switch mounting plate down. If the machine shuts off before the work piece has been completely cut, move the micro switch mounting plate up.

12.7 Thrust roller adjustment

1. Disconnect machine from power source.
2. Loosen two hex socket cap screws (A, Figure 10).
3. Move guide seat (B, Figure 10) up or down until a clearance of 0.003" to 0.005" between back of blade and thrust roller is obtained.
4. Tighten two hex socket cap screws (A, Figure 10).
5. Repeat for other blade guide assembly.
6. Connect machine to power source.

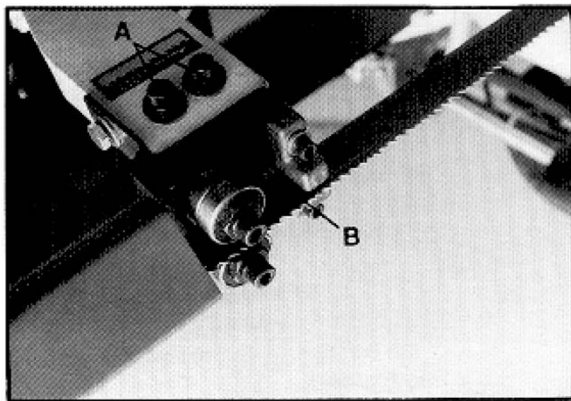

Figure 10

12.8 Guide roller adjustment

1. Disconnect machine from power source.
2. Loosen blade guides (A, Figure 11) by loosening screws (B, Figure 10). Slide blade guides away from blade.
3. Loosen locking screws (C, Figure 11) by using a hex wrench.
4. Adjust the eccentric bushings with a combination wrench until the ball bearings are snug to the blade. Note: Blade should travel freely up and down between the ball bearings. Do not pinch the blade.
5. Tighten locking screws (C, Figure 11).
6. Slide blade guides back into contact with blade and tighten screws (B, Figure 11).
7. Connect machine to the power source.

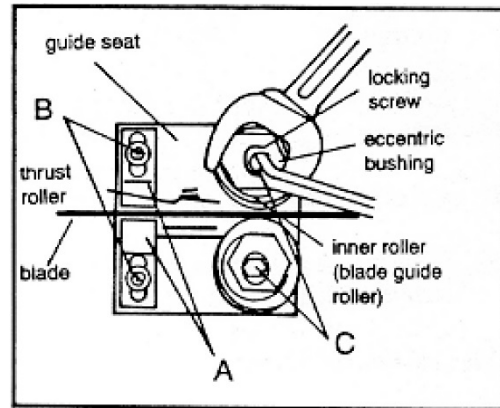

Figure 11

12.9 Bow weight adjustment

Bow weight is one of the most important adjustments of the saw. If the bow weight is not set properly, one can expect poor performance, crooked cuts, tooth stripping, stalling, and the blade popping off the blade wheels. The hydraulic feed rate unit will not compensate for improper bow weight. Bow weight has been set at the factory and should not need any adjustment. If adjustment is necessary:

1. Disconnect machine from power source.
2. Turn on hydraulic valve (F, Figure 5).
3. Turn cutting pressure control valve (E, Figure 5) counterclockwise until it stops.
4. Place one end of a fish-type scale under the blade tension handle and lift the saw with the other end. Scale should indicate approximately 22-24 lbs.
5. Adjust tension to approximately 22-24 lbs. by turning the adjustable C-bolt found at the end of the coil spring on the rear of the bandsaw. See Figure 12.
6. Connect the machine to the power source.

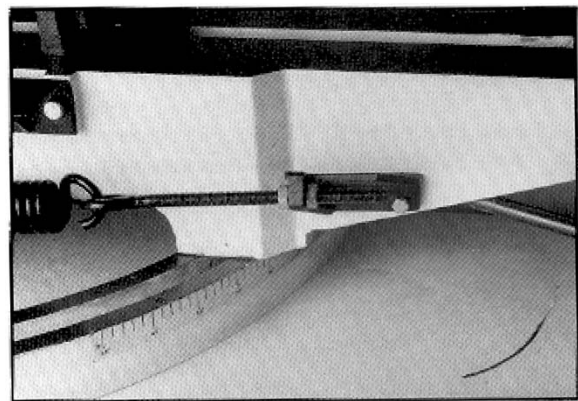

Figure 12

12.10 Angle adjustment

To swivel the saw arm up to a 45° angle:

1. Disconnect machine from power source.
2. Pull the handle (A, Figure 13) toward the front of the saw.
3. Rotate the upper assembly to the desired angle.
4. Push the handle back toward the rear of the saw to lock the upper assembly.

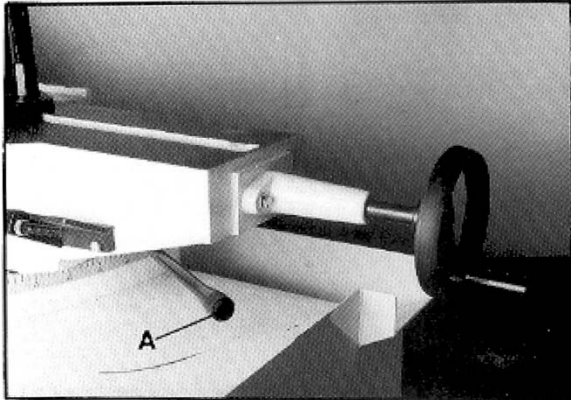

Figure 13

To adjust the 90° stop:

1. Disconnect machine from power source.
2. Lower saw arm completely.
3. Pull the lock lever toward the front of the saw and pull the saw arm assembly against the 90° stop.
4. Place a 90° square on the blade and the fixed vise jaw.
5. Loosen the lock nut (A, Figure 14).
6. Adjust the hex cap screw (B, Figure 14) until the blade is at a 90° angle to the fixed vise jaw.
7. Tighten the lock nut (A, Figure 14).

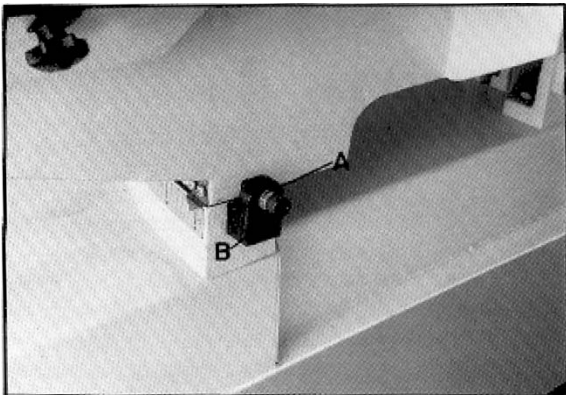

Figure 14

To adjust the 45° stop:

1. Disconnect machine from power source.
2. Lower saw arm completely.
3. Pull the lock lever toward the front of the saw and push the saw arm assembly against the 45° stop.
4. Place a 45° angle square on the blade and the fixed vise jaw.
5. Loosen the lock nut (A, Figure 15).
6. Adjust the hex cap screw (B, Figure 15) until the blade is at a 90° angle to the fixed vise jaw.
7. Tighten the lock nut (A, Figure 15).

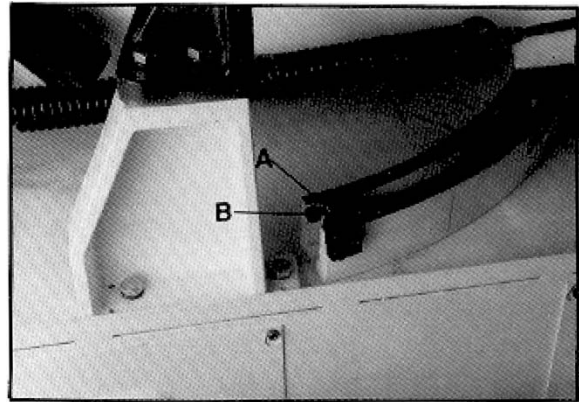

Figure 15

12.11 Vise adjustment

To position the movable vise jaw:

1. Turn vise handwheel 1/2 turn counter clockwise.
2. Move rack block (B, Figure 16) to desired location by sliding along the bed. Place the rack block onto the rack.
3. Turn the handwheel to tighten the vise.

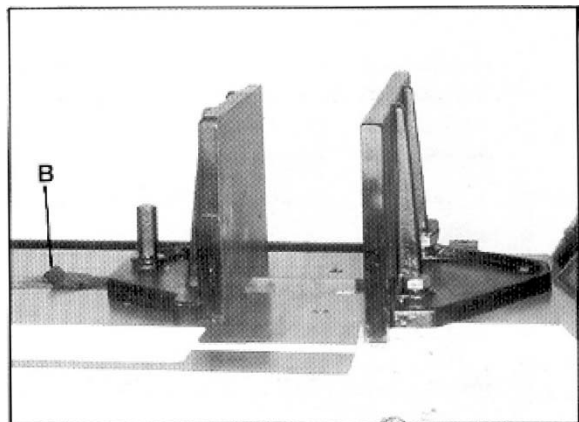

Figure 16

To adjust the vise for angle cutting:

1. Loosen adjustable handle (index #219,221) to desired location.
2. Set the vise to desired angle, reinstall nuts and tighten the nut and bolt assemblies.
3. Adjust the movable vise parallel to the fixed vise by loosening bolt (A, Figure 17), adjusting to parallel, and tightening bolt.

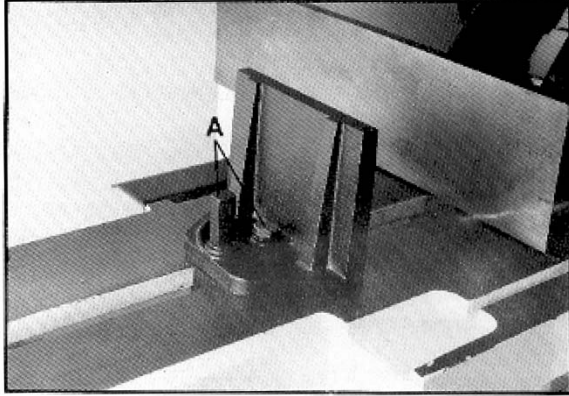

Figure 17

13.0 Maintenance

Keep bandsaw and motor clean.

13.1 Lubrication

All ball bearings are permanently lubricated and sealed. They require no further lubrication.

The gear box lubricant should be changed after the first 50 hours of operation. Change lubricant from then on every 250 hours of operation.

To check level of gear box lubricant, place saw arm in down position and allow a few minutes to pass so that oil drains down. Check level in sight glass on side of gear casing. Correct level is the dot in the middle of sight glass.

To change gear box lubricant:

1. Disconnect machine from power source.
2. Open drain plug and allow lubricant to drain completely. Drain plug may be found on lower rear of gear case. Remove drain plug with a hex wrench.
3. Replace drain plug.
4. Remove filler cap (A, Figure 18) and fill gear box with 50 weight gear oil until level reaches dot in middle of sight glass.
5. Replace filler cap.
6. Connect machine to the power source.

Use a light machine oil to lubricate all other moving parts as needed.

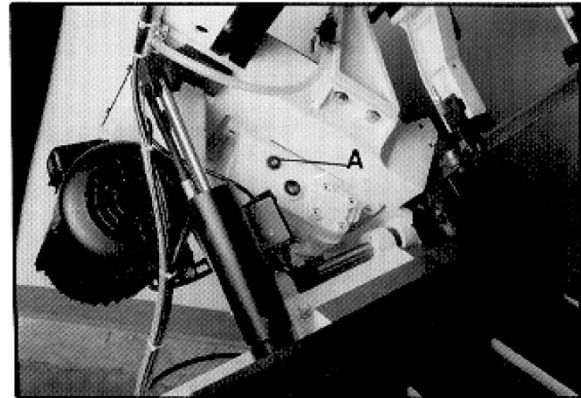
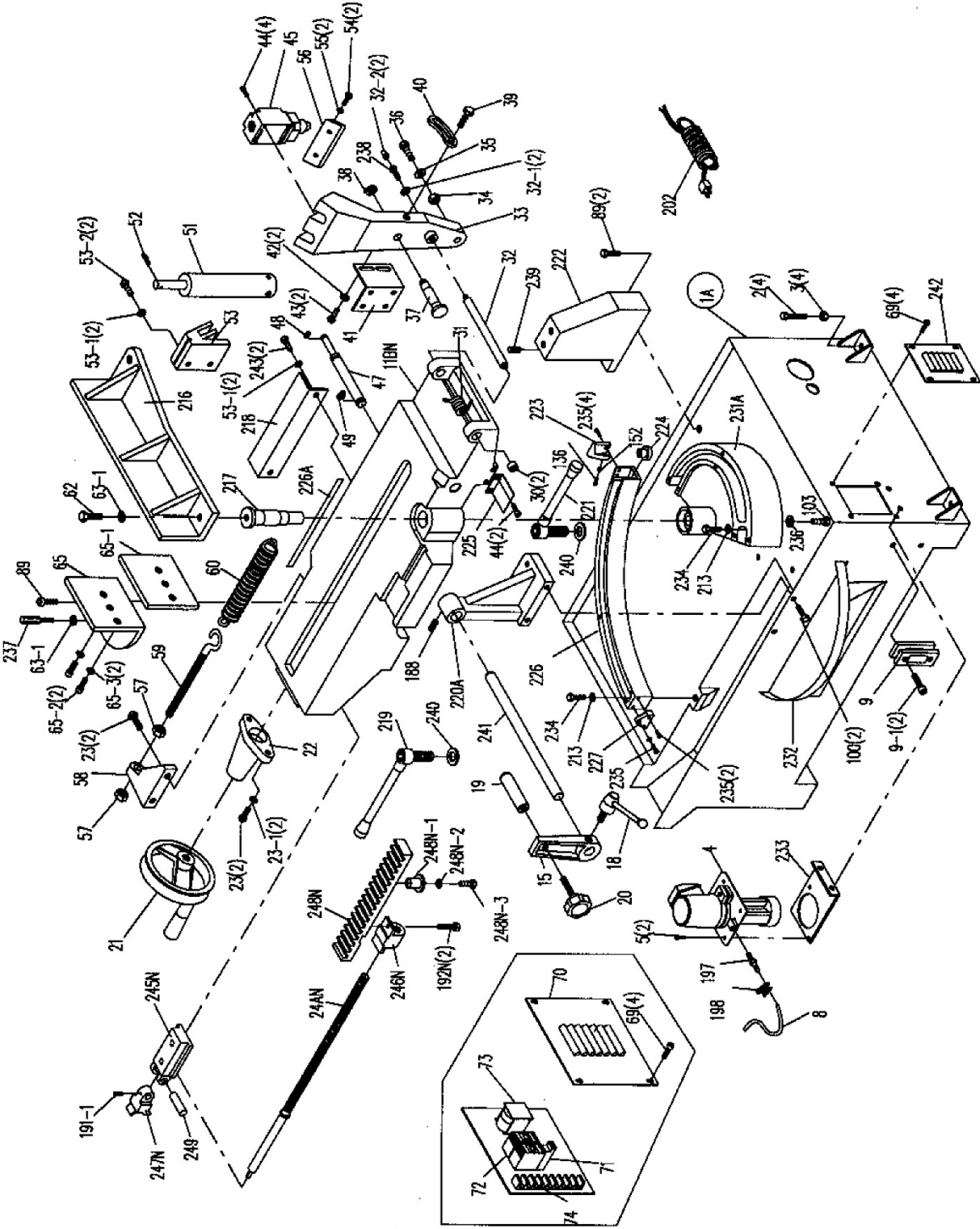

Figure 18

14.0 Replacement Parts

Replacement parts are listed on the following pages. To order parts or reach our service department, call 1-800-274-6848 Monday through Friday, 8:00 a.m. to 5:00 p.m. CST. Having the Model Number and Serial Number of your machine available when you call will allow us to serve you quickly and accurately.

14.1.1 MBS-1014W – Base and Bed Assembly – Exploded View



14.1.2 MBS-1014W – Bow Assembly – Exploded View

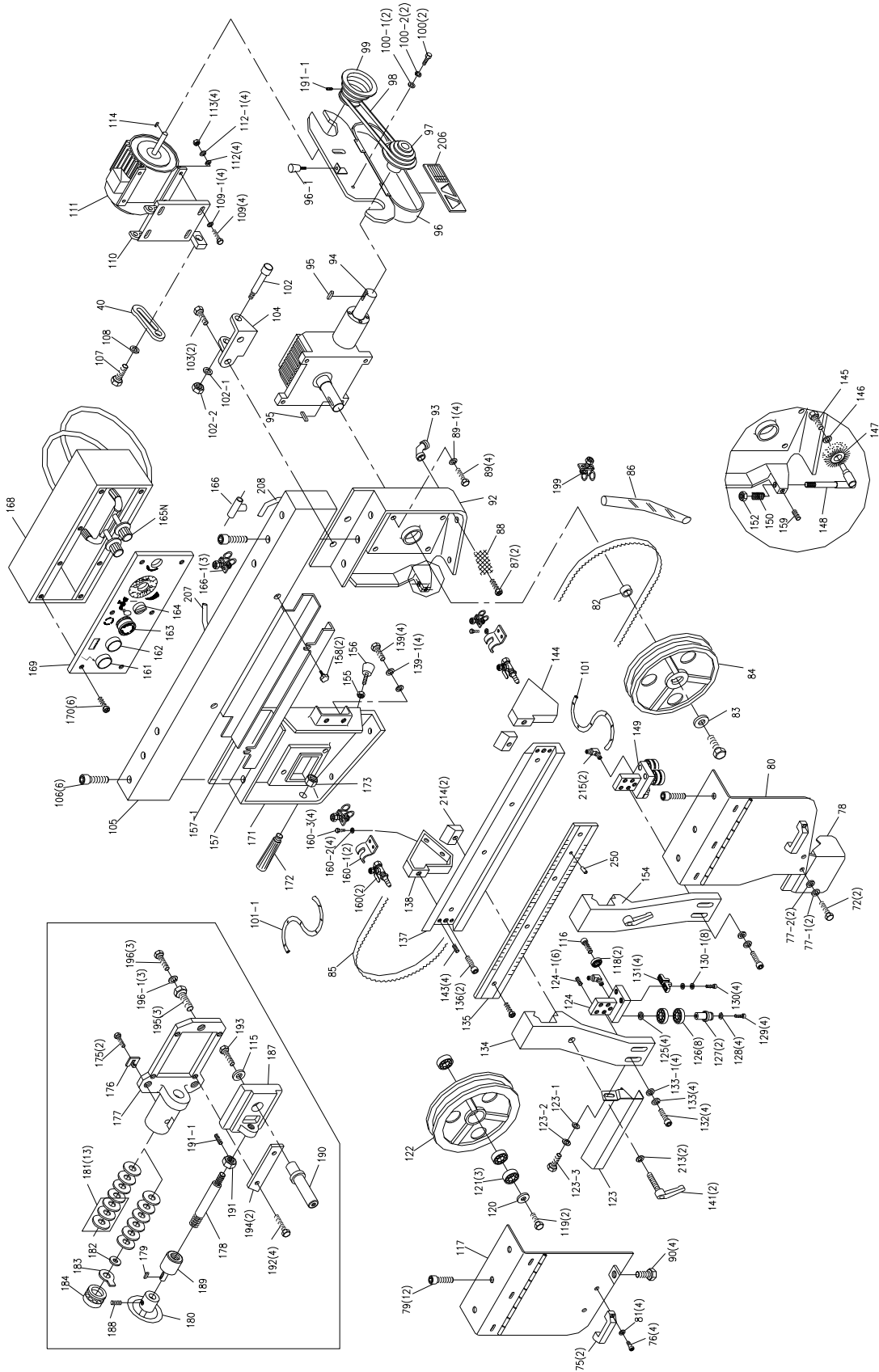

14.1.3 Parts List for MBS-1014W Band Saw

Index No	Part No	Description	Size	Qty
1A	MBS1014W-1AG	Base		1
2	Ts-1492071	Hex Cap Bolt	M12x70	4
3	TS-1540081	Hex Nut	M12	4
4	HBS916W-CP	Coolant Pump (1PH)		1
	MBS1014W-CP	Coolant Pump (3PH)		1
5	TS-15311051	Pan Head Screw	M6x16	2
8	HBS916W-08	Hose		1
9	HBS916W-09	Coolant Gauge		1
9-1	TS-1491041	Hex Cap Bolt	M10x30	2
11A	MBS1014W-11A	Bed		1
11B	MBS1014W-11B	Bed (s/n 01021646 and lower)		1
11BN	MBS1014W-11BNG	Bed (s/n 01021647 and higher)		1
15	HBS916W-16	Stop Bracket		1
18	HBS916W-18	Lock Handle		1
19	HBS916W-19	Work Stop		1
20	HBS916W-20	Lock Knob		1
21	HBS1018W-21	Handwheel Assembly		1
22	HBS1018W-22G	Lead Screw Seat		1
23	TS-1490051	Hex Cap Bolt	M8x30	4
23-1	TS-1551061	Lock Washer	M8	2
24A	MBS1014W-24A	Lead Screw (s/n 01021646 and lower)	780mm	1
24AN	MBS1014W-24AN	Lead Screw (s/n 01021647 and higher)	530mm	1
25	HBS916W-25	Lead Screw Bracket (s/n 903358 and lower)		1
26	HBS916W-26	Acme Nut (Re:HBS916W-26A)(s/n 903358 and lower)		1
	HBS916W-26A	Acme Nut Assembly (inc. 26,27,28,29)(s/n 903358 and lower)		1
27	HBS916W-27	Button (Re:HBS916W-26A)(s/n 903358 and lower)		1
28	HBS916W-28	Retainer (Re:HBS916W-26A)(s/n 903358 and lower)		2
29	HBS916W-29	Pan Head Screw (Re:HBS916W-26A)(s/n 903358 and lower)		1
30	HK-2516-2RS	Needle Bearing		2
31	HBS1018W-31	Torsion Spring		1
32	HBS916W-32	Pivot Shaft		1
32-1	TS-1550041	Washer	M12	2
32-2	HBS916W-32-2	Bolt w/ Zerk Fitting		2
33	HBS1018W-33G	Pivot Bracket		1
34	TS-1540081	Nut	M12	1
35	TS-1550081	Washer	12mm	1
36	TS-1492041	Hex Cap Bolt	M12x40	1
37	HBS916W-37	Torsion Spring Shaft		1
38	HBS916W-38	C-Ring	S-22	1
39	TS-1490041	Hex Cap Bolt	M8x25	1
40	HBS1018W-40	Motor Tilt Plate		1
41	HBS916W-41	Limit Switch Plate		1
42	TS-1550061	Washer	8mm	2
43	TS-1490031	Hex Cap Bolt	M8x20	2
44	TS-1482021	Hex Cap Screw	M6x12	6
45	HBS916W-45	Limit Switch		1
47	HBS1018W-47A	Cylinder Pin		1
48	HBS916W-48	C-Ring	S-20	1
49	HBS916W-49	C-Ring	S-25	2
51	HBS1018W-51	Hydraulic Cylinder Assembly		1
52	HBS916W-52	Cylinder Pin		1
53	HBS1018W-53	Hydraulic Mounting Plate - Top		1
53-1	TS-1551071	Lock Washer	10mm	4
53-2	TS-1491041	Hex Cap Bolt	M10x30	2
54	TS-1492051	Hex Cap Bolt	M12x50	2
55	TS-1550081	Washer	12mm	2
56	HBS916W-56	Plate		1

Index No	Part No	Description	Size	Qty
57	TS-0561051	Hex Nut	1/2"	2
58	HBS916W-58	Spring Bracket		1
59	HBS916W-59	Adjustable C-Bolt		1
60	HBS1018W-60	Spring		1
62	TS-1492041	Hex Cap Bolt	M12x40	2
63-1	TS-1551081	Lock Washer (s/n 0202755 and lower)	12mm	6
	TS-1551081	Lock Washer (s/n 0202756 and higher)	12mm	2
65	HBS916W-64	Vise Jaw – left		1
65-1	MBS1014W-65-1	Extension Plate		1
65-2	MBS1014W-65-2	Hex Socket Cap Screw		2
65-3	MBS1014W-65-3	Lock Washer		2
69	TS-1503011	Hex Socket Cap Bolt	M6x8	8
70	HBS916W-70G	Electrical Panel Cover		1
71	HBS916W-71	Fuse Block		2
72	HBS1018W-72	Magnetic Switch (1PH)		1
	MBS1014W-72	Magnetic Switch (3PH)		1
73	HBS1018W-73	Transformer (1PH)		1
	MBS1014W-73	Transformer (3PH)		1
74	HBS916W-74	Transformer Strip		1
75	HBS916W-75	Handle		1
76	TS-1534051	Pan Head Screw	M6x16	4
77	TS-1482021	Hex Cap Bolt	M6x12	2
77-1	TS-1551041	Lock Washer	M6	2
77-2	TS-1550041	Washer	M6	2
78	HBS916W-78	Wire Brush Guard		1
79	TS-1503011	Hex Socket Cap Screw	M6x8	12
	HBS1018W-79A	Adjustable Bracket Mount - rear (HBS-1018W only; not shown)		1
80	HBS1018W-80AG	Blade Wheel Cover - right		1
81	TS-1550041	Washer	M6	4
82	HBS916W-82	Bushing		1
83	HBS916W-83	Washer		1
84	MBS1018W-84	Drive Wheel		1
85		Blade (local purchase)		1
86	HBS916W-86	Hose		1
87	TS-1533031	Pan Head Screw	M5x10	2
88	HBS916W-88	Filter Screen		1
89	TS-1492031	Hex Cap Bolt	M12x35	5
89-1	TS-1551081	Lock Washer	12mm	4
90	HBS916W-90	Lock Knob		4
92	HBS1018W-92G	Blade Wheel Box - right		1
93	HBS1018W-93	Connector		1
94	HBS1018W-94G	Gear Box Assembly (can only order entire assembly)		1
95	HBS916W-95	Key	7mm	1
96	HBS1018W-96	Pulley Cover		1
96-1	HBS916W-96-1	Lock Knob		1
97	HBS1018W-97	Gear Box Pulley		1
98	VB-A37	V-Belt		1
99	HBS1018W-99	Motor Pulley		1
100	TS-1482031	Hex Cap Bolt	M8x16	4
100-1	TS-1550061	Washer	M8	2
100-2	TS-1551061	Lock Washer	M8	2
101	HBS916W-101	Hose		1
101-1	HBS916W-101-1	Hose		1
102	HBS916W-102	Support Shaft		1
102-1	TS-1550081	Washer	M12	1
102-2	TS-1540081	Hex Nut	M12	1
103	TS-1492021	Hex Cap Bolt (S/N 0202755 and lower)	M12x30	5
	TS-1492021	Hex Cap Bolt (S/N 0202756 and higher)	M12x30	1
104	HBS916W-104	Motor Mount Bracket		1
105	HBS1018W-105AG	Column		1

Index No	Part No	Description	Size	Qty
106	TS-1506011	Hex Socket Cap Screw	M12x20	6
107	HBS916W-107	Locking Handle		1
108	TS-1550061	Washer	8mm	1
109	TS-1490081	Hex Cap Bolt	M8x45	4
109-1	TS-1550061	Washer	M8	4
110	HBS916W-110	Motor Mount Plate		1
111	HBS1018W-111	Motor	2HP, 1PH, 230V only	1
	MBS1014W-111	Motor	3HP, 3PH, 230/460V	1
	HBS1018W-111A	Capacitor (not shown)	400MFD, 125VAC	1
	HBS1018W-111B	Capacitor Cover (not shown)		1
112	TS-1550061	Washer	M8	4
112-1	TS-1551061	Lock Washer	M8	4
113	TS-1540061	Hex Nut	M8	4
114	HBS916W-114	Key	7mm	1
115	TS-1550081	Washer	M12	1
116	TS-1504041	Hex Socket Cap Screw	M8x20	1
117	HBS1018W-117AG	Blade Wheel Cover - left		1
118	BB-608VV	Ball Bearing		2
119	TS-1492011	Hex Cap Bolt	M12x25	2
120	TS-1550081	Washer	M12	1
121	BB-6205Z	Ball Bearing		3
122	MBS1014W-122	Idler Wheel		1
123	HBS1018W-123A	Blade Guard		1
123-1	TS-1550061	Washer	M8	1
123-2	TS-1551061	Lock Washer	M8	1
123-3	TS-1490021	Hex Cap Bolt	M8x16	1
124	HBS916W-124	Guide Bracket - left		1
	HBS916W-124A	Guide Bracket Assembly - left		1
124-1	TS-1504031	Hex Socket Cap Screw	M8x16	6
125	TS-1540061	Washer	M8	4
126	BB-6201VV	Ball Bearing		8
127	HBS916W-127	Eccentric Sleeve (outside)		2
127-1	HBS1018W-127-1	Sleeve (inside, not shown)		2
128	TS-1551061	Lock Washer	M8	4
129	TS-1504091	Hex Socket Cap Screw	M8x45	4
130	TS-1503071	Hex Socket Cap Screw	M6x30	4
130-1	TS-1550041	Washer	M6	8
131	HBS916W-131	Blade Guide		4
132	TS-1504081	Hex Socket Cap Screw	M8x40	4
133	TS-1551081	Lock Washer	M8	4
133-1	TS-1550081	Washer (HBS-916W)	M8	4
134	HBS1018W-134AG	Adjustable Bracket		1
135	HBS1018W-135	Scale		1
136	TS-1505031	Hex Socket Cap Screw	M10x25	2
137	HBS1018W-137G	Slide		1
138	HBS1018W-138G	Blade Bracket - left		1
139	TS-1492021	Hex Cap Bolt	M12x30	4
139-1	TS-1551081	Lock Washer	M12	4
141	MBS1014W-141	Knob		2
143	TS-1524021	Set Screw	M8x10	4
144	HBS1018W-144G	Blade Bracket - right		1
145	TS-1482011	Hex Cap Bolt	M6x10	1
146	TS-1550041	Washer	M6	1
147	HBS916W-147	Wire Brush		1
148	HBS916W-148	Wire Brush Rod		1
149	HBS1018W-149	Guide Bracket - right		1
	HBS1018W-149A	Guide Bracket Assembly - right		1
150	HBS916W-150	Spring		1
152	TS-1540071	Hex Nut	M10	2
154	HBS1018W-154AG	Adjustable Bracket - right		1
155	TS-1540081	Hex Nut	M12	1

Index No	Part No	Description	Size	Qty
156	MBS1014W-156	Hex Cap Bolt with Rubber Stopper	M12x60	1
157	HBS1018W-157AG	Blade Guard		1
157-1	HBS1018W-157-1G	Blade Guard - down		1
158	HBS916W-158	Lock Knob		2
159	TS-1523021	Set Screw	M6x8	1
160	HBS916W-160	Adjusting Valve		2
160-1	HBS916W-160-1	Clamp		2
160-2	TS-1551041	Lock Washer	M6	4
160-3	TS-1482021	Hex Cap Bolt	M6x12	4
161	HBS916W-161	Power Indicator Light		1
162	HBS916W-162	Start Switch		1
163	HBS916W-163	Stop Switch		1
164	HBS916W-164	Pump Switch		1
165	HBS916W-165S	Feed Control – On/Off Valve (S/N 912484 and lower 1014W)		1
	HBS916W-165S-1	Speed Control – On/Off Valve (S/N 912484 and lower 1014W)		1
	HBS916W-165SP	Plate (not shown)(S/N 912484 and lower 1014W)		1
165N	HBS916W-165N	Feed Control - On/Off Valve (S/N 912485 and higher 1014W)		1
	HBS916W-165N-1	Plate (not shown)(S/N 912485 and higher 1014W)		1
166	HBS916W-166	Connecting Tube		1
166-1	HBS916W-166-1	Hose Clamp		3
168	HBS916W-168G	Control Box		1
169	HBS916W-169	Control Panel		1
170	TS-1533031	Pan Head Screw	M5x10	6
171	HBS1018W-171G	Wheel Box - left		1
172	HBS916W-172	Handle		1
173	TS-1540081	Hex Nut	M12	2
175	TS-1533031	Pan Head Screw	M5x10	2
176	HBS916W-176	Indicator Scale		1
177	HBS916W-177G	Slide Bracket		1
178	HBS916W-178	Tension Shaft		1
179	HBS916W-179	Key	5mm	1
180	HBS916W-180	Handwheel		1
181	HBS916W-181	Lock Washer	M22	13
182	HBS916W-182	Flat Steel Washer		1
183	HBS916W-183	Tension Indicator		1
184	BB-51104	Thrust Bearing		1
187	HBS916W-187G	Slide		1
188	TS-1524021	Set Screw	M8x10	2
189	HBS916W-189	Extension Bar		1
190	HBS916W-190	Wheel Shaft		1
191	TS-1540081	Hex Nut	M12	1
191-1	TS-1523021	Set Screw	M6x8	3
192	TS-1504051	Hex Socket Cap Screw	M8x25	4
192N	TS-1503021	Hex Socket Cap Screw	M6x12	2
193	TS-1492011	Hex Socket Cap Screw	M12x25	1
194	HBS916W-194V	Gib		2
195	HBS916W-195	Hex Cap Screw (re: HBS916W-196)		3
196	HBS916W-196	Screw Assembly		3
196-1	HBS916W-196-1	Lock Washer (re: HBS916W-196)		3
197	HBS916W-197	Hose Fitting		1
198	HBS916W-198	Hose Clamp		1
199	HBS916W-199	Hose Clamp		1
202	HBS916W-202	Power Cord	1 PH	1
	MBS1014W-202	Power Cord	3 PH	1
206	HBS916W-206	Speed Chart Label		1
207	HBS916W-207	Hose		1
208	HBS916W-208	Hose		1
213	TS-1550071	Washer	M10	5
214	HBS1018W-214	Clamp		2
215	HBS1018W-215	Connector		2
216	MBS1014W-216	Fixed Vise Jaw		1

Index No	Part No	Description	Size	Qty
217	MBS1014W-217	Cotter Pin		1
218	MBS1014W-218	Spring Cover		1
219	MBS1014W-219	Adjustable Handle		1
220	MBS1014W-220	Support (S/N 0202755 and lower)		1
220A	MBS1014W-220AG	Support (S/N 0202756 and higher)		1
221	MBS1014W-221	Adjustable Handle		1
222	MBS1014W-222G	Bracket		1
223	MBS1014W-223	Bracket		1
224	MBS1014W-224	Slide		1
225	MBS1014W-225	Guide Plate		1
226	MBS1014W-226G	Turning Slide		1
226A	MBS1014W-226A	Scale		1
227	MBS1014W-227	Bracket		1
228	BB-51106	Thrust Bearing (S/N 0202755 and lower)		1
229	MBS1014W-229	Center Fixed Bracket (S/N 0202755 and lower)		1
230	MBS1014W-230	Turning Slide Bracket (S/N 0202755 and lower)		1
231	MBS1014W-231	Turning Slide (S/N 0202755 and lower)		1
231A	MBS1014W-231A	Turning Slide (S/N 0202756 and higher)		1
232	MBS1014W-232	Turn Plate		1
233	MBS1014W-233G	Coolant Pump Bracket		1
234	TS-1491061	Hex Cap Bolt	M10x40	3
235	TS-1482041	Hex Socket Cap Screw	M6x20	6
236	MBS1014W-236	Washer		1
237	MBS1014W-237	Lock Knob		1
238	MBS1014W-238	Brass Fitting		2
239	TS-1524041	Set Screw	M8x16	1
240	TS-1550101	Washer	M16	2
241	MBS1014W-241	Stop Rod		1
242	MBS1014W-242G	Panel Cover		1
243	TS-1491031	Hex Cap Bolt		2
244	MBS1014W-244	ID Label, Warning Label (not shown)		1
245	MBS1014W-245	Slide Bracket (S/N 01021646 and lower)		1
245N	MBS1014W-245N	Slide Bracket (S/N 01021647 and higher)		1
246	MBS1014W-246	Lead Screw Bracket (S/N 01021646 and lower)		1
246N	MBS1014W-246N	Lead Screw Bracket (S/N 01021647 and higher)		1
247	MBS1014W-247	Rack Block (S/N 01021646 and lower)		1
247N	MBS1014W-247N	Rack Block (S/N 01021647 and higher)		1
248	MBS1014W-248	Rack (S/N 01021646 and lower)		1
248N	MBS1014W-248N	Rack (S/N 01021647 and higher)		1
248N-1	MBS1014W-248N-1	Bushing		1
248N-2	TS-1503041	Hex Socket Cap Screw	M6x25	1
248N-3	TS-1551041	Lock Washer	M6	1
249	MBS1014W-249	Pin		1
250	MBS1014W-250	Pin	4x16	1
	JET-203	JET Logo (not shown)	203 x 84mm	1

14.2.1 MBS-1014W – Gear Speed Reducer Assembly – Exploded View

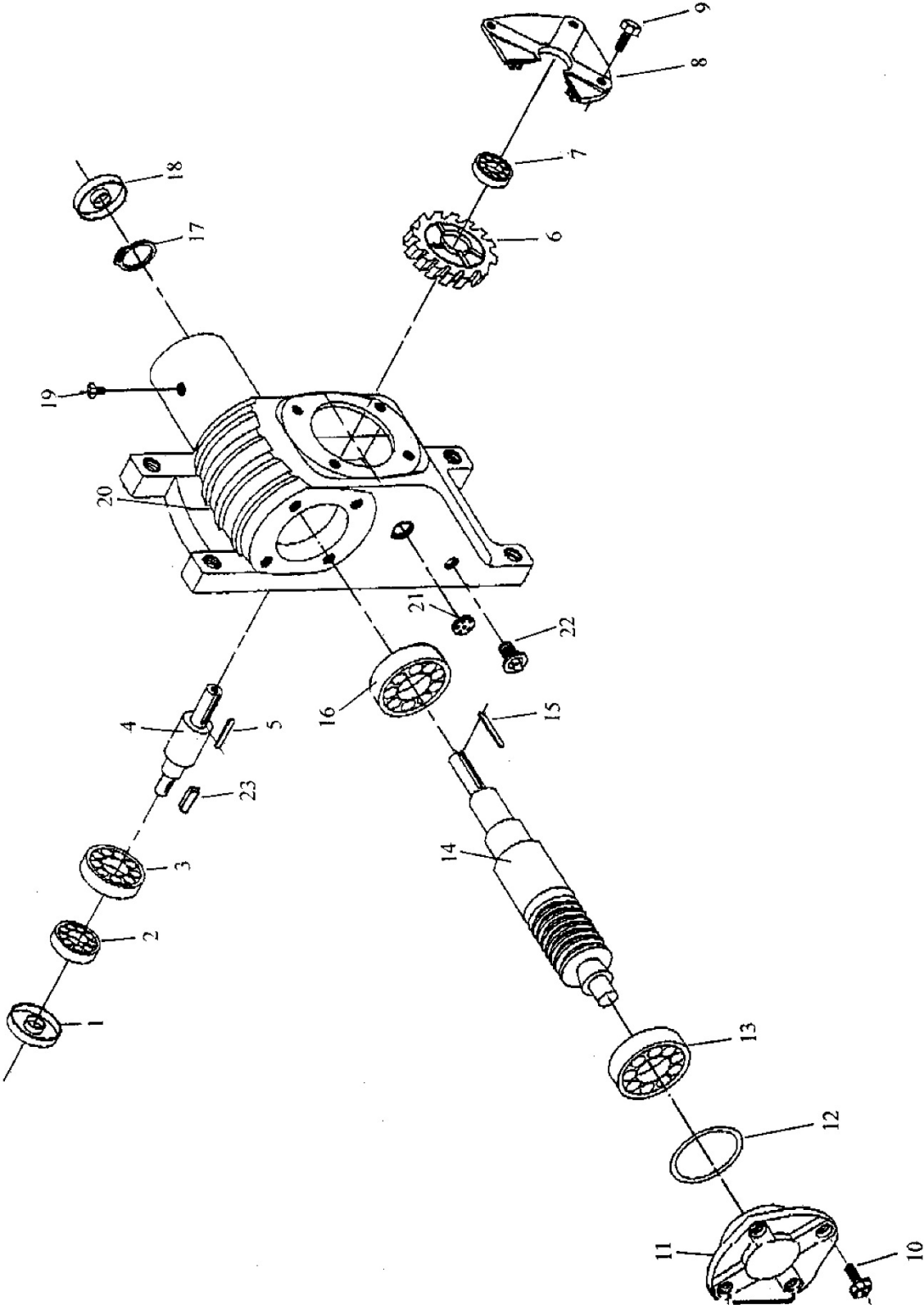

14.2.2 MBS-1014W – Gear Speed Reducer Assembly – Parts List

Index No	Part No	Description	Size	Qty
1	HBS916W-94-01	Oil Seal	35x55x8 mm	1
2	BB-30207	Bearing	30207	1
3	BB-6207	Bearing	6207	1
4	HBS916W-94-04	Shaft		1
5	HBS916W-94-05	Key	8x7x30 mm	1
6	HBS916W-94-06	Gear Wheel		1
7	HBS916W-94-07	Bearing	6206	1
8	HBS916W-94-08	Output Shaft Cover		1
9	HBS916W-94-09	Output Hex Cap Screw	M10x20	4
10	HBS916W-94-10	Input Hex Cap Screw	M8x20	4
11	HBS916W-94-11	Input Shaft Cover		1
12	HBS916W-94-12	Washer		1
13	BB-6025	Bearing	6025	1
14	HBS916W-94-14	Input Shaft		1
15	HBS916W-94-15	Key	7x7x60 mm	1
16	BB-6205	Bearing	6205	2
17	HBS916W-94-17	C-Ring	R52	1
18	HBS916W-94-18	Oil Seal	25x52x8 mm	1
19	HBS916W-94-19	Vent Bolt		1
20	HBS916W-94-20	Gear Box		1
21	HBS916W-94-21	Oil Lens		1
22	HBS916W-94-22	Draw Plug		1
23	HBS916W-94-23	Key	7x7x45 mm	1

15.0 Electrical Connections

15.1.1 Electrical Connections – 1 Phase

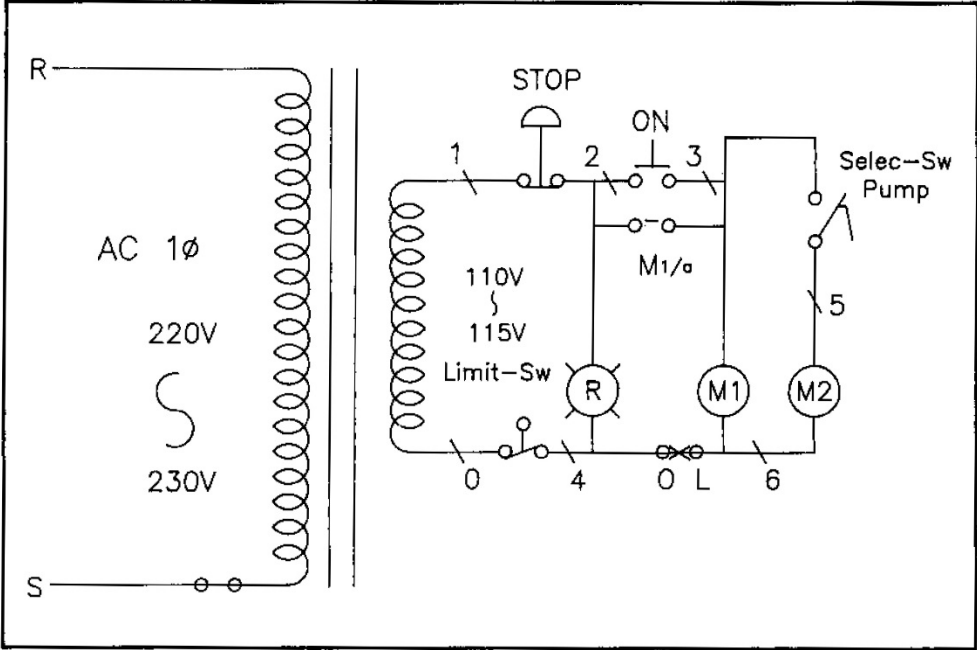

15.1.2 Electrical Panel Layout – 1 Phase

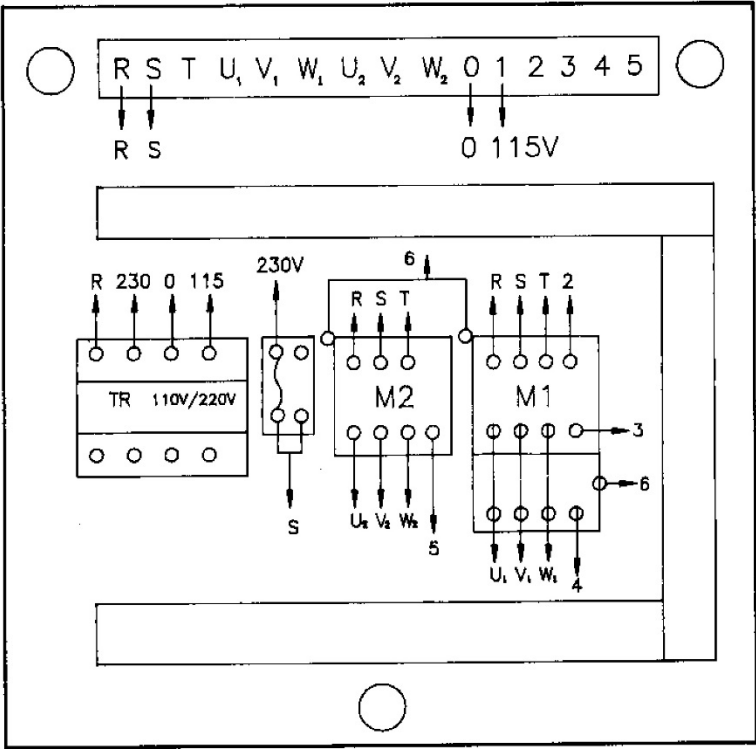

15.2.1 Electrical Connections – 3 Phase

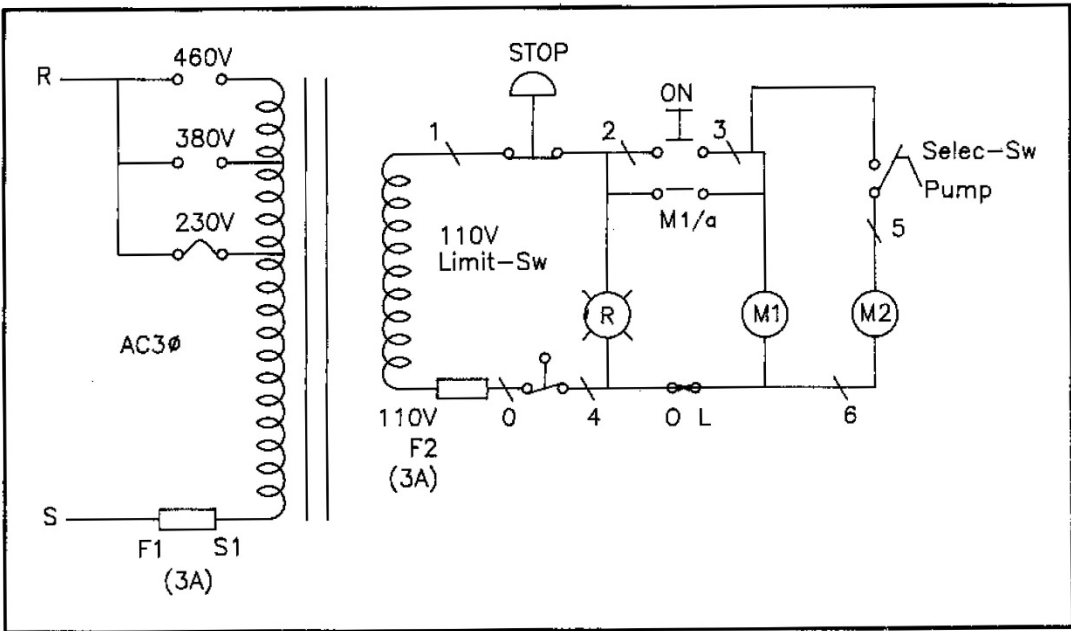

15.2.2 Electrical Panel Layout – 3 Phase

230V

460V

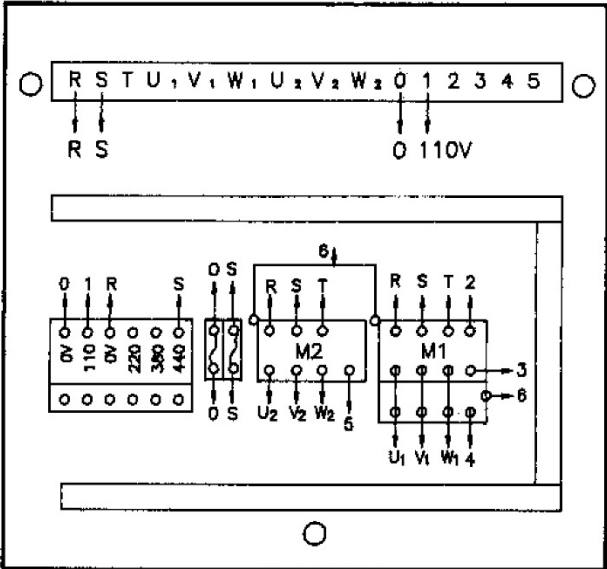
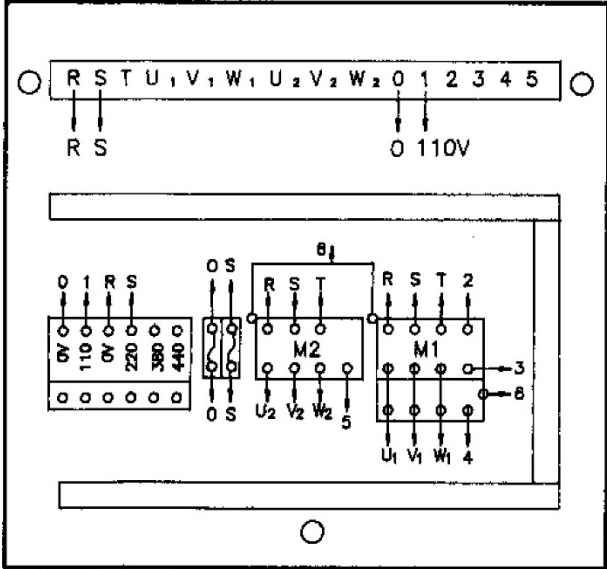



427 New Sanford Road
LaVergne, Tennessee 37086
Phone: 800-274-6848
www.jettools.com