



Operating Instructions and Parts Manual
10-inch x 16-inch Miter Cut-Off Band Saw
Models: J-7020M, J-7040M, J-7040M-4



Model J-7020M shown

JET
427 New Sanford Road
LaVergne, Tennessee 37086
Ph.: 800-274-6848
www.jettools.com

Part No. M-414474
Revision C 01/2016
Copyright © 2015 JET

Warranty and Service

JET warrants every product it sells against manufacturers' defects. If one of our tools needs service or repair, please contact Technical Service by calling 1-800-274-6846, 8AM to 5PM CST, Monday through Friday.

Warranty Period

The general warranty lasts for the time period specified in the literature included with your product or on the official JET branded website.

- JET products carry a limited warranty which varies in duration based upon the product. (See chart below)
- Accessories carry a limited warranty of one year from the date of receipt.
- Consumable items are defined as expendable parts or accessories expected to become inoperable within a reasonable amount of use and are covered by a 90 day limited warranty against manufacturer's defects.

Who is Covered

This warranty covers only the initial purchaser of the product from the date of delivery.

What is Covered

This warranty covers any defects in workmanship or materials subject to the limitations stated below. This warranty does not cover failures due directly or indirectly to misuse, abuse, negligence or accidents, normal wear-and-tear, improper repair, alterations or lack of maintenance. JET woodworking machinery is designed to be used with Wood. Use of these machines in the processing of metal, plastics, or other materials outside recommended guidelines may void the warranty. The exceptions are acrylics and other natural items that are made specifically for wood turning.

Warranty Limitations

Woodworking products with a Five Year Warranty that are used for commercial or industrial purposes default to a Two Year Warranty. Please contact Technical Service at 1-800-274-6846 for further clarification.

How to Get Technical Support

Please contact Technical Service by calling 1-800-274-6846. **Please note that you will be asked to provide proof of initial purchase when calling.** If a product requires further inspection, the Technical Service representative will explain and assist with any additional action needed. JET has Authorized Service Centers located throughout the United States. For the name of an Authorized Service Center in your area call 1-800-274-6846 or use the Service Center Locator on the JET website.

More Information

JET is constantly adding new products. For complete, up-to-date product information, check with your local distributor or visit the JET website.

How State Law Applies

This warranty gives you specific legal rights, subject to applicable state law.

Limitations on This Warranty

JET LIMITS ALL IMPLIED WARRANTIES TO THE PERIOD OF THE LIMITED WARRANTY FOR EACH PRODUCT. EXCEPT AS STATED HEREIN, ANY IMPLIED WARRANTIES OF MERCHANTABILITY AND FITNESS FOR A PARTICULAR PURPOSE ARE EXCLUDED. SOME STATES DO NOT ALLOW LIMITATIONS ON HOW LONG AN IMPLIED WARRANTY LASTS, SO THE ABOVE LIMITATION MAY NOT APPLY TO YOU.

JET SHALL IN NO EVENT BE LIABLE FOR DEATH, INJURIES TO PERSONS OR PROPERTY, OR FOR INCIDENTAL, CONTINGENT, SPECIAL, OR CONSEQUENTIAL DAMAGES ARISING FROM THE USE OF OUR PRODUCTS. SOME STATES DO NOT ALLOW THE EXCLUSION OR LIMITATION OF INCIDENTAL OR CONSEQUENTIAL DAMAGES, SO THE ABOVE LIMITATION OR EXCLUSION MAY NOT APPLY TO YOU.

JET sells through distributors only. The specifications listed in JET printed materials and on official JET website are given as general information and are not binding. JET reserves the right to effect at any time, without prior notice, those alterations to parts, fittings, and accessory equipment which they may deem necessary for any reason whatsoever. JET® branded products are not sold in Canada by JPW Industries, Inc.

Product Listing with Warranty Period

90 Days – Parts; Consumable items; Light-Duty Air Tools
1 Year – Motors; Machine Accessories; Heavy-Duty Air Tools; Pro-Duty Air Tools
2 Year – Metalworking Machinery; Electric Hoists, Electric Hoist Accessories; Woodworking Machinery used for industrial or commercial purposes
5 Year – Woodworking Machinery
Limited Lifetime – JET Parallel clamps; VOLT Series Electric Hoists; Manual Hoists; Manual Hoist Accessories; Shop Tools; Warehouse & Dock products; Hand Tools

NOTE: JET is a division of JPW Industries, Inc. References in this document to JET also apply to JPW Industries, Inc., or any of its successors in interest to the JET brand.

Table of Contents

Cover Page	1
Warranty	2
Table of Contents	3
General Specifications	4
Warning	5-6
Introduction	7
Miter Cut-Off Saw Features	7
Operating Instructions	7
Controls	7
Setting Blade Speed	8
Raising/Lowing Saw Head	8
Controlling the Cut: Hydraulic Feed Control	9
Evaluating cutting Efficiency	9
Blade Selection	9
Break-in procedures	9
Work Set-up	10
Setting Head Angle	10
Securing Workpiece	10
Adjusting the Vise for Angle Cuts	10
Installation and Adjustment of Work Stop	11
Starting the Saw	11
Coolant Flow	11
Coolant Mixture and Quantity	12
Adjustments	12
Blade Tracking Adjustment	12
Factory or Field Procedure	12
Blade Guide Bearing Adjustment	13
Test Cutting to Verify Adjustment Accuracy	14
Adjustment of the Limit Switch	14
Maintenance	14
Cleaning	14
Lubrication	15
Changing Blades	15
Changing the Drive Belt	15
Replacing the Drive Motor	15
Adjusting the Counterbalance Spring	15
Replacing the Drive Wheel	16
Replacing Idler Wheel or Idler Bearing	16
Adjusting the Blade Guides	16
Replacement of Carbide Blade Guide	16
Replacement of Guide Bearings	17
Replacement of Blade Edge Bearings	17
Replacement of the Wire Brush	17
Machine Setup	17
Uncrating and Spotting	17
Electrical	18-19
Troubleshooting	20-21
Replacement Parts	21
Exploded View and Partslist for Saw Base	22-24
Exploded View and Partslist for Saw Head	25-27

General Specifications

The JET Model J-7020M and J-7040M Miter Cut-off Saws cover a wide variety of applications in machine shops, maintenance shops, tool rooms, fabrication and welding shops, and almost any other application requiring a general purpose cut-off band saw. These models offer more standard features designed to provide maximum performance, greater accuracy and more economical operation.

The J-7020M and J-7040M models are equipped with a 45-degree swivel head mitering capability which makes these saws ideally suited for jobs with many angle cuts and limited workshop space. The work piece remains fixed while the head swivels to cut any angle from 0 to 45 degrees and locks with a quick acting lever

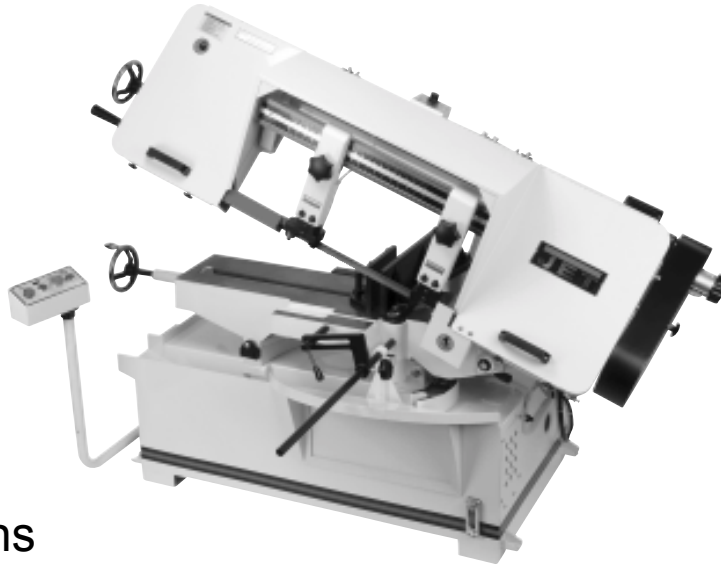

Specifications

Model	J-7020M	J-7040M	J-7040M-4
Stock Number	414474	414475	414484
Cutting Capacity:			
Round @ 90 degree	10 Inches	10 Inches	10 Inches
Rectangle @ 90 degree	10 x14/2x16 Inches	10 x14/2x16 Inches	10 x14/2x16 Inches
Round @ 45 degree	10 Inches	10 Inches	10 Inches
Rectangle @ 45 degree	10x10 Inches	10x10 Inches	10x10 Inches
Blade Size	1x0.035x135 Inches	1x0.035x135 Inches	1x0.035x135 Inches
Blade Speed	100 to 350 Feet/Min.	100 to 350 Feet/Min.	100 to 350 Feet/Min
Blade Wheels	14-Inch Dia. Cast Iron	14-Inch Dia. Cast Iron	14-Inch Dia. Cast Iron
Blade Guides	Adjustable, 6-point Contact, Bearing-and-Guide Type	Adjustable, 6-point Contact, Bearing-and-Guide Type	Adjustable, 6-point Contact, Bearing-and-Guide Type
Drive Motor	110/220VAC/60Hz 1.5 HP/1 Phase	220/440VAC/60Hz 2 HP/3 Phase	460VAC/60Hz 2 HP/3 Phase
Vise	Rapid Acting	Rapid Acting	Rapid Acting
Coolant System	Note 1	Note 1	Note 1
Dimensions:			
Length	79 Inches	79 Inches	79 Inches
Width	31 Inches	31 Inches	31 Inches
Height	41 Inches	41 Inches	41 Inches
Weight (Net)	794 pounds	794 pounds	794 pounds

Note 1: Recirculating system consists of a 1 GPM pump in an 8-gallon reservoir Coolant applied through the blade guides.



WARNING

- Misuse of this machine can cause serious injury
- For safety, machine must be set up, used and serviced properly.
- Read, understand and follow instructions in the Operating Instructions and Parts Manual which was shipped with your machine.

When Setting up Machine:

- Always avoid using machine in damp or poorly lighted work areas.
- Always be sure the machine support is securely anchored to the floor or the work bench.

When Using Machine:

- Always wear safety glasses with side shields (See ANSI Z87.1)
- Never wear loose clothing or jewelry
- Never overreach - you may slip and fall.

When Servicing Machine:

- Always disconnect the machine from its electrical supply while servicing.

- Always follow instructions in Operating Instructions and Parts Manual when changing accessory tools or parts.
- Never modify the machine without consulting JET.

You - the Stationary Power Tool User - Hold the Key to Safety.

Read and follow these simple rules for best results and full benefits from your machine. Used properly JET machinery is among the best in design and safety. However, any machine used improperly can be rendered inefficient and unsafe. It is absolutely mandatory that those who use our products be properly trained in how to use them correctly. They should read and understand the Operating Instructions and Parts Manual as well as all labels affixed to the machine. Failure in following all of these warnings can cause serious injuries.

Machinery General Safety Warnings

1. Always wear protective eye wear when operating machinery. Eye wear shall be impact resistant, protective safety glasses with side shields which comply with ANSI Z87.1 specifications. Use of eye wear which does not comply with ANSI Z87.1 specifications could result in severe injury from breakage of eye protection.
2. Wear proper apparel. No loose clothing or jewelry which can get caught in moving parts. Rubber soled footwear is recommended for best footing.
3. Do not overreach. Failure to maintain proper working position can cause you to fall into the machine or cause your clothing to get caught pulling you into the machine.
4. Keep guards in place and in proper working order. Do not operate the machine with guards removed.
5. Avoid dangerous working environments. Do not use stationary machine tools in wet or damp locations. Keep work areas clean and well lit.
6. Avoid accidental starts by being sure the start switch is OFF before plugging in the machine.
7. Never leave the machine running while unattended. Machine shall be shut off whenever it is not in operation.
8. Disconnect electrical power before servicing. Whenever changing accessories or general maintenance is done on the machine, electrical power to the machine must be disconnected before work is done.
9. Maintain all machine tools with care. Follow all maintenance instructions for lubricating and the changing of accessories. No attempt shall be made to modify or have makeshift repairs done to the machine. This not only voids the warranty but also renders the machine unsafe.
10. Machinery must be anchored to the floor
11. Secure work. Use clamps or a vise to hold work, when practical. It is safer than using your hands and it frees both hands to operate the machine.
12. Never brush away chips while the machine is in operation.
13. Keep work area clean. Cluttered areas invite accidents.
14. Remove adjusting keys and wrenches before turning machine on.
15. Use the right tool. Don't force a tool or attachment to do a job it was not designed for
16. Use only recommended accessories and follow manufacturers instructions pertaining to them.
17. Keep hands in sight and clear of all moving parts and cutting surfaces.
18. All visitors should be kept at a safe distance from the work area. Make the workshop completely safe by using padlocks, master switches, or by removing starter keys.
19. Know the tool you are using - its application, limitations, and potential hazards.

20. Some dust created by power sanding, sawing, grinding, drilling and other construction activities contains chemicals known to cause cancer, birth defects or other reproductive harm. Some examples of these chemicals are:

- Lead from lead based paint
- Crystalline silica from bricks and cement and other masonry products, and
- arsenic and chromium from chemically-treated lumber.

21. Your risk from those exposures varies, depending on how often you do this type of work. To reduce your exposure to these chemicals: work in a well ventilated area, and work with approved safety equipment, such as those dust masks that are specifically designed to filter out microscopic particles.

General Electrical Cautions

This saw should be grounded in accordance with the National Electrical Code and local codes and ordinances. This work should be done by a qualified electrician. The saw should be grounded to protect the user from electrical shock.

Wire Sizes Caution:

For circuits which are far away from the electrical service box, the wire size must be increased in order to deliver ample voltage to the motor. To minimize power losses and to prevent motor overheating and burnout, the use of wire sizes for branch circuits or electrical extension cords according to the following table is recommended.

Conductor Length	AWG (American Wire Gauge) Number	
	240 Volt Lines	120 Volt Lines
0 - 50 Feet	No. 14	No. 14
50 - 100 Feet	No. 14	No. 12
Over 100 Feet	No. 12	No. 8

Safety Instructions on Sawing Systems

1. Always wear leather gloves when handling saw blade. The operator shall not wear gloves when operating the machine.
2. All doors shall be closed, all panels replaced, and other safety guards in place prior to the machine being started or operated.
3. Be sure that the blade is not in contact with the workpiece when the motor is started. The motor shall be started and you should allow the saw to come up to full speed before bringing the saw blade into contact with the workpiece.
4. Keep hands away from the blade area. **See Figure A.**
5. Remove any cut off piece carefully while keeping your hands free of the blade area.
6. Saw must be stopped and electrical supply must be cut off before any blade replacement or adjustment of blade support mechanism is done, or before any attempt is made to change the drive belts or before any periodic service or maintenance is performed on the saw
7. Remove loose items and unnecessary workpieces from area before starting machine.
8. Bring adjustable saw guides and guards as close as possible to the workpiece.
9. Always wear protective eye wear when operating, servicing, or adjusting machinery. Eyewear shall be impact resistant, protective safety glasses with side shields complying with ANSI Z87.1 specifications. Use of eye wear which does not comply with ANSI Z87.1 specifications could result in severe injury from breakage of eye protection. **See Figure B.**
10. Nonslip footwear and safety shoes are recommended. **See Figure C.**
11. Wear ear protectors (plugs or muffs) during extended periods of operation. **See Figure D.**
12. The workpiece, or part being sawed, must be securely clamped before the saw blade enters the workpiece.
13. Remove cut of pieces carefully, keeping hands away from saw blade.
14. Saw must be stopped and electrical supply cut off or machine unplugged before reaching into cutting area.
15. Avoid contact with coolant, especially guarding your eyes.

6

A



B

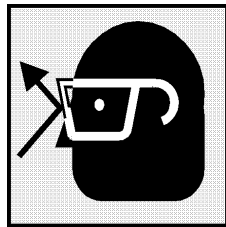

C

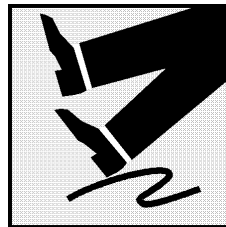

D

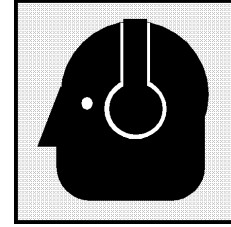

Introduction

This manual includes the operating and maintenance instructions for the JET 10 X 16-inch Miter Cut-Off Saws, Models J-7020M and J-7040M. This manual also includes parts listings and illustrations of replaceable parts for the miter cut-off saws.

Miter Cut-Off Saw Features

Refer to Figures 1 and 2 for key features of the Models J-7020M and J-7040M Miter Cut-Off Saw. The miter cut-off saws are nearly identical to JET's Model J-7020 and J-7040 cut-off saws except that they are equipped with a 45 degree swivel head. The swivel head provides the capability to cut material at angles from 0 to 45 degrees. The swivel head locks and unlocks with a quick acting lever

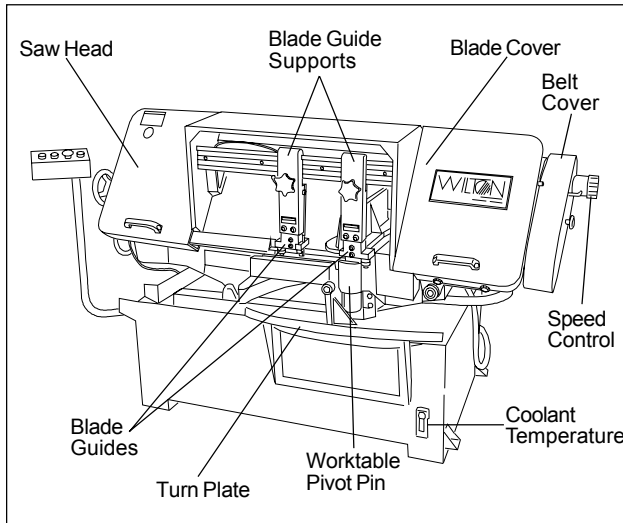

Figure 1: Key Features (Front View)

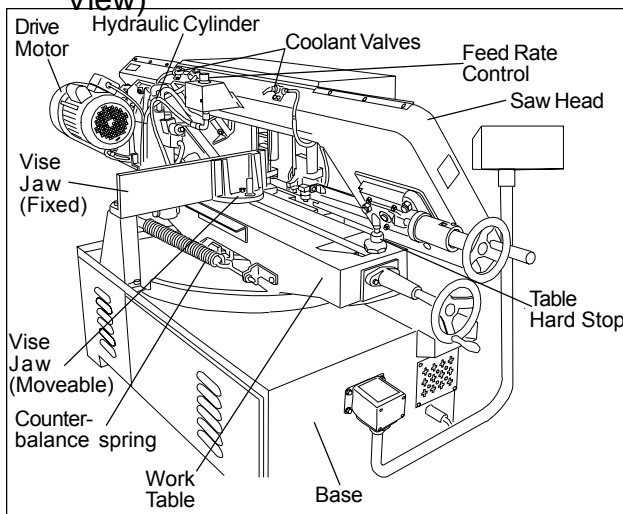

Figure 2: Key Features (Rear View)

Operating Instructions Controls

The operating controls for the saw are provided in a control panel on the left side of the machine. The control panel is mounted on a pivoting tube. The pivoting tube allows the operator to position the control panel in a convenient location.

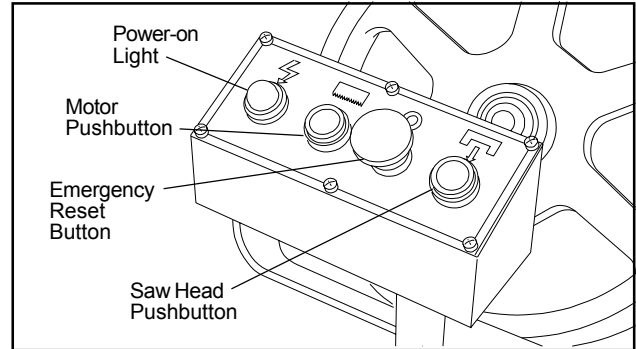

Figure 3: Control panel

1. A power-on light is provided on the left side of the control panel. The power-on light indicates when power is connected to the machine.
2. A large, emergency stop button is provided on the control panel. The emergency stop button provides a means to rapidly cut off electrical power.
3. A saw motor pushbutton switch is provided to the left of the emergency reset button. The sawmotor pushbutton switch starts the saw motor and the E-stop button stops the saw motor.
4. A green pushbutton switch is provided to the right of the emergency stop pushbutton. The pushbutton opens an electro-magnetic valve in the hydraulic cylinder circuit. Opening the valves allows the saw head to move downward and put the saw blade in contact with the workpiece.
5. A red release button on the electro-magnetic valve provides a means to lower the saw head when power to the machine has been disconnected (see figure 6).
6. The rate at which the saw head moves downward is controlled by a hydraulic feed rate control located on the top, rear of the saw head (see figure 5).
7. A coolant pump switch is provided on the electrical equipment box on the back of the machine.
8. The quick acting swivel-head lock (refer to Figure 7) is used to release and lock the swivel-head when making angular material cuts.

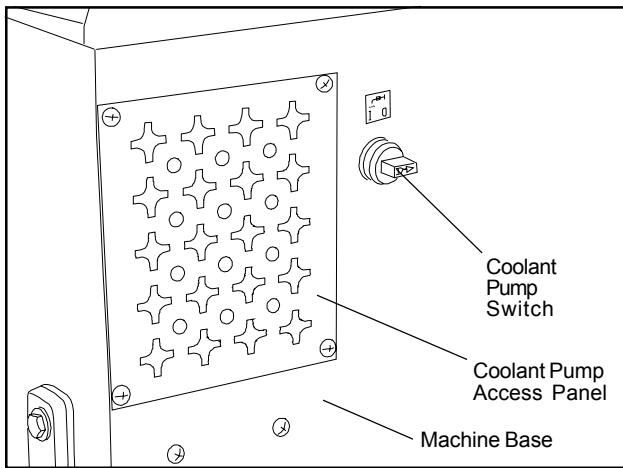

Figure 4: Coolant pump switch

Setting Blade Speed

1. The blade speed is controlled by an adjustment mechanism on the right end of the saw. Speed increases when the adjustment knob is turned counterclockwise. Speed decreases when the knob is turned clockwise.
2. A placard on the drive belt guard (shown below) provides recommended speeds for various materials.
3. A speed indicator is provided on the barrel of the adjustment mechanism. The indicator provides speed indications in feet per minute. (The meters per minute values are shown in parenthesis as following.) The graduations are:

Feet per Minute	Meters per Minute
100	(30)
165	(50)
230	(70)
350	(107)

4. The feed rates on the placard are expressed in feet per minute. The feed rate graduations available on the indicator may not match the recommended feed rate. An approximate speed may therefore be required. For example, to set a speed rate of 130 feet per minute, the indicator would be set about midway between 100 feet-per-minute and 165 feet-per-minute graduations.

WARNING: TO CHANGE SPEED, THE SAW MOTOR MUST BE OPERATING.

5. Turn the speed adjustment knob to desired rate setting as determined by material being cut.

Raising/Lowering Saw Head

1. Lift the saw head using the handle on the far left side of the saw head.
2. To lower the saw head, press the green pushbutton on the right side of the control panel (see figure 3).
3. To adjust the feed rate, adjust the feed rate control valve knob on top of the saw head (see figure 5).

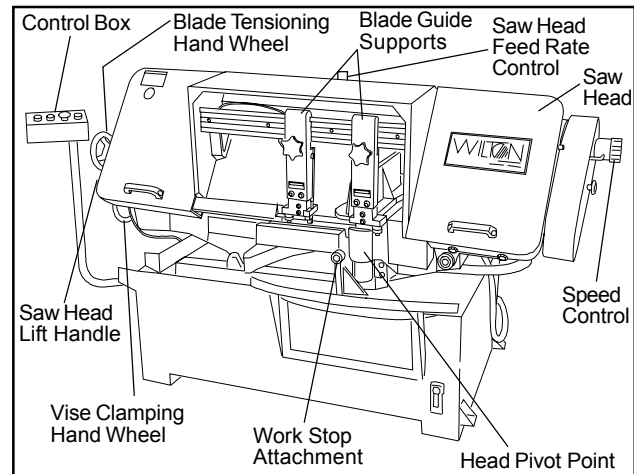

Figure 5: Controls

Variable Speed Adjustment From 100 FPM TO 350 MPM Recommended Speed for Cutting Various Materials

SPEED/FPM	Material To Be Cut
100	Tool Steel, Stainless Steel, Alloy Steel, Phosphor Bronze, Hard Bronze, Hard Cast Iron, Malleable Iron.
165	Mild Steel, Soft Cast Iron, Medium Hard Brass, Medium Hard Bronze.
230	Soft Brasses and Bronzes, Hard Aluminum, Plastics
350	Plastics, Soft and Medium Soft Aluminum, Wood, Other Light Materials

4. To lower the saw head with power off, pull and turn the red knob (manual override) on the electro-magnetic valve (see figure 6).

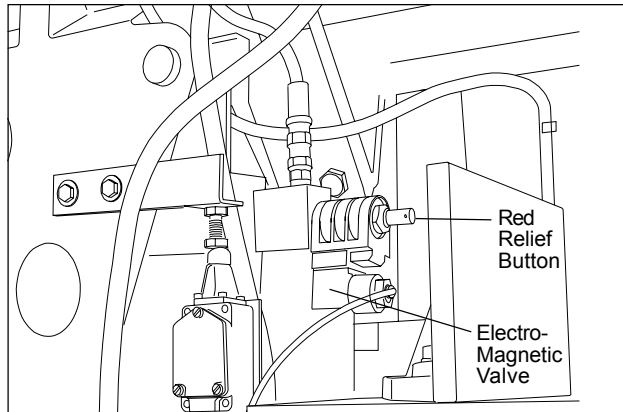

Figure 6: Lowering head with power off

Controlling the Cut: Hydraulic Feed Control

The weight of the saw arm provides all the force needed to move the saw blade through the workpiece. In fact, if the full weight of the arm is allowed to make the cut, rapid blade wear and poor cutting accuracy will result. A hydraulic feed control is provided that gives the operator a means to control the speed and efficiency of cutting.

The hydraulic cylinder is attached between the saw base and the saw head. The hydraulic cylinder resists movement of the saw head in the downward direction. However, the hydraulic cylinder offers no resistance when the saw head is raised upward.

The amount of downward force can be controlled by using the feed rate control valve. When the valve is opened slightly, the saw head will move downward. The further the valve is opened, the faster the saw head will move downward.

The feed control is adjusted by the operator until the saw is operating efficiently. This is usually determined by observing the chip formation. (See Evaluating Blade Efficiency for more information on cutting efficiency.)

Evaluating Cutting Efficiency

Is the blade cutting efficiently? The best way to determine this is to observe the chips formed by the cutting blade.

If the chip formation is powdery then the feed rate is much too light, or the blade is dull.

If the chips formed are curled, but colored — that is, either blue or straw-colored from heat generated during the cut — then the feed rate is too high.

If the chips are slightly curled and are not colored by heat — the blade is sufficiently sharp and is cutting at its most efficient rate.

Blade Selection

The cut-off saw is provided with a saw blade that is adequate for a variety of cut-off jobs on a variety of common materials. A 4/6 vari tooth bi-metal blade (5674011) and a 6/10 vari tooth bi-metal blade (5674021) are available from JET

See **Setting Blade Speed** for the speeds recommended for various materials. These selections, while appropriate for many shop cutting needs, do not encompass the wide variety of blades of special configuration (tooth pitch and set) and special alloys for cutting unusual or exotic materials.

A coarse blade could be used for a solid steel bar but a finer tooth blade would be used on a thin-wall tube. In general, the blade choice is determined by the thickness of the material; the thinner the material, the finer the tooth pitch.

A minimum of three teeth should be on the work piece at all times for proper cutting. The blade and workpiece can be damaged if the teeth are so far apart that they straddle the workpiece.

For very high production on cutting of special materials, or to cut hard-to-cut materials such as stainless steel, tool steel, or titanium, you can ask your industrial distributor for more specific blade recommendations. Also, the supplier who provides the workpiece material should be prepared to provide you with very specific instructions regarding the best blade (and coolant or cutting fluid, if needed) for the material and shape supplied.

Blade Break-in Procedures

New blades are very sharp and, therefore, have a tooth geometry which is easily damaged if a careful break-in procedure is not followed. Consult the blade manufacturer's literature for break-in of specific blades on specific materials. However, the following procedure will be adequate for break-in of JET-supplied blades on lower alloy ferrous materials.

1. Clamp a round section workpiece in the vise. The workpiece should be 2 inches or larger in diameter.
2. Set the saw on low speed. Start the cut with a very light feed rate.
3. When the saw has completed 1/3 of the cut, increase the feed rate slightly and allow the saw to complete the cut.
4. Keep the same hydraulic cylinder setting and begin a second cut on the same or similar workpiece.

- When the blade has completed about 1/3 of the cut, increase the feed rate. Watch the chip formation until cutting is at its most efficient rate and allow the saw to complete the cut (see Evaluating Blade Efficiency). The blade is now considered ready for regular service.

Work Set-up Setting Head Angle

- Move locking lever to the left to unlock swivel-head (refer to Figure 7).
- Move swivel-head to left until pointer is set on desired angle (refer to Figure 8).
- Move locking lever right to lock worktable.

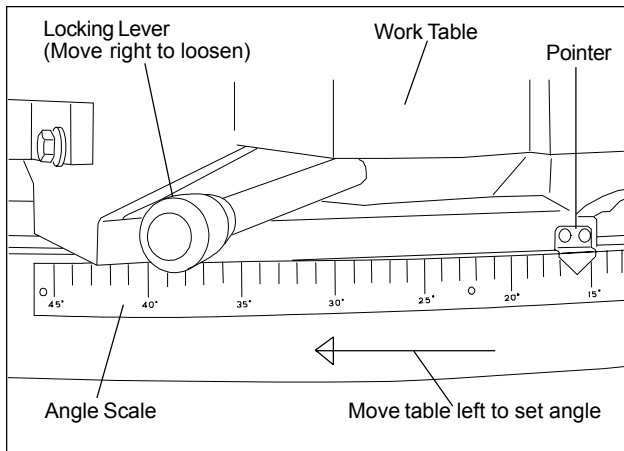

Figure 7: Quick-Acting Swivel-Head Lock

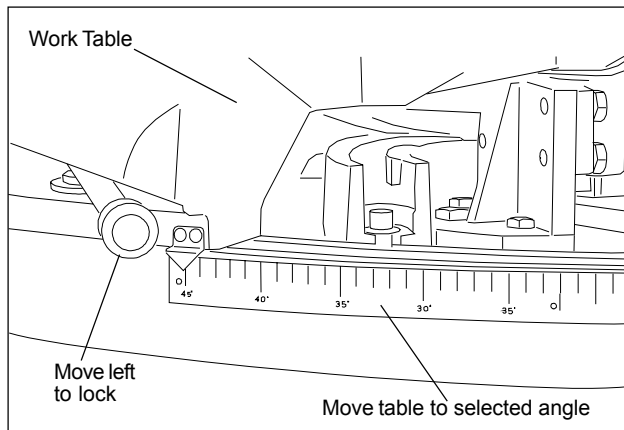

Figure 8: Locking Work Table

Securing Workpiece

- Set work table to desired angle. Lock in place with locking handle.
- Place work piece against fixed jaw (refer to Figure 9).

- Loosen hex post to free moveable jaw. Position the moveable jaw so it is parallel to and in contact with the work piece.
- Using the clamping hand wheel on the worktable, tighten the moveable jaw against the work piece. Then tighten the hex post on the moveable jaw

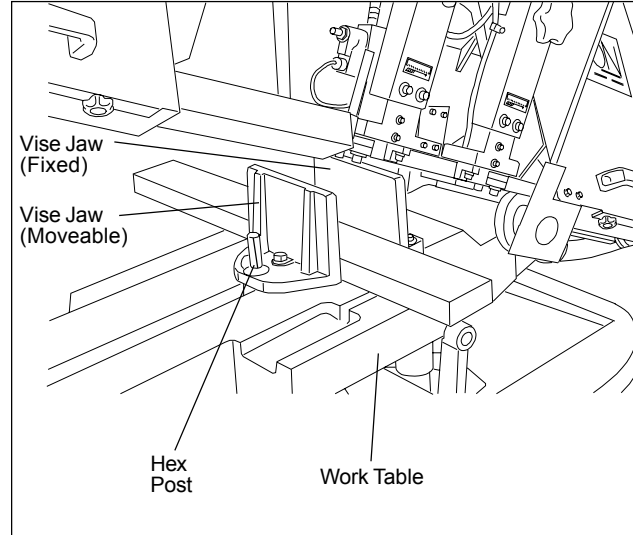

Figure 9: Securing the Workpiece

Adjusting the Vise for Angle Cuts (see figure 9)

- Loosen the angle locking screw and the pivot screw on the left vise jaw.
- Turn the locking handle on the round, angle-setting block counterclockwise to unlock the block. Slide the block until the pointer on the block is aligned with desired angle (see figure 9). Tighten the locking handle to set the angle.
- Set the workpiece in the vise. Put the front end of the workpiece against the corner of the right vise jaw. Put the rear end of the workpiece against the angle-setting block.
- Turn clamping hand wheel clockwise until the left vise jaw is parallel with the workpiece. Tighten the pivot screw and angle locking screw on the left vise jaw. Clamp the workpiece in position.
- After completing the cut, turn the clamping hand wheel counterclockwise and slide the left jaw away from the workpiece.

Installation and Adjustment of Work Stop

The work stop is used to set up the saw for making multiple cuts of the same length (see figure 10). Install and adjust the work stop as follows:

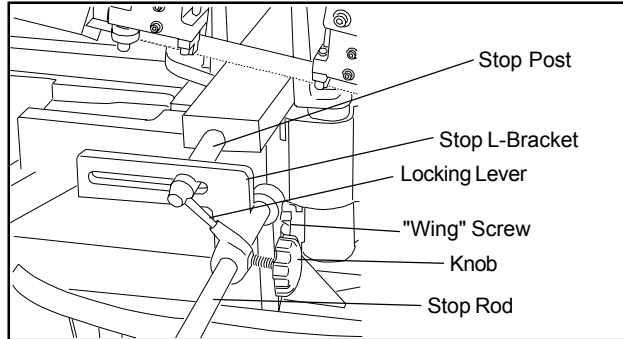

Figure 10: Work stop

1. Insert the end of the stop rod in the hole in the front right side of the work table.
2. Tighten the Wing-screw to secure the rod in place.
3. Install the stop post in the channel on the back of the stop L-bracket. Install the locking lever in the threaded hole in the stop post. Snug-up the locking lever.
4. Install the locking knob in the hole in the side of the stop L-bracket.
5. Slide the assembled stop L-bracket onto the stop rod. Position the stop post against the work piece and tighten the knob in the stop L-bracket. The stop post can be moved left or right as required to place the stop post against the work piece.

Starting the Saw

WARNING: NEVER OPERATE THE SAW WITHOUT BLADE COVERS IN PLACE AND SECURED.

CAUTION: MAKE SURE THE BLADE IS NOT IN CONTACT WITH THE WORKPIECE WHEN THE MOTOR IS STARTED. DO NOT DROP THE SAW HEAD ON THE WORKPIECE OR FORCE THE SAW BLADE THROUGH THE WORKPIECE.

1. Raise the saw head. With the saw motor off, pull the red release button on the electro-magnetic valve and check the rate at which the saw head lowers.
2. Raise the saw head. Push in red release button.
3. Clamp the workpiece in the vise. (See figure 1 for examples of workpieces in the vise.)
4. Be sure the blade is not in contact with the workpiece when the motor is started.

5. Start the motor and allow the saw to come up to speed.
6. Slowly set the saw down onto the workpiece. Adjust cutting speed with the feed rate control valve.
7. DO NOT DROP THE SAW HEAD OR FORCE THE CUT. Let the weight of the saw head provide the cutting force.
8. The saw will automatically shut off at the end of the cut.

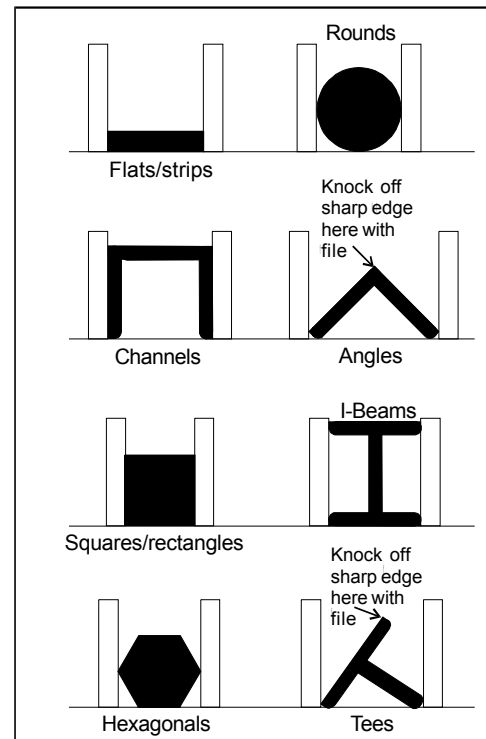

Figure 11: Placing workpieces in the vise

Coolant Flow

CAUTION: THE COOLANT PUMP MUST BE SUBMERGED BEFORE OPERATING TO PREVENT DAMAGE TO THE PUMP.

1. The blade guides are fitted with coolant fittings. Coolant is provided to the fittings through interconnecting tubing. The coolant is dispensed directly onto the saw blade.
2. Adjust the coolant flow valves on the top, rear of the saw head as required to provide the desired flow. The flow should be no more than the blade can draw into the workpiece by movement of the blade.
3. The coolant flow can be stopped in two ways:
 - 1) By using the coolant pump switch on the electrical equipment box, or
 - 2) By closing the coolant flow valves on the top, rear of the saw head.

Coolant Mixture and Quantity

The general purpose coolant is a mixture of water soluble oil and water. Mix one part of soluble oil (TRIM SOL) to ten parts of water (one quart oil, ten quarts of water). The eleven quarts of coolant is the amount required for the coolant pump to operate properly.

There are numerous coolants on the market that are formulated for special applications. Consult your local distributor for details in the event you have a long range production task, or are required to cut some of the more exotic materials.

Adjustments

The efficient operation of the cut-off saw is dependent upon the condition of the saw blade. If the performance of the saw begins to deteriorate, the first item that you should check is the blade.

If a new blade does not restore the machine's cutting accuracy and quality, refer to the Troubleshooting section (or the blade manufacturer's guide) for conditions to consider and adjustments that can be made to increase the life of the blade.

To change the blade, refer to **Changing Blades** in the Maintenance section. To adjust the blade tracking, refer to the following procedures.

Blade Tracking Adjustment

Blade tracking has been tested at the factory. Adjustment is rarely required when the blade is used properly or if the blade is correctly welded. (See figure 12 for location of blade tracking adjustment screws.)

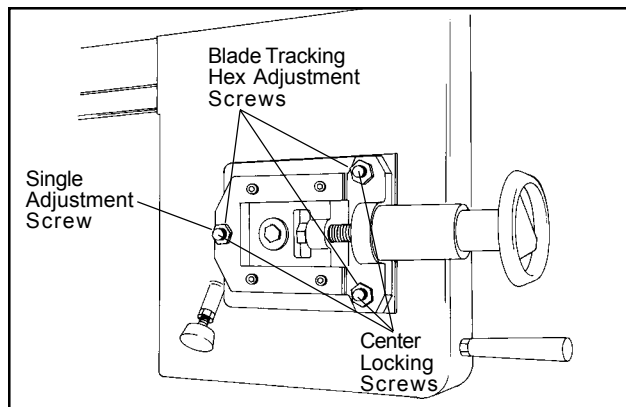

Figure 12: Blade tracking and tensioning
Factory or Field Procedure

1. Raise the saw head enough to allow the saw motor to operate.
2. Loosen four knobs securing the blade cover. Lift the cover and swing it backward.
3. Remove the blade guard mounted on the left blade guide support.
4. Remove both blade guide bearing brackets.
NOTE: Maintain proper tension at all times using the blade tensioning mechanism.
5. Loosen the center locking screws in all three hex adjustment screws on the blade tensioning mechanism (see figure 12).

CAUTION: WHILE PERFORMING THE FOLLOWING, KEEP THE BLADE FROM RUBBING EXCESSIVELY ON THE SHOULDER OF THE WHEEL. EXCESSIVE RUBBING WILL DAMAGE THE WHEEL AND/OR THE BLADE.

6. Start the saw. Slowly turn the single hex adjustment screw at the rear of the tracking mechanism to tilt the idler wheel. Do not turn either of the other two adjustment screws. Turn the adjustment screw until the blade is touching the shoulder of the idler wheel.
NOTE: Turning the screw inward causes the blade to move toward the shoulder of the wheel. Turning the screw outward causes the blade to move away from the shoulder.
7. Turn the single hex adjustment screw so the blade starts to move away from the shoulder of the wheel — then immediately turn the single hex adjustment screw in the other direction so the blade stops, then moves slowly toward the shoulder.

WARNING: KEEP FINGERS CLEAR OF THE BLADE AND WHEEL TO AVOID INJURY.

8. Turn the single hex adjustment screw to stop the motion of the blade on the wheel as it gets closer to the wheel shoulder. Put a 6-inch length of paper between the blade and the wheel as shown in figure 13. The paper should not be cut as it passes between the wheel shoulder and blade.
9. Turn the single hex adjustment screw a small amount. Repeat the insertion of the paper between the wheel shoulder and the blade until the paper is cut in two pieces.

NOTE: You may have to repeat the check with the paper several times before the blade and the shoulder cuts the paper into two pieces. Do not hurry the adjustment. Patience and accuracy here will pay off with better, more accurate, quieter cutting and much longer machine and blade life.

10. When the paper is cut, turn the hex adjustment screw slightly in the counterclockwise direction.

This assures that the blade is not touching the shoulder of the wheel.

11. Shut off the saw.
12. Hold the hex adjustment screws with a wrench and tighten the center locking screws. Make sure the hex adjustment screws do not move while tightening the center screws.
13. Install the two blade guide bearing brackets. Position the guides so the bearings just touch the blade.
14. Install the left blade guard.
15. Close the saw head cover. Tighten the four knobs.

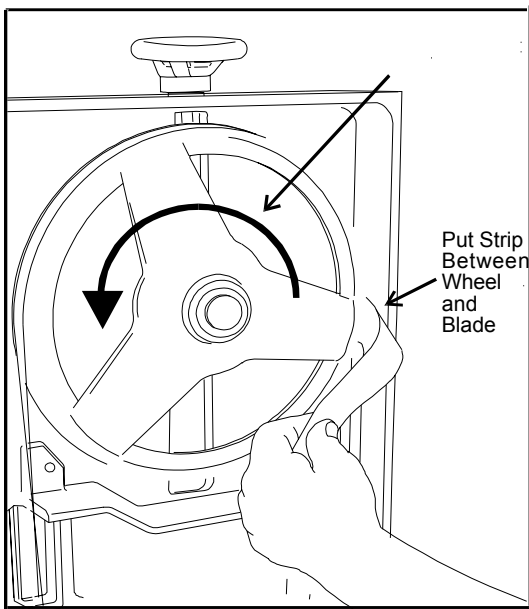

Figure 13: Checking blade-to-wheel clearance using paper strips

Blade Guide Bearing Adjustment

Proper adjustment of the blade guide bearings is critical to efficient operation of the cut-off saw. The blade guide bearings are adjusted at the Factory. They should rarely require adjustment. When adjustment is required, adjust immediately. Failure to maintain proper blade adjustment may cause serious blade damage or inaccurate cuts.

It is always better to try a new blade when cutting performance is poor. If performance remains poor after changing the blade, make the necessary adjustments.

If a new blade does not correct the problem, check the blade guides for proper spacing. For most efficient operation and maximum accuracy provide

0.001 inch clearance between the blade and the guide bearings. The bearings will still turn freely with this clearance. If the clearance is incorrect, the blade may track off the drive wheel.

CAUTION: CHECK THE BLADE TO MAKE SURE THE WELDED SECTION IS THE SAME THICKNESS AS THE REST OF THE BLADE. IF THE BLADE IS THICKER AT THE WELD, THE GUIDE BEARINGS MAY BE DAMAGED.

If required, adjust the guide bearings as follows:

1. The inner guide bearing is mounted on a concentric bushing and can not be adjusted.
2. The outer guide bearing (closest to the operator) is mounted on an eccentric bushing and can be adjusted.
3. Hold the bushing with a 3/4-inch wrench and loosen the center locking screw with an Allen wrench (see figure 14).

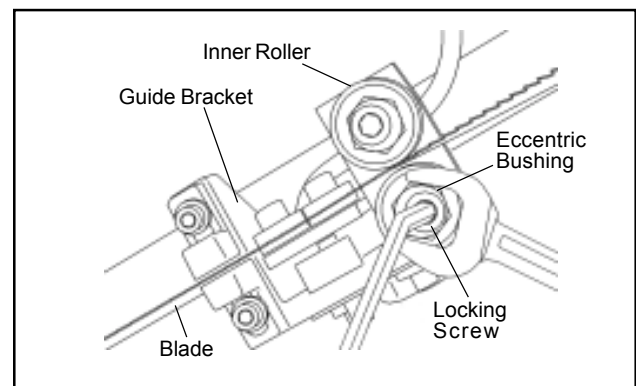

Figure 14: Adjustment of guide bearings

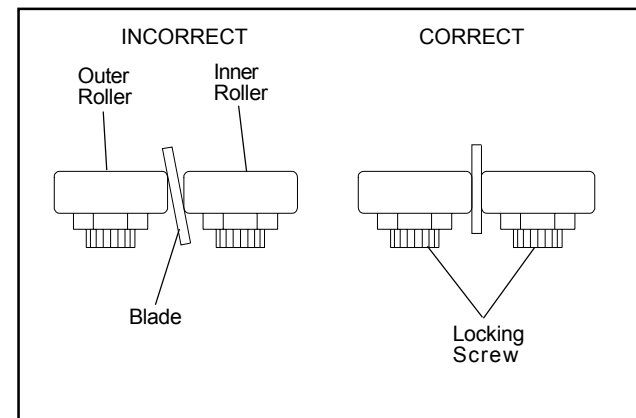

Figure 15: Blade-to-bearing orientation

4. Position the bearing by turning the bushing. Set the clearance at approximately 0.001 inch. The blade should be in a vertical position between the bearings (see figure 15).
5. Tighten the center locking screw with an Allen wrench while holding the eccentric bushing in position with the 3/4-inch wrench.
6. Use the same procedure to adjust the other guide bearing.
7. When the adjustment is correct, the guide bearings should rotate freely with slight pressure of the finger (with the blade stopped).
8. Adjust blade-edge bearings so they just touch the back edge of the blade (see figure 21).

Test Cutting to Verify Adjustment Accuracy

Test cuts can be used to determine whether or not you have adjusted the blade accurately. Use 2-inch round bar stock to perform these test cuts, as follows:

1. With the bar stock securely clamped in the vise, make a cut through the bar stock. (See figure 16.)
2. Mark the top of the bar stock.
3. Move the bar stock about 1/4-inch past the blade so you can begin a second cut.
4. Rotate the bar stock 180 degrees so the mark you made is now at the bottom of the cut.
5. Make a cut through the bar stock.
6. Use a micrometer to measure the thickness variation of the disk you have cut from the bar stock. Measure at the top and bottom of the disk.

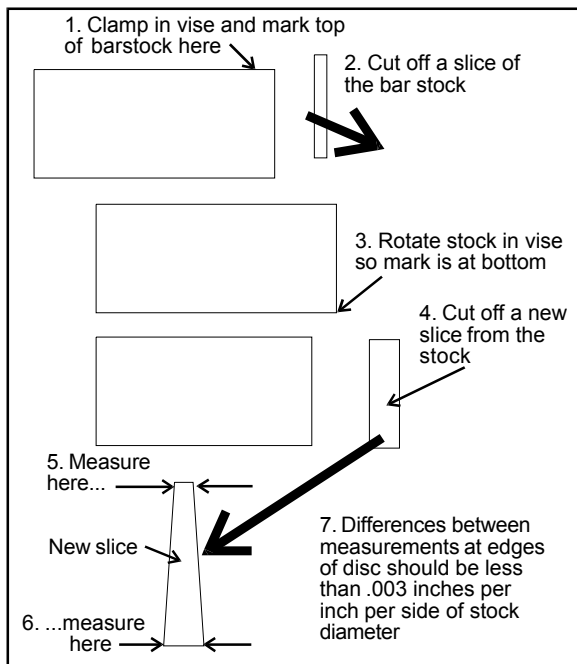

Figure 16: Cutting a test disc

The saw blade can be considered correctly adjusted when the variation measure is no more than 0.012 inch across the face of the disk.

If you do not have a piece of 2-inch bar stock available for a test cut, use a larger diameter test piece rather than a smaller one. The maximum thickness variation on any test piece should be no more than 0.003 inch, per side, per inch of stock diameter.

Adjustment of the Limit Switch

1. The limit switch is provided to shut off the saw motor when the workpiece is cut through.
2. To set the limit switch, loosen the jam nut on the limit switch stop (see figure 15).
3. Adjust the stop as required and retighten the jam nut.

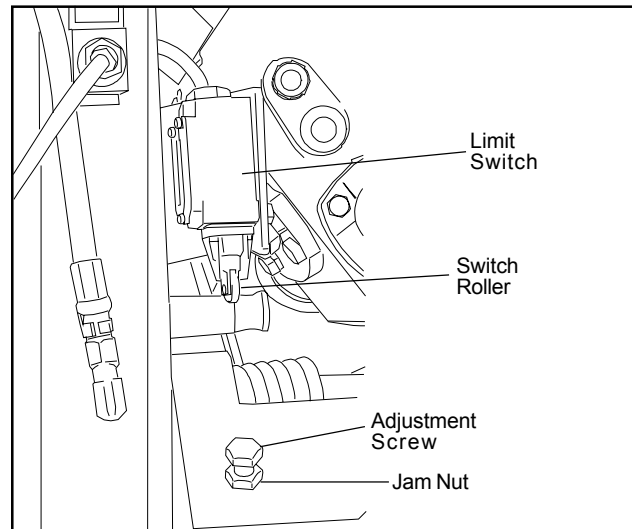

Figure 15: Limit switch adjustment

Maintenance Cleaning

1. Clean off any preservative on machine surfaces.
2. After cleaning, coat the machined surfaces of the cut-off saw with a medium consistency machine oil. Repeat the oil coating process at least every six months.
3. Clean up accumulated saw cuttings after use. Make sure the lead screw is kept free of saw cuttings and other material that would cause damage.
4. Clean the chip sludge from the coolant tank. The frequency should be determined by how often the saw is used.

Lubrication

Lubricate the following components at the specified frequencies and using the lubricants defined below:

1. Ball bearings: the bearings are lubricated and sealed—periodic lubrication is not required.
2. Blade guide bearing: the bearings are lubricated and sealed—lubrication is not required. Inspect periodically.
3. Idler wheel bushing: the bearings are lubricated and sealed—lubrication is not required. Inspect periodically.
4. Lead screw bearing housing: lubricate with light oil monthly (see exploded figure, page 22).
5. Lead screw: lubricate with light oil monthly (see exploded figure, page 20).
6. Hydraulic cylinder pivot: lubricate with light oil every 6 months (see exploded figure, page 22).
7. Blade tension screw: lubricate with grease every 6 months (see exploded figure, page 25).
8. Blade brush bearing: lubricate with light oil monthly (see exploded figure, page 25).
9. Gear box: check oil once a year.
10. Change coolant on a frequency appropriate to the type of coolant being used. Oil based coolants can sour. Refer to the coolant supplier's instructions for change frequency.
11. Coolant tank: clean every 6 months or as required.

Changing Blades

WARNING: SHUT OFF ALL ELECTRICAL POWER TO THE MACHINE.

1. Loosen four knobs securing the blade cover. Lift the cover and swing it backward.
2. Remove the blade guard mounted to the left blade guide support.

WARNING: ALWAYS WEAR LEATHER GLOVES WHEN HANDLING SAW BLADE TO AVOID INJURY FROM THE SAW TEETH.

3. Turn the blade tensioning hand wheel clockwise to relieve tension on the blade. Loosen the blade enough to remove the blade from the idler and drive wheels. Remove the blade from between the blade guides.
4. Install the new blade between the blade guide bearings and the carbide blade guides. Install the blade over the drive and idler wheels.
5. Turn the blade tensioning hand wheel counter-clockwise to tighten the blade. Tighten the blade until the blade tension indicator reads 2000 lbs.
6. Operate the saw at low speed and observe the tracking of the blade. If tracking needs to be adjusted, refer to **Blade Tracking Adjustment**.

7. Adjust the bearings on the upper edge of the blade until they just contact the blade (see figure 21).
8. Check the guide bearings and the carbide guides to make sure they are just contacting the sides of the blade.
9. Install the left blade guard making sure there is ample clearance with the blade.
10. Make a test cut to make sure the blade tracks properly during operation. Adjust tracking as required (see **Blade Tracking Adjustment**).

Changing the Drive Belt

1. Disconnect the electrical power source from the cut-off saw to prevent any possibility of accidental motor start-up.
2. Set the arm at the full horizontal position.
3. Remove the knob on the drive belt cover. Remove the drive belt cover to expose the V-belt and pulleys.
4. Remove two screws, nuts, and washers from back of saw head support. Push on the motor support bracket to pivot the motor upward to loosen the tension on the belt.
5. Remove the worn belt.
6. Put the replacement belt in the pulleys. Allow the motor to pivot downward.
7. Install the two screws, nuts, and washers in back of saw head support and through the motor support bracket.
8. Install the drive belt cover. Install and tighten the knob on the drive belt cover.

Replacing the Drive Motor

1. Disconnect the motor from all electrical power. Unplug the motor if it is plugged into a socket. Shut off the power to the branch and remove the connection to the junction box if the motor is hard wired to the branch.
2. Remove the drive belt from the drive motor pulley (see **Changing the Drive Belt**).
3. Remove motor pulley.
4. Open the motor junction box and disconnect the power cord wires from their terminals.
5. Remove the nuts, washers and bolts that secure the motor to the mounting plate.
6. Installation of a new motor is a reversal of the above steps.

Adjusting the Counterbalance Spring

The counterbalance spring is located at the right, rear of the saw head. The counterbalance spring is used to adjust the amount of down force the saw head puts

on the workpiece when the feed rate control valve is fully open.

1. Raise the saw arm to its full upright position and lock it in position (refer to Figure 18).

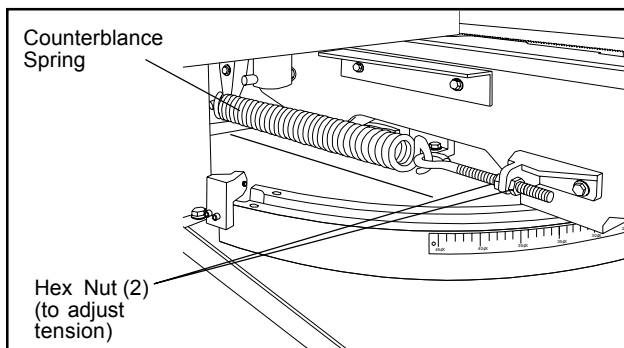

Figure 18: Counterbalance Spring Adjustment

2. To adjust the tension on the spring, loosen the two nuts on the threaded rod of the spring pivot post. Adjust the tension as required.
3. Tighten the two nuts against the pivot post.
4. The saw can now be returned to service.

Replacing the Drive Wheel

1. Remove the blade (see **Changing Blades**).
2. Remove the screw, spring washer, and washer from the speed reducer shaft.
3. Pull the wheel from the speed reducer shaft. Remove the drive key from the speed reducer shaft.
4. Inspection: Examine drive edge and shoulder of the wheel for damage. Replace the wheel if damaged.
5. Install the key in the keyway in the speed reducer shaft. Align the keyway in the wheel with the key in the speed reducer shaft. Reinstall the wheel on the speed reducer shaft.
6. Install the screw, spring washer and washer in the end of the speed reducer shaft.
7. Install the blade (see **Changing Blades**).

Replacing Idler Wheel or Idler Bearing

1. Remove the saw blade (see **Changing Blades**).
2. Remove the screw, spring washer, and washer from the idler shaft.
3. Remove the idler wheel. Remove the bearing from the idler wheel.
4. Inspection: Examine the drive edge and shoulder of the idler wheel for damage. Replace the wheel if damaged.

5. Inspect bearings for damage and smooth operation, Replace if faulty.
6. Install the bearing in the idler wheel. Install the idler wheel on the idler shaft.
7. Install the screw, spring washer and washer in the idler shaft.
8. Install the blade (see **Changing blades**).

Adjusting the Blade Guides

The cut-off saw has adjustable blade guide supports (see figure 19). The blade guide supports allow you to set the blade guides for varying widths of workpieces. To make accurate cuts and prolong blade life, the blade guide supports should be set to just clear the workpiece to be cut.

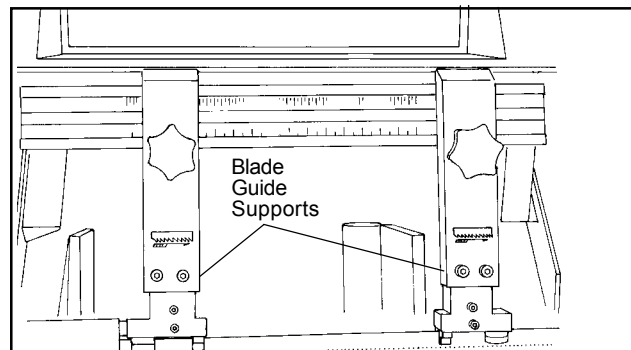

Figure 19: Blade guide supports

1. Loosen the knob on the blade guide support and slide the guide left or right as required. Repeat for the other blade guide.
2. Set the blade guide supports as required to accommodate the width/diameter of the workpiece. The blade guides should be positioned so the guides do not contact the workpiece as the saw head moves downward through the workpiece.

Replacement of Carbide Blade Guide (see figure 20)

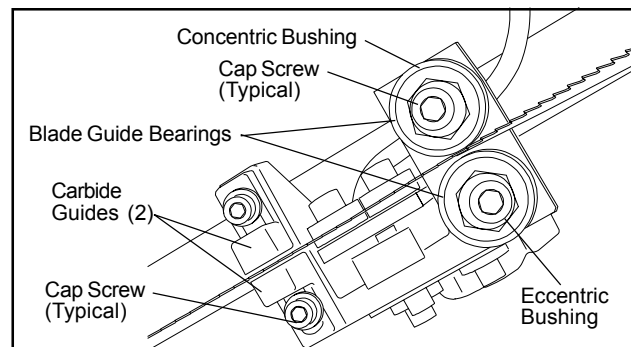

Figure 20: Carbide blade guides and guide bearings

1. Remove the cap screw and remove the carbide guide. Discard the carbide guide.
2. Install the replacement carbide guide on the guide bearing support. Install the cap screw. Set the guide so it just contacts the side of the saw blade.
3. Using a machinist's square, check squareness of the blade to the table.

Replacement of Guide Bearings (see figure 20)

1. Remove the cap screw from the bearing being replaced. Separate the bushing and cap screw from the bearing. Discard the bearing.
- NOTE:** There is a light press fit between the bearing and the bushing.
2. Install bushing in replacement bearing. Install cap screw through bushing and into guide support.
 3. If the bearing being replaced is on an eccentric bushing, install the bearing on the operator side of the blade.
 4. Turn the eccentric bushing in the guide support until the bearing contacts the blade.

Replacement of Blade Edge Bearings

1. Remove the capscrew from the blade edge bearing being replaced and discard the bearing. Be careful not to lose the spring washer that separates the bearing from the floating block (see figure 21).
2. Insert the capscrew into the new bearing. Replace the spring washer onto the capscrew and re-install into the floating block.
3. If re-adjustment is necessary loosen the pivot capscrew and move the floating block so that the blade edge is close to the guide support, but cannot touch the bottom surface of it when the sawblade is cutting a workpiece.

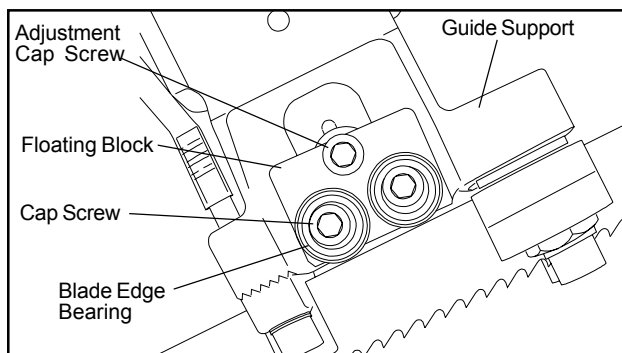

Figure 21: Blade edge bearing replacement

Replacement of the Wire Brush

1. Loosen four knobs securing the blade cover. Lift the cover and swing it backward.
2. Remove the attaching screw, spring washer and washer. Remove and discard the brush (see figure 22).
3. Install replacement brush and secure with screw, spring washer and washer.
4. Close the blade cover and secure with four knobs.

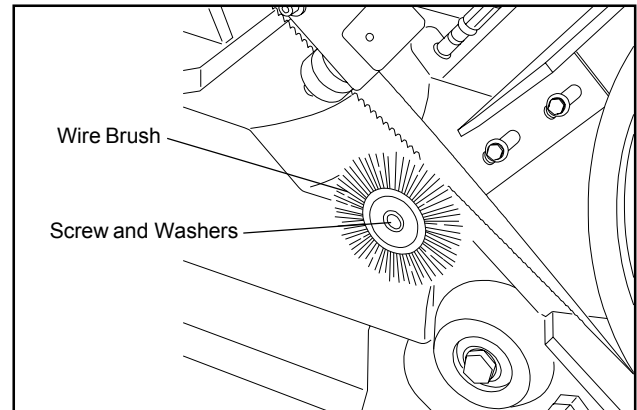

Figure 22: Wire brush

Machine Setup

The saw delivered to you has been adjusted at the factory. A number of test pieces have been cut using the saw to verify the accuracy of cutting. Therefore, the only setup operations required before releasing the saw for service are spotting the saw and establishing the electrical connections to the motor.

Uncrating and Spotting

Spot the saw where it makes the most sense for the operations you will probably be doing. If you are going to be doing cut-off work on very long pieces of stock, allow plenty of room for the stock, and the infeed and outfeed supports. Remove the saw from the shipping skid and discard any hold-down devices that were used to secure the saw to the skid.

Electrical

Observe the following when connecting to the power source. (Refer to the wiring diagrams in Figures 23 - 26.)

WARNING: JET RECOMMENDS THAT ANY HARD WIRING OF THE SAW TO A BRANCH, OR ANY CHANGE OF VOLTAGE SUPPLIED TO THE MOTOR BE PERFORMED BY A LICENSED ELECTRICIAN.

1. Make sure the saw is disconnected from the power source, or that the fuses have been removed or breakers tripped in the circuit in which the saw will be connected. Make sure you put a warning placard on the fuse or circuit breaker to prevent accidental electrical shock.
2. If you are installing the motor power cord into a receptacle, make sure to use the appropriate plug.
3. If you are using hard-wired connections to a junction box, connect the wires in the box, and close the box.
4. Install the fuses or reset the breaker
5. The saw is now ready for service.

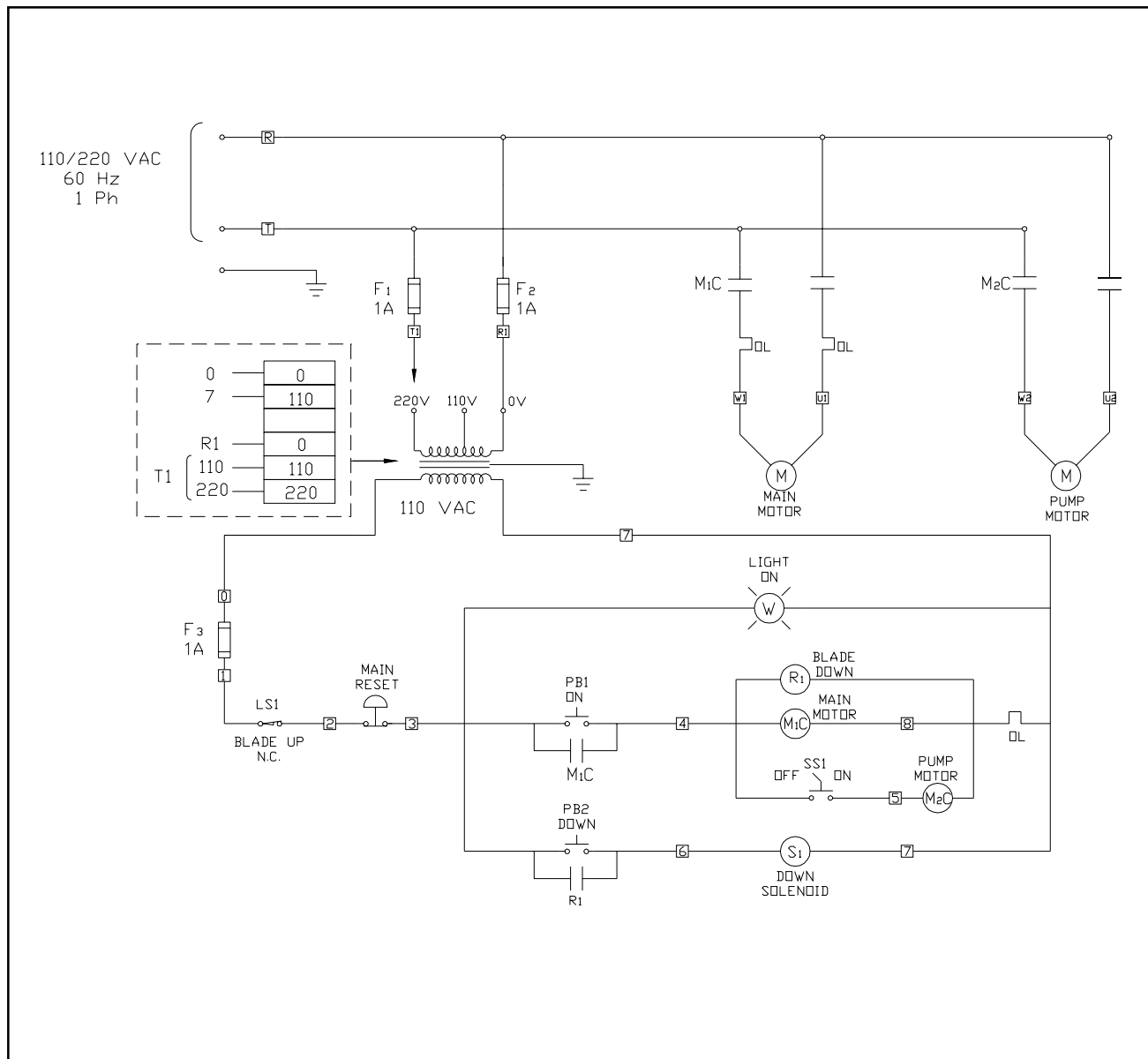
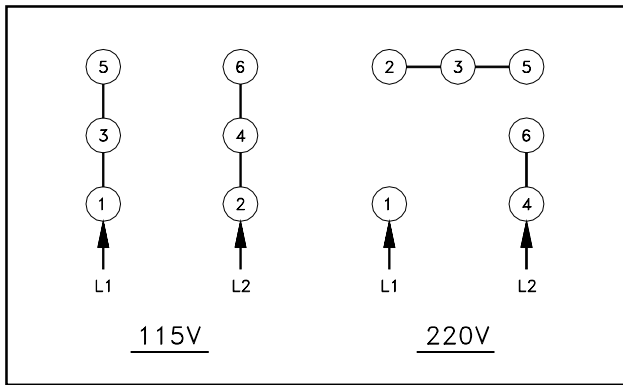

Figure 23: Model J-7020M cut-off saw wiring diagram



115V - To reverse motor rotation
switch terminal 5 and 6.

220V - To reverse motor rotation
hook terminal 6 to 1.

Figure 24: Connection diagram for 1ph motor

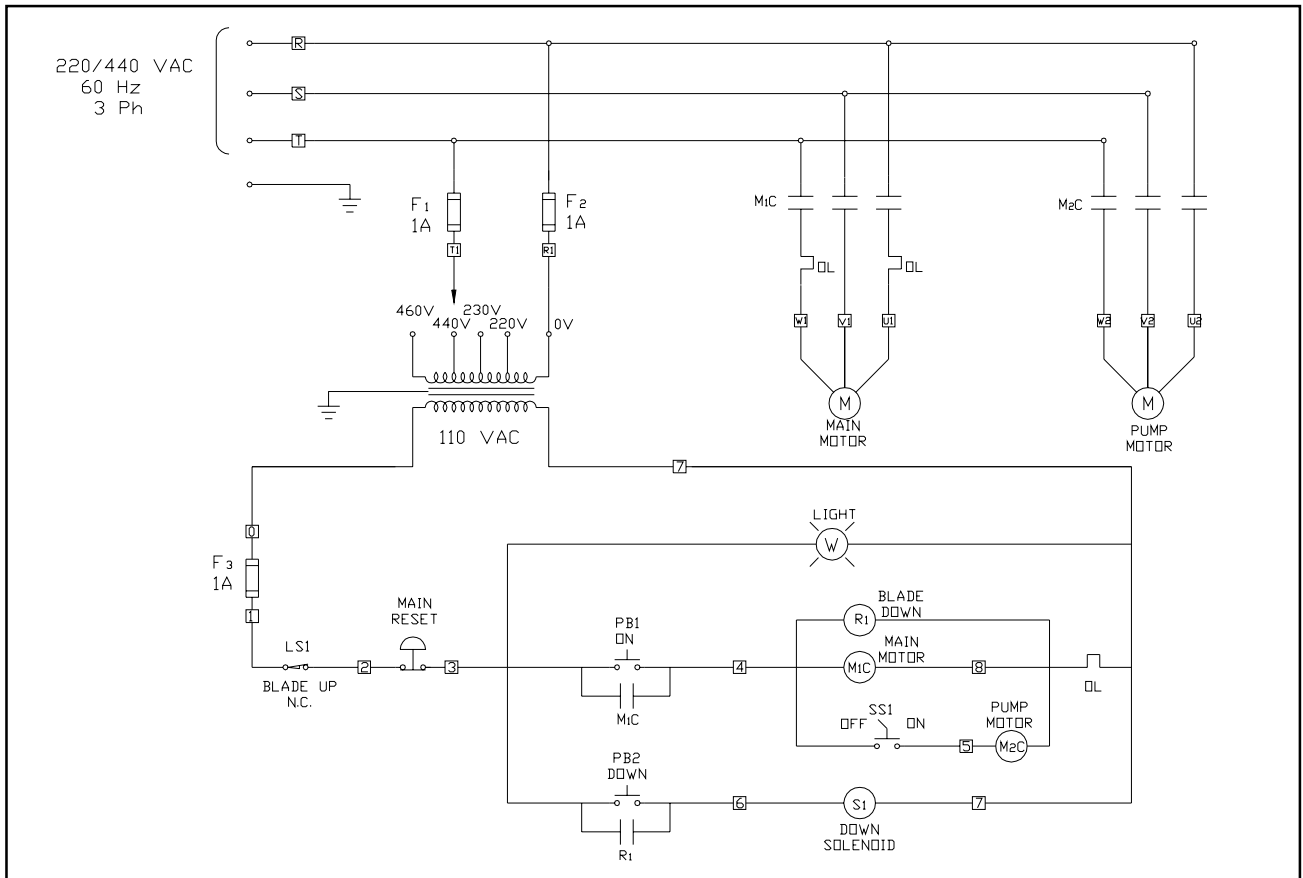

Figure 25: Model 7040M cut-off saw wiring diagram

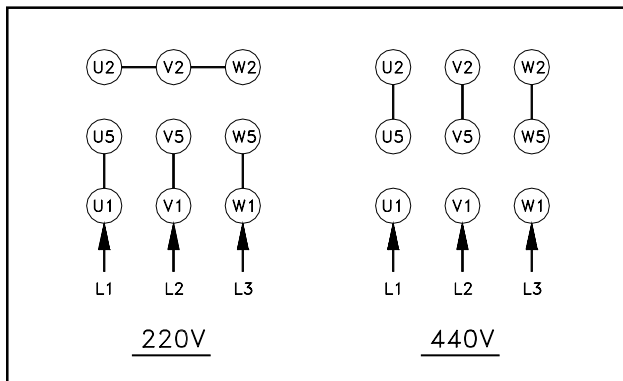

Figure 26: Connection diagram for 3ph motor

Troubleshooting

Fault	Probable cause	Suggested remedy
Excessive blade breakage	<ol style="list-style-type: none"> 1. Material loose in vise. 2. Incorrect speed or feed. 3. Teeth too coarse for material. 4. Incorrect blade tension. 5. Saw blade is in contact with workpiece before the saw is started. 6. Blade rubs on the wheel flange. 7. Misaligned guides. 8. Cracking at weld. 	<ol style="list-style-type: none"> 1. Clamp work securely. 2. Check Machinist's Handbook for speed/feed appropriate for the material being cut. 3. Check Machinist's Handbook for recommended blade type. 4. Adjust blade tension to the point where the blade just does not slip on the wheel. 5. Start the motor before placing the saw on the workpiece. 6. Adjust blade tracking. 7. Adjust guides. 8. Longer annealing cycle.
Premature blade dulling	<ol style="list-style-type: none"> 1. Blade teeth too coarse. 2. Blade speed too high. 3. Inadequate feed pressure. 4. Hard spots in workpiece or scale on/in workpiece. 5. Work hardening of material (especially stainless steel). 6. Insufficient blade tension. 7. Operating saw without pressure on workpiece. 	<ol style="list-style-type: none"> 1. Use a finer tooth blade. 2. Try a lower blade speed. 3. Decrease spring tension. 4. Increase feed pressure (hard spots). Reduce speed, increase feed pressure (scale). 5. Increase feed pressure by reducing spring tension. 6. Increase tension to proper level. 7. Do not run blade at idle in/on material.
Bad cuts (out-of-square)	<ol style="list-style-type: none"> 1. Workpiece not square with blade. 2. Feed pressure too fast. 3. Guide bearings not adjusted properly. 4. Inadequate blade tension. 5. Span between the two blade guides too wide. 6. Dull blade. 7. Incorrect blade speed. 8. Blade guide assembly is loose. 9. Blade guide bearing assembly loose. 10. Blade track too far away from wheel flanges. 11. Guide bearing worn. 	<ol style="list-style-type: none"> 1. Adjust vise so it is square with the blade. (Always clamp work tightly in vise.) 2. Decrease pressure. 3. Adjust guide bearing clearance to 0.001 inch (0.002 inch maximum). 4. Gradually increase blade tension. 5. Move blade guide bar closer to work. 6. Replace blade. 7. Check blade speed (see Figure 3). 8. Tighten blade guide assembly. 9. Tighten blade guide bearing assembly. 10. Adjust blade tracking. 11. Replace worn bearing.
Bad cuts (rough)	<ol style="list-style-type: none"> 1. Blade speed too high for feed pressure. 2. Blade is too coarse. 	<ol style="list-style-type: none"> 1. Reduce blade speed and feed pressure. 2. Replace with finer blade.

NOTE: Troubleshooting continued on next page

Blade is twisting	<ol style="list-style-type: none"> 1. Blade is binding in the cut. 2. Blade tension too high. 	<ol style="list-style-type: none"> 1. Decrease feed pressure. 2. Decrease tension on blade
Unusual wear on side/back of blade	<ol style="list-style-type: none"> 1. Blade guides worn 2. Blade guide bearings not adjusted. 3. Blade guide bearing bracket is loose. 	<ol style="list-style-type: none"> 1. Replace blade guides. 2. Adjust blade guide bearings. 3. Tighten blade guide bearing bracket.
Teeth missing/ripped from blade	<ol style="list-style-type: none"> 1. Blade tooth pitch too coarse for workpiece. 2. Feed too slow; feed too fast. 3. Workpiece vibrating. 4. Gullets loading up with chips. 	<ol style="list-style-type: none"> 1. Use blade with finer tooth pitch. 2. Increase feed pressure and/or blade speed. 3. Clamp workpiece securely. 4a. Use blade with a coarse tooth pitch—reduce feed pressure. 4b. Brush blade to remove chips.
Motor running too hot	<ol style="list-style-type: none"> 1. Blade tension too high. 2. Drive belt tension too high. 3. Blade too coarse for workpiece (especially with tubular stock). 4. Blade too fine for workpiece (especially with heavier, soft material). 5. Speed reducer gears require lubrication. 	<ol style="list-style-type: none"> 1. Reduce tension on blade. 2. Reduce tension on drive belt. 3. Use blade with fine tooth pitch. 4. Use blade with coarse tooth pitch. 5. Check speed reducer.
No coolant flow	<ol style="list-style-type: none"> 1. Pump motor is burned out. 2. Screen/filter on pump is clogged. 3. Impeller is loose. 4. Coolant level too low. 	<ol style="list-style-type: none"> 1. Replace pump. 2. Clean screen/filter. 3. Tighten impeller. 4. Add coolant to reservoir.
Excessive speed reducer noise/vibration	<ol style="list-style-type: none"> 1. V-belt is too tight. 2. Countering spring not tensioned properly. 	<ol style="list-style-type: none"> 1. Reset V-belt tension. 2. Increase spring tension.

Replacement Parts

This section provides exploded view illustrations that show the replacement parts for the 10-inch x 16-inch Cut-Off Saw. Also provided are parts listings that provide part number and description. The item numbers shown on the illustration relate to the item number in the facing parts listing.

Order replacement parts from:

JET
427 New Sanford Road
LaVergne, Tennessee 37086
Ph.: 800-274-6848

Identify the replacement part by the part number shown in the parts listing. Be sure to include the model number and serial number of your machine when ordering replacement parts to assure that you will receive the correct part.

Exploded View - Model J-7020M/J-7040M Miter Cut-off Saw Base

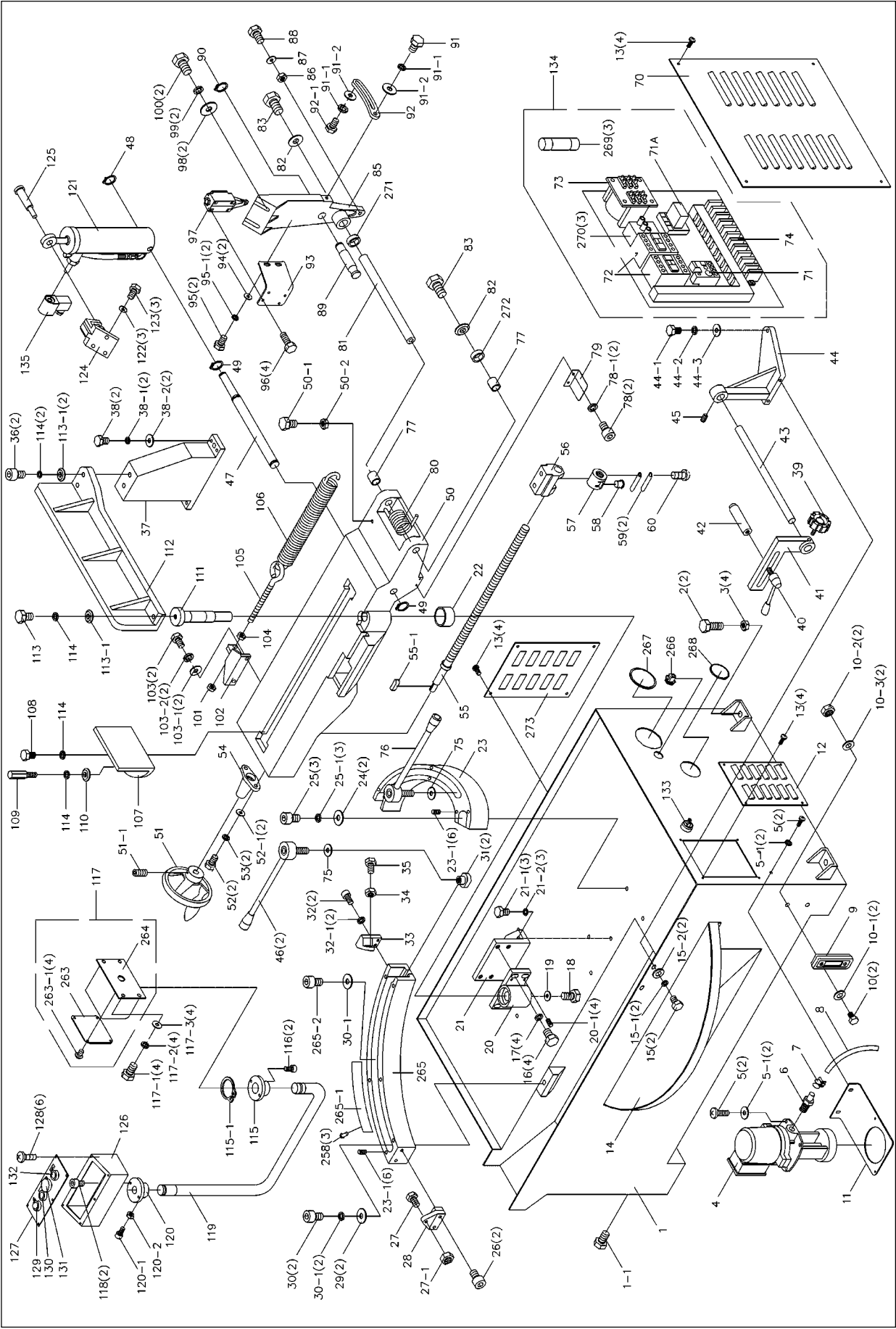

Exploded View - Model J-7020M/J-7040M Miter Cut-off Saw Base

Parts List - Model J-7020M/J-7040M Miter Cut-off Saw Base

ITEM NO.	PART NO.	DESCRIPTION	QTY	ITEM NO.	PART NO.	DESCRIPTION	QTY
1	J-5507591G	Base, Machine	1	40	5712441	Handle, Lock	1
1-1	5512197	Plug, Drain (3/8in, PT)		41	5712421	Work Stop Bracket	1
2	5507592	Screw, Cap, 12 x 70	4	42	5712451	Stop, Work	1
3	5507593	Nut, Hex, M12	4	43	5712431	Rod, Work Stop	1
4		Pump, Coolant	1	44	J-5507628G	Support	1
	J-5712281	115/220V, 1 Phase		44-1	TS-1482061	Screw, Cap, (M6 x 30)	1
	J-5712921A	220/440V, 3 Phase		44-2	5516257	Washer, Lock, M6	1
*	5512101	Filter Screen w/Screw	1	44-3	5516253	Washer, M6	1
5	5507595	Screw, Slotted, M6 x 16	4	45	5507629	Screw, Set	1
5-1	5507607	Flat Washer, M12	4	46	5507630	Handle, Adjustable	2
6	5507596	Fitting, Hose	1	47	5507631	Pin, Cylinder	1
7	5507597	Clamp, Hose	1	48	5507632	C-Ring, S-20	1
8	5712331	Hose 5/16	1	49	5507633	C-Ring, S-25	2
9	5507599	Gauge, Coolant	1	50	J-5507634G	Bed	1
10	5507600	Bolt, Hex, M10 x 30	2	50-1	TS-1491041	Bolt, Hex, M10 x 30	1
10-1	5507599-1	Washer, Cotton, M10	2	50-2	5507619	Nut, Hex, M10	1
10-2	TS-1540071	Nut Hex M10	2	51	5712471	Hand Wheel Assembly	1
10-3	5507613	Flat Washer, M10	2	51-1	TS-0051011	Screw, Set, 5/16" x 1/2"	1
11	5712351	Bracket, Pump, Coolant	1	52	5507636	Bolt, Hex, M8 x 30	2
12	5507602G	Cover, Panel	1	52-1	5507668	Flat Washer, M8	2
13	5507603	Screw, Pan Head, 1/4" x 3/8'	12	53	5507637	Washer, Lock, M8	2
14	J-5507604G	Tray, Drip	1	54	5712481G	Lead Screw Bracket	1
15	5507605	Bolt, Hex, M8 x 16	2	55	5712511	Vice Lead Screw	1
15-1	5507637	Washer, Lock, M8	2	55-1		Key, 5 x 5 x 20mm	1
15-2	5507668	Flat Washer, M8	2	56	5712521	Lead Screw Bracket	1
16	5507606	Bolt, Hex, M12 x 30	4	57	5712531	Nut, Acme	1
17	5507607	Washer, Flat, M12	4	58	5712541	Acme Nut Button	1
18	5512701	Bolt, Hex M8 x 16	1	59	5712551	Acme Nut Retainer	2
19	5507608	Washer, Flat	1	60	5712561	Screw Pn Hd PhlpsM5 x 8	1
20	5507609G	Bracket, Turning Slide	1	70	5507646G	Panel, Electrical, Access	1
20-1	5516251	Screw, Set, M8 x 10	4	71		Overload	1
21	5507610G	Bracket, Center Fixed	1		5507542	115V, 1-Phase	
21-1	TS-1492031	Bolt, Hex, M12 x 35	3		5713031	220V, 1-Phase	
21-2	5516256	Washer, Lock, M12	3		5512660	220V, 3-Phase	
22	5507611	Bearing, Thrust	1		5712661	440V, 3-Phase	
23	J-5507612G	Slide, Turning, Right	1	71A	5508409	Relay, 115/220V, NC	1
23-1	5516251	Screw, Set, M8 x10	12	72		Motor Contactor	2
24	5507613	Washer, Flat, M10	2		5713041	115/220V, 1 Phase	
25	5507614	Screw, Cap, M10 x 40	3		5713001	220/440V, 3 Phase	
25-1	5516255	Washer, Lock, M10	3	73	5713051	Transformer, 1PH/3PH	1
26	5507615	Screw, Cap, M6 x 20	2	74	5713061	Strip, Terminal	1
27	5512702	Bolt, Hex	1	75	5507651	Washer, Flat, M16	2
27-1	5507619	Nut, Hex, M10	1	76	5512708	Handle	1
28	5507616	Bracket	1	77	5712571	Bearing, Needle	2
29	5507613	Washer, Flat, M10	2	78	5507653	Screw, Cap, M6 x 12	2
30	5507614	Screw, Cap, M10 x 40	2	78-1	5516257	Washer, Lock, M6	2
30-1	5516255	Washer, Lock, M10	3	79	5507654	Plate, Guide	1
31	5512705	Nut, Sliding	2	80	5507655	Spring, Torsion	1
32	5507618	Screw, Cap, M6 x30	2	81	5712591	Shaft, Pivot	1
32-1	5516257	Washer, Lock, M6	2	82	5507607	Washer, Flat, M12	2
33	5512706	Bracket	1	83	5507658	Fitting, Brass	2
34	5507619	Nut, Hex, M10	1	85	5507660G	Bracket, Pivot	1
35	5507620	Bolt, Hex, M10 x 25	1	86	5507661	Nut, Hex, M12	1
36	5507621	Screw, Set, M8 x 16	2	87	5507607	Washer, Flat, M12	1
37	5512707G	Bracket, Mounting	1	88	5507662	Bolt, Hex, M12 x 40	1
38	TS-149105	Bolt, Hex, M10 x 35	2	89	5507663	Shaft, Torsion Spring	1
38-1	5516255	Washer, Lock, M10	2	90	5507664	C-Ring, S-22	1
38-2	5507613	Flat Washer, M10	2	91	5507665	Bolt, Cap, M8 x 25	1
39	5713111	Knob, Lock	1	91-1	5507637	Washer, Lock, M8	2
				91-2	5507668	Flat Washer, M8	2

* Not shown in exploded view

Parts List - Model J-7020M/J-7040M Miter Cut-off Saw Base

ITEM NO.	PART NO.	DESCRIPTION	QTY	ITEM NO.	PART NO.	DESCRIPTION	QTY
92	5507666	Plate, Motor Tilt	1	263-1	J-7020263-1	Screw, Pan Head, 3/16" x 1/4"	4
92-1	TS-1490041	Bolt, Hex, M8 x 25	1	264	J-7020264G	Base, Box	1
93	5507667	Plate, Limit Switch	1	265	J-5521930G	Sliding, Turn, Left	1
94	5507668	Washer, Flat, M8	2	265-1	J-7020265-1	Scale, Angle	1
95	5507669	Bolt, Hex, M8 x 10	2	265-2	TS-1505031	Screw, Cap, M10 x25	1
95-1	5507637	Washer, Lock, M8	2	266	J-7020266	Strain Relief	1
96	TS-1482011	Bolt, Hex, M6 x 10	4	267	J-7020267	Ring, Rubber	1
97	5712741	Switch, Limit	1	268	J-7020268	Ring, Rubber	1
98	5507671	Plate	2	269	5519503	Fuse, 1A	3
99	5507607	Washer, Flat, M12	2	270	5519502	Bracket, Fuse	3
100	5512711	Screw, Cap, M12 x 50	2	271	J-7020271	Bushing, 9mm	1
101	5711091	Nut, Hex, 1/2	1	272	5521936	Bushing, 3mm	1
102	5507674	Bracket, Spring	1	273	5516856G	Panel, Access	1
103	5512712	Screw, Cap, M8 x 30	2	*	5512787	Kit, Piston/Seal	1
103-1	5507668	Flat Washer, M8	2	*	5713371A	E-M Valve & Coil	1
103-2	5507637	Washer, Lock, M8	2				
104	5711091	Nut, Hex, 1/2	1				
105	5507675	C-Bolt, Adjustable	1				
106	5507676	Spring	1				
107	5507677	Vise, Left Jaw	1				
108	5512713	Bolt, Hex, M12 x 35	1				
109	5512714	Screw, Clamping	1				
110	5507678	Washer, Lock, M12	1				
111	5507679	Pin, Pivot	1				
112	5507680	Vise, Fixed Jaw	1				
113	5512715	Bolt, Hex, M12 x 40	1				
113-1	5507607	Flat Washer, M12	3				
114	5507678	Washer, Lock, M12	5				
115	5713231	Swivel Bushing	1				
115-1		C-Ring, S-32	1				
116	5507682	Screw, Cap	2				
117	5507683	Box, Stationary	1				
117-1	TS-1490021	Bolt, Hex, M8 x 16	4				
117-2	5507637	Washer, Lock, M8	4				
117-3	5507668	Flat Washer, M8	4				
118	5713271	Screw, Cap, 1/4 x 3/4	2				
119	J-5713261G	Column, Control	1				
120	5713281	Swivel	1				
120-1	TS-0050021	Screw, Cap, 1/4" x 5/8"	1				
120-2	5519510	Nut, Hex, 1/4"	1				
121	5507686	Cylinder, Hydraulic	1				
122	5507687	Washer, Lock, M10	3				
123	5512718	Bolt, Hex, M10 x 30	3				
124	J-5507688	Plate, Hydraulic Mtg.	1				
125	5507689	Pin, Cotter	1				
126	J-5713291G	Box, Control	1				
127	5713311	Panel, Control	1				
128	5713321	Screw, Slotted, 3/16 x 1/4	6				
129	5713331	Lamp, Electric Pwr on	1				
130	5713341	Switch, Start	1				
131	5713351	Switch, Stop	1				
132	5713361	Switch, Down	1				
133	5516855	Switch, Pump, Coolant	1				
134		Panel, Elect., Complete	1				
	5514613	3-Phase					
	5514616	1-Phase					
135	5713371	E-M Valve Complete	1				
263	J-7020263G	Cover, Box	1				

* Not shown in exploded view

Parts List - Model J-7020M/J-7040M Miter Cut-off Saw Head

ITEM NO.	PART NO.	DESCRIPTION	QTY	ITEM NO.	PART NO.	DESCRIPTION	QTY
145	5713381	Screw, 1/4 x 3/8	2		5519683M	Model 7040, 2HP, 3P	
146	J-5507697G	Cover, Blade Wheel	1	177-2	TS-1490081	Bolt, Hex, M8 x 45	4
146-1	5518109	Label, JET Logo	1	177-3	5507637	Washer, Lock, M8	4
146-2	5519511	Label, Blade Size	1	177-4	5507668	Washer, M8	8
146-3	5519513	Label, Glasses	1	177-5	5516239	Nut, Hex, M8	4
146-4	5519512	Label, Warning	1	178	5713741	Bolt, 1/2 x 3/4	1
147	5713411	Guard, Wire Brush	1	180	5513733	Key, 7 x 7 x 40	1
147-1	5519514	Label, Saw	1	181	5713761	Washer, 1/2" I.D.	1
148	5713421	Handle	2	182	5713771	Washer, 5/16	2
149	5713431	Washer, 1/2"	1	183	5713671	Screw, Slotted, 1/4 x 3/8	6
150	J-5713831	Wheel, Drive	1	184	5713781	Screw, Cap, M16 x 30	3
150-1	5521936	Bushing, 3mm	1	185	5713791	Bolt, 1/2 x 3/4	1
151		Blade, Bi-Metal	1	186	5713811	Washer, 1/2	1
	5674011	4/6 Vari Tooth		187	BB-6205Z	Bearing 6205Z	2
	5674021	6/10 Vari Tooth		188	J-5713441	Wheel, Idler	1
152	5713461	Hose	1	189	J-5713841	Guard, Blade	1
152-1	5519515	Clamp, Hose	1	189-1	TS-1490021	Bolt, Hex, M8 x16	1
153	5713471	Bolt, 3/8 x 1-1/4	4	189-2	5507637	Washer, Lock, M8	1
154	5713481	Washer, Spring, 3/8	4	189-3	5507668	Washer, M8	1
155	5713491	Bolt, 1/2 x 1-1/4	4	190	5713851	Left Blade Guide Brkt.	1
156	5713511	Bolt, 5/16 x 1/2	2	190A	5713851A	Right Blade Guide Brkt.	1
157	5713521	Screw, 1/4 x 5/8	4	190-1		Screw, Cap, 1/2" x 3/8"	4
157-1	5713661	Washer, 1/4	4	190-2	5628371	Washer, Lock, 1/2"	4
158	J-5507709G	Box, Blade Wheel	1	190-3	5507607	Washer, 1/2"	4
158-1		Label, ID	1	190-4	5519684	Tube, Copper	2
158-2	5519672	Label, Tension	1	190-5	TS-0270051	Screw, Set, 5/16" x 1/2"	6
158-3	5519696	Stopper, Arm	1	191	5717138	Assy., Eccentric Shaft	2
158-4	5711091	Nut, Hex, 1/2"	1	191A	5717142	Assy., Center Shaft	2
159	5713541G	Seat, Support Bracket	1	192	5713871	Guide, Blade, Tun. Carb.	4
159-1	TS-0070051	Bolt, Hex, 1/2" x 2"	1	192-1	5713661	Washer, 1/4"	8
159-2	5711091	Nut, Hex, 1/2"	1	192-2	5713651	Washer, Lock, 1/4"	4
160	J-5507711	Gearbox Assembly	1	192-3	5519508	Screw, Cap, 1/4" x 1"	4
160-1	5519675	Key, 7 x 7 x 40	1	193	5713881	Block, Elevating	2
161	5513734	Key, 7 x 7 x 65	1	194	5713891	Block, Active	2
162	J-5507713	Cover, Speed Change	1	195	5713911	Screw, Cap, 1/4 x 5/16	2
162-1	5510677	Label, Speed Chart	1	196	5632831	Bearing, 608ZZ	4
162-2	5519676	Knob	1	197	5713931	Washer, Spring, 5/16	4
162-3	5714041	Washer, 3/8"	1	198	5713941	Screw, Cap, 5/16 x1-3/4	4
163	5713581	Pulley, Gearbox	1	199	5713951	Washer,Lock,Black,5/16	4
164	5713591	Belt	1	200	J-5713961G	Guide Support	2
165	5713611	Pulley, Motor	1	200-1	5518423	Label, Blade Orientation	2
166	J-5507717	Plate, Speed Change	1	201	5713971	Scale, Angle	1
166-1		Bolt, Hex, M8 x16	2	202	5713981	Screw, Flat, M5 x 0.8	4
166-2	5507637	Washer, Lock, M8	2	203	5713991G	Guide Support Mount	1
166-3	5507668	Flat Washer, M8	1	204	J-5714011G	Left Bracket support	1
167	5507718G	Plate, Motor Mount	1	204-1	5712561	Screw, Pan Head, M5 x 8	4
168	5713771	Washer, 5/16	2	204-2	5519694	Clamp, Rubber	4
169	5713661	Washer, 1/4	1	205	5714021	Screw, 1/2 x 1	4
170	5713651	Washer Lock 1/4	2	205-1	5507607	Washer, 1/2"	2
171	5713661	Washer, 1/4	2	206	5714031	Knob	2
172	5714291	Valve, Relief	1	207	5714041	Washer, 3/8	2
173	5628371	Washer, Spring, 1/2	4	208	5714051	Block, Locking	2
174	5713691	Washer, Black, 5/16	4	209	5714061	Screw, 5/16 x 1/2	4
175	5713711	Screw, Cap, 3/8 x 1	2	210	J-5714071G	Right Bracket support	1
176	5713721	Screw, Cap, 5/16 x 5/8	4	211	5714161	Bolt, 1/4 x 1/2	1
177		Motor	1	212	5713651	Washer, Spring, 1/4	1
	J-5713731M	Model 7020, 1HP, 1P		213	5714111	Brush, Wire	1
	J-5713732M	Model 7040, 2HP, 3P		214	5714121	Seat, Steel Brush	1
177-1		Label, Motor	1	215	5713771	Washer, 5/16	2
	5519682M	Model 7020, 1HP, 1P		216	5714141	Clamp, Hose	2

Parts List - Model J-7020M/J-7040M Miter Cut-off Saw Head

ITEM NO.	PART NO.	DESCRIPTION	QTY	ITEM NO.	PART NO.	DESCRIPTION	QTY
217	5713651	Washer, Spring, 1/4	4	261-1	5714041	Washer, 3/8"	1
218	5714161	Bolt, 1/4 x 1/2	4	261-2	5713081	Nut, Hex, 3/8"	1
219	5628371	Washer, Spring, 1/2	4	262	5714311	Connection, Head	1
220	5714181G	Gib	2				
221	5714191	Screw, Cap, 1/2 x 3/4	1				
222	5714211	Screw, Cap, M8 x 20	4				
222-1	5507668	Washer, M8	4				
224	5714221	Knob	4				
225	5714231	Nozzle, Flexible	1				
225-1	5507607	Clamp, Hose	4				
226	5714241	Shaft, Blade Wheel	1				
226-1	5519691	Scale, Tension	1				
226-2	5519690	Screw, Pan Head, M6 x 12	2				
227	5714251	Threaded Nut	1				
228	5714261	Screw, Set, 5/16 x 1/2	1				
229	5714271G	Bracket, Slide	1				
230	5714281	Washer	1				
231	5507788	Shaft, Support	1				
231-1		C-Ring, S-19	1				
232	J-5507785G	Bracket, Motor Mount	1				
232-1	TS-1492021	Bolt, Hex, M12 x 30	2				
233	5507790	Bearing (51104NJK)	1				
234	5507791	Washer	1				
235	5508005	Nut, Hex	1				
238	5714331	Handle, Blade Cover	1				
239	5711091	Nut, Hex, 1/2	1				
240	5714351	Washer, 3/4	1				
241	5714361	Washer, Special Spring	13				
242	5714371	Wheel, Hand	1				
243	J-5714381G	Bracket, Slide	1				
244	5714391	Shaft, Tension	1				
244-1	5519692	Nut, Hex	1				
244-2	5519693	Screw, Set, M6 x8	1				
245	5714411	Key, Square, 5MM	1				
246	5714421	Bolt, 3/8 x 2-1/2	3				
246-1	5713481	Washer, Lock, M10	3				
247	J-5714431G	Seat, Oil Pressure	1				
247-1	TS-1490021	Bolt, Hex, M8 x 16	2				
247-2	5507637	Washer, Lock, M8	2				
247-3	5507668	Washer, M8	2				
248	J-5714441G	Plate, Cover	1				
249	5714451	Screw, Slotted, 5/16x5/8	2				
250	5714461	Panel, Control	1				
251	5714471	Screw, Slotted, 1/4x3/8	2				
252	5713941	Screw, Cap, 5/16x1-3/4	4				
253	5712881	Washer, Lock, 1/2	4				
254	5517141	Bushing, Eccentric	2				
255	5517140	Bushing, Center	2				
256	5713861	Bearing, Ball, 6201ZZ	8				
257	5713761	Washer, 1/2	4				
258	5519492	Rivet, 2mm	9				
259	TS-1525031	Screw, Set, M10 x 16	2				
260	5519679	Bracket	1				
260-1	5713381	Bolt, Hex, 1/4" x 3/8"	2				
260-2	5713651	Washer, Lock, 1/4"	2				
260-3	5713661	Washer, 1/4"	2				
261	5519678	Rod	1				



427 New Sanford Road
LaVergne, Tennessee 37086
Ph.: 800-274-6848
www.jettools.com