



# Operating Instructions and Parts Manual

## 8x12-inch Gear Head Horizontal Band Saw

### Model HBS-812G



**JET**  
427 New Sanford Road  
LaVergne, Tennessee 37086  
Ph.: 800-274-6848  
[www.jettools.com](http://www.jettools.com)

**Part No. M-413460**  
Revision C1 07/2017  
Copyright © 2017 JET

# 1.0 Warranty and Service

JET warrants every product it sells against manufacturers' defects. If one of our tools needs service or repair, please contact Technical Service by calling 1-800-274-6846, 8AM to 5PM CST, Monday through Friday.

## Warranty Period

The general warranty lasts for the time period specified in the literature included with your product or on the official JET branded website.

- JET products carry a limited warranty which varies in duration based upon the product. (See chart below)
- Accessories carry a limited warranty of one year from the date of receipt.
- Consumable items are defined as expendable parts or accessories expected to become inoperable within a reasonable amount of use and are covered by a 90 day limited warranty against manufacturer's defects.

## Who is Covered

This warranty covers only the initial purchaser of the product from the date of delivery.

## What is Covered

This warranty covers any defects in workmanship or materials subject to the limitations stated below. This warranty does not cover failures due directly or indirectly to misuse, abuse, negligence or accidents, normal wear-and-tear, improper repair, alterations or lack of maintenance. JET woodworking machinery is designed to be used with Wood. Use of these machines in the processing of metal, plastics, or other materials outside recommended guidelines may void the warranty. The exceptions are acrylics and other natural items that are made specifically for wood turning.

## Warranty Limitations

Woodworking products with a Five Year Warranty that are used for commercial or industrial purposes default to a Two Year Warranty. Please contact Technical Service at 1-800-274-6846 for further clarification.

## How to Get Technical Support

Please contact Technical Service by calling 1-800-274-6846. **Please note that you will be asked to provide proof of initial purchase when calling.** If a product requires further inspection, the Technical Service representative will explain and assist with any additional action needed. JET has Authorized Service Centers located throughout the United States. For the name of an Authorized Service Center in your area call 1-800-274-6846 or use the Service Center Locator on the JET website.

## More Information

JET is constantly adding new products. For complete, up-to-date product information, check with your local distributor or visit the JET website.

## How State Law Applies

This warranty gives you specific legal rights, subject to applicable state law.

## Limitations on This Warranty

JET LIMITS ALL IMPLIED WARRANTIES TO THE PERIOD OF THE LIMITED WARRANTY FOR EACH PRODUCT. EXCEPT AS STATED HEREIN, ANY IMPLIED WARRANTIES OF MERCHANTABILITY AND FITNESS FOR A PARTICULAR PURPOSE ARE EXCLUDED. SOME STATES DO NOT ALLOW LIMITATIONS ON HOW LONG AN IMPLIED WARRANTY LASTS, SO THE ABOVE LIMITATION MAY NOT APPLY TO YOU.

JET SHALL IN NO EVENT BE LIABLE FOR DEATH, INJURIES TO PERSONS OR PROPERTY, OR FOR INCIDENTAL, CONTINGENT, SPECIAL, OR CONSEQUENTIAL DAMAGES ARISING FROM THE USE OF OUR PRODUCTS. SOME STATES DO NOT ALLOW THE EXCLUSION OR LIMITATION OF INCIDENTAL OR CONSEQUENTIAL DAMAGES, SO THE ABOVE LIMITATION OR EXCLUSION MAY NOT APPLY TO YOU.

JET sells through distributors only. The specifications listed in JET printed materials and on official JET website are given as general information and are not binding. JET reserves the right to effect at any time, without prior notice, those alterations to parts, fittings, and accessory equipment which they may deem necessary for any reason whatsoever. JET® branded products are not sold in Canada by JPW Industries, Inc.

## Product Listing with Warranty Period

90 Days – Parts; Consumable items
1 Year – Motors; Machine Accessories
2 Year – Metalworking Machinery; Electric Hoists, Electric Hoist Accessories; Woodworking Machinery used for industrial or commercial purposes
5 Year – Woodworking Machinery
Limited Lifetime – JET Parallel clamps; VOLT Series Electric Hoists; Manual Hoists; Manual Hoist Accessories; Shop Tools; Warehouse & Dock products; Hand Tools; Air Tools

NOTE: JET is a division of JPW Industries, Inc. References in this document to JET also apply to JPW Industries, Inc., or any of its successors in interest to the JET brand.

## 2.0 Table of Contents

Section	Page
1.0 Warranty and Service.....	2
2.0 Table of Contents.....	3
3.0 Safety Warnings.....	4
4.0 About this manual .....	5
5.0 Features .....	6
6.0 Specifications.....	6
7.0 Set-Up and Assembly .....	8
7.1 Unpacking and cleanup.....	8
7.2 Shipping contents.....	8
7.3 Assembly.....	9
7.4 Vertical cutting plate .....	9
7.5 Coolant system.....	10
8.0 Electrical connections .....	11
8.1 Grounding instructions .....	11
8.2 Voltage conversion.....	11
8.3 Extension cords.....	12
9.0 Adjustments .....	12
9.1 Squaring blade to table .....	12
9.2 Squaring blade to vise.....	12
9.3 Vise positioning .....	13
9.4 Setting feed rate .....	13
9.5 Counterbalance spring .....	14
9.6 Blade installation/replacement .....	14
9.7 Blade tension.....	15
9.8 Blade tracking.....	15
9.9 Test cutting to verify adjustment.....	16
9.10 Blade speed .....	16
9.11 Blade guide adjustment.....	17
9.12 Chip brush .....	17
9.13 On/off switch.....	17
10.0 Operating controls.....	18
11.0 Operation .....	18
11.1 Pre-Operation inspection.....	18
11.2 Blade break-in procedure .....	18
11.3 General operating procedure .....	18
11.4 Evaluating cutting efficiency .....	19
12.0 Maintenance.....	19
12.1 Coolant level.....	19
12.2 Gear box.....	19
13.0 Troubleshooting the HBS-812G .....	20
14.0 Replacement Parts.....	21
14.1.1 HBS-812G Table and Stand Assembly – Exploded View .....	22
14.1.2 HBS-812G Bow Assembly – Exploded View.....	23
14.1.3 HBS-812G Table, Bow, Stand Assemblies – Parts List .....	24
14.2.1 HBS-812G Gearbox Assembly – Exploded View.....	28
14.2.2 HBS-812G Gearbox Assembly – Parts List.....	29
15.0 Electrical Connections for HBS-812G .....	30



### 3.0 Safety Warnings

1. Read and understand the entire owner's manual before attempting assembly or operation.
2. Read and understand the warnings posted on the machine and in this manual. Failure to comply with all of these warnings may cause serious injury.
3. Replace the warning labels if they become obscured or removed.
4. This band saw is designed and intended for use by properly trained and experienced personnel only. If you are not familiar with the proper and safe operation of a band saw, do not use until proper training and knowledge have been obtained.
5. Do not use this band saw for other than its intended use. If used for other purposes, JET disclaims any real or implied warranty and holds itself harmless from any injury that may result from that use.
6. Always wear ANSI approved safety glasses/face shields while using this band saw. *Everyday eyeglasses only have impact resistant lenses; they are not safety glasses.*
7. Before operating this machine, remove tie, rings, watches and other jewelry, and roll sleeves up past the elbows. Remove all loose clothing and confine long hair. Non-slip footwear or anti-skid floor strips are recommended.
8. Wear ear protectors (plugs or muffs) during extended periods of operation.
9. CALIFORNIA PROPOSITION 65 WARNING: This product contains chemicals known to the State of California to cause cancer, or birth defects or other reproductive harm.
10. This product, when used for welding, cutting, or working with metal, produces fumes, gases, or dusts which contain chemicals known to the State of California to cause birth defects and, in some cases, cancer. (California Health and Safety Code Section 25249.5 et seq.)
11. Do not operate this machine while tired or under the influence of drugs, alcohol or any medication.
12. Make certain the switch is in the **OFF** position before connecting the machine to the power supply.
13. Make certain the machine is properly grounded.
14. Make all machine adjustments or maintenance with the machine unplugged from the power source.
15. Remove adjusting keys and wrenches. Form a habit of checking to see that keys and adjusting wrenches are removed from the machine before turning it on.
16. Keep safety guards in place at all times when the machine is in use. If removed for maintenance purposes, use extreme caution and replace the guards immediately after maintenance is complete.
17. Make sure workpiece is securely clamped in the vise. Never use your hand to hold the workpiece.
18. Check coolant level frequently. Replace dirty or weak coolant.
19. Check damaged parts. Before further use of the machine, a guard or other part that is damaged should be carefully checked to determine that it will operate properly and perform its intended function. Check for alignment of moving parts, binding of moving parts, breakage of parts, mounting and any other conditions that may affect its operation. A guard or other part that is damaged should be properly repaired or replaced.
20. Inspect blade for cracks, wear or missing teeth. Replace blade if these symptoms are found.
21. Provide for adequate space surrounding work area and non-glare, overhead lighting.
22. Keep the floor around the machine clean and free of scrap material, oil and grease.
23. Keep visitors a safe distance from the work area. **Keep children away.**
24. Make your workshop child proof with padlocks, master switches or by removing starter keys.
25. Give your work undivided attention. Looking around, carrying on a conversation and "horse-play" are careless acts that can result in serious injury.
26. Maintain a balanced stance at all times so that you do not fall or lean against the blade or other moving parts. Do not overreach or use excessive force to perform any machine operation.
27. Use the right tool at the correct speed and feed rate. Do not force a tool or attachment to do a job for which it was not designed. The right tool will do the job better and more safely.
28. Use recommended accessories; improper accessories may be hazardous.

29. Maintain tools with care. Keep blades sharp and clean for the best and safest performance. Follow instructions for lubricating and changing accessories.
30. Turn off the machine and disconnect from power before cleaning. Use a brush to remove chips or swarf — do not use your hands.
31. Do not stand on the machine. Serious injury could occur if the machine tips over.
32. Never leave the machine running unattended. Turn the power off and do not leave the machine until it comes to a complete stop.
33. Remove loose items and unnecessary work pieces from the area before starting the machine.

Familiarize yourself with the following safety notices used in this manual:

**⚠ CAUTION** This means that if precautions are not heeded, it may result in minor injury and/or possible machine damage.

**⚠ WARNING** This means that if precautions are not heeded, it may result in serious or even fatal injury.

## 4.0 About this manual

This manual is provided by JET covering the safe operation and maintenance procedures for a JET Model HBS-812G Band Saw. This manual contains instructions on installation, safety precautions, general operating procedures, maintenance instructions and parts breakdown. Your machine has been designed and constructed to provide years of trouble-free operation if used in accordance with the instructions set forth in this document.

This manual is not intended to be an exhaustive guide to band saw operations, stock selection, etc. Consult a machinery handbook and/or experienced users for additional information. Whatever accepted methods or materials are used, always make personal safety a priority.

If there are questions or comments, please contact your local supplier or JET. JET can also be reached at our web site: [www.jettools.com](http://www.jettools.com).

Retain this manual for future reference. If the machine transfers ownership, the manual should accompany it.

## 5.0 Features

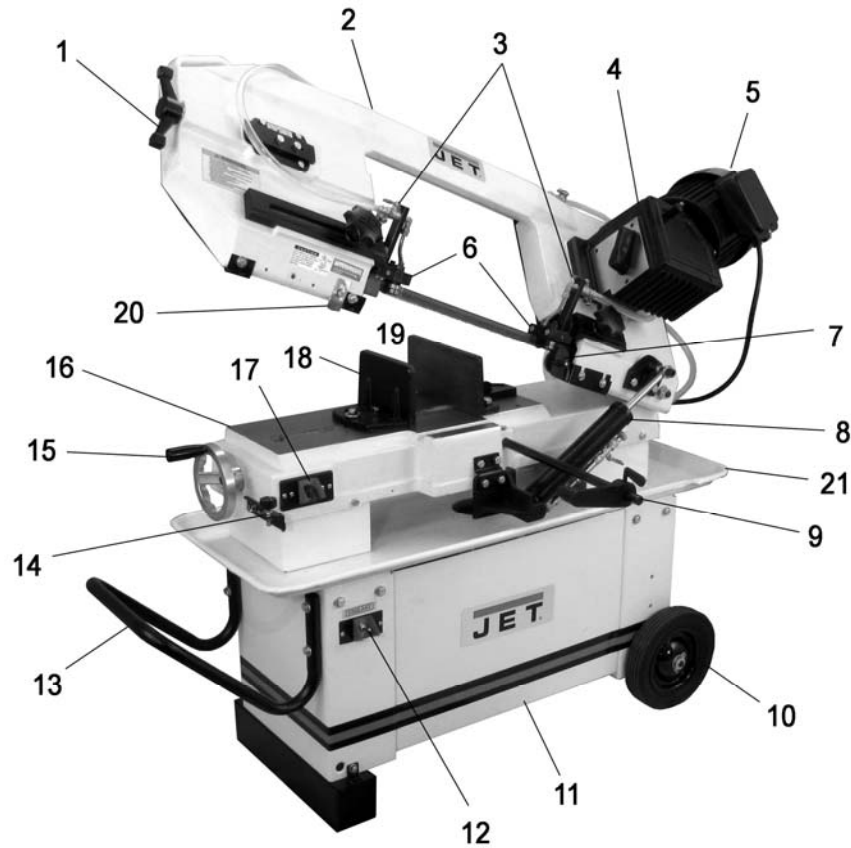

Figure 1

- |  |                                    |
|--|------------------------------------|
| 1. Blade tension handle                    | 12. Coolant toggle switch          |
| 2. Cast iron bow                           | 13. Handle                         |
| 3. Coolant taps                            | 14. Bow stop screw                 |
| 4. 3-speed gearbox                         | 15. Vise handwheel                 |
| 5. 1HP motor                               | 16. Cast iron table                |
| 6. Ball bearing blade guides               | 17. On/off toggle switch           |
| 7. Chip brush                              | 18. Floating vise jaw (adjustable) |
| 8. Hydraulic cylinder with regulator valve | 19. Fixed vise jaw (adjustable)    |
| 9. Adjustable work stop                    | 20. Shut-off tab                   |
| 10. Rubber tires                           | 21. Drain pan                      |
| 11. Steel stand with coolant tank          |                                    |

## 6.0 Specifications

Model Number.....HBS-812G  
 Stock Number ..... 413460

### Materials:

Frame ..... cast iron  
 Table..... cast iron  
 Band wheels ..... cast iron  
 Stand ..... steel  
 Blade included .....bi-metal, variable tooth  
 Blade guides ..... ball bearing  
 Tires..... rubber

Capacities:

Vise adjustment angle .....	0 to 45 deg.
Round capacity at 90° .....	8" (203 mm)
Round capacity at 45° .....	5" (127 mm)
Rectangle capacity at 90° (W x H) .....	8" x 11-1/4" (203 x 286 mm)
Rectangle capacity at 45° (W x H) .....	5" x 8" (127 x 203 mm)
Gearbox capacity .....	0.3L (10.14 oz)
Coolant tank capacity .....	9L (2.25 gal)

Motor and Electricals:

Motor type (UL Listed) .....	totally enclosed fan cooled, induction
Horsepower .....	1 HP (0.75 kW)
Phase .....	single
Voltage .....	115/230 V (prewired 115V)
Cycle .....	60Hz
Listed FLA (full load amps) .....	10/5 A
Starting amps .....	28A
Running amps (no load) .....	6.2A
Power transfer .....	gearbox
Control switch .....	toggle
Motor speed .....	1720 rpm
Blade speeds .....	145, 200, 245 fpm
Power cord length .....	6 feet (180 cm)
Power cord type .....	16AWGx3c
Power plug installed .....	yes
Recommended circuit size <sup>1</sup> .....	15 A
Noise emission:	
without load .....	70 dB at 60 inches from blade
with load .....	75 dB at 60 inches from blade

Coolant pump:

Horsepower .....	1/8 HP
Phase .....	single
Voltage .....	115/230 V
Cycle .....	60Hz
Listed FLA (full load amps) .....	0.5/0.25 A
Control switch .....	toggle

Weights:

Net Weight .....	308 lb (140 kg)
Shipping Weight .....	364 lb (165 kg)

Dimensions:

Blade .....	3/4"W x 0.032"T x 93"L (19 x 0.9 x 2360 mm)
Blade wheel diameter .....	11-1/2" (292mm)
Vise jaw height .....	4" (102 mm)
Vise jaw depth .....	8-1/2" (216 mm)
Table size (LxW) .....	21" x 7" (533 x 178 mm)
Table height from floor .....	24" (609.6 mm)
Tire diameter .....	8" (203 mm)
Overall assembled, horizontal position .....	48"L x 22"W x 42"H (1219 x 559 x 1067 mm)
Overall assembled, vertical position .....	60"L x 22"W x 66"H (1524 x 559 x 1676 mm)

Other:

Blade tension range .....	22000-25000 lb/in <sup>2</sup> (1550-1760 kg/cm <sup>2</sup> )
---------------------------	--

<sup>1</sup> subject to local and national electrical codes.

The specifications in this manual were current at time of publication, but because of our policy of continuous improvement, JET reserves the right to change specifications at any time and without prior notice, without incurring obligations.

## 7.0 Set-Up and Assembly

### 7.1 Unpacking and cleanup

Inspect contents of shipping container for shipping damage. Report any damage to your distributor.

Remove all contents from carton, and compare to the contents list in this manual. Report any part shortages to your distributor. Do not discard carton or packing material until machine is assembled and running satisfactorily.

Exposed metal areas have a rust preventative applied. Remove this with a soft rag and solvent or degreaser. Do not use cellulose-based solvents such as paint thinner or lacquer thinner; these will damage painted and plastic surfaces.

### 7.2 Shipping contents

If you do not see a part below, check the machine; some parts may have come pre-assembled to the saw.

Refer to Figures 2 and 3.

- 1 Band Saw
- 1 Workstop – **A**
- 1 Workstop rod – **B**
- 1 Filter screen – **C**
- 1 Vertical cutting plate – **D**
- 1 Handle – **E**
- 1 Axle – **F**
- 2 Wheels – **G**
- 1 Foot stand – **H**
- 1 Instructions and Parts Manual (not shown)
- 1 Warranty Card (not shown)

Hardware Package (p/n *HBS812G-HP*):

- 2 Hex cap screws 1/4"x3/4" – **HP-1**
- 2 Lock washers 1/4" – **HP-2**
- 2 Flat washers 1/4" – **HP-3**
- 4 Hex cap screws 5/16"x1-1/2" – **HP-4**
- 4 Lock washers 5/16" – **HP-5**
- 4 Flat washers 5/16" – **HP-6**
- 4 Hex nuts 5/16" – **HP-7**
- 2 Cotter pins – **HP-8**
- 2 Flat washers 1/2" – **HP-9**

#### **Tools required for assembly:**

- (2) 12mm wrenches
- 10mm wrench
- Pliers

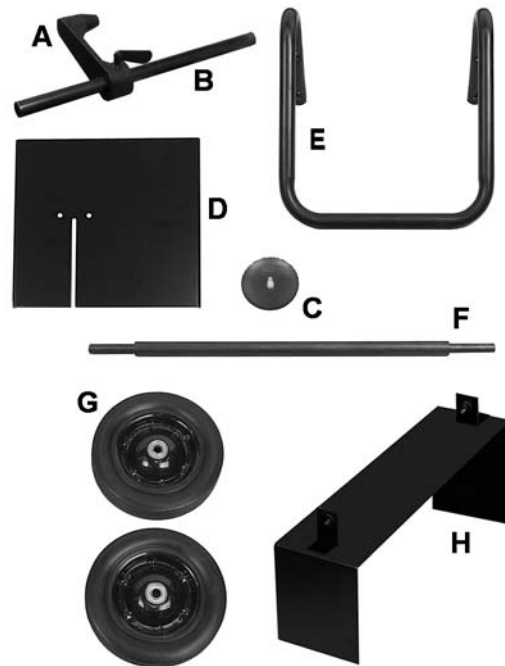

Figure 2

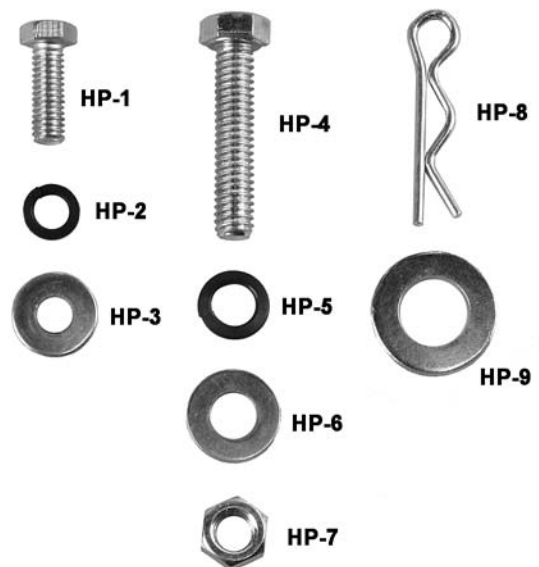

Figure 3  
Hardware package *HBS812G-HP*

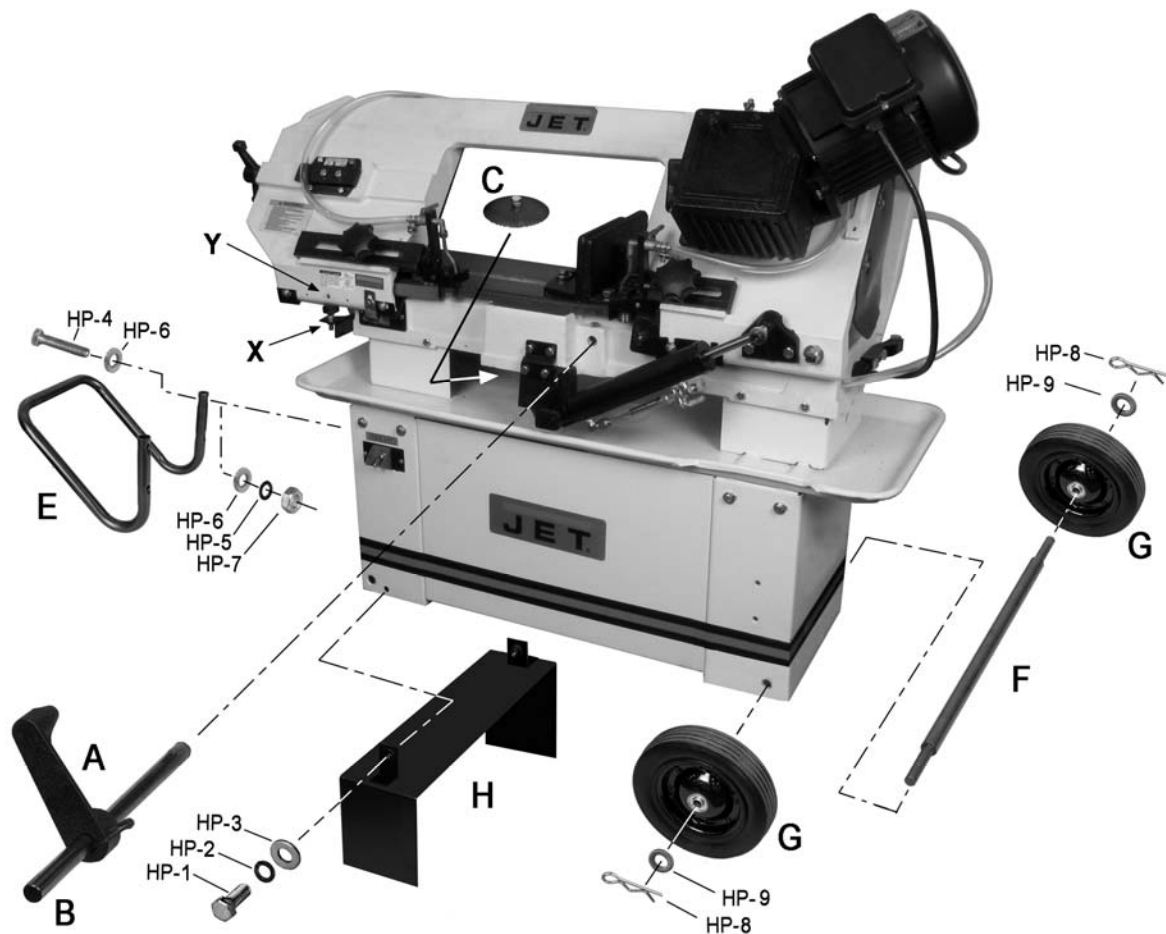

Figure 4

### 7.3 Assembly

Refer to Figure 4.

**WARNING** Band Saw should be disconnected from electrical power during assembly and setup.

1. Remove brackets holding saw to pallet.
2. Use properly rated lifting equipment (hoist or forklift) with straps placed beneath cast iron portion of saw.
3. Use blocking beneath saw, and install foot stand (H). Secure with four screws and washers (HP-1/2/3).
4. Install axle and wheels (F/G). Install cotter pin (HP-8) through hole in axle, and bend back legs of cotter pin to secure each wheel.
5. Slide workstop rod (B) into hole on saw base and slide workstop (A) onto rod. (NOTE: Do not insert rod too far so that it hits the vise leadscrew).
6. Install handle (E), and place filter screen (C) over coolant drain hole in pan.

7. Remove stop bolt (X, Figure 4) and remove shipping bracket (Y). Retain bracket in case you must transport the machine in the future. **Reinstall stop bolt.**

**CAUTION** After removal of shipping bracket (Y), the stop bolt (X) must be reinstalled and properly adjusted to prevent damage to the on/off switch.

### 7.4 Vertical cutting plate

These steps are only necessary when using band saw in vertical position.

1. Disconnect machine from power source.
2. Raise bow to vertical position.
3. Remove two screws and remove seat plate, as shown in Figure 5.

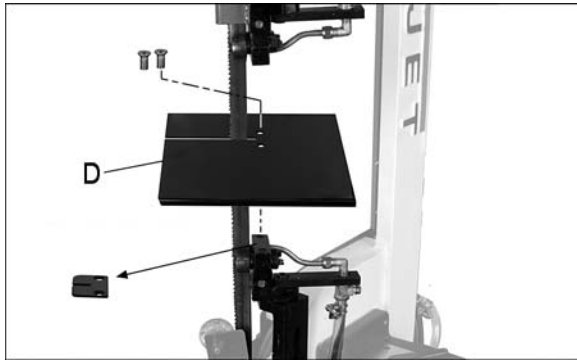

Figure 5

4. Guide blade through slot in vertical cutting plate (D, Figure 5), and tighten with the two screws.
5. Verify that vertical cutting plate is square to blade, using a machinist's square on the plate and against the blade (Figure 6).

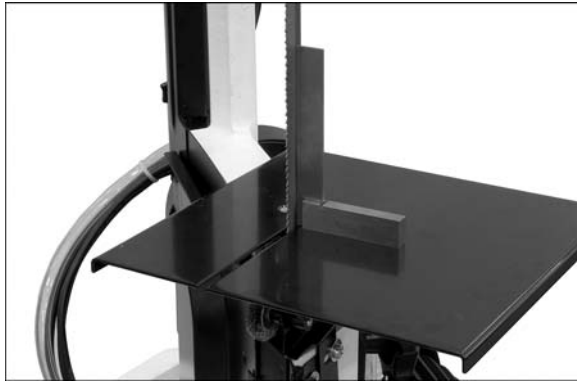

Figure 6

6. If adjustment is needed, loosen screws and place shims where required. Tighten screws.
7. Place a level on vertical cutting plate (Figure 7).



Figure 7

8. Turn stop screw (J, Figure 8) as needed, until cutting plate is level. Tighten hex nut.
9. Close valve on cylinder (lever perpendicular to cylinder) to secure bow in position.

Reinstall seat plate before using bow in horizontal position.

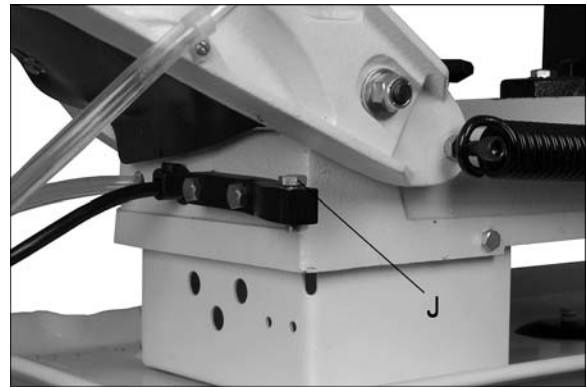

Figure 8

## 7.5 Coolant system

**CAUTION** Make sure there is coolant in the tank before operating, to prevent damage to pump.

Use of a water-soluble coolant will increase cutting efficiency and prolong blade life. Do not use black cutting oil as a substitute.

1. Remove coolant return hose (A, Figure 9) from filter cup, and slide tank out of saw base.
2. Fill tank to approximately 80% of capacity. Full capacity is 9 liters (2.25 gal).
3. Place tank into base. Place coolant return hose into the filter cup. Verify that opposite end of coolant return hose is connected to the coolant pan.
4. The coolant supply hose (B, Figure 9) should connect to the taps on the blade guide assemblies.

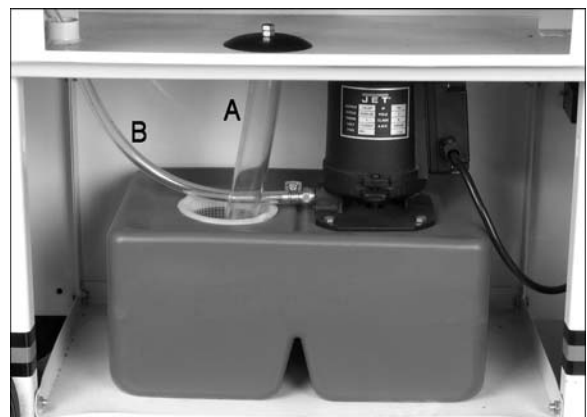

Figure 9

## 8.0 Electrical connections

**⚠WARNING** Electrical connections must be made by a qualified electrician in compliance with all relevant codes. This machine must be properly grounded to help prevent electrical shock and possible fatal injury.

The HBS-812G Band Saw is rated at 115/230V power, and pre-wired for 115 volt. The band saw comes with a plug designed for use on a circuit with a *grounded outlet* that looks like the one pictured in **A**, Figure 10.

Before connecting to power source, be sure switch is in *off* position.

It is recommended that the band saw be connected to a dedicated 15 amp circuit with a 15 amp circuit breaker or time-delay fuse. **Local codes take precedence over recommendations.**

### 8.1 Grounding instructions

#### 1. All Grounded, Cord-connected Tools:

This machine must be grounded. In the event of a malfunction or breakdown, grounding provides a path of least resistance for electric current to reduce the risk of electric shock. This tool is equipped with an electric cord having an equipment-grounding conductor and a grounding plug. The plug must be plugged into a matching outlet that is properly installed and grounded in accordance with all local codes and ordinances.

Do not modify the plug provided - if it will not fit the outlet, have the proper outlet installed by a qualified electrician.

Improper connection of the equipment-grounding conductor can result in a risk of electric shock. The conductor with insulation having an outer surface that is green with or without yellow stripes is the equipment-grounding conductor. If repair or replacement of the electric cord or plug is necessary, do not connect the equipment-grounding conductor to a live terminal.

**⚠WARNING** Check with a qualified electrician or service personnel if the grounding instructions are not completely understood, or if in doubt as to whether the tool is properly grounded. Failure to comply may cause serious or fatal injury.

Use only 3-wire extension cords that have 3-prong grounding plugs and 3-pole receptacles that accept the tool's plug.

Repair or replace damaged or worn cord immediately.

2. *Grounded, cord-connected tools intended for use on a supply circuit having a nominal rating less than 150 volts:*

This tool is intended for use on a circuit that has an outlet that looks like the one illustrated in **A**, Figure 10. An adapter, shown in **B** and **C**, may be used to connect this plug to a 2-pole receptacle as shown in **B** if a properly grounded outlet is not available. The temporary adapter should be used only until a properly grounded outlet can be installed by a qualified electrician. *This adapter is not permitted in Canada.* The green-colored rigid ear, lug, and the like, extending from the adapter must be connected to a permanent ground such as a properly grounded outlet box.

3. *Grounded, cord-connected tools intended for use on a supply circuit having a nominal rating between 150 - 250 volts, inclusive:*

This tool is intended for use on a circuit that has an outlet that looks like the one illustrated in **D**, Figure 10. The tool has a grounding plug that looks like the plug illustrated in **D**. Make sure the tool is connected to an outlet having the same configuration as the plug. No adapter is available or should be used with this tool. If the tool must be reconnected for use on a different type of electric circuit, the reconnection should be made by qualified service personnel; and after reconnection, the tool should comply with all local codes and ordinances.

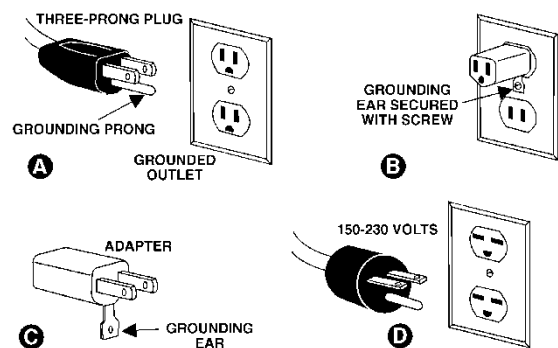

Figure 10

### 8.2 Voltage conversion

1. To switch the incoming power leads for 230 volt operation, follow the wiring diagram on the inside cover of motor junction box. Similar diagrams are shown in Figures 11/12.
2. Change the wiring inside the junction box of the coolant pump, according to the diagram found there.
3. The plug on the end of the motor cord must be replaced with a UL/CSA listed plug rated for 230V.

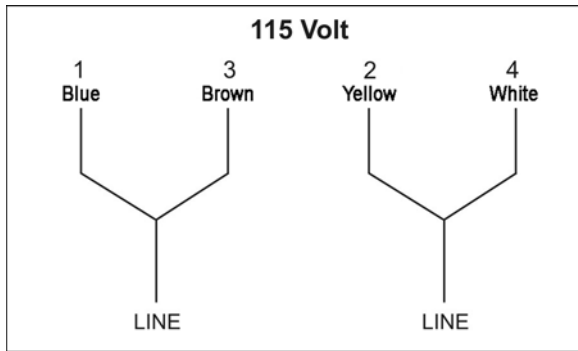

Figure 11

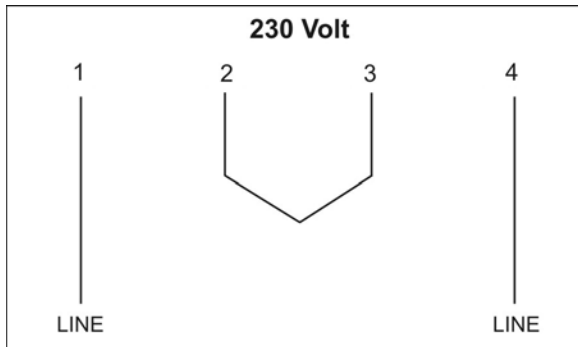

Figure 12

### 8.3 Extension cords

The use of extension cords is discouraged; try to position equipment near the power source. If an extension cord becomes necessary, make sure the cord rating is suitable for the amperage listed on the machine's motor plate. An undersized cord will cause a drop in line voltage resulting in loss of power and overheating.

Use Table 1 as a general guide in choosing the correct size cord. If in doubt, use the next heavier gauge. The smaller the gauge number, the heavier the cord.

Ampere Rating		Volts	Total length of cord in feet			
More Than	Not More Than		25	50	100	150
		120	25	50	100	150
		240	50	100	200	300
			AWG			
0	6		18	16	16	14
6	10		18	16	14	12
10	12		16	16	14	12
12	16		14	12	Not Recommended	

Extension Cord Recommendations  
Table 1

## 9.0 Adjustments

The settings on your band saw, such as blade squareness and tracking, were carefully performed by the manufacturer. You should, however, verify these before operating, in case misalignment has occurred during shipping.

### 9.1 Squaring blade to table

1. Disconnect machine from power source.
2. Place machinist's square (A, Figure 13) on table and against blade.
3. Check to see that blade contacts the square along entire width of blade.
4. If adjustment is needed, loosen screws (B, Figure 13) and rotate blade guide assemblies until blade makes contact with square along its entire width.
5. Tighten screws (B).

NOTE: If adjustment of squaring blade to table was necessary, re-verify all other blade adjustments.

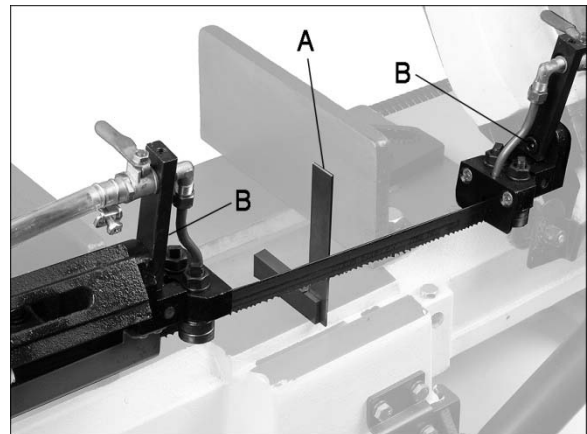

Figure 13

### 9.2 Squaring blade to vise

1. Disconnect machine from power source.
2. Place a machinist's square (A, Figure 14) on the bed against the blade and the fixed vise jaw. The square should lie along entire length of jaw and blade without a gap.
3. If adjustment is necessary, loosen screws holding vise (C, Figure 14) and shift vise until it aligns with square.
4. Retighten screws.

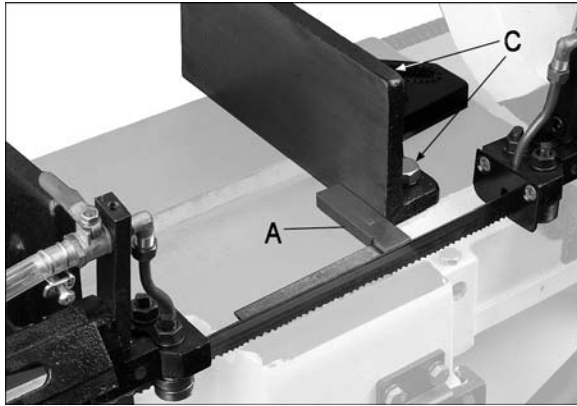

Figure 14

## 9.3 Vise positioning

### 9.3.1 90-degree cut

**WARNING** Keep hands away from blade while adjusting vise. Do not make any adjustments to vise while the machine is running.

1. Make sure fixed jaw (D, Figure 15) has been squared (section 9.2, Squaring blade to vise).
2. Position workpiece against fixed jaw.
3. Loosen screws (E) on floating jaw, and use handwheel (F) to bring floating jaw into contact with workpiece, allowing it to conform to the shape.
4. Tighten screws (E).
5. Tighten clamping pressure with handwheel.

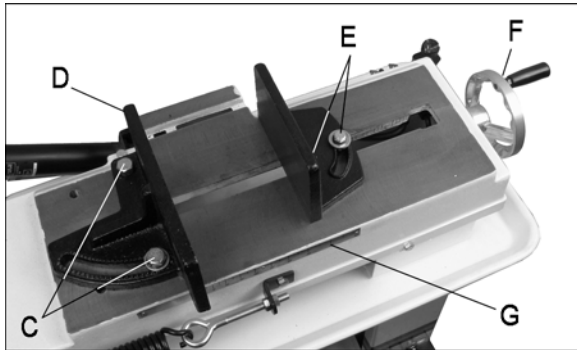

Figure 15

### 9.3.2 Miter cut

1. Loosen screws on fixed jaw (C, Figure 16), and floating jaw (E).
2. Swing both jaws to match desired angle on scale (G). Tighten screws (C).

Note: The angle scale is sufficient for most mitering operations. If greater precision is needed, verify setting with a protractor.

3. Loosen screws (E) on floating jaw, and use handwheel (F) to bring floating jaw into contact

with workpiece, allowing it to conform to the angle.

4. Tighten screws (E).
5. Tighten clamping pressure with handwheel.

### 9.3.3 Extended capacity

1. Remove two screws (C, Figure 16).
2. Reposition fixed vise in the secondary holes (H).
3. Reinstall screws (C) and tighten.

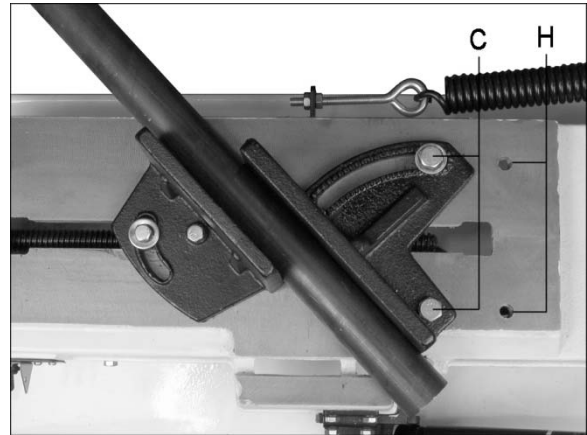

Figure 16

## 9.4 Setting feed rate

The feed rate of the blade into the workpiece is important to band saw performance. Excessive pressure of blade against the workpiece may break the blade or stall the saw. In contrast, insufficient pressure rapidly dulls the blade.

The hydraulic cylinder resists movement of the bow in the downward direction. It offers no resistance when the bow is raised.

To increase feed rate, turn dial (A, Figure 17) counterclockwise. To decrease, turn clockwise.

To close hydraulic flow, turn lever (B) down, perpendicular to cylinder, as shown in Figure 17. To open hydraulic flow, turn lever (B) parallel to cylinder.

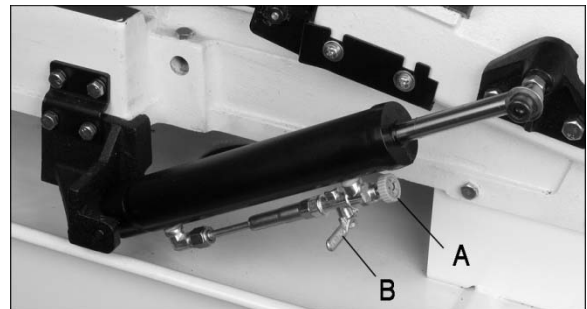

Figure 17

Feed rate is adjusted by the operator until the saw is operating efficiently, usually determined by

observing chip formation. See *section 11.4, Evaluating cutting efficiency.*

## 9.5 Counterbalance spring

The counterbalance spring helps control the amount of weight the saw bow puts on the workpiece when the hydraulic control valve is fully open. The hydraulic cylinder will not compensate for improper counterbalance.

If the spring is not set properly, one can expect poor performance, crooked cuts, tooth stripping, stalling, and/or the blade running off the wheels.

Spring tension has been set by the manufacturer, and should not require adjustment. If future problems arise, indicating improper counterbalance, adjust spring as follows:

1. Disconnect machine from power source.
2. Turn ON hydraulic cylinder valve and place saw bow in horizontal position.
3. Turn feed rate valve on hydraulic cylinder counterclockwise until it stops.
4. Place a weigh scale (such as a spring or hanging scale) beneath blade tension handle, and lift saw bow. Scale should indicate approximately 5 to 6 kg (11-13 lb).
5. If adjustment is needed, loosen one nut and tighten the other (A, Figure 18) on the eye bolt, until scale indicates 5 to 6 kg.

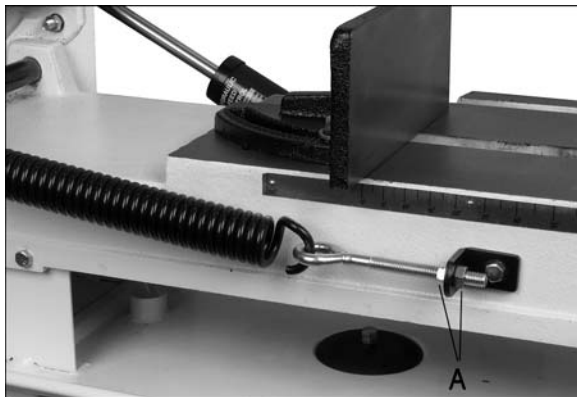

Figure 18

## 9.6 Blade installation/replacement

**CAUTION** This band saw is designed for use with blades that are 3/4" wide by 0.032" thick x 93" long. Use of blades with different specification may cause inferior performance.

A general-use variable-tooth blade is provided with this band saw.

The choice of blade pitch is governed by the thickness of the work to be cut: the thinner the workpiece, the more teeth advised. A minimum of three teeth should engage the workpiece at all times. If the teeth of the blade are so far apart that

they straddle the work, severe damage to the workpiece and to the blade can result.

To replace a blade:

1. Disconnect machine from power source.
2. Raise bow to vertical position, and secure in place by turning off hydraulic cylinder.
3. Remove red blade guard by removing two screws (A, Figure 19).

**WARNING** Red blade guard must be reinstalled after new blade is fitted.

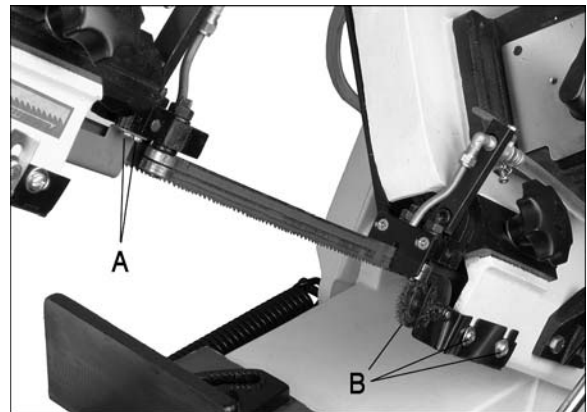

Figure 19

4. Remove brush assembly (B, Figure 19) by removing two screws.
5. Loosen blade tension by turning handle (C, Figure 20) counterclockwise.

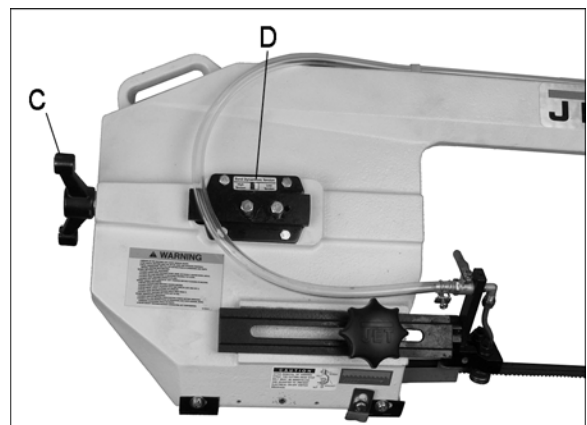

Figure 20

6. Open back cover by loosening two lock knobs.
7. Carefully remove old blade. *NOTE: Leather gloves are recommended when handling saw blades.*
8. Install new blade first between bearing guides. Make sure blade teeth face same direction as shown on the blade direction label on saw. (If teeth still point in wrong direction despite mounting blade properly, the blade has been turned inside-out. Twist blade right side-out and reinstall.)

9. Position blade around wheels, making sure it rests near the flange on both wheels.
10. Tension blade using handle. Do not over-tension. See *section 9.7, Blade tension*.
11. Close back cover and secure with knobs.
12. Install red blade guard, and brush assembly.
13. Connect machine to power source.
14. Run machine to verify that blade is tracking properly. See *section 9.8, Blade tracking*.

## 9.7 Blade tension

**⚠WARNING** Disconnect machine from power source, and use caution when working with sharp blade.

Blade tension is vital to achieving proper results from the band saw. For shipping purposes, the blade may not be at full tension – verify tension before operating.

Proper blade tension is 1550 to 1760 kg/cm<sup>2</sup> (22000-25000 lb/in<sup>2</sup>) as measured on a blade tension gauge (not provided).

To set tension without the use of a tension gauge:

1. Disconnect machine from power source.
2. Install blade between wheels and between bearings on blade guides.
3. Lightly tension blade to remove any sag by turning handle (C, Figure 20) slightly clockwise.
4. Turn tension handle (C, Figure 20) 1-3/4 to two revolutions clockwise. This is equivalent to 800 kg (1764 lb) of blade tension.

**⚠CAUTION** Do not overtighten blade; this may cause it to stretch or warp.

5. Close covers, connect to power source, and run saw for 2 to 3 minutes to allow blade to seat properly.
6. Disconnect machine from power source. Open cover and loosen blade until it just begins to sag.
7. Tighten blade until it straightens between blade wheels and all sag is eliminated.
8. Tighten blade by turning handle (C, Figure 20) two full revolutions.

**TIP:** Slacken blade tension when finished with operations, to prolong blade life. Make note of indicator position on tension label (D, Figure 20) for quickly returning tension to its previous setting.

## 9.8 Blade tracking

**⚠WARNING** Tracking the blade requires that the band saw be operating while the back cover is removed. This adjustment should be performed by qualified persons only.

Blade tracking has been tested at the factory. Adjustment is rarely required when the blade is used properly and if the blade is correctly welded. If a tracking problem occurs, first inspect blade condition, then adjust tracking as follows:

1. Raise bow to vertical position and secure by turning off hydraulic cylinder valve.
2. The blade should be properly tensioned. Refer to *section 9.7 Blade tension*.
3. Open back cover.

**⚠CAUTION** While performing the following steps, keep the blade from rubbing excessively on wheel flange. Excess rubbing will damage wheel and/or blade.

4. Start saw and observe blade movement. Blade should run next to, but not tightly against, wheel flange.
5. If blade will not track in position, loosen screws (E, Figure 21), but do not remove.
6. Turn set screw (F, Figure 21) counter-clockwise so that blade starts to move away from the flange; then immediately turn set screw in the other direction so that blade stops, then moves slowly back toward flange. NOTE: This adjustment is sensitive; do it gradually and in small increments allowing blade to respond to the changes.

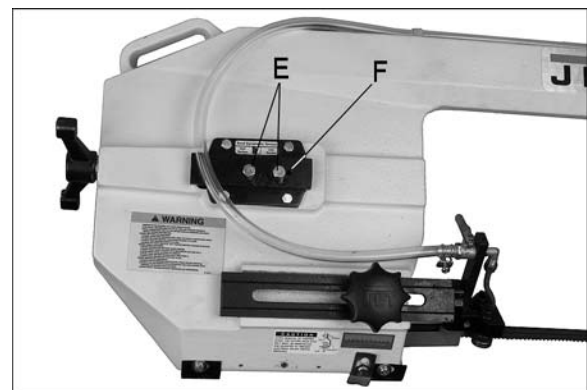

Figure 21

**⚠WARNING** Keep fingers clear of blade and wheel to avoid injury.

7. Turn set screw to stop shifting of blade on the wheel as it gets closer to wheel flange. Put a six-inch length of paper between blade and wheel. The paper should not be cut as it passes between wheel flange and blade.

8. Turn set screw a small amount. Repeat the insertion of paper between wheel flange and blade until paper is cut into two pieces.

NOTE: You may have to repeat the check with the paper several times before the blade and the flange cut the paper into two pieces. Do not hurry the adjustment. Patience and accuracy here will pay off with better, more accurate, quieter cutting and longer machine and blade life.

9. When the paper is cut, back off the set screw slightly. This assures that the blade is not touching the flange of the wheel.

10. Tighten two screws (E, Figure 21).

### 9.9 Test cutting to verify adjustment

Test cuts can be used to determine whether or not you have adjusted the blade accurately. Use 2-inch round bar stock to perform these test cuts, as follows:

1. With bar stock securely clamped in the vise, make a cut through the bar stock (see Figure 22.)
2. Mark the top of the bar stock.
3. Move the bar stock about 1/4-inch past the blade so that you can begin a second cut.
4. Rotate the bar stock 180 degrees so the mark you made is now at the bottom of the cut.
5. Make a cut through the bar stock.
6. Use a micrometer to measure the thickness variation of the disk you have cut from the bar stock. Measure at top and bottom of disk.

The saw blade can be considered correctly adjusted when the variation measure is no more than 0.012 inch across the face of the disk.

If you do not have a piece of 2-inch bar stock available for a test cut, use a larger diameter test piece rather than a smaller one. The maximum thickness variation on any test piece should be no more than 0.003 inch, per side, per inch of stock diameter.

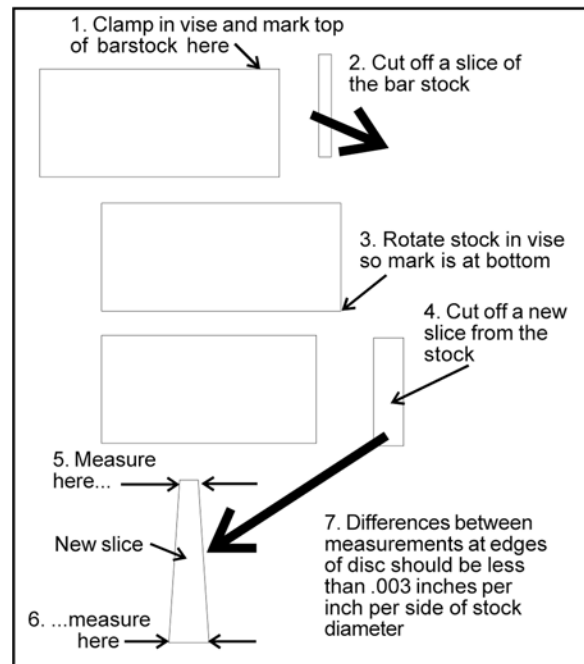

Figure 22

### 9.10 Blade speed

1. Turn machine OFF.
2. Turn lever (Figure 23) to desired setting –
  - 1 = 145 feet per minute
  - 2 = 200 feet per minute
  - 3 = 245 feet per minute

**⚠CAUTION** Do not change blade speed during cutting operation.

Material chips or shavings are the best indicator of proper blade speed and downfeed rate. See section 11.4, *Evaluating cutting efficiency*.



Figure 23

## 9.11 Blade guide adjustment

1. Loosen knobs (A, Figure 24).
2. Slide guide assemblies as close to workpiece as possible without interfering with cut. This will prevent excessive blade exposure, and deflection of blade during cutting.
3. Retighten knobs.

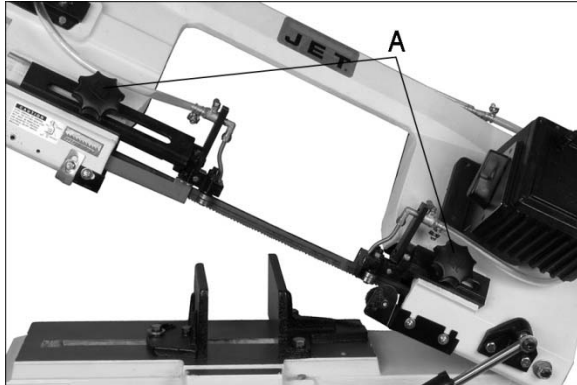

Figure 24

The guide bearings come pre-adjusted from the factory, but should be inspected frequently and adjustments made as needed.

For most efficient operation and maximum accuracy, provide 0.001" clearance between the blade and the guide bearings. The bearings will still turn freely with this clearance. If the clearance is incorrect, the blade may track off the drive wheel.

1. Disconnect machine from power source.
2. Raise bow to vertical and secure in place by turning off hydraulic cylinder.
3. Loosen socket head cap screw (B, Figure 25) and adjust guide assembly until back roller bearing (C) is slightly contacting back edge of blade.

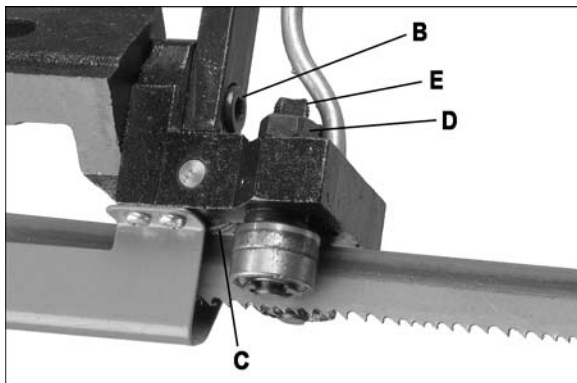

Figure 25

4. Loosen nut (D) and rotate eccentric shaft (E) to adjust side bearing until bearing just touches side of blade. Do not pinch the blade.
5. Blade should still move up and down freely when grasped as in Figure 26. Make sure blade teeth do not interfere with guide bearings.

## **⚠WARNING**

Make sure power is disconnected and hands are protected before handling blade.

6. Tighten nut (D).
7. Repeat for other blade guide assembly.

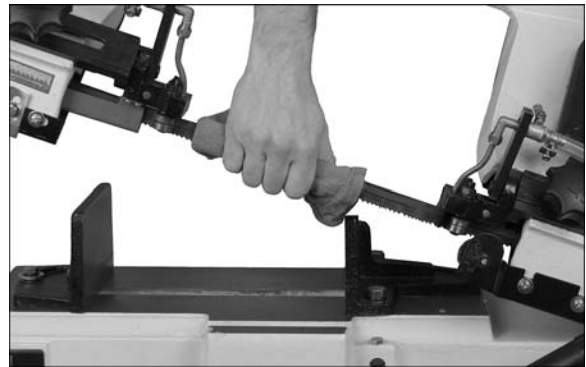

Figure 26

## 9.12 Chip brush

The chip brush (B, Figure 19) must be properly adjusted and maintained in working condition; otherwise damage to blade can occur. Adjust the brush so that its bristles overlap the blade.

Replace brush if it becomes worn or damaged.

## 9.13 On/off switch

### **⚠CAUTION**

The stop screw (A, Figure 27) must be properly adjusted to prevent damage to the on/off switch.

Make sure the stop screw (A, Figure 27) is properly adjusted in conjunction with the shut-off tab (B, Figure 27). Too much pressure from the shut-off tab can damage the on/off switch.



Figure 27

## 10.0 Operating controls

To start saw, toggle switch (C, Figure 27) to ON.

To stop saw before it reaches the end of cut, toggle switch (C) to OFF. Otherwise, saw will automatically stop at the end of a cut.

Toggle the coolant switch (D, Figure 28) to ON. Flow of coolant to blade area is controlled by the taps connected to the blade guide assemblies.

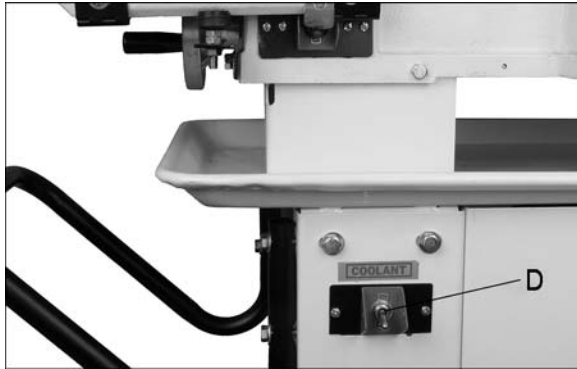

Figure 28

**IMPORTANT:** When cutting magnesium, never use soluble oils or emulsions (oil-water mix) as water will greatly intensify any accidental magnesium chip fire. See your industrial coolant supplier for specific coolant recommendations when cutting magnesium.

## 11.0 Operation

### 11.1 Pre-Operation inspection

Give machine an overall inspection and verify the following:

1. Guards and covers are in place and in working order.
2. Blade tooth direction matches diagram on bow.
3. Blade is properly tensioned, and tracking correctly on wheels.
4. Side and rear blade guide bearings are properly adjusted.
5. Coolant level is sufficient.
6. Gearbox is properly lubricated.
7. Do not begin cut on a sharp edge; file edge first.

### 11.2 Blade break-in procedure

New blades are very sharp and, therefore, have a tooth geometry which is easily damaged if a careful break-in procedure is not followed. Consult the blade manufacturer's literature for break-in of specific blades on specific materials. However, the

following procedure will be adequate for break-in of JET-supplied blades on lower alloy ferrous materials.

1. Clamp a round section workpiece in the vise. The workpiece should be 2 inches or larger in diameter.
2. Set the saw on low speed. Start the cut with a very light feed rate.
3. When the saw has completed 1/3 of the cut, increase the feed rate slightly and allow the saw to complete the cut.
4. Keep the same hydraulic cylinder setting and begin a second cut on the same or similar workpiece.
5. When the blade has completed about 1/3 of the cut, increase feed rate. Watch the chip formation until cutting is at its most efficient rate and allow the saw to complete the cut (see section 11.4, *Evaluating cutting efficiency*).
6. The blade is now ready for regular service.

### 11.3 General operating procedure

1. Raise bow until it will clear workpiece by a few inches, and close hydraulic cylinder valve to secure it in place.

**NOTE:** Never start a cut with blade contacting workpiece.

2. Place workpiece in vise and tighten vise. The workpiece should be fitted directly between the jaws without adding other objects.

When workpiece to be cut is a profiled section, flat piece or special shape, refer to examples in Figure 29 for proper clamping positions. The top row shows acceptable clamping positions; the bottom row shows **un**acceptable positions.

If thickness of profiled section is very thin, a piece which duplicates the profile should be fitted inside the workpiece itself, to prevent workpiece being crushed between the jaws.

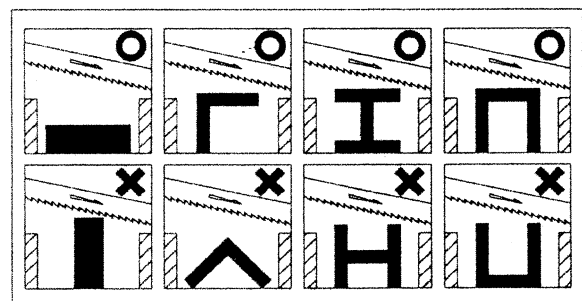

Figure 29

**WARNING** Never hold a workpiece by hand when cutting it – the workpiece should be firmly secured in the vise. Do not reach into the cutting area during cutting operations.

3. Position work stop if needed.
4. Position blade guides as close to workpiece as possible.
5. Move speed setting lever to desired position. **Do not move speed setting lever during a cutting operation.**
6. Set a suitable feed rate for that operation on the hydraulic cylinder dial.
7. Toggle ON switch to begin blade rotation. Allow blade to reach full speed before beginning cut.
8. Turn on coolant flow. Adjust flow valves as needed.
9. Open valve on hydraulic cylinder to allow bow to descend in a gradual and controlled manner.
10. The machine will shut off at the completion of the cut. Turn off coolant flow and remove workpiece.
11. Return bow to raised position for next cut.

#### 11.4 Evaluating cutting efficiency

Is the blade cutting efficiently? The best way to determine this is to observe the chips formed by the cut.

If chip formation is powdery, then the feed rate is much too light, or the blade is dull.

If chips are curled, but colored — that is, either blue or straw-colored from heat generated during the cut — then the feed rate is too high.

If chips are slightly curled and are not colored by heat, the blade is sufficiently sharp and is cutting at its most efficient rate.

## 12.0 Maintenance

**⚠WARNING** Before doing maintenance on the machine, disconnect it from the electrical supply by pulling out the plug or switching off the main switch! Failure to comply may cause serious injury.

Keep all surfaces clean and free of rust, slag, chips, and coolant build-up.

Clear metal particles with a small paint brush or parts cleaning brush.

Clean filter screen.

Do not use compressed air, as it may force chips into the guide bearings and other critical areas of the saw.

Wipe saw down with a clean, dry cloth, and oil all unpainted surfaces with light machine oil.

Keep blade guides clean and free of metal particles.

Check guide bearings frequently to make sure that they are properly adjusted and turning freely.

Grease the vise lead screw (Figure 30) as needed, with a general purpose grease.

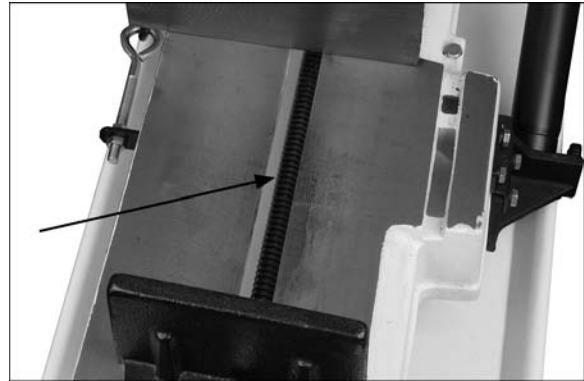

Figure 30

If the power cord is worn, cut, or damaged in any way, have it replaced immediately.

Ball bearings on blade guide assemblies and blade wheels are permanently lubricated and sealed. They require no further lubrication.

Place a thin coat of oil on the table surface on which the vise jaw slides.

#### 12.1 Coolant level

Maintain coolant level. Low coolant level can cause foaming and high blade temperatures. Replace dirty coolant; dirty or weak coolant can clog the pump, cause crooked cuts, a low cutting rate and/or permanent blade damage. To fill the tank, remove the filter cup and pour coolant into the hole to about 80% of full capacity. Full capacity is 9 liters (2.5 gal). Follow coolant manufacturer's instructions for proper use and disposal.

#### 12.2 Gear box

To change gear box oil:

1. Disconnect machine from power source.
2. Place bow in vertical position.
3. Remove drain plug (A, Figure 31) and drain oil. (Follow local regulations for disposal of used oil.)
4. Reinstall drain plug and return bow to horizontal position.
5. Remove vent plug (B), and fill gear box through the hole with approximately 0.3L (10.14 oz.) of 90W oil.
6. Reinstall vent plug (B).

Completely drain and refill gear box after the first 90 days of operation. Thereafter, change every six months.

Periodically, after draining remove screws, cover and gasket, and wipe out residual oil from gearbox interior with a rag, before refilling. Also do this if changing oil brands.

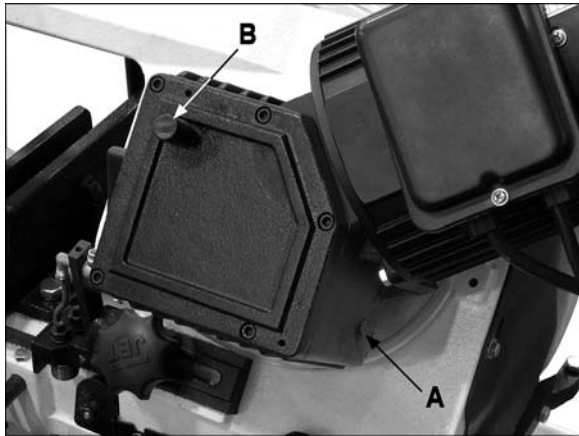

Figure 31

## 13.0 Troubleshooting the HBS-812G

Trouble	Probable Cause	Remedy
Motor will not start.	No incoming power.	Check plug connection.
	Blown electrical panel fuses or tripped circuit breakers.	Replace fuses, or reset breakers.
	Defective motor, switch, power cable, or plug.	Qualified electrician/service personnel should inspect these items.
Band Saw vibrates excessively.	Base on uneven surface.	Adjust base for even support.
	Saw blade has cracks.	Replace blade immediately.
	Too heavy a cut.	Reduce feed rate and blade speed.
Miter cuts not accurate.	Material not clamped properly, or vise screws not tightened.	Tighten vise screws securely. Use an adjustable square or protractor to verify angle settings.
	Blade is worn, cutting crooked.	Replace blade.
Cuts not square.	Feed rate too fast.	Decrease feed rate.
	Incorrect blade tothing in relation to workpiece.	Check <i>Machinery's Handbook</i> for recommended blade type.
	Blade is worn, cutting crooked.	Replace blade.
	Incorrect adjustment of bearing guides and guide assembly.	Readjust guide assemblies.
	Workpiece incorrectly positioned in vise.	Check positioning and clamping in the vise.
	Poor blade tension.	Check and correct if needed.
Finished surface of workpiece is rough, unsatisfactory.	Blade is dull.	Replace blade.
	Improper blade for cutting operation.	Check <i>Machinery's Handbook</i> for blade recommendations.
	Feed rate too fast.	Reduce feed rate.
	Blade tension too low.	Increase blade tension.

<b>Trouble</b>	<b>Probable Cause</b>	<b>Remedy</b>
Excessive blade breakage.	Incorrect blade tension.	Adjust blade tension.
	Incorrect blade speed or feed rate.	Adjust accordingly.
	Workpiece loose in vise.	Clamp workpiece securely.
	Blade rubs on wheel flange.	Adjust blade tracking.
	Teeth too coarse for material.	Use appropriate blade for material.
	Teeth in contact with workpiece before saw is started.	Start motor before blade contacts workpiece.
	Blade guides are misaligned.	Adjust blade guides as needed.
	Blade too thick for wheel diameter.	Use thinner blade.
	Cracking at weld; poor annealing of blade.	Replace blade.
Unusual wear on side/back of blade,	Blade guides worn.	Replace guides.
	Blade guide bearings not adjusted.	Adjust blade guide bearings.
	Blade guide bearing bracket is loose.	Tighten blade guide bearing bracket
Premature blade dulling.	Teeth too coarse.	Use finer tooth blade.
	Blade speed too fast.	Reduce speed.
	Inadequate feed rate.	Adjust cylinder dial setting as needed.
	Hard spots or scale on material.	Hard Spots: Increase feed rate. Scale: Reduce speed and increase feed rate.
	Work hardening of material (especially stainless steel)	Increase feed rate.
	Blade installed backwards.	Remove blade, twist inside-out and re-install.
	Insufficient blade tension.	Adjust as needed.
No coolant flow.	Pump motor burned out.	Replace pump.
	Filter screen clogged.	Clean filter screen.
	Coolant level low.	Add coolant to tank.

## 14.0 Replacement Parts

Replacement parts are listed on the following pages. To order parts or reach our service department, call 1-800-274-6848 Monday through Friday, 8:00 a.m. to 5:00 p.m. CST. Having the Model Number and Serial Number of your machine available when you call will allow us to serve you quickly and accurately.

Non-proprietary parts, such as fasteners, can be found at local hardware stores, or may be ordered from JET.

Some parts are shown for reference only, and may not be available individually.

# 14.1.1 HBS-812G Table and Stand Assembly – Exploded View

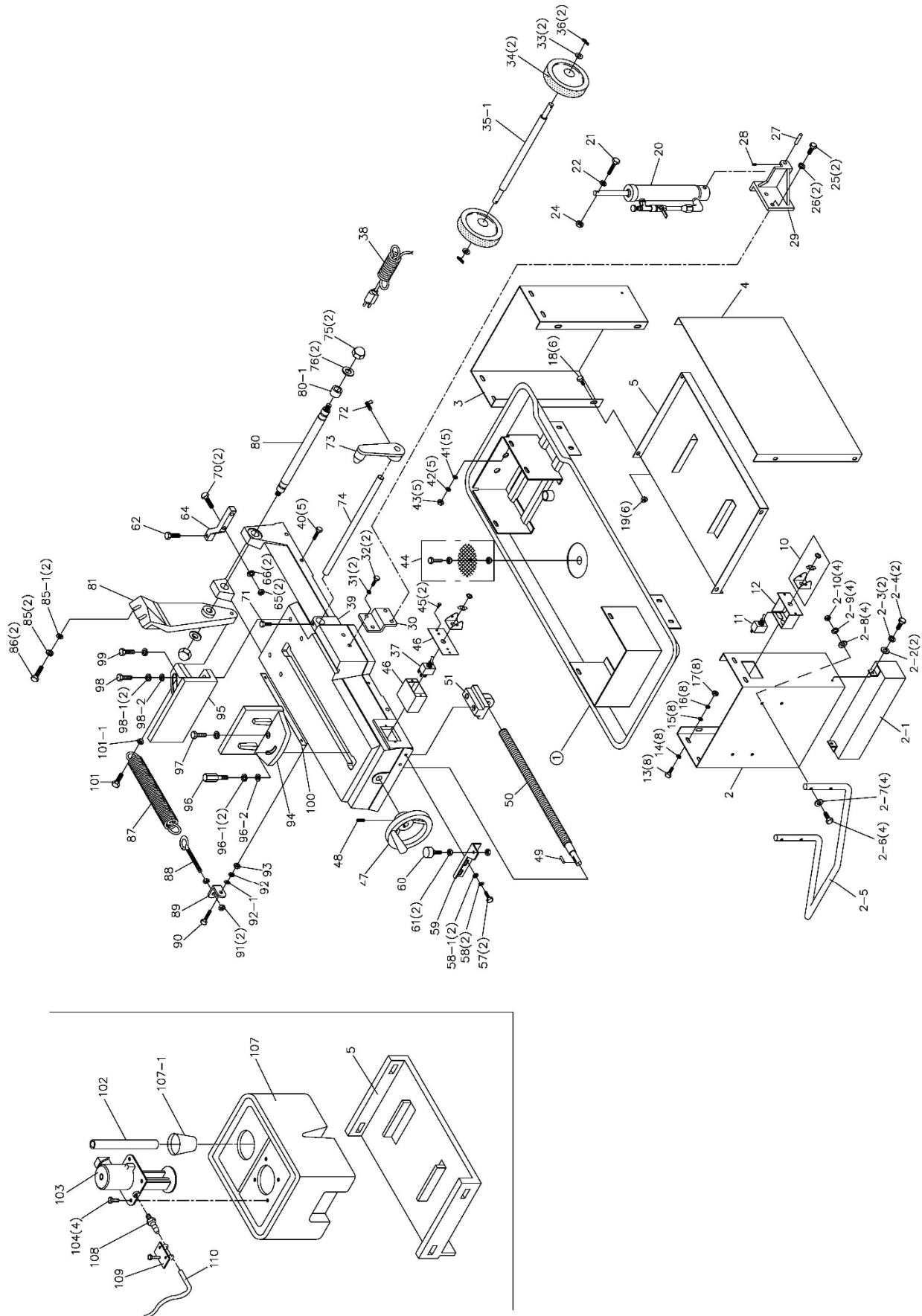

14.1.2 HBS-812G Bow Assembly – Exploded View

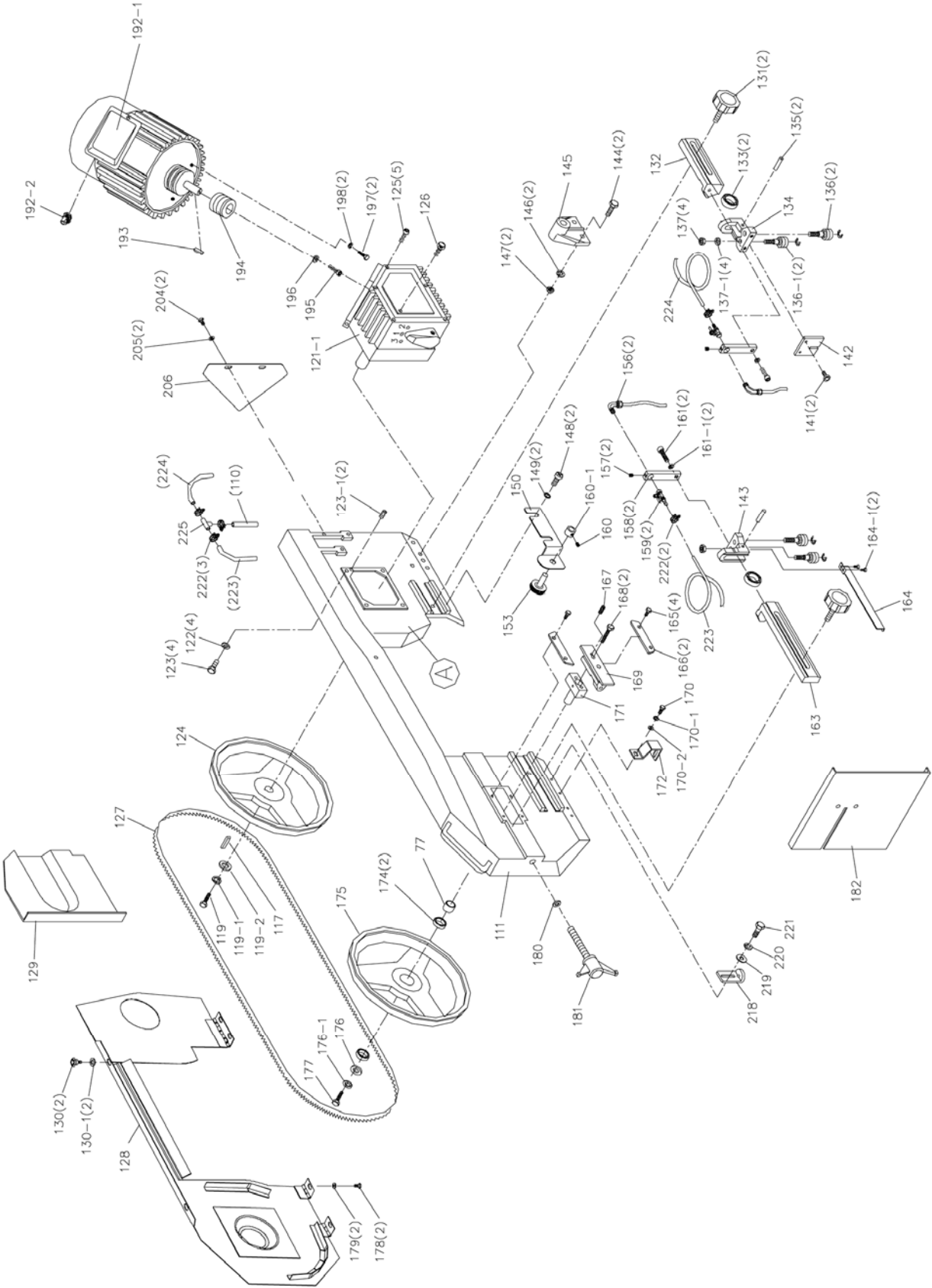

### 14.1.3 HBS-812G Table, Bow, Stand Assemblies – Parts List

Index No.	Part No.	Description	Size	Qty
1	HBS812G-1G	Bottom Pan		1
2	HBS812G-2G	Leg (Left)		1
2-1	HBS812G -2-1	Foot Stand		1
2-2	TS-0680021	Flat Washer	1/4"	2
2-3	TS-0720071	Spring Washer	1/4"	2
2-4	TS-0050031	Hex Cap Screw	1/4" x 3/4"	2
2-5	HVBS710S-13	Handle		1
2-6	TS-0051071	Hex Cap Screw	5/16" x 1-1/2"	4
2-7	TS-0680041	Flat Washer	5/16"	4
2-8	TS-0680041	Flat Washer	5/16"	4
2-9	TS-0720081	Spring Washer	5/16"	4
2-10	TS-0561021	Hex Nut	5/16"	4
3	HBS812G-3G	Leg (Right)		1
4	HBS812G-4G	Front Panel		1
5	HBS812G-5G	Shelf		1
10	HBS812G-10	Switch Bracket		1
11	HBS812G-11	Toggle Switch		1
12	HBS812G-12	Switch Box		1
13	TS-0081031	Hex Cap Screw	5/16" x 3/4"	8
14	TS-0680041	Flat Washer	5/16"	8
15	TS-0680041	Flat Washer	5/16"	8
16	TS-0720081	Spring Washer	5/16"	8
17	TS-0561021	Hex Nut	5/16"	8
18	TS-0051011	Hex Cap Screw	5/16" x 1/2"	6
19	TS-0561021	Hex Nut	5/16"	6
20	HBS812G-20	Hydraulic Cylinder		1
21	TS-1505061	Socket Head Cap Screw	M10 x 40	1
22	TS-0680041	Flat Washer	3/8"	1
24	TS-1540071	Hex Nut	M10	1
25	TS-0051051	Hex Cap Screw	5/16" x 1"	2
26	TS-0720081	Spring Washer	5/16"	2
27	HBS812G-27	Support Pin		1
28	TS-0267041	Socket Set Screw	1/4" x 3/8"	1
29	HBS812G-29	Bottom Support		1
30	HBS812G-30	Holding Plate		1
31	TS-0720081	Spring Washer	5/16"	2
32	TS-0051021	Hex Cap Screw	5/16" x 5/8"	2
33	TS-0680061	Flat Washer	1/2"	2
34	HVBS710S-16	Wheel	8"	2
35-1	HBS812G-35-1	Axle	17"	1
36	HVBS710S-19	Cotter Pin		2
37	HBS812G-37	Toggle Switch		1
38	HBS812G-38	Electric Cord Assembly		1
39	HBS812G-39G	Table		1
40	TS-0051051	Hex Cap Screw	5/16" x 1"	5
41	TS-0680041	Flat Washer	5/16"	5
42	TS-0720081	Spring Washer	5/16"	5
43	TS-0561021	Hex Nut	5/16"	5
44	HVBS710S-26	Filter		1
45	HVBS710SG-204	Round Hd. Screw	3/16" x 3/8"	2
46	HBS812G-46	Switch Box Assembly		1
47	HVBS710S-82	Handwheel		1
48	TS-0270031	Socket Set Screw	5/16" x 3/8"	1
49	HVBS710S-85	Key	5 x 20mm	1
50	HVBS710S-84	Lead Screw		1
51	HBS812G-51	Nut Seat		1
57	TS-0051021	Hex Cap Screw	5/16" x 5/8"	2
58	TS-0720081	Spring Washer	5/16"	2
58-1	TS-0680041	Flat Washer	5/16"	2

Index No.	Part No.	Description	Size	Qty
59	HBS812G-59	Support Bracket		1
60	HBS812G-60	Stop Screw		1
61	TS-0561021	Hex Nut	5/16"	2
62	TS-0060051	Hex Cap Screw	3/8" x 1"	1
64	HBS812G-64	90° Position Support		1
65	TS-0561031	Hex Nut	3/8"	2
66	TS-0720091	Spring Washer	3/8"	2
70	TS-0060071	Hex Cap Screw	3/8" x 1-1/2"	2
71	TS-0081031	Hex Cap Screw	5/16" x 3/4"	1
72	HVBS710S-107	Thumb Screw		1
73	HBS812G-73	Work Stop		1
74	HBS812G-74	Work Stop Rod		1
75	TS-0640112	Nylon Hex Nut	1/2"	2
76	TS-0680061	Flat Washer	1/2"	2
77	HVBS710S-182	Bearing Bushing		1
80	HVBS710S-62	Pivot Shaft	22mm	1
80-1	HVBS710S-61	Bushing	Ø22 x 28 x 7mm	1
81	HBS812G-81G	Pivot Arm		1
85	TS-0720091	Spring Washer	3/8"	2
85-1	TS-0680041	Flat Washer	3/8"	2
86	TS-0060071	Hex Cap Screw	3/8" x 1-1/2"	2
87	HVBS710S-126	Spring		1
88	HVBS710S-125	Spring Adjusting Rod	3/8"	1
89	HVBS710S-124	Spring Bracket		1
90	TS-0051051	Hex Cap Screw	5/16" x 1"	1
91	TS-0561031	Hex Nut	3/8"	2
92	TS-0720081	Spring Washer	5/16"	1
92-1	TS-0680041	Flat Washer	5/16"	1
93	TS-0561021	Hex Nut	5/16"	1
94	HBS812G-94	Floating Vise Jaw		1
95	HBS812G-95	Fixed Vise Jaw		1
96	HVBS710S-119	Hexagonal Stud		1
96-1	TS-0720091	Spring Washer	3/8"	2
96-2	TS-0680041	Flat Washer	3/8"	1
97	TS-0060071	Hex Cap Screw	3/8" x 1-1/2"	1
98	TS-0070031	Hex Cap Screw	1/2" x 1-1/2"	1
98-1	TS-0720111	Spring Washer	1/2"	2
98-2	TS-0680061	Flat Washer	1/2"	1
99	TS-0100041	Hex Cap Screw	1/2" x 1-1/4"	1
100	HBS812G-100	Scale		1
101	TS-0209080	Socket Head Cap Screw	3/8" x 1-3/4"	1
101-1	TS-0561032	Hex Nut	3/8"	1
102	HVBS710S-5	Clear Hose	1"	1
103	HVBS710S-6	Pump	1/8HP 1PH	1
104	TS-0050011	Hex Cap Screw	1/4" x 1/2"	4
107	HVBS710S-12	Coolant Tank	9L	1
107-1	HVBS7MW-66-1N	Plastic Funnel		1
108	HVBS710S-9	Hose Fitting		1
109	HVBS710S-10	Hose Clamp	13 mm	1
110	HVBS710S-11	Hose	5/16"	1
111	HBS812G-111G	Bow		1
117	HVBS710SG-130	Key	6 x 6 x 20mm	1
119	TS-0060051	Hex Cap Screw	3/8" x 1"	1
119-1	TS-0720091	Spring Washer	3/8"	1
119-2	TS-0680041	Flat Washer	3/8"	1
121-1	HVBS710SG-196-1	Gear Box Assembly (serial No. 150400349 and lower)		1
121-1	HVBS710SG-196-1N	Gear Box Assembly (serial No. 150600350 and higher)		1
122	TS-0720081	Spring Washer	5/16"	4
123	TS-0051061	Hex Cap Screw	5/16" x 1-1/4"	4
123-1	TS-0267041	Socket Set Screw	1/4" x 3/8"	2
124	HVBS710S-133	Drive Wheel		1
125	TS-1503051	Socket Head Cap Screw (serial No. 150400349 and lower)	6 x 20mm	5

Index No.	Part No.	Description	Size	Qty
126	HVBS710SG-129	Vent Plug		1
127		Blade (local purchase)	3/4" x 0.032" x 93"	1
128	HBS812G-128	Blade Back Cover		1
129	HVBS710S-136	Wheel Cover		1
130	HVBS710S-137	Knob	1/4"	2
130-1	TS-0680021	Flat Washer	1/4"	2
131	HVBS710S-140	Adjustable Guide Knob	3/8"	2
132	HVBS710S-141	Adjustable Bracket (Rear)		1
133	BB-608ZZ	Ball Bearing	608ZZ	2
134	HVBS710S-144	Adjustable Blade Seat (Rear)		1
135	HVBS710S-143	Bearing Pin	8mm	2
136	HVBS710S-146	Eccentric Shaft Assembly		2
136-1	HVBS710S-146-1	Center Shaft Assembly		2
137	TS-0561032	Hex Nut	3/8" x 24UNF	4
137-1	TS-0720091	Spring Washer	3/8"	4
141	TS-081F031	Flat Head Screw	1/4" x 1/2"	2
142	HVBS710S-147-1	Seat Plate		1
143	HVBS710S-144-1	Adjustable Blade Seat (Front)		1
144	TS-0060061	Hex Cap Screw	3/8" x 1-1/4"	2
145	HBS812G-145	Top Support		1
146	TS-0720091	Spring Washer	3/8"	2
147	TS-0561032	Hex Nut	3/8"	2
148	HVBS710S-139	Round Hd. Screw	1/4" x 1/2"	2
149	TS-0680021	Flat Washer	1/4"	2
150	HVBS710S-158	Brush Holder		1
153	HVBS710S-161	Brush		1
156	HVBS710S-163	Nozzle Cock		2
157	TS-0267041	Socket Set Screw	1/4" x 3/8"	2
158	HVBS710S-164	Nozzle Cock Support		2
159	HVBS710S-170	Valve		2
160	TS-0267021	Socket Set Screw	1/4" x 1/4"	1
160-1	HVBS710S-160	Fixed Bushing		1
161	HVBS710S-166	Hex Cap Screw	5/16" x 1-1/8"	2
161-1	TS-0720081	Spring Washer	5/16"	2
163	HVBS710S-173	Adjustable Bracket (Front)		1
164	HVBS710S-174	Blade Guard		1
164-1	HVBS710S-175	Round Hd. Screw	3/16" x 1/4"	2
165	TS-0050011	Hex Cap Screw	1/4" x 1/2"	4
166	HVBS710S-176	Sliding Guide Plate		2
167	TS-0270071	Socket Set Screw	5/16" x 3/4"	1
168	TS-0051071	Hex Cap Screw	5/16" x 1-1/2"	2
169	HVBS710S-178	Blade Tension Sliding Block		1
170	TS-0050011	Hex Cap Screw	1/4" x 1/2"	1
170-1	TS-0720071	Spring Washer	1/4"	1
170-2	TS-0680021	Flat Washer	1/4"	1
171	HVBS710S-181	Sliding Draw Block		1
172	HBS812G-172	Shipping Bracket		1
174	BB-6203ZZ	Ball Bearing	6203ZZ	2
175	HVBS710S-184	Idler Wheel		1
176	TS-0680041	Flat Washer	5/16"	1
176-1	TS-0720081	Spring Washer	5/16"	1
177	TS-0081031	Hex Cap Screw	5/16" x 3/4"	1
178	HVBS710S-139	Round Hd. Screw	1/4" x 1/2"	2
179	TS-0680021	Flat Washer	1/4"	2
180	TS-0680041	Flat Washer	3/8"	1
181	HVBS710S-188	Blade Tension Handle		1
182	HVBS710S-147	Vertical Cutting Plate		1
192-1	HVBS710SG-192-1	Motor	1HP 1PH	1
	HVBS710SG-192-MF	Motor Fan (not shown)		1
	HVBS710SG-192-MFC	Motor Fan Cover (not shown)		1
	HVBS710SG-192-JB	Junction Box		1
	HVBS710SG-192-JBC	Junction Box Cover		1

Index No.	Part No.	Description	Size	Qty
192-2	HVBS710SG-192-2	Strain Relief		1
193	HVBS710S-193	Key	5 x 5 x 20 mm	1
194	HVBS710SG-328	Worm Shaft		1
195	TS-1503051	Socket Head Cap Screw	6 x 20mm	1
196	HVBS710SG-195-1	Gear Flange		1
197	TS-1490031	Hex Cap Screw	8 x 20mm	2
198	TS-1550061	Spring Washer	8mm	2
204	TS-0050011	Hex Cap Screw	1/4" x 1/2"	2
205	TS-0680021	Flat Washer	1/4"	2
206	HVBS710S-189	Support Plate		1
218	HBS812G-218	Shut-off Tab		1
219	TS-0680021	Flat Washer	1/4"	1
220	TS-0720071	Spring Washer	1/4"	1
221	TS-0050011	Hex Cap Screw	1/4" x 1/2"	1
222	HVBS710S-171	Hose Clamp		5
223	HVBS710S-169	Hose		1
224	HVBS710S-168	Hose		1
225	HVBS710S-167	Connection Tube		1
226	HVBS710S-WL	Warning Label (not shown)		1
227	HVBS710S-LBDA	Label – Blade Direction Arrow (not shown)		1
228	HBS812G-ID	I.D. Label (not shown)		1
	HBS812G-HP	Hardware Package (see contents page 8)		1
	JET-92	JET Logo (not shown)	92x38mm	1

### 14.2.1 HBS-812G Gearbox Assembly – Exploded View

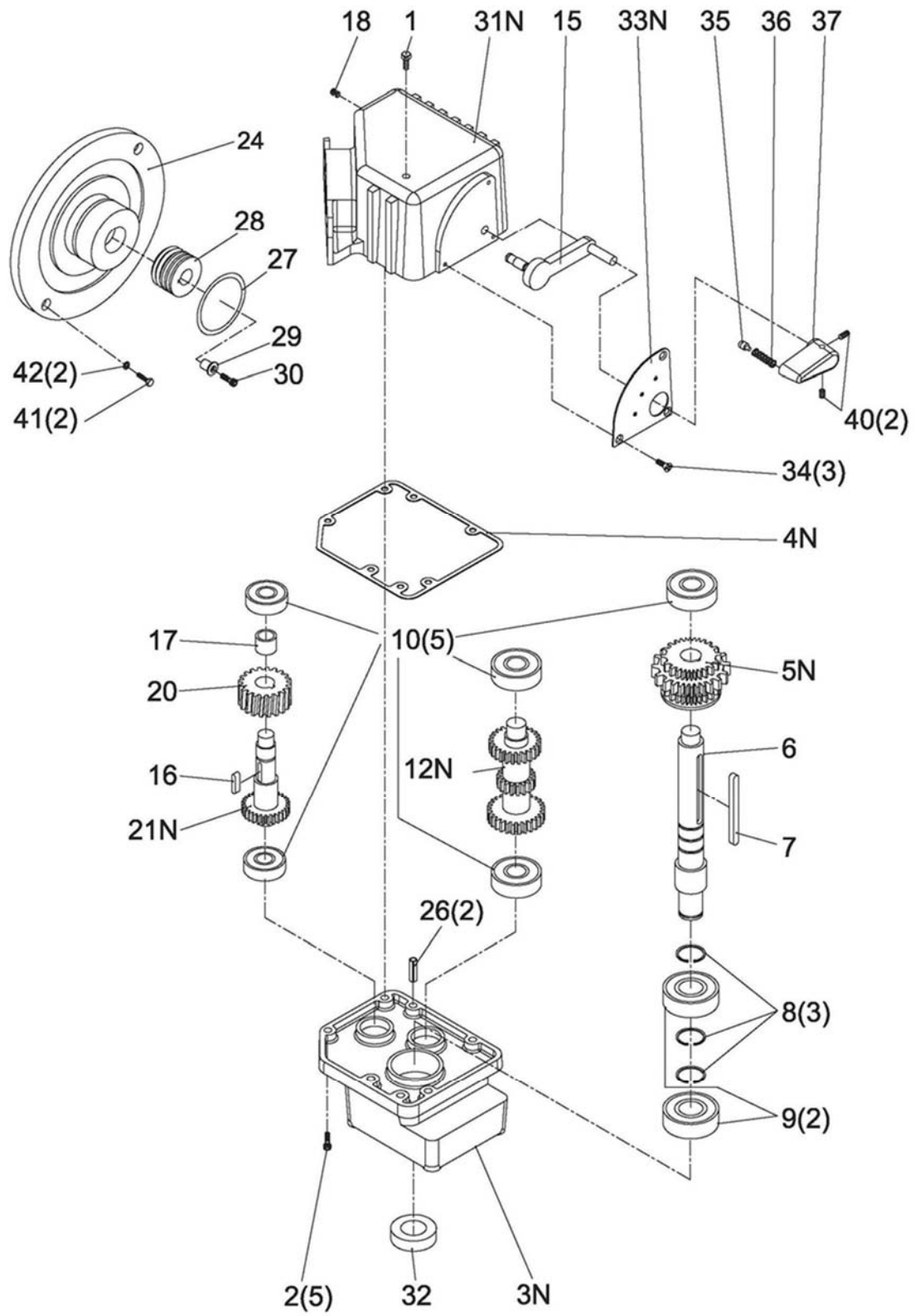

## 14.2.2 HBS-812G Gearbox Assembly – Parts List

Index No.	Part No.	Description	Size	Qty
	HVBS710SG-196-1N	Gearbox Assembly (index #1 thru 42) (serial #150600350 and higher)		1
1	HVBS710SG-129	Vent Plug		1
2	TS-1504061	Hex Socket Head Cap Screw	M8x30	5
3N	HVBS710SG-331N	Gear Box Base		1
4N	HVBS710SG-304N	Gasket		1
5N	HVBS710SG-305N	Drive Gear Assembly		1
6	HVBS710SG-306	Drive Shaft		1
7	HVBS710SG-307A	Key	5x5x75	1
8	HVBS710SG-308	C-Ring	S-25	3
9	BB-6205	Ball Bearing	6205Z	2
10	BB-6201	Ball Bearing	6201RS	5
12N	HVBS710SG-312N	Transfer Gears Assembly		1
15	HVBS710SG-315	Adjustable Bracket		1
16	HVBS710SG-316A	Key	6x6x12	1
17	HVBS710SG-317	Bushing		1
18	HVBS710SG-318	Drain Plug	1/4"	1
20	HVBS710SG-320	Worm Gear		1
21N	HVBS710SG-321N	Input Gear		1
24	HVBS710SG-324	Motor Cover		1
26	HVBS710SG-326	Set Pin	6x15	2
27	HVBS710SG-327	O-Ring	G60x3.5	1
28	HVBS710SG-328	Worm Shaft		1
29	HVBS710SG-329	Gear Flange		1
30	TS-1503051	Hex Socket Head Cap Screw	M6x20	1
31N	HVBS710SG-303N	Gear Box Housing		1
32	HVBS710SG-332	Oil Seal	30x40x8	1
33N	HVBS710SG-333N	Indicator Plate		1
34	TS-2284081	Flat Head Screw	M4x8	3
35	SB-1/4	Steel Ball	1/4"	1
36	HVBS710SG-336	Compression Spring	1/4"	1
37	HVBS710SG-337	Plastic Handle		1
40	JJP12-103	Set Screw	M8x6	2
41	TS-1490031	Hex. Head Screw	M8x20	2
42	TS-2361081	Spring Washer	M8	2

# 15.0 Electrical Connections for HBS-812G

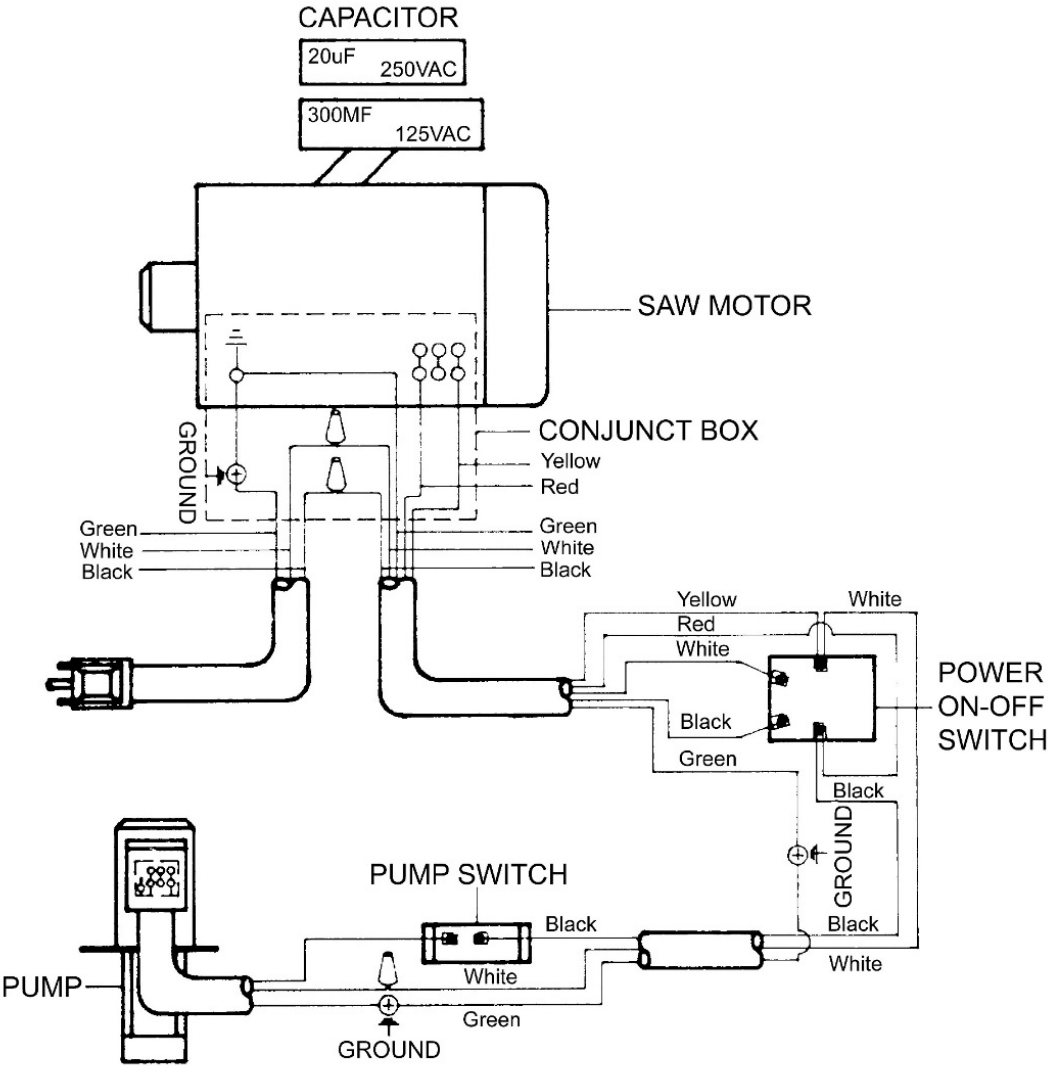

This page intentionally left blank.



427 New Sanford Road  
LaVergne, Tennessee 37086  
Phone: 800-274-6848  
[www.jettools.com](http://www.jettools.com)