



Operating Instructions and Parts Manual

Geared Head Drilling/Tapping Presses

Models GHD-20/20T/20PF/20PFT



Model GHD-20PFT shown

JET
427 New Sanford Road
LaVergne, Tennessee 37086
Ph.: 800-274-6848
www.jettools.com

Part No. M-354026
Revision J2 12/2017
Copyright © 2017 JET

Warranty and Service

JET® warrants every product it sells against manufacturers' defects. If one of our tools needs service or repair, please contact Technical Service by calling 1-800-274-6846, 8AM to 5PM CST, Monday through Friday.

Warranty Period

The general warranty lasts for the time period specified in the literature included with your product or on the official JET branded website.

- JET products carry a limited warranty which varies in duration based upon the product. (See chart below)
- Accessories carry a limited warranty of one year from the date of receipt.
- Consumable items are defined as expendable parts or accessories expected to become inoperable within a reasonable amount of use and are covered by a 90 day limited warranty against manufacturer's defects.

Who is Covered

This warranty covers only the initial purchaser of the product from the date of delivery.

What is Covered

This warranty covers any defects in workmanship or materials subject to the limitations stated below. This warranty does not cover failures due directly or indirectly to misuse, abuse, negligence or accidents, normal wear-and-tear, improper repair, alterations or lack of maintenance. JET woodworking machinery is designed to be used with Wood. Use of these machines in the processing of metal, plastics, or other materials outside recommended guidelines may void the warranty. The exceptions are acrylics and other natural items that are made specifically for wood turning.

Warranty Limitations

Woodworking products with a Five Year Warranty that are used for commercial or industrial purposes default to a Two Year Warranty. Please contact Technical Service at 1-800-274-6846 for further clarification.

How to Get Technical Support

Please contact Technical Service by calling 1-800-274-6846. **Please note that you will be asked to provide proof of initial purchase when calling.** If a product requires further inspection, the Technical Service representative will explain and assist with any additional action needed. JET has Authorized Service Centers located throughout the United States. For the name of an Authorized Service Center in your area call 1-800-274-6846 or use the Service Center Locator on the JET website.

More Information

JET is constantly adding new products. For complete, up-to-date product information, check with your local distributor or visit the JET website.

How State Law Applies

This warranty gives you specific legal rights, subject to applicable state law.

Limitations on This Warranty

JET LIMITS ALL IMPLIED WARRANTIES TO THE PERIOD OF THE LIMITED WARRANTY FOR EACH PRODUCT. EXCEPT AS STATED HEREIN, ANY IMPLIED WARRANTIES OF MERCHANTABILITY AND FITNESS FOR A PARTICULAR PURPOSE ARE EXCLUDED. SOME STATES DO NOT ALLOW LIMITATIONS ON HOW LONG AN IMPLIED WARRANTY LASTS, SO THE ABOVE LIMITATION MAY NOT APPLY TO YOU.

JET SHALL IN NO EVENT BE LIABLE FOR DEATH, INJURIES TO PERSONS OR PROPERTY, OR FOR INCIDENTAL, CONTINGENT, SPECIAL, OR CONSEQUENTIAL DAMAGES ARISING FROM THE USE OF OUR PRODUCTS. SOME STATES DO NOT ALLOW THE EXCLUSION OR LIMITATION OF INCIDENTAL OR CONSEQUENTIAL DAMAGES, SO THE ABOVE LIMITATION OR EXCLUSION MAY NOT APPLY TO YOU.

JET sells through distributors only. The specifications listed in JET printed materials and on official JET website are given as general information and are not binding. JET reserves the right to effect at any time, without prior notice, those alterations to parts, fittings, and accessory equipment which they may deem necessary for any reason whatsoever. JET® branded products are not sold in Canada by JPW Industries, Inc.

Product Listing with Warranty Period

90 Days – Parts; Consumable items
1 Year – Motors; Machine Accessories
2 Year – Metalworking Machinery; Electric Hoists, Electric Hoist Accessories; Woodworking Machinery used for industrial or commercial purposes
5 Year – Woodworking Machinery
Limited Lifetime – JET Parallel clamps; VOLT Series Electric Hoists; Manual Hoists; Manual Hoist Accessories; Shop Tools; Warehouse & Dock products; Hand Tools; Air Tools

NOTE: JET is a division of JPW Industries, Inc. References in this document to JET also apply to JPW Industries, Inc., or any of its successors in interest to the JET brand.

Table of Contents

Warranty and Service.....	2
Table of Contents.....	3
Warning.....	4
Introduction	6
Specifications	6
Unpacking	7
Contents of the Shipping Container	7
Assembly.....	7
Adjusting the Head Height.....	8
Adjusting the Rack Assembly.....	8
Controls.....	9
Control Panel for GHD-20T/20PFT	10
Electrical Connections.....	10
Adjustments	11
Installing a Drill Chuck (not included)	11
Removing the Arbor	11
Adjusting the Depth Stop for Drilling (GHD-20).....	11
Adjusting Depth Stop for Drilling and Tapping (GHD-20T).....	11
Adjusting the Depth Stop for Drilling (GHD-20PF)	12
Adjusting the Depth Stop for Drilling (GHD-20PFT)	12
Adjusting the Depth Stop for Tapping (GHD-20PFT)	12
Changing Spindle Speeds.....	12
Return Spring Adjustment	13
Tilting the Head	13
Lubrication.....	13
Changing the Gear Box Lubricant	14
Replacement Parts.....	16
GHD-20PF/20PFT Head Assembly.....	17
Parts List – GHD-20PF/20PFT Head Assembly.....	18
GHD-20/20T Head Assembly	21
Parts List – GHD-20/20T Head Assembly.....	22
Gear Assembly GHD-20PF, 20PFT	24
Parts List – Gear Assembly GHD-20PF, 20PFT	25
Gear Assembly GHD-20/20T	26
Parts List – Gear Assembly GHD-20/20T	27
Base, Table and Column Assembly (all models).....	28
Parts List – Base, Table and Column Assembly (all models).....	29
Control Box Assembly (all models)	30
Parts List – Control Box Assembly	31
Electrical Panel Components (GHD-20PFT).....	32
Parts List – Electrical Panel Components (GHD-20PFT).....	33
Electrical Schematic (GHD-20/20PF only)	34
Electrical Schematic (GHD-20PFT).....	35
Electrical Schematic (GHD-20T)	36



Warnings

1. Read and understand the entire owner's manual before attempting assembly or operation.
2. Read and understand the warnings posted on the machine and in this manual. Failure to comply with all of these warnings may cause serious injury.
3. Replace the warning labels if they become obscured or removed.
4. This drill press is designed and intended for use by properly trained and experienced personnel only. If you are not familiar with the proper and safe operation of a drill press, do not use until proper training and knowledge have been obtained.
5. Do not use this drill press for other than its intended use. If used for other purposes, JET disclaims any real or implied warranty and holds itself harmless from any injury that may result from that use.
6. Do not use this machine in damp or wet locations, or expose it to rain. Keep work area well lighted.
7. Always wear approved safety glasses/face shields while using this drill press. (Everyday eyeglasses only have impact resistant lenses; they are not safety glasses.)
8. Before operating this drill press, remove tie, rings, watches and other jewelry, and roll sleeves up past the elbows. Remove all loose clothing and confine long hair. Non-slip footwear or anti-skid floor strips are recommended. Do **not** wear gloves.
9. Wear ear protectors (plugs or muffs) during extended periods of operation.
10. CALIFORNIA PROPOSITION 65 WARNING: This product contains chemicals known to the State of California to cause cancer, or birth defects or other reproductive harm.
11. This product, when used for welding, cutting, or working with metal, produces fumes, gases, or dusts which contain chemicals known to the State of California to cause birth defects and, in some cases, cancer. (California Health and Safety Code Section 25249.5 et seq.)
12. Do not operate this machine while tired or under the influence of drugs, alcohol or any medication.
13. Make certain the switch is in the **OFF** position before connecting the machine to the power supply.
14. Clamp the workpiece or brace it against the column to prevent rotation.
15. Use the recommended speed for drill accessories and workpiece materials.
16. Make certain the machine is properly grounded.
17. Make all machine adjustments or maintenance with the machine unplugged from the power source.
18. Remove adjusting keys and wrenches. Form a habit of checking to see that keys and adjusting wrenches are removed from the machine before turning it on.
19. Keep safety guards in place at all times when the machine is in use. If removed for maintenance purposes, use extreme caution and replace the guards immediately after maintenance is complete.
20. Check damaged parts. Before further use of the machine, a guard or other part that is damaged should be carefully checked to determine that it will operate properly and perform its intended function. Check for alignment of moving parts, binding of moving parts, breakage of parts, mounting and any other conditions that may affect its operation. A guard or other part that is damaged should be properly repaired or replaced.
21. Provide for adequate space surrounding work area and non-glare, overhead lighting.
22. Keep the floor around the machine clean and free of scrap material, oil and grease.
23. Keep visitors a safe distance from the work area. **Keep children away.**
24. Make your workshop child proof with padlocks, master switches or by removing starter keys.
25. Give your work undivided attention. Looking around, carrying on a conversation and "horse-play" are careless acts that can result in serious injury.
26. Maintain a balanced stance at all times so that you do not fall or lean against the rotating spindle or other moving parts. Do not overreach or use excessive force to perform any machine operation.



Warnings

27. Use the right tool at the correct speed and feed rate. Do not force a tool or attachment to do a job for which it was not designed. The right tool will do the job better and more safely.
28. Use recommended accessories; improper accessories may be hazardous.
29. Maintain tools with care. Keep cutting tools sharp and clean for the best and safest performance. Follow instructions for lubricating and changing accessories.
30. Make sure the workpiece is securely attached or clamped to the table. Never use your hand to hold the work piece.
31. Turn off the machine and disconnect from power before cleaning. Use a brush or compressed air to remove chips or debris — do not use your hands.
32. Do not stand on the machine. Serious injury could occur if the machine tips over.
33. Never leave the machine running unattended. Turn the power off and do not leave the machine until it comes to a complete stop.
34. Remove loose items and unnecessary work pieces from the area before starting the machine.

Familiarize yourself with the following safety notices used in this manual:

CAUTION This means that if precautions are not heeded, it may result in minor injury and/or possible machine damage.

WARNING This means that if precautions are not heeded, it may result in serious or even fatal injury.

- - SAVE THESE INSTRUCTIONS - -

Introduction

This manual is provided by JET covering the safe operation and maintenance procedures for JET Model GHD-20 Series Drill Presses. This manual contains instructions on installation, safety precautions, general operating procedures, maintenance instructions and parts breakdown. This machine has been designed and constructed to provide consistent, long-term operation if used in accordance with instructions set forth in this manual. If there are any questions or comments, please contact either your local supplier or JET. JET can also be reached at our web site: www.jettools.com.

Specifications

Model Number	GHD-20	GHD-20PF	GHD-20T	GHD-20PFT
Stock Number	354020	354024	354022	354026
Drilling Capacity – Cast Iron (in.)	1-1/2	1-1/2	1-1/2	1-1/2
Drilling Capacity – Mild Steel (in.)	1-1/4	1-1/4	1-1/4	1-1/4
Column Diameter (in.)	4-1/2	4-1/2	4-1/2	4-1/2
Quill Diameter (in.)	3	3	3	3
Swing (in.)	20	20	20	20
Number of Spindle Speeds	12	12	12	12
Range of Spindle Speeds (RPM)	[all models] Low: 60/130/230/450/800/1500; High: 120/260/460/900/1600/3000			
Number of Power Downfeeds	n/a	3	n/a	3
Range of Power Downfeeds	n/a...0.004, 0.007, 0.01n/a ...0.004, 0.007, 0.01			
Spindle Taper	MT-3	MT-3	MT-3	MT-3
Spindle Travel, manual (in.)	5	4-1/2	5	4-1/2
Spindle Travel, powerfeed (in.)	n/a	4-1/4	n/a	4-1/4
Maximum Distance Spindle to Table (in.)	30-1/2	30-1/2	30-1/2	30-1/2
Maximum Distance Spindle To Base (in.)	44-5/16	44-5/16	44-5/16	44-5/16
Table Size (in.)	21-3/4 x 19-1/2	21-3/4 x 19-1/2	21-3/4 x 19-1/2	21-3/4 x 19-1/2
Table Travel (in.)	25-1/2	25-1/2	25-1/2	25-1/2
Table T-Slots	2	2	2	2
Table T-Slot Size (in.)	5/8	5/8	5/8	5/8
Table T-Slot Centers (in.)	9	9	9	9
Work Table Weight Capacity (lbs.)	275	275	275	275
Base Dimensions LxWxH (in.)	26 x 18 x 5	26 x 18 x 5	26 x 18 x 5	26 x 18 x 5
Base Work Table (in.)	15-1/4 x 13	15-1/4 x 13	15-1/4 x 13	15-1/4 x 13
Base T-Slots	2	2	2	2
Base T-Slot Size (in.)	5/8	5/8	5/8	5/8
Motor	[all models] TEFC 2HP, 3PH, 230V only, 60Hz, 2-speed			
Overall Dimensions LxWxH (in.)	32 x 24 x 71	32 x 24 x 71	32 x 24 x 71	32 x 24 x 71
Net Weight (lbs.)	660	660	700	700

The above specifications were current at the time this manual was published, but because of our policy of continuous improvement, JET reserves the right to change specifications at any time and without prior notice, without incurring obligations.

Unpacking

Contents of the Shipping Container

- 1 Gear Head Drill Press
- 1 Lug Wrench
- 1 Can of Gray Touch-Up Paint
- 1 Drill Chuck Arbor (MT-3 x JT-6)
- 1 Drawbar
- 1 Drift Key
- 1 Crank
- 1 Handle
- 3 Downfeed Handles (GHD-20/20T only)
- 3 Knobs (two with GHD-20PF/20PFT)
- 1 3mm Hex Wrench
- 1 4mm Hex Wrench
- 1 5mm Hex Wrench
- 1 Main Shaft Cover
- 1 Owner's Manual
- 1 Warranty Card

1. Finish removing the contents of the shipping container.
2. Compare the contents of the shipping container with the list above. Report any shortages or damage to your JET distributor.
3. Clean all rust protected surfaces with kerosene or a light solvent. Do **not** use lacquer thinner, paint thinner or gasoline. These will damage plastic components and painted surfaces.

Assembly

1. Slide crank (A, Figure 1) onto the table raising assembly shaft.
2. Tighten the set screw (B, Figure 1) to hold the crank in place
3. Install the handle (C, Figure 1) onto the crank
4. For the GHD-20/20T, install three handles with knobs (A, Figure 2) into the downfeed hub. For the GHD-20PF/20PFT, screw two knobs onto the handles of the power downfeed assembly.
5. Install chuck guard by sliding the support bar up into the base mounted to the head. Tighten screws.

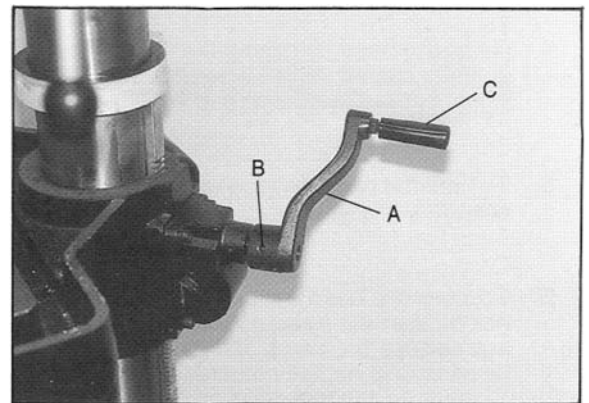

Figure 1

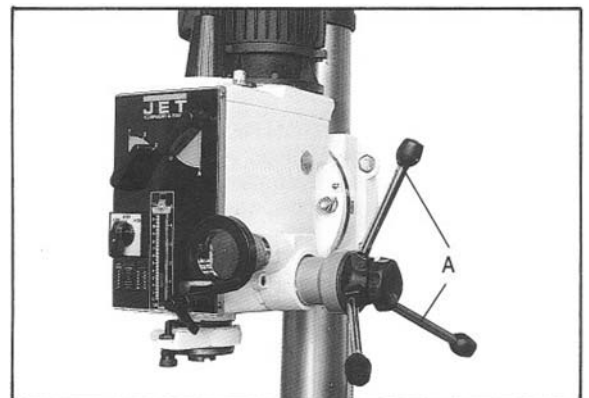

Figure 2

Adjusting the Head Height

To facilitate shipping, the Drill Press is packed with the head adjusted down on the column. The head assembly should be moved to the top of the column before drilling operation starts.

⚠WARNING The head assembly is very heavy. Use caution when adjusting the head and make sure it is supported by the table or locked in place. Failure to comply may cause damage to property and/or personal injury!

1. Unlock the table by loosening the handle (A, Figure 3)
2. Lower the table until there is room to place a block of wood between the table and the head assembly (Figure 4).
3. Loosen two nuts (A, Figure 5) on the head assembly.
4. Raise the head by raising the table. The head is at the correct height when the top of the head is just below the column cap (B, Figure 5).
5. Tighten the two nuts (A, Figure 5) on the head assembly firmly.
6. To lower the head, reverse the steps above. **Do not loosen the head assembly bolts without supporting the head. This may cause the head to slip on the column and may cause damage to the machine or personal injury.**

Adjusting the Rack Assembly

After the table has been adjusted, the rack assembly will need to be raised.

⚠CAUTION The table must be locked when raising the rack. Failure to lock the table may cause the assembly to drop on the column, causing damage to the machine.

1. Make sure both head assembly nuts (A, Figure 5) are tight.
2. Loosen the hex socket cap screw (C, Figure 6) on the upper rack ring.
3. Loosen two set screws on the bottom rack ring (D, Figure 7).
4. Raise the rack assembly by turning the table raising handle clockwise.
5. The rack assembly is at its full height when the top rack ring is just below the head assembly (as illustrated in Figure 6).
6. Tighten the hex socket cap screw on the top rack ring and two set screws on the lower rack ring.

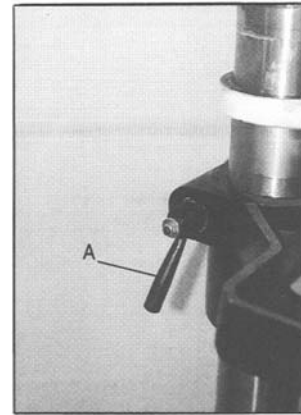

Figure 3

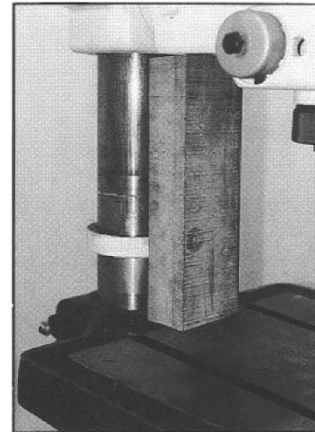

Figure 4

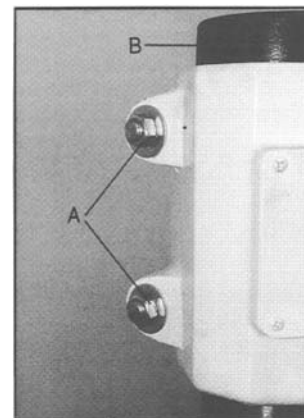

Figure 5

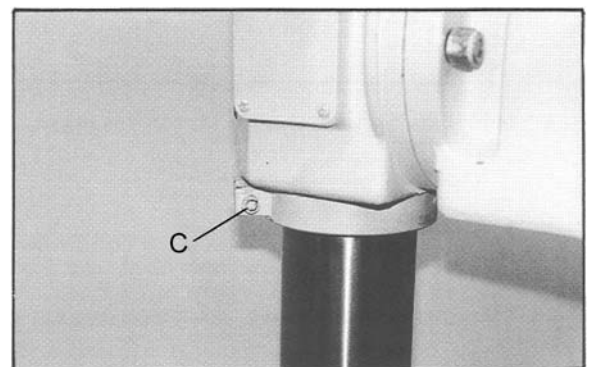

Figure 6

Controls

Low/Off/High Switch (A, Figure 8) – located top left side of the head assembly. Switch between low and high speed range. In the stop position, the spindle is stopped, but the machine still has power.

Fine Feed Handwheel (B, Figure 8) – located on the front lower right of the head assembly. Turn clockwise to lower the quill. Turn counter-clockwise to raise the quill.

Quill Lock (C, Figure 8) – located on the front lower right of the head assembly. Turn clockwise and tighten to lock the quill. Turn counterclockwise and loosen to unlock the quill.

Speed Selectors (D, Figure 8) – located on the top front of the head assembly. Used with low/off/high switch and the speed chart on the front of the head assembly to set the drill to a specific speed. **Caution: Change speeds only when the machine is stopped.**

Depth Stop (GHD-20/20T) (E, Figure 8) - located on the front bottom of the head assembly. When set, the quill will only advance to a certain depth.

Depth Stop (GHD-20PF/20PFT) (A, Figure 9) - located on the downfeed assembly on the right side of the head assembly. When set, the quill will advance automatically or manually to a certain depth.

Power Downfeed Speed Selector (GHD-20PF/ 20PFT) (B, Figure 9) - located on the right side of the head assembly. Set to advance the quill at desired speed. Engage the power downfeed by pulling the handle assembly away from the head. Disengage the power downfeed by pushing the handle assembly toward the head. Tighten Lock Screw (C, Figure 9) to lock out the power downfeed and to keep the drill in manual feed only.

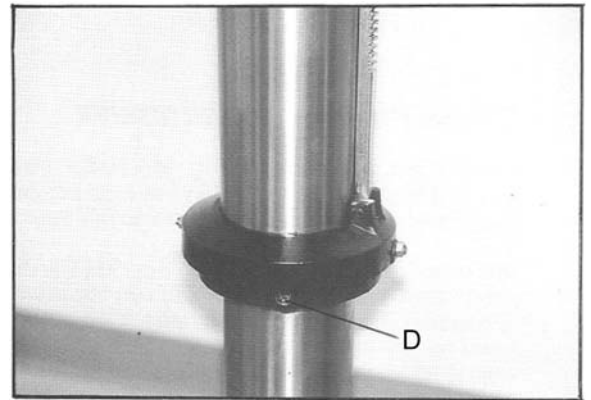

Figure 7

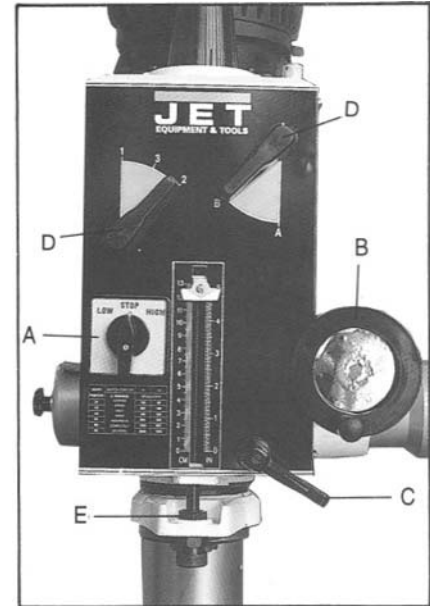

Figure 8

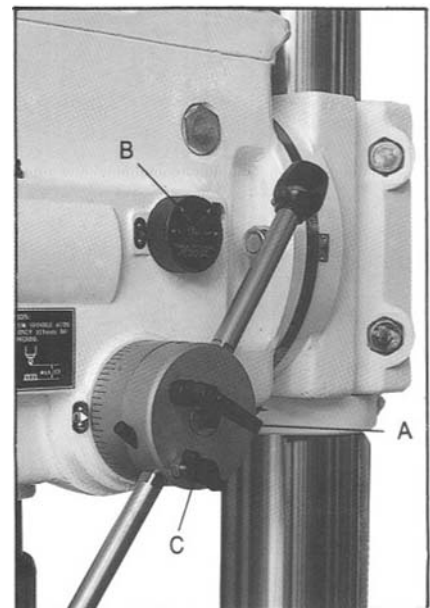

Figure 9

Control Panel for GHD-20T/20PFT

Low/Off/High Switch (A, Figure 9A) Switch between low and high speed range. In the stop position, the spindle is stopped, but the machine still has power.

Drilling Tapping Selector (B, Figure 9A) For drilling, press the start switch (F, Figure 9A) to run the machine. **Caution:** The internal depth stop (GHD-20PFT) is used only with the tapping function. Raise the adjusting knob (B, Figure 11) to the top of the depth stop screw so as not to interfere with power downfeed or manual feeding operations. For tapping, turn switch (B, Figure 9A) to tapping position, press down the handle. The quill functions when upper limit switch is released. It then reverses automatically after hitting lower limit switch and will not stop until it hits the upper limit switch.

Emergency Switch (C, Figure 9A) Press this switch to stop all operations.

Power Light (D, Figure 9A) Indicates power is on.

Reverse Switch (E, Figure 9A) If tapping is interrupted press the reverse switch to reverse the tap from workpiece. The button must be held down for continuous reversing.

Start Switch (F, Figure 9A) Activates the motor in the drill or tap mode.

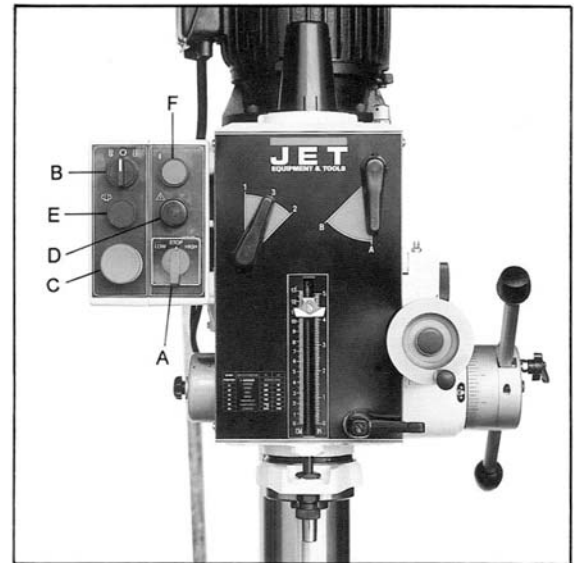

Figure 9A

Electrical Connections

⚠WARNING Electrical connections must be made by a qualified electrician in compliance with all relevant codes. This machine must be properly grounded to help prevent electrical shock and possible fatal injury. All adjustments or repairs must be done with the drill disconnected from the power source.

The motor is rated at 2 HP, 3 PH, 230V only. Make sure the power available matches the power requirement of the drill. The drill must be properly grounded.

When the drill is connected properly, the spindle turns clockwise in a conventional drilling rotation. If the spindle does not turn clockwise, disconnect the drill from the power supply and reverse two of the three power leads.

Adjustments

Installing a Drill Chuck (not included)

1. Disconnect the machine from the power source.
2. Clean the arbor and the inside of the chuck. The tapers must be clean and dry.
3. Push the chuck onto the arbor.
4. Retract the chuck jaws completely, and push the arbor into the spindle.
5. Use a rubber mallet, or steel face hammer against a block of wood, to sharply tap the bottom of the chuck two or three times to seat it. (Note: Never use a steel face hammer directly against the chuck.)

Removing the Arbor

1. Unplug the machine from the power source.
2. Make sure the drill is in gear.
3. Remove the main shaft cover (A, Figure 11).
4. Use an adjustable wrench or box wrench to loosen the draw bar (A, Figure 10).
5. Unscrew the draw bar approximately two revolutions. If the arbor is not loose, gently tap on top of the draw bar to loosen the arbor.
6. Continue to unscrew the draw bar with one hand on the chuck and arbor so that it doesn't drop onto the table.

Adjusting the Depth Stop for Drilling (GHD-20)

To drill multiple holes at the same preset depth, use the depth stop:

1. Turn the adjusting knob (B, Figure 11) until the correct depth is indicated on the scale on the front of the drill head.
2. Drill several test holes to make sure the depth stop is set correctly.

Adjusting Depth Stop for Drilling and Tapping (GHD-20T)

1. Follow steps for GHD-20 drilling.
2. When the tapping switch is on, the limit switches are active and will reverse rotation at the bottom of the stroke and stop rotation at the top.
3. When the tapping switch is off, the limit switches are inactive and do not effect spindle rotation.

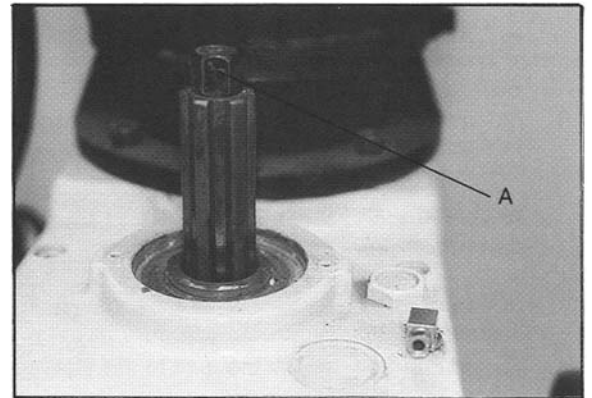

Figure 10

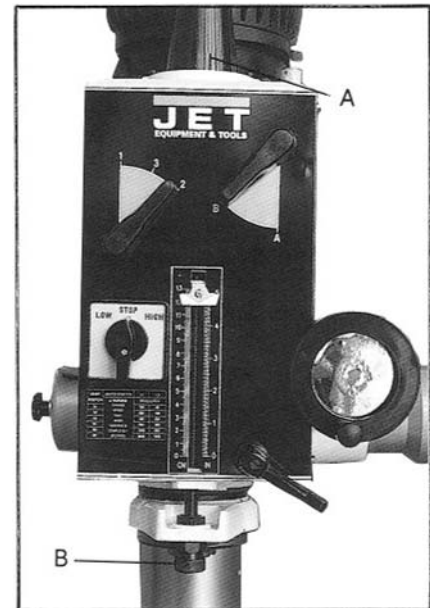

Figure 11

Adjusting the Depth Stop for Drilling (GHD-20PF)

1. Loosen the depth stop lock handle (A, Figure 12).
2. Manually advance the quill to the desired depth with one hand.
3. With the other hand, turn the depth stop scale (B, Figure 12) counter-clockwise to zero.
4. Tighten the depth stop lock handle (A, Figure 12). The depth stop will now stop the drill at the pre-determined setting.

Adjusting the Depth Stop for Drilling (GHD-20PFT)

1. Turn the adjusting knob (B, Figure 11) until full travel is possible. Do not use this scale as a reference when drilling. This depth stop is for tapping only and should not interfere with drilling operations.
2. Follow steps for GHD-20PF drilling.

Adjusting the Depth Stop for Tapping (GHD-20PFT)

1. Loosen the depth stop lock handle (A, Figure 12) so that it does not interfere with the internal depth stop located on the front of the drill head.
2. Adjust the front depth stop for the proper depth.
3. Manually advance the quill releasing the upper limit switch for tapping. This will start the motor. The quill will reverse directions upon triggering the lower limit switch.
4. **Do not** powerfeed and tap at the same time.

Changing Spindle Speeds

To change spindle speeds:

1. Stop the drill by turning the low/stop/high switch to stop.
2. Adjust the levers (A, Figure 13) to the desired speed as indicated by the speed chart. Turning the spindle by hand will help the gear teeth mesh.

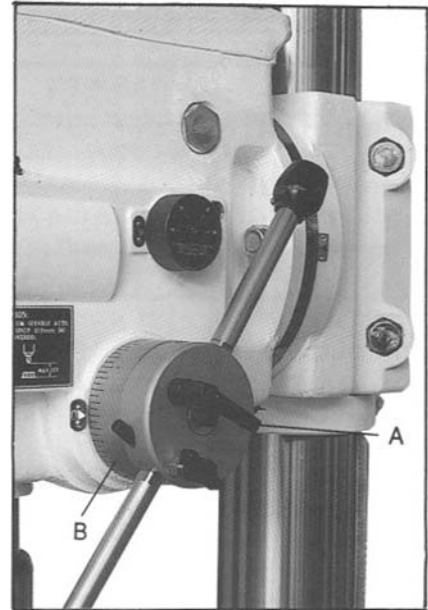

Figure 12

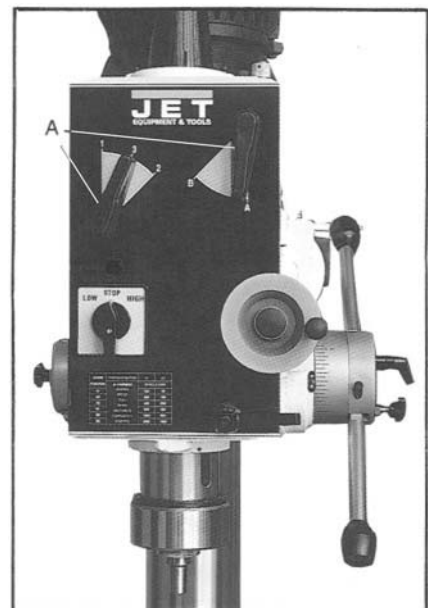

Figure 13

Return Spring Adjustment

The return spring is adjusted at the factory and should not need further adjustment. If adjustment ever becomes necessary:

1. Unplug the machine from the power source.
2. Loosen lock knob (A, Figure 14) while holding the quill spring cover. Do not allow the cover to turn in your hand or the spring will unwind.
3. Pull out the cover (B, Figure 14) and rotate until the pin (C, Figure 14) on the return spring plate engages the next notch in the coil spring cover. Turn the cover clockwise to decrease tension and counter-clockwise to increase tension.
4. Tighten the lock knob (A, Figure 14). Do not over-tighten. Nuts should not contact the housing when tight.

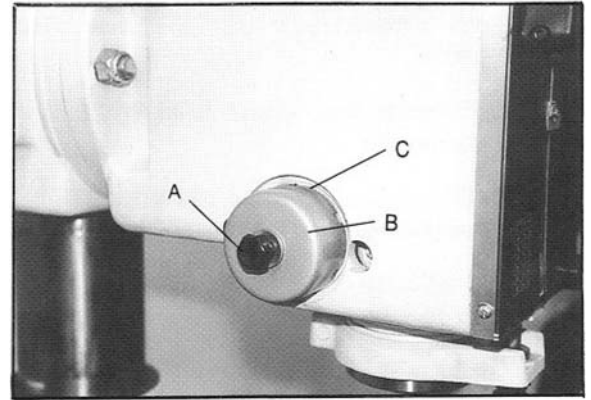

Figure 14

Tilting the Head

To tilt the head:

1. Turn nut (A, Figure 15) clockwise to pull out the alignment pin (B, Figure 15).
2. Loosen hex nuts (C, Figure 15).
3. Tilt the head to the desired angle.
4. Tighten two hex nuts (C, Figure 15).
5. The alignment pin only works at 0° and must be reinserted when the head is returned to 0°.

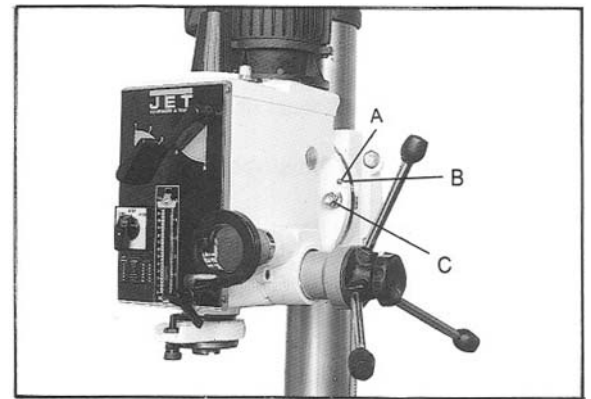

Figure 15

Lubrication

Refer to Figure 16.

1. **Headstock.** Fill with Mobil DTE® Oil Heavy Medium. Check level daily and change yearly.
2. **Powerfeed.** Use Mobilith AW2 every three months.
3. **Spline Drive.** Use Mobilith AW2 every three months.
4. **Quill Pinion Gear.** Use Mobilith AW2 Every three months.
5. **Quill Column Surface.** Use Mobil DTE® Oil Heavy Medium every three months.
6. **Table Pinion Gear.** Use Mobilith AW2 every three months.
7. **Quill Return Spring.** Mobil DTE® Oil Heavy Medium every month. **Do not remove cover.**

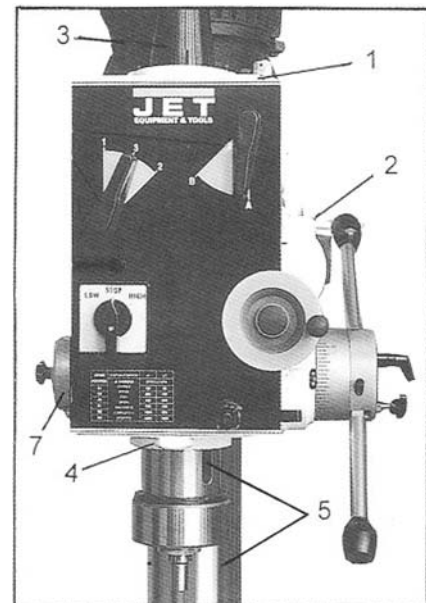

Figure 16

Changing the Gear Box Lubricant

1. Disconnect the machine from the power source.
2. Loosen nuts (A, Figure 17).
3. Tilt the head to access the drain plug. The drain plug is found in the head cavity behind the spindle.
4. Loosen the drain plug but do not remove.
5. Return the head to upright position.
6. Place a container on the table to catch the draining lubricant.
7. Remove the filler plug (A, Figure 18).
8. Remove the drain plug.
9. Replace the drain plug after the lubricant has finished draining.
10. Pour one (1) gallon of new lubricant (SHC-634 Oil Heavy Medium) through the filler hole. **Caution: Use of any other type of lubricant other than that specified may cause damage to the drill press.**
11. Replace the filler plug.

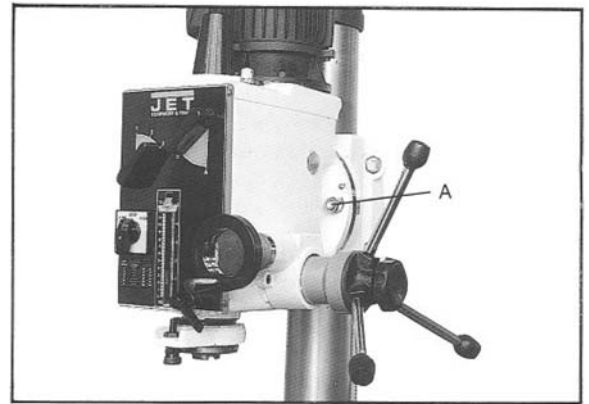

Figure 17

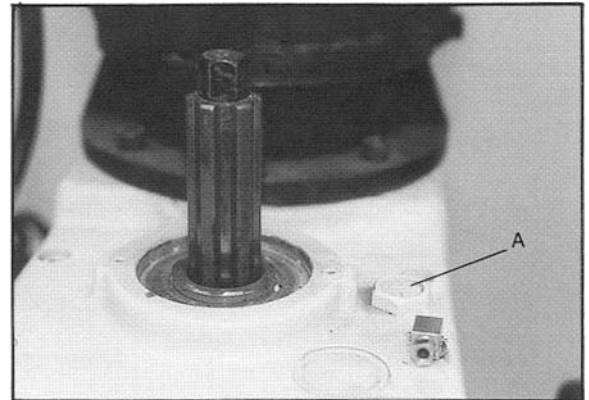

Figure 18

Troubleshooting GHD-20 series Drill Presses

Trouble	Probable Cause	Remedy
Excessive vibration.	Motor out of balance.	Balance motor or replace.
Noisy Operation.	Improper quill adjustment.	Adjust quill.
	Dry spindle.	Lubricate spindle. See the <i>Lubrication</i> section.
	Noisy motor	Check motor bearings or for a loose motor fan.
Motor Stalls.	Overfeeding.	Reduce feed rate.
	Dull drill bit.	Sharpen drill bit.
	Motor not running up to speed.	Replace or repair motor. Check fuses in all three legs on three phase motors and replace, if necessary.
Drill or tool heats up or burns work.	Excessive speed.	Reduce speed.
	Dull tool.	Sharpen tool or replace.
	Feed rate too slow.	Increase feed enough to clear chips.
	Rotation of drill incorrect.	Reverse motor rotation.
	Failure to use cutting oil or coolant (on steel).	Use cutting oil or coolant (on steel).
Drill leads off.	No drill spot.	Center punch or center drill workpiece.
	Cutting lips on drill off center.	Re-grind drill.
	Quill loose in head.	Tighten quill.
	Bearing play.	Reseat or replace bearings.
Excessive drill runout or wobble.	Bent drill.	Replace drill.
	Bearing play.	Reseat or replace bearings.
	Drill not seated properly in the chuck.	Loosen, reset, and tighten chuck.
Work or fixture comes loose or spins.	Failure to clamp work piece or work holding device to table.	Clamp work piece or work holding device to the table surface.

Replacement Parts

Replacement parts are listed on the following pages. To order parts or reach our service department, call 1-800-274-6848 Monday through Friday, 8:00 a.m. to 5:00 p.m. CST. Having the Model Number and Serial Number of your machine available when you call will allow us to serve you quickly and accurately.

Non-proprietary parts, such as fasteners, can be found at local hardware stores, or may be ordered from JET.

Some parts are shown for reference only, and may not be available individually.

GHD-20PF/20PFT Head Assembly

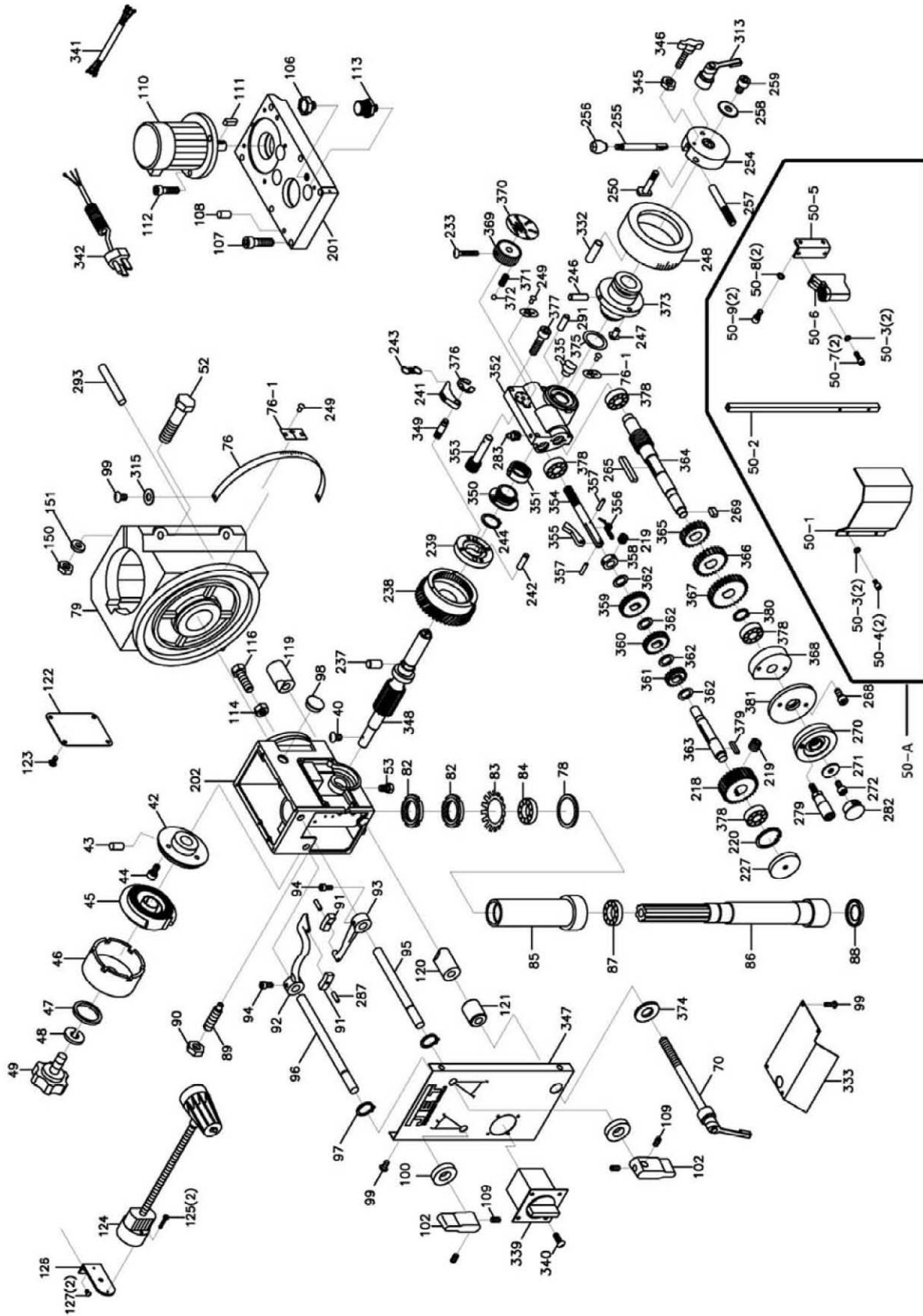

Parts List – GHD-20PF/20PFT Head Assembly

Index No.	Part No.	Description	Size	Qty
40	GHD20PF-40	Screw	3/16" x 3/8"	1
42	61105	Spring Base		1
43	GHD20PF-43	Spring Pin	3 x 12 mm	2
44	GHD20PF-44	Screw	3/16" x 3/4"	3
45	61104	Spring		1
46	61103	Spring Cover		1
47	TS-0680021	Washer	1/4"	1
48	TS-0720071	Lock Washer	1/4"	1
49	6185	Lock Knob		1
50-A	GHD20-50-A	Chuck Guard Assembly (#50-1 thru 50-9)		1
50-1	JMD18-125-1	Chuck Guard		1
50-2	JMD18-125-2	Chuck Guard Supporting Rod		1
50-3	TS-2361051	Spring Washer	M5	4
50-4	TS-1502021	Hex Socket Head Screw	M5 x 10	2
50-5	GHD20-50-5	Chuck Guard Bracket		1
50-6	JMD18-125-5	Rotary Supporting Base		1
50-7	JMD18-125-6	Hex Socket Cap Screw	M5x15L	2
50-8	TS-1551041	Spring Washer	M6	2
50-9	6286490	Hex Socket Cap Screw	M6x15L	2
52	TS-0071141	Hex Cap Bolt	5/8" x 5-1/2"	2
53	GHD20-53	Oil Plug	1/4"PT	1
70	2421003	Handle Rod		1
76	2401076	Scale		1
76-1	2450060	Pointer		3
78	6112	Rubber Gasket		1
79	2412001G	Casting		1
82	6114	Lock Nut		1
83	GHD20PF-83	Star Washer		1
84	BB-30206	Taper Roller Bearing		1
85	6116	Rack Sleeve	MT3	1
86	6117	Spindle Shaft		1
87	BB-30207	Taper Roller Bearing		1
88	6119	Bearing Cap		1
89	6127	Screw Key		1
90	TS-0561031	Hex Nut	3/8"	1
91	2401066	Gear Lever Bracket		2
92	2401067	Gear Lever (Left)		1
93	2401068	Gear Lever (Right)		1
94	GHD20PF-94	Screw	1/4" x 1/2"	1
95	2401070	Lever Shaft (Right)		1
96	2401071	Lever Shaft (Left)		1
97	GHD20PF-97	C-Ring		2
98	GHD20PF-98	Oil Sight Glass		1
99	GHD20PF-99	Screw	3/16" x 3/8"	8
100	GHD20PF-100	Oil Seal	G12	2
102	2401075	Speed Lever		2
106	GHD20PF-106	Oil Plug		1
107	TS-0209081	Hex Socket Cap Screw	3/8" x 3/4"	6
108	GHD20PF-108	Miter Pin		2
109	TS-0267021	Set Screw	1/4" x 1/4"	4
110	GHD20-86	Motor	2HP 3PH 230V	1
111	GHD20PF-111	Key	6 x 5 x 30mm	1
112	TS-0209051	Hex Socket Cap Screw	3/8" x 3/4"	6
113	GHD20-89	Brass Fitting		1
114	TS-0561071	Hex Nut	5/8"	3
116	TS-0071041	Hex Cap Bolt	5/8" x 2-1/4"	3
119	6126-1	Collar (thread)		1
120	6125-1	Collar		1
121	6125-2	Collar		1
122	61112	Cover Plate		1

Index No.	Part No.	Description	Size	Qty
123	GHD20-123	Screw		4
124	GHD20-124	Lamp Assembly		1
125	TS-2284352	Pan Head Screw	M4x35L	2
126	GHD20-126	Lamp Base		1
127	TS-1503031	Hex Socket Cap Screw	M6x12L	2
150	TS-0561071	Hex Nut	5/8"	2
151	TS-0680081	Washer	5/8"	2
201	2450001G	Head Body Cover		1
202	2450002G	Head Body Casting		1
218	2450008	Worm Gear		1
219	TS-1523011	Set Screw	M6 x 6	4
220	GHD20PF-220	C-Ring		4
227	2450014	Cover		1
233	GHD20PF-233	Screw	M4 x 25	1
235	2450020	Release Block		1
236	2450021	Small Pinion Shaft		1
237	2450022	Key		2
238	2450023	Worm Gear		1
239	2450024	Clutch Key Base		1
241	2450026	Clutch Key		2
242	2450027	Spring Pin		2
243	2450028	Spring		2
244	GHD20PF-244	C-Ring		1
246	2450030	Bushing Pin		1
247	2450031	Bushing Stop		1
248	2450032	Scale Base		1
249	GHD20PF-249	Rivet		8
250	2450033	Scale Base Set Screw		1
254	2450037	Handle Body		1
255	2450038	Handle Rod		2
	2450038N	Handle Rod (serial #16031665 and higher)		2
256	GHD20PF-256	Knob		2
257	2450039	Handle Rod Pin		2
258	2450040	Washer		1
259	TS-1504021	Hex Socket Cap Screw	M8 x 12	1
265	GHD20PF-265	Key	5 x 5 x 32mm	1
266	2450045	Cover		1
268	TS-1502031	Hex Socket Cap Screw	M5 x 12	2
269	GHD20PF-269	Key	4 x 4 x 10mm	1
270	24500470	Handwheel		1
271	GHD20PF-271	Washer		1
272	TS-1523031	Hex Socket Cap Screw	M6 x 12	1
279	TS-0561021	Hex Nut	5/16"	1
282	GHD20PF-282	Plug	7/8"	1
283	GHD20PF-283	Oil Seal		1
287	GHD20PF-287	Spring Pin		2
291	2450051	Pin		1
313	2450063	Grip		1
315	GHD20PF-315	Washer	3/16"	2
330	2401085	Dust Plate		1
332	GHD20PF-332	Pin		1
333	2450069	Dust Plate		1
339	GHD20-339	High-Low Switch (for GHD20PF only)		1
340	GHD20-340	Screw (GHD-20PF only)		1
341	GHD20-341	Motor Cord		1
342	GHD20-342	Power Cord		1
345	GHD20PF-345	Nut		1
346	GHD20PF-346	Manual Feed Knob		1
347	GHD20-347	Name Plate		1
347-1	GHD20PF-347-1	Name Plate (for GHD20PFT only - not shown)		1
348	2450086A	Pinion Shaft		1
349	2450097	Spring Pin		2

Index No.	Part No.	Description	Size	Qty
350	2450096	Clutch Screw		1
351	2450095	Clutch Nut		1
352	2450068G	Gear Box		1
353	2450081A	Gear Shaft		1
354	2450082A	Speed Change Lever		1
355	2450083A	Stop		1
356	2450084A	Spring Leaf		1
357	GHD20PF-357	Pin		2
358	2450089A	Bushing Bracket		1
359	2450072A	Bearing Bushing		1
360	2450071A	Bearing Bushing		1
361	2450070A	Bearing Bushing		1
362	2450074A	Washer		4
363	2450073A	Shaft		1
364	2450078A	Transmission Worm		1
365	2450075A	Bearing Bushing		1
366	2450076A	Bearing Bushing		1
367	2450077A	Bearing Bushing		1
368	2450085A	Spacer Ring		1
369	2450079	Speed Lever		1
370	GHD20PF-370	Speed Scale		1
371	290089	Spring		1
372	GHD20PF-372	Steel Ball		1
373	2450087A	Clutch Bushing		1
374	GHD20-374	Flat Washer	1/2" x 7/8" x 2"	1
375	2450100	Washer		1
376	GHD20PF-376	E-Retainer Ring	E5	2
377	GHD20PF-377	Hex Socket Head Screw	5/16" x 1-1/4"L	4
378	CA6003ZZ	Ball Bearing		4
379	GHD20PF-379	Key	5 x 5 x 28L mm	1
380	GHD20PF-380	C-Ring		1
381	2450088A	Graduated Bottom Ring		1

GHD-20/20T Head Assembly

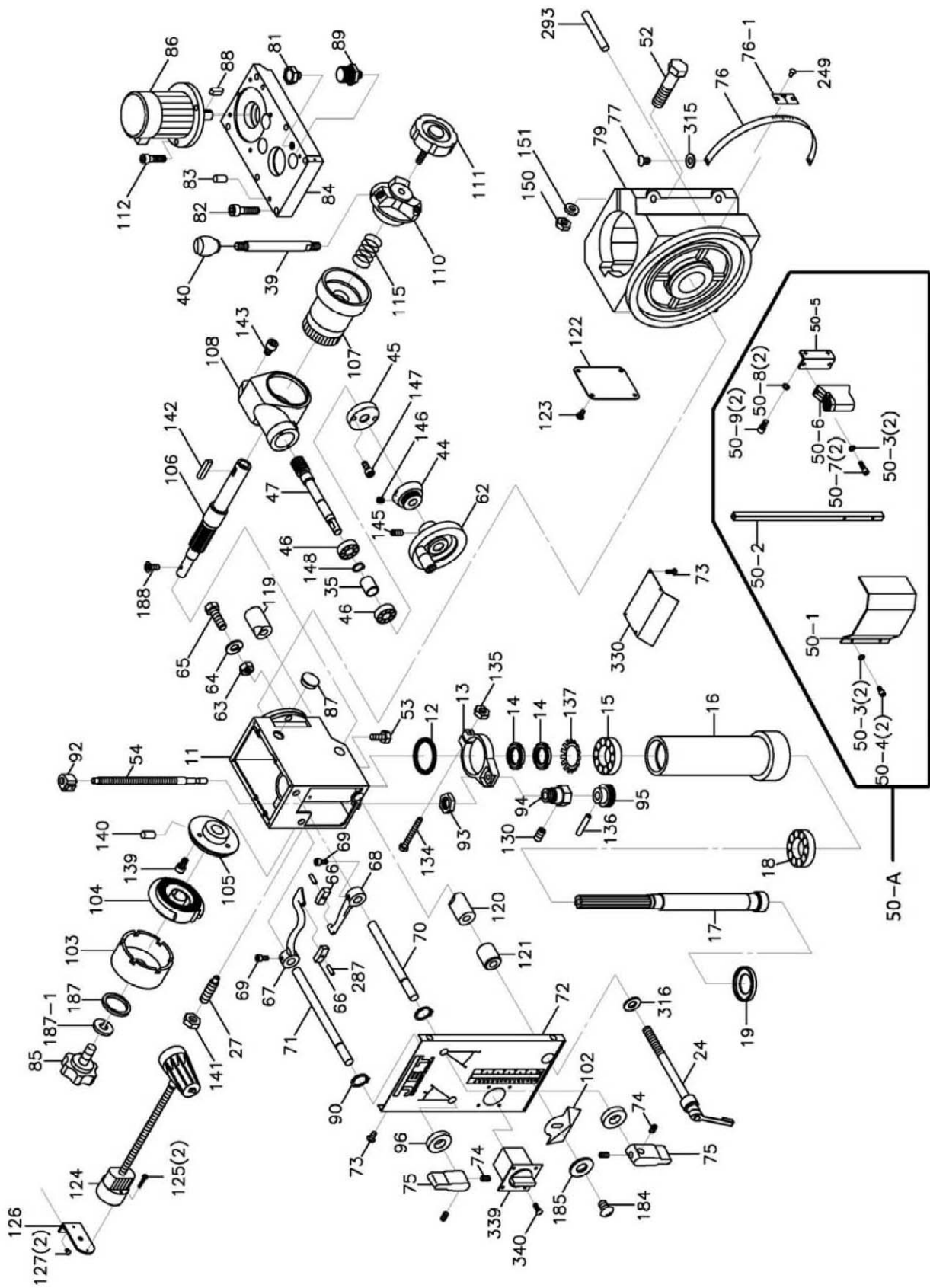

Parts List – GHD-20/20T Head Assembly

Index No.	Part No.	Description	Size	Qty
11	2401011G	Head Casting		1
12	6112	Rubber Gasket		1
13	6513	Feed Base		1
14	6114	Lock Nut		2
15	BB-30206	Taper Roller Bearing		1
16	6116	Rack Sleeve	MT3	1
17	6117	Spindle Shaft	MT3	1
18	BB-30207	Taper Roller Bearing		1
19	6119	Bearing Cap		1
24	2421003	Handle Rod		1
27	6127	Screw Key		1
35	6135	Bearing Spacer		1
39	6139	Handle Rod		3
	6139N	Handle Rod (serial #16031665 and higher)		3
40	290086	Knob		3
44	6144	Micro Adjusting Indicator		1
45	6145	Worm Cover		1
46	BB-6202Z	Ball Bearing		2
47	6147	Worm Shaft		1
50-A	GHD20-50-A	Chuck Guard Assembly (#50-1 thru 50-9)		1
50-1	JMD18-125-1	Chuck Guard		1
50-2	JMD18-125-2	Chuck Guard Supporting Rod		1
50-3	TS-2361051	Spring Washer	M5	4
50-4	TS-1502021	Hex Socket Head Screw	M5 x 10	2
50-5	GHD20-50-5	Chuck Guard Bracket		1
50-6	JMD18-125-5	Rotary Supporting Base		1
50-7	JMD18-125-6	Hex Socket Cap Screw	M5x15L	2
50-8	TS-1551041	Spring Washer	M6	2
50-9	6286490	Hex Socket Cap Screw	M6x15L	2
52	TS-0071141	Hex Cap Bolt	5/8" x 5-1/2"	2
53	GHD20-53	Oil Plug		1
54	GHD20-54	Threaded Rod		1
62	6142-2	Head Wheel		1
63	TS-0561071	Hex Nut	5/8"	3
64	TS-0680081	Washer		2
65	TS-0071041	Hex Screw	5/8" x 2-1/4"	3
66	2401066	Gear Lever Bracket		2
67	2401067	Gear Lever (Left)		1
68	2401068	Gear Lever (Right)		1
69	GHD20-69	Screw	1/4" x 1/2"	2
70	2401070	Lever Shaft (Right)		1
71	2401071	Lever Shaft (Left)		1
72	2401072	Name Plate (for GHD-20 only)		1
	GHD20T-72	Name Plate (for GHD20T only not - shown)		1
73	GHD20-73	Screw	3/16" x 3/8"	8
74	TS-0267021	Set Screw	1/4" x 1/4"	8
75	2401075	Speed Lever		2
76	GHD20-76	Scale		1
76-1	2401076-1	Pointer		1
77	GHD20-77	Screw		2
79	2412001G	Block		1
81	GHD20-81	Oil Plug		1
82	TS-0209061	Hex Socket Cap Screw	3/8" x 3/4"	6
83	GHD20-83	Miter Pin		2
84	2401084G	Cover		1
85	6185	Lock Handle		1
86	GHD20-86	Motor	2HP 3PH 230V	1
87	GHD20-87	Oil Sight Glass		1
88	GHD20-88	Key	6 x 6 x 30mm	1
89	GHD20-89	Brass Fitting		1

Index No.	Part No.	Description	Size	Qty
90	GHD20-90	C-Ring		2
92	6192	Block		1
93	6193	Nut		1
94	6194	Support Base		1
95	6195	Knob Assembly		1
96	GHD20-96	Oil Seal		2
101	61101	Bracket		1
102	61102	Limit Plate		1
103	61103	Spring Cover		1
104	61104	Spring		1
105	61105	Spring Base		1
106	61106	Pinion Shaft		1
107	61107	Worm Gear		1
108	61108G	Feed Cover		1
110	61110	Spring Base		1
111	6138	Lock Bolt w/ Knob		1
112	TS-0209051	Hex Socket Cap Screw	3/8" x 1"	3
115	61115	Spring		1
119	6126-1	Collar (thread)		1
120	6125-1	Collar		1
121	6125-2	Collar		1
122	61112G	Cover		1
123	GHD20-123	Screw		4
124	GHD20-124	Lamp Assembly		1
124-1	GHD20-124-1	Lamp Assembly (Independent power for GHD-20)		1
125	TS-2284352	Pan Head Screw	M4x35L	2
126	GHD20-126	Lamp Base		1
127	TS-1503031	Hex Socket Cap Screw	M6x12L	2
130	TS-1501021	Hex Socket Cap Screw	M4 x 8	1
134	TS-005091	Hex Cap Bolt	1/4" x 2"	1
135	TS-0561011	Hex Nut	1/4"	1
136	6195	Spring Pin		1
137	GHD20-137	Star Washer		1
139	GHD20-139	Screw	3/16" x 3/4"	3
140	GHD20-140	Spring Pin		1
141	TS-0561031	Hex Nut	3/8"	1
142	GHD20-142	Key	7 x 7 x 20	1
143	TS-0208021	Hex Socket Cap Screw	5/16" x 1/2"	2
145	TS-0270021	Set Screw	5/16" x 5/16"	1
146	TS-0267021	Set Screw	1/4" x 1/4"	1
147	GHD20-147	Hex Socket Cap Screw	3/16" x 7/16"	2
148	GHD20-148	C-Ring		1
150	TS-0561071	Hex Nut	5/8"	2
151	TS-0680081	Washer	5/8"	2
184	GHD20-184	Screw	5/32" x 1/4"	1
185	GHD20-185	Washer	1/4"	1
187	TS-0680021	Washer	1/4"	1
187-1	TS-0720071	Lock Washer	1/4"	1
188	GHD20-188	Screw	3/16" x 3/8"	1
249	GHD20-249	Rivet		2
287	GHD20-287	Spring Pin		2
330	2401085	Dust Plate		1
339	GHD20-339	Switch		1
340	GHD20-340	Screw		2
341	GHD20-341	Motor Cord		1
342	GHD20-342	Power Cord		1

Gear Assembly GHD-20PF, 20PFT

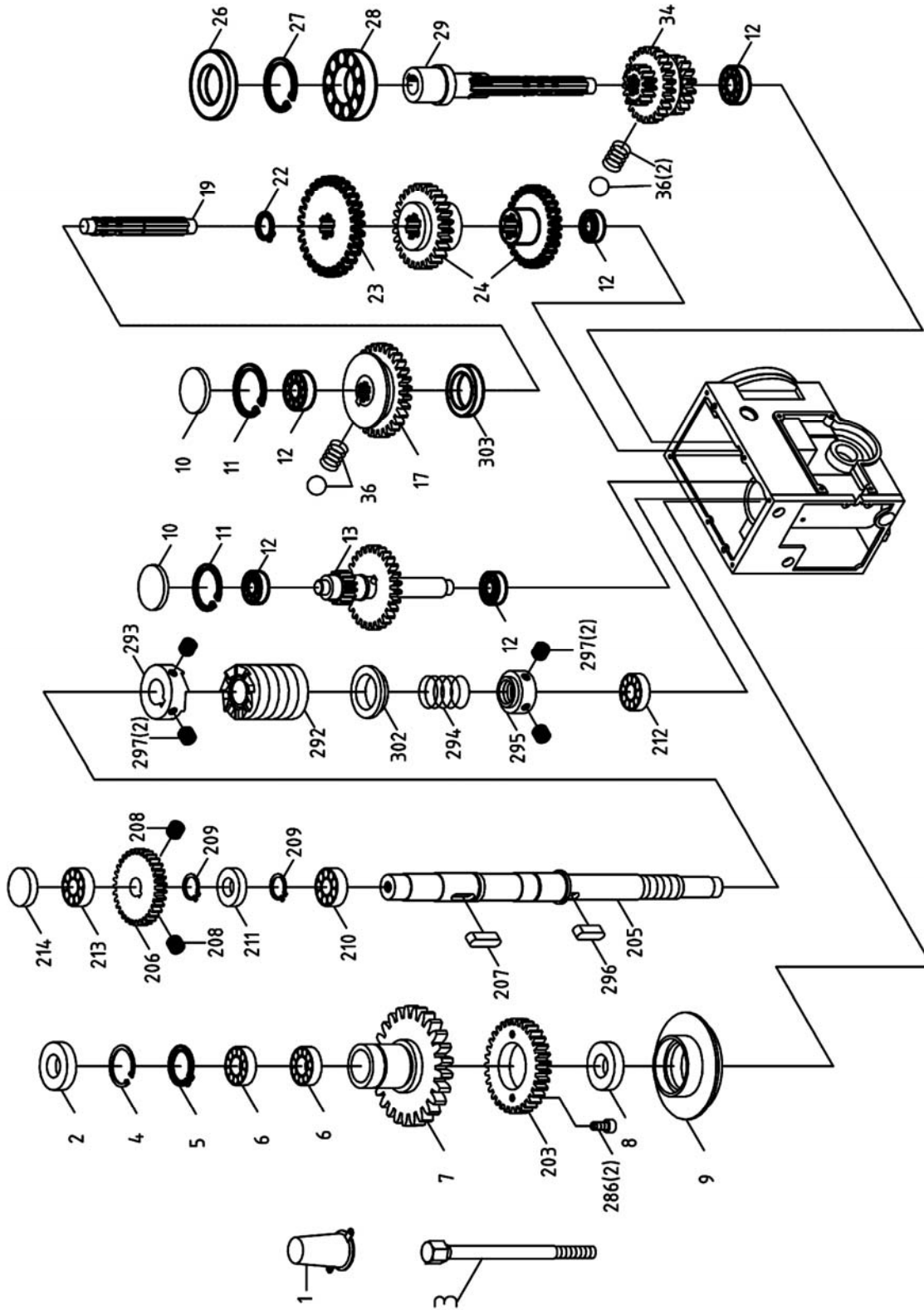

Parts List – Gear Assembly GHD-20PF, 20PFT

Index No.	Part No.	Description	Size	Qty
1	2401001-2	Main Shaft Cover		1
2	GHD20-28	Oil Seal		1
3	6101-2	Chuck Arbor Bolt	MT-3	1
4	GHD20-4	Retainer Ring	R68	1
5	GHD20PF-5	Retainer Ring	S40	1
6	BB6008ZZ	Ball Bearing		2
7	2401006	Idle Gear	53T	1
8	GHD20-7	Oil Seal		1
9	2401008	Oil Seal Ring		1
10	GHD20-9	Dust Cover		2
11	GHD20-10	C-Ring		2
12	BB-6002ZZ	Ball Bearing		5
13	2401020	Idle Gear		1
17	2401020A	Gear Shaft Assembly (s/n 7110881 and higher)	15/41T	1
	2401029	Idle Gear	35T	1
	2401029N	Idle Gear (s/n 7110881 and higher)	35T	1
19	2401031	Pinion Shaft		1
	SM2401031BS	Pinion Shaft w/Gear Assembly (s/n 7110881 and higher)		1
		(includes #17,#22,#23,#24,#36 and #303)		
22	GHD20-33	C-Ring	S18	1
23	2401055	Idle Gear	42T	1
	2401055N	Idle Gear (s/n 7110881 and higher)	42T	1
24	2401037	Idle Gear (2piece)	44/28T	1
	2401037N	Idle Gear (2piece) (s/n 7110881 and higher)	44/28T	1
26	GHD20-50	Oil Seal		1
27	GHD20-42	C-Ring	R62	1
28	BB-6007ZZ	Ball Bearing		1
29	2401043	Pinion Shaft		1
	SM2401043BS	Pinion Shaft W/Gear Assembly (s/n 7110881 and higher)		1
		(includes #26,#29,#34,#36)		
34	2401049	Idle Gear	15/31/43T	1
	2401049N	Idle Gear (s/n 7110881 and higher)	15/31/43T	1
36	GHD20-30	Steel Ball W/ Spring	5/16"	3
203	2450003	Idle Gear	15T	1
207	GHD20PF-207	Key	5x5x16	1
208	GHD20PF-208	Set Screw	M6x6	2
209	GHD20PF-209	C-Ring	S17	2
210	BB-6003ZZ	Ball Bearing		1
211	GHD20PF-211	Oil Seal		1
212	BB-6001ZZ	Ball Bearing		1
213	BB-6202ZZ	Ball Bearing		1
214	GHD20-214	Oil Seal Cover		1
286	GHD20-286	Hex Socket Cap Screw	M5x12	2
292	2450052	Worm Shaft		1
293	2450053	Clutch Block		1
294	2450054	Spring		1
295	2450055	Adjustable Bolt		1
296	GHD20PF-296	Key	5x5x10	1
297	GHD20PF-297	Set Screw	M5x5	4
302	2450057	Washer		1
303	2401192	Bushing		1

Gear Assembly GHD-20/20T

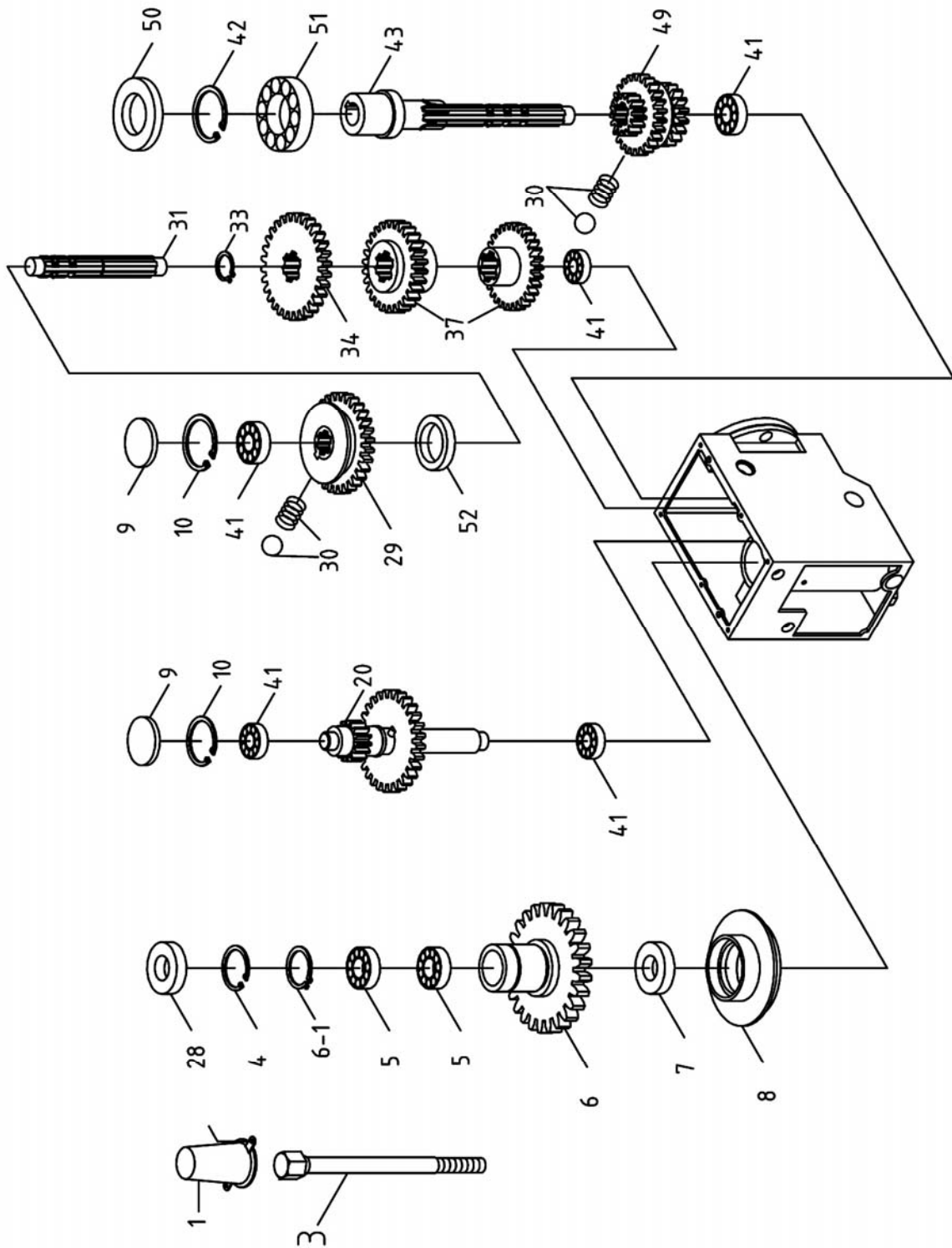

Parts List – Gear Assembly GHD-20/20T

Index No.	Part No.	Description	Size	Qty
1	2401001-2	Main Shaft Cover		1
2	6101-2	Chuck Arbor Bolt	MT-3	1
4	GHD20-4	Retainer Ring	R68	1
5	BB6008ZZ	Ball Bearing		2
6	2401006	Idle Gear	53T	1
6-1	GHD20-6-1	C-Ring		1
7	GHD20-7	Oil Seal		1
8	2401008	Oil Seal Ring		1
9	GHD20-9	Dust Cover		2
10	GHD20-10	C-Ring		2
20	2401020	Idle Gear		1
	2401020A	Gear Shaft Assembly (s/n 7110881 and higher)	15/41T	1
28	GHD20-28	Oil Seal		1
29	2401029	Idle Gear	35T	1
	2401029N	Idle Gear (s/n 7110881 and higher)	35T	1
30	GHD20-30	Steel Ball w/ Spring	5/16"	3
31	2401031	Pinion Shaft		1
	T2401031BS	Pinion Shaft w/Gear Assembly (s/n 7110881 and higher) (includes #29,#30,#31,#33,#34,#37 and #52)		1
33	GHD20-33	C-Ring	S18	1
34	2401055	Idle Gear	42T	1
	2401055N	Idle Gear (s/n 7110881 and higher)	42T	1
37	2401037	Idle Gear(2piece)	44/28T	1
	2401037N	Idle Gear (2piece) (s/n 7110881 and higher)	44/28T	1
41	BB-6002ZZ	Ball Bearing		5
42	GHD20-42	C-Ring	R62	1
43	2401043	Pinion Shaft		1
	T2401043BS	Pinion Shaft W/Gears Assembly (s/n 7110881 and higher) (includes #30, #43, #49,#50)		1
49	2401049	Idle Gear	15/31/43T	1
	2401049N	Idle Gear (s/n 7110881 and higher)	15/31/43T	1
50	GHD20-50	Oil Seal		1
51	BB-6007ZZ	Ball Bearing		1
52	2401192	Bushing		1

Base, Table and Column Assembly (all models)

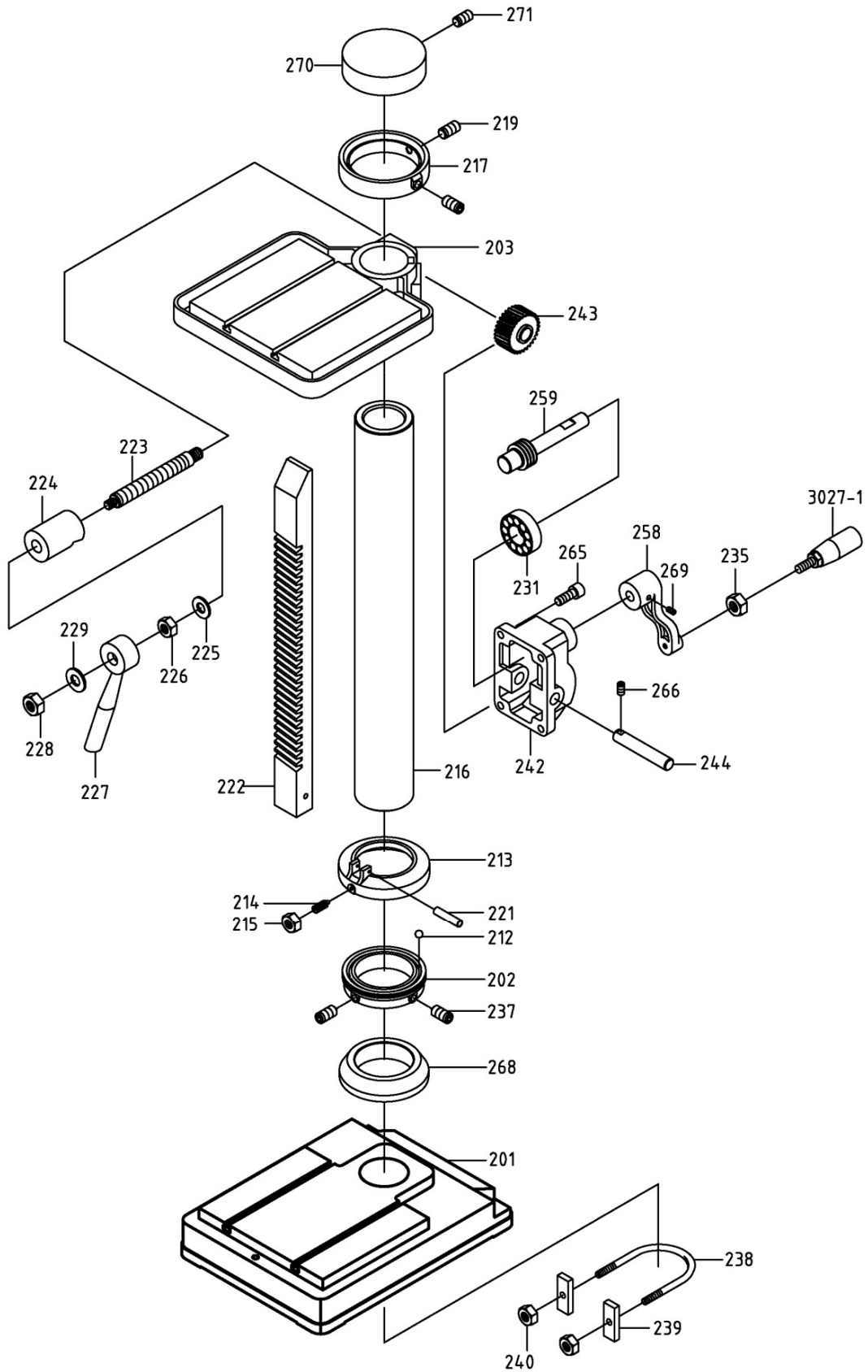

Parts List – Base, Table and Column Assembly (all models)

Index No.	Part No.	Description	Size	Qty
201	62201	Base		1
202	62202	Bearing Cover (lower)		1
203	62203-1	Table		1
212	SB-3/8	Steel Ball	3/8"	40
213	62213	Bearing Cover (upper)		1
214	62214	Screw		2
215	TS-0561021	Hex Nut	5/16"	2
216	62216	Column Base		1
217	62217G	Lock Ring		1
219	TS-0273031	Socket Set Screw	1/2" x 5/8"L	1
221	GHD20-221	Pin		1
222	62222	Rack		1
223	62223	Lock Bolt		1
224	62224-1	Lock Block		1
225	TS-0680081	Washer	5/8"	1
226	TS-0561031	Nut	5/8"	1
227	62227	Lock Handle		1
228	TS-0561031	Nut	3/8"	1
229	TS-0680041	Washer	3/8"	1
231	BB-51103	Thrust Bearing		1
235	TS-0561031	Nut	3/8"	1
237	TS-0267041	Set Screw	1/4" x 3/8"	2
238	62238	U-Bolt		1
239	62239	Block		1
240	TS-0561051	Nut	1/2"	2
242	62242G	Bracket		1
243	62243	Worm Gear		1
244	62244	Shaft		1
258	6158	Handle		1
259	62259	Worm Shaft		1
265	TS-0208061	Hex Socket Cap Screw	5/16" x 1"	4
266	TS-0267041	Set Screw	1/4" x 3/8"	1
268	62268	Bracket		1
269	TS-0270021	Set Screw	5/16" x 5/16"	1
270	6611	Column Cap		1
271	GHD20-271	Set Screw		1
3027-1	3027-1	Lever		1

Control Box Assembly (all models)

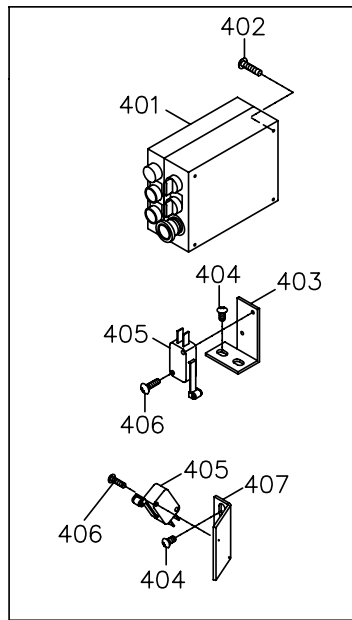
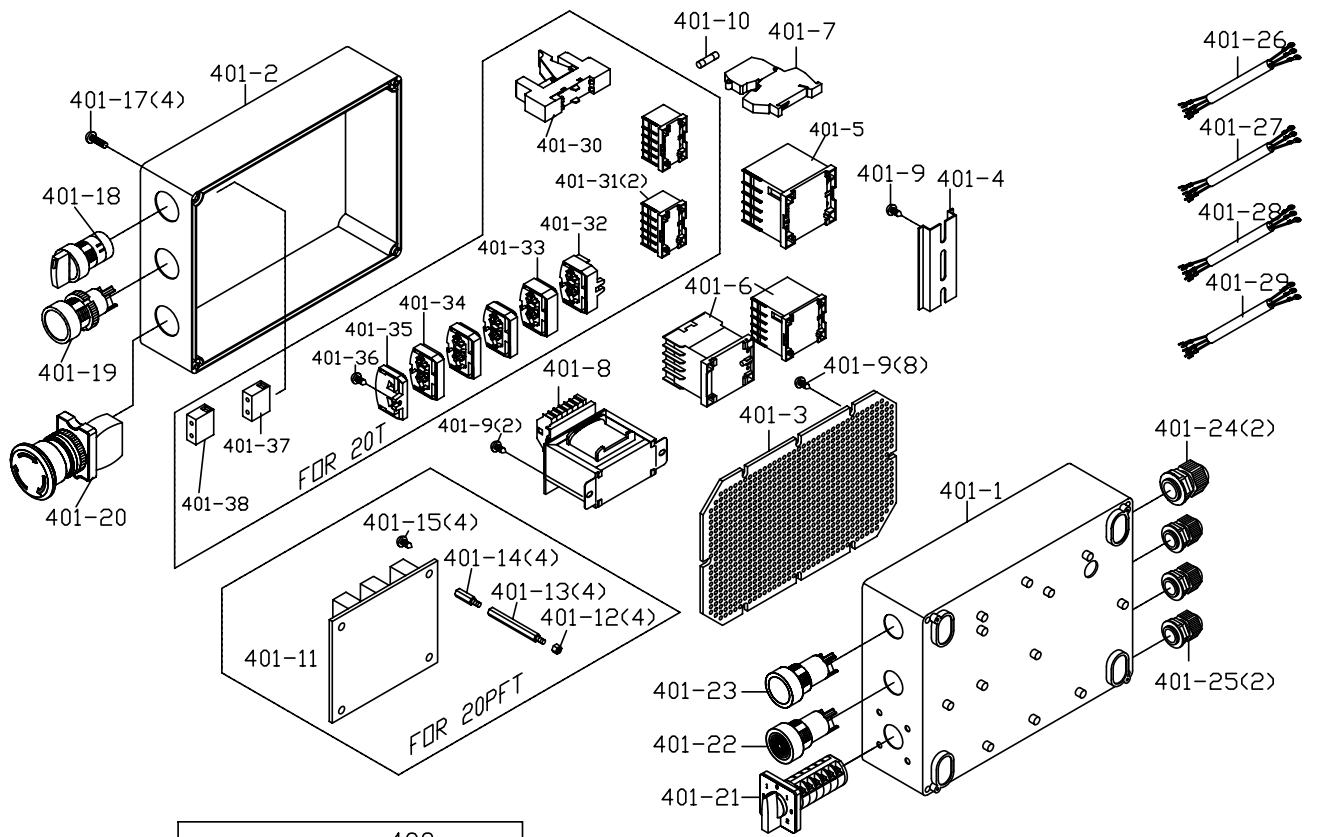

GHD-20T/20PFT only

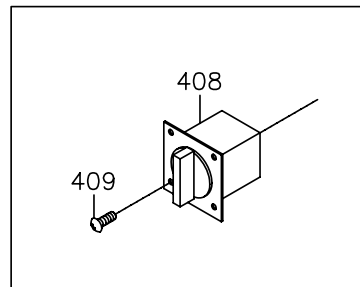

GHD-20/20PF only

Parts List – Control Box Assembly

Index No.	Part No.	Description	Size	Qty
401	GHD20PFT-401	Control Box		1
	GHD20PFT-CB	Control Box Complete (GHD-20PFT only)		1
	GHD20T-CB	Control Box Complete (#08050908 and higher)		1
401-1	GHD20PFT-401-1	Box Base		1
401-2	GHD20PFT-401-2	Box Cover		1
401-3	GHD20PFT-401-3	Support Plane		1
401-4	GHD20PFT-401-4	Bracket		1
401-5	ET-1123	Magnetic Contactor	LS GMC (D)-6M	2
401-6	ET-2034	Overload		1
401-7	GHD20PFT-401-7	Fuse Bracket		1
401-8	ET-1311	Transformer	20VA, 0.7Kg	1
401-9	GHD20PFT-401-9	Machine Screw	M4x10	12
401-10	ET-1820	Fuse	2A	1
401-11	ET-2504	Support Plate (GHD-20PFT only)		1
401-12	GHD20PFT-401-12	Hex Nut (GHD-20PFT only)	1/8"	4
401-13	GHD20PFT-401-13	Support Rod (GHD-20PFT only)	60mm	4
401-14	GHD20PFT-401-14	Support Rod (GHD-20PFT only)	15mm	4
401-15	GHD20PFT-401-15	Pan Head Screw (GHD-20PFT only)	1/8"x1/4	4
401-17	GHD20PFT-401-17	Pan Head Screw	M4x5	4
401-18	ET-1223	Select Switch	NHD NSS-S	1
401-19	ET-1221	Reverse Switch	NHD NPB-F	1
401-20	ET-1215	Emergency Switch	KEDU HY57B	1
401-21	GN20	High-Low Cam Switch	15A, 600VAC	1
401-22	ET-1414	Power Light	NHD NLD-22	1
401-23	ET-1217	Start Switch	NHD NPB-F	1
401-24	GHD20PFT-401-24	Clamp Plug	PG13.5	2
401-25	GHD20PFT-401-25	Clamp Plug	PG11	2
401-26	GHD20-341	Motor Plug	2.0mm ² x7C	1
401-27	GHD20PFT-401-27	Upper Limit Cord	0.75mm ² x2C	1
401-28	GHD20PFT-401-28	Lower Limit Cord	0.75mm ² x2C	1
401-29	GHD20-342	Power Cord	14AWGx4C	1
401-30	ET-1127	Relay	AC-24V	1
401-31	ET-1229	Auxiliary Contacts	LS, AU-2M	2
401-32	ET-1552	Ground Terminal		1
401-33	ET-1538	Two 2P Terminal		1
401-34	ET-1512	One 1P Terminal		3
401-35	ET-1516	Side Panel		1
401-36	S804	Pan Head Machine Screw	3/16x5/8	2
401-37	ET-1214	Contact Block	CB-10, A contact	2
401-38	ET-1215	Contacts Black	CB-10, B contact	2
402	GHD20PFT-402	Round Head Screw	3/16"x3/8"	4
403	GHD20PFT-403-1	Limit Bracket (top) (GHD-20PFT only)		4
	GHD20T-403-2	Limit Bracket (top) (GHD-20T only)		4
404	GHD20PFT-404	Round Head Screw	3/16"x5/8"	4
405	ET-1610	Limit Block		2
406	GHD20PFT-406	Round Head Screw	M3x15	4
407	GHD20PFT-407-1	Limit Support (GHD-20PFT only)		1
	GHD20T-407-2	Limit Support (GHD-20T only)		4
408	GHD20-339	High-Low Cam Switch		1
409	GHD20-340	Round Head Screw	M4x20	4

Electrical Panel Components (GHD-20PFT)

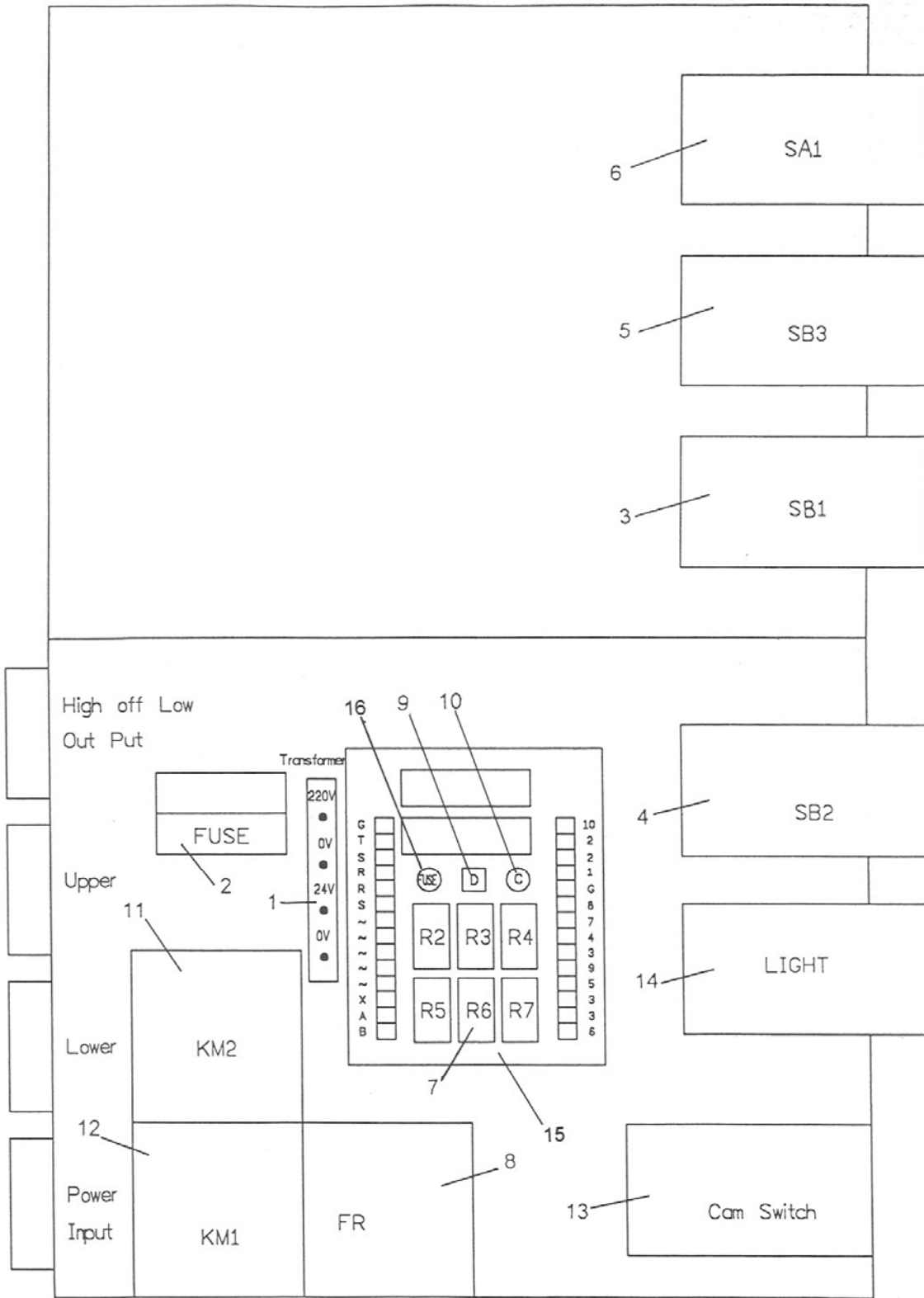

Parts List – Electrical Panel Components (GHD-20PFT)

Index No.	Part No.	Description	Size	Qty
1	ET-1311	Transformer	230V/24V	1
2	ET-1814	Fuse	2A	1
3	ET-1215	Emergency Stop Switch		1
4	ET-1217	Start Switch		1
5	ET-1221	Reverse Switch		1
6	ET-1223	Selecting Switch		1
7	RSA-24A	Control Relay (include R2, R3, R4, R5, R6, R7)		6
8	ET-2034	Overload Protector		1
9	DI-106	Bridge		1
10	33UF-25V	Capacitor		1
11	ET-1123	Magnetic Contactor (Forward)		1
12	ET-1123	Magnetic Contactor (Reverse)		1
13	GN-20	Cam Switch		1
14	ET-1414	Power Light		1
15	ET-2502A	Circuit Board Completely		1
16	ET-1814A	Fuse	1A	1

Electrical Schematic (GHD-20/20PF only)

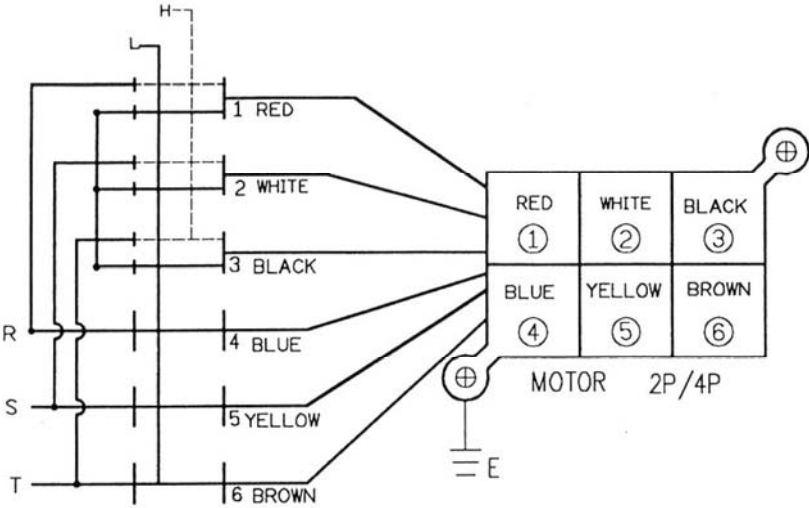

Electrical Schematic (GHD-20PFT)

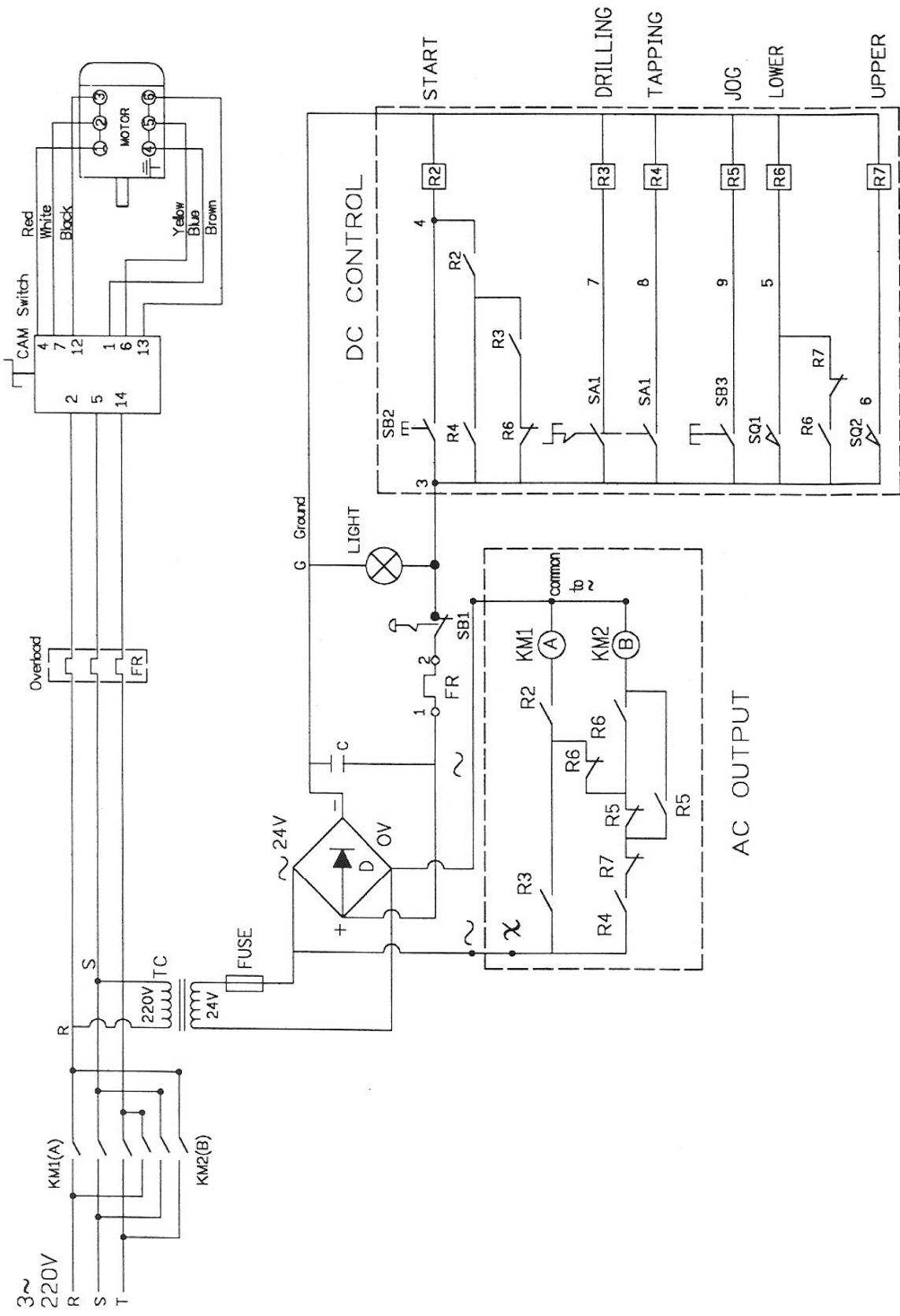

Electrical Schematic (GHD-20T)

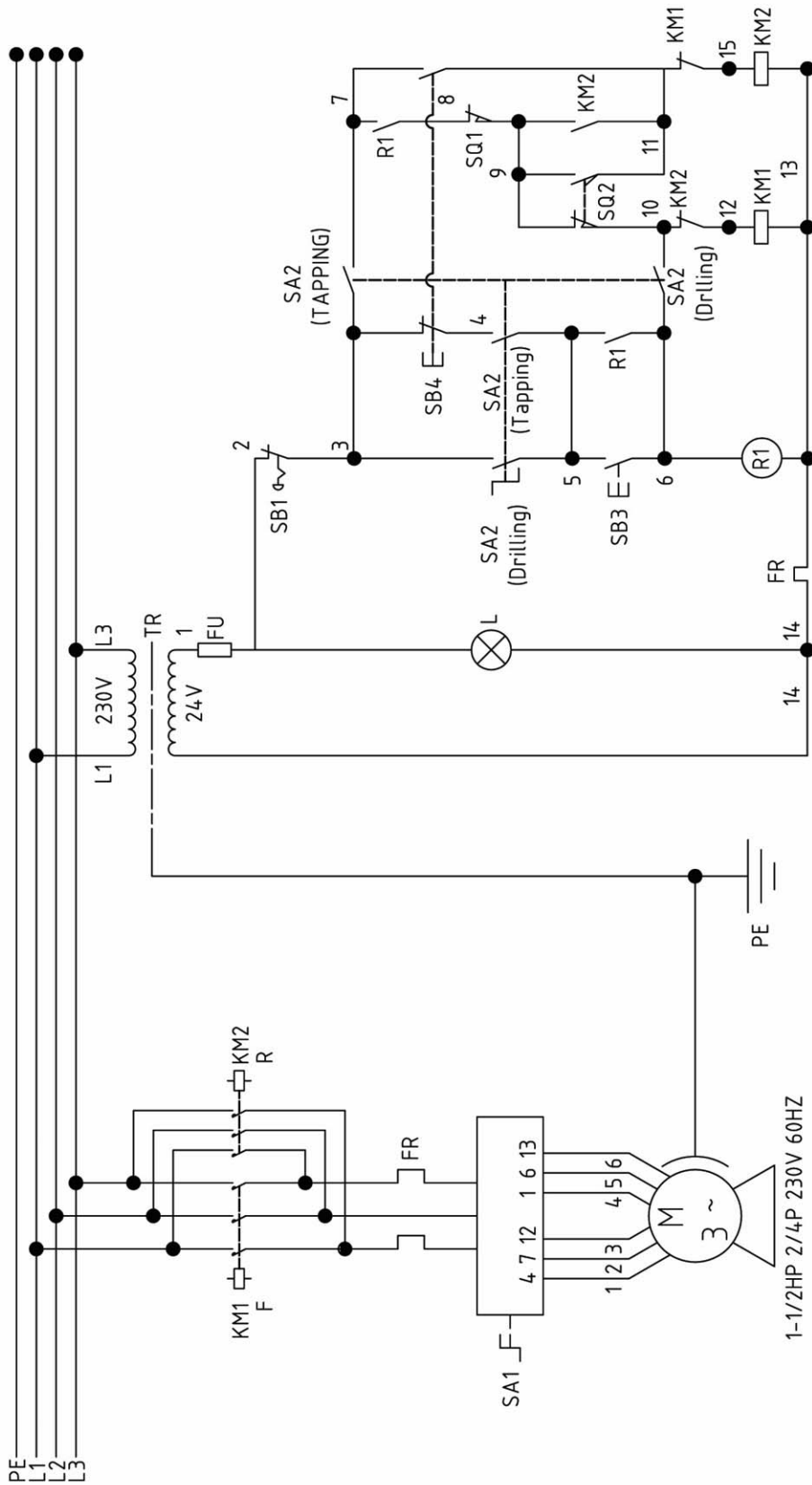

TR:Transformer
KM1:Contactor(Forward)
KM2:Contactor(Reverse)
FR:Overload
M:Motor

FU:Fuse
SB1:Emergency Stop Switch
SB3:Start Switch
SB4:Reverse Switch
SA2>Select Switch (Drilling/Tapping)

R1:Relay
SQ1:Upper Limit Switch
SQ2:Lower Limit Switch
L:Light
SA1:Lower & Hight Speed Control

This page intentionally left blank.

This page intentionally left blank.

This page intentionally left blank.



427 New Sanford Road
LaVergne, Tennessee 37086
Phone: 800-274-6848
www.jettools.com