

# Operation and Maintenance Instructions Geared Head Bench Lathe

Model GHB-1236

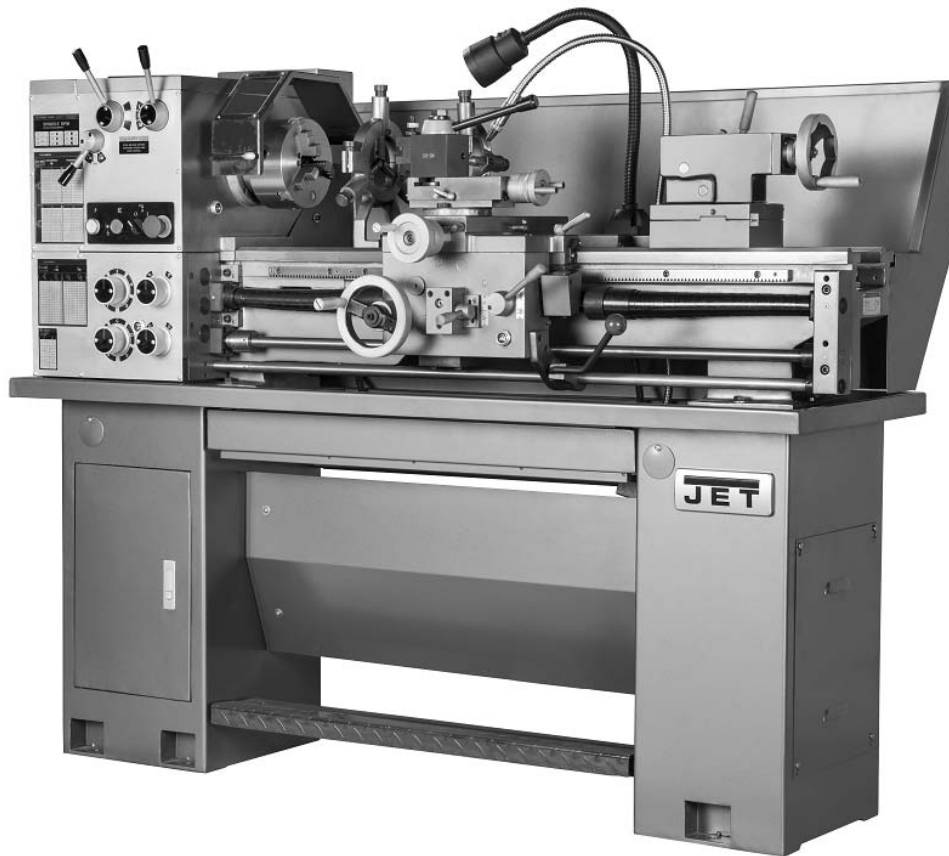

**JET**  
427 New Sanford Road  
LaVergne, Tennessee 37086  
Ph.: 800-274-6848  
[www.jettools.com](http://www.jettools.com)

**Part No. M-321236**  
Edition 1 04/2017  
Copyright © 2017 JET



## 1.0 IMPORTANT SAFETY INSTRUCTIONS

**Read and understand the entire owner's manual before attempting set-up or operation of this lathe.**

1. This machine is designed and intended for use by properly trained and experienced personnel only. If you are not familiar with the proper and safe use of lathes, do not use this machine until proper training and knowledge have been obtained.
2. Keep guards in place. Safety guards must be kept in place and in working order.
3. Remove adjusting keys and wrenches. Before turning on machine, check to see that any adjusting wrenches are removed from the tool.
4. Reduce the risk of unintentional starting. Make sure switch is in the OFF position before plugging in the tool.
5. Do not force tools. Always use a tool at the rate for which it was designed.
6. Use the right tool. Do not force a tool or attachment to do a job for which it was not designed.
7. Maintain tools with care. Keep tools sharp and clean for best and safest performance. Follow instructions for lubrication and changing accessories.
8. Always disconnect the tool from the power source before adjusting or servicing.
9. Check for damaged parts. Check for alignment of moving parts, breakage of parts, mounting, and any other condition that may affect the tool's operation. A guard or any part that is damaged should be repaired or replaced.
10. Turn power off. Never leave a tool unattended. Do not leave a tool until it comes to a complete stop.
11. Keep work area clean. Cluttered areas and benches invite accidents.
12. Do not use in a dangerous environment. Do not use power tools in damp or wet locations, or expose them to rain. Keep work area well lighted.
13. Keep children and visitors away. All visitors should be kept a safe distance from the work area.
14. Make the workshop child proof. Use padlocks, master switches, and remove starter keys.
15. Wear proper apparel. Loose clothing, gloves, neckties, rings, bracelets, or other jewelry may get caught in moving parts. Non-slip footwear is recommended. Wear protective hair covering to contain long hair. Do not wear any type of glove.
16. Always use safety glasses. Every day glasses only have impact resistant lenses; they are not safety glasses.
17. Do not overreach. Keep proper footing and balance at all times.
18. Do not place hands near the chuck while the machine is operating.
19. Do not perform any set-up work while machine is operating.
20. Read and understand all warnings posted on the machine.
21. This manual is intended to familiarize you with the technical aspects of this lathe. It is not, nor was it intended to be, a training manual.
22. CALIFORNIA PROPOSITION 65 WARNING: This product contains chemicals known to the State of California to cause cancer, or birth defects or other reproductive harm.
23. This product, when used for welding, cutting, or working with metal, produces fumes, gases, or dusts which contain chemicals known to the State of California to cause birth defects and, in some cases, cancer. (California Health and Safety Code Section 25249.5 et seq.)
24. Do not attempt to adjust or remove tools during operation.
25. Never stop a rotating chuck or workpiece with your hands.
26. Choose a low spindle speed when working unbalanced workpieces, and for threading and tapping operations.
27. Do not exceed the maximum speed of the workholding device.
28. Do not exceed the clamping capacity of the chuck.
29. Workpieces longer than 3 times the chucking diameter must be supported by the tailstock or a steady rest.
30. Avoid small chuck diameters with large turning diameters.
31. Avoid short chucking lengths and small chucking contact.
32. Turn off the machine and disconnect from power before cleaning. Use a brush to remove shavings or debris — do not use your hands.

33. Do not stand on the machine. Serious injury could occur if the machine tips over.
34. Never leave the machine running unattended. Turn the power off and do not leave the machine until moving parts come to a complete stop.

35. Remove loose items and unnecessary work pieces from the area before starting the machine.
36. Do not operate the lathe in flammable or explosive environments. Do not use in a damp environment or expose to rain.

**Familiarize yourself with the following safety notices used in this manual:**

**CAUTION** This means that if precautions are not heeded, it may result in minor injury and/or possible machine damage.

**WARNING** This means that if precautions are not heeded, it may result in serious, or possibly even fatal, injury.

## 2.0 About this manual

This manual is provided by JET, covering the safe operation and maintenance procedures for a JET Model GHB-1236 Lathe. This manual contains instructions on installation, safety precautions, general operating procedures, and maintenance instructions. Your machine has been designed and constructed to provide consistent, long-term operation if used in accordance with the instructions as set forth in this document.

This manual is not intended to be a training guide for lathe operations, or tool and workpiece selection. Consult a machinery handbook or shop supervisor for information on proper speed and feed rates for specific materials, or type of cutter suitable for a particular operation. Whatever accepted methods or materials are used, always make personal safety a priority.

If there are questions or comments, please contact your local supplier or JET. JET can also be reached at our web site: [www.jettools.com](http://www.jettools.com).

Retain this manual for future reference. If the machine transfers ownership, the manual should accompany it.

**WARNING** **Read and understand the entire contents of this manual before attempting assembly or operation! Failure to comply may cause serious injury!**

Register your product using the mail-in card provided, or register online: <http://www.jettools.com/us/en/service-and-support/warranty/registration/>

## 3.0 Table of contents

Section	Page
1.0 IMPORTANT SAFETY INSTRUCTIONS .....	2
2.0 About this manual .....	3
3.0 Table of contents .....	4
4.0 Specifications .....	6
4.1 Dimensions for provided stand .....	7
5.0 Setup and assembly .....	8
5.1 Shipping contents .....	8
5.2 Uncrating and cleanup .....	9
5.3 Chuck preparation (three jaw) .....	9
5.4 Chuck guard installation .....	10
6.0 Lubrication .....	10
7.0 Electrical connections .....	11
7.1 GROUNDING INSTRUCTIONS .....	11
7.2 Extension cords .....	12
8.0 General description .....	12
8.1 Lathe bed .....	12
8.2 Carriage .....	12
8.3 Headstock .....	12
8.4 Quick change tool post .....	12
8.5 Apron .....	13
8.6 Tailstock .....	13
8.7 Leadscrew and feed rod .....	13
8.8 Gear box .....	13
8.9 Steady rest .....	13
8.10 Follow rest .....	13
9.0 Controls .....	13
10.0 Operation .....	15
10.1 Break-in procedure .....	15
10.2 Feed and thread selection .....	15
10.3 Change gear replacement .....	15
10.4 Automatic feed operation and feed changes .....	15
10.5 Powered carriage travel .....	16
10.6 Thread cutting .....	16
11.0 Adjustments .....	16
11.1 Saddle adjustment .....	16
11.2 Cross slide adjustment .....	16
11.3 Compound slide adjustment .....	16
11.4 Tailstock adjustment .....	16
11.5 Half nut gib adjustment .....	17
11.6 Headstock alignment .....	17
11.7 Removing gap bridge .....	17
11.8 Installing gap bridge .....	17
12.0 Thread and feed chart .....	18
13.0 Replacement parts .....	19
13.1.1 Bed Assembly – Exploded View .....	19
13.1.2 Bed Assembly – Parts List .....	19
13.2.1 Headstock Assembly – Exploded View .....	20
13.2.2 Headstock Assembly – Parts List .....	22
13.3.1 Gearbox Assembly – Exploded View .....	24
13.3.2 Gearbox Assembly – Parts List .....	26
13.4.1 Apron Assembly – Exploded View .....	28
13.4.2 Apron Assembly – Parts List .....	29
13.5.1 Cross Slide Assembly – Exploded View .....	31
13.5.2 Cross Slide Assembly – Parts List .....	32
13.6.1 Compound Rest Assembly – Exploded View .....	33
13.6.2 Compound Rest Assembly – Parts List .....	34
13.7.1 Tailstock Assembly – Exploded View .....	36
13.7.2 Tailstock Assembly – Parts List .....	37

13.8.1	Change Gears – Exploded View .....	38
13.8.2	Change Gears – Parts List .....	38
13.9.1	Feed Rod Assembly – Exploded View .....	39
13.9.2	Feed Rod Assembly – Parts List .....	40
13.10.2	Motor and Change Gear Enclosure – Exploded View .....	41
13.10.2	Motor and Change Gear Enclosure – Parts List .....	42
13.11.1	Stand/Brake/Coolant Pump – Exploded View .....	43
13.11.2	Stand/Brake/Coolant Pump – Parts List .....	45
13.12.1	Electrical Box Assembly – Exploded View .....	46
13.12.2	Electrical Box Assembly – Parts List .....	47
13.13.1	Steady Rest and Follow Rest – Parts List .....	48
13.13.2	Steady Rest and Follow Rest – Parts List .....	49
13.14.1	Chuck and Leadscrew Guards – Exploded View .....	50
13.14.2	Chuck and Leadscrew Guards – Parts List .....	50
13.15.1	Accessories – Exploded View .....	51
13.15.2	Accessories – Parts List .....	52
14.0	Wiring Diagram for GHB-1236 .....	53
15.0	Warranty and service .....	54

## 4.0 Specifications

Table 1

Model number	<b>GHB-1236</b>
Stock number	321236
<b>Motor and Electricals</b>	
Motor type	TEFC induction
Horsepower	2 HP (1.5 kW)
Phase	single
Voltage	230V only
Cycle	60 Hz
Listed FLA (full load amps)	8.5 A
Start capacitor	150 $\mu$ F 250V
Run capacitor	20 $\mu$ F 450V
Motor speed	1720 RPM
Power cord	16AWG, 3 x 1.31 mm <sup>2</sup>
Power plug installed	n/a
Recommended circuit size <sup>1</sup>	15 A
Sound emission without load <sup>2</sup>	88 dB
<b>Capacities</b>	
Swing over bed	13 in. (330 mm)
Swing over cross slide	7-1/2 in. (190.5 mm)
Distance between centers	33 in. (838 mm)
Swing through gap	18 in. (457 mm)
Length of gap	8-3/4 in. (222.25 mm)
Steady rest capacity	5/16 – 2-15/16 in. (8 – 74.6 mm)
Follow rest capacity	2-3/16 in. (55.6 mm)
<b>Headstock</b>	
Hole through spindle	1-9/16 in. (39.7 mm)
Spindle nose	D1-4
Taper in spindle nose	MT5
Spindle taper adaptor	MT3
Spindle bearing type	Taper roller bearing
Number of spindle speeds	9
Range of spindle speeds	75-1400 RPM
Leadscrew	7/8 in. x 8 TPI
Feed rod diameter	3/4 in. (19 mm)
<b>Gearbox</b>	
Number of longitudinal and cross feed rates	48/36
Range of longitudinal feeds	0.0019 – 0.0472 in./rev
Range of cross feeds	0.0014 – 0.0116 in./rev
Number of inch threads	36
Range of inch threads	4 – 60 TPI
Number of metric threads	32
Range of metric threads	0.4 – 7 mm
<b>Compound and carriage</b>	
Tool post type	Quick change
Maximum tool size	5/8 x 5/8 in.
Maximum compound slide travel	3 in. (76.2 mm)
Maximum cross slide travel	5-1/2 in. (140 mm)
Maximum carriage travel	27-3/8 in. (695.3 mm)

<b>Tailstock</b>	
Tailstock spindle travel	3-1/2 in. (89 mm)
Diameter of tailstock spindle	1-1/4 in. (31.8 mm)
Taper in tailstock spindle	MT3
<b>Main materials</b>	
Headstock	Cast iron
Bed	Cast iron
Apron/Saddle	Cast iron
Tailstock	Cast iron
Splash guard	Steel
Stand	Steel
<b>Dimensions</b>	
Bed width	7-1/8 in. (181 mm)
Overall dimensions, L x W x H	66-3/16 x 29-1/2 x 57-1/2 in. (1681 x 749.3 x 1460.5 mm)
Shipping dimensions, L x W x H	66-1/2 x 29-9/16 x 57-1/8 in. (1690 x 750 x 1451 mm)
<b>Weights</b>	
Net weight, approx.	1210 lb. (548.8 kg)
Shipping weight, approx.	1430 lb. (648.6 kg)

<sup>1</sup> subject to local and national electrical codes.

<sup>2</sup> The specified values are emission levels and are not necessarily to be seen as safe operating levels. As workplace conditions vary, this information is intended to allow the user to make a better estimation of the hazards and risks involved only.

L = length, W = width, H = height, TPI = threads per inch

n/a = not applicable

The specifications in this manual were current at time of publication, but because of our policy of continuous improvement, JET reserves the right to change specifications at any time and without prior notice, without incurring obligations.

#### 4.1 Dimensions for provided stand

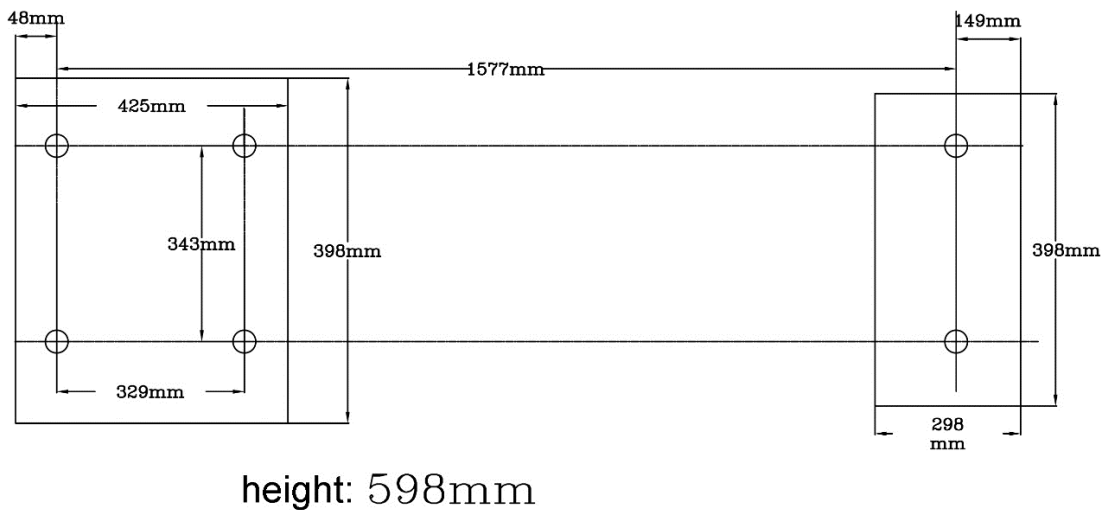

Figure 4-1: stand dimensions

## 5.0 Setup and assembly

### 5.1 Shipping contents

See Figure 5-1.

- 1 Lathe
- 1 Steady Rest (mounted on lathe)
- 1 Follow Rest (mounted on lathe)
- 1 6" Three Jaw Chuck (mounted on lathe)
- 1 8" Four Jaw Chuck (strapped to container)
- 1 10" Face Plate (strapped to container)
- 1 Tool Box (strapped to container)
- 1 Chip Tray
- 1 Splash Guard

#### **Tool Box contents:**

- 3 Open End Wrenches (10/12, 14/17, 17/19mm)
- 1 Oil Gun
- 1 Hex Key Set (2, 3, 4, 5, 6mm)
- 1 22T Gear
- 1 26T Gear
- 1 38T Gear
- 1 44T Gear
- 1 52T Gear
- 2 MT-3 Dead Centers
- 1 MT-3 Live Center
- 1 MT-3 to MT-5 Center Sleeve
- 1 Cross Point Screwdriver
- 1 Flat Head Screwdriver
- 1 Quick Change Tool Holders (250-202, 250-204, 250, 207, 250-210)
- 1 Key for 3-Jaw Chuck
- 1 Key for 4-Jaw Chuck
- 1 Key for Cam Locks
- 1 Set of Reverse Jaws for 3-Jaw Chuck
- 1 Handle for Cross Slide Handwheel
- 1 Handle for Apron Handwheel
- 2 V-Belts (A-813)
- 6 Leveling Pads (with M14x50 Bolts & Washers)
- 1 Operation and Maintenance Instructions
- 1 Packing List
- 1 Test Record
- 1 Product Registration Card



Figure 5-1

## 5.2 Uncrating and cleanup

**⚠WARNING** Machine is heavy. Use an appropriate lifting device and use extreme caution when moving the machine to its final location. Failure to comply may cause serious injury.

1. Finish removing wooden crate from around lathe.
2. Unbolt lathe from shipping crate bottom.
3. Choose a location for the lathe that is dry, has good lighting, and has enough room to be able to service the lathe on all four sides.
4. Move carriage and tailstock to the tailstock end of the bed.
5. Place two steel rods or pipes of sufficient strength into four holes (A, Figure 5-2) of lathe stand. Sling the lathe with properly rated straps. **Do not lift by spindle.** With adequate lifting equipment, slowly raise lathe off shipping crate bottom. Make sure lathe is balanced before moving to sturdy bench or optional stand.



Figure 5-2

6. To avoid twisting the bed, the lathe's location must be absolutely flat and level. Bolt lathe to stand (if used). If using a bench, through-bolt for best performance.
7. Clean all rust protected surfaces using a mild commercial solvent, kerosene or diesel fuel. Do not use paint thinner, gasoline, or lacquer thinner, as these will damage painted surfaces. Cover all cleaned surfaces with a light film of Mobil DTE® Oil Heavy Medium or equivalent.
8. Remove end gear cover. Clean all components of end gear assembly and coat all gears with a heavy, non-slinging grease.
9. Using a machinist's precision level on the bedways, check to make sure lathe is level side to side and front to back. If necessary,

loosen mounting bolts, shim, and retighten mounting bolts. The lathe must be level to be accurate.

## 5.3 Chuck preparation (three jaw)

**⚠WARNING** Read and understand all directions for chuck preparation. Failure to comply may cause serious injury and/or damage to the lathe.

**Note:** Before removing chuck from spindle, place a way board across bedways under the chuck.

1. Support the chuck while turning three camlocks 1/4 turn counter-clockwise with the chuck key enclosed in the toolbox. Figure 5-3 shows the cam in the secure position. Line up the two marks (A, Figure 5-3) for removal.

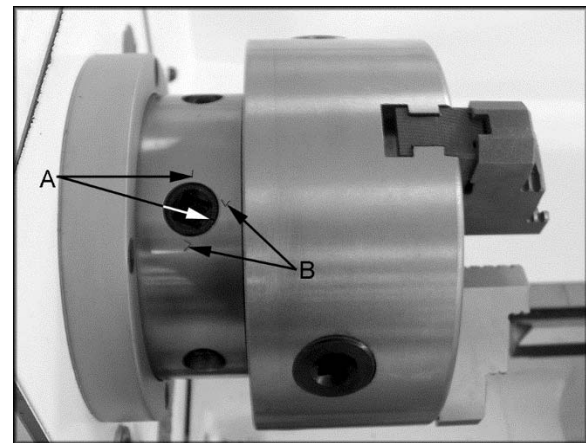

Figure 5-3

2. Carefully remove chuck from spindle and place on an adequate work surface.
3. Inspect the camlock studs. Make sure they have not become cracked or broken during transit. Clean all parts thoroughly with solvent. Also clean spindle and camlocks.
4. Cover all chuck jaws and scroll inside the chuck with Mobilith® AW2. Cover spindle, cam locks, and chuck body with a light film of Mobil DTE® Oil Heavy Medium.
5. Lift chuck up to spindle nose and press onto spindle. Tighten in place by turning cam locks 1/4 turn clockwise. The index mark (A, Figure 5-3) on the camlock should be between the two indicator arrows (B, Figure 5-3). If the index mark is not between the two arrows, remove chuck and adjust the camlock studs by either turning out one full turn (if cams will not engage) or turning in one full turn (if cams turn beyond indicator marks).
6. Install chuck and tighten in place.

**ATTENTION:** Only when the incised line on chuck lines up with that on the spindle, can the chuck be mounted.

## 5.4 Chuck guard installation

Install chuck guard to headstock, if it is not already mounted. (See parts breakdown if clarification is needed for assembly.)

## 6.0 Lubrication

**CAUTION** Lathe must be serviced at all lubrication points and all reservoirs filled to operating level before lathe is placed into service. Failure to comply may cause serious damage to lathe.

1. **Headstock** – Oil must be up to indicator mark in oil sight glass (A, Figure 6-1). Top off with Mobil DTE® Oil Heavy Medium. Fill by pulling plug located on top of headstock cover beneath rubber mat. Drain oil by removing drain plug (C, Figure 6-2) and refill after first month of operation. Clean out any metal shavings. Then, change oil in headstock annually.
2. **External Gears** – Coat all gears with a heavy, non-slinging grease, see Figure 6-2. Do **not** get grease on pulleys or belts.
3. **Gear Shaft** – Remove set screw (F, Figure 8-2) and oil with a couple drops of Mobil DTE® Oil Heavy Medium once weekly.
4. **Gearbox** – Oil must be up to indicator mark in oil sight glass (B, Figure 6-1). Top off with Mobil DTE® Oil Heavy Medium. Fill by removing plug (D, Figure 6-2). Drain oil by removing drain plug (E, Figure 6-2) and refill after first month of operation. Then, change oil in gearbox annually.
5. **Apron** – Oil must be up to indicator mark in oil sight glass (A, Figure 6-3). Top off with Mobil DTE® Oil Heavy Medium. Fill by removing oil plug (B, Figure 6-3). After the first three months of operation, drain oil completely (drain is on bottom of apron) and refill with Mobil DTE® Oil Heavy Medium, or equivalent to the indicator line. Then, change oil annually.
6. **Carriage** – Lubricate two ball oilers on top of carriage once daily with Mobil DTE® Oil Heavy Medium.

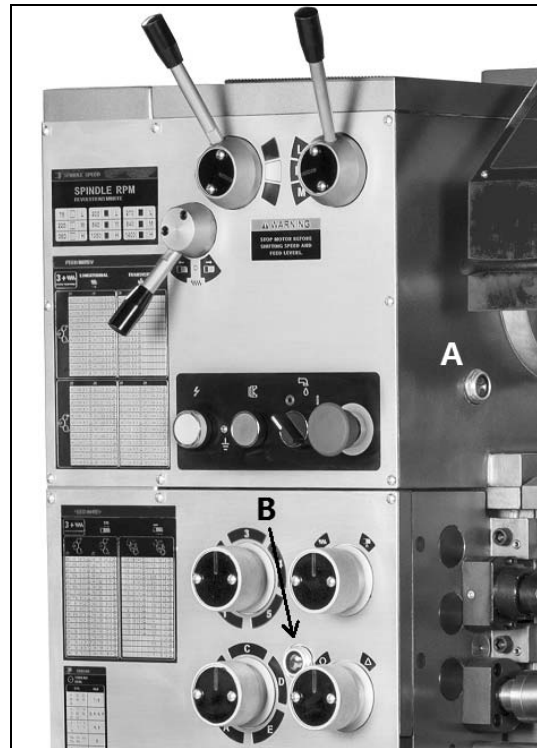

Figure 6-1

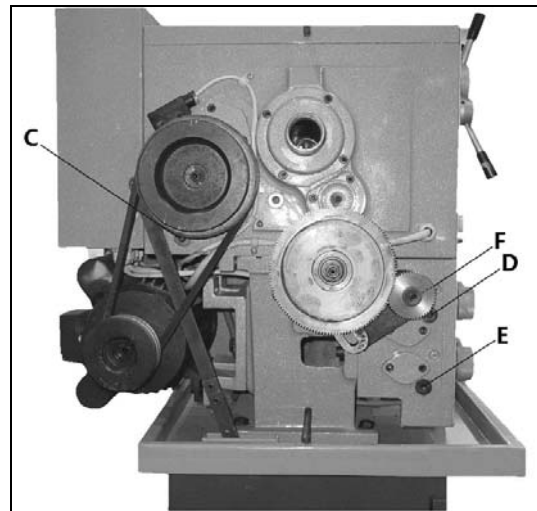

Figure 6-2

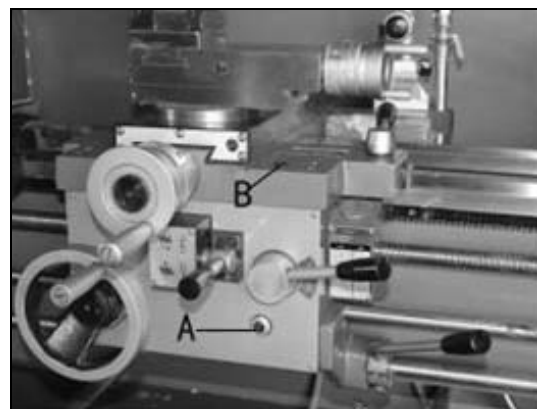

Figure 6-3

7. **Compound Rest** – Lubricate three ball oilers (F, Figure 6-4) once daily with Mobil DTE® Oil Heavy Medium.
8. **Cross Slide** – Lubricate four ball oilers (G, Figure 6-4) once daily with Mobil DTE® Oil Heavy Medium.
9. **Longitudinal Feed Handwheel** – Lubricate ball oiler (H, Figure 6-4) once daily with Mobil DTE® Oil Heavy Medium.

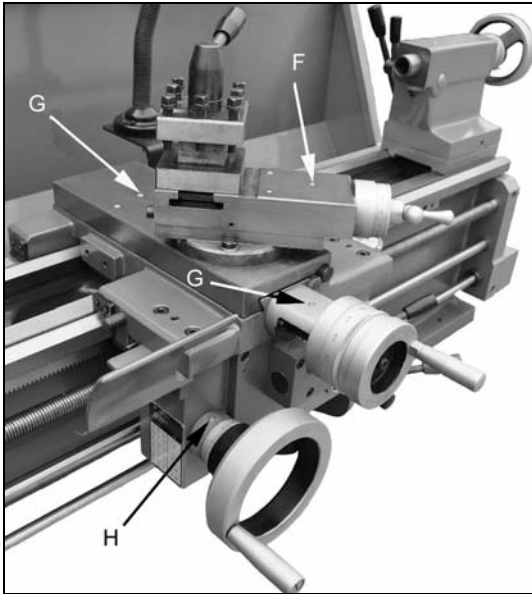

Figure 6-4

10. **Tailstock** – Lubricate ball oilers (I, Figure 6-5) once daily with Mobil DTE® Oil Heavy Medium.
11. **Leadscrew/Feed Rod** – Lubricate ball oilers once daily (J, Figure 6-5) with Mobil DTE® Oil Heavy Medium.

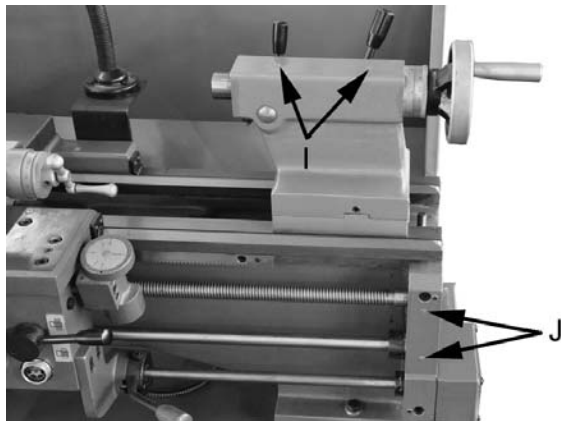

Figure 6-5

## 7.0 Electrical connections

**⚠ WARNING** All electrical connections must be done by a qualified electrician in compliance with all local codes and ordinances. Failure to comply may result in serious injury.

The GHB-1236 Lathe is rated at 230-volt power only. It is not provided with a power plug; you may either attach a proper 230V UL-listed plug, or “hardwire” the machine directly to a service panel (make sure a disconnect is available to the operator).

Before connecting to power source, be sure switch is in *off* position.

It is recommended that the lathe be connected to a dedicated 15 amp circuit with circuit breaker or fuse. **Local codes take precedence over recommendations.**

### 7.1 GROUNDING INSTRUCTIONS

This tool must be grounded. In the event of a malfunction or breakdown, grounding provides a path of least resistance for electric current to reduce the risk of electric shock. This tool is equipped with an electric cord having an equipment-grounding conductor. If a plug is used, the plug must be inserted into an appropriate outlet that is properly installed and grounded in accordance with all local codes and ordinances.

**⚠ WARNING** Improper connection of the equipment-grounding conductor can result in a risk of electric shock. Check with a qualified electrician or service person if you are in doubt as to whether the outlet is properly grounded. Do not modify the plug – if it will not fit the outlet, have a proper outlet installed by a qualified electrician.

The conductor with insulation having an outer surface that is green with or without yellow stripes is the equipment-grounding conductor. If repair or replacement of the electric cord or plug is necessary, do not connect the equipment-grounding conductor to a live terminal.

Use only 3-wire extension cords that have 3-prong grounding plugs and 3-pole receptacles that accept the tool's plug.

Repair or replace damaged or worn cord immediately.

#### If used with a plug:

Grounded, cord-connected tools intended for use on a supply circuit having a nominal rating between 150-250 V inclusive:

This tool is intended for use on a circuit that has an outlet that looks like the one illustrated in Figure 7-1. The tool is intended for use with a grounding plug that looks like the plug illustrated in Figure 7-1. Make sure the tool is connected to an outlet having the same configuration as the plug. No adapter is available or should be used with this tool. If the tool must be reconnected for use on a different type of electric circuit, the reconnection should be made by qualified service personnel; and after reconnection, the tool should comply with all local codes and ordinances.

**If hardwired:**

Permanently connected tools: This tool should be connected to a grounded metal permanent wiring system; or to a system having an equipment-grounding conductor.

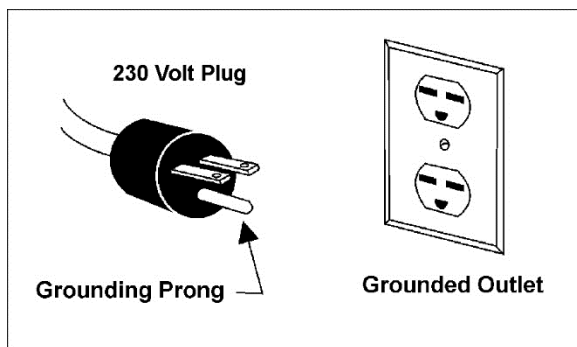

Figure 7-1

**7.2 Extension cords**

The use of extension cords is discouraged; try to position equipment within reach of the power source. If an extension cord becomes necessary, be sure it is heavy enough to carry the current your product will draw. An undersized cord will cause a drop in line voltage resulting in loss of power and overheating.

Table 1 shows recommended size to use depending on cord length and nameplate ampere rating. If in doubt, use the next heavier gauge. The smaller the gauge number, the heavier the cord.

Ampere Rating		Volts	Total length of cord in feet			
More Than	Not More Than		50	100	200	300
		240	AWG			
0	6		18	16	16	14
6	10		18	16	14	12
10	12		16	16	14	12
12	16		14	12	Not Recommended	

Table 2: Extension cord recommendations

**8.0 General description**

**8.1 Lathe bed**

The lathe bed (A, Figure 8-1) is made of high grade cast iron. By combining high cheeks with strong cross ribs, a bed with low vibration and high rigidity is realized. Two precision ground V-slideways, reinforced by heat hardening and grinding, are an accurate guide for the carriage and headstock. The main drive motor is mounted to the rear of the bed.

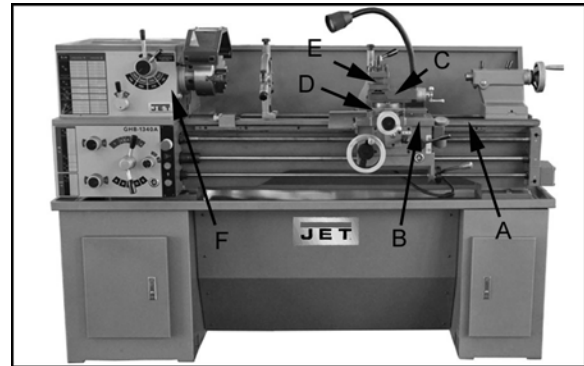

Figure 8-1

**8.2 Carriage**

The carriage (B, Fig. 10) is made from high quality cast iron. The sliding parts are smooth ground. The cross-slide is mounted on the carriage and moves on a dove-tailed slide which can be adjusted for play by means of gibs.

The compound slide (C, Figure 8-1), which is mounted on the cross slide (D, Figure 8-1), can be rotated through 360°. The compound slide and the cross slide travel in a dovetail slide and have adjustable gibs. A four-way tool post (E, Figure 8-1) is fitted on the compound slide.

**8.3 Headstock**

The headstock (F, Figure 8-1) is cast from high grade, low vibration cast iron. It is mounted to the bed by four bolts with two adjusting bolts for alignment. In the head, the spindle is mounted on two precision taper roller bearings. The hollow spindle has Morse Taper #5 with a 1-9/16" bore.

**8.4 Quick change tool post**

The quick change tool post (E, Figure 8-1) is mounted on the compound slide and allows tool holders to be mounted easily. Remember to use a minimum of two clamping screws when installing a cutting tool.

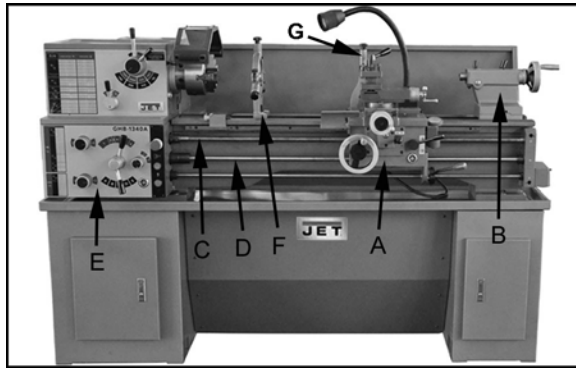

Figure 8-2

### 8.5 Apron

The apron (A, Figure 8-2) is mounted to the carriage. In the apron a half nut is fitted. The half nut gibs can be adjusted from the outside. The half nut is engaged by use of a lever. Quick travel of the apron is accomplished by means of a bed-mounted rack and pinion, operated by a handwheel on front of apron.

### 8.6 Tailstock

The tailstock (B, Figure 8-2) slides on a v-way and can be locked at any location by a clamping lever. The tailstock has a heavy-duty spindle with a Morse Taper #3.

### 8.7 Leadscrew and feed rod

The leadscrew (C Figure 8-2) and feed rod (D, Figure 8-2) are mounted on the front of machine bed. They are connected to the gearbox at the left for automatic feed and lead. They are supported by bushings on both ends.

### 8.8 Gear box

The gear box (E, Figure 8-2) is made from high quality cast iron and is mounted to left side of machine bed.

### 8.9 Steady rest

The steady rest (F, Figure 8-2) serves as a support for shafts on the free tailstock end. The steady rest is mounted on the bedway and secured from below with bolt, nut and locking plate.

### 8.10 Follow rest

The traveling follow rest (G, Figure 8-2) is mounted on the saddle and follows the movement of the turning tool. Only two fingers are required as the turning tool takes the place of the third. The follow rest is used for tuning operations on long, slender workpieces. It prevents flexing of the workpiece from the pressure of the cutting tool.

The sliding fingers are set similar to the steady rest, free of play, but not binding. The sliding fingers require continuous lubrication at the contact points with the workpiece to prevent premature wear.

## 9.0 Controls

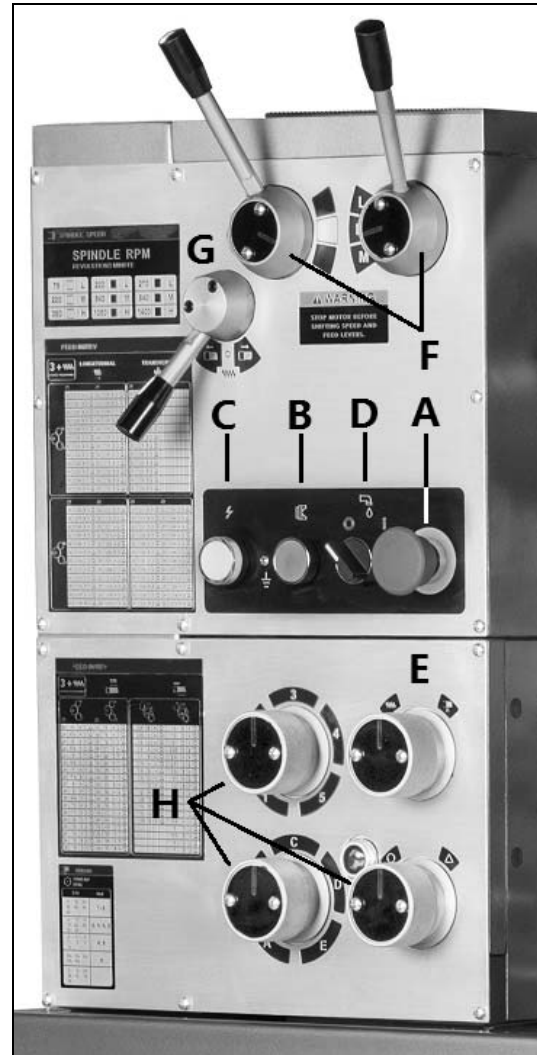

Figure 9-1

1. **Emergency Stop Switch (A, Figure 9-1)** – Press to stop all machine functions. **Caution: lathe will still have power.** Turn clockwise to re-set.
2. **Jog Switch (B, Figure 9-1)** – Press and release to advance spindle momentarily.
3. **Power Indicator Light (C, Figure 9-1)** – Illuminates whenever lathe has power.
4. **Coolant On-Off Switch (D, Figure 9-1)** – Turns coolant pump on and off.
5. **Feed Rod/Leadscrew Selector (E, Figure 9-1)** – Use knob to activate leadscrew and feed rod.

6. **Speed Selector Levers** (F, Figure 9-1) – Use to select spindle speeds in ranges.
7. **Feed Direction Selector** (G, Figure 9-1) – Selects carriage travel direction when chuck is rotating in forward direction (or counterclockwise as viewed from front of chuck).
8. **Feed Rate Selector** (H, Figure 9-1) – Use knobs to set desired feed, or lead rates.
9. **Longitudinal Traverse Handwheel** (A, Figure 9-2) – Rotate handwheel clockwise to move apron assembly toward tailstock (right). Rotate handwheel counterclockwise to move apron assembly toward headstock (left).
10. **Feed Selector** (B, Figure 9-2) – Push lever to the left and down to activate crossfeed function. Pull lever to the right and up to activate longitudinal function.
11. **Half Nut Engagement Lever** (thread cutting) (C, Figure 9-2) – Move lever down to engage. Move lever up to disengage.
12. **Cross Traverse Handwheel** (D, Figure 9-2) – Clockwise rotation moves cross slide toward rear of machine.
13. **Compound Slide Traverse Handwheel** (E, Figure 9-2) – Rotate clockwise to move or position.
14. **Tool Post Clamping Lever** (F, Figure 9-2) – Rotate counterclockwise to loosen and clockwise to tighten. Rotate tool post when lever is unlocked.
15. **Threading Dial** (G, Figure 9-2) – Engage by pushing into the leadscrew. Pull out to disengage. The dial indicator and chart will specify at which point a thread can be entered.
16. **Forward/Reverse Lever** (H, Figure 9-2) – Pull lever up for clockwise spindle rotation (reverse). Push lever down for counterclockwise spindle rotation (forward). Neutral position is a center detent and spindle remains idle.
17. **Compound Rest Lock** (I, Figure 9-3) – Turn hex nut clockwise to lock and counterclockwise to unlock.
18. **Compound Slide Lock** (J, Figure 9-4) – Turn set screw clockwise to tighten and counterclockwise to loosen.
19. **Cross Slide Lock** (K, Figure 9-4) – Turn set screw clockwise, and tighten to lock. Turn counterclockwise and loosen to unlock.

**CAUTION** Cross slide lock screw must be unlocked before engaging automatic feeds or damage to lathe may occur.

20. **Carriage Lock** (L, Figure 9-4) – Turn hex socket cap screw clockwise and tighten to

lock. Turn counterclockwise and loosen to unlock.

**CAUTION** Carriage lock screw must be unlocked before engaging automatic feeds or damage to lathe may occur.

21. **Tailstock Quill Clamping Lever** (M, Figure 9-4) – Lift up to lock spindle. Push down to unlock.
22. **Tailstock Clamping Lever** (N, Figure 9-4) – Lift up lever to lock. Push down lever to unlock.
23. **Tailstock Quill Traverse Hand wheel** (O, Figure 9-4) – Rotate clockwise to advance quill. Rotate counterclockwise to retract quill.
24. **Tailstock Off-Set Adjustment** – Three set screws located on tailstock base are used to off-set tailstock for cutting tapers. Loosen lock screw on tailstock end. Loosen one side set screw (P, Figure 9-4) while tightening the other until the amount of off-set is indicated on scale. Tighten lock screw.

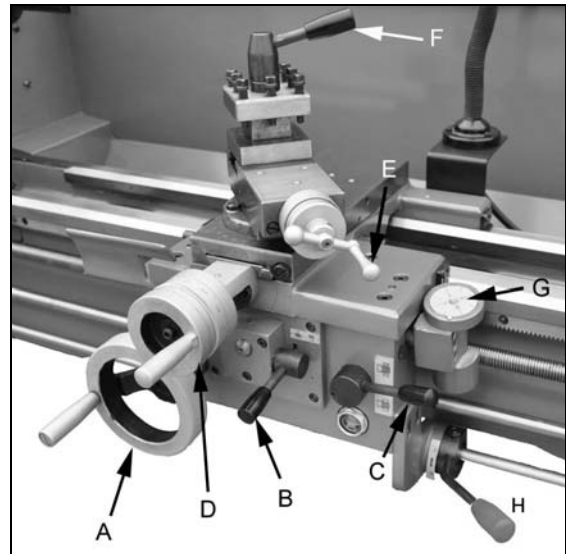

Figure 9-2

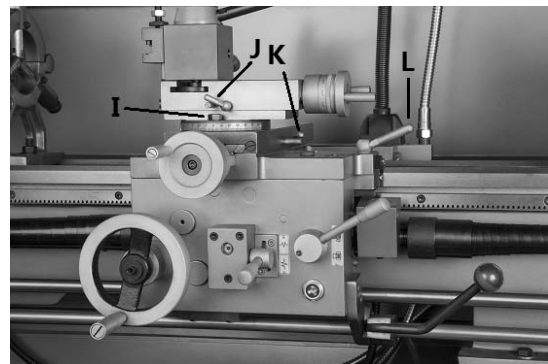

Figure 9-3

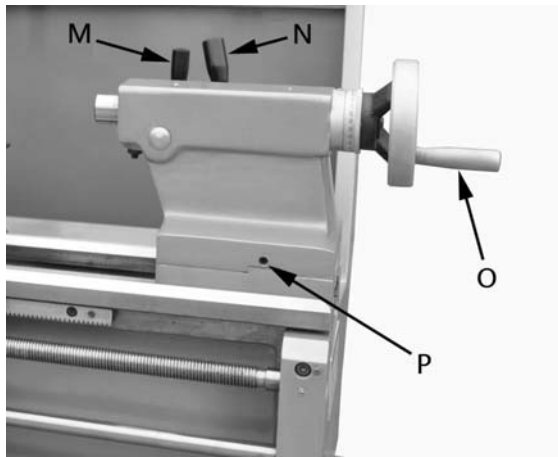

Figure 9-4

## 10.0 Operation

### 10.1 Break-in procedure

During manufacturing and testing, this lathe has been operated in the low RPM range for three hours.

To allow time for the gears and bearings to break-in and run smoothly, do not run the lathe above 755 RPM for the first six hours of operation and use.

### 10.2 Feed and thread selection

1. Reference the feed and thread table (A, Figure 10-1).
2. Move knobs and handle (B, Figure 10-1) to appropriate positions.

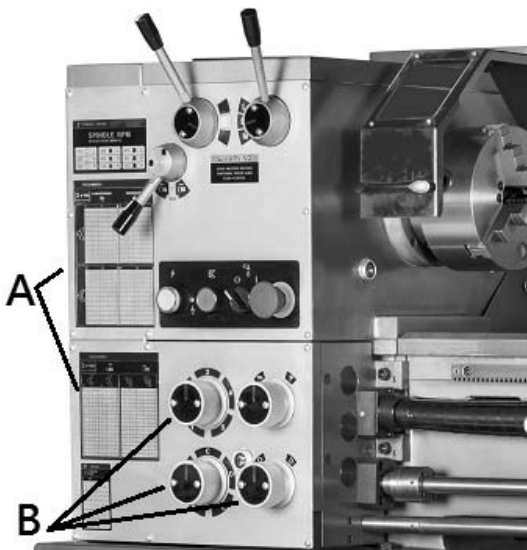

Figure 10-1

### 10.3 Change gear replacement

**Note:** The 24T, 127T, and 48T gears are installed in the end gear compartment when delivered from the factory. This combination will cover most inch

feeds and threads under normal circumstances. The additional gears found in the toolbox are used for some metric threads and feeds.

1. Disconnect machine from power source.
2. Open the cover on left end of headstock.
3. Loosen hex nuts (E/F, Figure 10-2). Move quadrant out of the way.
4. Change gears (G, Figure 10-2) to match feed and thread chart.
5. Thoroughly clean and install new gears.
6. Move quadrant so the large gear meshes with the smaller gears, and tighten to secure in place. Note: Make sure there is backlash of 0.002" – 0.003" between gears. Setting gears too tight will cause excessive noise and wear.
7. Close cover and connect machine to power source.

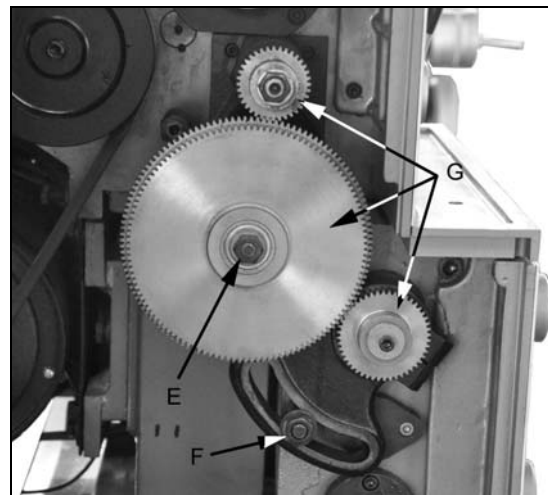

Figure 10-2

### 10.4 Automatic feed operation and feed changes

1. Move the forward/reverse selector (A, Figure 10-3) up or down depending on desired direction.

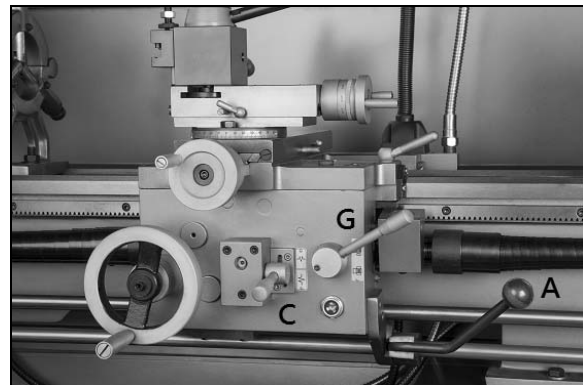

Figure 10-3

- Turn knob (B, Figure 10-4) counterclockwise so the arrow is pointing up to start the feed rod rotating.

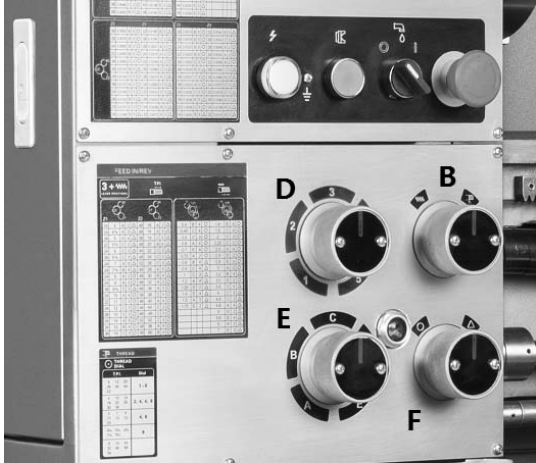

Figure 10-4

## 10.5 Powered carriage travel

Push lever (C, Figure 10-3) down to engage cross feed. Pull lever up to engage longitudinal feed.

## 10.6 Thread cutting

- Set feed rate selectors (D/E/F, Figure 10-4) in proper position for correct feed rate of the thread pitch to be cut.
- Turn knob (B, Figure 10-4) clockwise so the arrow is pointing up to start the thread cutting.
- Engage half nut lever (G, Figure 10-3).
- The half nut lever and the threading dial are used to thread in the conventional manner. The thread dial chart specifies at which point a thread can be entered using the threading dial.
- To cut metric threads, the half nuts must be left continually engaged once the start point has been selected and the half nut is initially engaged (thread dial cannot be used).

## 11.0 Adjustments

### 11.1 Saddle adjustment

- Loosen four hex nuts (A, Figure 11-1) found on the bottom rear of cross slide.
- Turn each of four set screws (B, Figure 11-1) equally with a hex wrench until a slight resistance is felt. Do not overtighten.
- Move carriage with handwheel and determine if drag is to your preference. Readjust setscrews as necessary to achieve desired drag.
- Hold socket set screw firmly with a hex wrench and tighten hex nut to lock in place.

- Move the carriage again and adjust if necessary. **Note:** Over-adjustment will cause excessive, premature wear of gibs.

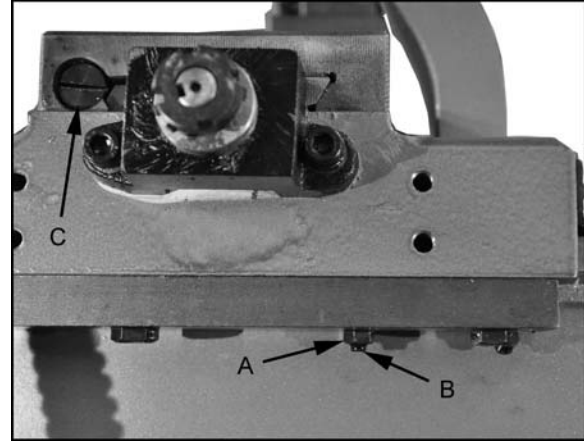

Figure 11-1

### 11.2 Cross slide adjustment

If the cross slide is too loose, follow procedure below to tighten:

- Loosen the rear gib screw (C, Fig. 20) approximately one turn.
- Tighten front gib screw a quarter turn. Turn the cross slide handwheel to see if the cross slide is still loose. If it is still loose, tighten the front screw a bit more and try again.
- When cross slide is properly adjusted, snug rear gib screw. Do not overtighten; this will cause premature wear on the gib and mating parts.

### 11.3 Compound slide adjustment

Follow same procedure as for cross slide adjustment, to adjust the compound rest.

### 11.4 Tailstock adjustment

If the handle will not lock the tailstock securely, use the following procedure:

- Lower handle to unlocked position.
- Slide tailstock to an area that will allow you to reach under the tailstock.
- Tighten tailstock clamping nut 1/4 turn, and re-test for proper locking. Repeat as necessary.

## 11.5 Half nut gib adjustment

1. Remove thread dial assembly by unscrewing the screw (D, Figure 11-2).
2. Loosen three hex nuts (E, Figure 11-2) found on side of apron, and turn three set screws (F, Figure 11-2) equally with a hex wrench.
3. Adjust properly for wear and play. Hold socket set screw firmly with a hex wrench and tighten hex nut to lock in place. **Note:** Over-adjustment will cause excessive, premature wear on gib and mating parts.

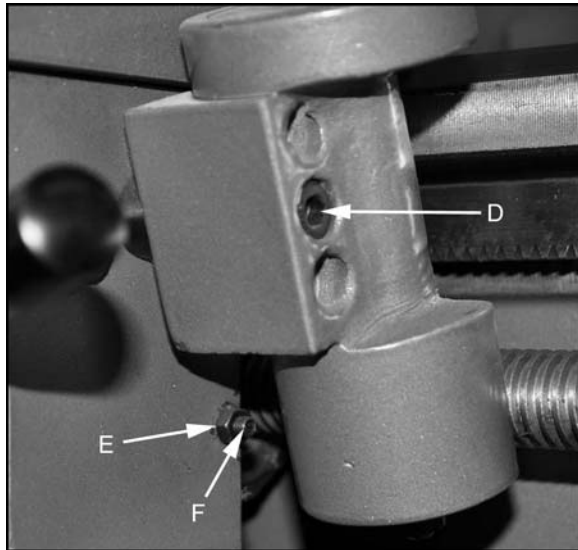

Figure 11-2

## 11.6 Headstock alignment

The headstock has been aligned at the factory and should not require adjustment. However, if adjustment is deemed necessary, follow procedure below to align headstock.

1. Using an engineer's precision level on the bedways, make sure lathe is level side-to-side and front-to-back. If lathe is not level, correct to a level condition before proceeding. Re-test alignment if any leveling adjustments were made.
2. From steel bar stock of approximately two inches in diameter, cut a piece approximately eight inches long.
3. Place two inches of bar stock into chuck and tighten chuck. Do not use tailstock or center to support the other end.
4. Set up and cut along five inches of bar stock.
5. Using a micrometer, measure bar stock next to the chuck and at the end. The measurement should be the same.
6. If the measurements are not the same and adjustment is required, loosen the four bolts that hold headstock to bed. Do not loosen completely; some drag should remain.

7. Loosen two hex nuts found on the two adjusting bolts located on backside of headstock just above motor mount bracket. Adjust the bolts for alignment and tighten hex nuts. Tighten headstock bolts and make another cut. Keep adjusting screws after each cut until the bar stock measurements are the same. Tighten all headstock bolts and jam nuts on adjusting screws.

## 11.7 Removing gap bridge

1. Using an open end wrench, tighten the two hex nuts (A, Figure 11-3). This will cause the taper pins (B, Figure 11-3) to release. Remove the taper pins.
2. Remove the four hex socket cap screws (C, Figure 11-3) with a hex key wrench.
3. Gap bridge can now be removed.

## 11.8 Installing gap bridge

1. Clean bottom and ends of gap bridge thoroughly.
2. Set gap bridge in place and align.
3. Remove nuts (A, Figure 11-3) from taper pins (B, Figure 11-3).
4. Slide taper pins in their respective holes and seat using a mallet. Install nuts on taper pins finger tight.
5. Install four socket head cap screws (C, Figure 11-3) and tighten securely.

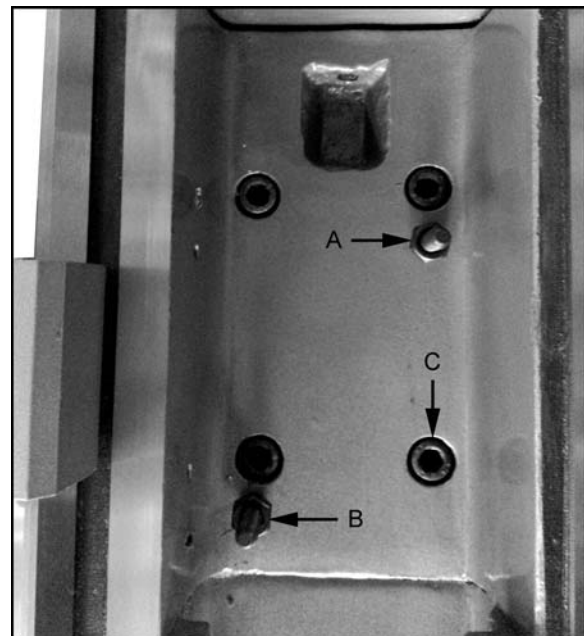

Figure 11-3

# 12.0 Thread and feed chart

## FEEDIN/REV

### LONGITUDINAL

Z1			Z1			Z1		
52	0,0019	B 5 ○	48	0,0042	B 5 △	48	0,0072	C 3 △
48	0,0021	B 5 ○	44	0,0046	B 5 △	44	0,0078	C 3 △
44	0,0023	B 5 ○	38	0,0046	C 3 ○	38	0,0080	E 2 ○
38	0,0026	B 5 ○	38	0,0052	B 5 △	38	0,0091	C 3 △
52	0,0033	C 3 ○	52	0,0059	E 2 ○	52	0,0118	E 2 △
48	0,0036	C 3 ○	48	0,0063	E 2 ○	48	0,0126	E 2 △
52	0,0038	B 5 △	52	0,0066	C 3 △	44	0,0138	E 2 △
44	0,0039	C 3 ○	44	0,0069	E 2 ○	38	0,0160	E 2 △

Z2			Z2			Z2		
38	0,0052	B 5 ○	24	0,0146	C 3 ○	22	0,0236	A 2 ○
26	0,0076	B 5 ○	26	0,0152	B 5 △	26	0,0268	C 3 △
24	0,0083	B 5 ○	22	0,0157	C 3 ○	38	0,0274	A 2 △
22	0,0090	B 5 ○	24	0,0166	B 5 △	24	0,0292	C 3 △
38	0,0092	C 3 ○	22	0,0180	B 5 △	22	0,0314	C 3 △
38	0,0104	B 5 △	38	0,0184	C 3 △	26	0,0402	A 2 △
26	0,0134	C 3 ○	26	0,0201	A 2 ○	24	0,0436	A 2 △
38	0,0137	A 2 ○	24	0,0218	A 2 ○	22	0,0472	A 2 △

### TRANSVERSE

Z2			Z2			Z2		
52	0,0014	E 2 ○	44	0,0017	E 2 ○	52	0,0028	E 2 △
48	0,0015	E 2 ○	44	0,0019	C 3 △	48	0,0030	E 2 △
52	0,0016	C 3 △	38	0,0019	E 2 ○	44	0,0034	E 2 △
48	0,0017	C 3 △	38	0,0022	C 3 △	38	0,0038	E 2 △

Z2			Z2			Z2		
38	0,0013	B 5 ○	24	0,0035	C 3 ○	22	0,0058	A 2 ○
26	0,0019	B 5 ○	26	0,0038	B 5 △	26	0,0066	C 3 △
24	0,0020	B 5 ○	22	0,0039	C 3 ○	38	0,0066	A 2 △
22	0,0022	B 5 ○	24	0,0040	B 5 △	24	0,0070	C 3 △
38	0,0022	C 3 ○	22	0,0044	B 5 △	22	0,0078	C 3 △
38	0,0026	B 5 △	38	0,0044	C 3 △	26	0,0098	A 2 △
26	0,0033	C 3 ○	26	0,0049	A 2 ○	24	0,0106	A 2 △
38	0,0033	A 2 ○	24	0,0053	A 2 ○	22	0,0116	A 2 △

## THREADING CHART

T.P.I.

mm

Z1			Z2			Z2			Z2		
24	4	A 2 △	48	16	A 2 △	0,4	B 4 ○	1,6	B 4 ○		
24	4½	A 3 △	48	18	A 3 △	0,45	C 4 ○	1,8	C 4 ○		
24	5	A 4 △	38	19	C 3 △	0,5	C 3 ○	2	C 3 ○		
22	5½	C 3 △	48	20	A 4 △	0,6	A 4 ○	2,25	C 2 ○		
24	6	C 3 △	44	22	C 3 △	0,7	E 4 ○	2,4	A 4 ○		
26	6½	C 3 △	48	24	C 3 △	0,75	A 2 ○	2,5	D 2 ○		
24	7	A 5 △	52	26	C 3 △	0,8	B 4 △	2,8	E 4 ○		
24	7½	B 4 △	48	28	A 5 △	0,9	C 4 △	3	A 2 ○		
24	8	A 2 ○	48	30	B 4 △	1	C 3 △	3,2	B 4 △		
24	9	A 3 ○	48	32	A 2 ○	1,2	A 4 △	3,5	E 2 ○		
38	9½	C 3 △	48	36	A 3 ○	1,25	D 2 △	3,6	C 4 △		
24	10	A 4 ○	38	38	C 3 ○	1,4	E 4 △	4	C 3 △		
22	11	C 3 ○	48	40	A 4 ○	1,5	A 2 △	4,5	C 2 △		
24	12	C 3 ○	44	44	C 3 ○	1,75	E 2 △	4,8	A 4 △		
26	13	C 3 ○	48	48	C 3 ○			5	D 2 △		
24	14	A 5 ○	52	52	C 3 ○			5,6	E 4 △		
24	15	B 4 ○	48	56	A 5 ○			6	A 2 △		
38	19	C 3 ○	48	60	B 4 ○			7	E 2 △		

## THREAD

### THREAD DIAL

T.P.I.	Dial
4	12 20
28	36 44
52	
6	10 14
18	22 26
30	38
5	7 9
11	13 15
19	
4½	5½ 6½
7½	9½
8	16 24
32	40 48
56	

### THREADING DIAGRAM

Table 3

# 13.0 Replacement parts

Replacement parts are listed on the following pages. To order parts or reach our service department, call 1-800-274-6848 Monday through Friday, 8:00 a.m. to 5:00 p.m. CST. Having the Model Number and Serial Number of your machine available when you call will allow us to serve you quickly and accurately.

Non-proprietary parts, such as fasteners, can be found at local hardware stores, or may be ordered from JET. Some parts are shown for reference only, and may not be available individually.

## 13.1.1 Bed Assembly – Exploded View

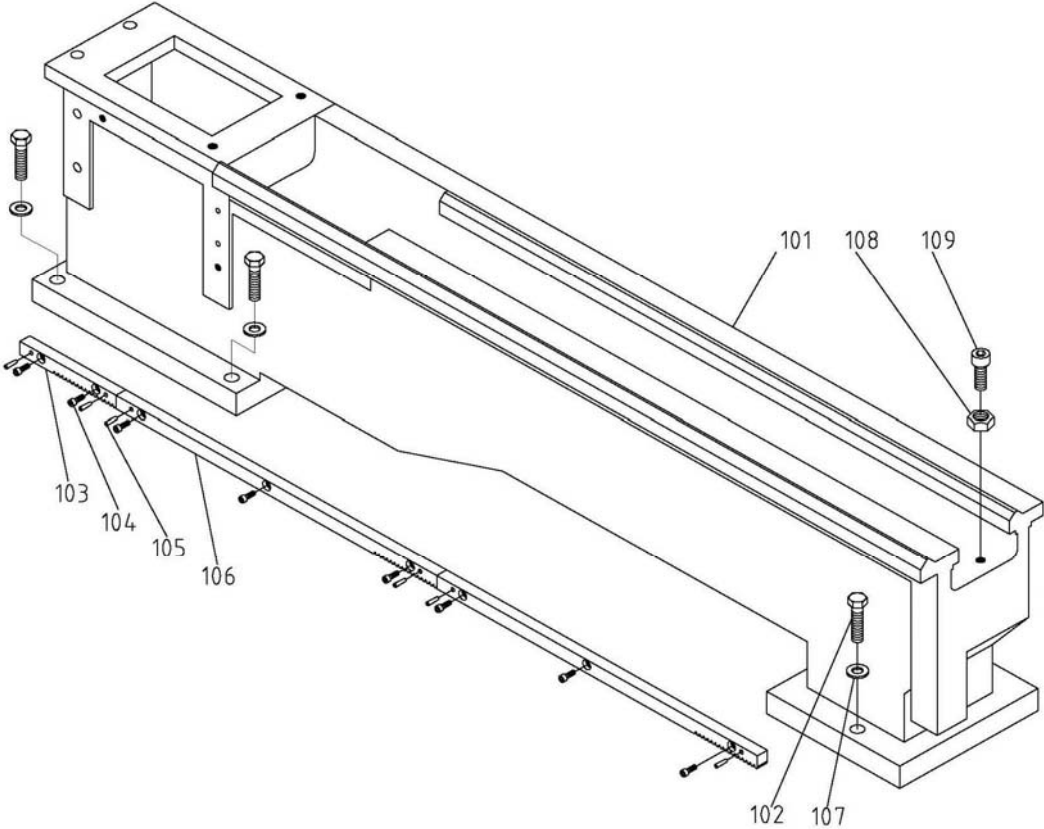

## 13.1.2 Bed Assembly – Parts List

Index No.	Part No.	Description	Size	Qty
101	GHB1236-101	Lathe Bed		1
102	TS-1492041	Hex Cap Screw	M12X40	6
103	GHB1236-103	Rack Gear		1
104	JJP8BT-123	Hex Socket Hd Cap Screw	M6X15	6
105	ZX-H218	Taper Pin	6X25MM	6
106	GHB1236-106	Rack		2
107	TS-2360121	Flat Washer	12MM	6
108	TS-1540081	Hex Nut	M12	1
109	TS-1506041	Hex Socket Hd Cap Screw	M12X35	1

### 13.2.1 Headstock Assembly – Exploded View

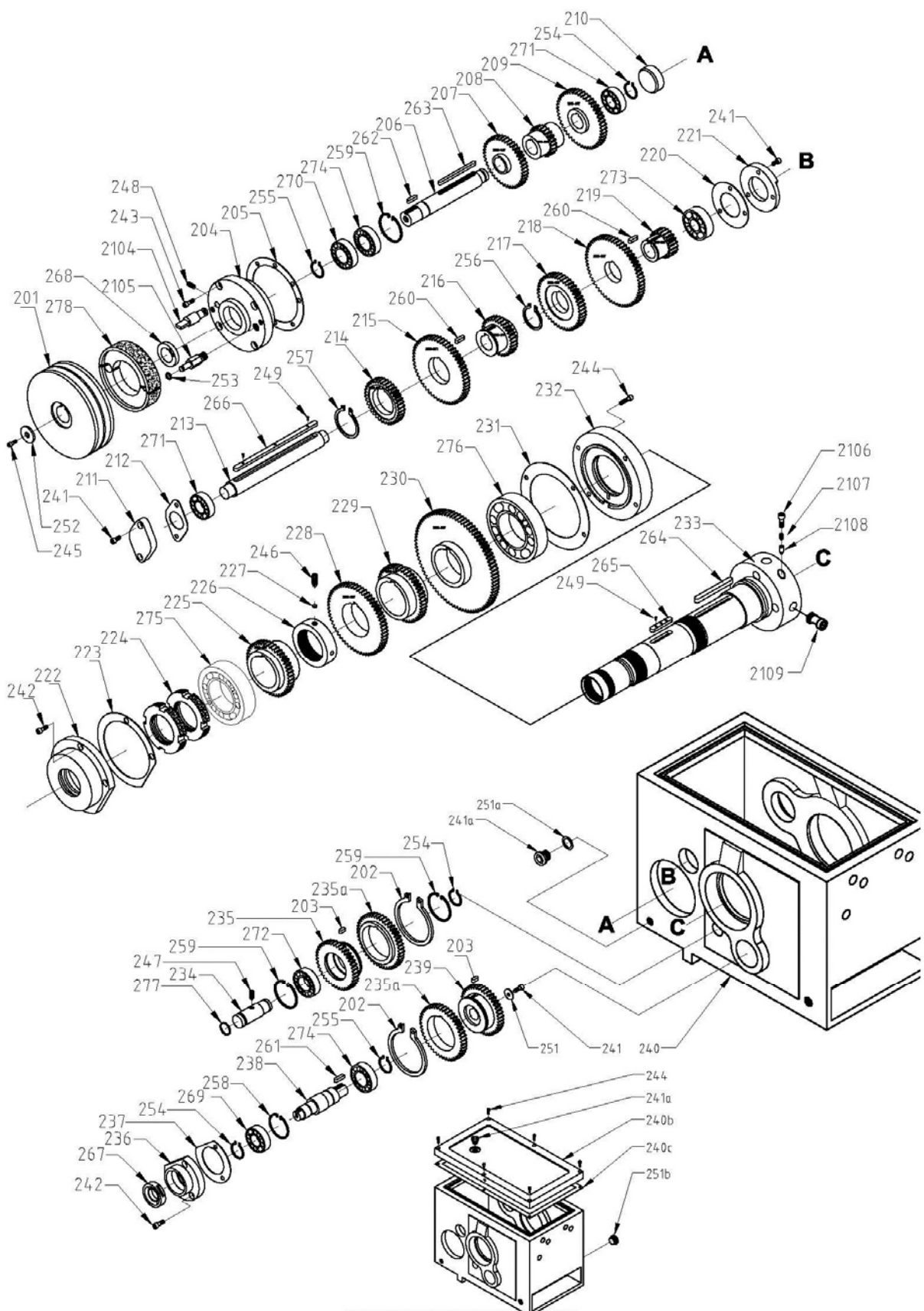

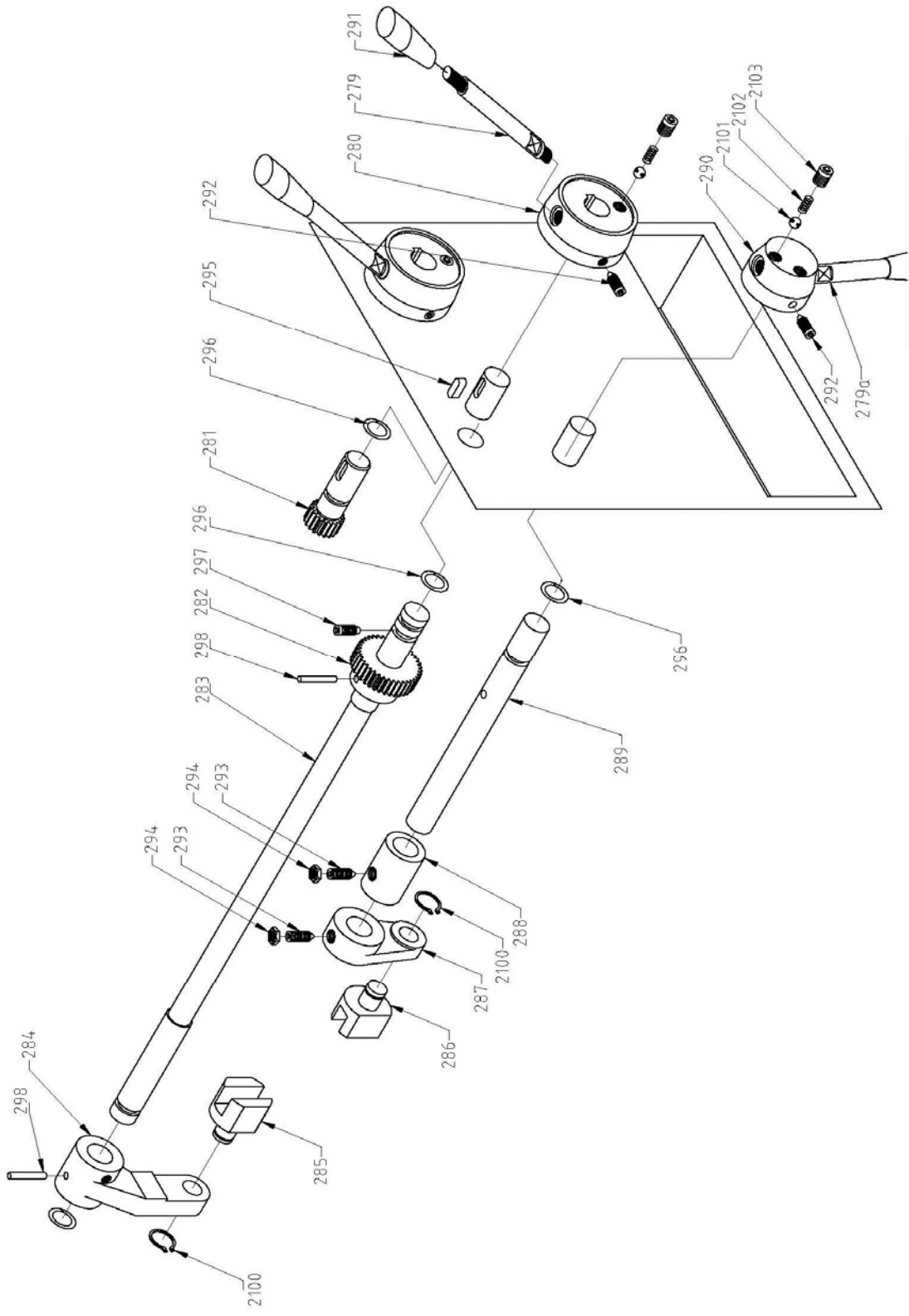

### 13.2.2 Headstock Assembly – Parts List

Index No.	Part No.	Description	Size	Qty
201	GHB1236-201	Pulley	155x42	1
202	F006057	C-Retaining Ring, Ext	60mm	2
203	MFC1000-35	Key, Double Rd Hd	A5x12MM	2
204	GHB1236-204	Cover		1
205	GHB1236-205	Gasket		1
206	GHB1236-206	Shaft		1
207	GHB1236-207	Gear	42T	1
208	GHB1236-208	Gear	23T	1
209	GHB1236-209	Gear	47T	1
210	GHB1236-210	Cover		1
211	GHB1236-211	Cover		1
212	GHB1236-212	Gasket		1
213	GHB1236-213	Shaft		1
214	GHB1236-214	Gear	36T	1
215	GHB1236-215	Gear	55T	1
216	GHB1236-216	Gear	31T	1
217	GHB1236-217	Gear	45T	1
218	GHB1236-218	Gear	58T	1
219	GHB1236-219	Gear	21T	1
220	GHB1236-220	Gasket		1
221	GHB1236-221	Cover		1
222	GHB1236-222	Cover		1
223	GHB1236-223	Gasket		1
224	GHB1236-224	Nut		2
225	GHB1236-225	Gear	45T	1
226	GHB1236-226	Nut		1
227	GHB1236-227	Collar	6X2	1
228	GHB1236-228	Gear	59T	1
229	GHB1236-229	Gear	46T	1
230	GHB1236-230	Gear	83T	1
231	GHB1236-231	Gasket		1
232	GHB1236-232	Cover		1
233	GHB1236-233	Spindle		1
234	GHB1236-234	Shaft		1
235	GHB1236-235	Gear	40T	1
235a	GHB1236-235A	Gear	45T	2
236	GHB1236-236	Cover		1
237	GHB1236-237	Washer		1
238	GHB1236-238	Shaft		1
239	GHB1236-239	Gear	40T	1
240	GHB1236-240	Headstock Casting		1
240b	GHB1236-240B	Cover		1
240c	GHB1236-240C	Washer		1
241	TS-1503031	Hex Socket Hd Cap Screw	M6X12	6
241a	GHB1236-241A	Oil Sight Glass	M16X1.5	2
242	TS-1503041	Hex Socket Hd Cap Screw	M6X16	7
243	TS-1503051	Hex Socket Hd Cap Screw	M6X20	4
244	TS-1503061	Hex Socket Hd Cap Screw	M6X25	10
245	TS-1504041	Hex Socket Hd Cap Screw	M8X20	1
246	TS-1524011	Socket Set Screw	M8X8	2
247	F010404	Socket Set Screw CP	M6X16	1
248	TS-1522041	Socket Set Screw	M5X12	1
249	TS-1531022	Phillips Pan Hd Mach Screw	M3X8	4
251	TS-1550041	Washer	6MM	1
251a	GHB1236-251A	Copper Washer	16MM	1
251b	GHB1236-251B	Oil Seal	M22X1.5	1
252	TS-1550061	Flat Washer	8MM	1
253	F006039	C-Retaining Ring, Ext	8MM	1
254	5507632	C-Retaining Ring, Ext	20MM	3
255	5507633	C-Retaining Ring, Ext	25MM	2

Index No.	Part No.	Description	Size	Qty
256	F006081	C-Retaining Ring, Ext	36MM	1
257	F006056	C-Retaining Ring, Ext	45MM	1
258	F006077	C-Retaining Ring, Int	42MM	1
259	F006075	C-Retaining Ring, Int	47MM	3
260	GHD20PF-379	Key, Double Rd Hd	A5x28	2
261	GHB1236-261	Key, Spcl.	C5x20	1
262	GHB1236-262	Key, Spcl.	C5x24	1
263	HVBS710SG-307	Key, Double Rd Hd	A5x80	1
264	JWL1640EVS-113	Key, Double Rd Hd	A8x80	1
265	GHB1236-265	Key, Double Rd Hd	A8x45	1
266	GHB1236-266	Key, Double Rd Hd	A8x180	1
267	GHB1236-267	Oil seal	20X40X10MM	1
268	GHB1236-268	Oil seal	25X40X10MM	1
269	BB-6004Z	Bearing	6004-Z	1
270	BB-6005Z	Bearing	6005-Z	1
271	BB-6004	Bearing	6004	2
272	BB-6204	Bearing	6204	1
273	BB-6304	Bearing	6304	1
274	BB-6005	Bearing	6005	2
275	BB-30211	Bearing	30211/P5	1
276	BB-30212	Bearing	30212/P5	1
277	GHB1236-277	Oil seal	22x2.4mm	1
278	GHB1236-278	Pulley Brake Assembly	25x125	1
279	GHB1236-279	Handle		2
279a	GHB1236-279A	Handle		1
280	GHB1236-280	Boss		2
281	GHB1236-281	Gear	19T	2
282	GHB1236-282	Gear	38T	2
283	GHB1236-283	Shaft		2
284	GHB1236-284	Shaft Arm		2
285	GHB1236-285	Shift Fork		2
286	GHB1236-286	Shift Fork		1
287	GHB1236-287	Shaft arm		1
288	GHB1236-288	Collar		1
289	GHB1236-289	Shaft		1
290	GHB1236-290	Boss		1
291	GHB1236-291	Handle Grip	M8X40	3
292	TS-1523061	Socket Set Screw CP	M6X20	3
293	TS-1524041	Socket Set Screw CP	M8X16	2
294	GHB1236-294	Hex Thin Nut	M8	2
295	50605005	Key, Double Rd Hd	A5X14	2
296	GHB1236-296	Oil seal	16X2.4mm	7
297	F010438	Socket Set Screw DP	M6X16	2
298	ZX-T36	Taper Pin	6X32	4
2100	GHD20PF-97	C-Retaining Ring, Ext	12MM	3
2101	SB-6MM	Steel Ball	6MM	4
2102	GHB1236-2102	Spring	1.2X5X14mm	4
2103	F010439	Socket Set Screw FP	M8X8	4
2104	GHB1236-2104	Shaft		1
2105	CGHB1236-2105	Rocker Pin		1
2106	TS-1504031	Hex Socket Hd Cap Screw	M8X16	3
2107	GHB1236-2107	Spring	4.5x16x0.8mm	3
2108	GHB1236-2108	Cam Pin		3
2109	GHB1236-2109	Cam		3

13.3.1 Gearbox Assembly – Exploded View

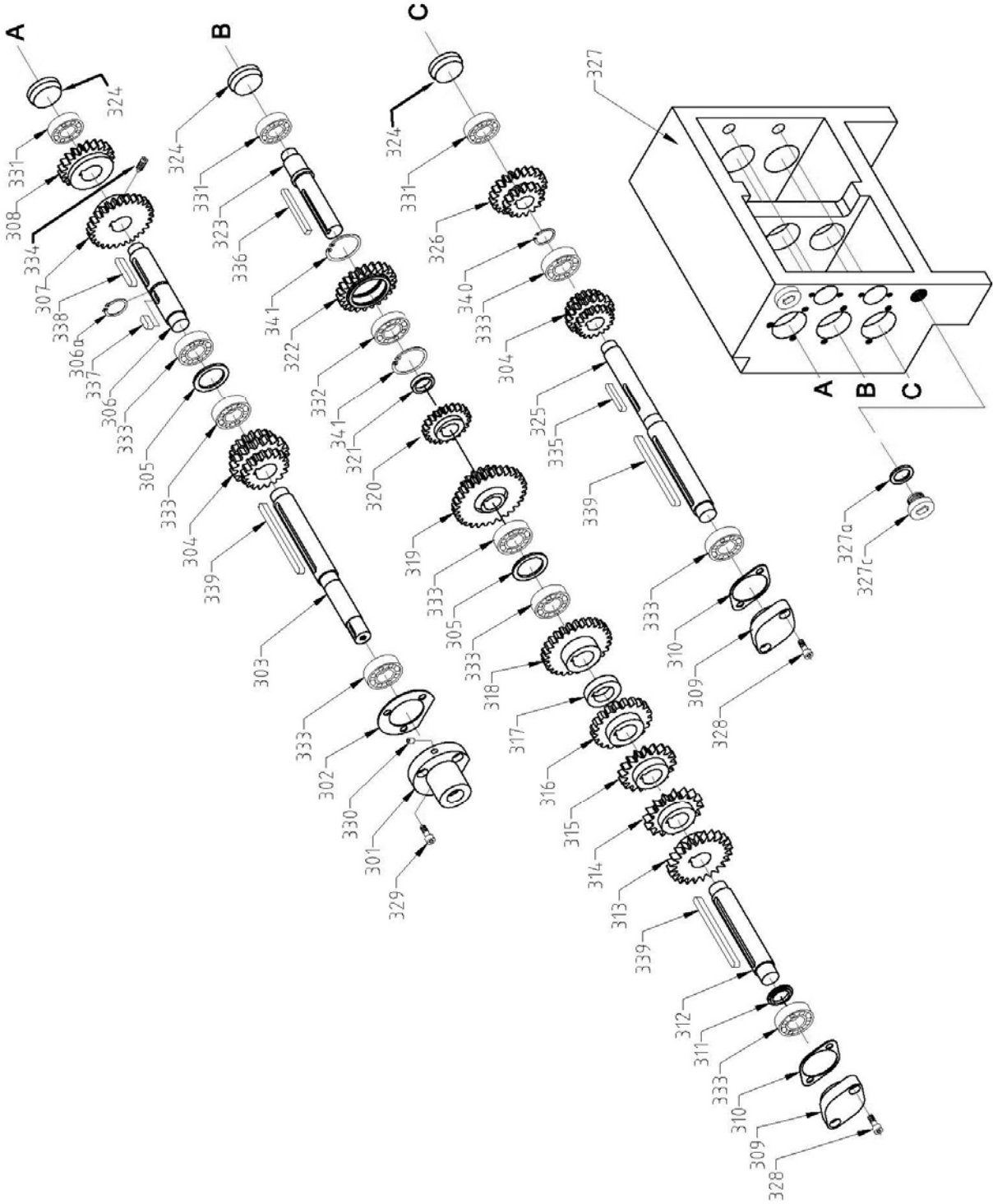

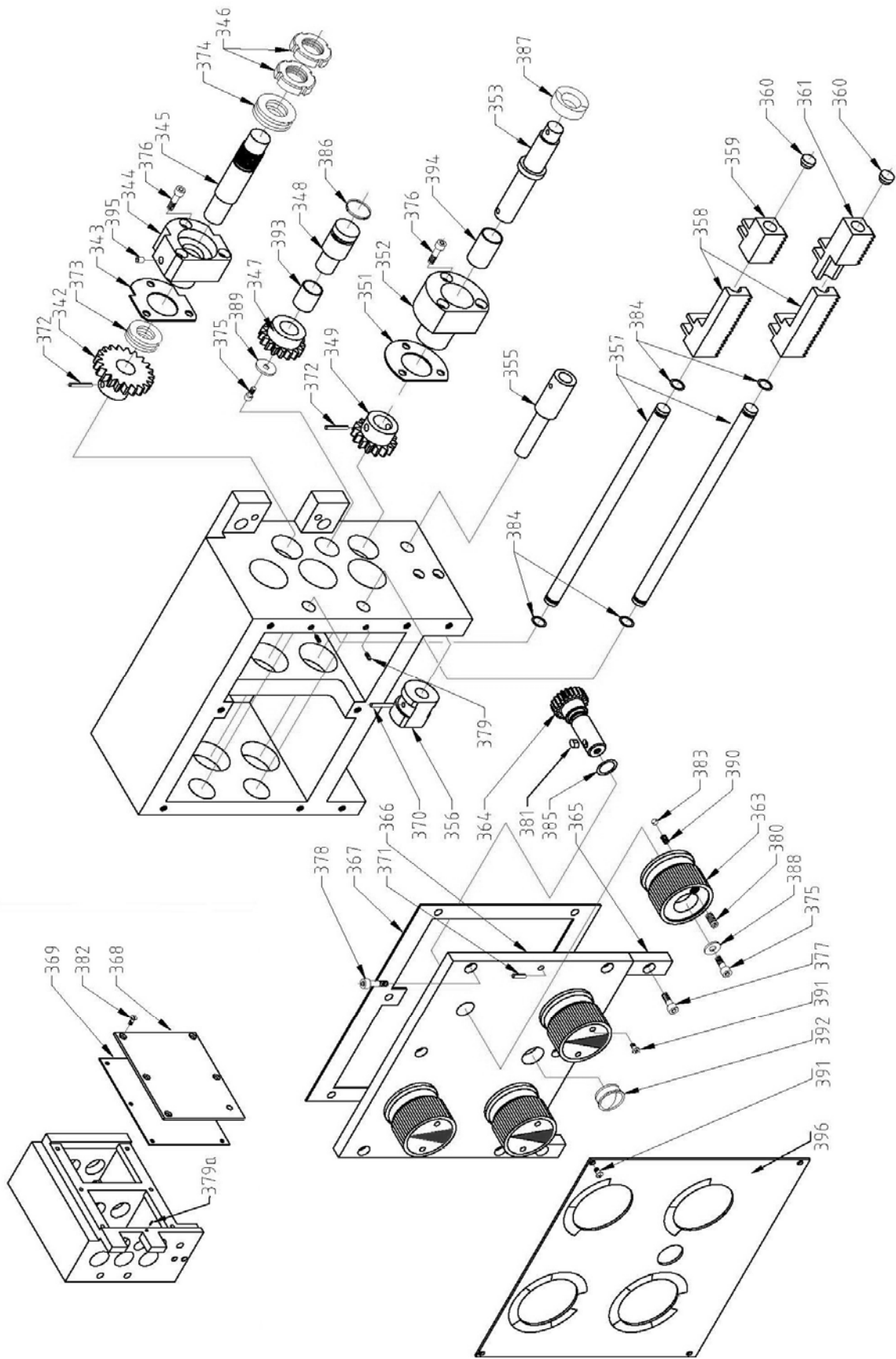

### 13.3.2 Gearbox Assembly – Parts List

Index No.	Part No.	Description	Size	Qty
301	GHB1236-301	Cover		1
302	GHB1236-302	Oil Seal		1
303	GHB1236-303	Shaft		1
304	GHB1236-304	Compound Gear	18T/18T/18T	2
305	GHB1236-305	Washer		2
306	GHB1236-306	Shaft		1
306a	AB1012W-F13	C-Retaining Ring, Ext	20MM	1
307	GHB1236-307	Gear	27T	1
308	GHB1236-308	Gear	21T	2
309	GHB1236-309	Cover		2
310	GHB1236-310	Oil Seal		2
311	GHB1236-311	Washer		1
312	GHB1236-312	Shaft		1
313	GHB1236-313	Gear	24T	1
314	GHB1236-314	Gear	16T	1
315	GHB1236-315	Gear	18T	1
316	GHB1236-316	Gear	20T	1
317	GHB1236-317	Washer		1
318	GHB1236-318	Gear	28T	1
319	GHB1236-319	Compound Gear	30T/18T	1
320	GHB1236-320	Gear	22T	1
321	GHB1236-321	Washer		1
322	GHB1236-322	Gear	23T	1
323	GHB1236-323	Shaft		1
324	GHB1236-324	Cap		3
325	GHB1236-325	Shaft		1
326	GHB1236-326	Gear	22T/15T	1
327	GHB1236-327	Gear Box Casting		1
327a	GHB1236-327A	Copper Washer	16mm	2
327c	GHB1236-327C	Oil Plug	M16X1.5	2
328	TS-1503031	Hex Socket Hd Cap Screw	M6X12	4
329	TS-1503041	Hex Socket Hd Cap Screw	M6X16	3
330	BDB919-021	Oil Port	6MM	1
331	BB-6002	Bearing	6002	3
332	BB-16003	Bearing	16003	1
333	BB-6003	Bearing	6003	8
334	TS-2276081	Socket Set Screw	M6X8	1
335	EGH1740-B62	Key, Double Rd Hd	A5x35	1
336	5303911	Key	C5X40	1
337	EGH1880-G19	Key, Double Rd Hd	A6x15	1
338	JWBS14SF-216	Key, Double Rd Hd	A6x35	1
339	E1340VS-A119	Key, Double Rd Hd	A6x90	3
340	HVBS7M-219B	C-Retaining Ring, Ext	17MM	1
341	EBL1236VS-G81	C-Retaining Ring, Int	35MM	2
342	GHB1236-342	Gear	21T	1
343	GHB1236-343	Oil seal		1
344	GHB1236-344	Cover		1
345	GHB1236-345	Shaft		1
346	GHB1236-346	Nut		2
347	GHB1236-347	Gear	17T	1
348	GHB1236-348	Shaft		1
349	GHB1236-349	Gear	15T	1
351	GHB1236-351	Oil Seal		1
352	GHB1236-352	Cover		1
353	GHB1236-353	Shaft		1
355	GHB1236-355	Shaft		1
356	GHB1236-356	Position Piece		1
357	GHB1236-357	Shaft		2
358	GHB1236-358	Gear Rack		2
359	GHB1236-359	Gear Rack		1

Index No.	Part No.	Description	Size	Qty
360	GHB1236-360	Cover		2
361	GHB1236-361	Gear Rack		1
363	GHB1236-363	Boss		4
364	GHB1236-364	Gear	23T	4
365	GHB1236-365	Block		2
366	GHB1236-366	Cover		1
367	GHB1236-367	Gasket		1
368	GHB1236-368	Cover		1
369	GHB1236-369	Gasket		1
370	Y31126180	Roll Pin	4X28	1
371	992322	Roll Pin	5X26	2
372	5F-E208	Roll Pin	5X28	2
373	BB-51103	Bearing	51103	1
374	BB-51104	Bearing	51104	1
375	TS-1503031	Hex Socket Hd Cap Screw	M6X12	5
376	TS-1503061	Hex Socket Hd Cap Screw	M6X25	6
377	TS-1504031	Hex Socket Hd Cap Screw	M8X16	2
378	TS-1504041	Hex Socket Hd Cap Screw	M8X20	6
379	TS-1521031	Socket Set Screw CP	M4X8	2
379a	TS-1522021	Socket Set Screw CP	M5X8	1
380	F010440	Socket Set Screw FP	M8X6	4
381	KF2R5508	Key, Double Rd Hd	A5X8	4
382	5515754	Phillips Flat Hd Mach Screw	M6X10	6
383	SB-6MM	Steel Ball	6MM	4
384	GHB1236-384	O-Ring	12X1.8	4
385	GHB1236-385	O-Ring	16X2.4	4
386	GHB1236-386	O-Ring	22X2.4	1
387	GHB1236-387	Oil seal	18X30X10	1
388	TS-1550041	Flat Washer	M6	4
389	GHB1236-389	Flat Washer, Lg	M6	1
390	GHB1236-390	Spring	6X18X0.8	4
391	GHB1236-391	Phillips Pan Hd Mach Screw	M4X6	12
392	BDB919-606	Oil Sight Glass	M22X1.5	1
393	GHB1236-393	Copper Bushing	16X18X20	1
394	GHB1236-394	Copper Bushing	17X19X30	1
395	BDB919-021	Ball Oiler	6MM	1
396	GHB1236-396	Gear Box Plate		1

### 13.4.1 Apron Assembly – Exploded View

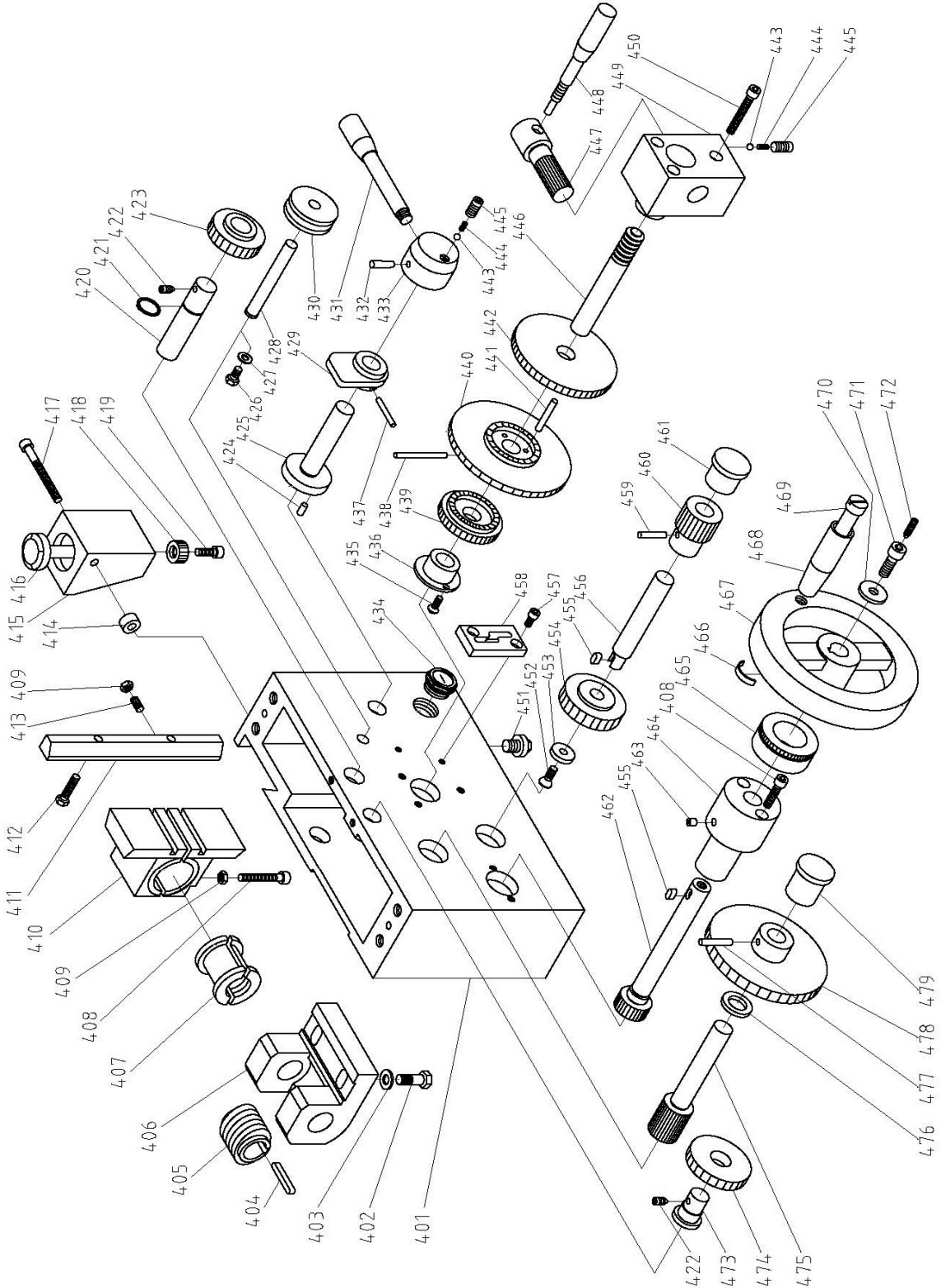

### 13.4.2 Apron Assembly – Parts List

Index No.	Part No.	Description	Size	Qty
401	GHB1236-401	Apron Casting		1
402	TS-1490051	Hex Cap Screw	M8X30	2
403	TS-1550061	Flat Washer	M8	1
404	3K00194	Key, Double Rd Hd	5X36MM	1
405	GHB1236-405	Worm		1
406	GHB1236-406	Bracket		1
407	GHB1236-407	Half Nut		1
408	TS-1503091	Hex Socket Hd Cap Screw	M6X40	3
409	TS-1540041	Hex Nut	M6	3
410	GHB1236-410	Bracket		1
411	GHB1236-411	Gib		1
412	TS-1482051	Hex Cap Screw	M6X25	2
413	A175A	Socket Set Screw	M6X15	2
414	GHB1236-414	Washer		1
415	GHB1236-415	Bracket		1
416	GHB1236-416	Shaft		1
417	GHB1236-417	Hex Socket Hd Cap Screw	M6X60	1
418	GHB1236-418	Gear		1
419	6286490	Hex Socket Hd Cap Screw	M6X15	1
420	GHB1236-420	Shaft		1
421	F006046	C-Retaining Ring, Ext	18MM	1
422	TS-1523011	Socket Set Screw CP	M6X6	2
423	GHB1236-423	Gear		1
424	F004035	Dowel Pin	5X10MM	2
425	GHB1236-425	Shaft		1
426	TS-1482011	Hex Cap Screw	M6X10	1
427	TS-1550041	Flat Washer	M6	1
428	GHB1236-428	Shaft		1
429	GHB1236-429	Locating Block		1
430	GHB1236-430	Grooved Disc		1
431	GHB1236-431	Lever		1
432	GB117-5X40	Taper Pin	5X40MM	1
433	GHB1236-433	Lever Hub		1
434	BDB919-606	Oil Sight Glass	M22X1.5	1
435	TS-1533042	Phillips Pan Hd Mach Screw	M5X12	2
436	GHB1236-436	Washer		1
437	WSS3-017	Roll Pin	4X30MM	1
438	F012094	Roll Pin	4X50MM	1
439	GHB1236-439	Gear		1
440	GHB1236-440	Gear		1
441	F004044	Dowel Pin	5X33MM	3
442	GHB1236-442	Gear		1
443	SB-6MM	Steel Ball	6MM	2
444	GHB1236-444	Spring		2
445	F010439	Socket Set Screw FP	M8X8	2
446	GHB1236-446	Shaft		1
447	GHB1236-447	Gear		1
448	GHB1236-448	Lever		1
449	GHB1236-449	Bracket		1
450	TS-1503101	Hex Socket Hd Cap Screw	M6X45	3
451	GHB1236-451	Oil Plug	M10X1	1
452	TS-2286121	Phillips Flat Hd Mach Screw	M6X12	1
453	GHB1236-453	Washer		1
454	GHB1236-454	Gear		1
455	GHD20PF-296	Key, Double Rd Hd	5X10	2
456	GHB1236-456	Shaft		1
457	TS-1502021	Hex Socket Hd Cap Screw	M5X10	2
458	GHB1236-458	Locating Block		1
459	D-11	Roll Pin	5X25	1
460	GHB1236-460	Gear		1

Index No.	Part No.	Description	Size	Qty
461	GHB1236-461	Cap		1
462	GHB1236-462	Shaft		1
463	BDB919-021	Ball Oiler	6MM	1
464	GHB1236-464	Bracket		1
465	GHB1236-465	Graduated Dial		1
466	GHB1236-466	Indicator		1
467	GHB1236-467	Handwheel		1
468	GHB1236-468	Handle		1
469	GHB1236-469	Handle screw		1
470	GHB1236-470	Washer		1
471	GHB1236-471	Screw		1
472	F010441	Socket Set Screw DP	5X30	1
473	GHB1236-473	Shaft		1
474	GHB1236-474	Gear		1
475	GHB1236-475	Shaft		1
476	GHB1236-476	Washer		1
477	ZX-S48	Roll Pin	5X30	1
478	GHB1236-478	Gear		1
479	GHB1236-479	Cap		1

### 13.5.1 Cross Slide Assembly – Exploded View

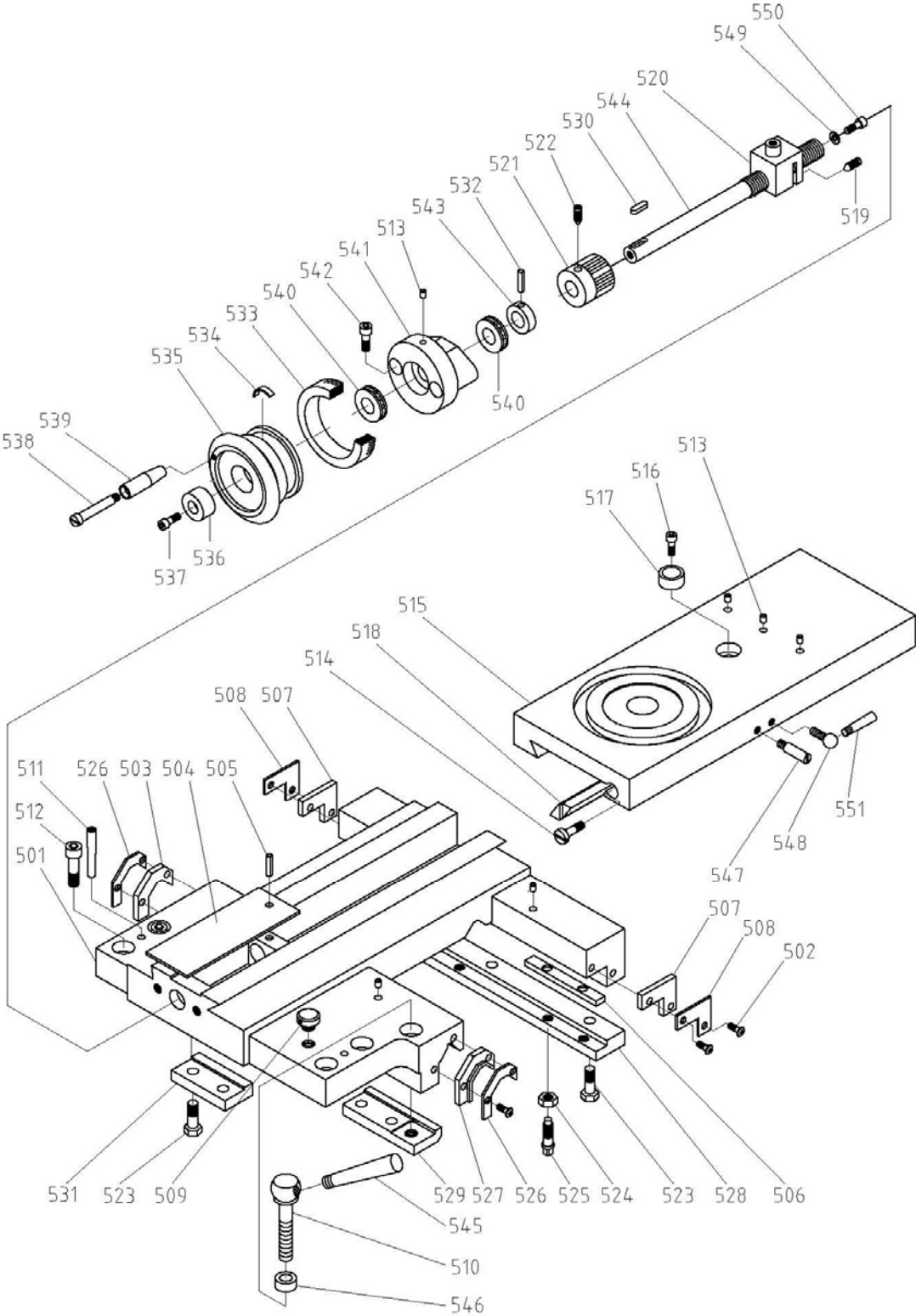

### 13.5.2 Cross Slide Assembly – Parts List

Index No.	Part No.	Description	Size	Qty
501	GHB1236-501	Saddle		1
502	TS-1533042	Phillips Pan Hd Mach Screw	M5X12	8
503	GHB1236-503	Wiper		1
504	GHB1236-504	Cover		1
505	6295178	Roll Pin	3X10MM	1
506	GHB1236-506	Press plate		2
507	GHB1236-507	Press plate		2
508	GHB1236-508	Wiper		1
509	GHB1236-509	Screw		1
510	GHB1236-510	Screw		1
511	GHB1236-511	Taper Pin	6X45MM	2
512	TS-1505041	Hex Socket Cap Screw	M10x30	4
513	BDB919-021	Ball Oiler	6MM	6
514	GHB1236-514	Screw		2
515	GHB1236-515	Tool post		1
516	TS-1503031	Hex Socket Cap Screw	M6x12	1
517	GHB1236-517	Bushing		1
518	GHB1236-518	Gib		1
519	TS-1521051	Socket Set Screw CP	M4x12	2
520	GHB1236-520	Nut		1
521	GHB1236-521	Gear		1
522	TS-2276081	Socket Set Screw CP	M6x8	1
523	TS-1490041	Hex Cap Screw	M8x25	7
524	TS-1540061	Hex Nut	M8	4
525	GHB1236-525	Screw, splcl	M8x25	4
526	GHB1236-526	Press plate		2
527	GHB1236-527	Wiper		1
528	GHB1236-528	Press Plate		1
529	GHB1236-529	Press Plate		1
530	5510675	Key, Double Rd Hd	5x20MM	1
531	GHB1236-531	Press Plate		1
532	PN04002408	Roll Pin	4X25MM	1
533	GHB1236-533	Index Ring		1
534	BDB919-711	Leaf Spring		1
535	GHB1236-535	Handwheel		1
536	GHB1236-536	Washer		1
537	TS-1503041	Hex Socket Cap Screw	M6x16	1
538	GHB1236-538	Handle screw		1
539	GHB1236-539	Handle		1
540	BB-51102	Bearing	51102	2
541	GHB1236-541	Bracket		1
542	TS-1504061	Hex Socket Cap Screw	M8x30	2
543	GHB1236-543	Collar		1
544	GHB1236-544	Guide Screw		1
545	GHB1236-545	Handle		1
546	GHB1236-546	Collar		1
547	GHB1236-547	Screw		1
548	GHB1236-548	Screw		1
549	TS-1550031	Flat Washer	M5	1
550	TS-1502031	Hex Socket Cap Screw	M5x12	1
551	GHB1236-551	Handle		1

### 13.6.1 Compound Rest Assembly – Exploded View

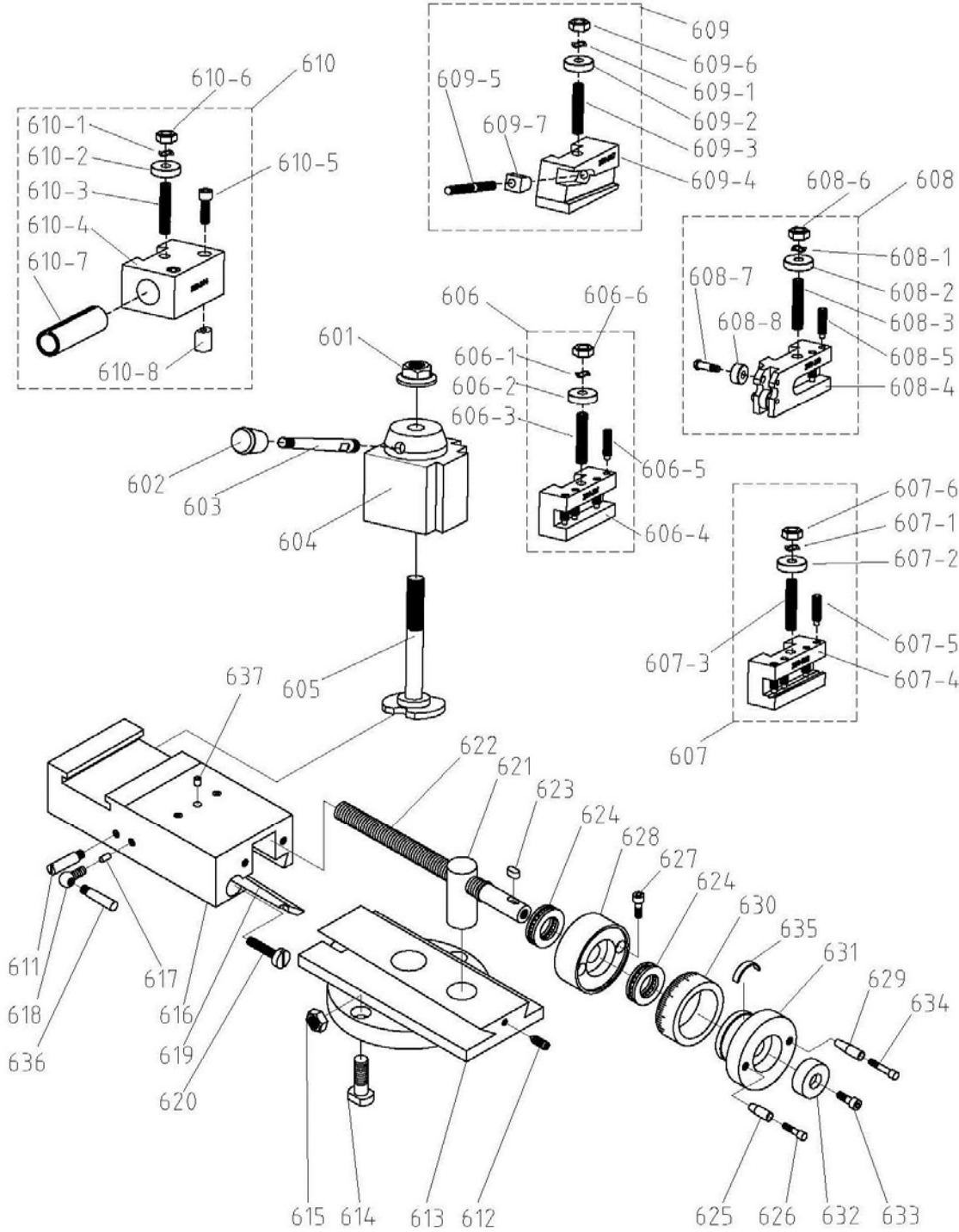

### 13.6.2 Compound Rest Assembly – Parts List

Index No.	Part No.	Description	Size	Qty
601	GHB1236-601	Flange Nut	M16	1
602	GHB1236-602	Handle		1
603	GHB1236-603	Lever		1
604	GHB1236-604	Quick Change Tool Post Body		1
605	GHB1236-605	Mounting Shaft		1
606	GHB1236-606	Turning Facing Holder		1
606-1		Wave Washer	10MM	1
606-2		Round Thumb Nut	10MM	1
606-3		Socket Set Screw	M10X45	1
606-4		Facing Holder		1
606-5		Socket Set Screw	M10X20	4
606-6		Hex Nut	M10	1
607	GHB1236-607	Turning Facing Boring Holder		1
607-1		Wave Washer	10MM	1
607-2		Round Thumb Nut	10MM	1
607-3		Socket Set Screw	M10X45	1
607-4		Boring Facing Holder		1
607-5		Socket Set Screw	M10X20	4
607-6		Hex Nut	M10	1
608	GHB1236-608	Knurling Facing Holder		1
608-1		Wave Washer	10MM	1
608-2		Round Thumb Nut	10MM	1
608-3		Socket Set Screw	M10X45	1
608-4		Knurling Holder		1
608-5		Socket Set Screw	M10X20	2
608-6		Hex Nut	M10	1
608-7		Roller Shaft		2
608-8		Idler Wheel		2
609	GHB1236-609	Universal Parting Blade Holder		1
609-1		Wave Washer	10MM	1
609-2		Round Thumb Nut	10MM	1
609-3		Socket Set Screw	M10X45	1
609-4		Parting Holder		1
609-5		Screw		1
609-6		Hex Nut	M10	1
609-7		Lock Nut		1
610	GHB1236-610	Heavy Duty Boring Bar Holder		1
610-1		Wave Washer	10MM	1
610-2		Round Thumb Nut	10MM	1
610-3		Socket Set Screw	M10X45	1
610-4		Boring Bar Holder		1
610-5		Hex Socket Cap Screw		1
610-6		Hex Nut	M10	1
610-7		Elastic Sleeve		1
610-8		Lock Nut		1
611	GHB1236-547	Screw		1
612	TS-1523051	Socket Set Screw CP	M6x16	1
613	GHB1236-613	Compound Base		1
614	GHB1236-614	T-Screw		2
615	TS-1540071	Hex Nut	M10	2
616	GHB1236-616	Compound		1
617	GHB1236-617	Pin		1
618	GHB1236-548	Screw		1
619	GHB1236-619	Gib		1
620	GHB1236-620	Screw		2
621	GHB1236-621	Nut		1
622	GHB1236-622	Guide Screw		1
623	JMD1-039	Key, Double Rd Hd	A4x8	1
624	BB-51101	Bearing	51101	2
625	GHB1236-625	Short Handle		1

626	GHB1236-626	Bolt.....	1
627	GHB1236-627	Hex Socket Hd Cap Screw..... M6x25	2
628	GHB1236-628	Bearing Housing.....	1
629	GHB1236-629	Long Handle.....	1
630	GHB1236-630	Index Ring.....	1
631	GHB1236-631	Handwheel.....	1
632	GHB1236-632	Washer.....	1
633	GHB1236-633	Hex Socket Cap Screw..... M6x12	1
634	GHB1236-634	Bolt.....	1
635	GHB1236-635	Leaf spring.....	1
636	GHB1236-551	Handle.....	1
637	BDB919-021	Ball Oiler..... 6MM	3

13.7.1 Tailstock Assembly – Exploded View

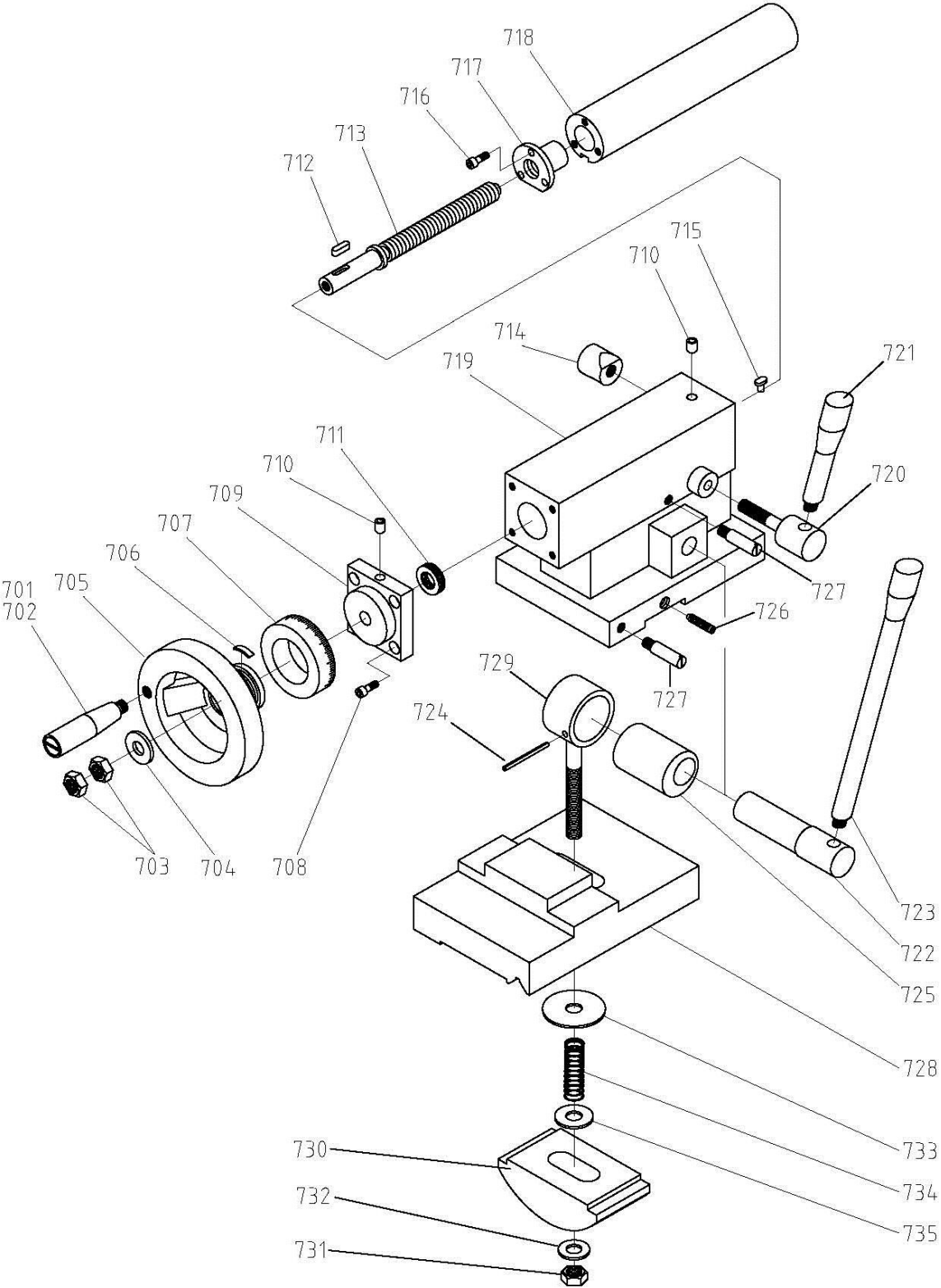

### 13.7.2 Tailstock Assembly – Parts List

Index No.	Part No.	Description	Size	Qty
701	GHB1236-701	Handle		1
702	GHB1236-702	Handle Screw		1
703	TS-1540071	Hex Nut	M10	2
704	TS-1550071	Flat Washer	M10	1
705	GHB1236-705	Handwheel		1
706	GHB1236-706	Leaf Spring		1
707	GHB1236-707	Index Ring		1
708	TS-1503041	Hex Socket Hd Cap Screw	M6X16	4
709	GHB1236-709	Bracket		1
710	BDB919-021	Ball Oiler	6MM	2
711	BB-51101	Bearing	51101	1
712	GHB1340-G100	Key, Double Rd Hd	A4X15	1
713	GHB1236-713	Lead Screw		1
714	GHB1236-714	Cam Lock Nut		1
715	GHB1236-715	Key, spcl		1
716	TS-1501041	Hex Socket Hd Cap Screw	M4x12	3
717	GHB1236-717	Nut		1
718	GHB1236-718	Quill		1
719	GHB1236-719	Tailstock Casting		1
720	GHB1236-720	Lock Screw		1
721	GHB1236-721	Handle		1
722	GHB1236-722	Shaft		1
723	GHB1236-723	Handle		1
724	GHB1340-116	Dowel Pin	5x30MM	1
725	GHB1236-725	Eccentric Collar		1
726	F010442	Socket Set Screw DP	M10x50	2
727	GHB1236-727	Screw		2
728	GHB1236-728	Tailstock Base		1
729	GHB1236-729	Collar		1
730	GHB1236-730	Base Shoe Black		1
731	TS-1540081	Hex Nut	M12	1
732	TS-2360121	Flat Washer	M12	1
733	GHB1236-733	Washer, spcl		1
734	GHB1236-734	Compression Spring		1
735	GHB1236-735	Washer, spcl		1

### 13.8.1 Change Gears – Exploded View

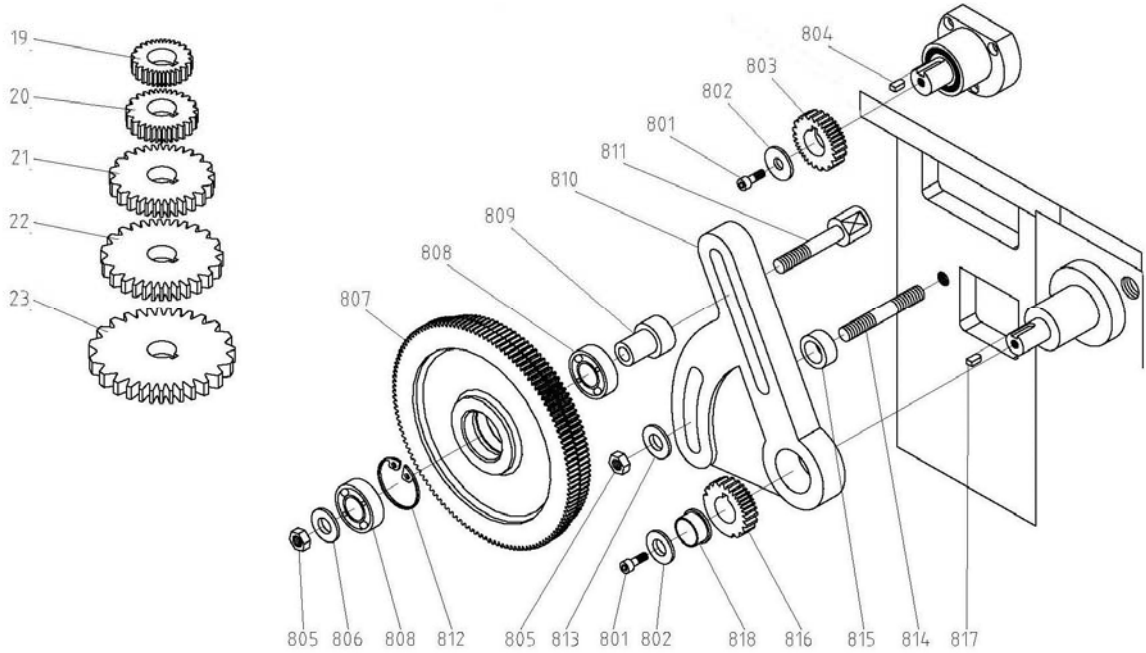

### 13.8.2 Change Gears – Parts List

Index No.	Part No.	Description	Size	Qty
801	GHB1236-801	Hex Socket Hd Cap Screw	M6X12	2
802	GHB1236-389	Flat Washer, Large	M6	2
803	GHB1236-803	Gear	24T	1
804	KF2R5508	Key, Double Rd Hd	A5X8	1
805	TS-1540071	Hex Nut	M10	2
806	TS-1550071	Flat Washer	M10	1
807	GHB1236-807	Compound Gear	120T/127T	1
808	BB-6003	Bearing	6003	2
809	GHB1236-809	Collar		1
810	GHB1236-810	Quadrant		1
811	GHB1236-811	Screw		1
812	F006033	C-Retaining Ring, Int	35MM	1
813	TS-1550071	Flat Washer	M10	1
814	GHB1236-814	Double End Stud	M10X60	1
815	GHB1236-815	Spacer		1
816	GHB1236-816	Gear	48T	1
817	KF2R5508	Key, Double Rd Hd	A5X8MM	1
818	GHB1236-818	Washer		1
819	GHB1236-819	Change gear	22T	1
820	GHB1236-820	Change gear	26T	1
821	GHB1236-821	Change gear	38T	1
822	GHB1236-822	Change gear	44T	1
823	GHB1236-823	Change gear	52T	1



### 13.9.2 Feed Rod Assembly – Parts List

Index No.	Part No.	Description	Size	Qty
901	GHB1236-901	Lead Screw		1
902	GHB1236-902	Rod		1
903	GHB1236-903	Bracket		1
904	GB117-6X45	Taper Pin	6X45MM	2
905	TS-1504121	Hex Socket Hd Cap Screw	M8X60	2
906	BDB919-021	Ball Oiler	6MM	2
907	SB-6MM	Steel Ball	6MM	5
908	TS-1523031	Socket Set Screw CP	M6x10	1
909	GHB1236-909	Collar		1
910	GHB1236-910	Feed Rod		1
911	GHB1236-911	Key, spcl		1
912	PN04002408	Roll Pin	4X25MM	1
913	GHB1236-913	Bracket		1
914	GHB1236-914	Spring	10X1X12MM	1
915	TS-1503031	Hex Socket Hd Cap Screw	M6X12	2
916	GHB1236-916	Bracket		1
917	GHB1236-917	Tapered Knob	M10X50	1
918	GHB1236-918	Handle		1
919	F006053	C-Retaining Ring, Ext	32MM	1
920	GHB1236-920	Spring	1x5x30MM	1
921	TS-1524011	Socket Set Screw	M8X8	5
922	GHB1236-922	Sleeve		1
923	PS042400	Roll Pin	4X24MM	1
923a	GHB1236-923A	Taper Pin	4X24MM	1
924	GHB1236-924	Shaft		1
925	BD920N-GB39	Roll Pin	4X20MM	1
926	AH25C-060	Roll Pin	4X30MM	1
927	GHB1236-927	Position Piece		1
928	JTS315-92	Phillips Pan Hd Mach Screw	M4X50	2
929	GHB1236-929	Switch	LXW5-11M	2
930	TS-2284202	Phillips Pan Hd Mach Screw	M4X20	2
931	GHB1236-931	Bracket		1
932	GHB1236-932	Cover		1
933	TS-1540021	Hex Nut	M4	4
934	PS040800	Roll Pin	4X12MM	1
935	D-11	Roll Pin	5X25MM	1
936	GHB1236-936	Clutch		1
938	GHB1236-938	Clutch		1
939	GHB1236-939	Spring	6x1x25MM	4
941	F012095	Roll Pin	4X42MM	1
942	TS-1523031	Socket Set Screw CP	M6X10	1
943	GHB1236-943	Cover		1
944	BB-51104	Bearing	51104	1

13.10.2 Motor and Change Gear Enclosure – Exploded View

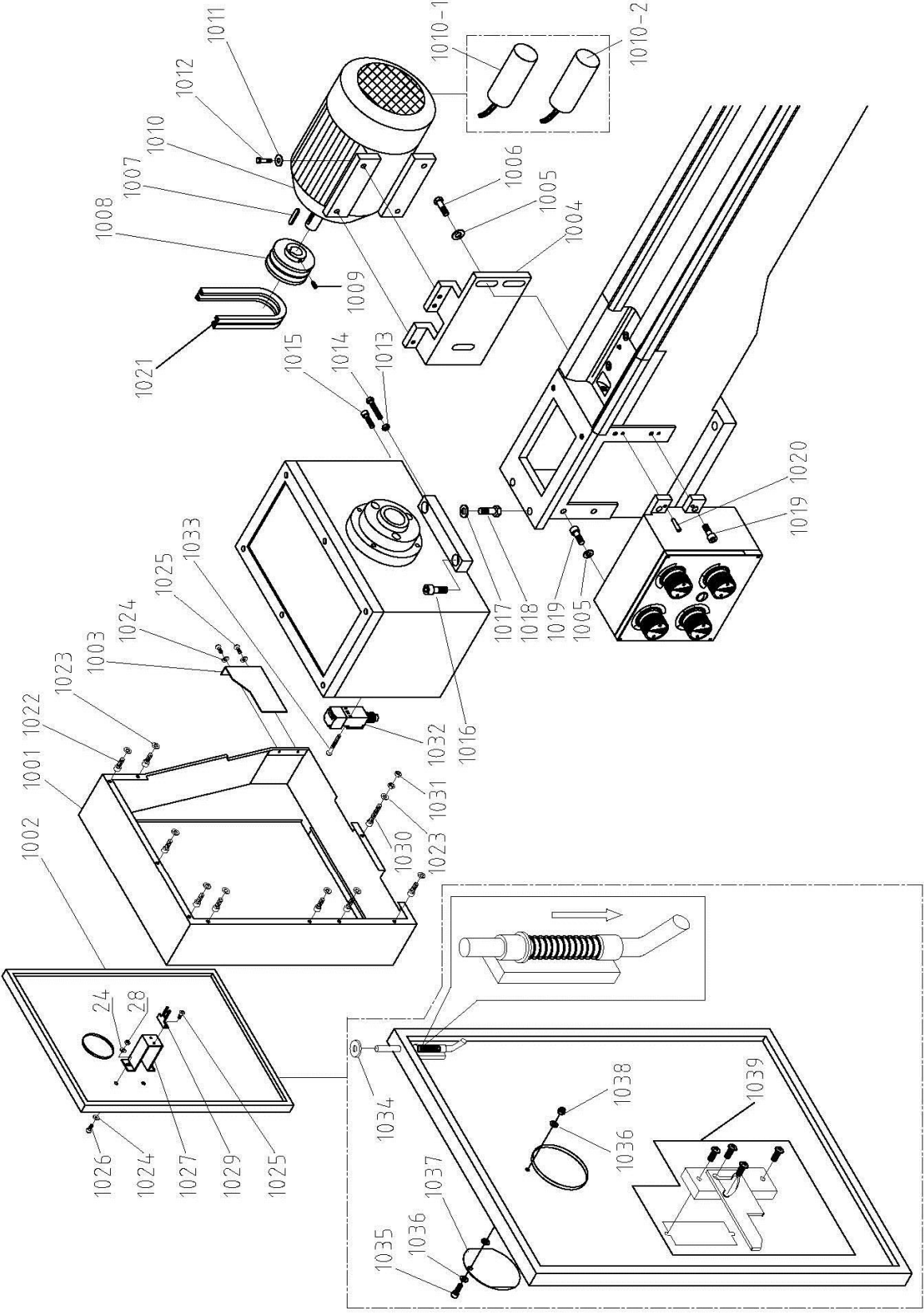

### 13.10.2 Motor and Change Gear Enclosure – Parts List

Index No.	Part No.	Description	Size	Qty
1001	GHB1236-1001	Change Gear Enclosure		1
1002	GHB1236-1002	Door		1
1003	GHB1236-1003	Motor Lower Cover		1
1004	GHB1236-1004	Motor Mounting Plate		1
1005	TS-1550071	Flat Washer	M10	5
1006	TS-1491041	Hex Cap Screw	M10X30	3
1007	ESN40-33-1	Key, Double Rd Hd	8X35MM	1
1008	GHB1236-1008	Pulley		1
1009	TS-2276081	Socket Set Screw CP	M6X8	1
1010	GHB1236-1010	Motor	2HP/230V/1PH	1
1010-1	GHB1236-1010-1	Start Capacitor	150MFD/250V	1
1010-2	GHB1236-1010-2	Run Capacitor	20mF/450V	1
1011	TS-1550061	Flat Washer	M8	4
1012	TS-1490041	Hex Cap Screw	M8X25	4
1013	TS-1540061	Hex Nut	M8	2
1014	TS-1490081	Hex Cap Screw	M8X45	2
1015	TS-1504061	Hex Socket Hd Cap Screw	M8X30	2
1016	TS-1506031	Hex Socket Hd Cap Screw	M12X30	2
1017	TS-2360121	Flat Washer	M12	2
1018	TS-1492031	Hex Cap Screw	M12X35	2
1019	TS-1505041	Hex Socket Hd Cap Screw	M10X30	4
1020	ZX-C34	Taper Pin	6X30MM	2
1021	VB-A813	V-Belt	A813	2
1022	TS-1503071	Hex Socket Hd Cap Screw	M6x30	8
1023	TS-1550031	Flat Washer	M5	9
1024	TS-1550021	Flat Washer	M4	6
1025	TS-2171012	Phillips Pan Hd Mach Screw	M4X6	4
1026	TS-1532032	Phillips Pan Hd Mach Screw	M4X10	2
1027	GHB1236-1027	Switch Bracket		1
1028	TS-1540021	Hex Nut	M4	2
1029	GHB1236-1029	Switch Key	QKS8-1	1
1030	TS-1502071	Hex Socket Hd Cap Screw	M5X30	1
1031	TS-1540031	Hex Nut	M5	2
1032	GHB1236-1032	Switch	QKS8-2	1
1033	TS-2284302	Phillips Pan Hd Mach Screw	M4X30	2
1034	TS-1550041	Flat Washer	M6	2
1035	TS-1503031	Hex Socket Hd Cap Screw	M6X12	1
1036	TS-1550041	Flat Washer	M6	3
1037	GHB1236-1037	Door Cover		1
1038	TS-1541021	Nylon Lock Hex Nut	M6	1
1039	GHB1236-1039	Door Latch Assy		1



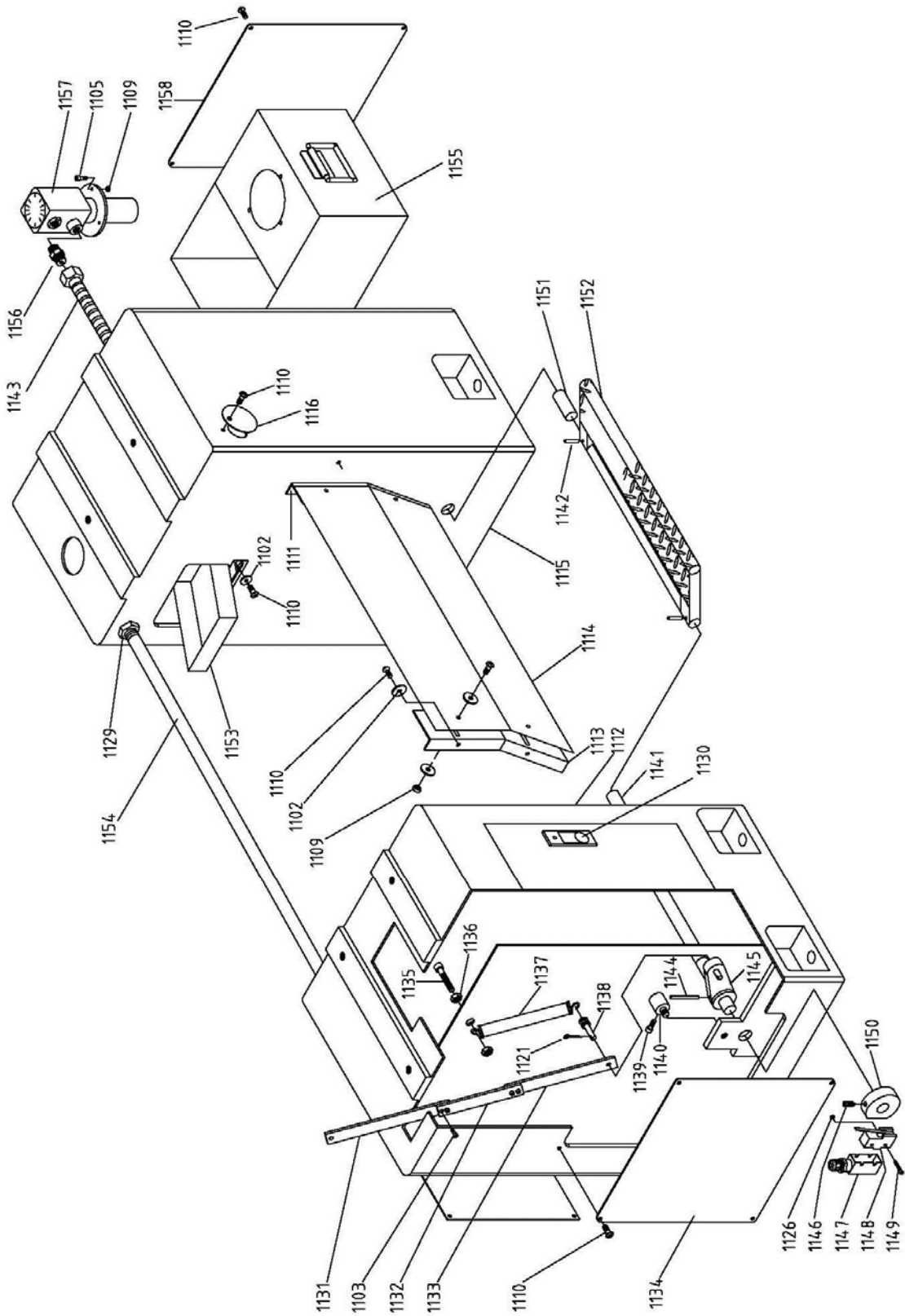

### 13.11.2 Stand/Brake/Coolant Pump – Parts List

Index No.	Part No.	Description	Size	Qty
1101	GHB1236-1101	Splash Guard		1
1102	TS-1550041	Flat Washer	M6	16
1103	TS-1503021	Hex Socket Hd Cap Screw	M6X10	4
1104	GHB1236-1104	Oil Pan		1
1105	TS-1503051	Hex Socket Hd Cap Screw	M6X20	5
1106	GHB1236-1106	Bracket		1
1107	JBOS5-56	Hex Socket Hd Cap Screw	M5X15	4
1108	GHB1236-1108	Work Lamp		1
1109	TS-1540041	Hex Nut	M6	10
1110	TS-1534032	Phillips Pan Hd Mach Screw	M6X10	26
1111	GHB1236-1111	Right Bracket		1
1112	GHB1236-1112	Left Cabinet		1
1113	GHB1236-1113	Left Bracket		1
1114	GHB1236-1114	Back Plate		1
1115	GHB1236-1115	Right Cabinet		1
1116	GHB1236-1116	Cover		4
1117	TS-1501011	Hex Socket Hd Cap Screw	M4X6	1
1118	GHB1236-1118	Coolant Hose Collar		1
1119	GHB1236-1119	Coolant Fitting		1
1120	GHB1236-1120	Coolant Nozzle		1
1121	GHB1236-1121	Cotter Pin	3X16MM	2
1122	D-11	Roll Pin	5X25MM	1
1123	GHB1236-1123	Clevis Pin		1
1124	GHB1236-1124	Rocker		1
1125	GHB1236-1125	Oil Tray		1
1126	TS-1534042	Phillips Pan Hd Mach Screw	M6X12	4
1127	TS-1550041	Flat Washer	M6	4
1128	GHB1236-1128	Handle		2
1129	GHB1236-1129	Nut	M16X1.5	1
1130	GHB1236-1130	Door Latch Assy		1
1131	GHB1236-1131	Brake Linkage/Upper		1
1132	GHB1236-1132	Brake Linkage/Middle		1
1133	GHB1236-1133	Brake Linkage/Lower		1
1134	GHB1236-1134	Cover		2
1135	TS-1505041	Hex Socket Hd Cap Screw	M10X30	1
1136	TS-1540071	Hex Nut	M10	2
1137	GHB1236-1137	Drawspring		1
1138	GHB1236-1138	Pin		1
1139	TS-1503091	Hex Socket Hd Cap Screw	M6X40	1
1140	GHB1236-1140	Shaft		1
1141	GHB1236-1141	Shaft		1
1142	3P12312	Roll Pin	5X28MM	4
1143	GHB1236-1143	Flexible Metal Tube	2M	1
1144	EHB916V-08-1	Roll Pin	5X40MM	1
1145	GHB1236-1145	Rocker		1
1146	TS-1523041	Socket Set Screw CP	M6X12	1
1147	GHB1236-1147	Limit Switch Cover		1
1148	GHB1236-1148	Limit Switch	YBLXW-5/11N1	1
1149	PS1652T-105	Phillips Pan Hd Mach Screw	M4X40	2
1150	GHB1236-1150	Rocker Cam		1
1151	GHB1236-1151	Shaft		1
1152	GHB1236-1152	Brake Pedal		1
1153	GHB1236-1153	Funnel		1
1154	GHB1236-1154	Steel Tube		1
1155	GHB1236-1155	Water Tank		1
1156	GHB1236-1156	Connector		1
1157	GHB1236-1157	Pump		1
1158	GHB1236-1158	Cover		1
	JET-138	JET Logo (not shown)	138x57 mm	1

13.12.1 Electrical Box Assembly – Exploded View

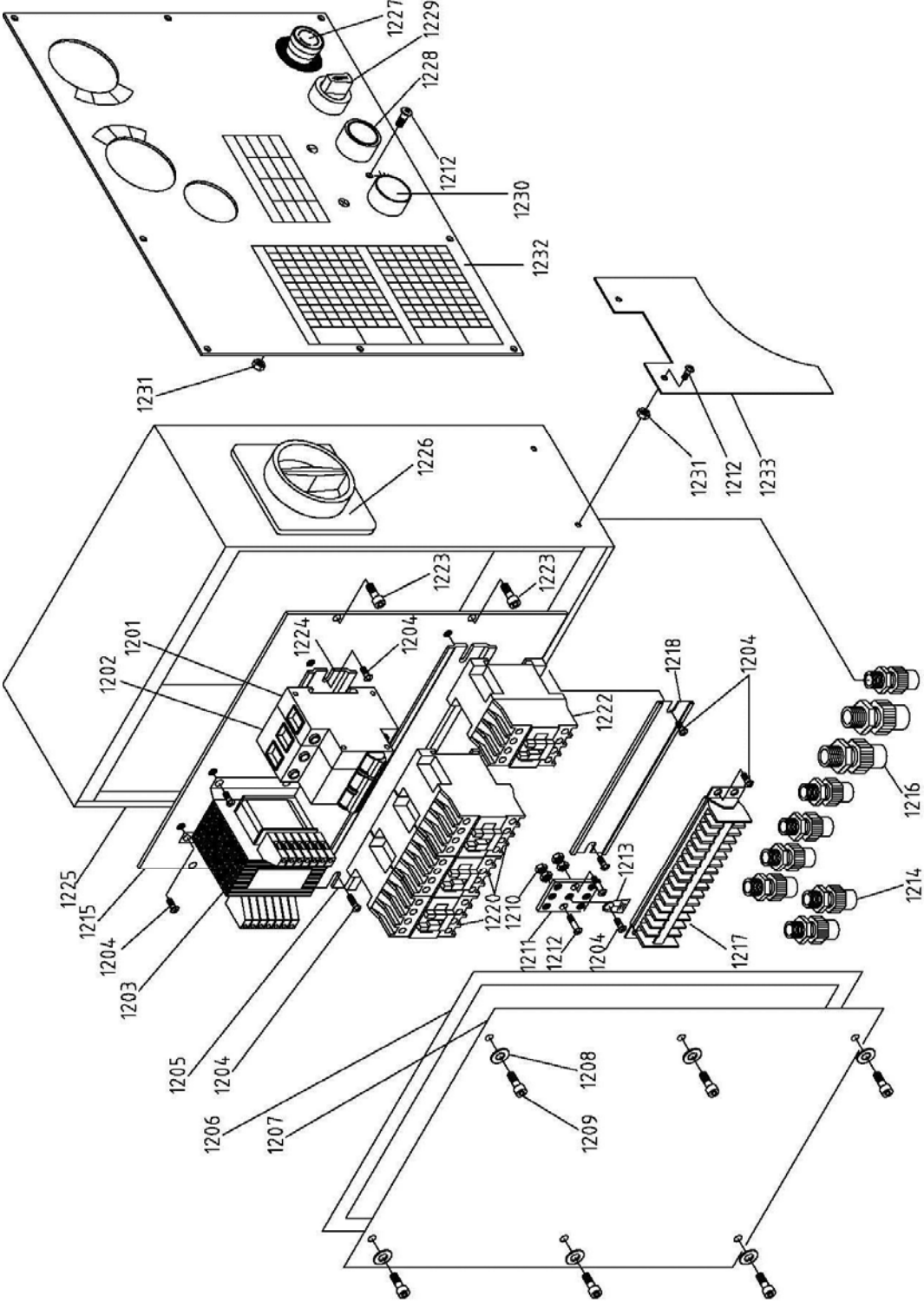

### 13.12.2 Electrical Box Assembly – Parts List

Index No.	Part No.	Description	Size	Qty
1201	GHB1236-1201	Circuit Breaker	DZ47-63 -1PC3	1
1202	GHB1236-1202	Circuit Breaker	DZ47-63-2PD16	1
1203	GHB1236-1203	Transformer	JBK5-100VA-TH	1
1204	TS-2171012	Phillips Pan Head Mach Screw	M4X6	15
1205	GHB1236-1205	Rail Clip		1
1206	GHB1236-1206	Rubber Cushing		4
1207	GHB1236-1207	Cover		1
1208	TS-1550021	Flat Washer	M4	6
1209	TS-1501031	Hex Socket Hd Cap Screw	M4x10	6
1210	TS-1540031	Hex Nut	M5	4
1211	GHB1236-1211	Copper Sheet		1
1212	TS-1532042	Phillips Pan Head Mach Screw	M4X12	5
1213	GHB1236-1213	Graphic Plate - Ground		1
1214	GHB1236-1214	Strain Relief	M16X1.5	5
1215	GHB1236-1215	Mounting Plate		1
1216	GHB1236-1216	Strain Relief	M20X1.5	2
1217	GHB1236-1217	DIN Rall Lower		1
1218	GHB1236-1218	Rail Clip		1
1220	GHB1236-1220	AC Contactor	CJX2S-0901-24V	3
1222	GHB1236-1222	Contactor Relay	JZC4-40-24V	1
1223	TS-1502031	Hex Socket Hd Cap Screw	M5X12	4
1224	GHB1236-1224	Rail Clip		1
1225	GHB1236-1225	Electric Box		1
1226	GHB1236-1226	Power Switch	LW26-20	1
1227	GHB1236-1227	E-Stop Button	XB2-BS545	1
1228	GHB1236-1228	Jog Button	LAY5-22D/23	1
1229	GHB1236-1229	Button switch	LAY3-11/2	
1230	GHB1236-1230	Power Light	AD62-22D/S 23/24V	1
1231	TS-1540021	Hex Nut	M4	3
1232	GHB1236-1232	Name Plate		1
1233	GHB1236-1233	Motor Upper Cover		1

### 13.13.1 Steady Rest and Follow Rest – Parts List

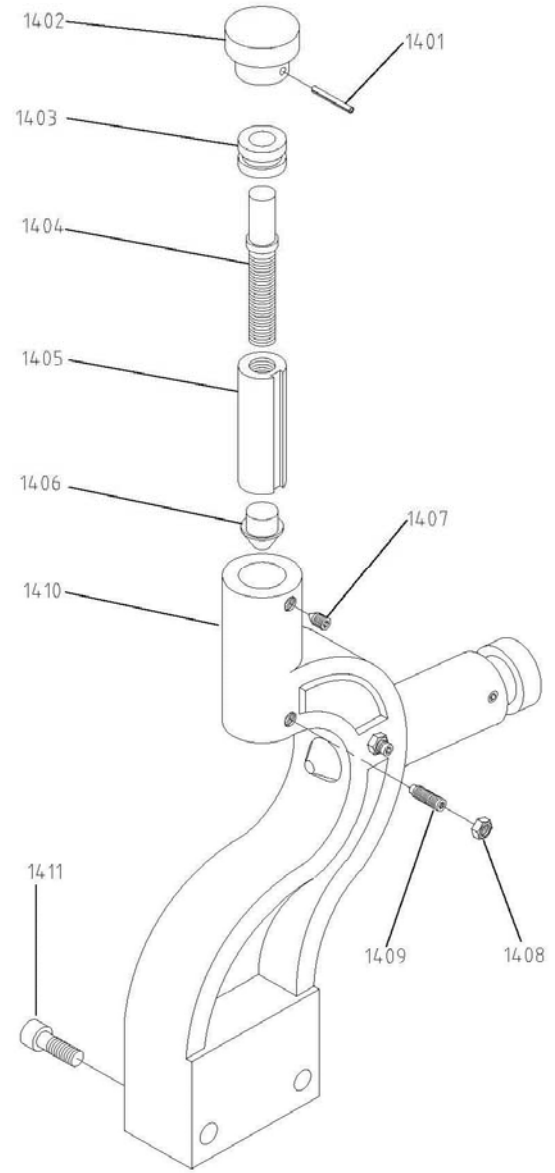
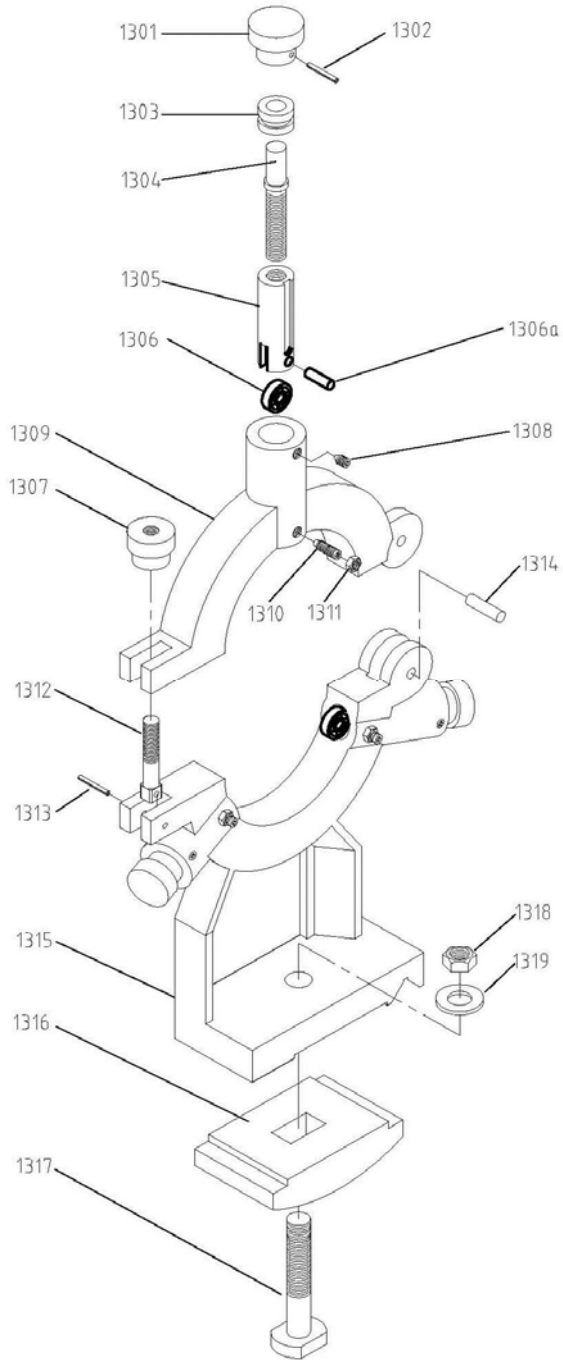

### 13.13.2 Steady Rest and Follow Rest – Parts List

Index No.	Part No.	Description	Size	Qty
1301	GHB1236-1301	Pinned Knob		3
1302	B-56	Roll Pin	3X20MM	3
1303	GHB1236-1303	Collar		3
1304	GHB1236-1304	Jack Screw		3
1305	GHB1236-1305	Finger Slide		3
1306	BB-625ZZ	Bearing	625ZZ	3
1306a	F004038	Dowel Pin	5X16MM	3
1307	GHB1236-1307	Knurled Thumb Knob		1
1308	TS-1523031	Socket Set Screw CP	M6X10	3
1309	GHB1236-1309	Steady Rest Upper Body		1
1310	F010438	Socket Set Screw DP	M6x16	3
1311	TS-1540041	Hex Nut	M6	3
1312	GHB1236-1312	Pivot Stud		1
1313	5217841	Roll Pin	4x20MM	1
1314	GB119-N6X20	Dowel Pin	6x20MM	1
1315	GHB1236-1315	Steady Rest Lower Body		1
1316	GHB1236-1316	Clamp Block		1
1317	GHB1236-1317	T-Bolt	M12X60	1
1318	TS-1540081	Hex Nut	M12	1
1319	TS-2360121	Flat Washer	M12	1
1401	TS-209203	Roll Pin	3X20MM	2
1402	GHB1236-1402	Pinned Knob		2
1403	GHB1236-1403	Collar		2
1404	GHB1236-1404	Jack Screw		2
1405	GHB1236-1405	Finger Slide		2
1406	GHB1236-1406	Brass Finger		2
1407	TS-1523031	Socket Set Screw CP	M6X10	2
1408	TS-1540041	Hex Nut	M6	2
1409	F010438	Socket Set Screw DP	M6x16	2
1410	GHB1236-1410	Follow Rest Body		1
1411	TS-1504081	Hex Socket Hd Cap Screw	M8x40	2

### 13.14.1 Chuck and Leadscrew Guards – Exploded View

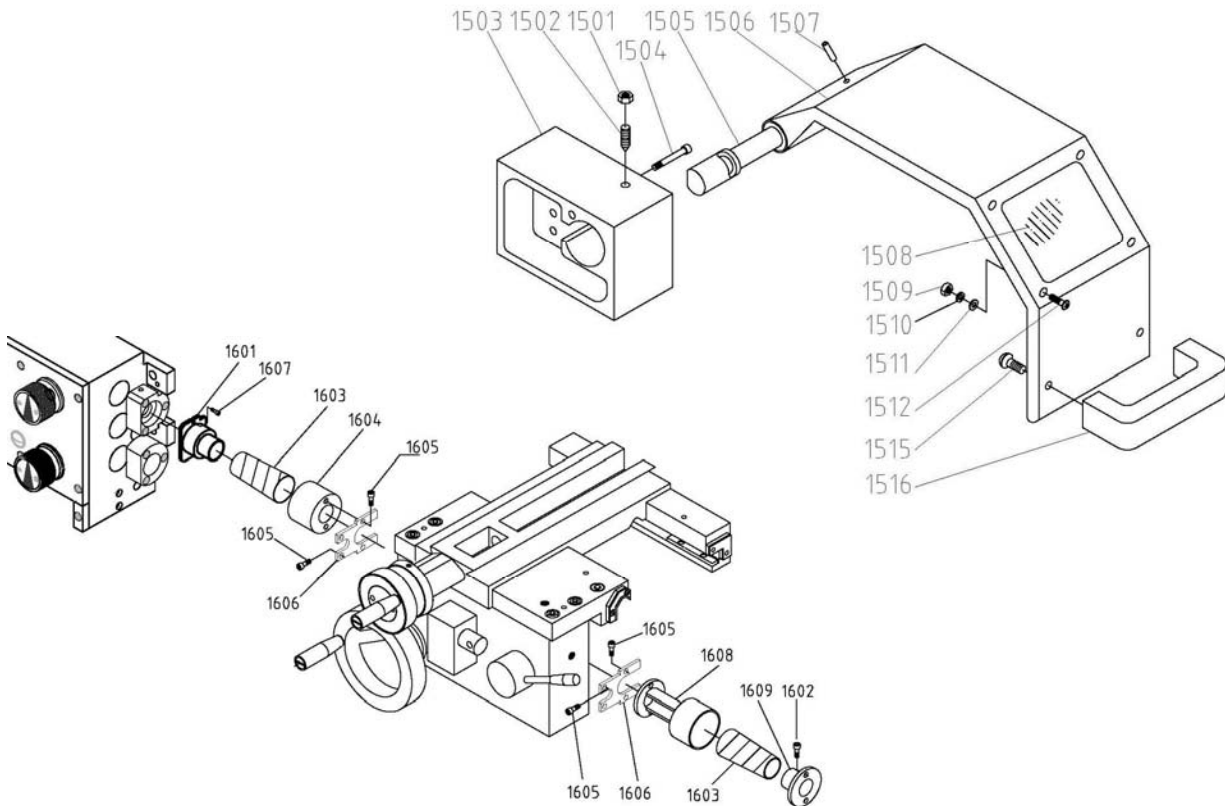

### 13.14.2 Chuck and Leadscrew Guards – Parts List

Index No.	Part No.	Description	Size	Qty
1501	TS-1540041	Hex Nut	M6	1
1502	F010438	Socket Set Screw DP	M6 x16	1
1503	GHB1236-1503	Switch Box		1
1504	TS-1503101	Hex Socket Hd Cap Screw	M6x 45	2
1505	GHB1236-1505	Shaft		1
1506	GHB1236-1506	Chuck Guard		1
1507	701-118	Roll Pin	4X25MM	1
1508	GHB1236-1508	Acrylic Sheet		1
1509	TS-1540011	Hex Nut	M3	4
1510	TS-2361031	Lock Washer	M3	4
1511	TS-1550011	Flat Washer	M3	4
1512	F001156	Phillips Pan Hd Mach Screw	M3X12	4
1515	F001216	Phillips Pan Hd Mach Screw	M8X6	2
1516	GHB1236-1516	Handle		1
1601	GHB1236-1601	Left bracket		1
1602	TS-1502021	Hex Socket Hd Cap Screw	M5x10	2
1603	GHB1236-1603	Spring cover		2
1604	GHB1236-1604	Left Collar		1
1605	TS-1503031	Hex Socket Hd Cap Screw	M6x12	8
1606	GHB1236-1606	Bracket Plate		2
1607	TS-1501031	Hex Socket Hd Cap Screw	M4x10	2
1608	GHB1236-1608	Right Collar		1
1609	GHB1236-1609	Right Bracket		1

13.15.1 Accessories – Exploded View

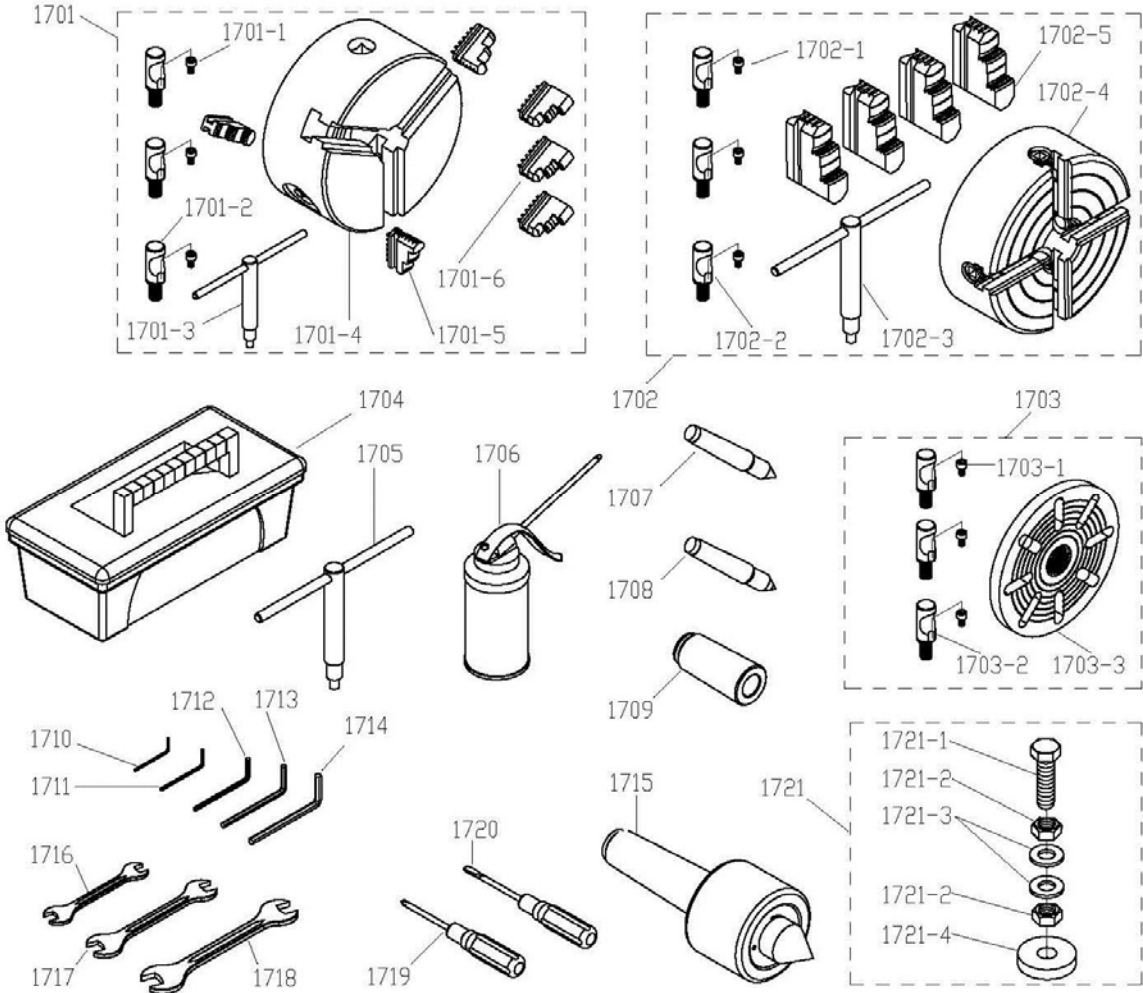

### 13.15.2 Accessories – Parts List

Index No.	Part No.	Description	Size	Qty
1701	GHB1236-1701	3-Jaw Chuck Assembly	160MM-D4	1
1701-1	TS-1503031	Hex Socket Hd Cap Screw	M6X12	3
1701-2	GHB1236-1701-2	Camlock Stud		3
1701-3	GHB1236-1701-3	3-Jaw Chuck Key		1
1701-4	GHB1236-1701-4	3-Jaw chuck Body		1
1701-5	GHB1236-1701-5	Internal Jaws 3PCS Set		1
1701-6	GHB1236-1701-6	Reverse Jaws 3PCS Set		1
1702	GHB1236-1702	4-Jaw Chuck Assembly	200MM-D4	1
1702-1	TS-1503031	Hex Socket Hd Cap Screw	M6X12	3
1702-2	GHB1236-1702-2	Camlock Stud		3
1702-3	GHB1236-1702-3	4-Jaw Chuck Key		1
1702-4	GHB1236-1702-4	4-Jaw Chuck Body		1
1702-5	GHB1236-1702-5	Jaws 4PCS Set		1
1703	GHB1236-1703	Face Plate Assembly	250MM	1
1703-1	TS-1503031	Hex Socket Hd Cap Screw	M6X12	3
1703-2	GHB1236-1703-2	Camlock Stud		3
1703-3	GHB1236-1703-3	Face Plate Body		1
1704	GHB1236-TBC	Tool Box Complete *		1
1705	GHB1236-1705	Key for Cam Locks *		1
1706	GHB1236-1706	Oil Gun *		1
1707	GHB1236-1707	Dead Center *	MT3	1
1708	GHB1236-1707	Dead Center *	MT3	1
1709	GHB1236-1709	Tapered Reducing Sleeve *	MT5-MT3	1
1710	JHL610-901	Hex Wrench *	2MM	1
1711	TS-152704	Hex Wrench *	3MM	1
1712	TS-152705	Hex Wrench *	4MM	1
1713	TS-152706	Hex Wrench *	5MM	1
1714	TS-152707	Hex Wrench *	6MM	1
1715	GHB1236-1715	Live Center *	MT3	1
1716	GH1340A-TBCP-16-04	Open End Wrench *	10-12MM	1
1717	JBOS5-105	Open End Wrench *	14-17MM	1
1718	GH1340A-TBCP-16-06	Open End Wrench *	17-19MM	1
1719	ZX-OP-15	Cross Point Screwdriver *	3"	1
1720	ZX-OP-14	Flat Blade Screwdriver *	3"	1
1721	GHB1236-1721	Sizing Block Assembly		6
1721-1	F008920	Hex Cap Bolt	M14x50	6
1721-2	TS-154009	Hex Nut	M14	12
1721-3	TS-155009	Flat Washer	M14	12
1721-4	GHB1236-1721-4	Washer, spcl		6

\* included in GHB1236-TBC, Tool Box

# 14.0 Wiring Diagram for GHB-1236

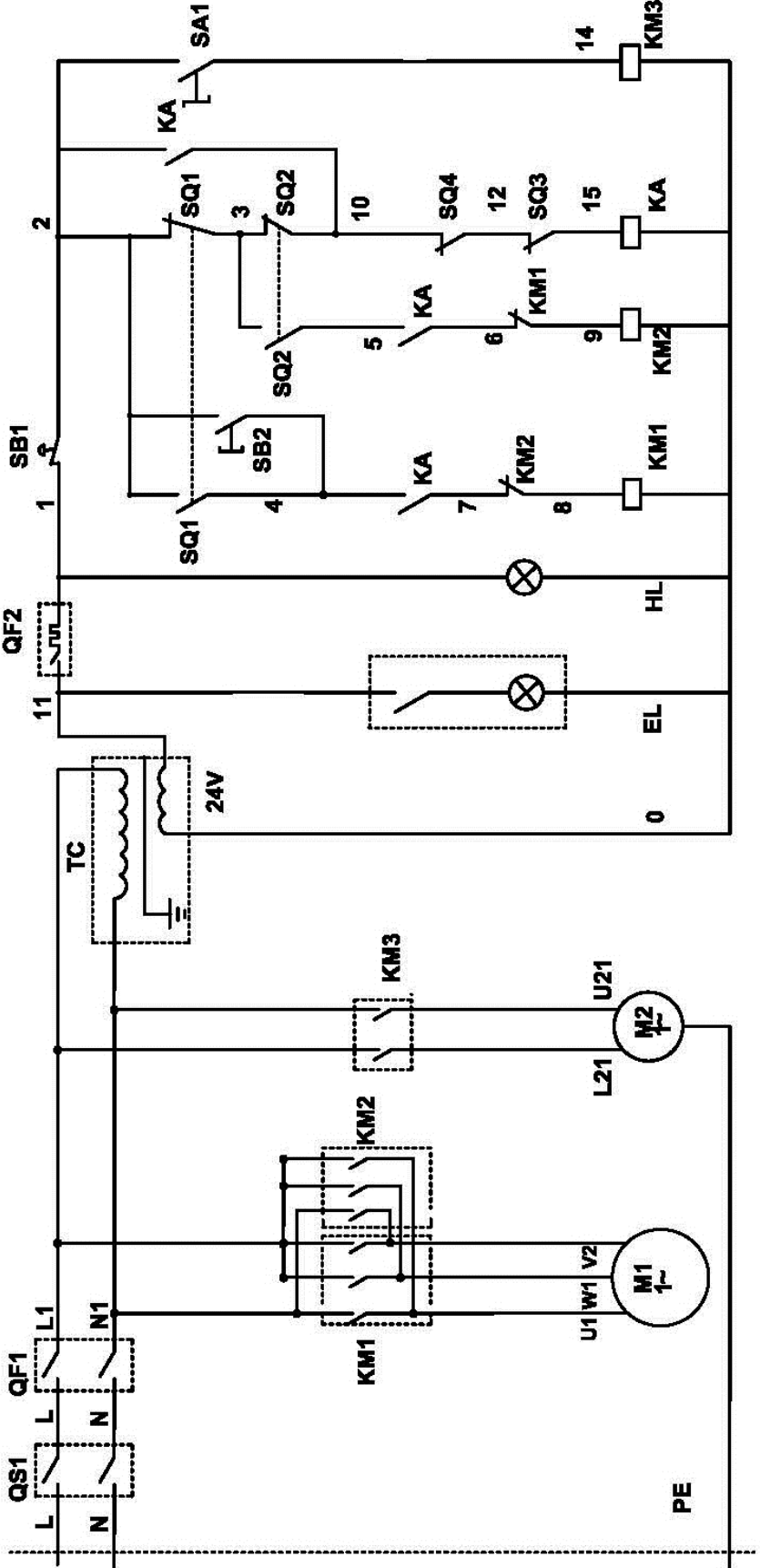

# 15.0 Warranty and service

JET warrants every product it sells against manufacturers' defects. If one of our tools needs service or repair, please contact Technical Service by calling 1-800-274-6846, 8AM to 5PM CST, Monday through Friday.

**Warranty Period**

The general warranty lasts for the time period specified in the literature included with your product or on the official JET branded website.

- JET products carry a limited warranty which varies in duration based upon the product. (See chart below)
- Accessories carry a limited warranty of one year from the date of receipt.
- Consumable items are defined as expendable parts or accessories expected to become inoperable within a reasonable amount of use and are covered by a 90 day limited warranty against manufacturer's defects.

**Who is Covered**

This warranty covers only the initial purchaser of the product from the date of delivery.

**What is Covered**

This warranty covers any defects in workmanship or materials subject to the limitations stated below. This warranty does not cover failures due directly or indirectly to misuse, abuse, negligence or accidents, normal wear-and-tear, improper repair, alterations or lack of maintenance. JET woodworking machinery is designed to be used with Wood. Use of these machines in the processing of metal, plastics, or other materials may void the warranty. The exceptions are acrylics and other natural items that are made specifically for wood turning.

**Warranty Limitations**

Woodworking products with a Five Year Warranty that are used for commercial or industrial purposes default to a Two Year Warranty. Please contact Technical Service at 1-800-274-6846 for further clarification.

**How to Get Technical Support**

Please contact Technical Service by calling 1-800-274-6846. **Please note that you will be asked to provide proof of initial purchase when calling.** If a product requires further inspection, the Technical Service representative will explain and assist with any additional action needed. JET has Authorized Service Centers located throughout the United States. For the name of an Authorized Service Center in your area call 1-800-274-6846 or use the Service Center Locator on the JET website.

**More Information**

JET is constantly adding new products. For complete, up-to-date product information, check with your local distributor or visit the JET website.

**How State Law Applies**

This warranty gives you specific legal rights, subject to applicable state law.

**Limitations on This Warranty**

JET LIMITS ALL IMPLIED WARRANTIES TO THE PERIOD OF THE LIMITED WARRANTY FOR EACH PRODUCT. EXCEPT AS STATED HEREIN, ANY IMPLIED WARRANTIES OF MERCHANTABILITY AND FITNESS FOR A PARTICULAR PURPOSE ARE EXCLUDED. SOME STATES DO NOT ALLOW LIMITATIONS ON HOW LONG AN IMPLIED WARRANTY LASTS, SO THE ABOVE LIMITATION MAY NOT APPLY TO YOU. JET SHALL IN NO EVENT BE LIABLE FOR DEATH, INJURIES TO PERSONS OR PROPERTY, OR FOR INCIDENTAL, CONTINGENT, SPECIAL, OR CONSEQUENTIAL DAMAGES ARISING FROM THE USE OF OUR PRODUCTS. SOME STATES DO NOT ALLOW THE EXCLUSION OR LIMITATION OF INCIDENTAL OR CONSEQUENTIAL DAMAGES, SO THE ABOVE LIMITATION OR EXCLUSION MAY NOT APPLY TO YOU.

JET sells through distributors only. The specifications listed in JET printed materials and on official JET website are given as general information and are not binding. JET reserves the right to effect at any time, without prior notice, those alterations to parts, fittings, and accessory equipment which they may deem necessary for any reason whatsoever. JET® branded products are not sold in Canada by JPW Industries, Inc.

**Product Listing with Warranty Period**

90 Days – Parts; Consumable items
1 Year – Motors; Machine Accessories
2 Year – Metalworking Machinery; Electric Hoists, Electric Hoist Accessories; Woodworking Machinery used for industrial or commercial purposes
5 Year – Woodworking Machinery
Limited Lifetime – JET Parallel clamps; VOLT Series Electric Hoists; Manual Hoists; Manual Hoist Accessories; Shop Tools; Warehouse & Dock products; Hand Tools; Air Tools

NOTE: JET is a division of JPW Industries, Inc. References in this document to JET also apply to JPW Industries, Inc., or any of its successors in interest to the JET brand.

This page intentionally left blank.



427 New Sanford Road  
LaVergne, Tennessee 37086  
Phone: 800-274-6848  
[www.jettools.com](http://www.jettools.com)