



Parts List for #578172 Grinder Stand

Assemble the stand using the drawing at right as reference.

Tools required for stand assembly:
8mm hex key ("Allen wrench")

1. Slide post (#2) into base (1). Secure by tightening the four socket head cap screws (9) against the post, and tighten nuts (8) against the base.
2. Slide water pot frame (5) over post (2). Secure with screw and nut (8/9).
3. Push platform (7) down over post (2) and secure with screws and nuts (8/9).
4. Place water pot (6) into frame (5). Adjust frame to desired height on post.
5. Mount grinder to platform using fasteners (10-13).

Operation: Fill water pot (6) with water. Dip workpiece into the water to cool it after grinding. Do not apply water directly to the grinding wheels.

Index	Part No.	Description	Qty.
1	IBGS-01	Base	1
2	IBGS-02	Post	1
5	IBGS-05	Water Pot Frame	1
6	IBGS-06	Water Pot	1
7	IBGS-07	Platform	1
8	TS-1540071	Hex Nut, M10	6
9	TS-1505041	Soc Hd Cap Screw, M10x30	6
10	TS-1490071	Hex Cap Screw, M8x40	4
11	TS-1550061	Flat Washer, M8	8
12	TS-2361081	Lock Washer, M8	4
13	TS-1540061	Hex Nut, M8	4

Specifications

Stock number578172
 Assembled size (in.)..... 21-1/2"L x 10-3/4"W x 33"H
 Packing size (in.).....32-1/4"L x 19"W x 10"H
 Net weight (lbs)69
 Shipping weight (lbs).....74

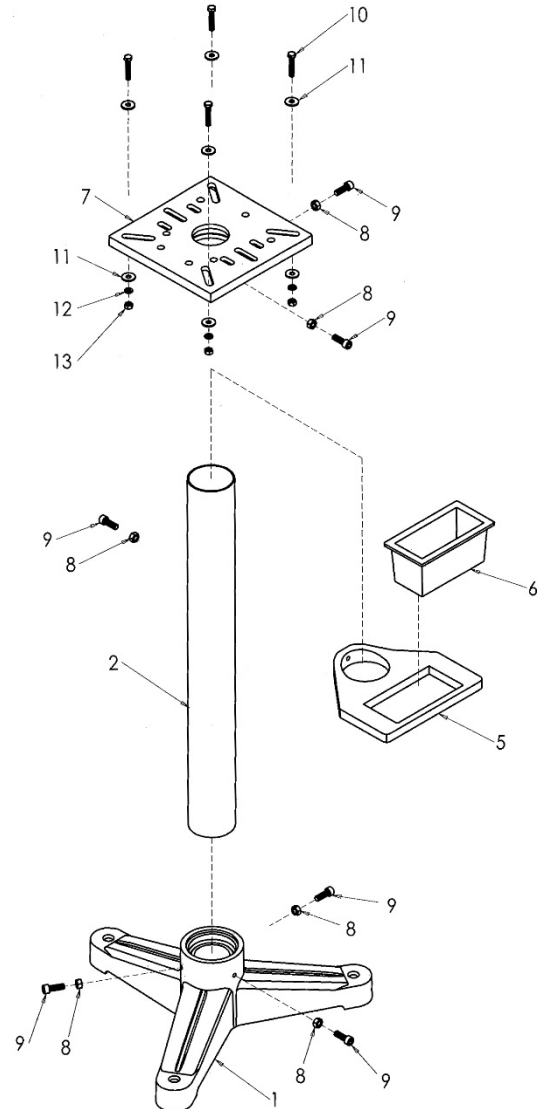

Specifications were current at time of publication, but because of our policy of continuous improvement, JET reserves the right to change specifications at any time and without prior notice, without incurring obligations.

JET

427 New Sanford Road
 LaVergne, Tennessee 37086
 Ph.: 800-274-6848
 www.jettools.com

Part No. M-578172
 Revision C 04/2017

Copyright © 2017 JET, a Division of JPW Industries, Inc.