

Sonar-Spot™ Wheel Balancer

Installation and Operation Manual

Manual P/N 5900407 — Manual Revision A — September 2024

Model:

- LS45DS



Designed and engineered in Southern California, USA. Made in China

 **DANGER**

Read the entire contents of this manual **before** using this product. Failure to follow the instructions and safety precautions in this manual can result in serious injury or death. Make sure all other operators also read this manual. Keep the manual near the product for future reference.
By proceeding with setup and operation, you agree that you fully understand the contents of this manual and assume full responsibility for product use.

Manual. LS45DS Laser-Spot™ Wheel Balancer, *Installation and Operation Manual*, Manual P/N 5900407, Manual Revision A, released September 2024.

Copyright. Copyright © 2024 by BendPak Inc. All rights reserved. You may make copies of this document if you agree that: you will give full attribution to BendPak Inc., you will not make changes to the content, you do not gain any rights to this content, and you will not use the copies for commercial purposes.

Trademarks. BendPak, the BendPak logo, Ranger, and the Ranger logo are registered trademarks of BendPak Inc. All other company, product, and service names are used for identification only. All trademarks and registered trademarks mentioned in this manual are the property of their respective owners.

Limitations. Every effort has been made to have complete and accurate instructions in this manual. However, product updates, revisions, and/or changes may have occurred since this manual was published. BendPak Ranger reserves the right to change any information in this manual without incurring any obligation for equipment previously or subsequently sold. BendPak Ranger is not responsible for typographical errors in this manual. Feel free to contact us at any time to receive the latest information about any product: rangerproducts.com.



SCAN FOR
DIGITAL PDF

Warranty. The BendPak Ranger warranty is more than a commitment to you: it is also a commitment to the value of your new product. For full warranty details, contact your nearest BendPak Ranger dealer or visit bendpak.com/support/warranty. Go to bendpak.com/support/register-your-product/ and fill out the online form to register your product (be sure to click **Submit**).

Safety. Your new product was designed and manufactured with safety in mind. Your safety also depends on proper training and thoughtful operation. Do not set up, operate, maintain, or repair the unit without reading and understanding this manual and the labels on it; **do not use this product unless you can do so safely!**

Owner Responsibility. In order to maintain your product properly and to ensure operator safety, it is the responsibility of the product owner **to read and follow these instructions**:

- Follow all setup, operation, and maintenance instructions.
- Make sure product setup conforms to all applicable local, state, and federal codes, rules, and regulations, such as state and federal OSHA regulations and electrical codes.
- Read and follow all safety instructions. Keep them readily available for operators.
- Make sure all operators are properly trained, know how to safely operate the unit, and are properly supervised.
- Do not operate the product until you are certain that all parts are in place and operating correctly.
- Carefully inspect the product on a regular basis and perform all maintenance as required.
- Service and maintain the unit only with approved replacement parts.
- Keep the manual with the product and make sure all labels are clean and visible.
- **Only use this product if it can be used safely!**

Unit Information. Enter the Model Number, Serial Number, and the Date of Manufacture from the label on your unit. This information is required for part or warranty issues.

Model: _____

Serial: _____

Date of Manufacture: _____

Table of Contents

Introduction	3	Operation	22
Shipping Information	4	Maintenance	49
Safety Considerations	4	Troubleshooting	50
Components	6	Wiring Diagram	55
FAQ	8	Labels	56
Specifications	9	Parts	58
Installation Checklist	10	Maintenance Log	74
Installation	11		

Introduction

This manual describes the Installation and Operating instructions for the Ranger LS45DS Wheel Balancer. The LS45DS is a computer-controlled Wheel Balancer providing fast, accurate Wheel balancing for a wide variety of Wheels.

The LS45DS includes our exclusive Laser-Spot™ technology for precise weight placement and Sonar-Spot for accurate Wheel Width measurements.

More information about BendPak Ranger products is available at rangerproducts.com.

This manual is mandatory reading for all users of the LS45DS, including anyone who installs, operates, maintains, or repairs it.

 DANGER Be very careful when setting up, operating, maintaining, or repairing this equipment; failure to do so could result in property damage, product damage, injury, or (in very rare cases) death. Make sure only authorized personnel operate this equipment. An authorized technician must perform all repairs. Do not make modifications to the unit; this voids the warranty and increases the chances of injury or property damage. Make sure to read and follow the instructions on the labels on the unit.

Keep this manual on or near the equipment so that anyone who uses or services it can read it.

Technical support and service for your Wheel Balancer is available from your distributor or by calling **BendPak Ranger at (805) 933-9970**. You may also call regarding parts replacement (please have the serial number and model number of your unit available).

Shipping Information

Your equipment was carefully checked before shipping. Nevertheless, you should thoroughly inspect the shipment **before** you sign to acknowledge that you received it.

When you sign the bill of lading, it tells the carrier that the items on the invoice were received in good condition. **Do not sign the bill of lading until after you have inspected the shipment.** If any of the items listed on the bill of lading are missing or damaged, do not accept the shipment until the carrier makes a notation on the bill of lading that lists the missing or damaged goods.

If you discover missing or damaged goods **after** you receive the shipment and have signed the bill of lading, notify the carrier at once and request the carrier to make an inspection. If the carrier will not make an inspection, prepare a signed statement to the effect that you have notified the carrier (on a specific date), and that the carrier has failed to comply with your request.

It is difficult to collect for loss or damage after you have given the carrier a signed bill of lading. If this happens to you, file a claim with the carrier promptly. Support your claim with copies of the bill of lading, freight bill, invoice, and photographs, if available. Our willingness to assist in helping you process your claim does not make us responsible for collection of claims or replacement of lost or damaged materials.

Safety Considerations

Read this manual carefully before using your new product. Do not set up or operate the product until you are familiar with all operating instructions and warnings. Do not allow anyone else to operate the product until they are also familiar with all operating instructions and warnings. Keep this manual on or near the product for future reference.

 **WARNING** **California Proposition 65.** This product can expose you to chemicals including styrene and vinyl chloride which are on the list of over 900 chemicals identified by the State of California to cause cancer, birth defects or reproductive harm. Always use this product in accordance with BendPak's instructions. For more information, visit www.p65warnings.ca.gov.

Safety Information

Please note the following:

-  **WARNING** Do **not** look directly into the laser. Doing so may damage your eyes.
- The product is a Wheel Balancer. **Use it only for its intended purpose.**
 - The product should only be operated by authorized personnel. Keep children and untrained personnel away from the product.
 - When using the product, wear appropriate work clothes (*NO loose clothing*) and ANSI-approved safety goggles (or similar). Keep hair, jewelry, and clothing away from the Balancer.
 - When a Wheel is spinning, keep hands and arms away.
 - Do not use the product while tired or under the influence of drugs, alcohol, or medication.
 - Do not use the product in the presence of cigarette smoke, dust, flammable liquids, or gases. Use the product indoors in a well-ventilated and well lighted area.

-
- Do not make any modifications to the product; this voids the warranty and increases the chances of injury or property damage.
 - Make sure all operators read and understand the *Installation and Operation Manual*. Keep this manual near the device at all times.
 - Make a visual inspection of the product before using it each time. Do not use the product if you find any missing or damaged parts. Instead, take the unit out of service, then contact an authorized repair facility, your distributor, or **Ranger Products at (805) 933-9970**.
 - BendPak Ranger recommends making a **thorough** inspection of the product once a month. Replace any damaged or severely worn parts, decals, or warning labels.

Symbols

Following are the symbols that may be used in this manual:



DANGER

Calls attention to a hazard that **will** result in death or injury.



WARNING

Calls attention to a hazard or unsafe practice that **could** result in death or injury.



CAUTION

Calls attention to a hazard or unsafe practice that could result in personal injury, product damage, or property damage.

NOTICE

Calls attention to a situation that, if not avoided, could result in product or property damage.



Tip

Calls attention to information that can help you use your unit better.

Liability Information

BendPak Ranger assumes **no** liability for damages resulting from:

- Use of the equipment for purposes other than those described in this manual.
- Modifications to the equipment without prior, written permission from BendPak Ranger.
- Modifying, disabling, overriding, or removing safety features.
- Damage to the equipment from external influences.
- Incorrect operation of the equipment.

Components

Wheel Balancer components include:

- **Display Panel.** Shows balance and test mode data when using the Balancer.
- **Cover.** Protects the operator from the Wheel while it is in motion.
- **Inner Arm / Distance Ruler.** Used to determine the Distance between the Balancer and the inner edge of the Wheel being balanced.
- **Sonar Sensor.** Detects the Width of the Wheel being balanced.
- **Control Panel.** Used to control the Balancer.
- **Power Switch.** Turns the Balancer on and off.
- **Storage Trays.** Storage for Clip-On Weights and other items you want to have handy.
- **Adhesive Weight Dispensers.** Dispenses your Adhesive Weights.
- **Storage Rack.** Holds items you want to have handy.
- **Collet Hangers.** Hold Mounting Collets when not in use.

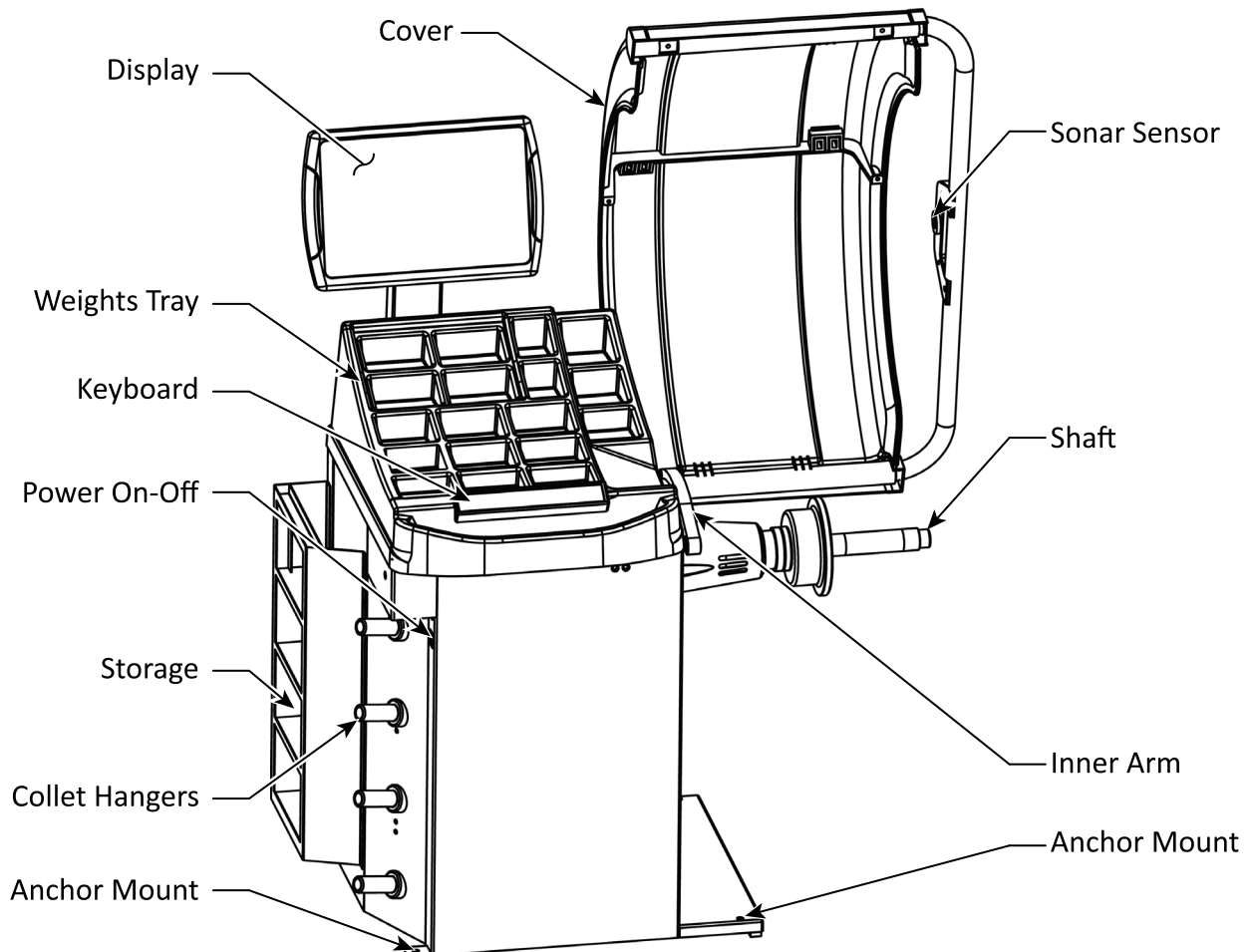

Balancer accessories include:

- **Quick-Release Hub Nut.** Holds the Wheel on the Balancer once the Wheel is mounted.
- **Hex Key Wrenches.** Used during installation. Hex key wrenches are sometimes called Allen® wrenches.
- **Anchor Bolts.** Anchor the Balancer to the floor at the desired location. Anchoring the Balancer is optional, but strongly recommended.
- **Hammer Wheel Weight Tool.** Used to install and remove Clip-On Weights.
- **Adhesive Weight Removal Tool.** Used to remove Adhesive Weights.
- **Mounting Spring.** Secures the Wheel when using Rear- and Dual-Collet Mounting.
- **Mounting Collet assortment.** Supports a wide range of Wheel sizes. The Collets center and support the Wheel on the Balancer Shaft.
- **Lug-Centric Pressure Plate.** Used to center the wheel on the shaft using the Wheel's Lug Bolt openings.
- **Calipers.** Used to measure the Width of a Wheel for manual input. Done automatically in most cases, so you may not need to use the Calipers too often.
- **Spacer Ring.** Attaches to the Shaft Flange for larger Wheels only.

All of the Balancer accessories are shown and identified in **Parts** (the Balancer accessories are shown on one of the pages towards the end of the Parts section).

Other terms to understand include:

- **Wheel.** A circular metal piece that attaches to an axle and rotates. The Tire is a separate item that installs around a Wheel.
- **Tire.** A specially designed and sized circular rubber structure that surrounds and attaches to a Wheel; more specifically, to the Rim, which is the part of the Wheel that directly retains the Tire. Most Tires are pneumatically inflated (filled with a gas, such as compressed air, hydrogen, helium, or nitrogen) and made from rubber (synthetic or natural).
- **Rim.** The part of a Wheel that directly attaches to a Tire, almost always the outer portion of the Wheel. Because modern Wheels are frequently created from a single piece of metal, “Wheel” and “Rim” are sometimes used interchangeably.
- **Hub.** The part of a Wheel that is not the Rim, the central portion of the Wheel.
- **Imbalance.** An unbalanced weight distribution in a Wheel; it can cause uneven rotation (which results in Wheel wobble, uneven Tire wear, and Vehicle vibration). **To correct an imbalance, a weight must be applied opposite the imbalance.**
- **Planes.** When a Wheel is figuratively divided down the middle into two sections, it creates two planes; called Inner and Outer (see **About Planes** for more information). Balancing is more effective when planes are analyzed for imbalance separately (and addressed separately), called Dynamic Balancing. Inner and Outer planes are **not** the same as the three specific locations on the Wheel where Weight can be added, named Inner Plane, Center Plane, and Outer Plane.
- **Clip-On Weights.** Metal weights that are held in place on the Wheel by gripping the Inner and/or Outer Edges of the rims. Older Clip-On Weights *made of lead* should **not** be used as they are a hazard to the environment; they are also illegal to use in many countries and states in the U.S.
- **Adhesive Weights.** Weights that are flat and held in place on the Wheel with double-stick adhesive; and placed on the Inner, Outer, or Center Plane. Adhesive Weights come in both black and gray, making them less noticeable visually on the Vehicle's Wheels/Rims.
- **Placement Indicators.** Light up when the best weight location is reached.
- **Balancing modes.** The Balancer supports Dynamic Balancing, Static Balancing, Aluminum Alloy Balancing, and Hidden Balancing Modes.

-
- **Dynamic Balancing.** Balancing a steel Wheel where each of the two planes are analyzed separately. If there is an imbalance, the two planes are brought back into balance separately. Dynamic Balancing is newer technology than Static Balancing and generally provides a better balance.
 - **Static Balancing.** Balancing a Wheel as a whole; that is, on a single plane only. This is an older method of balancing and is generally not as effective as Dynamic Balancing. Static Balancing is required for motorcycle Wheels and older Wheels that are 4 inches wide or less; also used if only Adhesive Weights can be attached on the Center Plane (hidden) of the Wheel as often customer-requested on vintage mag wheels.
 - **Aluminum Alloy Balancing.** Balancing Wheels made of aluminum alloy. The Weights are placed differently on these Wheels, so you need to know where you want to put the Weights and select the appropriate ALU Mode. ALU Modes generally use Adhesive Weights, which are less visible than Clip-On Weights.
 - **HID (Hidden) Balancing.** Balancing a Wheel where the Outer Plane Weights are placed behind selected spokes, so they are hidden, as much as possible.
 - **Optimize Function.** When a Wheel has significant imbalance (30 grams / 1 ounce or more), you can use the optional Optimize Function to lessen the imbalance.

Frequently Asked Questions

Question: What does a Wheel Balancer do?

Answer: Wheel Balancers correct rotational imbalances that are often present in wheel and tire assemblies. If you drive a Vehicle with imbalanced Wheels, the Vehicle could experience noise, vibrations, wobbling, reduced or uneven Tire tread wear, and some components may wear out quickly.

Q: What is the difference between Wheel Balancing and Wheel Alignment?

A: When you *balance* a Wheel, you remedy a weight distribution issue that can cause Wheel wobble, uneven Tire wear, and Vehicle vibration. The solution adds Weights on the Wheel in appropriate locations to counteract the rotational imbalance.

Q: Where can I place my Wheel Balancer?

A: A flat Concrete floor with room around it to freely allow operating a wheel balancer. This means a less traveled shop area, where bystanders will not be present, vehicles will not be close, and shop deliveries can carry on without conflict.

Q: Why are there two types of Weights?

A: Clip-On Weights are engineered to mechanically grip the outer and/or inner edges of some wheels. Adhesive Weights are designed to have more placement freedom to correct an imbalance. Some Vehicle owners with expensive Tires prefer Adhesive Weights because they are less visible, do not leave removal marks, and are also available in either black or gray colors.

Q: Why isn't there a plug on the end of the Power Cord?

A: 220 VAC plugs vary by region, so you need to use one that is appropriate for the power outlet where you will be using your Wheel Balancer. All electrical work must be accomplished by a licensed Electrician in accordance with national and local electrical codes.

Specifications

Model	LS45DS
Motor	220 VAC, 3A, 50/60 Hz, 1 Ph, 0.55kW
Working Temperature	27°F to 82°F (-5°C to 50°C)
Balancing Modes	1 dynamic / 1 static / 3 aluminum alloy / 1 hidden
Maximum Tire Diameter	31.5" (800 mm)
Maximum Wheel Weight	145 lbs. (65 kg)
Max. Wheel Diameter	12" to 24" (305 mm to 610 mm) *
Wheel Width Capacity	4" to 20" (102 to 508 mm)
Balancing Increments	.01 ounce (0.25 grams)
Accuracy	± .035 oz (1 gram)
Resolution	.25 oz. (5 grams)
Height, Guard Up	66" (1,676 mm)
Height, Guard Down	53" (1,346 mm)
Width	54" (1,371 mm)
Depth, Cover Up	39" (990 mm)
Depth, Cover Down	40" (1,016 mm)
Power Cord Length	63" (1,600 mm)
Operating Temperature	41°F – 122°F (5°C – 50°C)

***IMPORTANT NOTE! To Balance a 43" (1100 mm) Tire the Outer Arm and Outer Arm Mount Bar must be removed. All data for this size tire must be entered manually.**

Installation Checklist

Following are the steps required to install the LS45DS Wheel Balancer. Perform them in the order shown.

- 1. Review the installation Safety Rules.
- 2. Plan for Electrical Work.
- 3. Make sure you have the necessary Tools.
- 4. Select the Installation Site.
- 5. Make sure there is adequate Clearance on all Sides.
- 6. Unpack the Components.
- 7. Identify the Components on the Back of the Unit.
- 8. Install the Display Panel.
- 9. Install the Mount Box.
- 10. Install the Cover.
- 11. Install the Outer Arm.
- 12. Install the Shaft.
- 13. Anchor the Unit.
- 14. Connect to a Power Source. **Requires a licensed Electrician.**
- 15. Test the Balancer.
- 16. Review the Final Checklist.

Installation

This section describes how to install your Wheel Balancer.

Installation Safety Rules

Always pay attention during installation. Use appropriate tools and equipment. Stay clear of moving parts. Keep hands and fingers away from pinch points.

Use caution when unpacking the Balancer from its shipping container and setting it up. The Balancer is heavy, and the weight is not evenly distributed; dropping or knocking over the unit may cause equipment damage or personal injury.

⚠ WARNING You must always wear appropriate protective clothing during setup: leather gloves, non-skid steel-toed work boots, ANSI-approved eye protection, and an industrial back belt. Although rare, an accident could cause significant injuries. The Balancer includes a laser spotter: **Do not look directly into the laser.**

Only allow experienced, trained technicians to install the Balancer. All electrical work **must** be done by a licensed Electrician.

⚠ CAUTION Certain parts of installing the Balancer are difficult for just one person. BendPak Ranger strongly recommends having two or more persons working together to install the Balancer.

If you have to use an extension cord, make sure its current rating is equal to or greater than that of the equipment being used. Make sure the extension cord cannot be stepped on, run over, or pulled out. Extension cords are also a tripping hazard, so they must be secured.

Plan for Electrical Work

The Balancer is not delivered with a Plug on the end of the Power Cord; it is the owner's responsibility to supply the Plug and have an Electrician attach it to the Power Cord.

Refer to **Wiring Diagram** for wiring information.

⚠ WARNING All electrical work, such as attaching the Plug to the Power Cord, **must be performed by a licensed Electrician** in accordance with all applicable national and local electrical codes.

Tools

You may need some or all of the following tools:

- Hex key wrench set (six hex keys are delivered with the unit: 3, 4, 5, 6, 8, and 12 mm in the Mount Bar box)
- SAE and Metric wrench sets
- Adjustable wrench
- Scissors, utility knife, or another cutting tool
- Hammer

Find a Location

Keep in mind the following when deciding on a location:

- **Power source.** The Balancer needs to be near an appropriate 220 VAC power source.
- **Floor.** The Balancer is best used on a flat, concrete floor. If the floor is unstable or not flat, the Balancer will not function correctly and will create faulty balance results.
- **Accessibility.** You need working space (away from customers, parts deliveries, and vehicles) to move the Wheels you are going to balance to-and-from the Balancer. And a suitable amount of room surrounding the balancer to operate.
- **Danger.** When a Wheel is spinning on the Balancer, keep people safely away. Do not set up the Balancer in a well-travelled area or near vehicles in for repair.
- **No water.** The Balancer has electronic components. If the Balancer becomes wet while turned on, those electronic components will most likely short circuit and have to be replaced.

⚠ WARNING Do not use the Balancer if it is setting in water. You may possibly short circuit the electronic components in the Balancer and may electrocute yourself.

Clearances

For safety purposes and to allow space to work with Wheels, a reasonable amount of room around the Balancer is needed. Remember to allow clearance to place rims, tires, and work on cars in bays.

*Provide sufficient clearance **above** the Balancer for the Cover to move freely.*

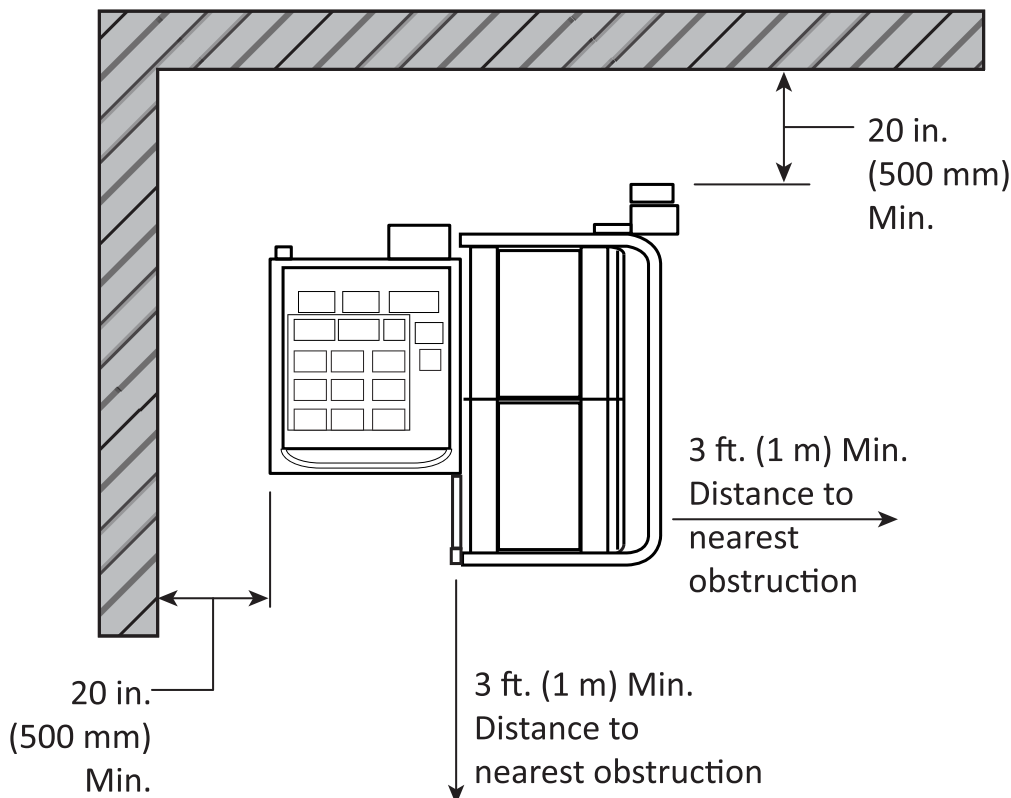

Unpacking

Use caution when unpacking the Balancer from its shipping container. Take care not to damage the unit, misplace any of the components, or become injured.

⚠ CAUTION Always use an appropriate lifting device, such as a forklift, pallet jack or hoist, to move the Balancer while it is on its pallet. Make sure only personnel who are experienced with material handling procedures are allowed to move the Balancer. The Balancer is heavy, and the weight is not evenly distributed; dropping or knocking over the unit may cause equipment damage or personal injury. Never lift the Balancer by its Shaft or Shaft Housing. The Balancer will be damaged.

We recommend you unpack the Balancer in the area where you are going to set it up.

To unpack the Balancer:

1. Remove the carton by flipping down the metal tabs at the bottom and pulling off the top.
2. Remove the shipping bolts that are securing the Balancer to the Pallet.
3. Remove the straps and plastic wrap that protected the Balancer components during shipment.
4. *Lean the Balancer over and reach underneath it to **pull out the Accessory Box**.*
5. Move the Balancer off the pallet, then move it to the desired location. Use a hoist, forklift, or other device that will safely and securely move the Balancer.

IMPORTANT! Do not lift the Balancer by its Shaft or Shaft Housing; doing so will damage the Balancer!

⚠ CAUTION Ranger recommends having at least two people move the Balancer; it is heavy. If it is dropped or falls, it could cause injury and/or the Balancer could be damaged.

Install the Cover Mounting Bracket Assembly

1. Retrieve the following from the parts box:
 - Four M4 x 8 mm SHCS
 - Four M8 x 20 mm SHCS
 - Four M8 Flat Washers
2. Secure the Cover Mounting Bracket the back panel of the Cabinet as shown below.

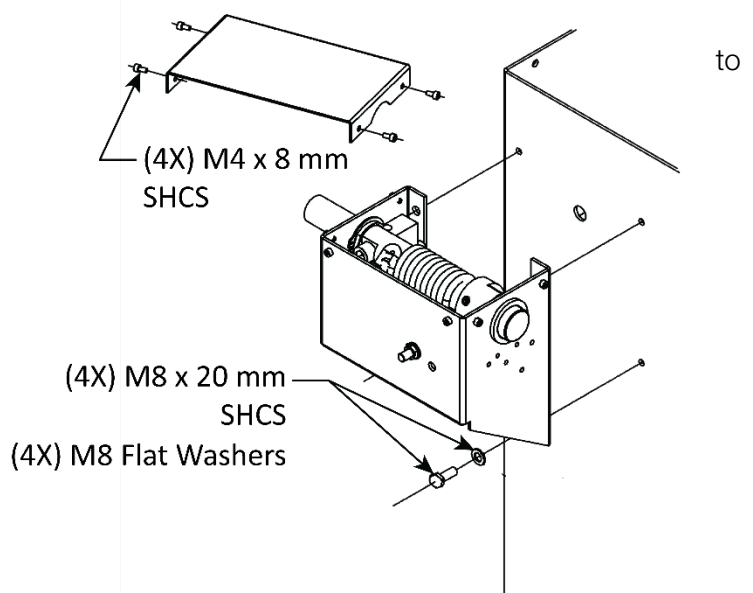

Install the Cover on the Bracket

1. Retrieve the following:
 - a. 2x Cover (half)
 - b. Cover Bracket
 - c. 10 mm Socket Cap Hex Screw
 - d. 10mm Flat Washer
 - e. 2x M2 x 12 mm Pan Head Screw

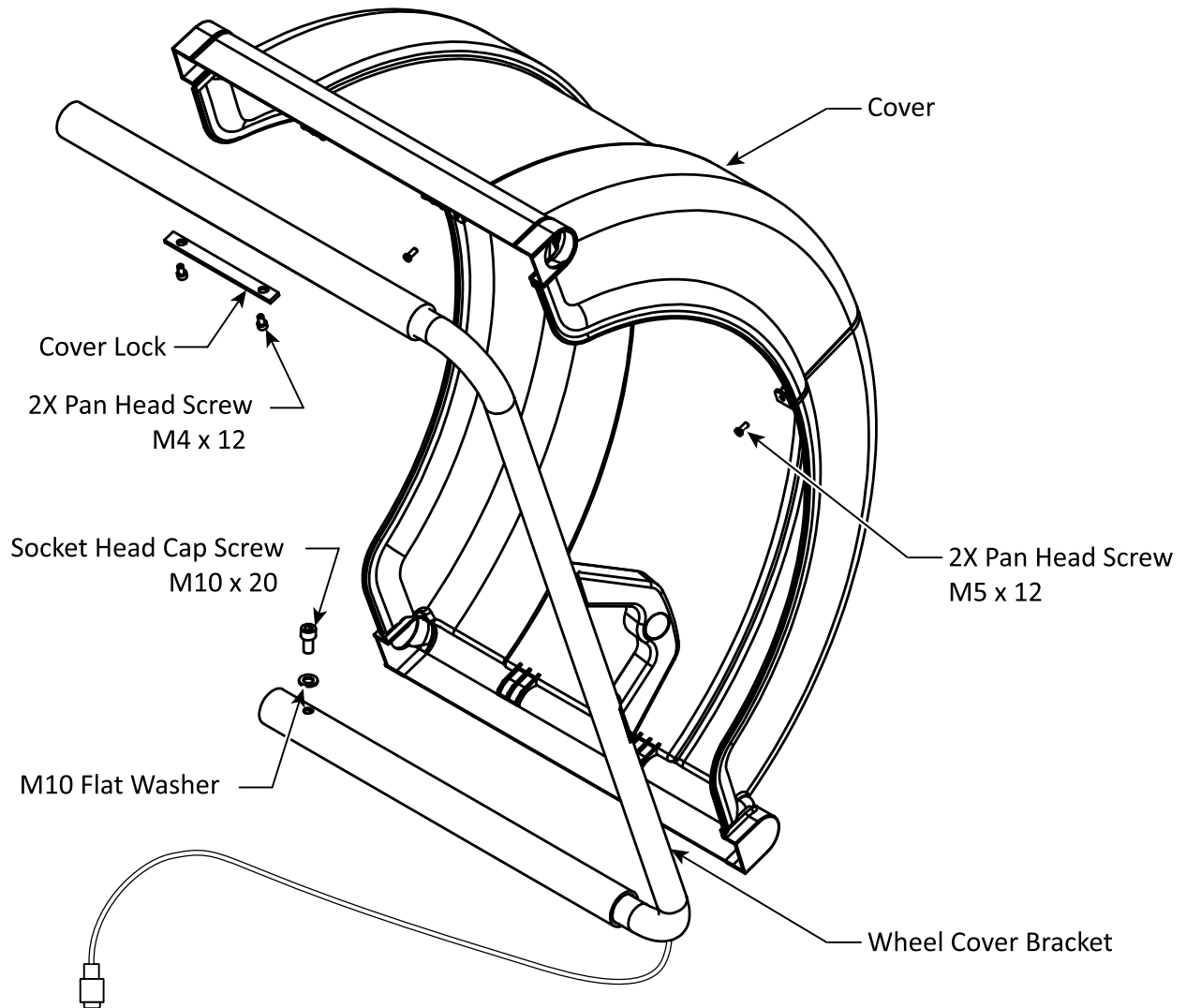

2. Remove the two M4 x 12 screws securing the Cover Lock to the Bracket.
3. Slide the Bracket into the Cover

- Secure the Cover to the Bracket using the Cover Lock and two M4 x 12 Screws.
- Secure the Sonar Wiring to the Wiring Clips on the Bracket and Cover.
- Secure the Bracket and Cover onto the Shaft Exiting the Mounting Bracket assembly on the rear of the Balancer Cabinet Using the M10 x 20 SHCS.

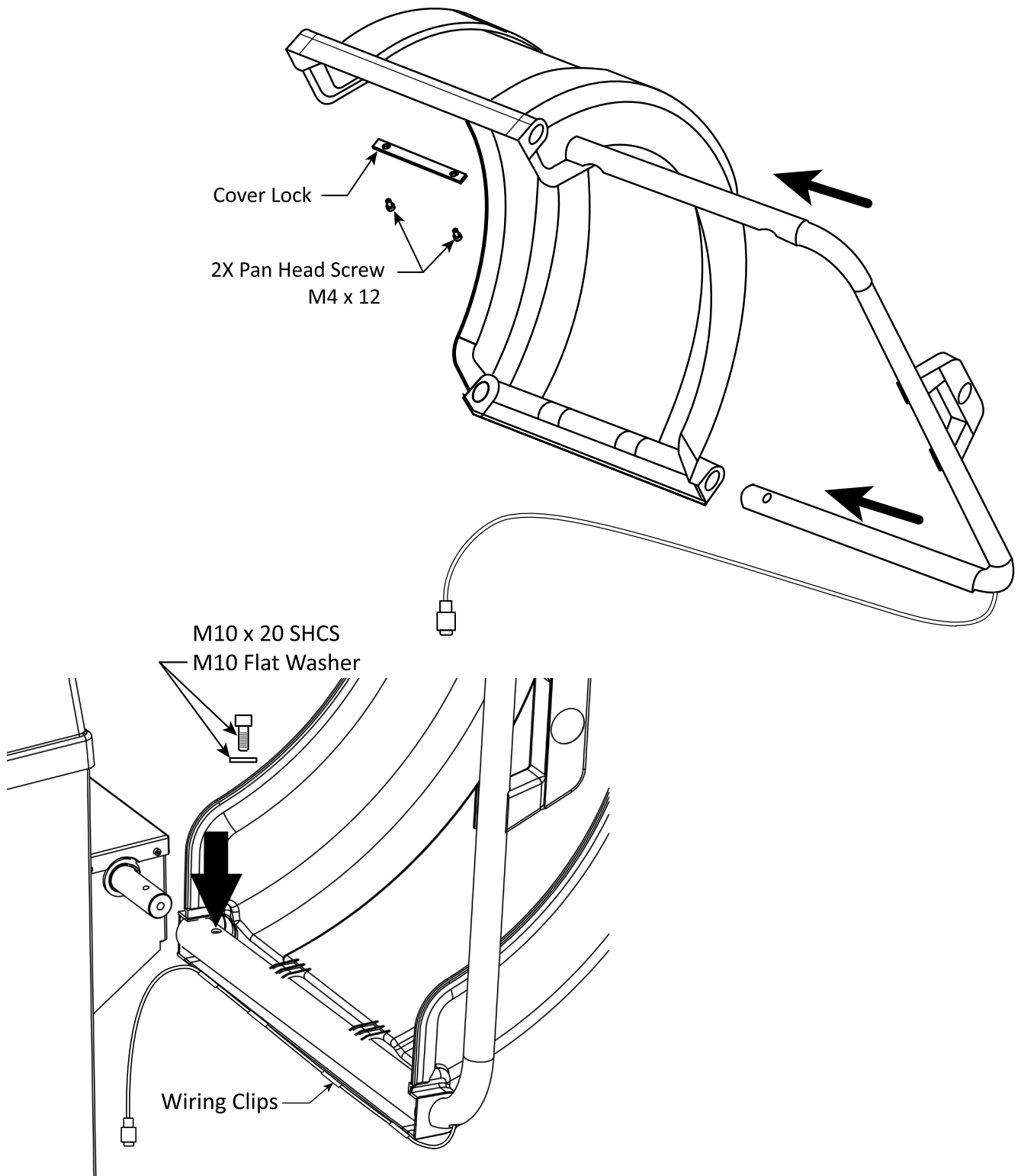

Installing the Display Panel

The Display Panel shows information about what is happening during the balancing of a Wheel.

To install the Display Panel:

7. Locate the Display Panel and the Display Panel Support.
 - The Display Panel Base Plate (located on the bottom of the Display Panel Support, connects to the back of the Balancer using four hex bolts, four split lock washers, and four standard washers; these fasteners are delivered already threaded into the back of the Balancer.
 - The Display Panel connects to the Display Panel Support using four hex bolts that are threaded into the back of the Display Panel.
8. Remove the four 8 mm hex bolts, four split lock washers, and four flat washers on the back of the Balancer.
9. Put the Display Panel Base Plate into position, then install the four hex bolts, four split lock washers, and four standard washers to secure it; tighten securely, but do not overtighten.
10. Remove the four 4 mm Pan Head Phillips Screws from the center back of the Display Panel.
11. Put the Display Panel into place against the Display Panel Support, then install the four hex bolts to secure it; tighten securely, but do not overtighten.

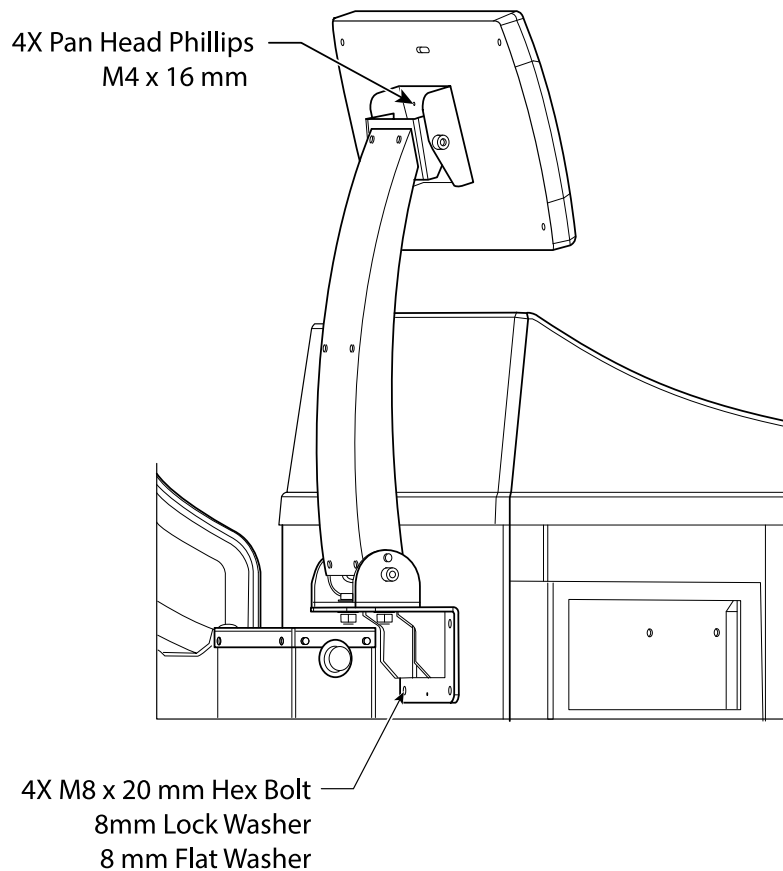

Connections on the Back of the Balancer

Make the electrical connections on the back panel.

- **Display Cable and Connector.** Connects to the back of the Balancer via the Display Panel Base Plate Five-Pin Connector refer to the figure below.
- **Cover Mounting Bracket Cable and Connector.** Connects to the back of the Balancer *Two-Pin Connector* refer to the figure below.
- **Sonar Cable.** Connects the Sonar Sensor to the back Plate of the Balancer. *Four-Pin Connector* refer to the figure below.
- **Electrical Power Cable.** A licensed Electrician is to connect an appropriate plug in accordance with national and local electrical codes.
- **Case Ground Terminal.** Only for use if the balancer is used in an area with high electrical interference (EMF). The electrical ground provided through the Power Cord is sufficient in most cases.

The figure below details the connections on the back of the Balancer.

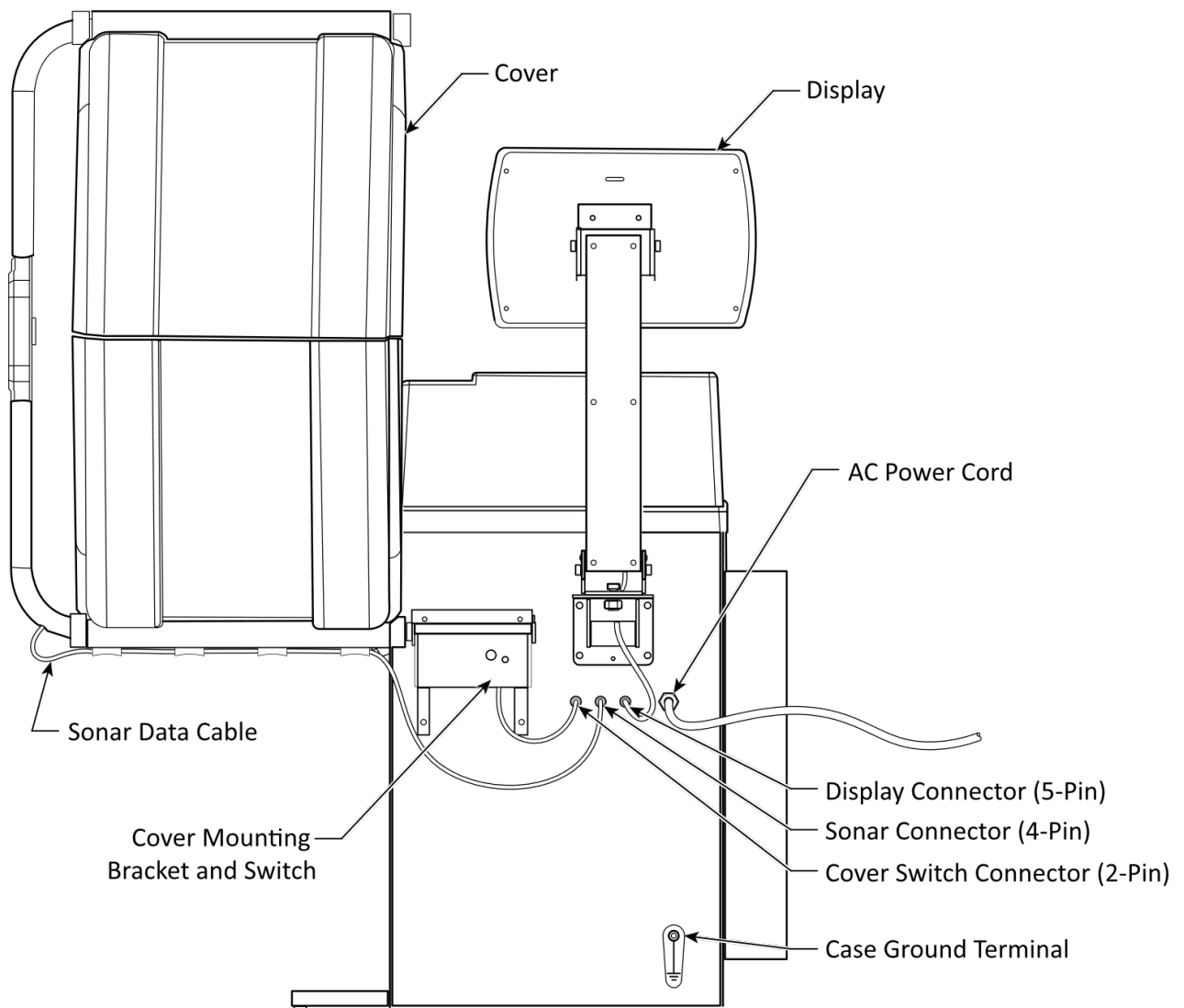

Not to scale. Components removed for clarity. The connectors are keyed and must be rotated until they snap into place. Then rotate the connector collar to lock.

Installing the Shaft

The Shaft supports the Wheels you are balancing.



Tip Consider having two assistants to install the Shaft: one to hold the Shaft Assembly in place while the second person screws in the Mounting Bolt. Also, consider having shop towels nearby as the Shaft is shipped with a heavy protective grease coating.

To install the Shaft:

1. Locate the Threaded Shaft Assembly and the Mounting Bolt (M14 x 280 mm) from the parts supplied with the Balancer.
2. Clean the Shaft Assembly by removing the shipping grease and any dirt that has accumulated with a clean shop towel.
3. Find the Alignment Marks (Witness Marks). This is a “0” punched into the Threaded Shaft and the Main Shaft. Align these marks when assembling the Shaft to the Housing.
4. Put the Shaft Assembly into place next to the Main Shaft and hold it so that the alignment (Witness) marks are in line.

Note: Mating the Threaded Shaft to the Shaft Housing is a critical part of the assembly process. Alignment or “Witness” marks are punched into the components to ensure accurate balance readings by minimizing shaft runout.

5. Put the Mounting Bolt into the end of the Threaded Shaft and *begin* tightening it.
6. *Before fully tightening* the Mounting Bolt, make sure the Alignment Marks line up (see figure below).

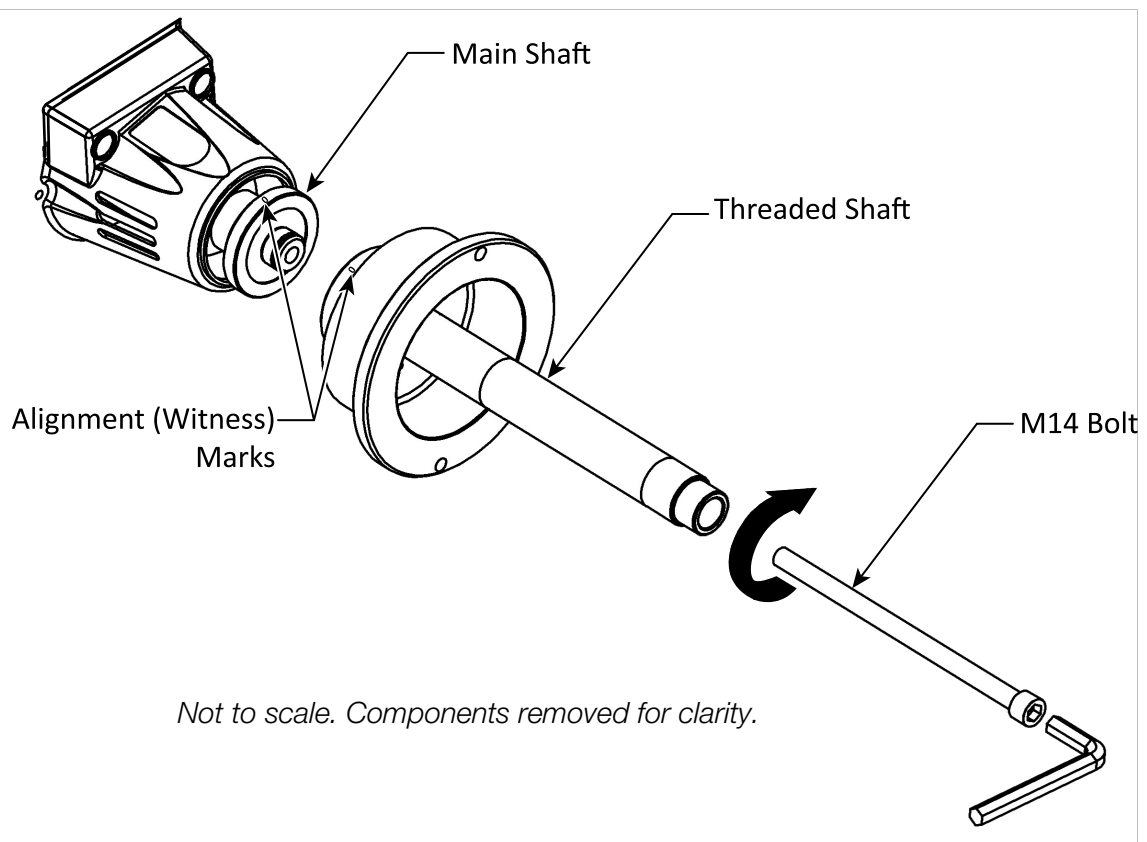

7. Tighten the Mounting Bolt into place.

Anchoring the Balancer

The Balancer provides three openings for Anchor Bolts, which hold the Balancer in place while in operation.

Important: You are **required** to bolt your Balancer into place, as movement during a Wheel Balance will result in inaccurate readings.

To anchor the Balancer:

1. Move the Balancer to the desired location.
Remember that you need to allow working space around the Balancer. Refer to [Finding a Location](#) for additional information.
2. Using the holes in the Balancer Base as guides, drill the holes for the M10 x 59 mm Anchor Bolts.

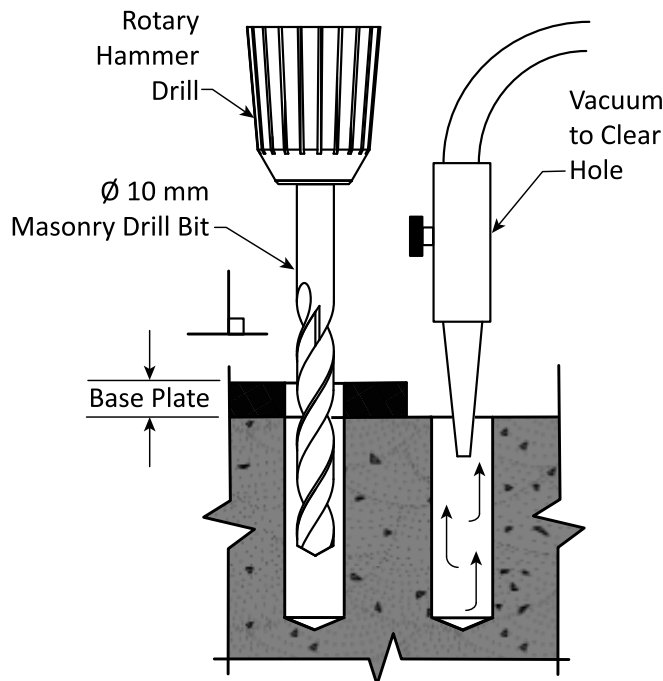

Drill straight; do not let the drill wobble. Use a carbide bit (conforming to ANSI B212.15).

The diameter of the drill bit must be the same as the diameter of the Anchor Bolt. If you are using an M10 diameter Anchor Bolt, for example, use an M10 diameter drill bit.

3. Clean each hole.
Ranger recommends using a vacuum to clean the hole.
Do **not** ream the hole. Do **not** make the hole any wider than the drill bit made it.
4. Make sure the Washer and Nut are in place, then insert the Anchor Bolt into the hole.

The Expansion Sleeve of the Anchor Bolt may prevent the Anchor Bolt from passing through the hole in the Base Plate; this is normal. Use a hammer or mallet to move the Expansion Sleeve through the Base Plate and into the hole.

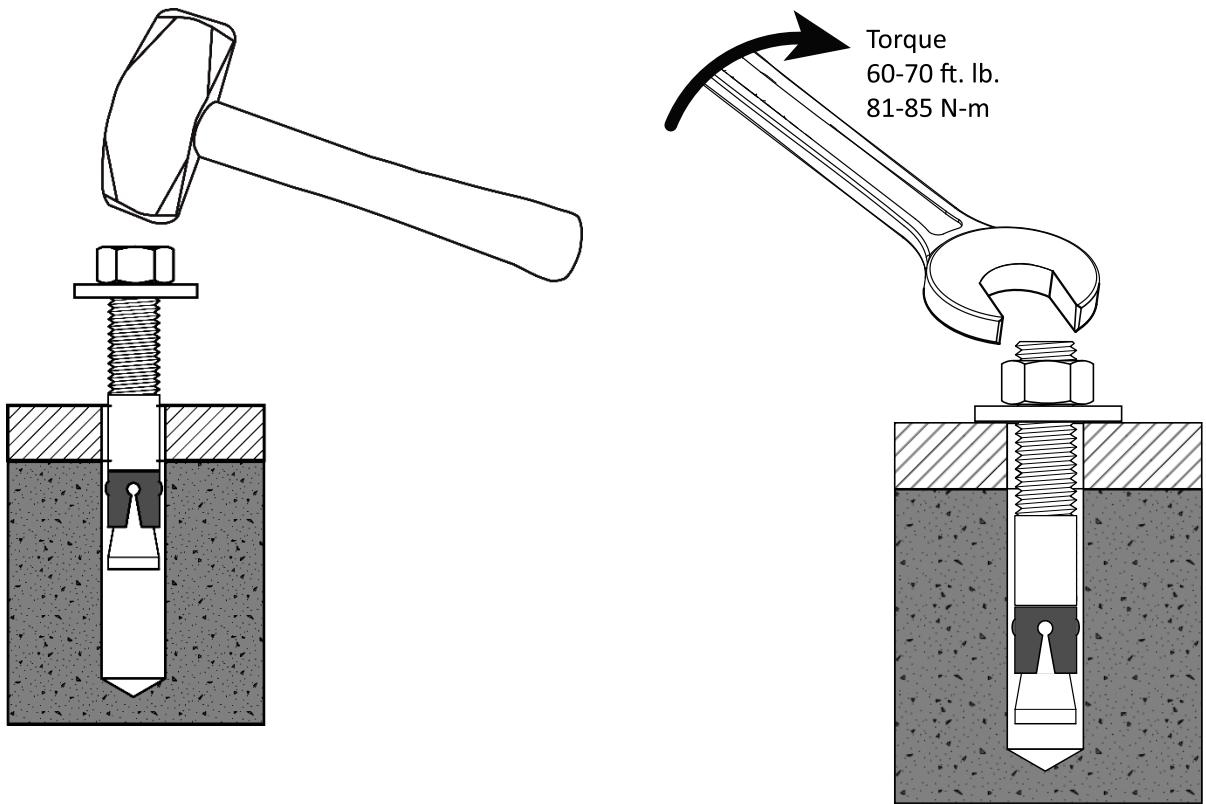

Even using a hammer or mallet, the Anchor Bolt should only go into the hole part of the way; this is normal. If the Anchor Bolt goes all the way in with little or no resistance, the hole is too wide.

Once past the hole in the Base Plate, the Anchor Bolt eventually stops going down into the hole as the Expansion Sleeve contacts the sides of the hole; this is normal.

5. Hammer or mallet the Anchor Bolt the rest of the way down into the hole.

Stop when the Washer is snug against the Base Plate.

6. Wrench each Nut **clockwise** to the recommended torque, 60 – 70 ft-lb / 81 – 95 N-m.

Important: Do **not** use an impact wrench to torque the Anchor Bolts.

Wrenching the Nut forces the Wedge up, forcing out the Expansion Sleeve and pressing it tightly against the Concrete.

Connect to a Power Source

The Balancer is configured to use a 220 VAC, 50/60 Hz power source. The Power Cord must be connected to a 15 amp breaker.

A Power Cord with *no Plug* is provided with the unit. You must have a licensed Electrician wire the open end of the Power Cord to an appropriate 220 VAC Plug.

Refer to [Wiring Diagram](#) for a wiring diagram.

⚠ WARNING All electrical work **requires a licensed Electrician**.

Additional electrical information:

- Operation with no Ground can damage electronics and could create a shock hazard for personnel.

-
- The Balancer includes a case (chassis) ground terminal. In case of installations in a high EMF environment with strong induced currents that could interfere with the balance measurements connect this terminal to ground.
 - Damage caused by improper electrical installation voids the warranty.
 - Most electrical codes require “hard wiring” when the machine is bolted to the floor. Consult a licensed Electrician regarding the applicable codes for your location.

⚠ WARNING **For generator users and or areas with frequent brown-out conditions.** Premature electrical component and Motor failure due to excessive high or low voltage is **not** covered under warranty. Verify that the Generator or facility electrical service can provide the required current and voltage. While voltage variations are common ($\pm 5\%$) both high and low voltage episodes in excess of 15% to 20% can cause Electric Motor overheating and premature Motor failure.

Low voltage will cause the Motor to draw more electrical current to deliver the same amount of force to the Spindle. Excessive current overheats the Motor Windings, eventually burning through the insulation and resulting in complete Motor failure.

High voltage episodes can cause premature failure of electrical components due to overheating.

Test the Balancer

To test the Balancer for normal operation:

1. Turn the Balancer On/Off switch to On.

The Display Panel shows **Bal** on the Inner Window and **116** on the Outer Window, followed by default Wheel dimensions.

(The **116** is the software version; it may differ on your Balancer.)

2. Mount a standard steel Wheel of a size you commonly balance.

Refer to **Mounting a Wheel** for specific mounting instructions.

3. Move the **Inner** Arm to the **Inner** Edge of the Wheel; return the arm to its rest when you hear the Balancer beep.
4. Move the **Cover** down over the Wheel; the width will automatically be entered.
5. When the Cover is lowered, the Wheel will automatically begin to spin clockwise.

If the Wheel does not spin or spins counterclockwise instead of clockwise, turn the Balancer off and contact your dealer, visit www.bendpak.com/support/, or call **(805) 933-9970**.

Final Checklist Before Operation

Make sure these tasks have been properly completed **before** using your Balancer:

- Review the Installation Checklist to make sure **ALL** steps have been performed.
- Make sure the Balancer is **PROPERLY** receiving power from the power source.
- Check to see that all Anchor Bolts are in position and **CORRECTLY** tightened.
- Leave the Manual with the owner/operator.

Operation

This section describes how to use your LS45DS Wheel Balancer.

About the LS45DS Wheel Balancer

The LS45DS Wheel Balancer is a computer-controlled Wheel Balancer that provides fast, accurate Wheel balancing for a wide variety of Wheels. It optimizes Wheel weight placement using Laser-Spot™, which indicates weight placements on the Wheel using a red laser line and Sonar technology to determine the wheel width.

 **WARNING** **NEVER** look directly into the Laser. Doing so may damage your eyes.

Usage Precautions

Keep the following in mind while you use your Balancer:

- Make a visual inspection of the unit **before each use**. Do not operate your Balancer if you find any issues. Instead, take the unit out of service, then contact your dealer, visit www.bendpak.com/support/, or call **(805) 933-9970**.
- Keep the work area clean, dry, and well lit. Dirty, cluttered, and dark work areas increase the chances of an accident happening.
- Do not remove the Storage Trays unless instructed to do so by Ranger Support. There are no user serviceable parts underneath.
- When using the product, you **must** wear appropriate work clothing: leather gloves, non-skid steel-toed work boots, and an industrial back belt. Keep hair, jewelry, and clothing away from the unit.
- When using the product, **the operator must always wear ANSI-APPROVED eye protection**: safety glasses, a face shield, or protective goggles.

 **WARNING** Always wear ANSI-approved eye protection. Although rare, an accident could cause significant injuries to your eyes. **Do not look directly into the laser. Doing so may damage your eyes.**

- Only authorized personnel may use the unit. Keep children and untrained personnel away.
- Do not use the unit in a wet environment or expose the Balancer to rain or excess moisture.
- If an extension cord is necessary, use the shortest available cord with a current rating equal to or more than that of the equipment. Cords rated for less current than the equipment may overheat. Care should be taken to arrange the cord so that it will not be tripped over or pulled.
- Do not use the unit in the vicinity of open containers of flammable liquids.
- Clean the unit according to the instructions in **Maintenance**.
- Read the entire *Installation and Operation Manual* before using the unit.
- **IMPORTANT NOTE! To Balance a 43" (1100 mm) Tire the Outer Arm and Outer Arm Mount Bar must be removed. All data for this size tire must be entered manually.**

Viewing Information on the Display Panel

Data about the Wheel you are balancing, and the test modes is provided on the Display Panel.

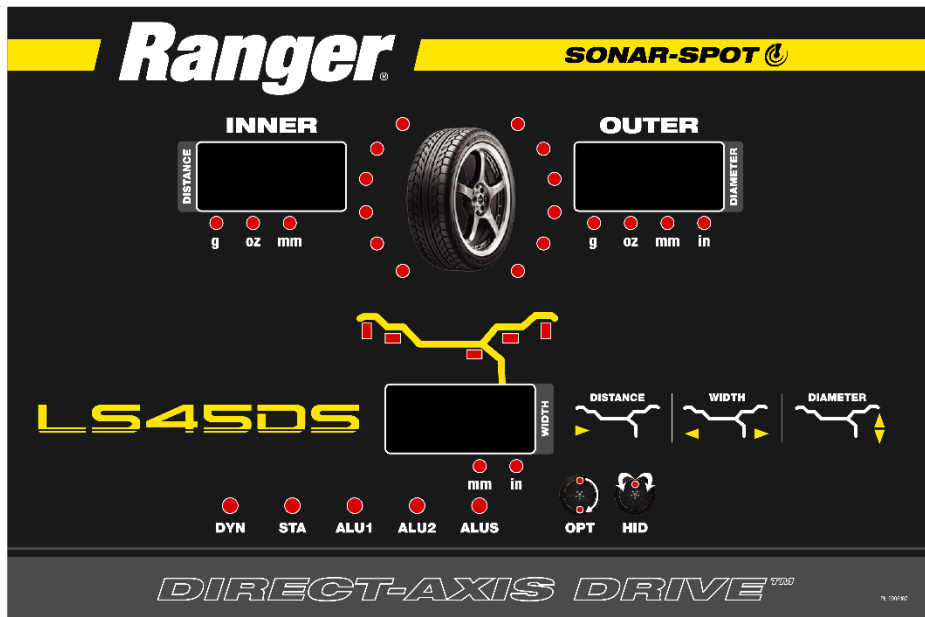

Note: There are no controls or buttons on the Display Panel, only information.

The Display Panel is separated into sections:

- **Inner / Distance Window.** During the Measurement phase of balancing this Window displays the distance from the edge of the Balancer to the inner edge of the Wheel (measured by the Inner Arm). During the Weight or Balance correction phase This window displays the weight to be added to the inner plane of the Wheel.

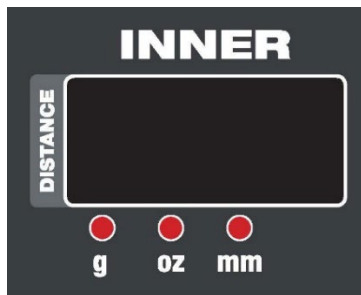

- **Outer / Diameter Window.** During the Measurements phase, this Window displays the Diameter of the Wheel. During the Weights phase, it displays the correction weight to be added to the outer plane of the Wheel.

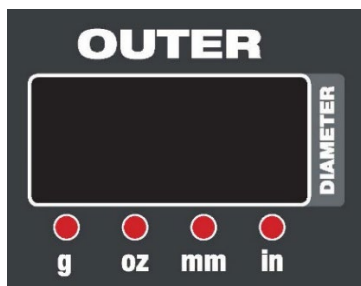

- **Width Window.** During the Measurements phase, this Window displays the Width of the Wheel (determined automatically from the measurements taken by the Inner arm and the Sonar).



- **Indicators around the Wheel.** When Weight correction needs to be added to a Wheel, raise the Cover, and turn the Wheel slowly by hand while watching the indicators on the appropriate side of the Wheel. When all of the indicators are lit, the Wheel will lock automatically, and the laser will indicate the exact spot to place the Weight.



- **Weight Location indicators.** The appropriate weight location indicators illuminate (red) to indicate where the Balancer expects you to place the weights to correct the Wheel balance, based on the Balancing Mode.

If the wrong weight indicators illuminate, stop the balance, and begin again. If you apply weights to the Wheel in a location other than what the Balancer expects, the Wheel will not balance correctly.

The figure below details the available weight locations.

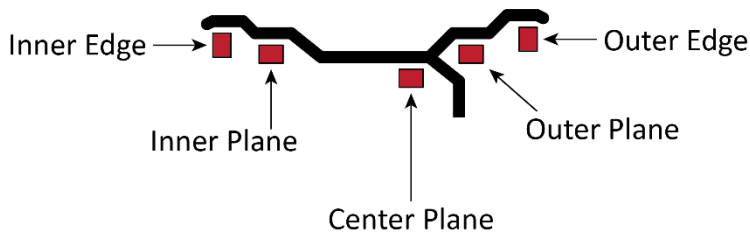

- **Balancing Mode indicators.** DYN, STA, ALU1, ALU2, ALUS, OPT, and HID. When a Balancing Mode is selected, the appropriate indicator illuminates.

Note: OPT indicates the Optimize Function, which is not a Balancing Mode. It is an optional procedure to increase the balance accuracy in a Wheel that is more than 1 oz. (30 grams) out of balance.

About Planes

If you were to split a Wheel down the center (as shown below), it would be divided into two “Planes,” an Inner plane and an Outer plane.

Balancing a Wheel on **both** planes at the same time is the most effective method. Of the five Balancing Modes (DYN, STA, ALU1, ALU2, and ALUS) supported by the LS45DS, four of them balance on both planes at the same time.

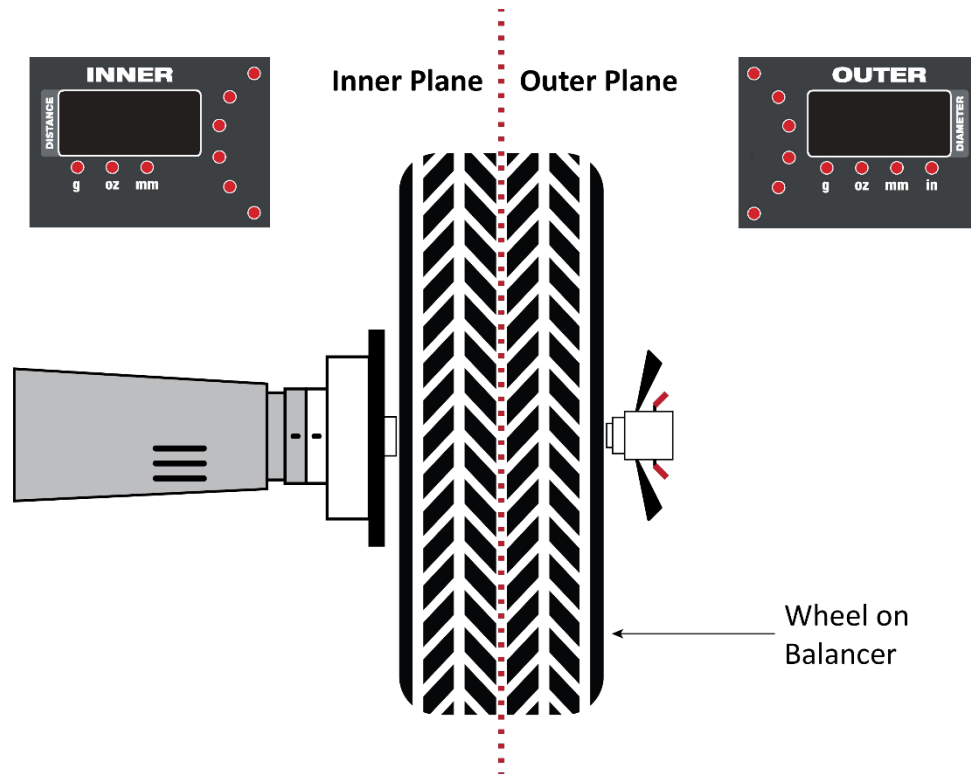

The fifth mode, Static (STA), is generally included for older automobile Wheel designs (of various widths) or motorcycle Wheels. Some examples are wheels that are not wide enough (4-in. or less) to be balanced on both planes at the same time. This function recommends weight placement to the inner plane. Other STA candidates are intended for wheels wider than 4-in. that are Vintage Custom (i.e., Cragar, American, etc.) rims to omit outer rim weight placement for appearance. Note that a Static balance is generally not as complete as other balance modes.

Because balancing a Wheel on both planes is critical to using the LS45DS, the Display Panel shows a two-plane view of the Wheel being balanced.

The Inner “Plane” is on the left (based on the main placement method for Wheels on the Balancer, where the visible Rim on the outside) and the Outer “Plane” is on the right.

The INNER Window displays the correction weight to place on either the Inner Edge, or the Inner Plane weight locations.

The OUTER Window shows how much weight to place on either the Outer Edge or the Outer Plane weight locations.

The Placement Indicators, six per Plane, all light up when the best weight location is reached.

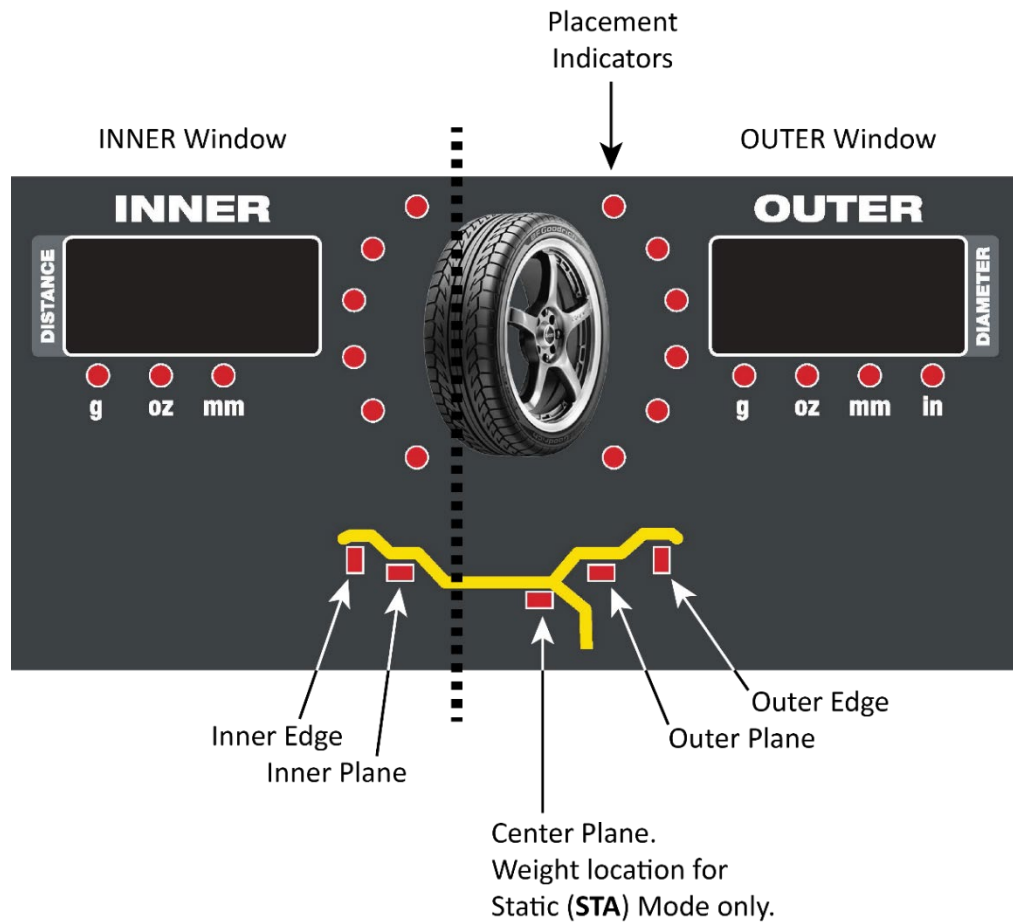

About Measurements

There are three Wheel measurements that are important to understand for correct balancing.

The LS45DS determines these measurements automatically when you use the Inner Arm and the Sonar.

The three measurements are:

- **Distance.** The distance from the side of the Balancer to the Inner Edge of the Wheel. Measured by the Inner Arm.
- **Diameter.** The distance from Outer Edge to Outer Edge. Automatically measured by the Inner Arm.
- **Width.** The distance from the Inner Edge of the Wheel to the Outer Edge. Determined automatically from the Inner Arm Distance and the Sonar values.

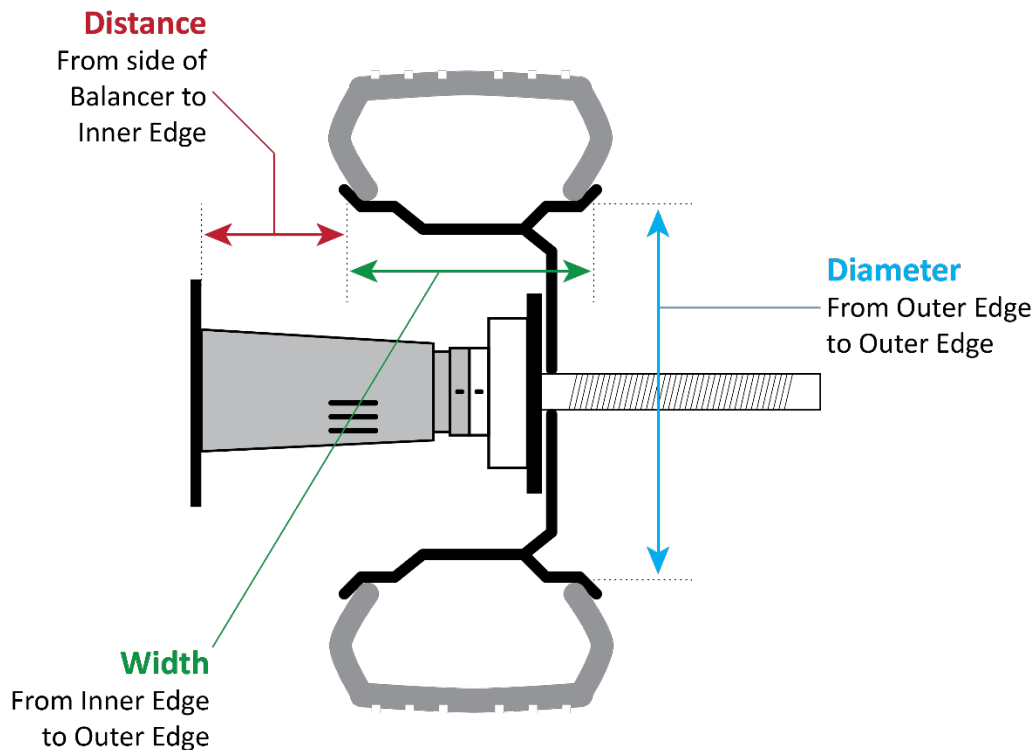

The LS45DS Control Panel

The Control Panel is used to input data and control aspects of the Balancer during both the Measurements and Weights phases.

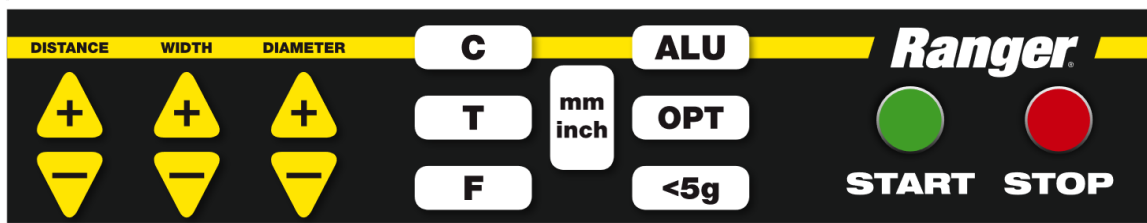

- **Distance, Width, Diameter + / – buttons.** Used to change the Distance, Width, and Diameter settings during the Measurements phase of the balancing session (before the Wheel is spun). Only needed if you want to enter these values manually; otherwise, use the Inner Arm and Sonar to have the LS45DS determine these values automatically.
- **C button.** Used for calibrating the Balancer.

Important: *The Balancer is delivered from the factory already calibrated.* There is no reason to calibrate it again when you first receive it. Calibration is only required if multiple bad balances are reported.

The **“C”** button is also used in conjunction with the **Stop** button to enable/disable the automatic Wheel spin when the Cover is lowered. Press **Stop-C** to toggle off, press **Stop-C** again to toggle back on.

- **T button.** Performs a test of the Balancer software.
- **F button.** Switches between Dynamic and Static Modes.
- **mm / inch button.** Toggles between millimeters (mm) and inches (in.) for those balancer windows that displaying these measurements.

NOTE: To switch between grams (g) and ounces (oz) when a window shows weight values, press, and hold the **Stop** button and then press the **Distance +** button.

- **ALU button.** Press to switch between Dynamic Mode and the three ALU Modes.
- **OPT button.** Used with the Optimize Function.
- **<5g button.** Press and hold to see the *exact* unbalanced values. Otherwise, the Balancer rounds values.
- **Start button.** Starts the Wheel spinning, which can also be done by lowering the Cover.
- **Stop button.** Stops the Wheel from spinning and releases the automatic brake when you have added weight to the Inner Plane and want to move on to the Outer Plane.

Also used with the **C button** to toggle the Wheel starting to spin automatically when you lower the Cover. Press **Stop-C** to toggle off, press **Stop-C** again to toggle back on.

Mounting a Wheel

When you want to balance a Wheel, the first step is to mount it on the Shaft.

Important: All Wheels should be mounted so that the inside goes on the Shaft first.

There are three methods to mount a Wheel onto the Shaft using the Collets supplied with the Balancer:

- **Front-Collet Mounting.** The preferred method, as it generally produces the most accurate balancing results.

An appropriately sized Mounting Collet is installed after the Wheel, then the Quick Nut.

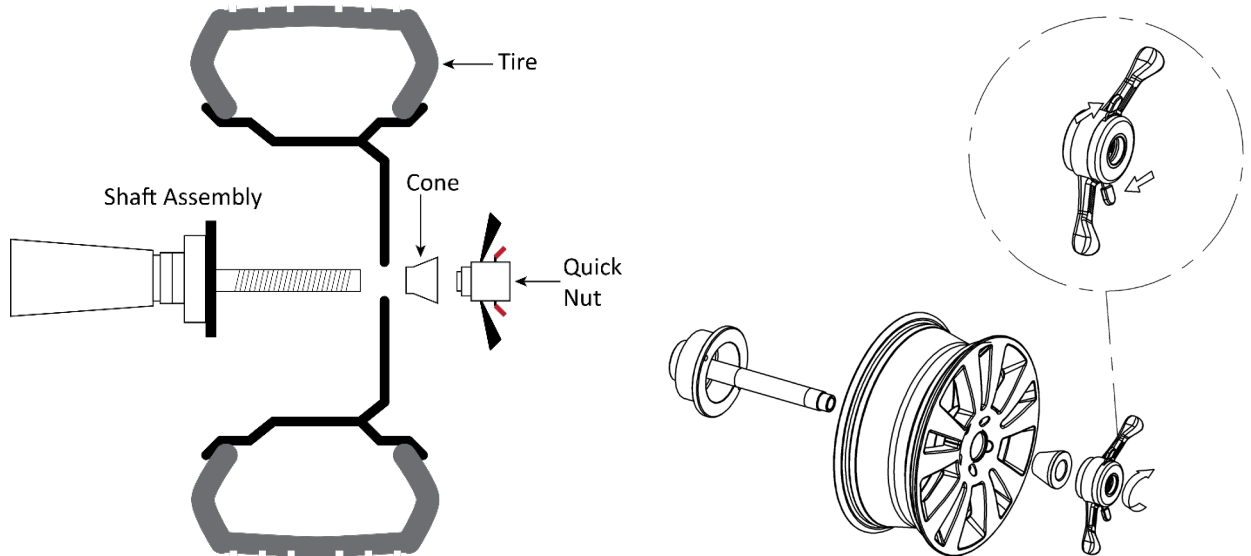

- **Rear-Collet Mounting.** Use this method if the Wheel you are balancing cannot be mounted with Front-Collet Mounting.

The Spring goes on first, then an appropriately sized Collet, the Wheel, the Quick Nut Cup, and finally the Quick Nut.

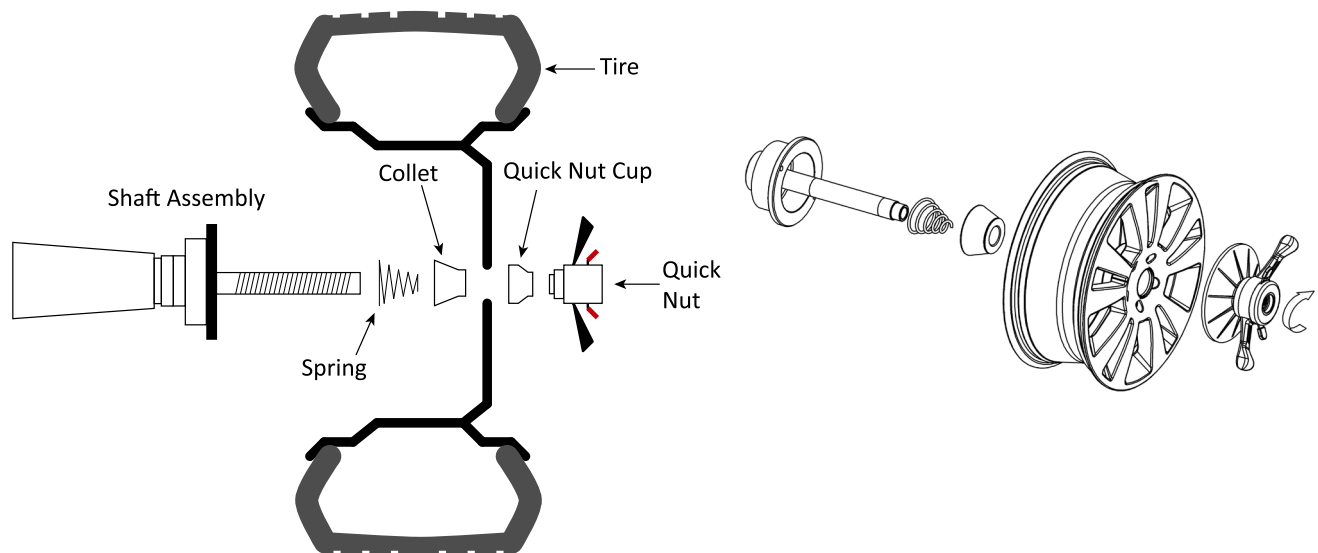

- **Dual-Collet Mounting.** Generally used only for some aftermarket or OEM performance Wheels that have a center hole that is deep enough to allow the use of two Collets on the Shaft.

The Spring goes on first, then an appropriately sized Collet, the Wheel, a second appropriately sized Collet, and finally the Quick Nut.

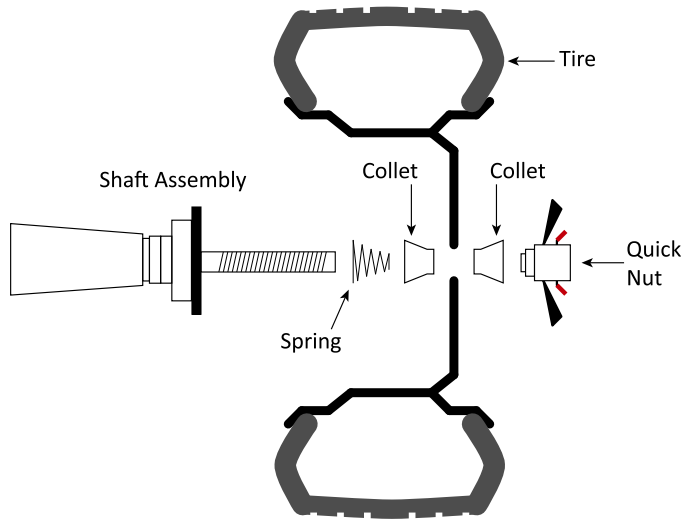

- **Lug-Centric Pressure Plate.** Generally used for some OEM performance Wheels that have a **center** opening that requires mounting based on pressure from the Lugs.

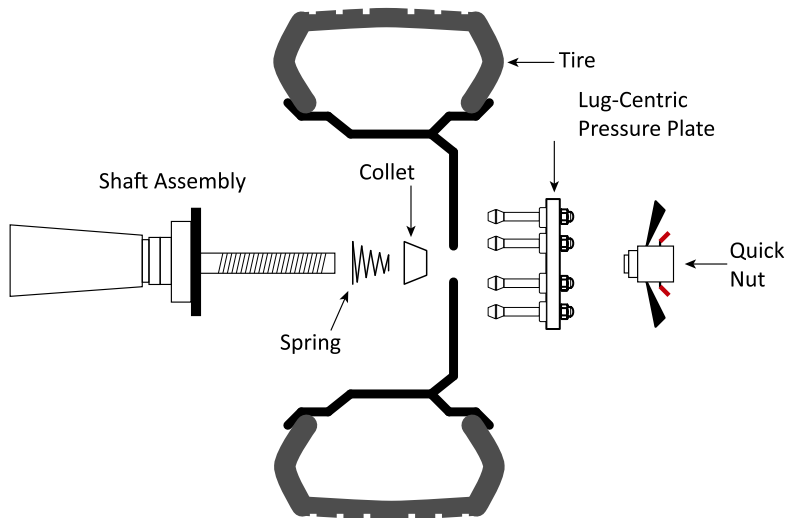

Important: Do not hammer or hit the Quick Nut to tighten it. You will damage the Quick Nut, which is not covered under the Warranty.

To mount a Wheel using the Lug-Centric Pressure Plate:

The Lug-Centric Pressure Plate mounts the wheel to the Balancer through the Wheel's Mounting Lug openings.

1. Always wear ANSI-approved eye protection: safety glasses, face shield, or goggles when operating the Balancer.

-
- The Lug-Centric Plate is delivered with three sets of Lug Pins (5 each) to address wheels that use Tapered and Radius (Ball) Tapered Lug Bolts.

- 92mm Lug Pin for Tapered Lug Bolts (use with wide wheels)

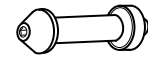

92mm Tapered Lug Pin

- 114mm Lug Pin for Tapered Lug Bolts (use with narrow wheels)

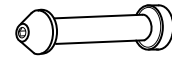

114mm Tapered Lug Pin

- 101mm for Radius or Ball Tapered Lug Bolts

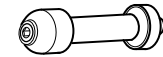

101mm Radius Lug Pin

- Determine which Lug Pin will allow the Quick Nut sufficient thread to tighten down and apply pressure to the Wheel to be balanced.
- Mount the appropriate Lug Pins onto the Pressure Plates' Movable Arms and hand tighten, then secure with the 5mm hex key provided.
- Use the plastic caliper provided to Measure the distance between the two adjacent Wheel Lug Openings. Tighten the Lock Nut on the Caliper to lock the distance.

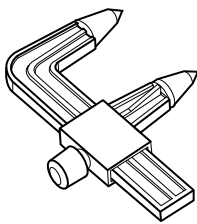

- Use the Plastic Caliper to adjust the Lug-to-Lug distance on the Lug Centric Pressure Plate by pushing the Caliper points into the Lug Pins and adjusting the spacing as required.
- Carefully turn the Pressure Plate over to allow access to the Cap Nuts on the Back of the Pressure Plate. Exercise caution to prevent moving the Lug-to-Lug distance while rotating the Plate.
- Using a 17mm open end wrench tighten the Cap Nuts on the back of the Pressure Plate.
- Place the spring on the Balancer Shaft.
- Select the Mounting Collet that best fits the center hole of the Wheel and place it on the Balancer Shaft.
- Lift the Wheel and put it onto the Shaft, then slide it back towards the Shaft Flange. Move the Wheel until its center opening rests on the Collet. You may need to lift the Wheel slightly when positioning a Collet in the center hole of the Wheel.
- Slide the Lug-Centric Pressure Plate until it meets the wheel then align the Lug Pins with the Lug openings in the Wheel.
- While holding the Wheel and Pressure Plate in place, slide the Quick Nut over the Shaft while holding the Quick-Release Levers next to the Wings.
- Release the Quick-Release Levers.
- Turn the Wings to fully tighten the Quick Nut, and thus the Wheel, in place.

You may want to spin the Wheel some as you tighten the Quick Nut; this can help ensure strong, secure fit.

Important: Do not hammer or hit the Quick Nut to tighten it. You will damage the Quick Nut, which is not covered under the Warranty.

Balancing Modes

Balancing Modes (5 Modes) are based on the locations where the weight is installed to balance the Wheel:

- **Dynamic (DYN).** The most common Balancing Mode; used with steel rims, and when weights placed on the visible side of the wheel is not a concern to the customer. If the Wheel is out of balance, weights go on the Inner Edge and the Outer Edge.

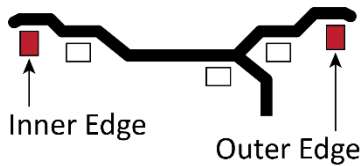

- **Static (STA).** Typically used for older Wheels of various widths and most always used for rims under 4 inches in width. Static also includes most motorcycle Wheels. Weights are placed to the inside of the wheel (Inner Plane).

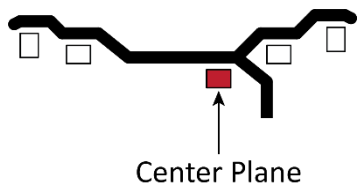

- **Aluminum 1 (ALU1).** Used on Aluminum Alloy Wheels when you want the weights placed on the Inner Plane and the Outer Plane.

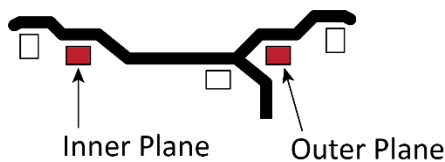

- **Aluminum 2 (ALU2).** Used on Aluminum Alloy Wheels when you want the weights placed on the Inner Edge and the Center Plane. Weights are placed so they are generally not visible to the outside.

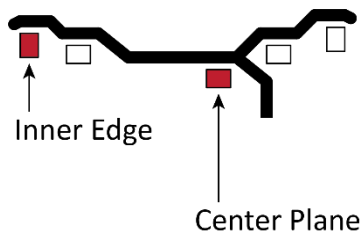

- **Aluminum Special (ALUS).** Used on Aluminum Alloy Wheels where the weights need to be placed on the Inner Plane and the Center Plane.

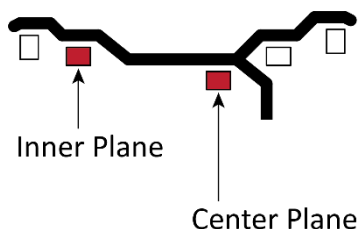

OPT (Optimize) Function

Not a Balancing Mode. The Optimize Function is an optional procedure to lessen the imbalance in a Wheel that is more than 3 ounces (90 grams) out of balance.

For more information, refer to [Using the Optimize Function](#).

HID (Hidden)

Applies Adhesive Weights on the Center Plane in multiple locations mounted behind spokes.

This prevents weights from being as visible.

Refer to [Hidden Weight Balancing](#) for specific instructions for using this Balancing Mode.

Before You Balance a Wheel

Before you balance a Wheel, you should:

- **Remove all existing Weights from the Wheel.** If the Wheel already has Weights on it, either Clip-On or Adhesive, remove them. They will throw off the new balancing process.
- **Thoroughly clean the Wheel.** Mud or dirt on the Wheel will impact the new balancing process. Also, when adding Adhesive Weights, clean the area well first.
- **Wear appropriate eye protection.** Do not use the unit unless you are wearing ANSI-approved eye protection: safety glasses, a face shield, or protective goggles.
- **Make sure the area is clear.** Only the operator should be near (within 30 feet) of the Wheel Balancer while the Wheel is turning.

Dynamic Balancing

Dynamic Balancing evaluates and balances a Wheel with weights clipped to both the Inner and Outer Edges.

The Clip-On Weight may be installed on the Inner Edge, the Outer Edge, or both.

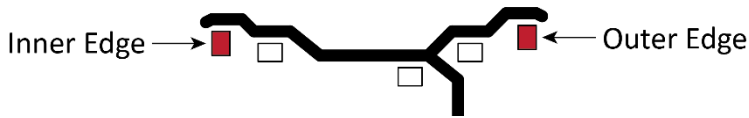

To Balance a Wheel using Dynamic Mode:

1. Make sure you are wearing ANSI-approved eye protection: safety glasses, face shield, leather gloves and goggles.
2. Visually inspect the Balancer to verify everything is in place. **The Cover should be up.**
3. Make sure the Wheel you want to balance is both clean (remove mud, dirt, grease) and free of any weights that may have been installed previously, then mount it on the Balancer.

Refer to [Mounting a Wheel](#) for mounting instructions, if needed.

4. Turn the Balancer Off and then back On, to reset it.

On power up, the software version will appear in the Inner and Outer Windows, all the position indicators will flash, followed by default Wheel dimensions.

5. Pull out the Inner Arm and place it against the Inner Edge of the Wheel (where the inner weight will be clipped) and hold it there without moving; **wait for the Balancer to beep**. See figure below.

Place the Inner Arm
on the Inner Edge.
Wait for the beep.

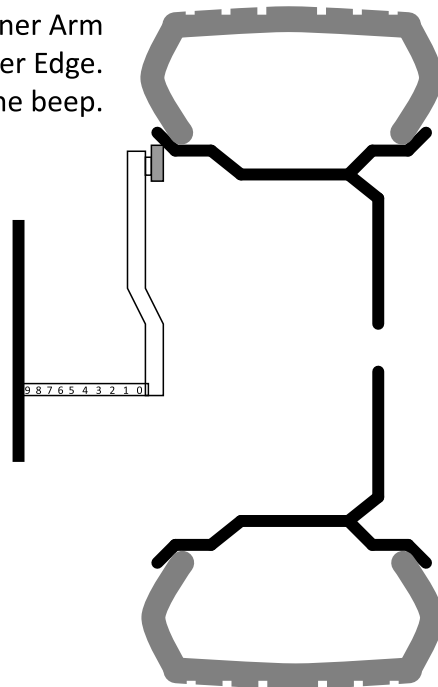

6. When the Balancer beeps, return the Inner Arm to its rest position.

The Inner Window shows the Distance from the edge of the Balancer to the Wheel's Inner Edge.

The Inner Window always shows distance in millimeters (mm).

7. Lower the Cover to automatically determine the width and to evaluate the wheel for balance.

This data may also be entered manually. If you wish to turn **off** the automatic spin feature, press and hold **STOP**, then press **C**. You will then be required to press **START** to spin the Wheel.

To turn the Automatic Spin feature back on, repeat the same process.
8. When the Balancer beeps, the wheel will spin to a stop. Return the Cover to its rest position.
9. When the Wheel stops, observe the values in the Inner and Outer Windows on the Display Panel; these amounts indicate the amount of weight to be applied to each plane to correct the imbalance.

The measurement units (grams or ounces) is indicated under the Inner and Outer Windows.

To switch between grams and ounces, press and hold **Stop**, then press **Distance +**.

The weight value that appears in the Inner Window is to be added to the Inner Edge of the Wheel.

The weight value that appears in the Outer Window is to be added to the Outer Edge of the Wheel.

If either value is over 1 oz / 30 grams, **Opt** appears in the Width Window, meaning that the Optimize Function is available. Refer to **Using the Optimize Function** for more information.
10. Lift the Wheel Cover.
11. Turn the Wheel slowly to find the best location to put the weight on the Inner Edge (if the Inner Window shows **00**, do not add any weight to the Inner Edge).

The Inner Plane indicators illuminate or go out as you move the Wheel to find the best location to place the weight. See figure below.



↑
Indicators for
Inner Plane

↑
Indicators for
Outer Plane

12. When the Wheel is in the right location, the Balancer automatically locks the Wheel in position and a laser generated line appears at the spot on the Wheel where the Balancer has determined additional weight is required.
13. Add the correct amount of clip-on weight centered on the laser line location. Refer to the figure on the next page.

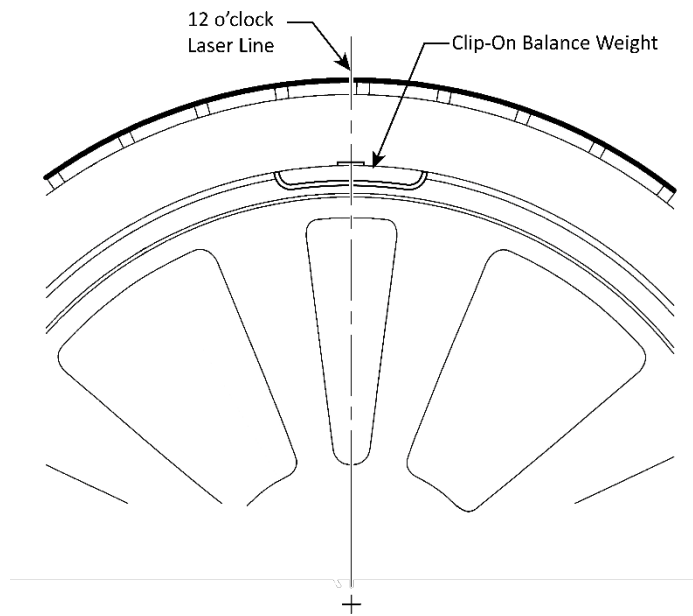

14. Press **Stop** to release the Wheel from the automatic lock.
15. Turn the Wheel slowly again to find the best location for weight on the Outer Edge (again, assuming it needs weight; if the Outer Window shows **00**, do not add weight to the Outer Edge).
16. Add the correct amount of Clip-On Weight at the 12 o'clock position on the outer rim when the Wheel locks and the laser beam appears.
17. Lower the Wheel Cover to spin the Wheel again.

The Wheel is balanced when both the Inner and Outer Windows show **00**.

Upper and Lower Laser Instructions

⚠ WARNING Do **not** look directly into the laser. Doing so may damage your eyes.

Upper Laser Instructions. The Laser will clearly define the inside and outside Weight position in Dynamic Balancing Mode.

1. The Laser function is enabled when the Dynamic Balancing Mode is selected. The Laser function is disabled in other Balancing modes.
2. After the Balancer has determined an imbalance is present and the Wheel has stopped, slowly rotate the Wheel until all the inner or outer position lights are illuminated and the wheel locks. The Laser will then activate to indicate the 12 o'clock position of the clip-on weight correction.

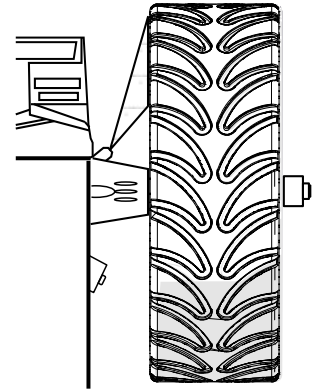

Lower Laser Instructions. The Lower Laser Function will identify the 6 o'clock position directly below the shaft. This function is to be used in the ALU modes only.

1. The Lower Laser function is disabled when shipped from the factory. Follow the process below to enable the Lower Laser function.
2. When the Lower Laser Function is activated, and an ALU Mode is selected and an imbalance is detected, rotate the Wheel slowly until all the position lights illuminate, and the Lower Laser will activate to indicate the 6 o'clock position under the Balancer shaft for the weight placement.

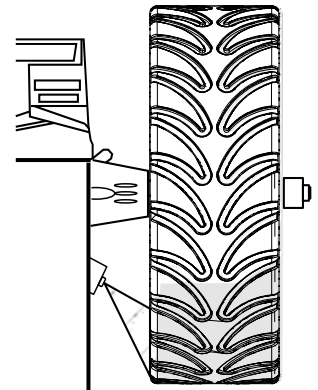

NOTE: When the Lower Laser is enabled, **all** balancing modes using stick-on correction weights are attached at the 6 o'clock position only. Clip-on weights are attached at the 12 o'clock position indicated by the upper Laser.

NOTE: When the Lower Laser is enabled the internal measuring gauge cannot be used to apply weights.

To Enable and Disable the Lower Laser:

1. Press **C** and **T** simultaneously to enter the Parameter Program.
2. In sequence, press and hold the **Distance +** key then the **-** key and finally the **ALU** key to access the Balancer settings.
3. Press the **Distance +** key five times to access the Lower Laser Function. The Leftmost display will read **LAS** and the right display will read **OFF**.
4. Press the **Width +** key to enable the Lower Laser. The rightmost window will now display **ON**. The Lower Laser is now enabled.
5. To disable the Lower Laser Function, repeat the steps above but change the Lower Laser status in step 4 to Off.

Static Balancing

Static Balancing is typically for older Wheels, vintage custom wheels, and similar. Typically, where the customer does not want weights either visible and/or applied to a chrome or polished surface. Also used when rims measure under 4 inches wide and with most motorcycle Wheels.

Note: The Optimize Function is **not** available for Static Mode.

If the Wheel is out of balance, weight is installed on the Center Plane when using Static Mode.

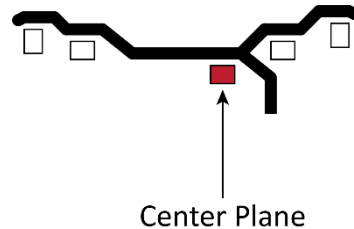

To Balance a Wheel using Static Mode:

1. Make sure you are wearing ANSI-approved eye protection: safety glasses, face shield, or goggles.
2. Visually inspect the Balancer to verify everything is in place. The Wheel Cover should be **up**.
3. Mount the Wheel to balance.

Refer to **Mounting a Wheel** for mounting instructions, if needed.

4. Turn the Balancer Off and then back On, to reset it.
5. In Dynamic Mode measure the distance to the Center Plane. Pull out the Inner Arm and place it on the Center Plane and hold it there; **wait for the Balancer to beep**. Refer to the figure on the right.
6. When the Balancer beeps, return the Inner Arm to its rest position.
7. On the Control Panel, press the **F** (Function) button until the **STA** (Static) indicator and the Center Plane indicator is lit.
8. Lower the Wheel Cover; the Wheel spins briefly.
9. Raise the Wheel Cover when the Wheel stops.

Place the Inner Arm on the Center Plane. Wait for the beep.

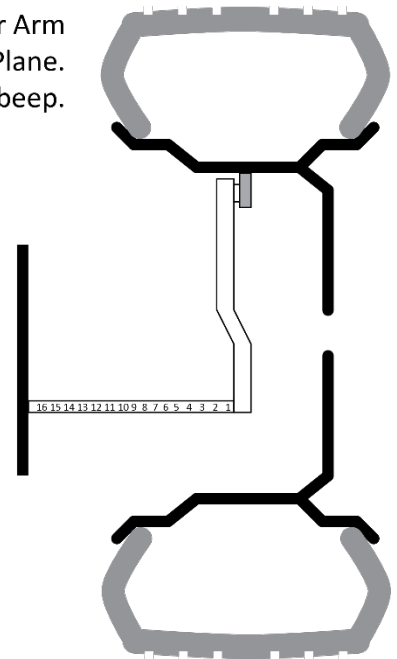

The Inner Window shows **St**, and the Center Plane indicator is lit. The display shows the weight required to correct the Center Plane.

10. Turn the Wheel slowly to find the best location to put the weight.
11. When the Wheel is in the right location, it automatically locks, and a laser beam appears at the 6 o'clock position. Add the eight centered on the laser location on the center plane.
12. Lower the Cover to spin the Wheel again. The display shows **00** When the Wheel is balanced.

Aluminum Alloy Balancing

The following procedure describes the three Aluminum Alloy (ALU) Modes available.

Important: ALU Modes are for balancing Wheels made of aluminum alloy. The weights can be placed in various locations on these Wheels. *Determine where the weights are to be applied, and then select the appropriate ALU Mode.*

Adhesive Weights are generally used when you are using ALU Modes.

The Wheel Data input depends on the ALU Balancing Mode selected.

See **Upper and Lower Laser Instructions** to enable the Lower Laser function to indicate the 6 o'clock correction weight location.

To balance a Wheel using an ALU Mode:

1. Make sure you are wearing ANSI-approved eye protection: leather gloves, safety glasses, face shield, or goggles.
2. Visually inspect the Balancer to verify all components are in place. The Wheel Cover should be **up**.
3. Mount the Wheel you want to balance.
Refer to **Mounting a Wheel** for mounting instructions, if required.
4. Turn the Balancer Off and then back On, to reset.
5. Begin in the Dynamic Mode (**DYN**). The operator will select **ALU1** or **2** within the procedure. The **ALUS** mode is automatically selected.
6. The instructions for all three of the **ALU** Modes are different:

ALU1

ALU1 Mode is used on Aluminum Alloy Wheels when the adhesive weight correction is to be placed on the Inner and Outer Planes.

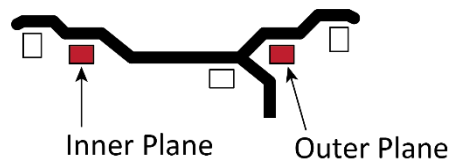

- a. Pull out the Inner Arm, place it on the Inner Plane, and hold it there. See figure to the right.
- b. Listen for the beep.
After the beep, return the Inner Arm to its rest position.
- c. **Press** the **ALU** button to select the **ALU1** Mode.
- d. Close the Cover. The width data will be entered automatically. The Wheel will rotate and stop. *This data may also be entered manually.*
- e. Listen for the beep.
- f. After the beep and the wheel stops, return the Cover to its open position.

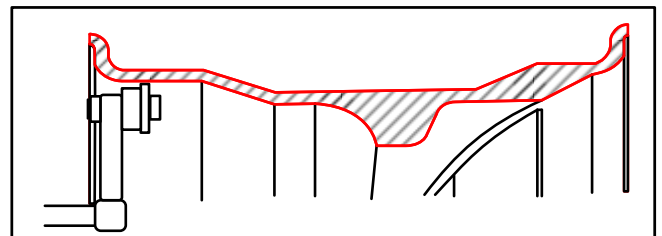

- g. The Balancer displays the correction weights for the inner and outer planes shown on the display panel.
- h. Spin the wheel by hand slowly until all the indicators are illuminated on either the Outer or Inner Planes. The balancer will automatically lock the wheel position and a laser generated line will indicate the weight location on the Wheel.

NOTE: In **ALU1** mode, both Inner and Outer Plane Adhesive Weight locations are at 6 o'clock when the Lower Laser is active.

- i. Place the correction Weight on the Wheel at the 6 o'clock position indicated by the laser and on the Wheel Plane indicated by the **ALU1** mode.
- j. Press **STOP** to unlock the Wheel.
- k. Spin the wheel slowly by hand again until the outside plane indicators are all lit, and the balancer locks the wheel.
- l. Place the weight at the 6 o'clock position indicated by the laser and the plane indicated by the **ALU1** mode.
- m. Lower the Wheel Cover to spin the Wheel again.

The Wheel is balanced when both the Inner and Outer Windows show **00**.

ALU2

ALU2 Mode is used on Aluminum Alloy Wheels when the weight correction is to be Clipped to the Inner Edge and a self-adhesive weight applied to the Center Plane.

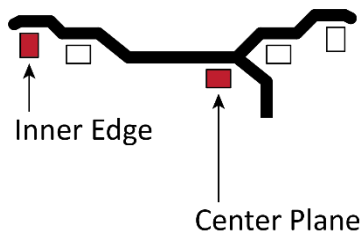

- a. Pull out the Inner Arm, place it on the Inner Edge, and hold it there. See figure below.
- b. Listen for the beep.
- c. After the beep, return the Inner Arm to its rest position.
- d. Press the **ALU** button until **ALU2** is selected and indicated on the Display Panel.
- e. Close the Wheel Cover to spin the wheel. The Balancer automatically stops the Wheel with correction weight values for the Inner Edge and Center Plane shown on the display panel.
- f. In **ALU2** mode, the Inner Edge Clip-On Weight location will be at the 12 o'clock position indicated by the top laser, and the Center Plane Adhesive Weight location will be at the 6 o'clock position indicated by the bottom laser.
- g. Spin the wheel by hand slowly until all the indicators are lit on either the Outer Plane or Inner Edge. The balancer will automatically lock the wheel position and a laser generated line will indicate the weight location on the Wheel.

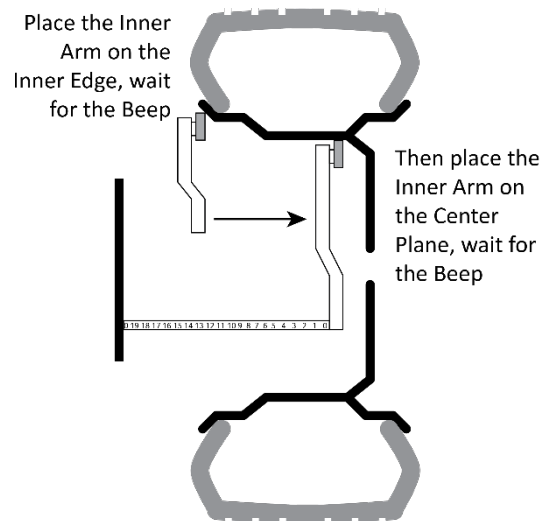

- h. Place the correction Weight on the Wheel at the 6 o'clock position for the Center Plane and 12 o'clock position for the Inner Edge as indicated by the laser.
- i. Press STOP to unlock the Wheel.
- j. Spin the wheel slowly by hand again until the opposite plane indicators are all lit, and the balancer locks the tire.
- k. Place the weight at the positions indicated by the laser.
- l. Lower the Wheel Cover to spin the Wheel again.

The Wheel is balanced when both the Inner and Outer Windows show **00**.

ALUS with Lower Laser

ALUS Mode is used on Aluminum Alloy Wheels where the weights need to be applied on the Inner Plane and the Center Plane.

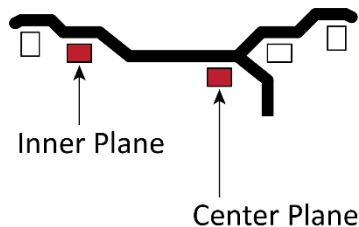

- a. Pull out the Inner Arm, place it on the Inner Plane, and hold it there. See figure below.
- b. Listen for the beep.
- c. After the beep, move the Inner Arm to the Center Plane behind the wheel spokes and hold it there.

Do not return the Inner Arm to its rest position between the two locations.

- d. Listen for the beep. After the beep, return the Inner Arm to its rest position.
- e. Make sure that **ALUS** is selected (this should occur automatically).
- f. If **ALUS** mode is **not** automatically selected, restart the procedure.
- g. Close the Wheel Cover to spin the wheel. The Balancer automatically stops the Wheel with correction weight indications for the inner and center planes shown on the display panel.
- h. Spin the wheel by hand slowly until all the indicators are lit on either the Inner or Center Planes. The balancer will automatically lock the wheel position and a laser generated line will indicate the weight location on the Wheel at the 6 o'clock position.
- i. Press STOP to unlock the Wheel.
- j. Spin the wheel slowly by hand again until the center plane indicators are all lit, and the balancer locks the wheel.
- k. Place the weight at the 6 o'clock position indicated by the laser.

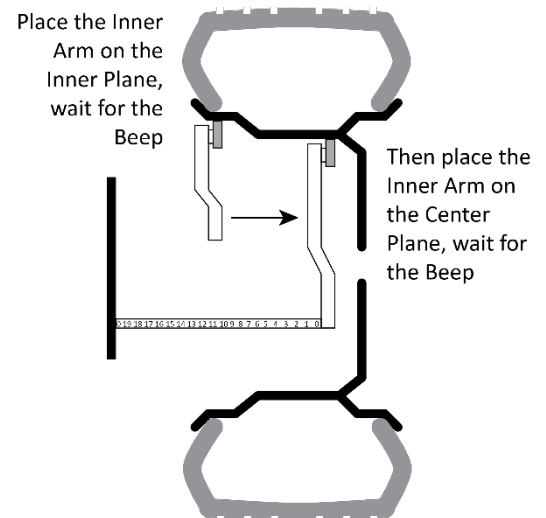

Lower the Wheel Cover to spin the Wheel again. The Wheel is balanced when both the Inner and Outer Windows display **00**.

ALUS without the Lower Laser

ALUS Mode without the Laser uses the Inner Measurement Arm to apply the correction weights on the Inner and Center Plane.

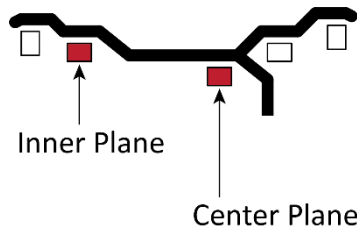

- Verify the Lower Laser is in the **Off** condition.
- Pull out the Inner Arm, place it on the Inner Plane, and hold it there. See figure below.
- Listen for the beep.
- After the beep, move the Inner Arm to the Center Plane behind the wheel spokes and hold it there.

Do not return the Inner Arm to its rest position between the two locations.

- Listen for the beep. After the beep, return the Inner Arm to its rest position.
- Make sure that **ALUS** is selected (this should occur automatically).
- If **ALUS** mode is **not** automatically selected, restart the procedure.
- Close the Wheel Cover to spin the wheel. The Balancer automatically stops the Wheel with correction weight indications for the inner and center planes shown on the display panel.
- Open the Wheel Cover and slowly rotate the Wheel by hand until all the indicators are lit on either the Inner or Center Planes.
- Place the correction weight on the Inner Arm Gauge Head.
- Pull the Inner Arm out until the Gauge Head touches the Inner Plane. When the Center Window displays $\square - -$ and a beep sounds apply the weight.
- Return the gauge to its original position.
- Rotate the Wheel until all the inner indicators are lit.

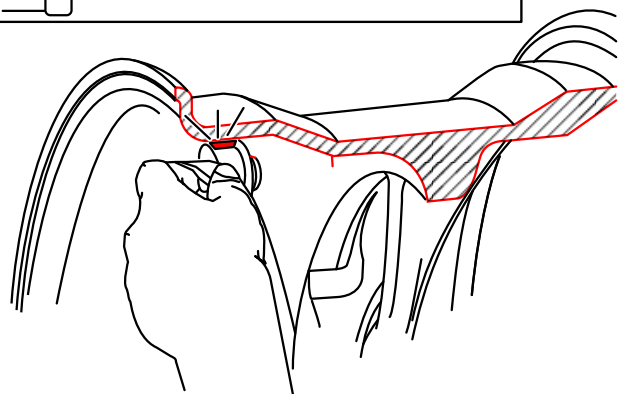
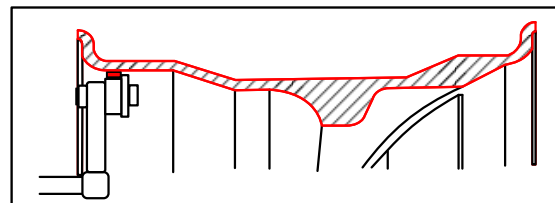
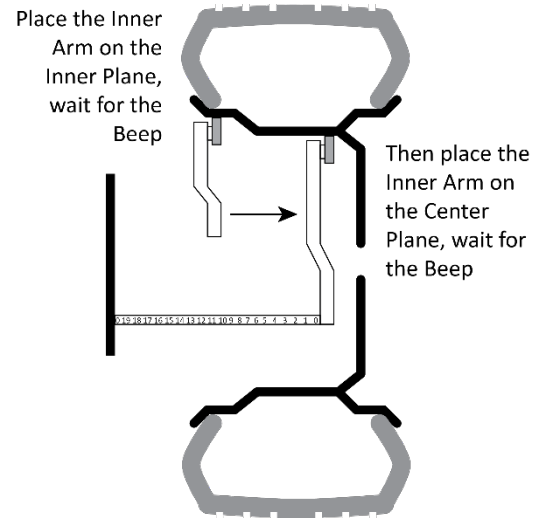

- n. Place the correction weight on the Inner Arm Gauge Head and pull the inner Arm out until the Center Window displays -- □.
- o. Lift up the Lift Arm Gauge Head and apply the Weight.
- p. Return the Inner Arm Gauge to its rest position.
- q. Measure the Wheel's Balance to verify the correction. Repeat the procedure until both windows display 0 and 0.

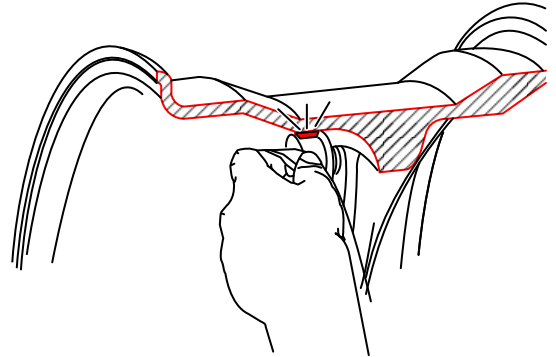
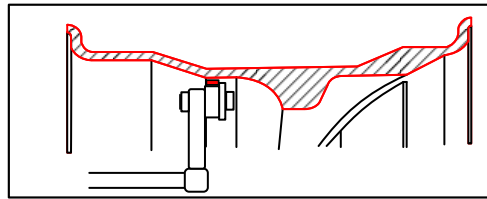

Hidden Weight Balancing

In **ALUS** Mode The Hidden Weight (**HID**) mode allows the operator to hide correction weights behind wheel spokes by dividing the correction weight between two adjacent wheel spokes. See the figure below.

Begin Hidden Weight Balancing in the **ALUS** Mode.

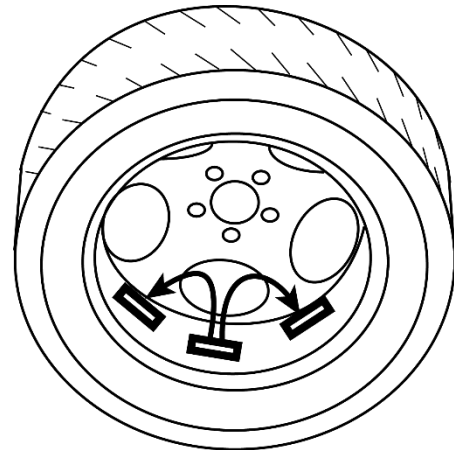
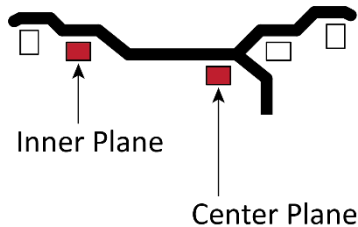

To balance a Wheel using Hidden Weight Mode:

1. Make sure you are wearing ANSI-approved eye protection: safety glasses, face shield, or goggles.
2. Visually inspect the Balancer to verify everything is in place. The Wheel Cover should be **up**.
3. Mount the Wheel to be balanced.

Refer to **Mounting a Wheel** for mounting instructions, if needed.

4. Turn the Balancer Off and then back On, to reset it.
5. The Balancer display panel should indicate Dynamic Balance (**DYN**) mode.
6. Pull out the Inner Arm, place it on the Inner Plane, and hold it there.
7. Listen for the beep.
8. After the beep, move the Inner Arm to the Center Plane just behind the Wheel Spokes and hold it there.

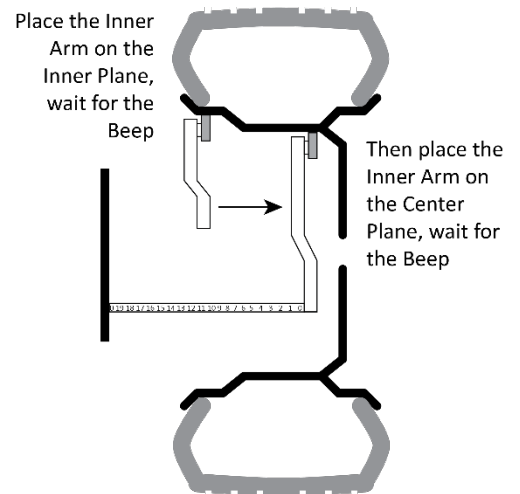

Do **not** return the Inner Arm to its rest location between the two locations. See figure to the right.

9. Listen for the beep.
10. After the beep, return the Inner Arm to the rest position.
11. Make sure that the **ALUS** mode indicator is lit on the Display Panel (the Balancer should enter this mode automatically when the Inner Arm is returned to its rest position).

If **ALUS** mode is **not** automatically selected, restart the procedure.

In **ALUS** mode, both Adhesive Weight locations are at 6 o'clock.

12. Lower the Wheel Cover; the Wheel will spin briefly.
13. Raise the Wheel Cover when the Wheel stops.

The Inner and Outer Windows show the weight correction that is required for the Inner and Center Planes in the **ALUS** Mode.

14. Turn the Wheel slowly to find the best location to apply the Inner Plane weight. All the indicators on the Inner Plane display will light.

When the Wheel is in the right location, it automatically locks, and a laser indicates the spot the Balancer wants you to add the weight.

15. Press **OPT + T** simultaneously. The **HID** indicator should light on the Display.
16. Press **ALU** on the control panel. The Inner and Outer Display Windows should now display **-1-**. See the figure below.

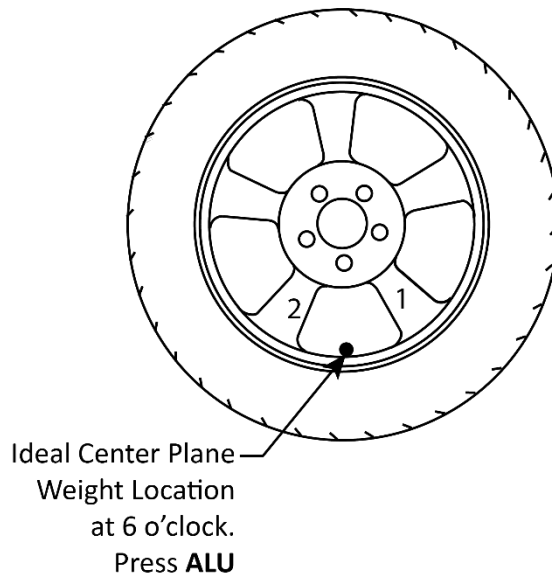

17. Press **Stop** to unlock the Wheel.
18. Rotate the wheel to bring the next closest Wheel Spoke to the **right** of the ideal weight location to the 6 o'clock position. Then Press **ALU**. See the figure below. This indicates to the Balancer where the first hidden weight is to be placed.

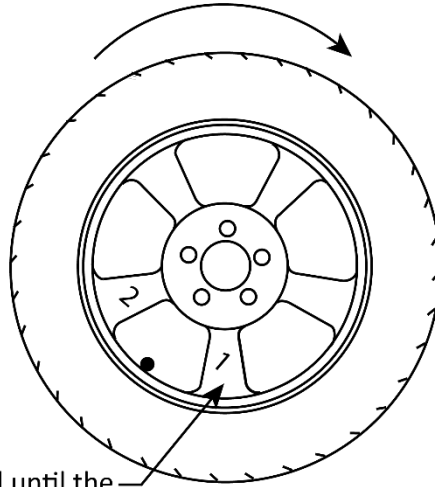

Rotate Wheel until the
closest Spoke to the right
is at 6 o'clock.
Press **ALU**

19. The Inner and Outer Display Windows should now display **-2-**.
20. Rotate the wheel to bring the next closest Wheel Spoke to the **left** of the ideal weight location to the 6 o'clock position. Press **ALU**. See the figure below. This indicates to the Balancer where the second hidden weight is to be placed.

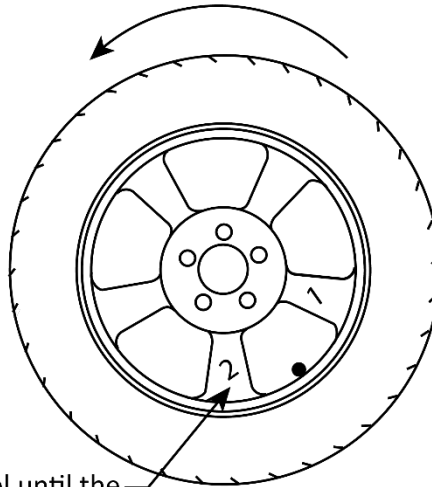

Rotate Wheel until the
closest Spoke to the left
is at 6 o'clock.
Press **ALU**

21. The center Width Display Window should now display **SPD**.
22. Rotate the Wheel back toward position 1, until all the indicators light for position **-1-** (to the **right** of the ideal position) and the Wheel locks. Apply the correction weight shown in the Outer Display Window for position **-1-** behind and as close to the Wheel Spoke as possible. The balancer will split the weight and display the correct weight split for each position.
23. Press **Stop** to unlock the Wheel.

-
24. Rotate the Wheel toward position **-2-** (to the **left** of the ideal position) and when all the Outer Plane indicators light and the Wheel locks, apply the correction weight shown in the Outer Display window position **-2-** on the Center Plane behind and as close to the Wheel Spoke as possible.
 25. Lower the Wheel Cover to spin the Wheel again.
The Wheel is balanced when both the Inner and Outer Windows show **00**.
Repeat the process until the Wheel is balanced to **00**.

Using the Optimize Function

The Optimize Function helps reduce the imbalance of a problem Wheel that is more than 3 ounces / 30 grams out of balance. You are not **required** to use the Optimize Function.

Important: The Optimize Function does not bring a problem Wheel to full balance; instead, it lessens the imbalance of a Wheel that is significantly out of balance. Depending on the state of the Wheel, even if you correctly Optimize a Wheel, it may still be more than 1 ounce / 30 grams out of balance when you are done with the Optimize. In general terms, it can often improve the balance on those problem wheels that come into shops periodically.

When you see **Opt** in the Width Window during a balance, it means the Wheel you are balancing is going to be more than 1 ounces (30 grams) out of balance on one or both planes. Often the cure can include checking and or cleaning the rim's bead area for full seating, breaking the bead and re-soaping the tire's bead, and/or breaking the bead and rotating the tire 180 degrees from the valve stem, and then re-inflating the tire. In addition, ensure that the rim is not bent, and the tire is not severely cupped or too old and possibly separating (older used tires), or the tire not seated completely on the bead due to heavy rust on the rim. Note: If attempts to correct excessive imbalance do not correct the problem – the Wheel Balancer may be showing that the wheel or used tire has an existing problem, beyond balancing.

To Optimize a Wheel:

1. When you see **OPT** in the Width Window during a balance, raise the Wheel Cover, then rotate the Wheel until the indicators next to the Inner Window are all lit.
2. Press the **OPT** button on the Control Panel.
180 appears on the Lower Window and the **OPT** icon on the Display Panel lights.
The Balancer is now in Optimize Mode.
Important: If you use the Balancer to balance a different Wheel or turn the Balancer on and off, the Balancer will be taken out of Optimize Mode.
3. Mark the Collet, the Rim at the Collet, the Rim at the Tire, and the Tire itself.
Tip: Use a Mark that can be removed when you are done with the process but not come off during the process. Using masking tape generally works, using a pen or pencil usually does not. A pen or pencil mark on tape works the best.
4. Remove the Wheel from the Balancer, then use a Tire Changer to take the Tire off the Wheel, rotate the Tire 180°, then put the Tire back on the Wheel.
Make sure not to cover or remove the Marks on the Wheel and Tire.
5. Put the Wheel back on the Balancer, making sure to align the marks on the Collet, the Rim at the Collet, and the Rim at the Tire.
The Mark on the Tire itself will be 180° from the other Marks.

6. Lower the Wheel Cover or press the **Start** button.
7. When the Wheel stops, turn the Wheel until the Inner Placement Indicators are all lit and the Wheel locks in position.
8. Put a Mark at Top Dead Center on the Wheel Rim.
9. Press **Stop** to release the Wheel, then turn the Wheel until the Outer Placement Indicators are all lit and the Wheel locks in position.
10. Put a Mark at Top Dead Center on the part of the Tire next to the Wheel Rim.
11. Remove the Wheel from the Balancer, then use a Tire Changer to take the Tire off the Wheel, rotate the Tire so the two Marks you just put on are aligned, and then put the Tire back on the Wheel.
12. Put the Wheel back on the Balancer and restart the Balancing process that was interrupted by using the Optimize Function.

Manual Wheel Data Input

The LS45DS determines measurement data automatically when you use the Inner Arm and the Sonar, but you can enter measurement data manually if necessary:

- **Distance.** Pull out the Inner Arm to the Inner Edge of the Wheel, note the value on the Distance Ruler, and enter that value using the **Distance +** and **-** buttons on the Control Panel.

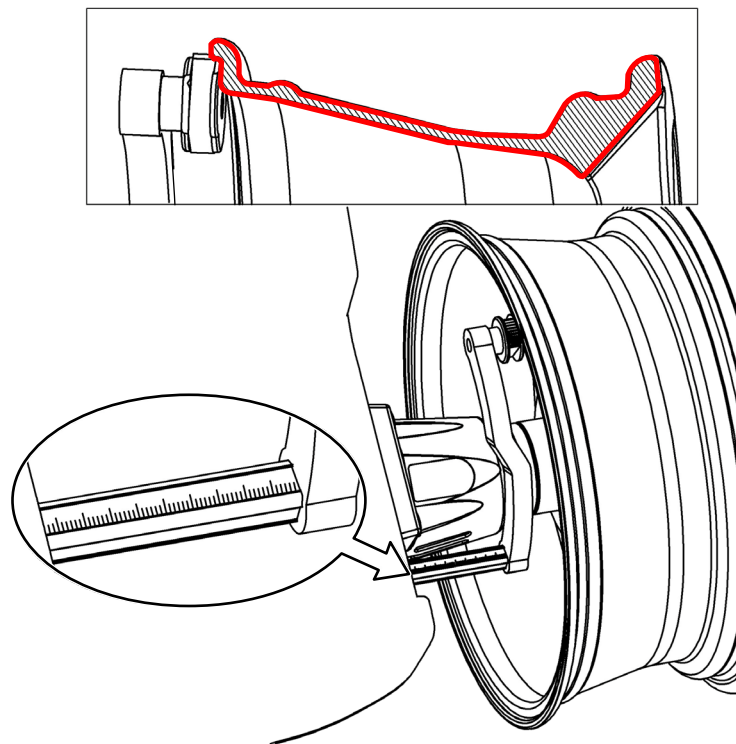

-
- **Diameter.** Read the value from the tire sidewall or measure with the Calipers, then enter that value using the **Diameter +** and **-** buttons on the Control Panel.

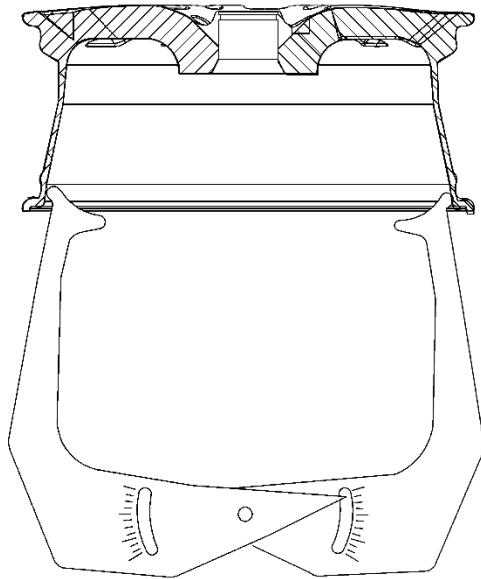

- **Width.** Measure with the Calipers, then enter that value using the Width **+** and **-** buttons on the Control Panel.

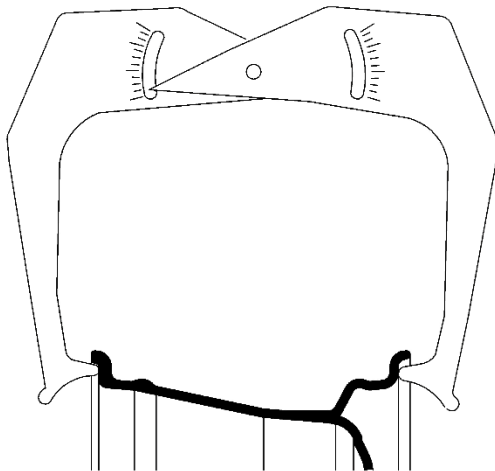

Maintenance

Make sure your Wheel Balancer is maintained on a regular basis.

 **WARNING:** Disconnect the Power Cord from power **before performing any maintenance** and take whatever steps are necessary to make sure the unit cannot be re-energized until Maintenance is over. Because the unit uses electricity, you could be electrocuted or even killed if the unit is powered back on during Maintenance.

To maintain your Wheel Balancer:

- **Daily:** Make sure the unit is clean and dry before using it.
- **Weekly:** Make sure the Shaft Assembly is correctly oriented with the Shaft Housing and is securely tightened.
- **Monthly:** Make sure all Anchor Bolts are tightened and secure.
- **Monthly:** Check all components to make sure they are in good operating condition. If you find a component that is **not** working correctly, take the unit out of service and refer to **Troubleshooting** for more information.
- **Every three months:** Check the bolts on the components attached to the rear of the unit to make sure they are tight and secure.
- **Yearly:** Have an Electrician come out and check the electronic components.
- **Yearly:** Take the unit out of service, disconnect the Power Cord from the power source, and then thoroughly check and clean all components.
- **As required:** Cleaning. Before cleaning remove from power. Do **not** use harsh cleaners or detergents when cleaning plastic components. A damp cloth and a weak solution of water and dish soap are all that is required.

 **WARNING:** Do not operate your Wheel Balancer if you find operation issues; instead, take the unit out of service, then contact your dealer, visit rangerproducts.com/support/, or call **(805) 933-9970**.

Troubleshooting

Perform the following checks if you are experiencing balancing problems:

- Confirm the location and position of the alignment marks on the Shaft Assembly and Shaft Housing (see **Installing the Shaft** for more information).
- Make sure the Balancer is anchored in place (see **Anchoring the Balancer** for more information).
- Perform a Weight Location Verification Test (see **Weight Location Verification Test** for more information).

Perform the calibration with a known-to-be-good steel Wheel of the most used size.

Note: It is a helpful practice to keep on hand a known-good Wheel of a common and basic OE design to use as a calibration / reference tire to assist in troubleshooting.

Make sure the calibration weight used is a 100 gram or 3.5 ounce weight; that is mounted correctly during the calibration procedure.

Issues

Issue	Possible Cause	Action to Take
No display on start-up.	No power Fuse open Power switch fault	Verify power is present. Replace fuse Replace Switch
After start-up, normal display but shaft does not rotate. Humming sound.	Motor Capacitor failure	Replace the 20mF/400V Capacitor
Displays Err 1	Shaft rotates without stopping.	Replace the computer board or encoder board or power board.
Displays Err 2	No wheel on shaft. Main Shaft and adapter are loose. Wheel is incorrectly installed on shaft or not secured correctly. Motor belt is too tight or too loose.	Secure Wheel and run the balancer. Reinstall the Shaft onto the Adapter.
Displays Err 3	Wheel imbalance is too large	Replace the Wheel and test, calibrate balancer, if required.
Display Err 4	Position sensor error	Readjust the position sensor or replace.
Displays Err 5	The Wheel Cover is not down.	Lower the Cover
Displays Err 7	Memory Data loss	Enter the memory values and recalibrate.
Displays Err 8 During Self Calibration	Failed to add 100g weight. Pressure sensor cable is damaged. Computer board failure. Power supply board failure.	Add 100g weight. Check Cable and connections. Replace computer board. Replace Power Supply board.

Issue	Possible Cause	Action to Take
00-00 is displayed	Sensor connection is broken or poor contact. Memory stored value is lost.	Reconnect sensor cable. Re-enter memory values and recalibrate.
Value changes by more than 5g per rotation.	Debris inside the tire or wheel center is deformed. Sensor is wet or the locking nut is not locked. External Power Supply low voltage. Insufficient Tire Pressure The balancer is not anchored	Replace tire Readjust Sensor Stabilize power supply Inflate tire to proper pressure Anchor Balancer.
No braking for more than 10 Seconds	Poor electrical grounding on external power supply. Electrical interference.	Check external Power Supply Shut down and restart balancer.
Inaccurate balance value. Difficult to bring to 00.	Sensor is damaged Program is corrupted.	Replace sensor. Perform Self-Calibration
No braking after displaying imbalance	Damage to the braking system. External electrical interference.	Replace the Power Supply Board Restart the machine.
The test spin results exceed 10g	Irregular rim center hole. Thread or shaft installation error	Replace with new wheel and re-test. Re-install the Shaft on the adapter.
Display indicates hundreds of grams correction	Memory parameter crash Tire imbalance is too big.	Re-enter parameters as per labeling inside of the balancer. Replace the wheel and re-test.
The Outer Arm is not producing correct values on a consistent basis.	Damage to outer arm. Damage to sensor.	Calibrate the Outer Arm. Refer to Calibrating the Outer Arm for more information.
The Inner Arm is not producing correct values on a consistent basis.	Damage to inner arm. Damage to linear or angle encoder	Calibrate the Inner Arm. Refer to Calibrating the Inner Arm for more information.
The lower laser (6 o'clock) does not appear.		The laser has been set to Off or is broken. Enable the bottom laser, then check to see if it is working. If it still does not work, contact BendPak Ranger for instructions.
A 43" tire does not fit on the Balancer.		Remove the Cover, Outer Arm and Outer Arm Mount Bar. Data must be entered manually.

If you continue to have problems with your Wheel Balancer, visit www.bendpak.com/support or call **BendPak Ranger at (805) 933-9970**.

Restoring System Default Parameter Values

Use the following procedure to reset the factory parameter defaults on the Balancer. A label on the inside of the balancer includes the Balancer default parameters.

1. Press and hold the **C** and **T** keys simultaneously. The display will indicate **CAL CAL CAL** and the indicator lights will flash. Release the keys once the indicators stop flashing.
2. In sequence, press the distance key **+**, **-**, and then **ALU** the display will indicate **dF 124**.
3. Set the parameter values. The Outer Display Window indicates the Machine Default value. The Inner Display Window indicates the actual machine value.

Function	Key
Change parameter value	Width Key + -
Move to next parameter	Distance Key +

Parameter	Inner Display	Outer Display	Definition
Grams remaining	rE	05	Set not to display remaining grams
External gauge switch	Aut	on or oFF	Set external gauge on or off
Internal gauge compensation	Da-1	000	Adjust the internal gauge compensation value.
External gauge compensation	Db-1	000	Adjust the external gauge compensation value
Beeper switch	Bee	Off	Beeper switch status
Lower Laser Guide function	LAS	ON	Lower Laser guidance function is on.

System Self-Test

1. Clean the Balancer Shaft and Flange. Mount an undamaged, clean, steel Wheel 15" to 18" on the Balancer Shaft.
2. Press the **T** key. The indicator lights flash one by one from left to right. After the indicator lights are tested the display will show **POS 0**.
3. Slowly rotate the Wheel by hand. The indicators will flash and the right hand display will change from 0 to 127.

NOTE: The values listed below are for reference only. The actual machine value will vary on each machine and wheel. The purpose is to verify that the values change as the wheel rotates.

4. Press the ALU key to display the horizontal reference pressure. **Inn 445**
5. Press the ALU key to display the vertical reference pressure. **OUT 530**
6. Press the ALU key to display the distance potentiometer reference value. **dis 40**
7. Press the ALU key to display the diameter potentiometer reference value. **dia 235**
8. Press the ALU key to display the width potentiometer reference value. **lar 0**

System Self Calibration

The Dual-Plane Self-Calibration Procedure ensures the Balancer is producing accurate readings by aligning the software with the existing spindle positions and hardware on the Balancer. Replacement of the computer board or the pressure sensor requires running this procedure.

Before performing the Self-Calibration Procedure, verify the Balancer is anchored to the floor and that the shaft and centering cones or collets are clean and undamaged. Dirt or damage can cause inaccurate readings.

Important: Pay close attention to this procedure. If not done correctly, the Balancer will not produce accurate readings, leading to Wheels not being balanced correctly.

Important: A clean, steel, undamaged Wheel 15" to 18" is required for this procedure. Do **not** use a Trailer Wheel to perform this calibration. Trailer Wheels are too narrow.

1. Mount a steel wheel on the Balancer Spindle.
2. Press and hold the **C** key and press the **T** key at the same time. The display panel should display CAL CAL CAL and the indicator lights will all flash. Release the keys after all the indicators stay in the on condition.
3. Press the **START** key to start the measurement. The display should read **100** and **ADD**.
4. Add a clip-on 100g weight to the inner rim of the wheel.
5. Press the **START** key to begin the measurement. The display should read **ADD** and **100**.
6. Add a clip on 100g weight to the outer rim of the wheel.
7. Press the **START** key to begin the measurement. The display should now read **END** and **CAL**.
8. Press **START** key to begin the measurement and verify the results.

System Self Calibration Results:

Display Reads	00 and 100 ±4g allowed discrepancy.
Weight Position	The Inner and Outer indicators are all lit, the 100g weight is directly below the shaft and a discrepancy of ±4° is allowed.

Calibrating the Inner Arm

Perform this procedure **without** a Wheel mounted.

1. The Shaft Flange and Inner Ruler should be clean.
2. Verify the Inner Arm is in the home "0" position.
3. Pull out the Inner Ruler to 100mm and hold it there while pushing **ALU**.
4. **CAL** and **100** should appear on the display.
5. Pull the ruler out to 235mm and hold it there. Rest the head against the shaft flange, then press **ALU**.
6. **CAL 15.0** should appear on the display.

Inner Arm Calibration Results:

Display Reads	000 000 000 Indicates calibration successful.
Display Reads	CAL and 100 Indicates recalibration is required.

Calibrating the Outer Arm Sonar

The Outer Arm Sonar Calibration verifies the Outer Arm Sonar is returning correct measurement values.

Note: The Balancer is delivered from the factory in a calibrated condition. Only perform this calibration if you are encountering multiple incorrect Wheel balances or have replaced Sonar components.

Perform this procedure **without** a Wheel mounted.

To calibrate the Outer Arm:

1. Close the Cover.
2. Press and hold the **C** key then add the **T** key. **CAL CAL CAL** appears on the display and the placement indicators flash. Release the buttons when the indicators stop flashing.
3. In sequence, press the **Distance -**, **+**, and **ALU** keys.
4. Press the Distance **+** or **-** keys to adjust the value up and down to **db -1 380**

Changing the Setting of the Lower Laser

 **WARNING** Do **not** look directly into the laser. Doing so may damage your eyes.

To Enable and Disable the Lower Laser:

1. Press **C** and **T** to enter the Parameter Program.
2. Press the **Distance +** key then the **-** key and finally the **ALU** key to access the Balancer settings.
3. Press the **Distance +** key five times to access the Lower Laser Function. The Leftmost display will read **LAS** and the right display will read **OFF**.
4. Press the **Width +** key to enable the Lower Laser. The rightmost window will now display **ON**. The Lower Laser is now enabled.
5. To disable the Lower Laser Function, repeat the steps above but change the Lower Laser status in step 4 to Off.

If the Lower Laser still does not appear, contact Ranger Support by visiting www.bendpak.com/support or call **BendPak Ranger at (805) 933-9970** for assistance.

Adjust the Belt Tension

The Motor Drive Belt may loosen over time.

To tighten the belt:

1. Disconnect the Balancer from Power. If your facility has lockout/tagout procedures implement them to verify power cannot be supplied to the Balancer while adjusting the belt tension.
2. Remove the Weight Tray.
3. Loosen the Bolts securing the Motor.
4. Move the Motor back to increase the tension and secure. The belt correctly tensioned should deflect about 4mm when pressed downward.

LS45DS Wheel Balancer Disposal - End of Service Life

Once LS45DS has reached the end of its service life it must be disposed of properly. Disconnect the Balancer from power and disassemble. Classify the components by material and dispose of in accordance with national and local regulations. Electronic circuit boards and electrical components are to be delivered to an electronic recycling facility.

Metal recyclers will be able to advise on recycling the Balancer's metal components and will *reuse* the materials, diverting them from landfills.

If you are unable to find an appropriate facility, the website earth911.com has resources that may be of help.

Wiring Diagram

220 VAC, 3A, 50/60 Hz, 1 Ph, 0.55kW

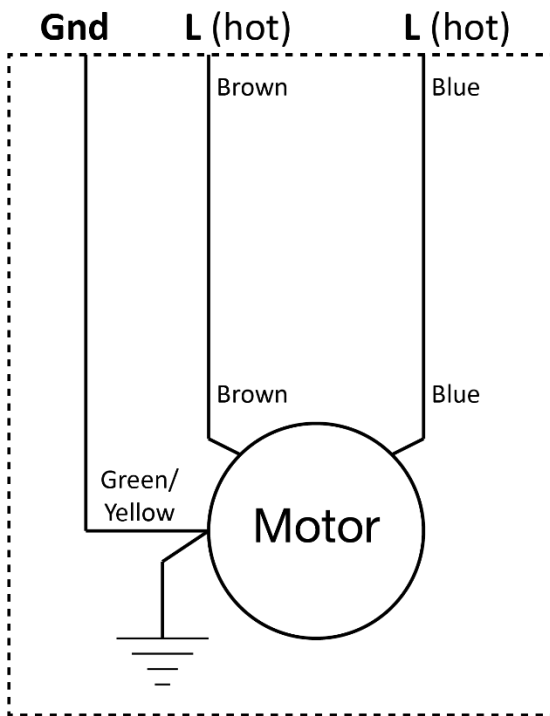

Labels

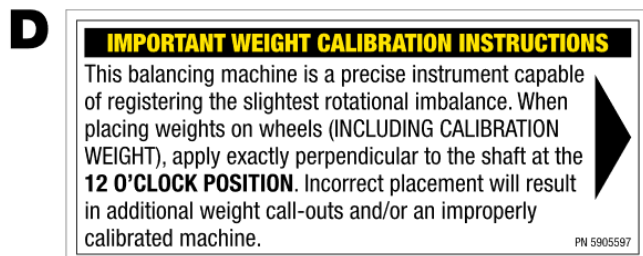
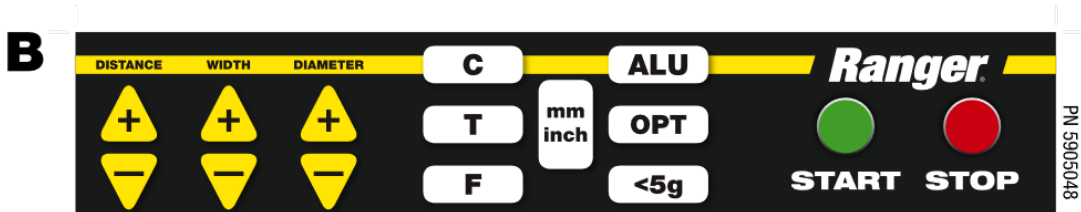
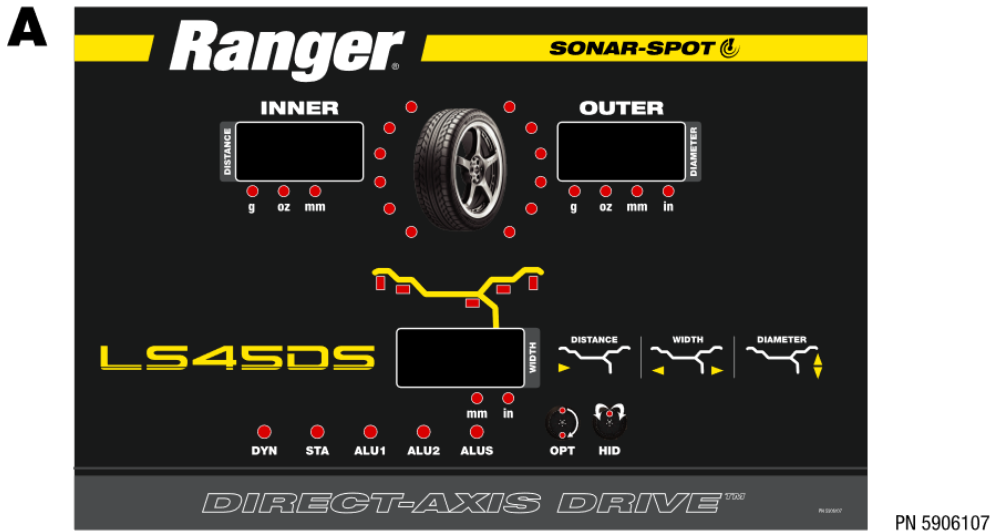

PN 5905597



PN 5905050



PN 5906096



Parts

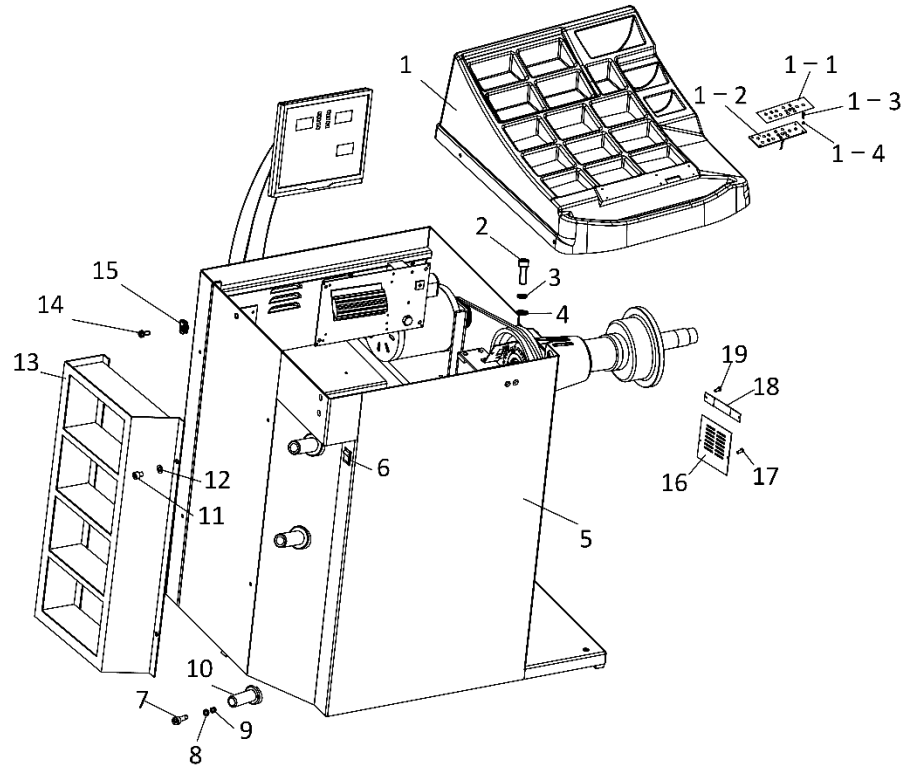

Cabinet Assy.

#	Part Number	Description
1	5328420	Weight Tray
1-1	5328422	Keyboard Cover
1-2		Keyboard Plate
1-3		Cross Recessed Flat Head Screw
1-4		Nut, M3
2	5530304	Hex Socket Head Screws M8 x 20
3	5530104	Washer Φ 8 Spring
4	5402104	Washer Φ 8 Flat
5		Storage Cover
6	5525251	Rocker Switch
7	5400959	Hexagon socket head screws M6 x 30
8	5400913	Washer Φ 6 Flat
9		Hexagon Nut M6
10	5327132	Tool Shanking
11		Hexagon Head Bolt Full Thread M8 x 20
12		Washer Φ 8 Flat
13	5327993	Slide Storage Cover
14		Hexagon Socket Head Flange Screw M6 x 20
15		B Type Reed Nut M6
16		Baffle
17		Spring Washer Tail Screw ST 5. 5 x 25
18		Baffle Plate Weldment
19		Cross Slotted Large Flat Head Screw (Black) M4 x 8

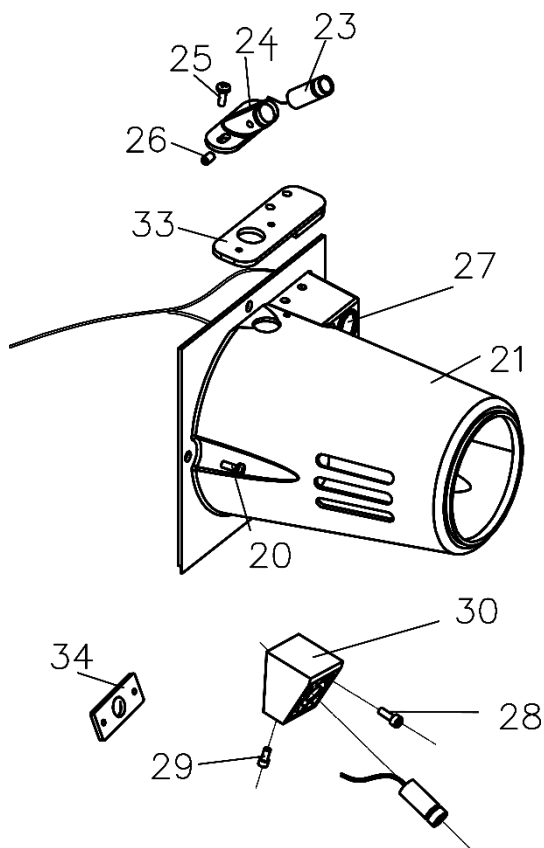

Upper and Lower Laser Assy.

#	Part Number	Description
20		Cross Recessed Pan Head Screw M4 x 12
21		Thread Shaft Plastic Cover
23	5328483	One Font Laser Light Source
24		Laser Chassis
25		Cross Recessed Pan Head Screw M4 x 12
26	5327505	Inner Hexagon End Set Screw M5 x 5
27	5328009	Lower Laser Light Assembly
28		SHCS M4 x 20
29		Hexagon Socket Set Screw with Flat Point M4 x 4
30		Laser Stents
33		Laser Plate

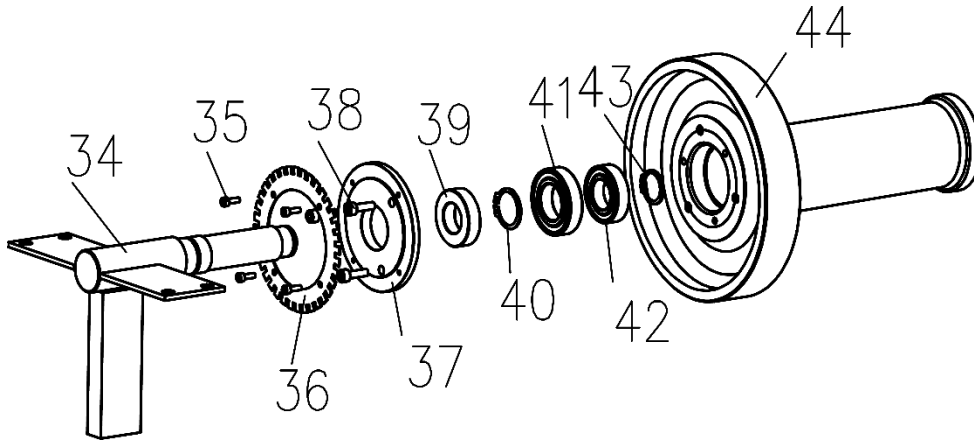

Main Shaft Assy.

#	Part Number	Description
34		Deformation of Beams
35		SHCS M4 x 12
36	5328261	Tooth 64
37		Bearing Cover
38	5400957	SHCS M6 x 20
39		Round Nut
40		Snap Ring 30 mm
41		Bearing 6006
42		Bearing 6005
43	5327179	Snap Ring 25 mm
44		Axle Sleeve Assembly

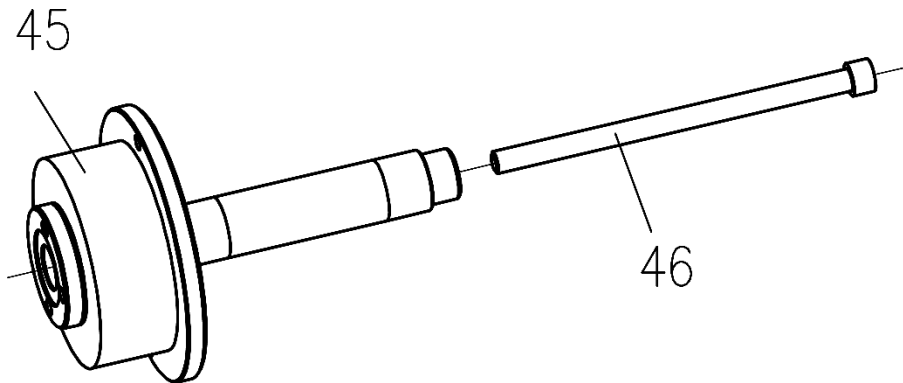

Adapter Assy.

#	Part Number	Description
45	5328538	DST2420 Threaded Shaft/ Spindle, 40mm / Ø40X4mm-310mm / Wheel Balancer. Fits DST30P, LS45DS, DST64T
46	5530469	Socket Head Cap Screw - M14 x 2.0 x 280mm

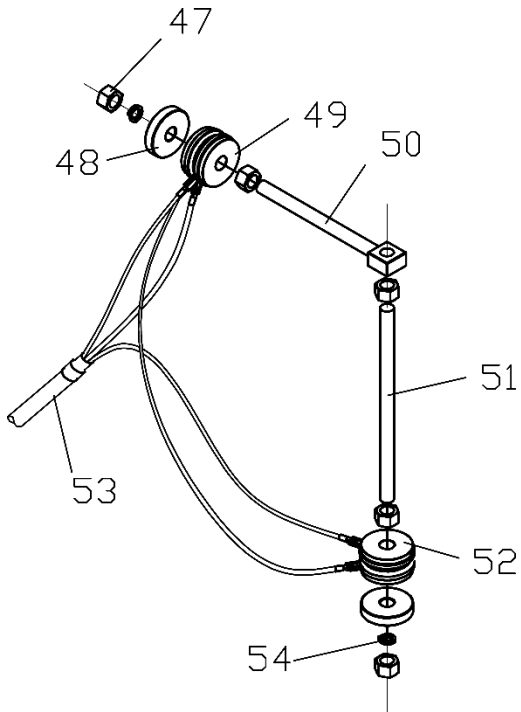

Sensor Assy.

#	Part Number	Description
47	5400457	Hex Nut M10
48		Piezo Sensor Pad
49		Sensor (Horizontal)
52	5327141	Sensor (Vertical)
53		Sensor Wire
50	5327140	Piezo Horizontal Shaft
51	5327139	Piezo Vertical Shaft
54		Washer

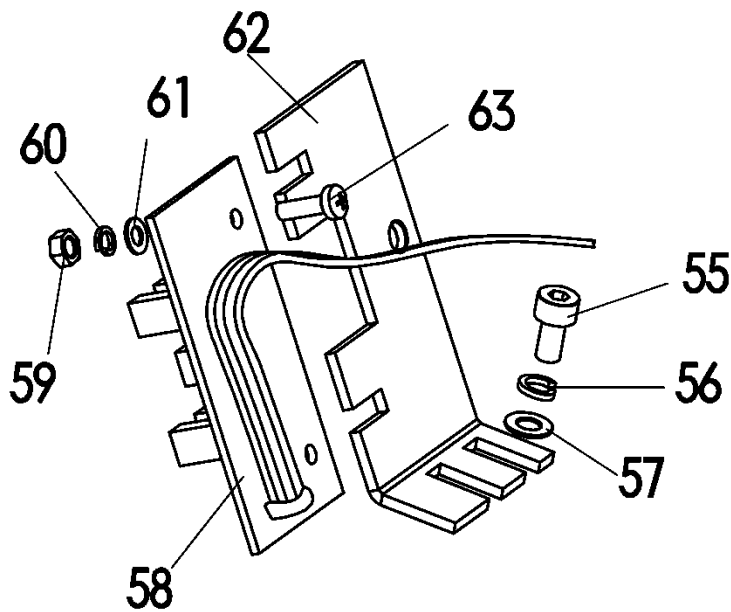

Touch Photovoltaic Panel

#	Part Number	Description
55	5327870	SHCS M4 x 8
56		Spring Pad
57		Plain Washer
58	5328011	Photovoltaic Panels
59		Hex Nut M3
60		Spring Pad
61		Washer
62	5327686	Encoder Bracket
63		Cross Recessed Pan Head Screw M3 x 10mm

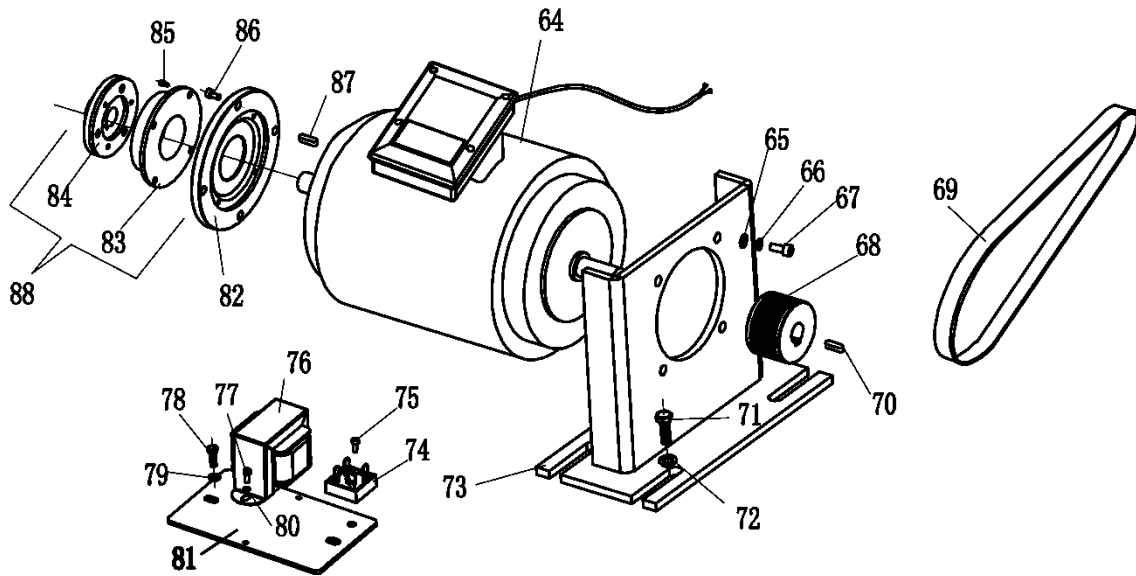

Motor Assy.

#	Part Number	Description
64	5328448	Electromagnetic Brake Motor
65	5400913	Plain Washer
66	5327793	Spring Pad
67	5327730	SHCS M6 x 16
68	5327144	Small Belt Pulley
69	5327091	Motor Belt
70	5327145	Motor Pulley Key 5 x 5 x 30
71		Hexagon Head Bolt Full Thread
72		Big Washer
73		Motor Cabinet
74	5328414	Rectifier
75		Cross Recessed Pan Head Screw
76	5328418	Transformer Balancer
77		Cross Recessed Pan Head Screw
78		HHB
79	5400913	Plain Washer $\phi 6$
80		Plain Washer $\phi 4$
81		Transformer base
82		Brake Mounting Plate
83		Electromagnetic Brake Assembly
84		Friction Disk
85		SHCS M4 x 10
86		SHCS M6 x 20
87		Motor Pulley Key 5 x 5 x 20
88	5328410	Dry Disc Electromagnetic Brake

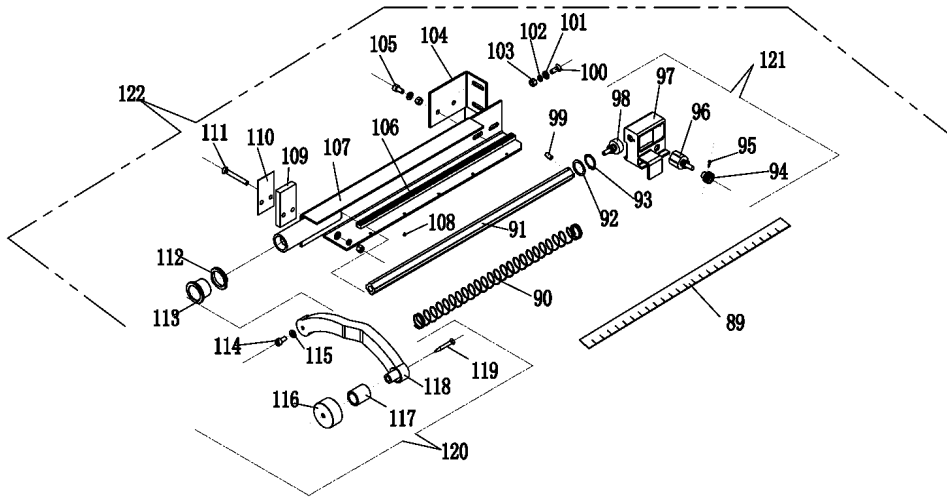

Inner Distance Arm Assy.

#	Part Number	Description
89	5327591	Distance Arm Sticker
90	5328023	Distance Arm Spring
91		Distance Arm Rod
92		Distance Arm Rod Washer
93		Snap Ring 20
94	5328022	Distance Arm Gear
95		FHPS
96	5328021	Wheel Distance Potentiometer
97	5328020	Distance Arm Slide Block
98	5328019	Wheel Diameter Potentiometer
99		Hexagon Socket Set Screw with Flat Point M4 x 4
100	5327889	Cross Recessed Pan Head Screw M6 x 20
101	5400913	Washer 6 mm Flat
102		Washer 6 mm Split Lock
103		Hex Nut
104	5327730	Distance Arm Angle Plate
105	5328018	SHCS M6 x 16
106		Distance Arm Sticker
107		Distance Arm Basement
108		Cross Recessed Tapping Screw
109		Internal Pad
110		Distance Arm Spacer Shim
111	5328017	Cross Recessed Pan Head Screw
112	5328016	Distance Arm Nut
113	5327730	Distance Arm Nut Sleeve
114	5400913	SHCS M6 x 10
115	5327089	Washer 6 mm Flat
116		Caput Ulnare
117		Caput Ulnare Cover
118	5328025	Distance Arm Caput Bend Rod
119		Cross Recessed Pan Head Screw
120	5328409	Distance Arm Assembly
121		Distance Arm Slide Block Assembly
122		Inner Distance Arm Assembly

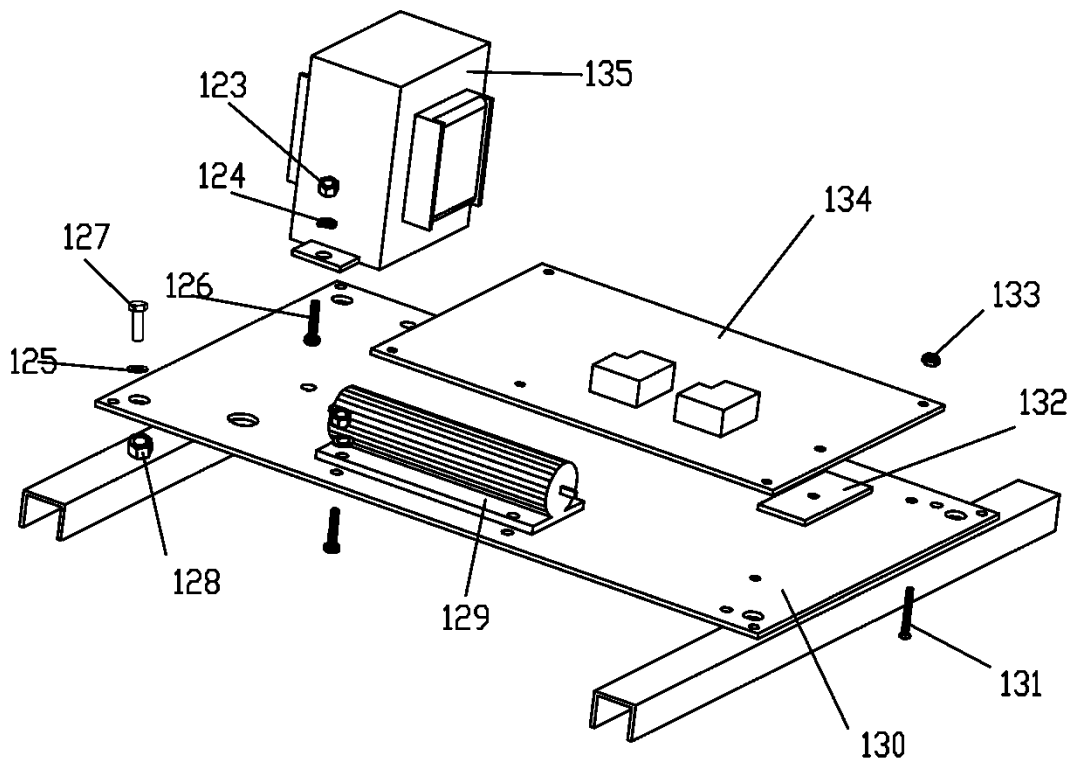

Power Panel Assy.

#	Part Number	Description
123		Nut M4
124		Washer 4 mm Split Lock
125		Washer 6 mm Split Lock
126		Cross Recessed Pan Head Screw M4 x 16
127		HHB M6 x 16
128		Nut M8
129	5327148	Resistor
130		Electrical Mounting Plate
131		Cross Recessed Pan Head Screw M3 x 25
132		Thermal Slug
133		Nut M3
134	5328413	Power Board
135		Transformer

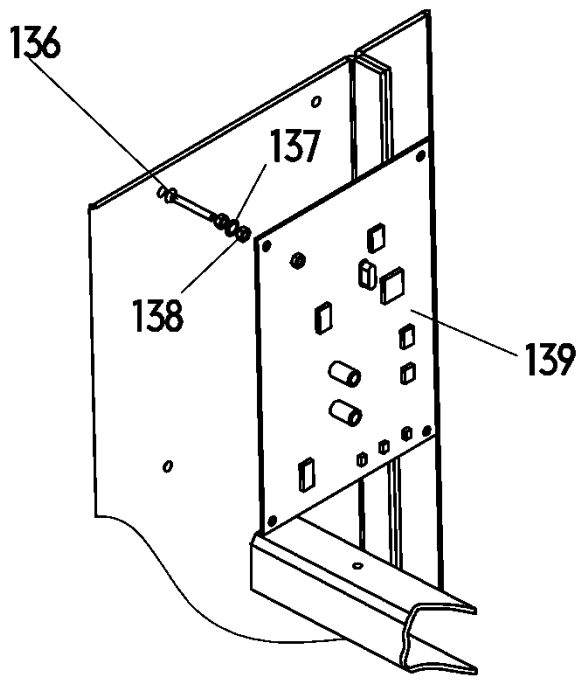

Computer Board Assy.

#	Part Number	Description
136		Cross Recessed Pan Head Screw M3 x 25
137		Washer 3 mm Split Lock
138		Nut M3
139	5328402	Computer Board

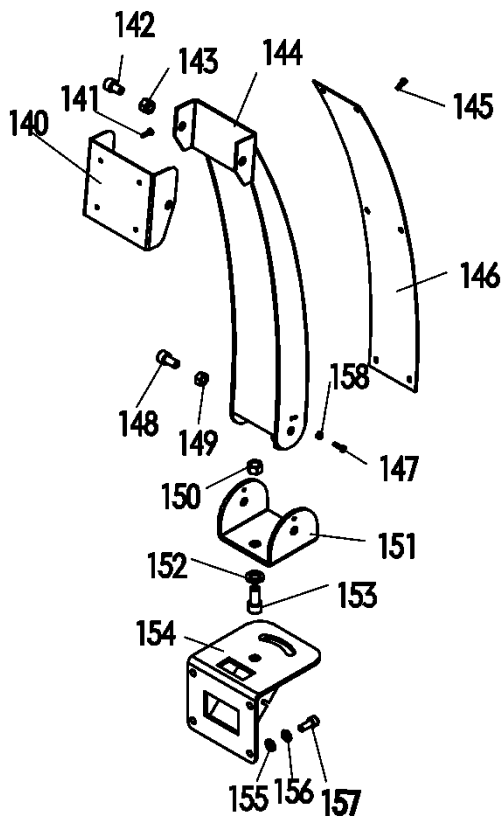

Display Support Assy.

#	Part Number	Description
140		Display Mounting Plate
141		Cross Recessed Pan Head Screw M4 x 16
142		SHCS M10 x 20
143		Non-Metal Insert Self-Locking Nut
144		Display Support
145		SHCS M4 x 12
146		Back Shroud
147		SHCS M4 x 20
148		SHCS M10 x 20
149	5328423	Non-Metal Insert Hexagonal Lock Nut
150		Non-Metal Insert Hexagonal Lock Nut
151		U Channel Display Support
152		Washer; 12 mm Flat
153		SHCS M12 x 30
154		Joint Block Welding
155		Washer 8 mm Flat
156		Washer 8 mm Lock
157		SHCS M8 x 20
158		Nut M4

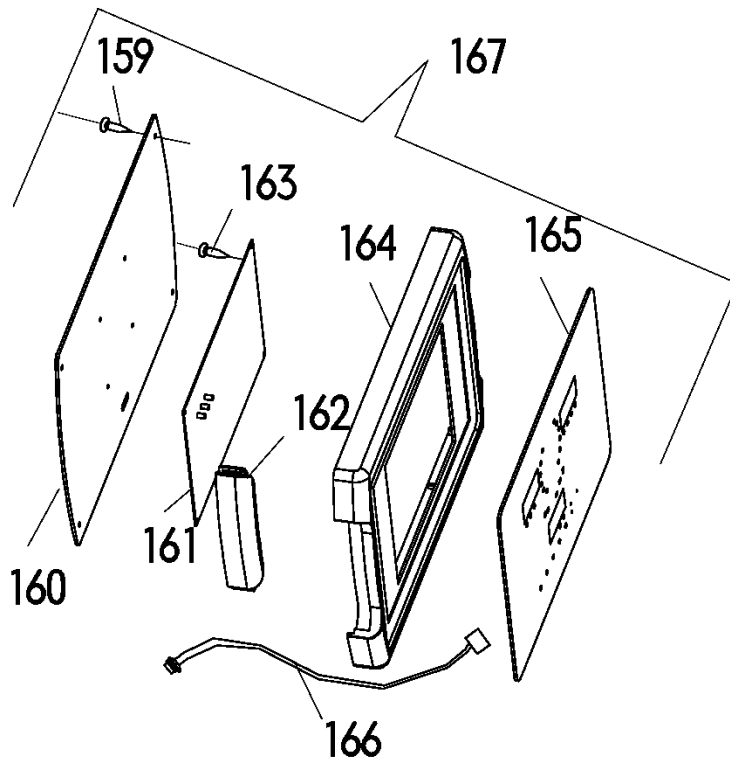

Display Support Assy.

#	Part Number	Description
159		SHCS M4 x 8
160	5328403	Display Baseplate
161	5328404	Display Board
162	5328516	Display Board Cover
163		Cross Slotted Half-Round Head Self-Tapping Screw
164	5328405	Display Board Mask
165	5328406	Display Cover
166	5328412	Display Board Top Harness
167		Display Support Assembly

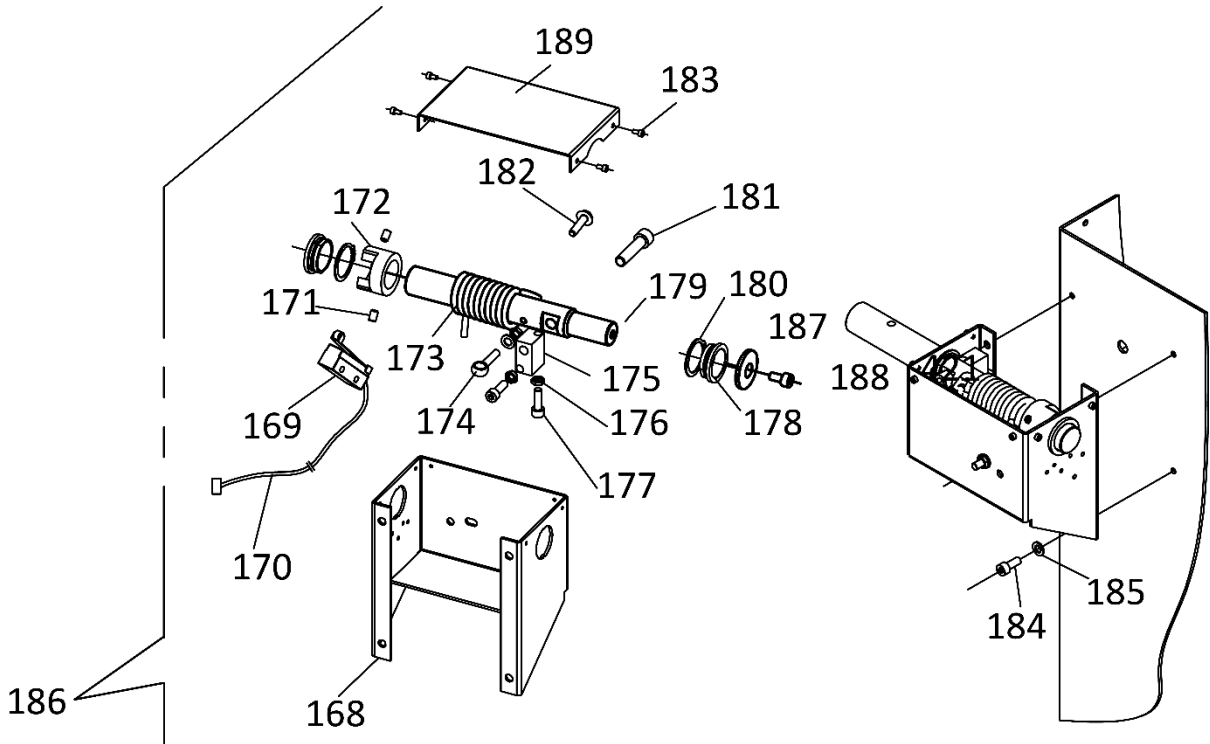

Wheel Cover Mounting Assy.

#	Part Number	Description
168	5328012	Wheel Cover Mounting Assembly Bracket
169	5327932	Wheel Cover Switch
170		Short Wheel Cover Switch Wires
171		Hexagon Socket Set Screw with Flat Point M8 x 12
172		Wheel Cover Cam
173	5327168	Wheel Cover Spring
174	5327180	Adjustable Eye Bolt
175		Wheel Cover Cam Stop
176		Nut M8
177		SHCS M8 x 25
178	5327167	Wheel Cover Shaft Bushing
179		Wheel Cover Rotating Shaft
180		Snap Ring 38 mm
181		SHCS M12 x 40
182		Hexagon Flange Face Bolt
183		SHCS M4 x 8
184		SHCS M8 x 20
185		Washer 8 mm Flat
186	5328014	Wheel Cover Mounting Assembly
187		Washer 8 mm
188		SHCS M10 x 16
189	5327164	Wheel Cover Mounting Assembly Upper Cover

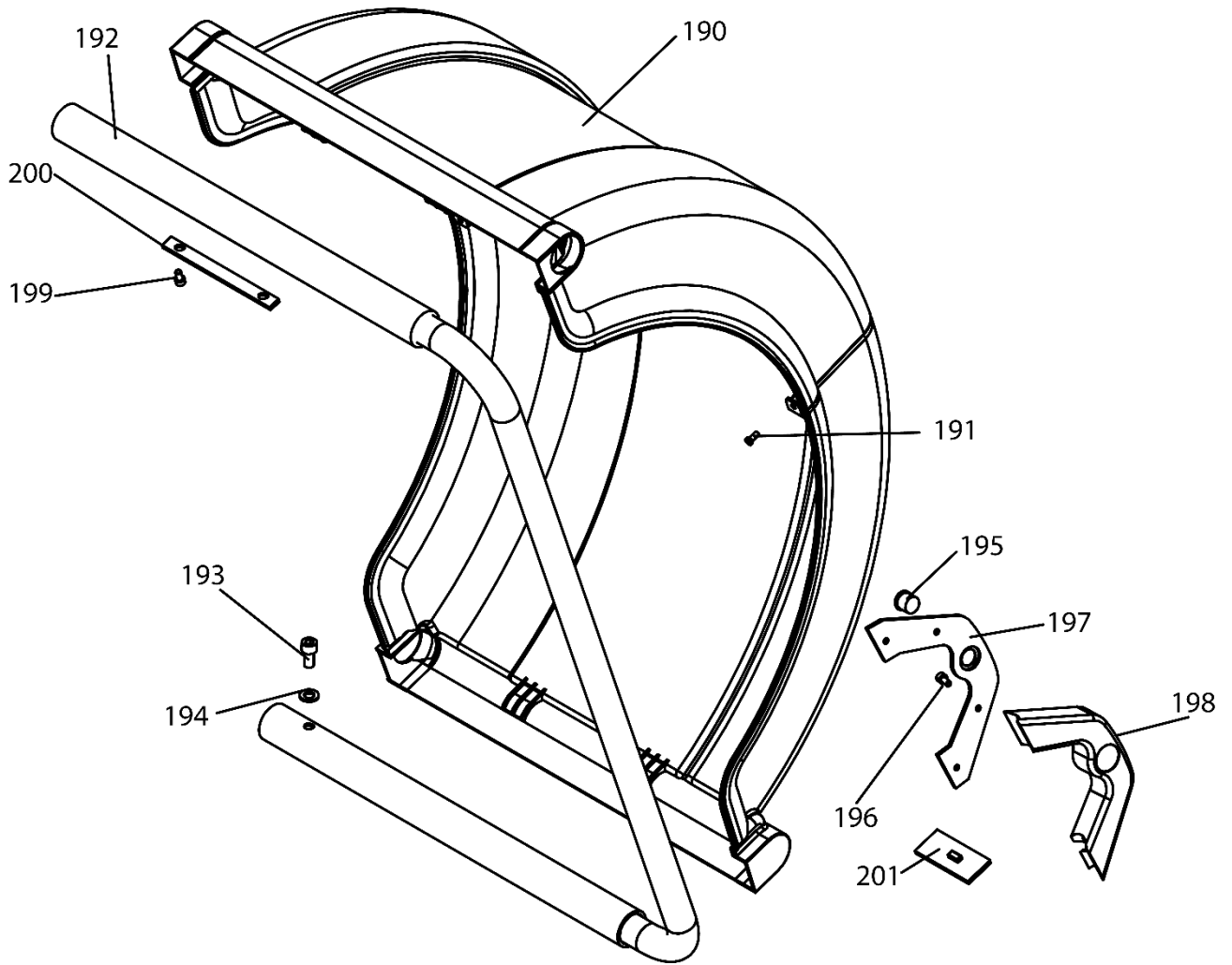

Tire Cover Assy.

#	Part Number	Description
190		Cover
191		Cross Recessed Pan Head Screw M5X12
192		Shield bracket
193		Hexagon Socket Cap Screws M10X20
194		Flat washer Ø10
195		Sonar
196		Hexagon Socket Cap Screws M6X16
197		Sonar Plate
198		Sonar Hood
199		Cross recess pan head screw M4X12
200		Cover Lock
201		Sonar Circuit Board

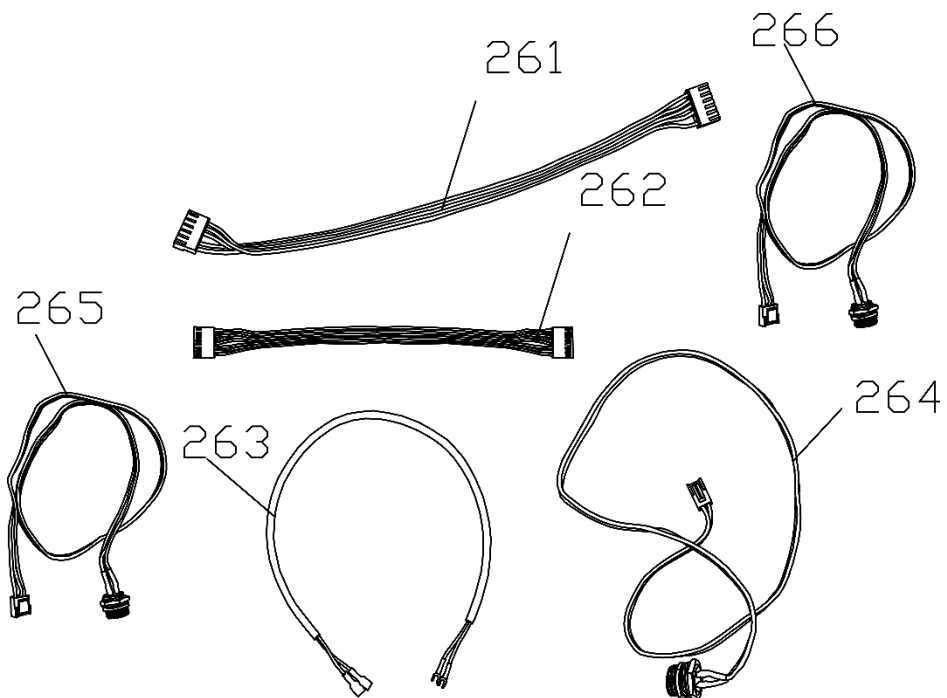

Wiring Assy.

#	Part Number	Description
261		Connecting Wire
262		Keyboard Wire
263		Switch Wire
264		Cover Wire
265		Sonar Connection Wire
266		Display Board Wire

LS45DS Accessories Parts List

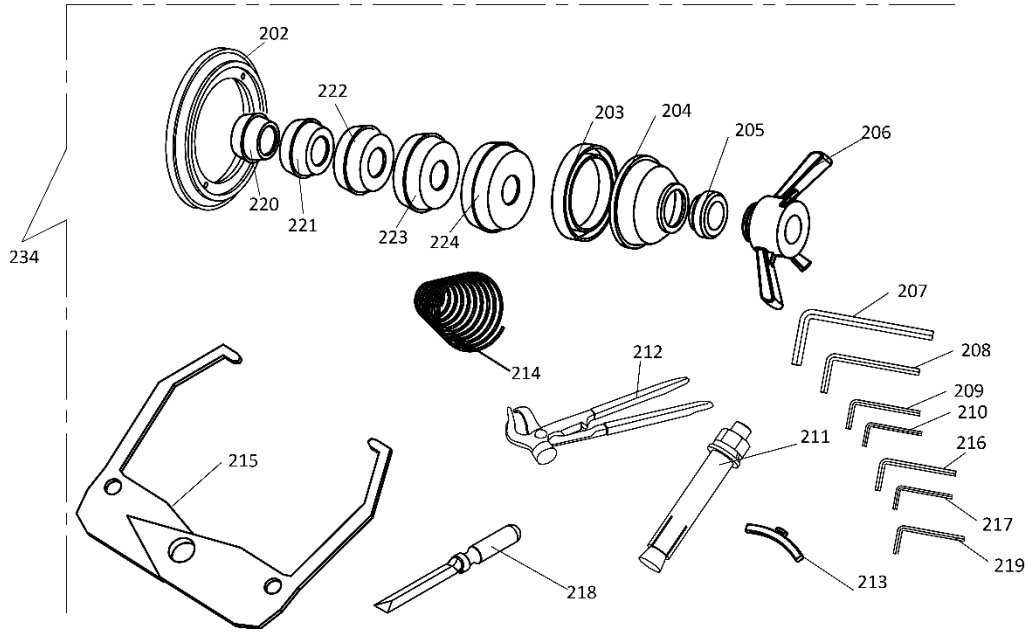

#	Part Number	Description
202	5327063	Spacer Ring
203	5327074	Quick Nut Cup Cover
204	5327061	Quick Nut Cup
205	5327172	Quick Nut Cover
206	5328537	Quick Nut; 36mm
207	5327720	Allen Wrench; 12mm
208	5328055	Allen Wrench; 6mm
209	5328056	Allen Wrench; 4mm
210	5328057	Allen Wrench; 3mm
211	5327100	Anchor Bolt; M10X59
212	5346425	Weight Hammer Pliers
213	5346879	Calibration Weight
214	5328536	Mounting Spring; 40mm
215	5402187	Wheel Width Caliper
216		Allen Wrench; 8mm
217		Allen Wrench; 5mm
218		Weight Removal Tool
219	5400002	Allen Wrench
220		52-70mm Collet; (40mm)-Accessory Box
221	5328128	66-83mm Collet; (40mm)-Accessory Box
222	5328068	80-97mm Collet; (40mm)-Accessory Box
223	5328286	94-111mm Collet; (40mm)-Accessory Box
224	5328571	110-127mm Collet; (40mm)-Accessory Box
234	5328572	Accessory Box

Lug-Centric Pressure Plate

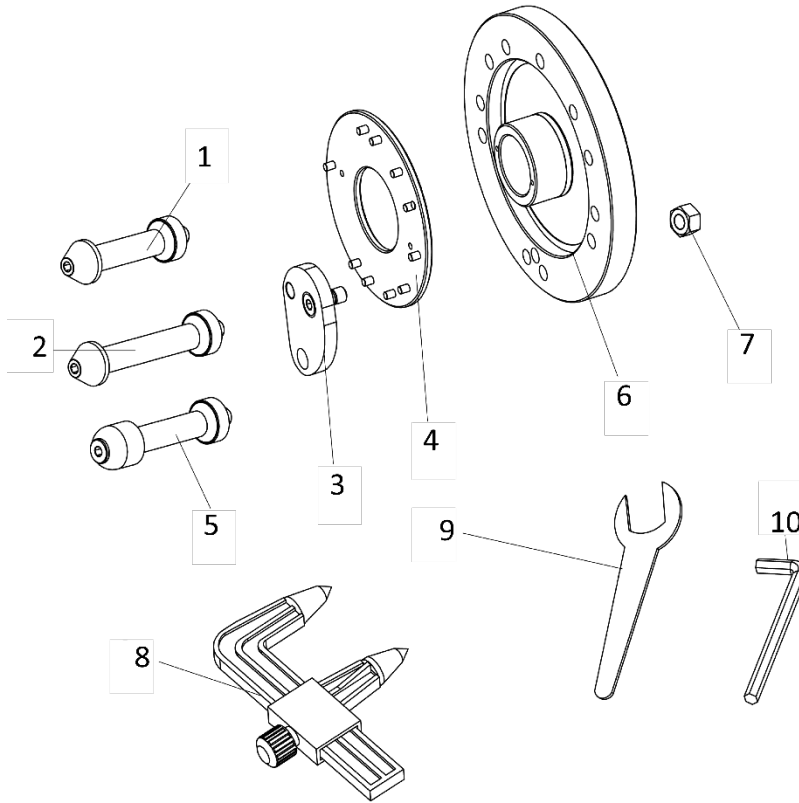

#	Part Number	Description
	5328635	Lug-Centric Pressure Plate Assembly
1		Lock Nut 92 (Lug Pin)
2		Lock Nut 114 (Lug Pin)
3		Moving Piece
4		Turntable
5		Lock Nut 101 (Lug Pin)
6		Market Component (40mm Spindle)
7		Cap Nut
8		Caliper, Plastic
9		Wrench, Open End 17mm
10		Wrench, Allen 5mm

Ranger[®]

30440 Agoura Road
Agoura Hills, CA 91301 USA
[bendpak.com](https://www.bendpak.com)