

ROTARY POSITIONER SETUP INSTRUCTIONS



Applicable to BuildPro® / Siegmund® Tabletops



Thank you for choosing the BuildPro® Rotary Positioner.
Please read all setup instructions before beginning the setup process.

WARRANTY

Each Strong Hand tool is warranted to be free from defects in material and workmanship. Return the tool to place of purchase for a replacement if warranty applies.

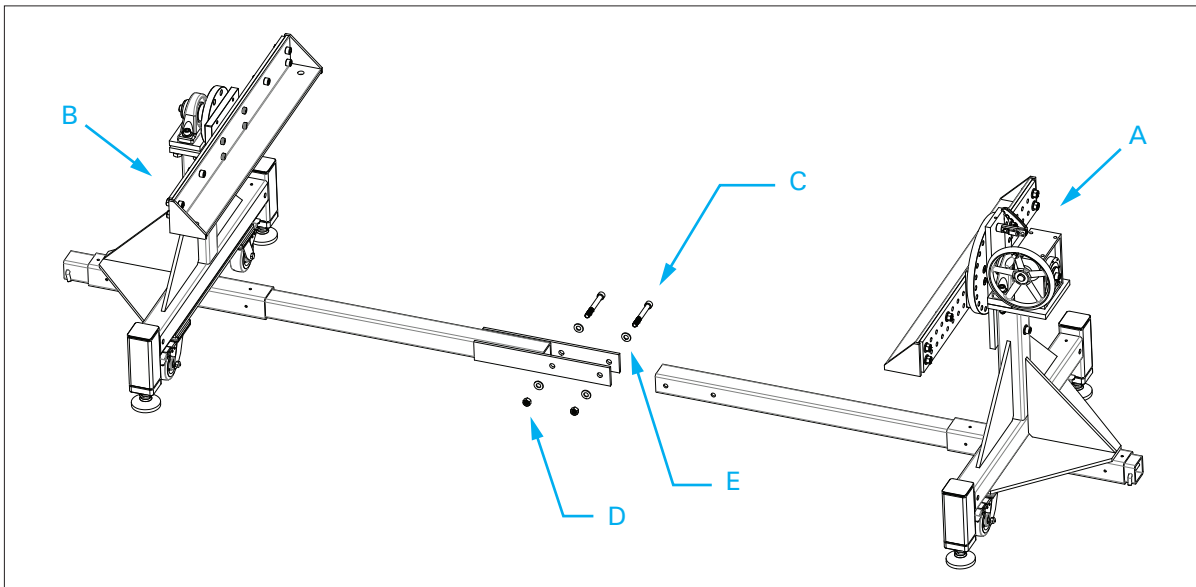

- | | |
|--------------------------------------|---|
| A. HEAD STOCK ASSEMBLY | 1 |
| B. TAIL STOCK ASSEMBLY | 1 |
| C. 5/8-11 X 5" SOCKET HEAD CAP SCREW | 2 |
| D. 5/8-11 HEX NUT | 2 |
| E. 5/8 WASHER | 4 |

Step 1 – Join the two expandable adjustment bars using hardware provided to create the expanding base of the Positioner.

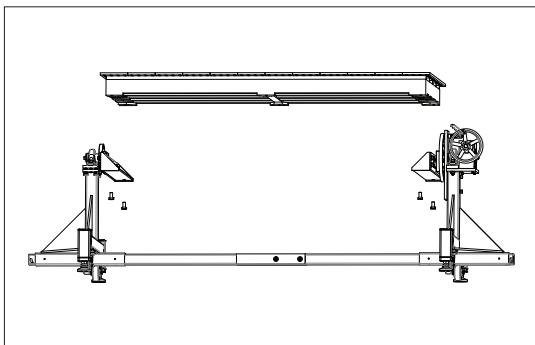

Step 2 – Properly seat your welding tabletop in the two table mounting brackets. Lock securely into position using hardware provided.

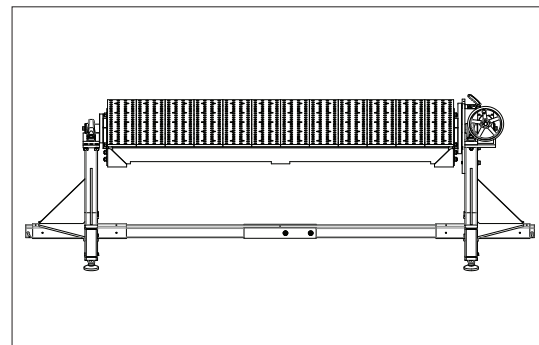

Your Rotary Positioner is now ready for use.

© Copyright 2017. All Rights Reserved.