



Operating Instructions and Parts Manual 20" EVS Drill Press with Powerfeed

Models: JDP20EVST-230-PDF, -460-PDF



JET
427 New Sanford Road
LaVergne, Tennessee 37086
Ph.: 800-274-6848
www.jettools.com

Part No. M-354245
Edition 1 10/2016
Copyright © 2016 JET



1.0 IMPORTANT SAFETY INSTRUCTIONS

- Misuse of this machine can cause serious injury.
- For safety, machine must be set up, used and serviced properly.
- Read, understand and follow instructions in the Operating Instructions and Parts Manual which was shipped with your machine.

When setting up machine:

- Always avoid using machine in damp or poorly lighted work areas.
- Always be sure the machine support is securely anchored to the floor or the work bench.

When using machine:

- Always wear safety glasses with side shields (See ANSI Z87.1)
- Never wear loose clothing or jewelry.
- Never overreach—you may slip and fall.

When servicing machine:

- Always disconnect the machine from its electrical supply while servicing.
- Always follow instructions in Operating Instructions and Parts Manual when changing accessory tools or parts.
- Never modify the machine without consulting JET.

You—the stationary power tool user—hold the key to safety.

Read and follow these simple rules for best results and full benefits from your machine. Used properly, JET machinery is among the best in design and safety. However, any machine used improperly can be rendered inefficient and unsafe. It is absolutely mandatory that those who use our products be properly trained in how to use them correctly. They should read and understand the Operating Instructions and Parts Manual as well as all labels affixed to the machine. Failure to follow all of these warnings can cause serious injuries.

1.1 Machinery general safety warnings

1. Always wear protective eye wear when operating machinery. Eye wear shall be impact resistant, protective safety glasses with side shields which comply with ANSI Z87.1 specifications. Use of eye wear which does not comply with ANSI Z87.1 specifications could result in severe injury from breakage of eye protection.
2. Wear proper apparel. No loose clothing or jewelry which can get caught in moving parts. Rubber soled footwear is recommended for best footing.
3. Do not overreach. Failure to maintain proper working position can cause you to fall into the machine or cause your clothing to get caught, pulling you into the machine.
4. Keep guards in place and in proper working order. Do not operate the machine with guards removed.
5. Avoid dangerous working environments. Do not use stationary machine tools in wet or damp locations. Keep work areas clean and well lit.
6. Avoid accidental starts by being sure the start switch is "OFF" before plugging in the machine.
7. Never leave the machine running while unattended. Machine shall be shut off whenever it is not in operation.
8. Disconnect electrical power before servicing. Whenever changing accessories or general maintenance is done on the machine, electrical power to the machine must be disconnected before work is done.
9. Maintain all machine tools with care. Follow all maintenance instructions for lubricating and the changing of accessories. No attempt shall be made to modify or have makeshift repairs done to the machine. This not only voids the warranty but also renders the machine unsafe.
10. Machinery must be anchored to the floor.
11. Secure work. Use clamps or a vise to hold work, when practical. It is safer than using your hands and it frees both hands to operate the machine.
12. Never brush away chips while the machine is in operation.
13. Keep work area clean. Cluttered areas invite accidents.
14. Remove adjusting keys and wrenches before turning machine on.

15. Use the right tool. Don't force a tool or attachment to do a job for which it was not designed.
16. Use only recommended accessories and follow manufacturer's instructions pertaining to them.
17. Keep hands in sight and clear of all moving parts and cutting surfaces.
18. All visitors should be kept at a safe distance from the work area. Make workshop completely safe by using padlocks, master switches, or by removing starter keys.
19. Know the tool you are using — its application, limitations, and potential hazards.
20. **CALIFORNIA PROPOSITION 65 WARNING:** This product contains chemicals known to the State of California to cause cancer, or birth defects or other reproductive harm.
21. This product, when used for welding, cutting, or working with metal, produces fumes, gases, or dusts which contain chemicals known to the State of California to cause birth defects and, in some cases, cancer. (California Health and Safety Code Section 25249.5 et seq.)

Familiarize yourself with the following safety notices used in this manual:

CAUTION This means that if precautions are not heeded, it may result in minor injury and/or possible machine damage.

WARNING This means that if precautions are not heeded, it may result in serious or even fatal injury.

1.2 General electrical cautions

This drill press should be grounded in accordance with the National Electrical Code and local codes and ordinances. This work should be done by a qualified electrician. The saw must be grounded to protect the user from electrical shock.

Wire sizes

Caution: For circuits which are far away from the electrical service box, the wire size must be increased in order to deliver ample voltage to the motor. To minimize power losses and to prevent motor overheating and burnout, the use of wire sizes for branch circuits or electrical extension cords according to Table 1 (sect. 6.3) is recommended.

1.3 Safety instructions for drill presses

1. All work shall be secured using either clamps or a vise to the drill press table. It is unsafe to use your hands to hold any workpiece being drilled.
2. Drill press head and table shall be securely locked to the column before operating the drill press. This must always be checked prior to starting the machine.
3. Always use the correct tooling. Tooling shall always be maintained and properly sharpened. All tooling must be run at the proper speeds and feeds as they apply to the job. Use only recommended accessories and follow those manufacturer's instructions pertaining to them. Tooling shall not be forced in to any work piece but fed according to the proper specifications. Failure to follow these instructions will not only ruin the tooling as well as the machine, but can cause serious injury.
4. Never brush away any chips while the machine is in operation. All clean up should be done when the machine is stopped.
5. Keep hands in sight. Do not put hands or fingers around, on, or below any rotating cutting tools.
6. Leather safety gloves should be used when handling any sharp objects or cutting tools. See A, Figure 1-1.
7. Always wear protective eye wear when operating, servicing or adjusting machinery. Eyewear shall be impact resistant, protective safety glasses with side shields complying with ANSI Z87.1 specifications. Use of eye wear which does not comply with ANSI Z87.1 specifications could result in severe injury from breakage of eye protection. B, Figure 1-1.
8. When drilling in material which causes dust, a dust mask shall be worn. See C, Figure 1-1.
9. Avoid contact with coolant, especially guarding the eyes.
10. Non-slip footwear and safety shoes are recommended. See D, Figure 1-1.
11. Wear ear protectors (plugs or muffs) during extended periods of operation. See E, Figure 1-1.

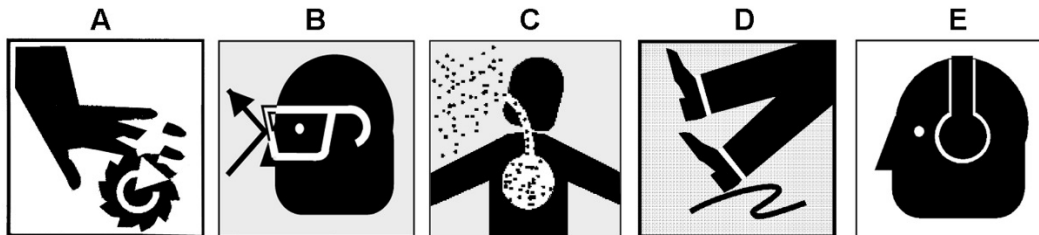

Figure 1-1

SAVE THESE INSTRUCTIONS

2.0 About this manual

This manual is provided by JET, covering the safe operation and maintenance procedures for a JET Model JDP20EVST-PDF series Drill Press. This manual contains instructions on installation, safety precautions, general operating procedures, maintenance instructions and parts breakdown. Your machine has been designed and constructed to provide consistent, long-term operation if used in accordance with the instructions as set forth in this document.

If there are questions or comments, please contact your local supplier or JET. JET can also be reached at our web site: www.jettools.com.

Retain this manual for future reference. If the machine transfers ownership, the manual should accompany it.

⚠ WARNING Read and understand the entire contents of this manual before attempting assembly or operation! Failure to comply may cause serious injury!

3.0 Table of Contents

Section	Page
1.0 IMPORTANT SAFETY INSTRUCTIONS	2
1.1 Machinery general safety warnings	2
1.2 General electrical cautions	5
1.3 Safety instructions for drill presses	6
2.0 About this manual	6
3.0 Table of Contents	7
4.0 Specifications	8
4.1 Mounting hole centers (all models)	9
5.0 Set-Up and Assembly	8
5.1 Securing base	8
6.0 Electrical Connections	8
6.1 Electrical box access	8
6.2 GROUNDING INSTRUCTIONS	8
6.3 Extension cords	9
7.0 Adjustments	9
7.1 Table adjustment	9
7.2 Tool installation and removal	9
7.3 Speed pickup adjustment	9
7.4 Coolant pump	10
7.5 Powerfeed clutch adjustment	10
8.0 Operating controls	10
9.0 Operation	11
9.1 Operating precautions	11
9.2 Manual drilling	11
9.3 Manual tapping	11
9.4 Manual fine feed	11
9.5 Powerfeed drilling	11
9.6 Drilling recommendations	12
10.0 User-maintenance	12
10.1 Drive belt replacement	12
10.2 Motor replacement	13
10.3 Lubrication	13
10.4 Additional servicing	13
11.0 Troubleshooting JDP20EVST-PDF series Drill Presses	14
12.0 Replacement Parts	14
12.1.1 JDP20EVST-230/460-PDF Top Head Assembly – Exploded View	15
12.1.2 JDP20EVST-230/460-PDF Top Head Assembly – Parts List	16
12.2.1 JDP20EVST-230/460-PDF Spindle Components – Exploded View	18
12.2.2 JDP20EVST-230/460-PDF Spindle Components – Parts List	19
12.3.1 JDP20EVST-230/460-PDF Safety Shield Assembly – Exploded View	22
12.3.2 JDP20EVST-230/460-PDF Safety Shield Assembly – Parts List	22
12.4.1 JDP20EVST-230/460-PDF Table and Base Assembly – Exploded View	23
12.4.2 JDP20EVST-230/460-PDF Table and Base Assembly – Parts List	24
12.5.1 JDP20EVST-230/460-PDF Electrical Cabinet Assembly – Exploded View	26
12.5.2 JDP20EVST-230/460-PDF Electrical Cabinet Assembly – Parts List	27
12.6.1 JDP20EVST-230/460-PDF Control Panel Assembly – Exploded View	28
12.6.2 JDP20EVST-230/460-PDF Control Panel Assembly – Parts List	28
13.0 Electrical connections	29
13.1 JDP20EVST-230-PDF wiring diagram	29
13.2 JDP20EVST-460-PDF wiring diagram	30
14.0 Warranty and Service	31

4.0 Specifications

Model number	JDP20EVST-230-PDF	JDP20EVST-460-PDF
Stock number	354245.....	354246

Motor and Electricals:

Motor type	TEFC induction.....	TEFC induction
Horsepower	2 HP (1.5kW).....	2 HP (1.5kW)
Phase	3.....	3
Voltage	230 V only.....	460 V only
Cycle.....	60Hz.....	60Hz
Listed FLA (full load amps)	6 A.....	3 A
Motor speed.....	1720 RPM.....	1720 RPM
Inverter	B-type, 230V, 1/3PH.....	B-type, 460V, 3PH
Power input requirements.....	230V, 1 or 3 phase (prewired 1-phase)	460V, 3 phase
Power cable.....	14AWG, 6 ft.....	600V 14AWG, 6 ft.
Power plug.....	not provided.....	not provided
Recommended circuit and fuse/breaker size ¹	15 A.....	15 A
Sound emission without load ²	70 dB.....	70 dB
Coolant pump	1/8HP 230V 1PH.....	1/8HP 460V 3PH

Capacities:

Drills to center of circle	20 in. (508mm).....	20 in. (508mm)
Drilling capacity, cast iron	2.16 in. (55mm).....	2.16 in. (55mm)
Drilling capacity, mild steel	2 in. (50mm).....	2 in. (50mm)
Tapping capacity, cast iron	1 in.....	1 in.
Tapping capacity, mild steel	1 in.....	1 in.
Spindle to table distance, maximum	25.5 in. (648mm).....	25.5 in. (648mm)
Spindle to base distance.....	44.68 in. (1135mm).....	44.68 in. (1135mm)
Spindle to column distance	10-7/16 in. (265mm).....	10-7/16 in. (265mm)
Coolant capacity	2 gal. (9L).....	2 gal. (9L)
Quill downfeed rates	0.008, 0.004, 0.002 IPR.....	0.008, 0.004, 0.002 IPR
	(0.2, 0.1, 0.05 MMPR)	(0.2, 0.1, 0.05 MMPR)

Spindle:

Spindle taper	MT-4.....	MT-4
Spindle speed	variable.....	variable
Spindle speed range.....	60-540/225-2000.....	60-540/225-2000
Spindle travel.....	6 in. (152.4 mm).....	6 in. (152.4 mm)
Gear ratio.....	48/35T.....	48/35T
Rotation	fwd/rev.....	fwd/rev

Table and Column:

Table size.....	22 x 18-3/4 in. (559 x 476 mm).....	22 x 18-3/4 in. (559 x 476 mm)
Table working surface	18-1/8 x 14-3/4 in. (460 x 375 mm).....	18-1/8 x 14-3/4 in. (460 x 375 mm)
Table travel		
Without rack adjustment	15 in. (381mm).....	15 in. (381mm)
Maximum travel with rack adjustment.....	23.6 in. (600mm).....	23.6 in. (600mm)
T-slot number.....	3.....	3
T-slot size.....	5/8 in. (16mm).....	5/8 in. (16mm)
T-slot centers.....	7-7/16 in. (189mm).....	7-7/16 in. (189mm)
Table weight capacity	154 lb. (70kg).....	154 lb. (70kg)
Column diameter	4-1/2 in. (114mm).....	4-1/2 in. (114mm)

Base:

Base size.....	27 x 19 in. (686 x 483mm).....	27 x 19 in. (686 x 483mm)
Base working surface	14-3/4 x 11-13/16 in. (375 x 300mm).....	14-3/4 x 11-13/16 in. (375 x 300mm)
T-slot number	2.....	2
T-slot size.....	5/8 in. (16mm).....	5/8 in. (16mm)

Main materials:

Head	cast iron, steel cover.....	cast iron, steel cover
Table and Base.....	cast iron.....	cast iron
Spindle and Quill.....	steel.....	steel
Column	steel.....	steel

Dimensions:

Assembled machine dimensions (LxWxH).....42.5 x 27.16 x 78.74 in. (1080 x 690 x 2000mm).....
Shipping crate dimensions (LxWxH).....37"x25.5"x83"(940 x647 x2108 mm).....

Weights:

Net weight.....836 lb. (380 kg).....836 lb. (380 kg)
Shipping weight904 lb. (411 kg).....904 lb. 411 kg)

¹ Subject to local/national electrical codes.

² The specified values are emission levels and are not necessarily to be seen as safe operating levels. As workplace conditions vary, this information is intended to allow the user to make a better estimation of the hazards and risks involved only.

L = length, W = width, H = height

n/a = not applicable

The above specifications were current at the time this manual was published, but because of our policy of continuous improvement, JET reserves the right to change specifications at any time and without prior notice, without incurring obligations.

4.1 Mounting hole centers (all models)

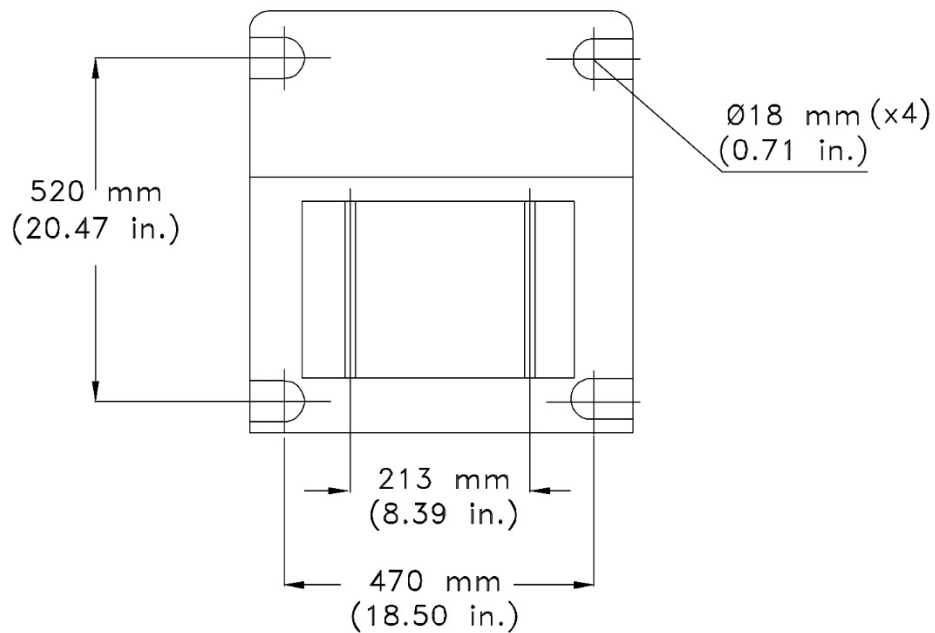

Figure 4-1: machine base mounting

5.0 Set-Up and Assembly

Inspect contents of crate for shipping damage. Report any damage immediately to your distributor and shipping agent. Do not discard any shipping material until drill press is assembled and running properly.

Remove any fasteners holding drill press to pallet. Lift drill press with forklift or hoist with straps. (Note: Lifting point is beneath head and next to column.) Make sure coolant hose, handles, etc. are clear of forks or straps when lifting. **Lifting equipment must be properly rated for weight of drill press.**

Locate the machine on a solid, level floor, preferably concrete. Area should have good overhead lighting and ventilation. (Refer to OSHA regulations for specific information about using drill presses in industrial environments.) The drill press should be level and rest solidly on floor. Place shims below base as needed to achieve level.

Exposed metal surfaces have been given a protective coating. Remove this with a soft cloth and a cleaner-degreaser or kerosene. Do not use gasoline, paint thinner or acetone, as these may damage painted surfaces. Do not use an abrasive pad, as it may scratch polished surfaces.

Coat all machined surfaces with a light coat of oil to inhibit rust.

5.1 Securing base

It is highly recommended that the drill press be secured to floor. The drill press base has four mounting slots; see Figure 4-1. When securing base to floor, apply even torque to the fasteners to prevent distortion of base.

6.0 Electrical Connections

⚠ WARNING Electrical connections must be made by a qualified electrician in compliance with all relevant codes. This machine must be properly grounded to help prevent electrical shock and possible fatal injury.

The **JDP20EVST-230-PDF** is pre-wired for single-phase, *230-volt*. It is not provided with an electrical plug; you may either attach a proper UL/CSA-listed plug, or “hardwire” the machine directly to a service panel. The machine can also be run on 3-phase, 230V power. See *sect. 6.2*.

The **JDP20EVST-460-PDF** is pre-wired for 3-phase, *460-volt*. It is not provided with an electrical plug; you may either attach a proper UL/CSA-listed plug, or “hardwire” the machine directly to a service panel. See *sect. 6.2*.

6.1 Electrical box access

The machine’s electrical box has a switch interface. Door will not open if main switch is ON.

6.2 GROUNDING INSTRUCTIONS

This tool must be grounded. In the event of a malfunction or breakdown, grounding provides a path of least resistance for electric current to reduce the risk of electric shock. This tool is equipped with an electric cord having an equipment-grounding conductor. If an electrical plug is to be used, the plug must be inserted into an appropriate outlet that is properly installed and grounded in accordance with all local codes and ordinances.

⚠ WARNING Improper connection of the equipment-grounding conductor can result in a risk of electric shock. Check with a qualified electrician or service person if you are in doubt as to whether the outlet is properly grounded.

The conductor with insulation having an outer surface that is green with or without yellow stripes is the equipment-grounding conductor. If repair or replacement of the electric cord or plug is necessary, do not connect the equipment-grounding conductor to a live terminal.

Repair or replace damaged or worn cord immediately.

If the drill press is to be hard-wired to a panel, make sure a disconnect is available for the operator. During hard-wiring of the machine, make sure the fuses have been removed or the breakers have been tripped in the circuit to which the drill press will be connected. ALWAYS FOLLOW PROPER LOCK-OUT/TAG-OUT PROCEDURES.

Model **JDP20EVST-230-PDF** is pre-wired for single phase, *230 volt only*. The machine can also be run on 3-phase power by hooking up the ground, L1, L2 and L3 wires, as explained below.

Model **JDP20EVST-460-PDF** (3-Phase) is pre-wired for *460 volt only*.

To wire the drill press:

If using a power cord, strip back the cord until about 3 to 4 inches of the lead wires are exposed. Slide a grommet onto the cord to be installed later in electrical box hole, to prevent stress to power cord.

1. Bring the lead wires through hole in machine’s electrical box and connect as follows (refer to Figure 6-1):
2. If your incoming power is **single phase**, connect the two leads to L1 and L2, and the green ground wire to the grounding screw.
3. If your incoming power is **three phase**, connect the three leads to L1, L2 and L3, and the green ground wire to the grounding screw.

Make sure incoming current matches power requirements of the drill. When machine is connected properly, spindle turns clockwise in a conventional drilling rotation. If spindle does not turn clockwise, disconnect drill from power supply and reverse any two of the three power leads (except green ground wire).

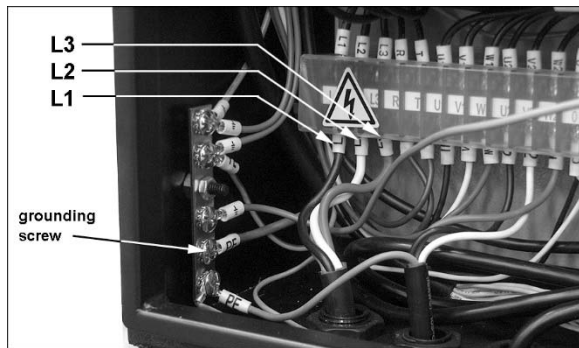

Figure 6-1: three-phase connection shown

6.3 Extension cords

The use of extension cords is discouraged; try to position equipment within reach of the power source. If an extension cord becomes necessary, be sure it is heavy enough to carry the current your product will draw. An undersized cord will cause a drop in line voltage resulting in loss of power and overheating.

Table 1 shows recommended size to use depending on cord length and nameplate ampere rating. If in doubt, use the next heavier gauge. The smaller the gauge number, the heavier the cord.

Ampere Rating		Volts	Total length of cord in feet			
More Than	Not More Than		50	100	200	300
		240	AWG			
0	6		18	16	16	14
6	10		18	16	14	12
10	12		16	16	14	12
12	16		14	12	Not Recommended	

Table 1: extension cord recommendations

7.0 Adjustments

7.1 Table adjustment

The table can be raised or lowered to accommodate workpiece height. Place hand crank on shaft (A, Figure 8-1) and turn counterclockwise to loosen table lock. Then use hand crank on shaft B or C to raise or lower table. Lock table in position using shaft A.

If drill press base is to be used for securing workpiece, loosen table (A) and swing it around column and out of the way. Retighten table.

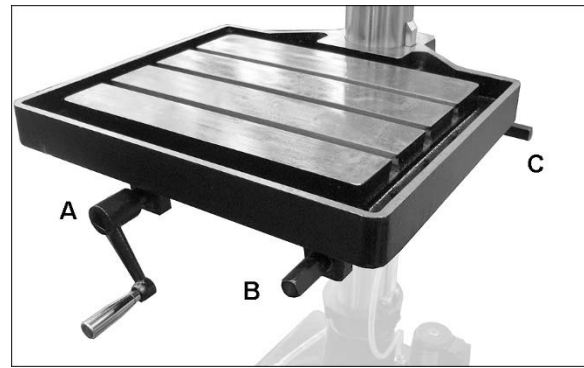

Figure 7-1: table adjustments

7.2 Tool installation and removal

1. Disconnect machine from power source.
2. Thoroughly clean inside of spindle with a soft dry cloth. Also clean any taper or arbor to be used in the spindle. If these are not kept clean, taper or arbor will not “seat” properly in spindle and may drop out unexpectedly.
3. Place protective piece of scrap wood on table.
4. Raise table to approximately 8-to-10 inches below spindle.
5. Insert MT-4 tool into spindle.
6. Lower spindle using downfeed handle, and seat tool against the wood.
7. If installing a drill chuck, retract the jaws then use rubber mallet (or steel face hammer against a block of wood) to sharply tap bottom of chuck two or three times to seat it. NOTE: Never use a steel face hammer directly against the chuck.

To remove a tool:

1. Disconnect machine from power source.
2. Lower spindle to expose slots in spindle wall.
3. Insert drift key into spindle slots and tap gently until drill bit or chuck arbor loosens. Hold tool with one hand (use glove or rag if needed) while tapping to prevent tool from falling and being damaged.

7.3 Speed pickup adjustment

Speed pickup has been set correctly by the manufacturer. If the speed readout display should lose accuracy, adjustment can be made as follows. Refer to index numbers on exploded view, sect. 12.1.1.

1. Loosen screws securing speed pickup (ref. #68) to plate (#69A).
2. Adjust speed pickup gap to approximately 1/8-inch. Retighten screws.
3. Operate drill press to verify that speed readout is operating correctly.

7.4 Coolant pump

The coolant system should be filled with 2 gallons of a cutting coolant. Fill by pouring coolant into base of machine. Add coolant in the same manner when coolant is low. To drain coolant, remove hex cap screw located on lower backside of base. Follow all coolant manufacturer's instructions for safety, mixing and disposal.

Make sure drain hose has good, tight connection into table and that coolant flows into base.

Make sure hose leaving pump and entering ball valve has good, tight connections.

The flexible nozzle enables user to adjust coolant for each job. One ball valve controls coolant flow to nozzle.

7.5 Powerfeed clutch adjustment

This adjustment has been made by the manufacturer (50 ft./lb. torque) and should not require immediate attention. If adjustment of overload clutch becomes necessary after extended use, remove panel and turn nut (Figure 7-2).

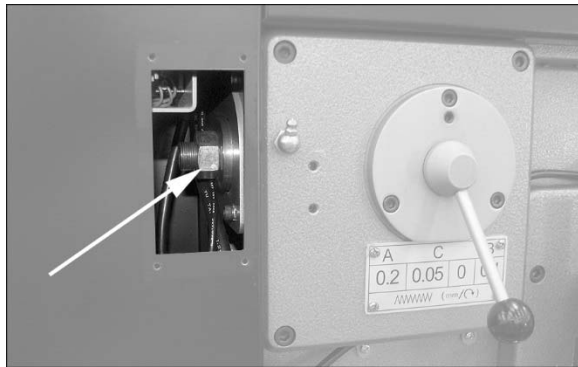

Figure 7-2

8.0 Operating controls

Refer to Figures 8-1 and 8-2.

The front panel area contains all the controls required to operate the drill press. The A.C. inverter in the electrical box does not require any programming, it is pre-programmed by the manufacturer. **Do not attempt to change inverter settings.** Use only the controls on the front panel. If you suspect a problem with the inverter or its settings, contact JET technical service at 1-800-274-6848.

Main switch (not shown): Located on electrical box cover. Turns on power to drill press.

Spindle On (A): Activates motor and spindle rotation.

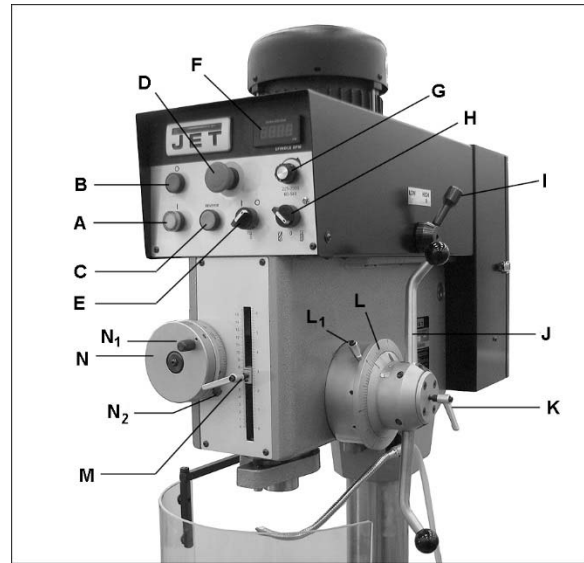

Figure 8-1: controls

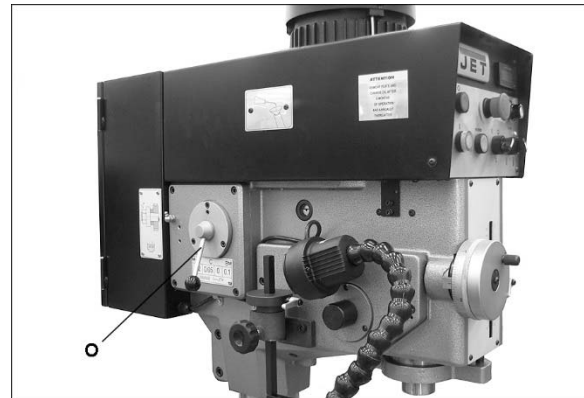

Figure 8-2: controls

Spindle off (B): Stops spindle rotation. (Other functions such as coolant pump will continue to operate.)

Reverse spindle (C): If tapping is interrupted, press this button to reverse tap from workpiece.

E-Stop (D): Emergency stop button shuts down all drill press functions. To restart drill press, turn E-stop button clockwise until it disengages.

Coolant pump (E): Starts and stops coolant pump circulation.

LED Display (F): Shows spindle RPM selected by speed control knob.

Speed control (G): Selects spindle rotation speed based upon range set by speed range handle.

Drill mode (H): Selects drill or tap mode. Middle position is neutral – spindle will not move.

Speed range handle (I): Selects high or low speed range. See sect. 4.0 for ranges. Stop spindle before moving handle.



Spindle must be stopped before attempting to adjust speed range handle. Failure to comply may damage speed adjustment mechanism.

Downfeed handle (J): Lowers quill/spindle. Engages powerfeed or manual fine feed when moved away from head. Can be pushed toward head to disengage power feed at any time.

Downfeed lock knob (K): Tighten to lock out powerfeed and keep drill in manual feed mode only.

Powerfeed scale (L): Graduated in 1/16 inch. Setting locked by screw (L₁).

Depth stop (M): Can be set for depths up to 6 inches (15.24 cm). Handle locks setting.

Fine feed handwheel (N): Manually feed spindle in fine increments. Clockwise to lower. Scale is graduated in 0.05 mm.

Feed rate lever (O):

NOTE: The Electronic Variable Speed unit is designed to shut down to prevent harm to the system, in the event of overloading the spindle. Make sure speed control knob (G) and speed range handle (I) are in matching ranges for the work being done. Drilling large holes requires speed range handle to be in 'Low' mode and speed control knob set to a speed high enough to power the large bit.

9.0 Operation

Refer to Figures 8-1 and 8-2.

9.1 Operating precautions

The following operating and safety precautions must be observed in order to avoid harm to operator or damage to drill press.

1. Head assembly must be locked to column so the thrust produced by drilling will not force the head assembly up the column.
2. Work table must be locked to column so it will not be forced down the column.
3. Belts should be properly tensioned.
4. Do NOT start to drill workpiece until making certain workpiece is held down securely.
5. Point of operation protection is required for maximum safety. This remains the responsibility of the user/purchaser since conditions differ between jobs.
6. Make sure tool is secured in the spindle or chuck before attempting to use the drill press.

7. Make sure spindle taper is clean and free of burrs, scoring, and galling to assure maximum gripping.

9.2 Manual drilling

1. Set switch (H) to drill mode.
2. Loosen handle (L₁) on powerfeed hub to allow full rotation of downfeed handle.
3. Use downfeed handle to set end of drill against surface of workpiece.
4. Loosen handle (M, Figure 8-2) and slide indicator block to zero. Then move indicator block to match drilling depth on scale, and tighten handle.
5. Start motor and drill hole until travel is restrained by indicator block.

9.3 Manual tapping

1. Set switch (H) to tapping mode. Limit switches are now active.
2. Set feed rate lever (O, Figure 8-3) to zero. (NOTE: Feed rate lever must be set to zero or spindle will not turn in manual tap mode.)
3. Set depth stop in same manner as above.
4. When quill is advanced, upper limit switch will be released for tapping. When lower limit switch is triggered, spindle will retract and reverse rotation for tap withdrawal. When upper limit switch is again reached, spindle will revert back to forward rotation.

NOTE: When tapping switch is off, limit switches are deactivated and do not affect spindle rotation.

9.4 Manual fine feed

1. Set switch (H) to drill mode.
2. Set depth of cut on powerfeed scale (L) and lock setting (L₁).
3. Turn on spindle (B).
4. Pull downfeed handle (J) away from head.
5. Push knob (N₁) into handwheel until it engages, and rotate handwheel (N). When set depth is reached, downfeed handle will disengage and spindle will retract.

9.5 Powerfeed drilling

NOTE: Feed rate lever (O, Figure 8-2) will only function in drill mode; powerfeed cannot be used in tapping mode.

1. Set switch (H) to drill mode.
2. Set depth stop (M).
3. Turn on spindle (B).
4. Move feed rate lever (O) to desired setting.

- Pull downfeed handle (J) away from head to engage powerfeed.
- When set depth is reached, downfeed handle will disengage and spindle will retract. Spindle will continue to rotate.

9.6 Drilling recommendations

9.6.1 Drilling speeds

The speed of a drill is usually measured in terms of the rate at which the outer periphery of the tool moves in relation to the work being drilled. The common term for this is Surface Feet per Minute (SFM). The relationship of SFM is expressed in the following formulas:

$$\text{SFM} = 0.26 \times \text{rpm} \times \text{Drill Diameter (in inches)}$$

$$\text{RPM} = 3.8 \times \frac{\text{SFM}}{\text{Drill diameter (in inches)}}$$

In general, the higher the speed the shorter the drill life. Operating at the low end of the speed range for a particular material will result in longer life. The most efficient speed for drill operation depends upon many variables:

- Composition and hardness of material.
- Depth of hole.
- Efficiency of cutting fluid.
- Type and condition of drilling machine.
- Desired quality of hole.
- Difficulty of set-up.

9.6.2 Drilling feed

The feed of a drill is governed by size of tool and the material drilled. Because feed rate partially determines rate of production and also is a factor in tool life, it should be chosen carefully for each job. In general, the most effective feeds will be found in the following ranges:

Diameter of Drill (inches)	Feed per Revolution (inches)
Under 1/8	0.001 to 0.002
1/8 to 1/4	0.002 to 0.004
1/4 to 1/2	0.004 to 0.007
1/2 to 5/8	0.007 to 0.015

Table 2

9.6.3 Excessive speed/feed indicators

A drill that splits up the web is evidence of too much feed or insufficient tip clearance at the center as a result of improper grinding. The rapid wearing away of the extreme outer corners of cutting edges indicates that speed is too high. A drill chipping or breaking out at the cutting edges indicates that either feed is too heavy or drill has been ground with too much tip clearance.

9.6.4 Speeds for high speed steel drills

Material	Speed (SFPM)
Alloy Steel — 300 to 400 Brinell	20-30
Stainless Steel	30-40
Automotive Steel Forgings	40-50
Tool Steel, 1.2C	50-60
Steel, .4C to .5C	70-80
Mild Machinery Steel, .2C to .3C	80-110
Hard Chilled Cast Iron	30-40
Medium Hard Cast Iron	70-100
Soft Cast Iron	100-150
Malleable Iron	80-90
High Nickel Steel or Monel	40-50
High Tensile Bronze	70-150
Ordinary Brass and Bronze	200-300
Aluminum and its Alloys	200-300
Magnesium and its Alloys	250-400
Slate, Marble, and Stone	15-25
Plastics and similar materials (Bakelite)	100-150
Wood	300-400
Titanium Alloys	10-25
Titanium Alloy Sheet	50-60

Note: In cases where carbon steel drills are applicable, the drill should be run at speeds of 40 to 50 percent of those given above.

Table 3

10.0 User-maintenance

10.1 Drive belt replacement

⚠WARNING Disconnect electrical power to drill press to avoid possibility of inadvertent operation and exposure to potentially lethal voltage levels.

- Disconnect machine from power source.
- Loosen set screw and remove speed range handle.
- Remove screws and take off pulley cover.
- Disconnect electrical wiring from motor junction box, and remove motor.
- Remove used belt. Install replacement belt.
- Install motor and connect electrical wiring (refer to sect. 13.0 for wiring details).
- Install pulley cover and secure with screws.
- Connect drill press to power and run machine to verify correct operation.

10.2 Motor replacement

⚠WARNING Disconnect electrical power to drill press to avoid possibility of inadvertent operation and exposure to potentially lethal voltage levels.

1. Disconnect machine from power source.
2. Follow steps under sect. 10.1 to remove drive motor.

10.3 Lubrication

See Table 4 for lubrication points and frequency.

Oil fill tube:

- a. Periodically check oil level in sight gauge (A, Figure 10-1).
- b. If level is below centerline of sight gauge, add oil.
- c. To add oil, remove oil fill tube cover plate. Pull fill tube out of hole in head cover (B).
- d. Add oil to bring oil level up to centerline of sight gauge.
- e. Push end of fill tube back into hole. Install fill tube cover and secure with two screws.

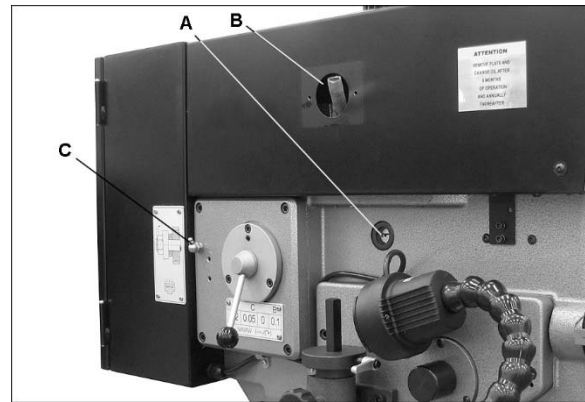

Figure 10-1: oil fill tube

10.4 Additional servicing

Any additional servicing should be performed by authorized service personnel.

Lubrication points		
Location	Recommended lubricant	Frequency
Splines on spindle shaft (access through hole atop pulley cover)	#2 lithium based tube grease	Monthly
Quill and column	Machine tool oil	Daily
Table raising rack	20W non-detergent oil	Weekly (clean rack with kerosene before lubricating)
Oil fill tube (behind plate on left side of drill head; B, Figure 10-1)	Mobil DTE™ Heavy Medium Oil, or equivalent	Change after initial 6 months, then annually thereafter. Capacity = 1 quart. Drain plug is located in cutaway section on underside of head; remove lower cover to access.
Grease fitting (C, Figure 10-1)	Mobil DTE™ Heavy Medium Oil, or equivalent	Monthly

Table 4

11.0 Troubleshooting JDP20EVST-PDF series Drill Presses

Trouble	Probable Cause	Remedy *
Spindle does not turn.	Overload protector tripped.	Press reset button on overload relay.
	Circuit breaker tripped.	Reset circuit breaker.
	Branch circuit breaker tripped or fuse blown.	Reset branch circuit breaker/replace fuse. Make sure incoming power matches machine specs.
	Open wire in switch circuit.	Repair open circuit.
	Defective switch.	Replace switch.
	Broken drive belt.	Replace drive belt.
Spindle noisy.	Damaged spindle bearings.	Replace bearings.
	Worn spline.	Replace spline.
	Insufficient lubrication.	Maintain proper lubrication.
Drill stalls.	Worn drive belt.	Check condition of belt. Replace if glazed or slipping on pulleys.
	Excessive feed rate for size of drill and material being drilled. No cutting fluid or improper cutting fluid.	Reduce feed pressure or use cutting fluid. Use correct cutting fluid.
Poorly drilled holes.	Dull drill.	Sharpen or replace drill.
	Lack of rigidity in hold-down method.	Check that all T-slot hold-downs are tight and that table-lock and drill head bolts are tight.
	Speed too fast for material and drill size.	Check spindle speed recommendations. Reduce speed if necessary.
	Feed too fast for material and drill size.	Reduce feed rate.
	No or improper cutting fluid or coolant being used.	Use cutting fluid, or change to proper fluid or coolant for material being drilled.
	Improperly ground drill bit.	Check for proper angles and reliefs. Regrind to proper geometry.
Motor overheating.	Electrical circuit fault.	Check current draw in circuit. Make sure current draw is the same as rating on motor plate.
	Oversize drill.	Reduce drill size.
	Excessive feed.	Reduce feed rate.
	No cutting fluid, or wrong fluid.	Use correct cutting fluid for the material and drill.
Table binding, or cannot be raised.	Lack of lubrication.	Clean and lubricate rack, column, shafts, or wherever needed.
No speed readout.	Speed pickup out of adjustment or failed.	Adjust gap between speed pickup and post spindle pulley. If there is no readout on the LED speed indicator after adjusting the gap, replace the speed pickup.

***WARNING:** Some corrections may require a qualified electrician.

Table 5

12.0 Replacement Parts

Replacement parts are listed on the following pages. To order parts or reach our service department, call 1-800-274-6848, Monday through Friday, 8:00 a.m. to 5:00 p.m. CST. Having the Model Number and Serial Number of your machine available when you call will allow us to serve you quickly and accurately.

Non-proprietary parts, such as fasteners, can be found at local hardware stores, or may be ordered from JET. Some parts are shown for reference only, and may not be available individually.

12.1.1 JDP20EVST-230/460-PDF Top Head Assembly – Exploded View

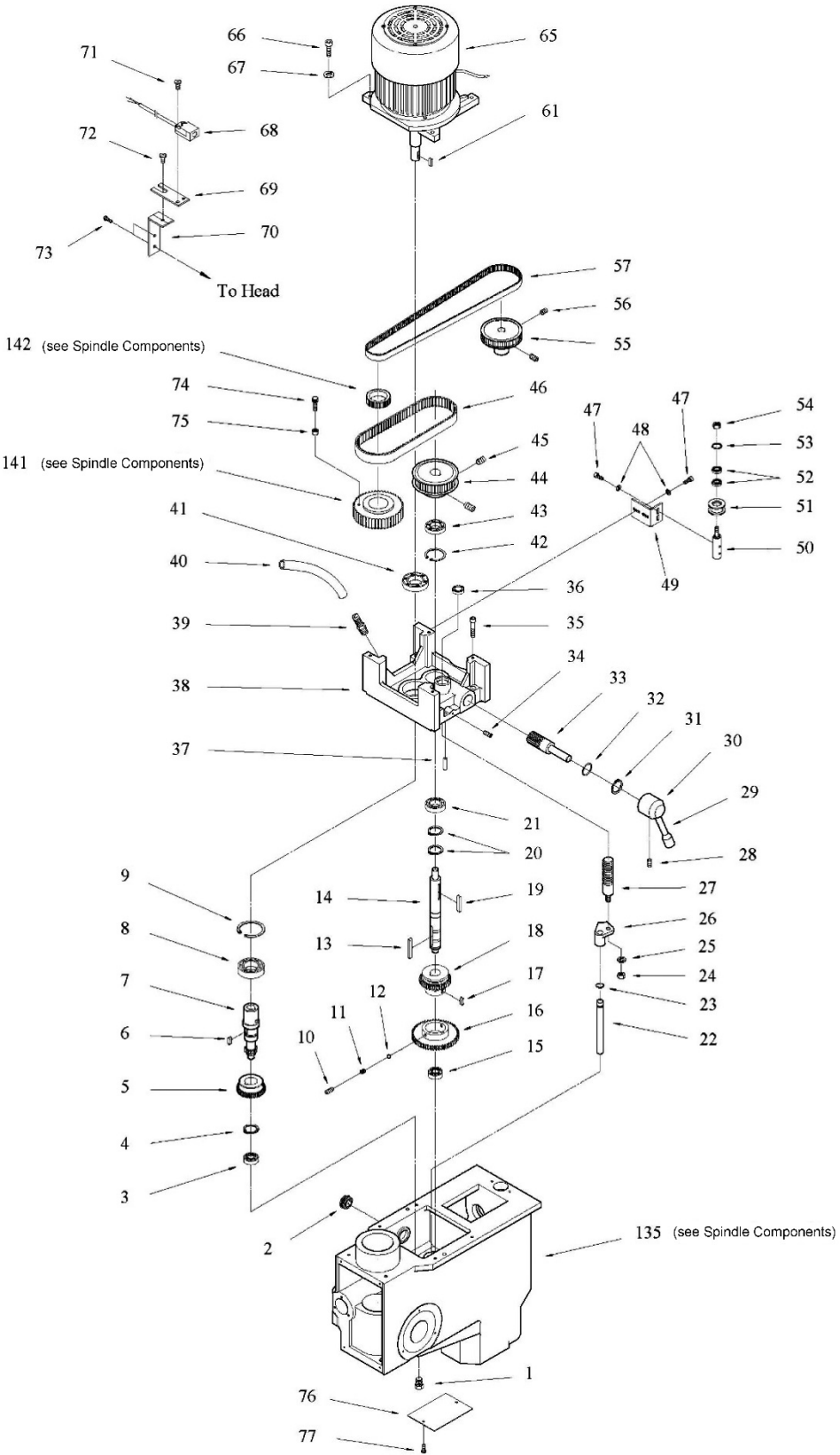

12.1.2 JDP20EVST-230/460-PDF Top Head Assembly – Parts List

Index No.	Part No.	Description	Size	Qty
1	JDP20EVSTPF-A01	Hex Head Plug	3/8"	1
2	5510142	Sight Glass		1
3	BB-6202ZZ	Ball Bearing	6202ZZ	1
4	20EVS-T04	C-Clip	S-31	1
5	5510145	Gear	M=2, T=32	1
6	5510146	Key	6x20 mm	1
7	5510147	Drive Shaft	M=2, T=13	1
8	BB-6007Z	Ball Bearing	6007Z	1
9	5510149	C-Clip	R-62	1
10	5510152	Set Screw	M10x10	2
11	5510155	Spring		2
12	SB-8MM	Steel Ball	8mm	2
13	5510160	Key	7x55 mm	1
14	5510161	Shaft		1
15	BB-6002Z	Ball Bearing	6002Z	1
16	5510153	Gear	M=2, T=56	1
17	5510159	Key	6x20 mm	1
18	5510158	Gear	M=2, T=36	1
19	5510162	Key	7x40 mm	1
20	5510163	C-Clip	S-25	2
21	BB-6005ZZ	Ball Bearing	6005ZZ	1
22	5510166	Rod		1
23	5517334	Oil Ring	P-11	1
24	5510167	Hex Nut	M10	1
25	5510168	Lock Washer	M10	1
26	5510169	Speed Change Block		1
27	5510170	Screw Bar		1
28	5510171	Set Screw	3/8"x3/8"	1
29	5517335	Handle		1
30	5517335-1	Speed Lever		1
31	5517336	C-Clip	R-30	1
32	5510173	Oil Ring	30x17x7 mm	1
33	5510177	Gear Shaft		1
34	5510178	Set Screw	M6x8	1
35	5510182	Hex Socket Cap Screw	M8x35	4
36	5510183	Oil Seal	25x5 mm	1
37	5510165	Taper Pin	5x38 mm	2
38	5517339	Gear Box		1
39	5510180	Oil Filter	3/8"x3/8"	1
40	5517340	Tube		1
41	5510181	Oil Seal	62x35x10 mm	1
42	5517341	C-Clip	R-47	1
43	5510184	Oil Seal	47x25x8 mm	1
44	5510186	Drive Pulley	8Mx35T	1
45	5510185	Set Screw	M8x8	2
46	5517343	Drive Belt	8Mx720	1
47	TS-1503041	Hex Socket Cap Screw	M6x16	4
48	TS-1550041	Washer	M6	4
49	JDP20EVSTPF-A49	Bracket		1
50	JDP20EVSTPF-A50	Shaft		1
51	JDP20EVSTPF-A51	Ball Bushing		1
52	BB-608	Ball Bearing	608	2
53	TS-2361081	Spring Washer	M8	1
54	TS-1540061	Hex Nut	M8	1
55	JDP20EVSTPF-A55	Rear Pulley w/ Gear	5Mx60T	1
56	TS-1524011	Set Screw	M8x8	2
57	JDP20EVSTPF-A57	Follow Belt	M5x1100x14	1
61	5510192	Key	6x20 mm	1

Index No.	Part No.	Description	Size	Qty
65	J-5517349	Motor	2HP/230V/3PH	1
	J-5517350	Motor	2HP/460V/3PH	1
66	5510195	Hex Socket Cap Screw	M8x25	4
67	TS-2361081	Spring Washer	M8	4
68	5513515	Sensor		1
69	5517383	Sensor Support		1
70	5517384	Mag. Pickup Bracket		1
71	5513687	Pan Head Screw	M4x20	2
72	5513689	Cap Screw	M8x12	1
73	5517387	Screw	M5x10	2
74	5517338	Hex Socket Cap Screw	3/16"x1"	1
75	5517337	Hex Nut	3/16"	1
76	JDP20EVSTPF-A76	Cover		1
77	JDP20EVSTPF-A77	Screw	M5x6	2
	LM000246	ID/Warning Label, JDP-20EVST-230-PDF (not shown)		1
	LM000247	ID/Warning Label, JDP-20EVST-460-PDF (not shown)		1
	JET-113	JET Logo (not shown)	113x47mm	1

12.2.1 JDP20EVST-230/460-PDF Spindle Components – Exploded View

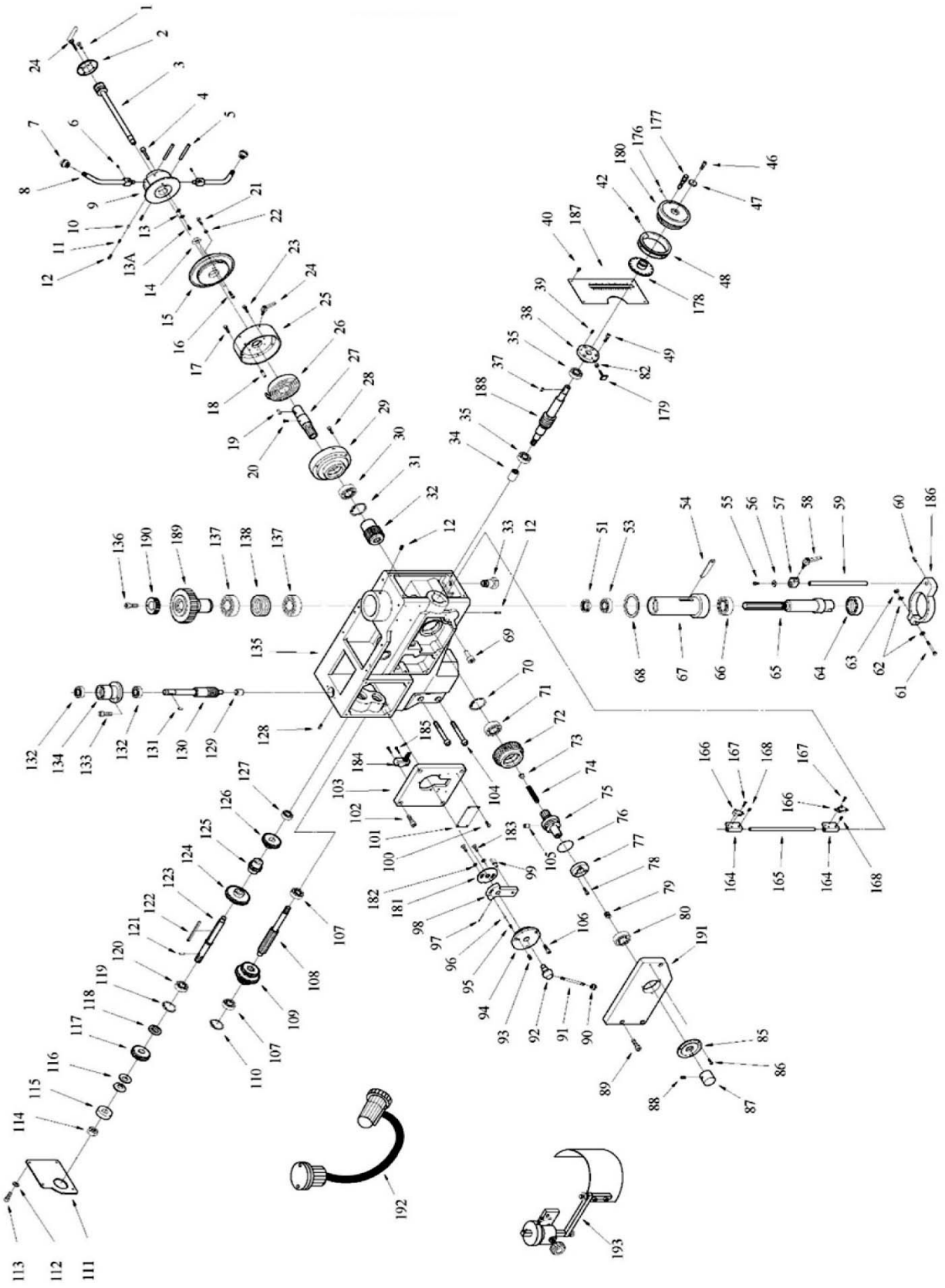

12.2.2 JDP20EVST-230/460-PDF Spindle Components – Parts List

Index No.	Part No.	Description	Size	Qty
1	TS-1514021	Socket Head Flat Screw	M6x16	4
2	JDP20EVSTPF-B02	Cover		1
3	JDP20EVSTPF-B03	Feed Clutch Rod		1
4	JDP20EVSTPF-B04	Pin		1
5	JDP20EVSTPF-B05	Roll Pin	8x70 mm	2
6	TS-1522011	Set Screw	M5x6	2
7	JDP20EVSTPF-B07	Grip		2
8	JDP20EVSTPF-B08	Feed Handle		2
9	JDP20EVSTPF-B09	Feed Handle Body		1
10	SB-1/4	Steel Ball	1/4"	1
11	JDP20EVSTPF-B11	Spring		1
12	TS-1524011	Set Screw	M8x8	1
13	TS-2361041	Spring Washer	M4	2
13A	TS-1501021	Socket Head Cap Screw	M4x8	1
14	JDP20EVSTPF-B14	Scale Guider		1
15	JDP20EVSTPF-B15	Scale Plate		1
16	TS-1501041	Socket Head Cap Screw	M4x12	2
17	TS-1503061	Socket Head Cap Screw	M6x25	3
18	JDP20EVSTPF-B18	Pin Screw	M8	1
19	5509112	Key	6x20 mm	1
20	F010946	Socket Head Flat Screw	M4x8	1
21	TS-1502021	Socket Head Cap Screw	M5x10	1
22	TS-1540031	Hex Nut	M5	1
23	TS-1501011	Socket Head Cap Screw	M4x5	1
24	JDP20EVSTPF-B24	Lever	M6x25	1
25	JDP20EVSTPF-B25	Spring Cap		1
26	JDP20EVSTPF-B26	Spring		1
27	JDP20EVSTPF-B27	Support Shaft		1
28	TS-1503071	Socket Head Cap Screw	M6x30	3
29	JDP20EVSTPF-B29	Spring Support		1
30	BB-6006ZZ	Ball Bearing	6006ZZ	1
31	JDP20EVSTPF-B31	C-Clip	R-30	1
32	JDP20EVSTPF-B32	Feed Shaft		1
33	JDP20EVSTPF-B33	Screw Bushing		1
34	JDP20EVSTPF-B34	Sleeve		1
35	BB-6004ZZ	Ball Bearing	6004ZZ	2
37	5301551	Key	5x15 m	1
38	JDP20EVSTPF-B38	Worm Shaft Support		1
39	TS-1523041	Set Screw	M6x12	3
40	TS-2245081	Socket Head Flat Screw	M5x6	4
42	JDP20EVSTPF-B42	Set Knob	1/4"	1
46	TS-1503041	Socket Head Cap Screw	M6x16	1
47	JDP20EVSTPF-B47	Special Washer		1
48	JDP20EVSTPF-B48	Scale Ring		1
49	TS-1503041	Socket Head Cap Screw	M6x16	3
51	JDP20EVSTPF-B51	Lock Nut		1
53	BB-30206	Tapered Roller Bearing	30206	1
54	JDP20EVSTPF-B54	Drill Shifter		1
55	TS-1503041	Socket Head Cap Screw	M6x16	1
56	TS-1550041	Washer	M6	1
57	JDP20EVSTPF-B57	Depth Scale Bracket		1
58	JDP20EVSTPF-B58	Lever	M6x25	1
59	JDP20EVSTPF-B59	Depth Rod		1
60	TS-2276081	Set Screw	M6x8	1
61	TS-0207101	Socket Head Cap Screw	1/4"-20x2"	1
62	TS-0720071	Spring Washer	1/4"	2
63	TS-0570011	Hex Nut	1/4"	1
64	OS724508	Oil Seal	72x45x8mm	1
65	JDP20EVSTPF-B65	Spindle		1

Index No.	Part No.	Description	Size	Qty
66	BB-32009ZZ	Tapered Roller Bearing	32009ZZ	1
67	JDP20EVSTPF-B67	Quill		1
68	JDP20EVSTPF-B68	Rubber Washer		1
69	JDP20EVSTPF-B69	Quill Support Pin		1
70	F006052	Ext. Retaining Ring	S-30	1
71	BB-6206ZZ	Ball Bearing	6206ZZ	1
72	JDP20EVSTPF-B72	Worm		1
73	JDP20EVSTPF-B73	Guide Plate		1
74	JDP20EVSTPF-B74	Spring		1
75	JDP20EVSTPF-B75	Jaw Clutch		1
76	JDP20EVSTPF-B76	Special Spring		1
77	JDP20EVSTPF-B77	Jaw Clutch Cover		1
78	TS-1514021	Socket Head Flat Screw	M6x16	3
79	JDP20EVSTPF-B79	Adjustable Screw		1
80	BB-6305ZZ	Ball Bearing	6305ZZ	1
82	TS-1541011	Hex Nut	M5	1
85	JDP20EVSTPF-B85	Cover		1
86	TS-1522041	Set Screw	M5x12	3
87	JDP20EVSTPF-B87	Cap		1
88	TS-1524011	Set Screw	M8x8	1
89	TS-1504041	Socket Head Cap Screw	M8x20	3
90	JDP20EVSTPF-B90	Grip		1
91	JDP20EVSTPF-B91	Speed Change Lever		1
92	JDP20EVSTPF-B92	Change Lever Body		1
93	TS-1524011	Set Screw	M8x8	1
94	JDP20EVSTPF-B94	Speed Change Bracket		1
95	JDP20EVSTPF-B95	Spring	M6x8	1
96	SB-8MM	Steel Ball	8mm	1
97	F012076	Roll Pin	5x30	1
98	JDP20EVSTPF-B98	Speed Change Support		1
99	JDP20EVSTPF-B99	Speed Change Pin		1
100	F010945	Socket Head Flat Screw	M4x6	4
101	JDP20EVSTPF-B101	Operating Lever Plate		1
102	TS-1504051	Socket Head Cap Screw	M8x25	4
103	JDP20EVSTPF-B103	Speed Change Cover		1
104	JDP20EVSTPF-B104	Hex Head Bolt	M12x80	2
105	JDP20EVSTPF-B105	Jaw		3
106	TS-1503041	Socket Head Cap Screw	M6x16	3
107	BB-6003ZZ	Ball Bearing	6003ZZ	2
108	JDP20EVSTPF-B108	Sliding Shaft		1
109	JDP20EVSTPF-B109	Speed Change Gear		1
110	F006054	Ext. Retaining Ring	R-35	1
111	JDP20EVSTPF-B111	Cover Plate		1
112	TS-2361061	Spring Washer	M6	4
113	TS-1503041	Socket Head Cap Screw	M6x16	4
114	TS-2311201	Hex Nut	M20	1
115	JDP20EVSTPF-B115	Spacer		1
116	JDP20EVSTPF-B116	Belleville Spring Washer		2
117	JDP20EVSTPF-B117	Worm		1
118	JDP20EVSTPF-B118	Spacer		1
119	JDP20EVSTPF-B119	C-Clip	R-42	1
120	BB-6004ZZ	Ball Bearing	6004ZZ	1
121	F012090	Roll Pin	5x18 mm	1
122	KEY0695	Key	6x95 mm	1
123	JDP20EVSTPF-B123	Shaft		1
124	JDP20EVSTPF-B124	Gear (L)		1
125	JDP20EVSTPF-B125	Intermediate Gear		1
126	JDP20EVSTPF-B126	Gear (S)		1
127	BB-6202ZZ	Ball Bearing	6202ZZ	1
128	TS-2276081	Set Screw	M6x8	1
129	JDP20EVSTPF-B129	Bushing		1
130	JDP20EVSTPF-B130	Rear Worm Gear		1

Index No.	Part No.	Description	Size	Qty
131	6293356	Key	6x20 mm	1
132	BB-6003ZZ	Ball Bearing	6003ZZ	2
133	TS-1504041	Socket Head Cap Screw	M8x20	2
134	JDP20EVSTPF-B134	Rear Worm Gear Bracket		1
135	JDP20EVSTPF-B135	Head Casting		1
136	TS-1503071	Socket Head Cap Screw	M6X30	3
137	BB-6009ZZ	Ball Bearing	6009ZZ	2
138	JDP20EVSTPF-B138	Bearing Spacer		1
164	JDP20EVSTPF-B164	Micro Switch Bracket		2
165	JDP20EVSTPF-B165	Micro Switch Support Rod		1
166	JDP20EVSTPF-B166	Micro Switch		2
167	F001160	Cross Pan Head Screw	M3x16	2
168	TS-0267021	Set Screw	1/4"-20x1/4"	2
176	JDP20EVSTPF-B176	Pin		1
177	JDP20EVSTPF-B177	Handwheel Handle		1
178	JDP20EVSTPF-B178	Pin Hole Plate		1
179	JDP20EVSTPF-B179	Pointer		1
180	JDP20EVSTPF-B180	Handwheel		1
181	JDP20EVSTPF-B181	Actuator Plate		1
182	TS-1550031	Flat Washer	M5	2
183	TS-1513011	Socket Head Flat Screw	M5x10	2
184	JDP20EVSTPF-B184	Limit Switch		1
185	TS-2244202	Socket Head Button Screw	M4x20	2
186	JDP20EVSTPF-B186	Feed Base		1
187	JDP20EVSTPF-B187	Depth Plate		1
188	JDP20EVSTPF-B188	Worm Shaft		1
189	JDP20EVSTPF-B189	Spindle pulley w/ Gear	8Mx48T	1
190	JDP20EVSTPF-B190	Gear	5Mx38T	1
191	JDP20EVSTPF-B191	Feed Cover		1
192	JDP20VST-WL	Work Light		1
193	32106A	Safety Shield		1

12.3.1 JDP20EVST-230/460-PDF Safety Shield Assembly – Exploded View

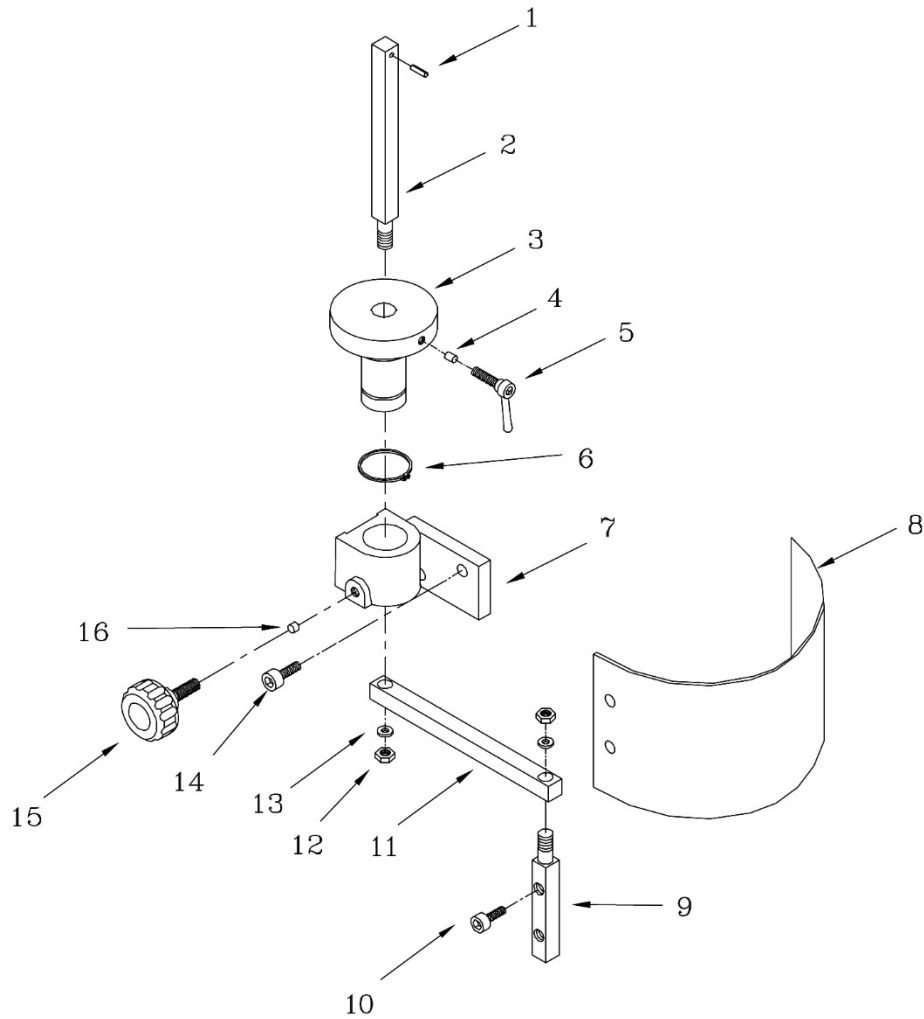

12.3.2 JDP20EVST-230/460-PDF Safety Shield Assembly – Parts List

Index No.	Part No.	Description	Size	Qty
.....	32106A.....	Safety Shield Assembly (includes #1 thru 16).....		1
1.....	6293347.....	Spring Pin.....	3x16.....	1
2.....	32106A-2.....	Support Bracket Bar.....		1
3.....	32106A-3.....	Bushing.....		1
4.....	32106A-4.....	Spacer.....		1
5.....	32106A-5.....	Lock Handle.....	M6x20.....	1
6.....	32106A-6.....	C-Clip.....	S30.....	1
7.....	32106A-7.....	Bracket.....		1
8.....	32106A-8.....	Safety Shield.....	530x210mm.....	1
9.....	32106A-9.....	Lower Bracket Bar.....		1
10.....	TS-1504021.....	Hex Socket Head Cap Screw.....	M8x12.....	1
11.....	32106A-11.....	Support Arm.....		1
12.....	TS-0640091.....	Hex Nut.....	3/8".....	1
13.....	TS-0720091.....	Spring Washer.....	3/8".....	1
14.....	TS-1504041.....	Hex Socket Head Cap Screw.....	M8x20.....	1
15.....	32106A-16.....	Lock Bolt with Knob.....	M8.....	1
16.....	32106A-17.....	Spacer.....		1

12.4.1 JDP20EVST-230/460-PDF Table and Base Assembly – Exploded View

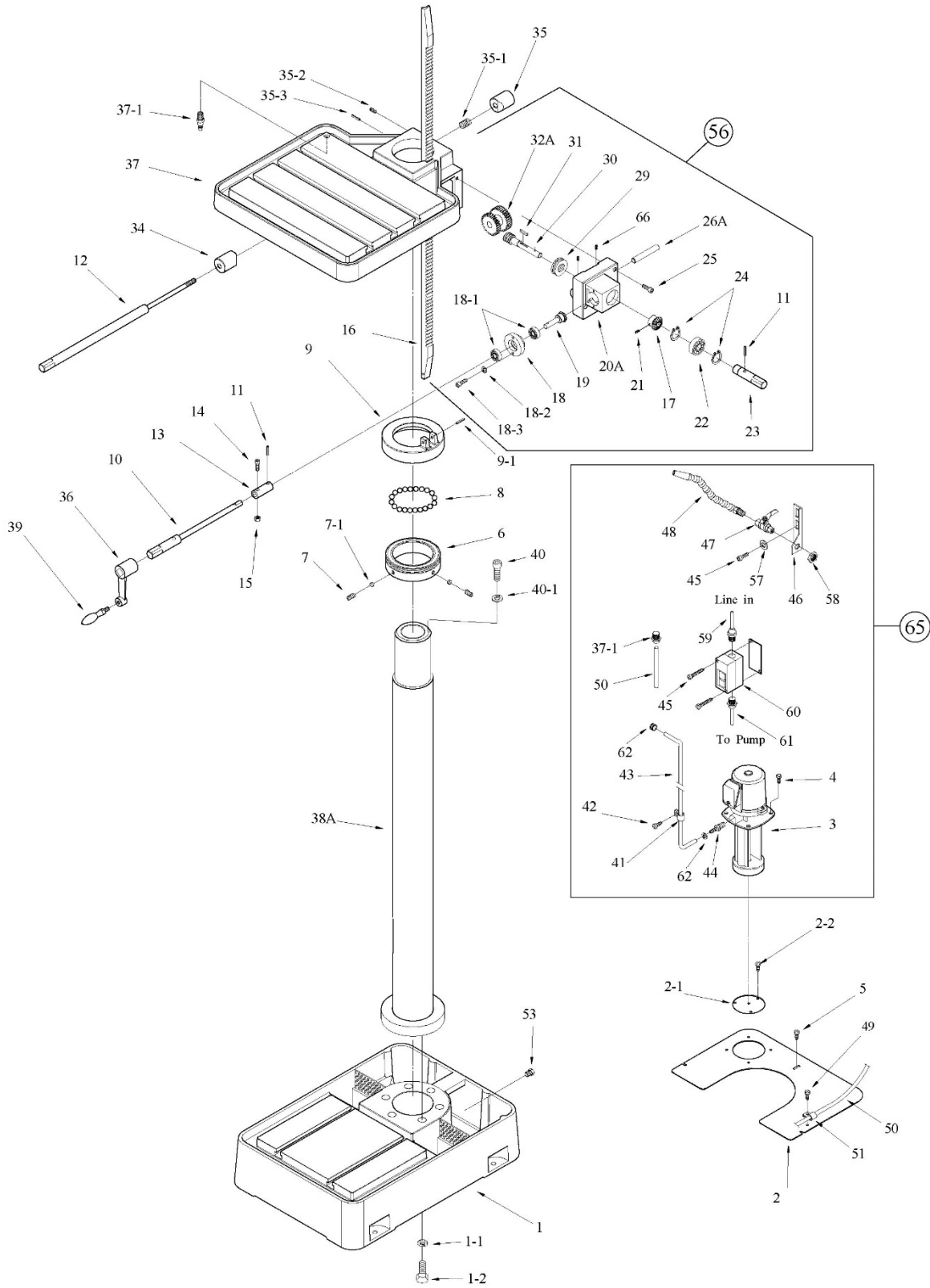

12.4.2 JDP20EVST-230/460-PDF Table and Base Assembly – Parts List

Index No.	Part No.	Description	Size	Qty
1	J-5510288A	Base		1
1-1	TS-0720111	Lock Washer	1/2"	6
1-2	TS-0070031	Hex Cap Screw	1/2"-13 x 1-1/2"	6
2	J-5510289	Coolant Cover Plate		1
2-1	20EVS-C2-1	Small Cover		1
2-2	20EVS-C4	Screw w/Washer	1/4"	3
3	5510456	Coolant Pump	115V/230V, 1P	1
	5512103	Coolant Pump	220/440V, 3P	1
4	TS-1482011	Hex Cap Screw	M6x10	4
5	5517388	Pan Head Screw		3
6	5510293A	Ball Seat		1
7	5510294	Set Screw	3/8"	2
7-1	5517389	Brass Block		2
8	5510295	Ball Bearing	3/8"	38
9	J-5510296A	Lock Ring		1
9-1	5517390	Pin	M4	1
10	5516859	Table Raiser Shaft		1
11	5510298	Spring Pin	4x20 mm	1
12	5516858	Table Clamp Shaft		1
13	5516860	Table Raiser Coupling		1
14	5510300	Socket Head Screw		1
15	TS-0561011	Hex Nut	1/4"	1
16	5510302	Rack		1
17	5514663	Large Bevel Gear		1
18	5517391	Bearing Housing		1
18-1	BB-6202ZZ	Ball Bearing	6202ZZ	2
18-2	TS-0720071	Lock Washer	1/4"	2
18-3	TS-1482041	Hex Cap Screw	M6x20	2
19	5510304	Small Bevel Gear		2
20A	J-5510305A	Bracket Cover		1
21	TS-0267041	Set Screw	1/4"-20x3/8"	1
22	BB-6005ZZ	Ball Bearing	6005zz	1
23	5510308	Shaft		1
24	20EVS-C24	C-Ring	S25	2
25	TS-1504071	Hex Socket Cap Screw	M8x35	3
26A	5510311A	Shaft		1
29	BB-51102	Bearing	51102	1
30	5510315	Table Raise Worm		1
31	20EVS-C31	Key	4x4x20 mm	1
32A	5510317A	Worm Gear Assembly		1
34	5510319	Front Cam Lock		1
35	5510320	Rear Cam Lock		1
35-1	5517396	Spring		1
35-2	TS-1523071	Set Screw	M6x25	1
35-3	5517398	Pin	5x25 mm	2
36	J-5510321	Table Raise Crank		2
37	JDP20VST-37	Table	3-Slot	1
37-1	5517399	Hose Coupler (Return)	1/2"	1
38A	JDP20EVSTPF-38A	Column		1
39	5510324	Table Raise Handle		1
43	5510328	Clear Vinyl Hose	3/8"	1
44	5510329	Hose Coupler (Supply)	3/8"	1
45	5512112	Socket Head Cap Screw	#10-32 x 1"	4
46	5510331	Mounting Bracket		1
47	5510332	Valve		1
48	5510333	Flexible Nozzle		1
49	5517400	Pan Head Screw		1
50	5517401	Clear Vinyl Hose	1/2"	1
51	5517402	Hose Clamp		1

Index No.	Part No.	Description	Size	Qty
53	5517404	Drain Plug	3/8 NPT	1
56	5513932	Table Raiser Assembly		1
57	TS-069204	Flat Washer	#10	2
58	5517488	Hex Nut	1/2"	1
59	5517489	Power Cord		1
60	5517490	Switch Assembly		1
61	5517491	Pump Cord	1 Phase	1
	5517492	Pump Cord	3 Phase	1
62	5517493	Hose Clamp, Rad. Type		2
65	5512104	Coolant System Complete	1/8 HP/115/230V/1PH	1
	5508071	Coolant System Complete	1/8 HP, 230/460V, 3PH	1
66	TS-1522021	Socket Set Screw	M5x8	2
	J2221-SBCA	Support Bearing Collar Assembly (includes #6,7,7-1,8,9,9-1)		1

12.5.1 JDP20EVST-230/460-PDF Electrical Cabinet Assembly – Exploded View

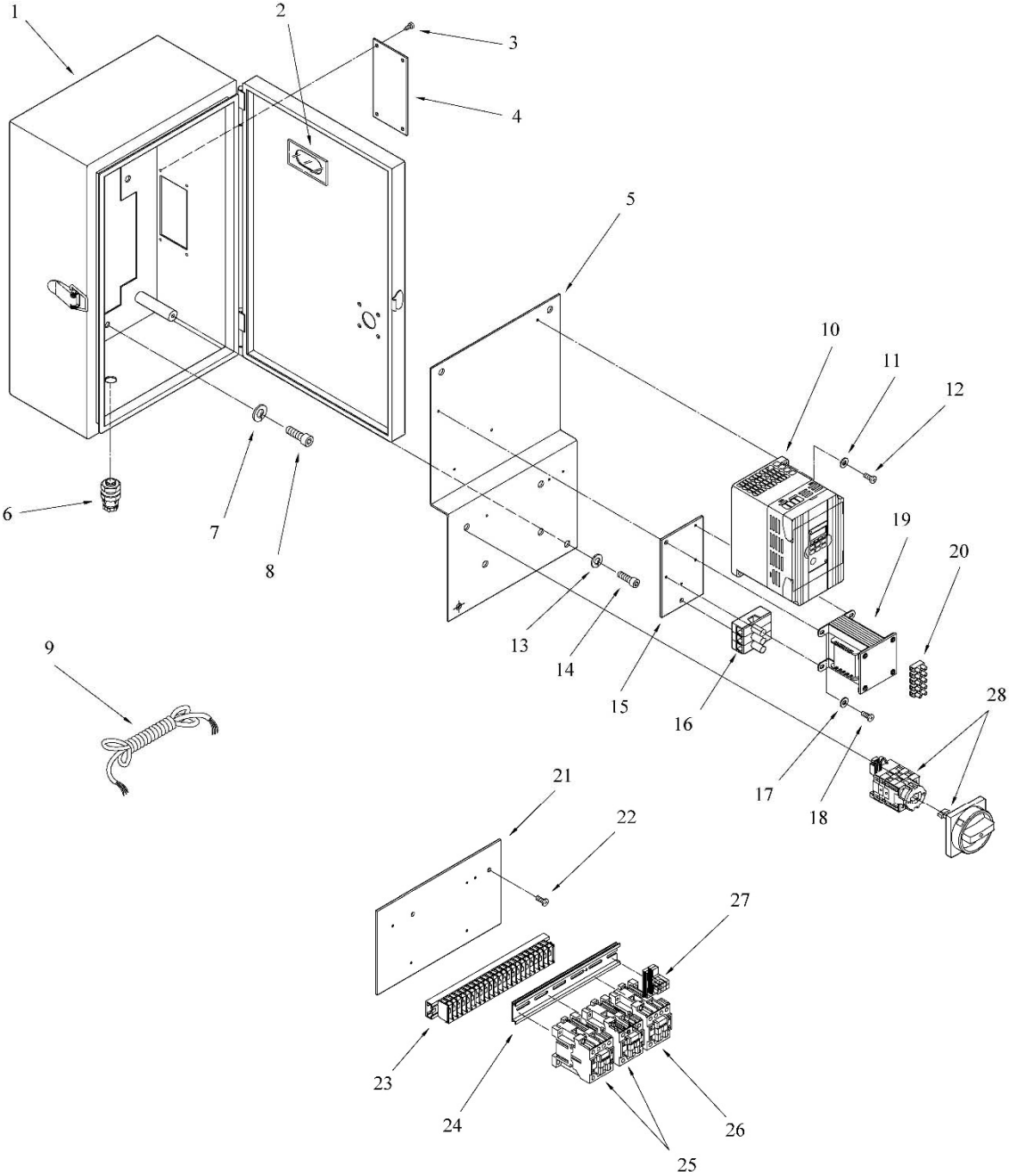

12.5.2 JDP20EVST-230/460-PDF Electrical Cabinet Assembly – Parts List

Index No.	Part No.	Description	Size	Qty
1	JDP20EVSTPF-E01	Electrical Box w/Door and Latch		1
2	JDP20EVSTPF-E02	Plastic Plate		1
3	TS-2171012	Pan Head Machine Screw	M4x6	4
4	JDP20EVSTPF-E04	Cover		1
5	JDP20EVSTPF-E05	Electric Base Plate		1
6	JDP20EVSTPF-E06	Cable Relief		1
7	TS-1550061	Washer	M8	4
8	TS-1504021	Socket Head Cap Screw	M8x12	4
9	JDP20EVSTPF-E09	Electric Cable		1
10	JDP20EVSTPF-10/460V	Delta Inverter	B-Type/2HP/460V/ 3PH	1
	JDP20EVSTPF-10/230V	Delta Inverter	B-Type/ 2HP/230V/ 1/3PH	1
11	TS-1550021	Washer	M4	2
12	TS-2284202	Pan Head Machine Screw	M4x20	2
13	TS-1550041	Washer	M6	1
14	TS-1503041	Socket Head Cap Screw	M6x16	1
15	JDP20EVSTPF-E15	Insulation Board	140x78x3	1
16	JDP20EVSTPF-E16	Fuse	1A	3
17	TS-1550021	Washer	M4	4
18	TS-2284202	Pan Head Machine Screw	M4x20	4
19	JDP20EVSTPF-19-460V	Transformer	460V / 110V/ 60VA	1
	JDP20EVSTPF-19-230V	Transformer	230V / 110V/ 60VA	1
20	JDP20EVSTPF-E20	Terminal Plate	230x130x3	1
21	JDP20EVSTPF-E21	Connecting Board		1
22	JDP20EVSTPF-E22	Screw	M4x8	5
23	JDP20EVSTPF-E23	Terminal Plate	23P/600V/10A	1
24	JDP20EVSTPF-E24	Aluminum Rail Plate		1
25	JDP20EVSTPF-E25	Contactora	D12/24V/12A	2
26	JDP20EVSTPF-E26	Over Relay		1
27	JDP20EVSTPF-E27	Relay		2
28	JDP20EVSTPF-E28	Main Switch Assembly		1

12.6.1 JDP20EVST-230/460-PDF Control Panel Assembly – Exploded View

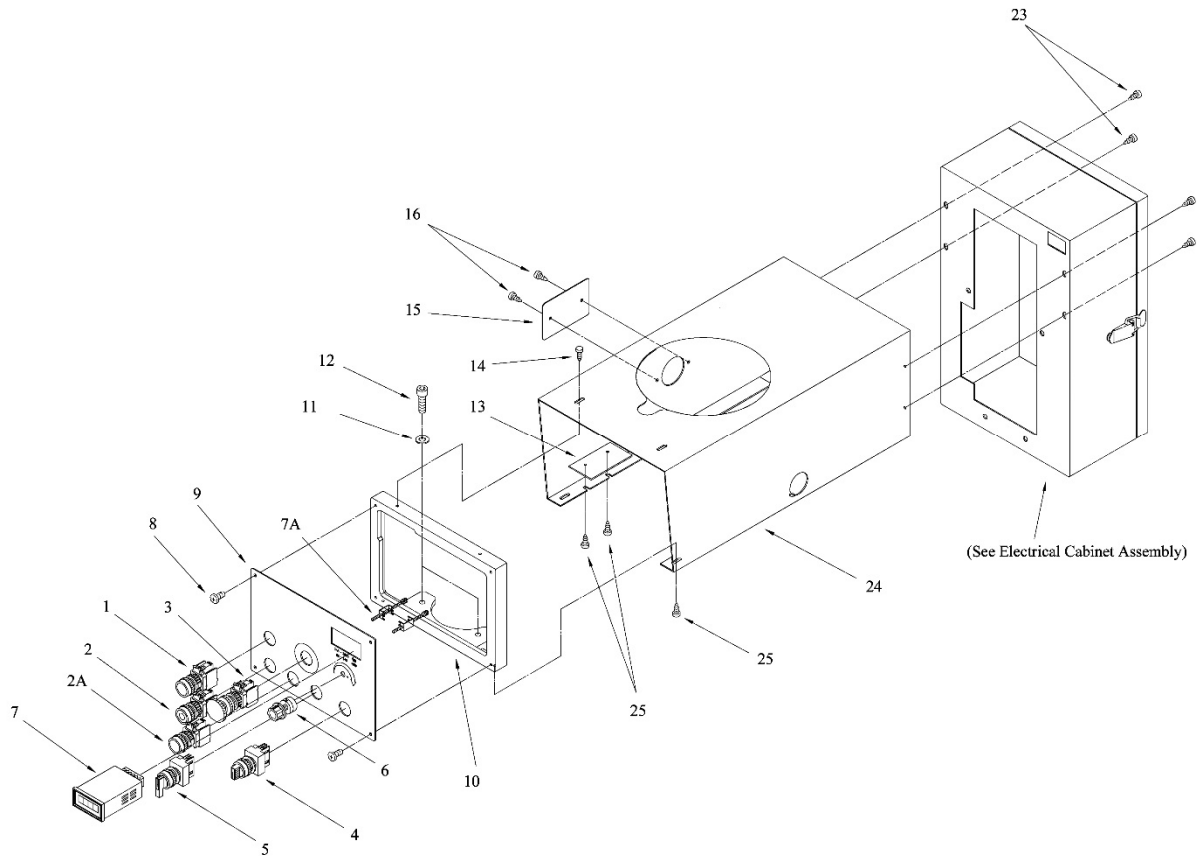

12.6.2 JDP20EVST-230/460-PDF Control Panel Assembly – Parts List

Index No.	Part No.	Description	Size	Qty
	JDP20EVSTPF-E01	Electric Control Box w/Door and Latch		1
1	JDP20EVSTPF-CP01	Start Switch		1
2	JDP20EVSTPF-CP02	Stop Switch		1
2A	JDP20EVSTPF-CP02A	Reverse Switch		1
3	JDP20EVSTPF-CP03	Emergency Stop Switch		1
4	JDP20EVSTPF-CP04	Selection Switch		1
5	JDP20EVSTPF-CP05	Pump Switch		1
6	JDP20EVSTPF-CP06	Speed Control Knob		1
7	JDP20EVSTPF-CP07	Speed Controller		1
7A	JDP20EVSTPF-CP07A	Holder Screw		2
8	TS-2235061	Socket Head Cap Screw	M5x6	4
9	JDP20EVSTPF-CP09	Control Panel		1
10	JDP20EVSTPF-CP10	Plate Bracket		1
11	JDP20EVSTPF-CP11	Washer	8mm	2
12	TS-1504041	Hex Socket Cap Screw	M8x20	2
13	JDP20EVSTPF-CP13	Cover		2
14	TS-1502021	Hex Socket Cap Screw	M5x10	2
15	JDP20EVSTPF-CP15	Oil Tube Cover	3/16"x3/8"	2
16	TS-2235061	Hex Socket Cap Screw	M5x6	2
23	TS-1503021	Hex Socket Cap Screw	M6x10	4
24	JDP20EVSTPF-CP24	Pulley Cover		1
25	TS-1502011	Hex Socket Cap Screw	M5x8	8

13.0 Electrical connections

These diagrams are also affixed inside electrical cabinet door. In case of discrepancy, diagram on machine takes precedence.

13.1 JDP20EVST-230-PDF wiring diagram

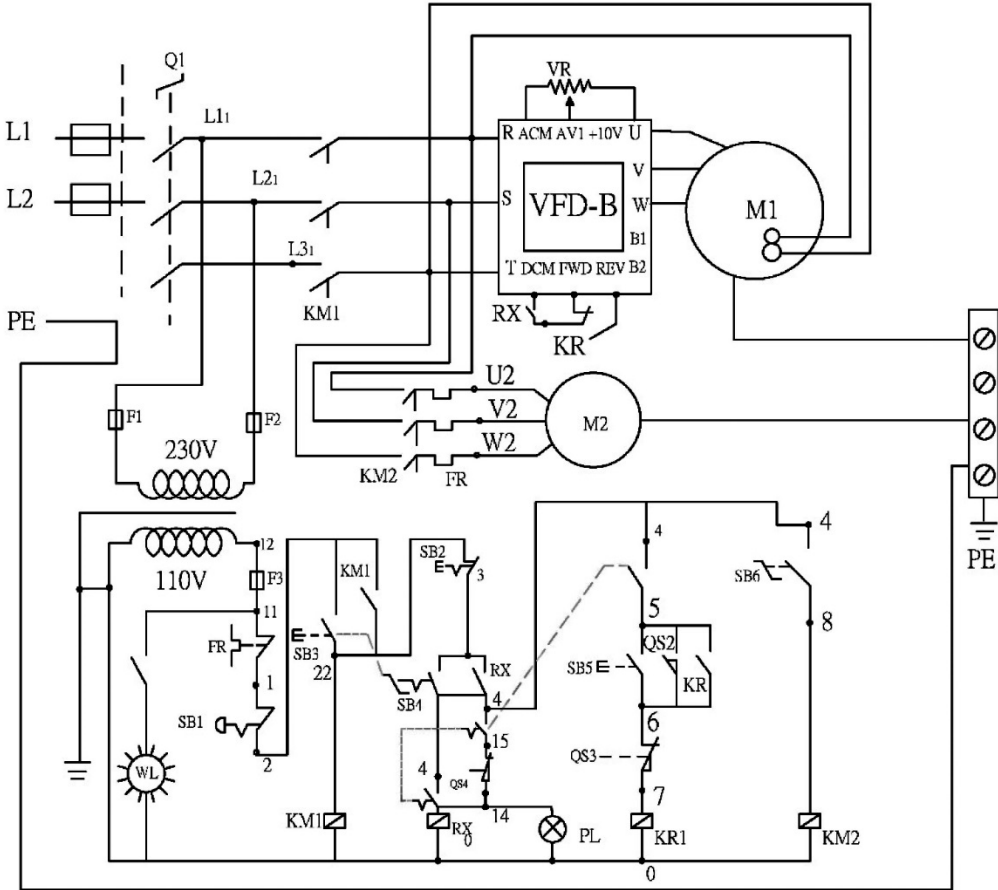

L1	L2	L3	R	T	U1	V1	W1	U2	V2	W2	0	1	2	22	3	4	14	5	15	6	7	8	9	C	V	+10V
----	----	----	---	---	----	----	----	----	----	----	---	---	---	----	---	---	----	---	----	---	---	---	---	---	---	------

13.2 JDP20EVST-460-PDF wiring diagram

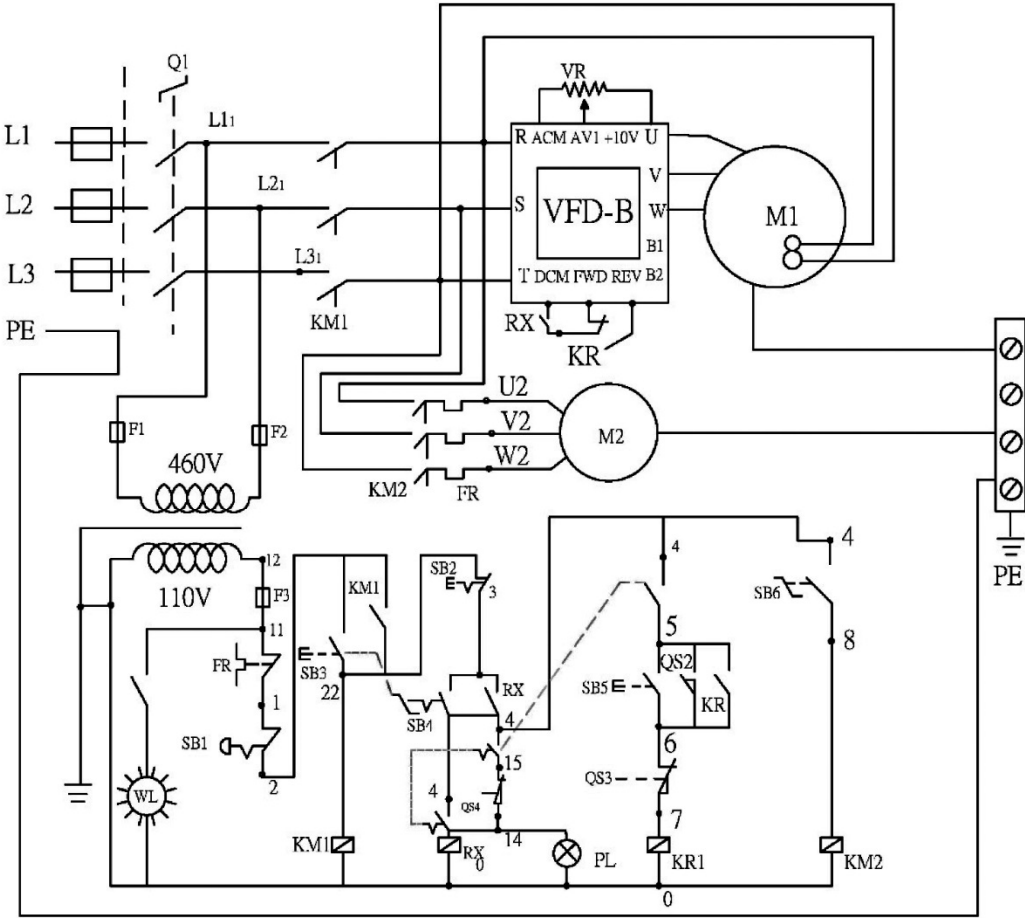

L1	L2	L3	R	T	U1	V1	W1	U2	V2	W2	0	1	2	22	3	4	14	5	15	6	7	8	9	C	V	+10V
----	----	----	---	---	----	----	----	----	----	----	---	---	---	----	---	---	----	---	----	---	---	---	---	---	---	------

14.0 Warranty and Service

JET warrants every product it sells against manufacturers' defects. If one of our tools needs service or repair, please contact Technical Service by calling 1-800-274-6846, 8AM to 5PM CST, Monday through Friday.

Warranty Period

The general warranty lasts for the time period specified in the literature included with your product or on the official JET branded website.

- JET products carry a limited warranty which varies in duration based upon the product. (See chart below)
- Accessories carry a limited warranty of one year from the date of receipt.
- Consumable items are defined as expendable parts or accessories expected to become inoperable within a reasonable amount of use and are covered by a 90 day limited warranty against manufacturer's defects.

Who is Covered

This warranty covers only the initial purchaser of the product from the date of delivery.

What is Covered

This warranty covers any defects in workmanship or materials subject to the limitations stated below. This warranty does not cover failures due directly or indirectly to misuse, abuse, negligence or accidents, normal wear-and-tear, improper repair, alterations or lack of maintenance. JET woodworking machinery is designed to be used with Wood. Use of these machines in the processing of metal, plastics, or other materials outside recommended guidelines may void the warranty. The exceptions are acrylics and other natural items that are made specifically for wood turning.

Warranty Limitations

Woodworking products with a Five Year Warranty that are used for commercial or industrial purposes default to a Two Year Warranty. Please contact Technical Service at 1-800-274-6846 for further clarification.

How to Get Technical Support

Please contact Technical Service by calling 1-800-274-6846. **Please note that you will be asked to provide proof of initial purchase when calling.** If a product requires further inspection, the Technical Service representative will explain and assist with any additional action needed. JET has Authorized Service Centers located throughout the United States. For the name of an Authorized Service Center in your area call 1-800-274-6846 or use the Service Center Locator on the JET website.

More Information

JET is constantly adding new products. For complete, up-to-date product information, check with your local distributor or visit the JET website.

How State Law Applies

This warranty gives you specific legal rights, subject to applicable state law.

Limitations on This Warranty

JET LIMITS ALL IMPLIED WARRANTIES TO THE PERIOD OF THE LIMITED WARRANTY FOR EACH PRODUCT. EXCEPT AS STATED HEREIN, ANY IMPLIED WARRANTIES OF MERCHANTABILITY AND FITNESS FOR A PARTICULAR PURPOSE ARE EXCLUDED. SOME STATES DO NOT ALLOW LIMITATIONS ON HOW LONG AN IMPLIED WARRANTY LASTS, SO THE ABOVE LIMITATION MAY NOT APPLY TO YOU.

JET SHALL IN NO EVENT BE LIABLE FOR DEATH, INJURIES TO PERSONS OR PROPERTY, OR FOR INCIDENTAL, CONTINGENT, SPECIAL, OR CONSEQUENTIAL DAMAGES ARISING FROM THE USE OF OUR PRODUCTS. SOME STATES DO NOT ALLOW THE EXCLUSION OR LIMITATION OF INCIDENTAL OR CONSEQUENTIAL DAMAGES, SO THE ABOVE LIMITATION OR EXCLUSION MAY NOT APPLY TO YOU.

JET sells through distributors only. The specifications listed in JET printed materials and on official JET website are given as general information and are not binding. JET reserves the right to effect at any time, without prior notice, those alterations to parts, fittings, and accessory equipment which they may deem necessary for any reason whatsoever. JET® branded products are not sold in Canada by JPW Industries, Inc.

Product Listing with Warranty Period

90 Days – Parts; Consumable items
1 Year – Motors; Machine Accessories
2 Year – Metalworking Machinery; Electric Hoists, Electric Hoist Accessories; Woodworking Machinery used for industrial or commercial purposes
5 Year – Woodworking Machinery
Limited Lifetime – JET Parallel clamps; VOLT Series Electric Hoists; Manual Hoists; Manual Hoist Accessories; Shop Tools; Warehouse & Dock products; Hand Tools; Air Tools

NOTE: JET is a division of JPW Industries, Inc. References in this document to JET also apply to JPW Industries, Inc., or any of its successors in interest to the JET brand.



427 New Sanford Road
LaVergne, Tennessee 37086
Phone: 800-274-6848
www.jettools.com