



PLEASE READ THE ENTIRE CONTENTS OF THIS MANUAL PRIOR TO INSTALLATION AND OPERATION. BY PROCEEDING YOU AGREE THAT YOU FULLY UNDERSTAND AND COMPREHEND THE FULL CONTENTS OF THIS MANUAL. FORWARD THIS MANUAL TO ALL OPERATORS. FAILURE TO OPERATE THIS EQUIPMENT AS DIRECTED MAY CAUSE INJURY OR DEATH.

**Manual Revision A5 - Feb. 2020**

**Manual Part Number 5900170**

## INSTALLATION AND OPERATION MANUAL

### Portable Column Lifting System

Model: PCL-18B



### READ FIRST



Do not operate this machine until you read and understand all the dangers, warnings and cautions in this manual.

Keep this operation manual near the machine at all times. Make sure that ALL USERS read this manual.

### IMPORTANT

Reference ANSI/ALI ALIS, Safety Requirements for Installation and Service of Automotive Lifts before installing lift.

#### SHIPPING DAMAGE CLAIMS

When this equipment is shipped, concerns for material damaged in shipment must be noted by the purchaser on the delivery receipt at the time shipment is received to ensure proper handling by the shipper.

#### BE SAFE

Your new lift was designed and built with safety in mind. However, your overall safety can be increased by proper training and thoughtful operation on the part of the operator. DO NOT operate or repair this equipment without reading this manual and the important safety instructions shown inside.



1645 Lemonwood Dr.  
Santa Paula, CA. 93060, USA  
Toll Free 1-800-253-2363  
Tel: 1-805-933-9970  
www.bendpak.com

# PCL-18B Portable Column Lift

This instruction manual has been prepared especially for you.  
Your new lift is the product of over 40 years of continuous research, testing and development;  
it is the most technically advanced lift on the market today.

## READ THIS ENTIRE MANUAL BEFORE INSTALLATION & OPERATION BEGINS

RECORD HERE THE LIFT AND  
POWER UNIT INFORMATION WHICH IS  
LOCATED ON THE SERIAL NUMBER  
DATA PLATES ON THE LIFT AND  
ON THE POWER UNIT

Power Unit Model # \_\_\_\_\_  
Power Unit Date Of Mfg. \_\_\_\_\_  
Power Unit Serial # \_\_\_\_\_

This information is required when  
calling for parts or warranty issues.

<b>BP BendPak</b>		Santa Paula, CA USA www.bendpak.com	
MODEL NUMBER			
SERIAL NUMBER			
LIFT CAPACITY		DESCRIPTION	
VOLTAGE			
<input type="checkbox"/> 110-240VAC, 50-60 Hz, 1 Ph	<input type="checkbox"/> 380-415VAC, 50-60 Hz, 3 Ph		
<input type="checkbox"/> 208-240VAC, 50-60 Hz, 1 Ph	<input type="checkbox"/> 208-440VAC, 50-60 Hz, 3 Ph		
DATE OF MFG.			
		<b>DANGER!</b>	
Disconnect Power Before Servicing		EAC	
WARRANTY VOID IF DATA PLATE IS REMOVED PN 5905951			

OUR LIFTS ARE SHIPPED WITHOUT OIL.  
ADD OIL TO POWER UNIT TANK BEFORE USE.  
READ SECTION 8 FOR MORE INFORMATION.



## PRODUCT WARRANTY

Our comprehensive product warranty means more than a commitment to you; it's also a commitment to the value of your new BendPak lift. For full warranty details contact your nearest BendPak dealer or visit:

<http://www.bendpak.com/support/warranty/>

## IMPORTANT NOTICE

Do not attempt to install this lift if you have never been trained on basic automotive lift installation procedures. Never attempt to lift components without proper lifting tools such as forklift or cranes. Stay clear of any moving parts that can fall and cause injury. These instructions must be followed to ensure proper installation and operation of your lift. Failure to comply with these instructions can result in serious bodily harm and void product warranty. Manufacturer will assume no liability for loss or damage of any kind, expressed or implied, resulting from improper installation or use of this product.

### PLEASE READ ENTIRE MANUAL PRIOR TO INSTALLATION.

### DEFINITIONS OF HAZARD LEVELS

Identify the hazard levels used in this manual with the following definitions and signal words:



Watch for this symbol. It means immediate hazards which will result in severe personal injury or death.



Beware of this symbol. It means hazards or unsafe practices could result in severe personal injury or death.



Take note of this symbol. It means hazards or unsafe practices which may result in minor personal injury, product or property damage.

## OWNER'S RESPONSIBILITY

To maintain the lift and user safety, the owner's responsibility is to read and follow these instructions:



- ◆ Follow all installation and operation instructions.
- ◆ Make sure installation conforms to all applicable Local, State, and Federal Codes, Rules, and Regulations; such as State and Federal OSHA Regulations and Electrical Codes.
- ◆ Carefully check the lift for correct initial function.
- ◆ Read and follow the safety instructions. Keep them readily available for machine operators.
- ◆ Make certain all operators are properly trained, know how to safely and correctly operate the unit, and are properly supervised.
- ◆ Allow unit operation only with all parts in place and operating safely.
- ◆ Carefully inspect the unit on a regular basis and perform all maintenance as required.
- ◆ Service and maintain the unit only with authorized or approved replacement parts.
- ◆ Keep all instructions permanently with the unit and all decals on the unit clean and visible.



## BEFORE YOU BEGIN

**NOTIFY THE CARRIER AT ONCE** if any hidden loss or damage is discovered after receipt and request the carrier to make an inspection. If the carrier will not do so, prepare a signed statement to the effect that you have notified the carrier (on a specific date) and that the carrier has failed to comply with your request.

**IT IS DIFFICULT TO COLLECT FOR LOSS OR DAMAGE AFTER YOU HAVE GIVEN THE CARRIER A CLEAR RECEIPT.** Support claim with copies of the Bill of Lading, freight bill, invoice, and photographs, if available. BendPak's willingness to assist in helping you process your claim does not make BendPak responsible for collection of claims or replacement of lost or damaged materials.

# TABLE OF CONTENTS

Warranty / Serial Number Information . . . . .2

Definitions of Hazard Levels . . . . . 3

Owner’s Responsibility . . . . .3

Before You Begin. . . . . 3

Installer/Operator Agreement/ Protective Equipment. . . . . 5

Safety / Warning Instructions . . . . . 6

Section 1 / Selecting Site . . . . .7

Section 2 / Floor Requirements . . . . .7

Concrete Specifications. . . . . 7

Assembly View / Parts Inventory . . . . . 8

Section 3 / Layout / Specifications /Clearances . . . . . 9-10

Section 4 / Hydraulic Jacking System . . . . . 11

Section 5 / Electrical Connections . . . . .12

Section 6 / Communication Cable and Positioning . . . . .13

Column Configuration . . . . . 14

Section 7 / Control Panels . . . . . 15-16

Section 8 / Initial Start-up and PLC System Overview . . . . . 17

Section 9 / Testing Procedures . . . . . 18

Section 10 / Operation Instructions . . . . . 19-23

Maintenance . . . . . 23-24

Product Decals . . . . . 25-28

Safe Lift Operation . . . . . 29-30

Troubleshooting and Faults . . . . . 31-34

Installation Form . . . . . 35

Part Breakdowns . . . . . 36-46

Crossbeam Accessory . . . . . 47

**INSTALLER / OPERATOR  
PLEASE READ AND FULLY  
UNDERSTAND. BY PROCEEDING  
YOU AGREE TO THE FOLLOWING:**

- ◆ I have visually inspected the site where the lift is to be installed and verified the concrete to be in good condition and free of cracks or other defects. I understand that installing a lift on cracked or defective concrete could cause lift failure resulting in personal injury or death.
- ◆ I understand that a level floor is required for proper installation and level lifting.
- ◆ I understand that I am responsible if my floor is of questionable slope and that I will be responsible for all charges related to pouring a new level concrete slab if required.
- ◆ I will assume full responsibility for the concrete floor and condition thereof, now or later, where the above equipment model is to be installed. Failure to follow Danger, Warning, and Caution instructions may lead to serious personal injury or death to operator or bystander or damage to property.
- ◆ I understand that BendPak lifts are designed to be installed in indoor locations only. Failure to follow installation instructions may lead to serious personal injury or death to operator or bystander or damage to property or lift.

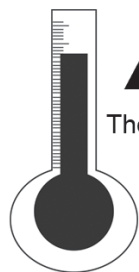

**CAUTION**

The safe operating temperature range for this product is 41° F - 104° F



Failure to follow Danger, Warning, and Caution instructions may lead to serious personal injury or death to operator or bystander or damage to property.



Please read the entire manual prior to installation. Do not operate this machine until you have read and have understood all of the Danger, Warning and Caution alerts in this manual. For additional copies or further information, contact:

**BendPak Inc.**

1645 Lemonwood Dr.

Santa Paula, CA. 93060

1-805-933-9970

[www.bendpak.com](http://www.bendpak.com)

**INSTALLER / OPERATOR  
PROTECTIVE EQUIPMENT**

Personal protective equipment helps to make installation and operation safer; however, it does not take the place of safe operating practices. Always wear durable work clothing during any installation and/or service activity. Shop aprons or shop coats may also be worn, however loose-fitting clothing should be avoided.

Tight-fitting leather gloves are recommended to protect the technician's hands when handling parts. Sturdy leather steel-toe work shoes and oil resistant soles should be used by all service personnel to help prevent injury during typical installation and operation activities.



Eye protection is essential during installation and operation activities. Safety glasses with side shields, goggles, or face shields are acceptable. Back belts provide support during lifting activities and are also helpful in providing worker protection. Consideration should also be given to the use of hearing protection if service activity is performed in an enclosed area, or if noise levels are high.



THIS SYMBOL POINTS OUT IMPORTANT SAFETY INSTRUCTIONS WHICH IF NOT FOLLOWED COULD ENDANGER THE PERSONAL SAFETY AND/OR PROPERTY OR YOURSELF AND OTHERS AND CAN CAUSE PERSONAL INJURY OR DEATH. READ AND FOLLOW ALL INSTRUCTIONS IN THIS MANUAL BEFORE ATTEMPTING TO OPERATE THIS MACHINE.

1. Carefully remove the crating and packing materials.  
**CAUTION!** Be careful when cutting steel banding material as items may become loose and fall causing personal harm or injury.

2. Check the voltage, phase and proper amperage requirements for the motor shown on the motor plate. Wiring should be performed by a certified electrician only.

## IMPORTANT SAFETY INSTRUCTIONS

Read these safety instructions entirely

### IMPORTANT NOTICE

Do not attempt to install this lift if you have never been trained on basic automotive lift installation procedures.

Never attempt to lift components without proper lifting tools such as forklift or cranes. Stay clear of any moving parts that can fall and cause injury.

1. READ and understand all instructions and all safety warnings before operating lift.
2. Care must be taken as burns can occur from touching hot components.
3. DO NOT operate equipment with a damaged cord or if the equipment has been dropped or damaged until it has been examined by a qualified service person.
4. DO NOT let a cord hang over the edge of the table, bench, or counter or come in contact with hot manifolds or moving fan blades.
5. If an extension cord is necessary, a cord with a current rating equal to or more than that of the equipment should be used. Cords rated for less current than the equipment may overheat. Care should be taken to arrange the cord so that it will not be tripped over or pulled.
6. ALWAYS unplug equipment from electrical outlet when not in use. Never use the cord to pull the plug from the outlet. Grasp plug and pull to disconnect.
7. Let equipment cool completely before putting away. Loop cord loosely around cable hook when storing.
8. DO NOT operate equipment in the vicinity of open containers of flammable liquids (gasoline) to reduce the risk of fire.
9. Adequate ventilation should be provided when working on operating internal combustion engines.
10. Keep hair, loose clothing, fingers, and all parts of body away from moving parts. Keep feet clear of lift when lowering. Avoid pinch points.
11. DANGER! To reduce the risk of electric shock, do not use on wet surfaces or expose to rain. The power unit used on this lift contains high voltage. Disconnect power at the receptacle or at the circuit breaker switch before performing any electrical repairs. Secure plug so that it cannot be accidentally plugged in during service. Or mark circuit breaker switch so that it cannot be accidentally switched on during service.



12. Use only as described in this manual. Use only manufacturer's recommended attachments.

13. ALWAYS WEAR SAFETY GLASSES. Everyday eyeglasses only have impact resistant lenses, they are not safety glasses.



14. CONSIDER WORK ENVIRONMENT. Keep work area clean. Cluttered work areas invite injuries. Keep areas well lit.  
15. GUARD AGAINST ELECTRIC SHOCK. This lift must be grounded while in use to protect operator from electric shock. Never connect the green power cord wire to a live terminal. This is for ground only.

16. Only trained operators should operate this lift. All non-trained personnel should be kept away from the work area. Never let non-trained personnel come in contact with, or operate lift.

17. DO NOT override self-closing lift controls.

18. CLEAR AREA if vehicle is in danger of falling.

19. ALWAYS make sure the safeties are engaged before attempting to work on or near a vehicle.

20. WARNING! RISK OF EXPLOSION. This equipment has internal arcing or sparking parts which should not be exposed to flammable vapors. This machine should not be located in a recessed area or below floor level.



21. MAINTAIN WITH CARE. Keep lift clean for better and safer performance. Follow manual for proper lubrication and maintenance instructions. Keep control handles, buttons and displays dry, clean and free from grease and oil.

22. Check for damaged parts. Check for alignment of moving parts, breakage of parts or any condition that may affect operation of lift. Do not use lift if any component is broken or damaged.

23. NEVER remove safety related components from the lift. Do not use lift if safety related components are missing or damaged.

24. STAY ALERT. Use common sense and watch what you are doing. Remember, SAFETY FIRST.

**SAVE THESE INSTRUCTIONS**

## IMPORTANT INSTRUCTIONS

These instructions must be followed to ensure proper installation and operation of your lift. Failure to comply with these instructions can result in serious bodily harm and void product warranty. Manufacturer will assume no liability for loss or damage of any kind, expressed or implied, resulting from improper installation or use of this product.

PLEASE READ ENTIRE MANUAL PRIOR TO INSTALLATION

### SECTION 1 (SELECTING SITE)

Before installing your new lift, check the following.

1. **LIFT LOCATION:** Always use architectural plans when available. Check the layout dimension against the floor plan requirements, making sure that adequate space is available.
2. **OVERHEAD OBSTRUCTIONS:** The area where the lift will be located should be free of overhead obstructions such as heaters, building supports, electrical lines, etc.
3. **DEFECTIVE FLOOR:** Visually inspect the site where the lift is to be installed and check for cracked or defective concrete.
4. Lift is designed for **INDOOR INSTALLATION ONLY**. Outdoor installation is prohibited. Always follow warnings illustrated on equipment labels.



### SECTION 2 (FLOOR REQUIREMENTS)

This lift must be installed on a solid level concrete floor with no more than 3-degrees of slope. Failure to do so could cause personal injury or death.

A level floor is suggested for proper use, installation and level lifting. If a floor is of questionable slope, consider a survey of the site and/or the possibility of pouring a new level concrete slab.

OUR LIFTS ARE SHIPPED WITHOUT OIL.  
ADD OIL TO POWER UNIT TANK BEFORE USE.



- ◆ **DO NOT** install or use this lift on any asphalt surface or any surface other than concrete.
- ◆ **DO NOT** install or use this lift on expansion seams or on cracked or defective concrete.
- ◆ **DO NOT** install or use this lift on a second / elevated floor without first consulting building architect.
- ◆ **DO NOT** install or use this lift in extremely damp environments.
- ◆ **DO NOT** install this lift outside. It is only approved for indoor installations.
- ◆ Refer to ANSI/ALI ALIS Standard (R2015) *Safety Requirements for Installation and Service* for more information about safely installing your Lift.

LIFT MODEL	CONCRETE REQUIREMENTS
PCL-18B	5" Min Thickness



ALL MODELS MUST BE INSTALLED ON CONCRETE ONLY CONFORMING TO THE MINIMUM REQUIREMENTS SHOWN ABOVE. NEW CONCRETE MUST BE ADEQUATELY CURED BY AT LEAST 28 DAYS MINIMUM.



When removing the lift from shipping angles, pay close attention as the columns can slide and can cause injury. Be careful when cutting steel banding material as items may become loose and fall causing personal harm or injury. Prior to removing the pallets make sure the posts are held securely by a fork lift or some other heavy lifting device.

### PCL-18B PARTS INVENTORY

Be sure to take a complete inventory of parts prior to beginning installation.

Description	Qty
Column Assembly	4
Carriage Assembly	4
Fork Arm Weldment	8
Displacement Sensor Cover	4
Control Box Assembly	4
Motor Cover Assembly	4
Parts Box (Packing List Enclosed)	4
Hydraulic Jack	4
Hydraulic Power Unit	4

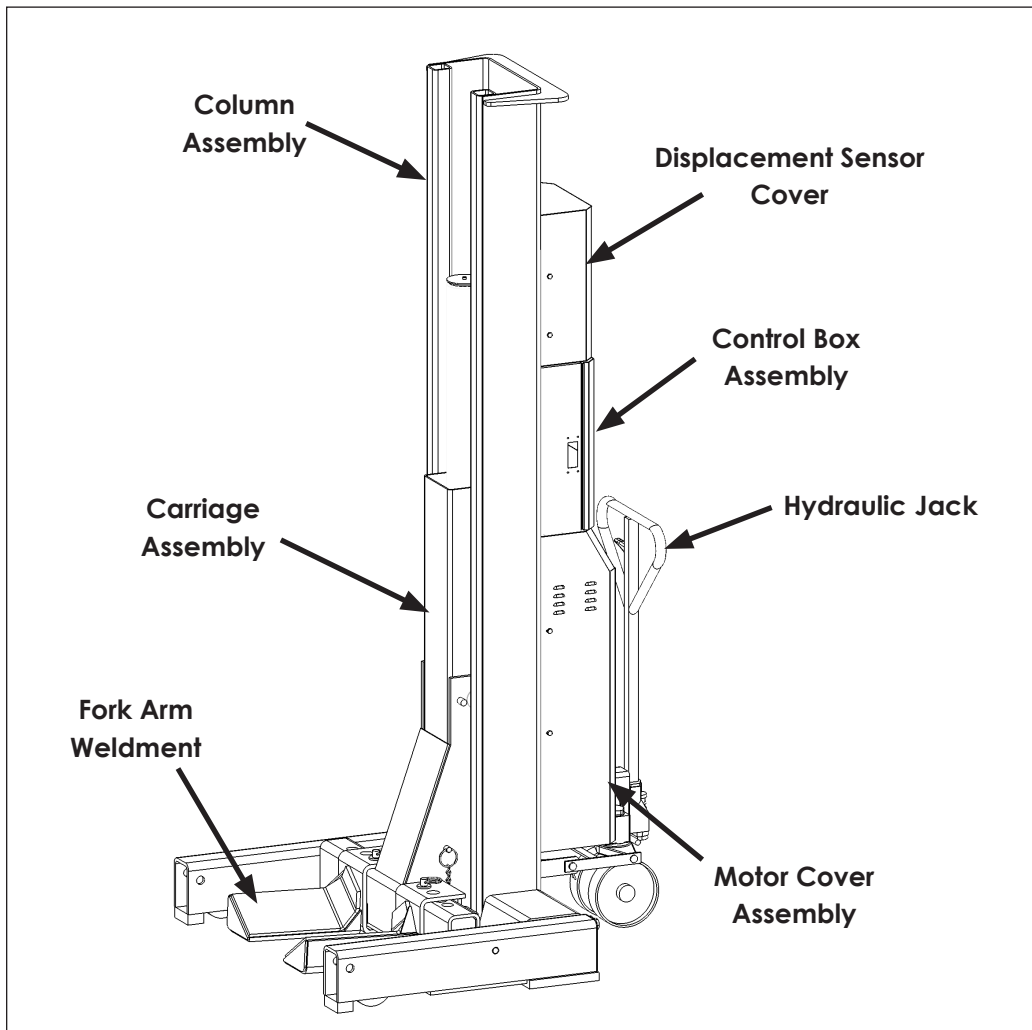

### SECTION 3 (LAYOUT)

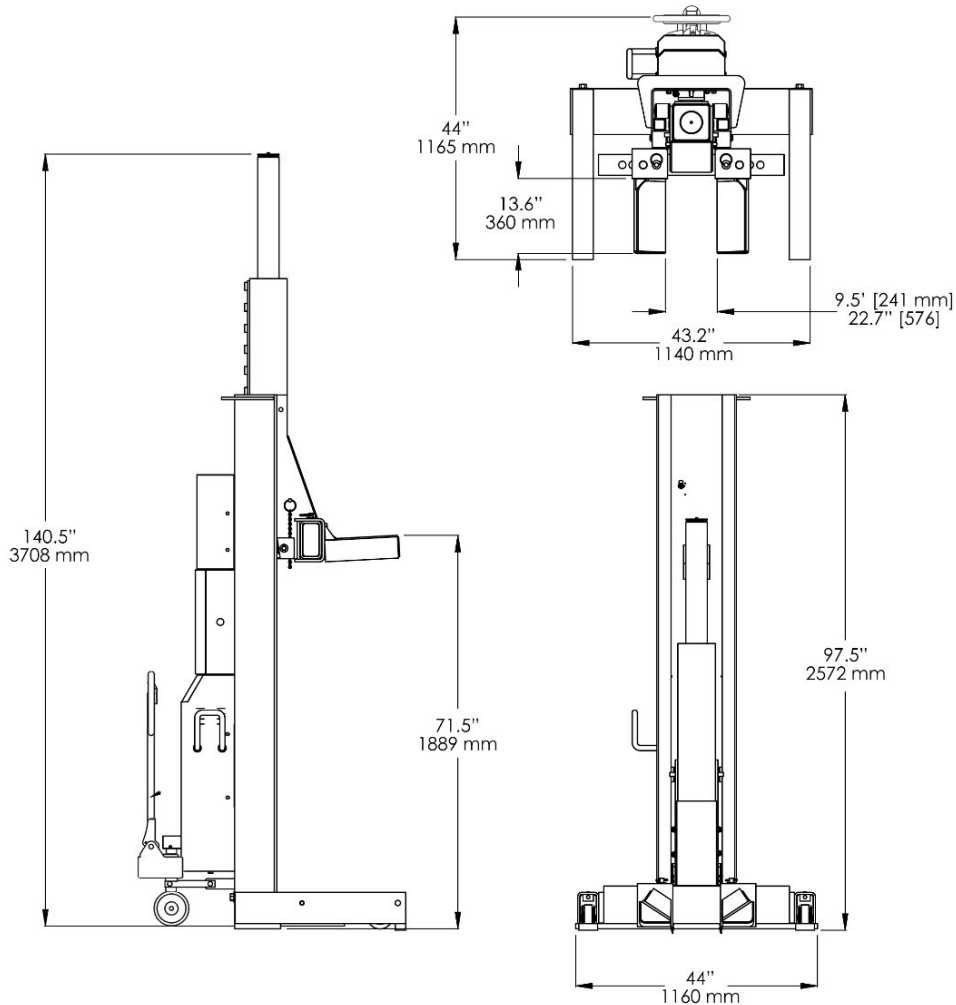

<b>PCL-18B</b>	
<b>Maximum Column Capacity</b>	<b>Each Column 18,000 Lbs. / 8,165 Kg</b>
<b>Configuration</b>	<b>Sold in sets of 2, 4 or 6 columns</b>
<b>Min. Column Height</b>	<b>97.5" / 2,572 mm</b>
<b>Maximum Lifting Height</b>	<b>71.5" / 1,889 mm</b>
<b>Length Lifting Fork</b>	<b>13.6" / 360 mm</b>
<b>Overall Length / Depth</b>	<b>47.5" / 1,206 mm</b>
<b>Width Inside Lifting Fork / Min.</b>	<b>9.5" / 241 mm</b>
<b>Width Inside Lifting Fork / Max.</b>	<b>22.7" / 576 mm</b>
<b>Overall Width</b>	<b>44" / 1,160 mm</b>
<b>Turning Circle</b>	<b>40" / 1,016 mm</b>
<b>Column Weight</b>	<b>Each 1450 lbs. / 657 kg.</b>
<b>Lifting Speed</b>	<b>85 Seconds</b>
<b>Motor / 2HP *</b>	<b>208-240 V 50/60 Hz, 3 Phase</b>
* Special Voltages Available Upon Request	
The design, material and specifications are subject to change without notice.	

# CLEARANCES

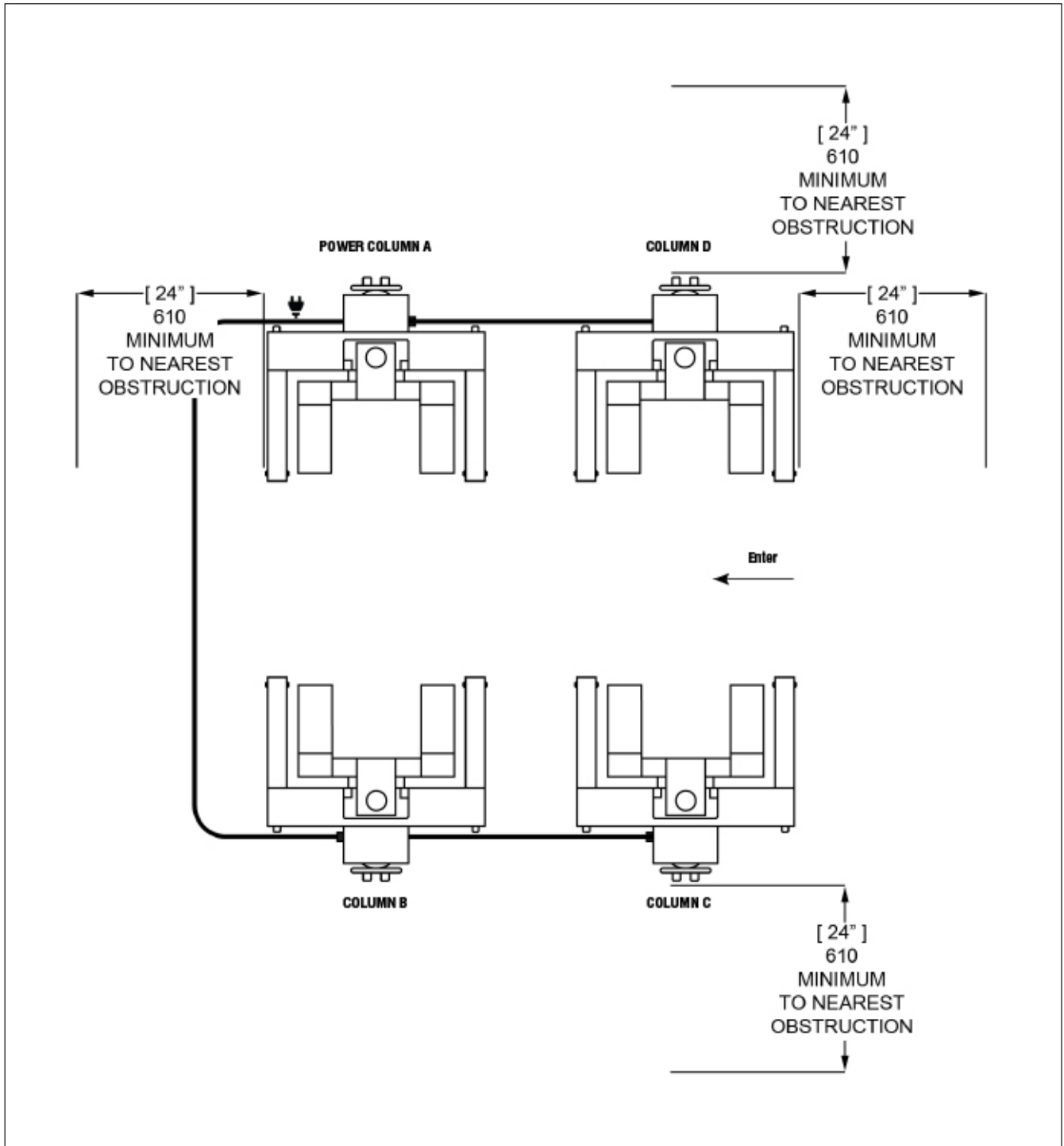

**LIFT HEIGHT CLEARANCE NOTE:** There must be a 148" MIN distance from ground to the nearest overhead obstruction to clear the lift at full rise.

## SECTION 4 (HYDRAULIC JACKING SYSTEM)

The PCL-18B employs a Hydraulic Jacking Dolly System to move and position the Columns. The operation of the Dolly System is similar to that of a pallet Jack. (Fig. 4.1 & 4.2)

### Moving the Columns

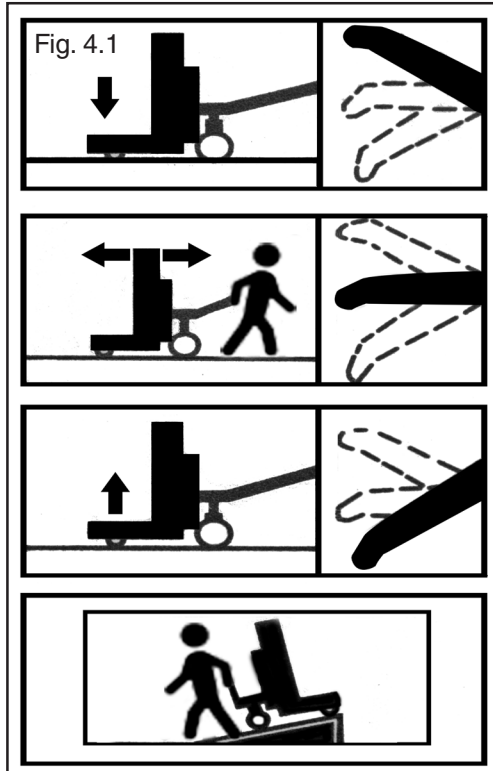

**DO NOT STOP THE JACKING DOLLY ON SLOPE**

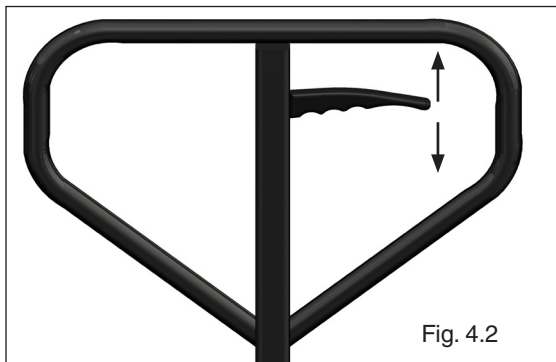

1. Position the Release Handle in the Lowest position.
2. Pump the Handle Bar down and up several times to raise the Column off the ground 1- 1.5" (25-38mm).
3. Position the Release Handle in the middle position.
4. Move the Column Assembly by pushing or pulling on the Handle Bar.
5. When the Column is in the desired location, pull up on the Release Handle and the Column will lower to the ground.



**DO NOT OPERATE THE LIFT WITH THE  
HYDRAULIC JACK IN THE RAISED POSITION.**

**NEVER ATTEMPT TO MOVE A COLUMN WITH A  
VEHICLE LOADED ON THE ARM FORKS.**



**ENSURE THE DOORS OF THE ELECTRIC CONTROL  
BOXES ARE CLOSED TO AVOID GETTING HANDS  
PINCHED OR CRUSHED BY THE HANDLE BAR.**



**ALL LIFTING COLUMNS MUST BE LOWERED TO  
THE GROUND BEFORE LIFTING OF ANY VEHICLE.**

**SECTION 5**  
**(ELECTRICAL CONNECTIONS)**



• ALL WIRING MUST BE PERFORMED BY A LICENSED ELECTRICIAN.

• DO NOT PERFORM ANY MAINTENANCE OR INSTALLATION OF ANY COMPONENTS WITHOUT FIRST ENSURING THAT ELECTRICAL POWER HAS BEEN DISCONNECTED AT THE SOURCE OR PANEL AND CANNOT BE RE-ENERGIZED UNTIL ALL MAINTENANCE AND/OR INSTALLATION PROCEDURES ARE COMPLETED.

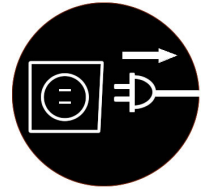

• DO NOT RUN POWER UNIT WITHOUT OIL. DAMAGE TO POWER UNIT PUMP CAN OCCUR. THE POWER UNIT MUST BE KEPT DRY. DAMAGE TO POWER UNIT CAUSED BY WATER OR OTHER LIQUIDS SUCH AS DETERGENTS, ACID ETC., IS NOT COVERED UNDER WARRANTY. OPERATE LIFT ONLY BETWEEN TEMPERATURES OF 41 ° - 104° F. IMPROPER ELECTRICAL HOOK-UP CAN DAMAGE MOTOR AND WILL NOT BE COVERED UNDER WARRANTY. PROTECT EACH CIRCUIT WITH TIME DELAY FUSE OR CIRCUIT BREAKER. FOR 208-230 VOLT, THREE PHASE, USE A 30 AMP FUSE. WHEN SELECTING A PLUG MAKE SURE YOU SELECT A PLUG MADE FOR 30 AMP, 220 VAC, 3 PHASE POWER.

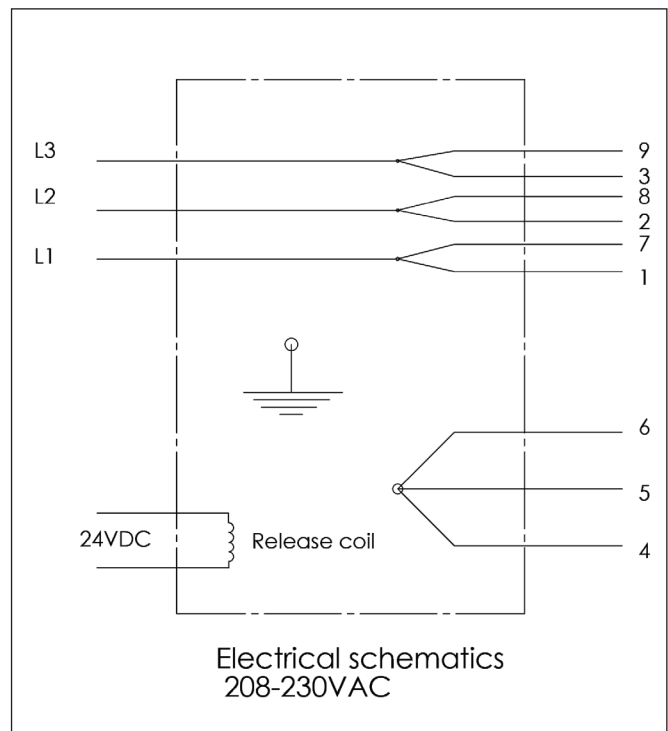
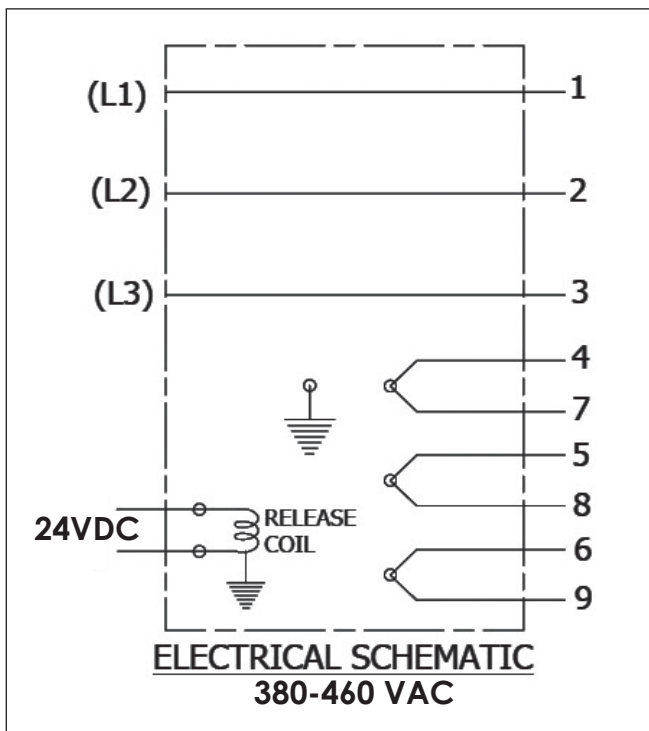

**SECTION 6**  
**(COMMUNICATION CABLE**  
**CONNECTION AND POSITIONING**  
**PROCEDURE)**



**MAIN POWER SWITCH MUST BE OFF BEFORE CONNECTING OR DISCONNECTING ANY OF THE COMMUNICATION CABLES. FAILURE TO FOLLOW PROPER PROCEDURE CAN RESULT IN DAMAGE TO THE ENTIRE CONTROL SYSTEM.**

1. Position each column as shown below. Column A "Master Column" should be located closest to the power supply. (See Fig 6.1)
2. Route and connect the Communication Cables according to the pictures and diagrams below. Pull back on Locking Tab to lock Communication Cable to the Column connectors. (See Fig. 6.2 - 6.4)

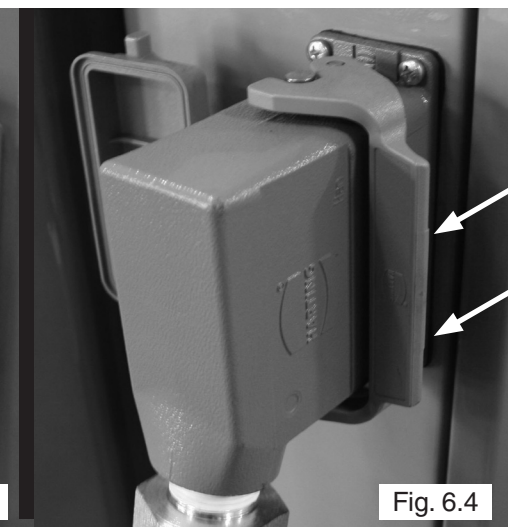
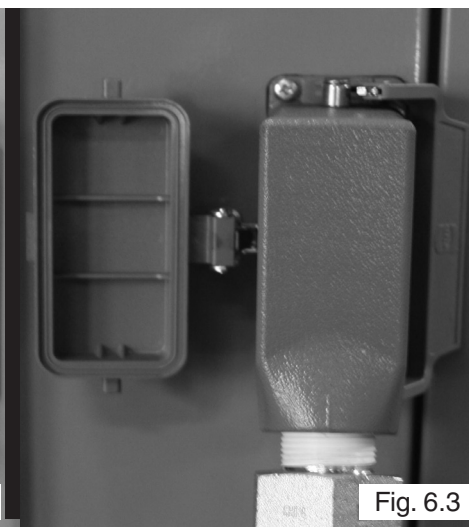
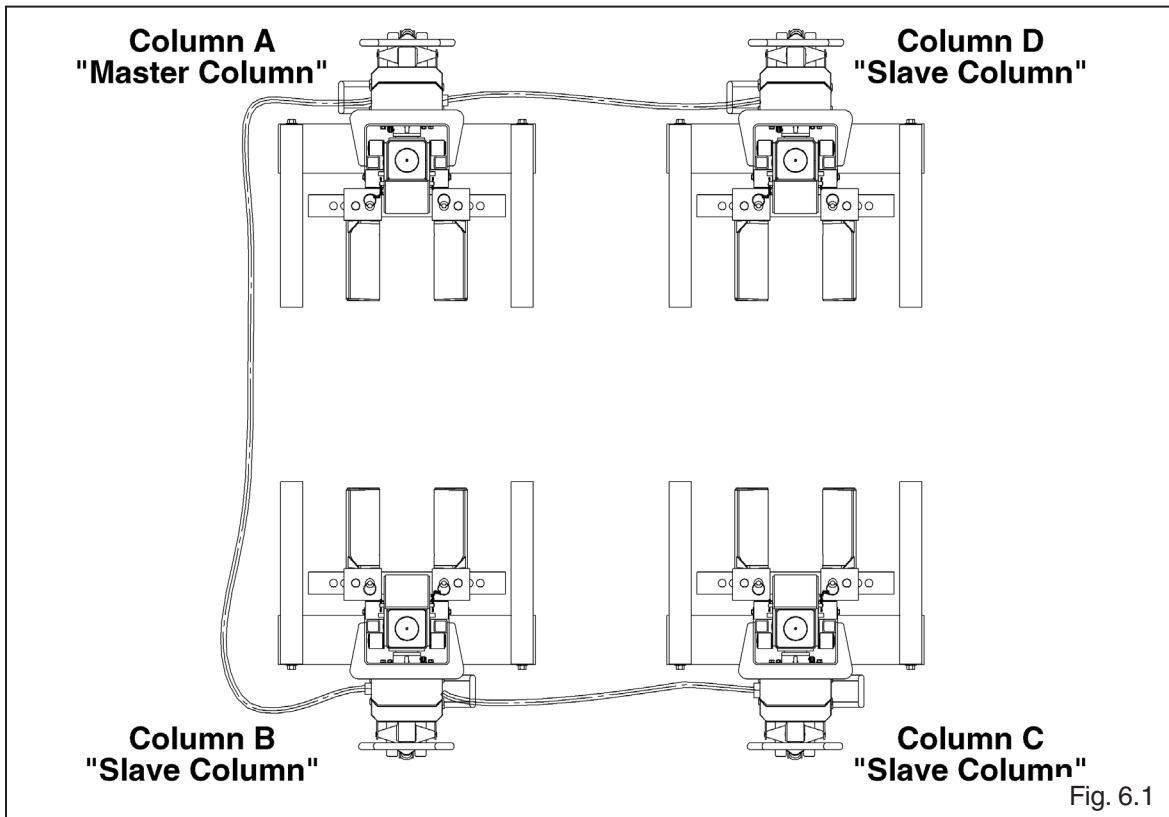

# PCL-18B COLUMN CONFIGURATION

## 2-COLUMN CONFIGURATION

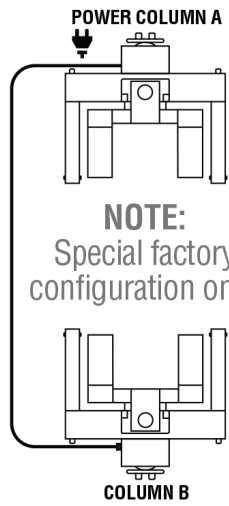

## 4-COLUMN CONFIGURATION

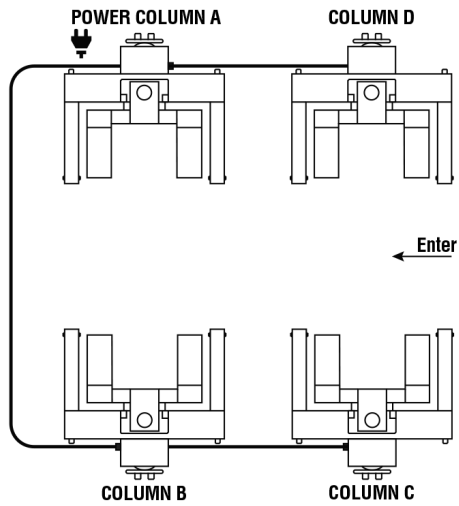

## 6-COLUMN CONFIGURATION

**NOTE:**  
The electrical communication cables do not have to make a complete loop. It is not necessary to plug the last lift back into the first lift. **SEE DIAGRAM**

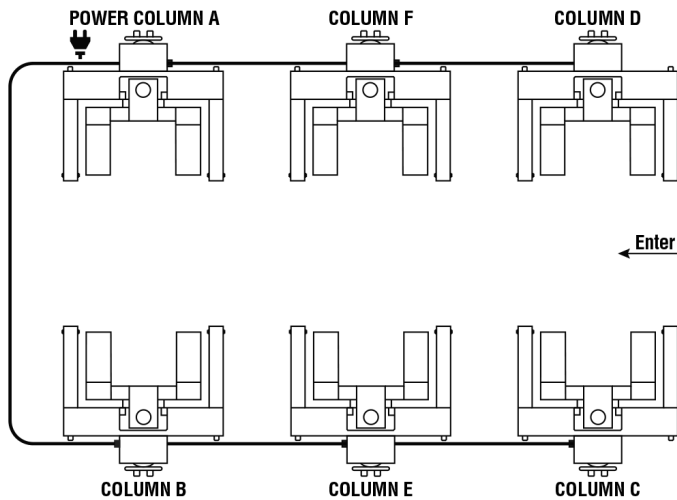

## 8-COLUMN CONFIGURATION

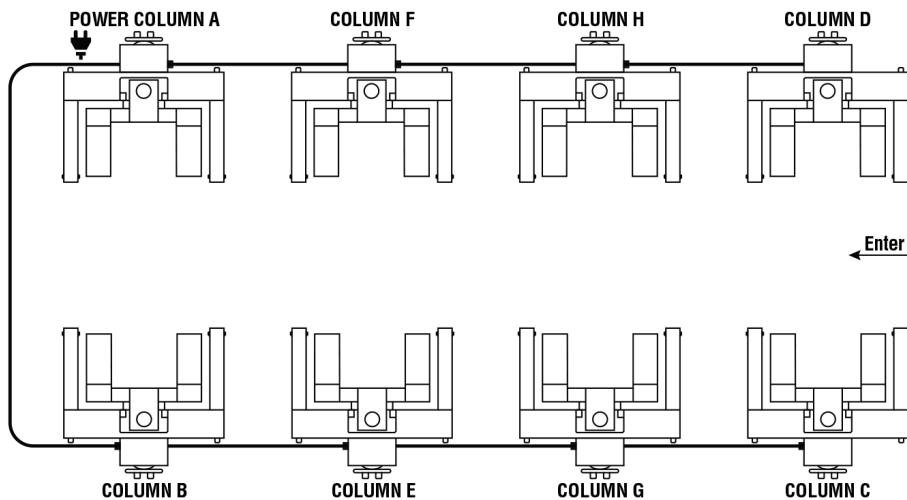

## SECTION 7 CONTROL PANELS

The PCL-18B includes one Master Column (Column A) and Slave Columns (Columns B, C and D). Each Column has a control panel that can operate in SINGLE Mode, the main Column and the one directly across from it in PAIR Mode or all 4 Columns at once in TEAM Mode.

**1. Door Lock** - Prevents unauthorized access to the circuitry of the PCL-18B system. Make sure door is securely closed and locked while the lift is in operation or the columns are being moved. Be sure if the keys are removed that they are kept in a safe place.

**2. UP Control** - Initiates the lift rise sequence.

**3. DOWN Control** - Initiates the lift lowering sequence.

**4. PARK Control** - Initiates the lift locking (parking) sequence. Each lift column will slowly settle onto the mechanical stops.

**5,6,7. TEAM, SINGLE or PAIR LIGHTS**  
Shows which lift columns will operate as group, tandem or individually.

**8. MODE Control** - Commands specific lift columns to operate as single, team and/or pair modes.

**9. SPEED Control** - Selects the parking or lowering speeds.

**10. STANDBY/TURTLE** - Choose this command for a slower "turtle" speed and a safe controlled descent.

**11. READY/RABBIT** - Select the faster "rabbit" speed for a rapid controlled descent.

**12. VISUAL/AUDIBLE ALARM** - When the Main Power switch is moved to the "ON" position, this light will illuminate and the alarm will sound and flash. This alarm will activate whenever the lift is in motion or a fault is detected in the system.

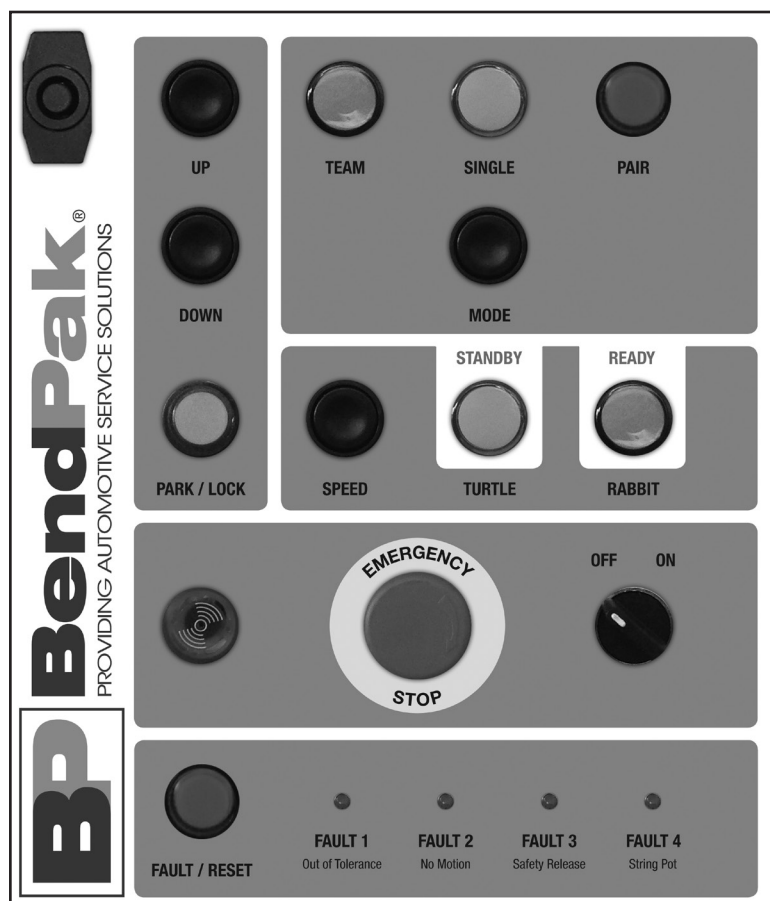

**Master Column Control Panel**

**13. EMERGENCY STOP BUTTON** - Each Column has an Emergency Stop Button. Press this button on any of the Columns when you need to stop operation immediately. To Reset, twist button clockwise. The button will pop back out.

**14. MAIN POWER SWITCH** - Controls power to all of the Columns. When this switch is in the "OFF" position, the lift system is powered off and not operable. When this switch is in the "ON" position, the lift system is powered on and prepared for operation.

**15. FAULT / RESET** - If for any reason the lift operation exceeds a specified out of level tolerance threshold, all lift columns will stop and display the error as: FAULT 1: Out of Tolerance; FAULT 2: No Motion; FAULT 3: Safety Release; FAULT 4: String Pot. To clear the error, an offending lift will be put in SINGLE mode and raised or lowered accordingly to reduce the difference in lift heights.

**16. CALIBRATION BUTTON** - Press and hold this button and in five seconds the calibration procedure will be completed.

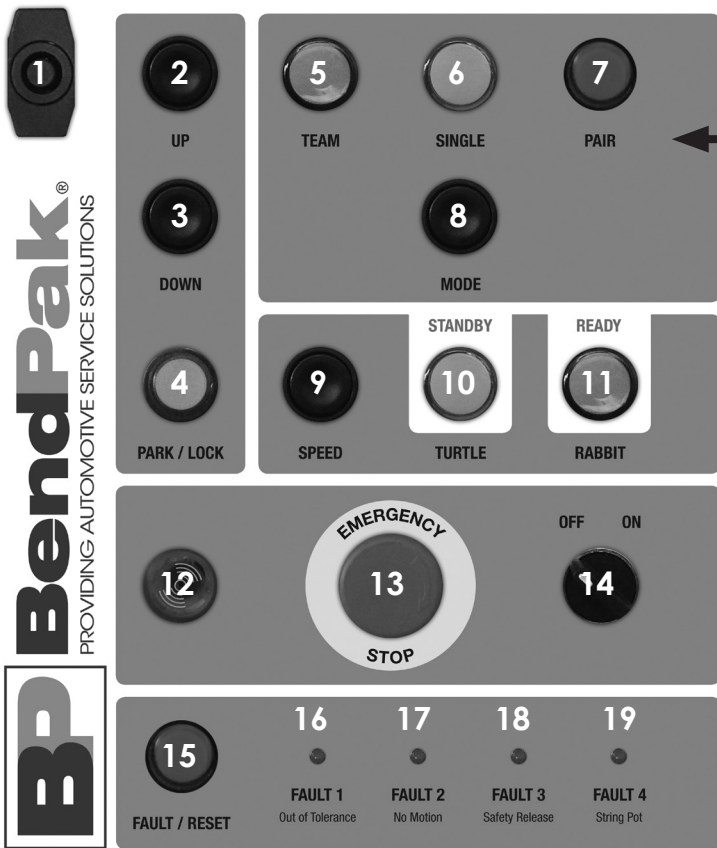

**MASTER COLUMN CONTROL PANEL**

1. Door Lock
2. UP Control
3. DOWN Control
4. PARK Control
5. TEAM Light
6. SINGLE Light
7. PAIR Light
8. MODE Control
9. SPEED Control
10. STANDBY/TURTLE Light
11. READY/RABBIT Light
12. VISUAL/AUDIBLE Alarm
13. EMERGENCY STOP Button
14. MAIN POWER Switch
15. FAULT/RESET button
16. FAULT 1 - Out of Tolerance Light
17. FAULT 2 - No Motion Light
18. FAULT 3 - Safety Release Light
19. FAULT 4 - String Pot Light
20. CALIBRATION Button

**Column A**

**SLAVE COLUMN CONTROL PANELS**

The Columns **B**, **C** and **D** have many of the same features as that of the Column A Control Panel with the following exceptions:

- There is no Power Switch
- There is no Calibration Button
- There is no Main Power Supply Cord to connect to the wall.

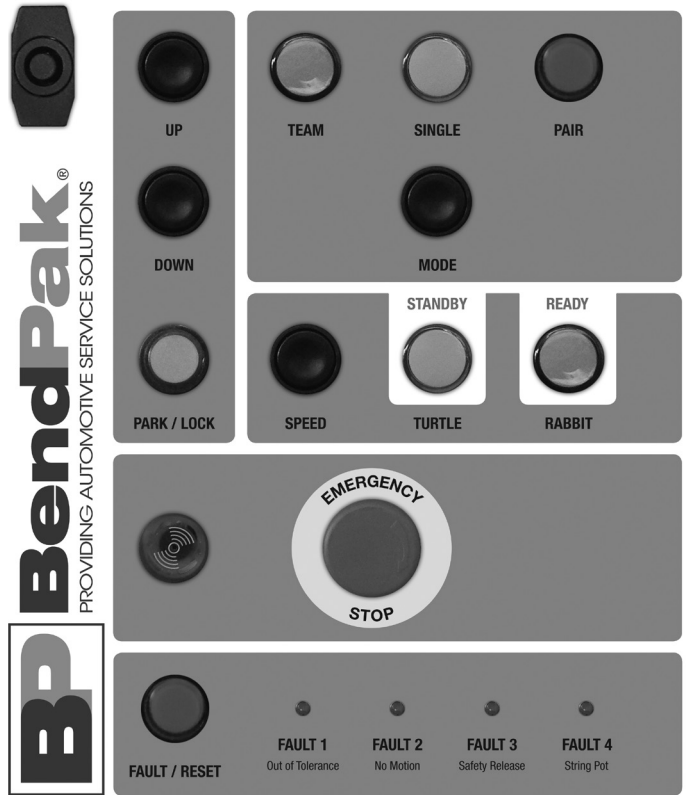

**Columns B, C, D**

## SECTION 8 (INITIAL START-UP AND PLC SYSTEM OVERVIEW)



ENSURE ALL OF THE COLUMNS ARE IN THE LOWERED POSITION AND NOT RESTING ON A RAISED HYDRAULIC JACKING DOLLY.

1. Make sure the power unit reservoirs are full with four (4) gallons of 10-WT hydraulic oil or Dexron-III automatic transmission fluid each.
2. Apply light axle grease to the inside of the posts where the slide blocks glide.
3. Once electrical power is connected to Column A and the communication cables routed to the other Columns, turn the Main Power Switch to the “ON” position. (See Fig. 8.1)

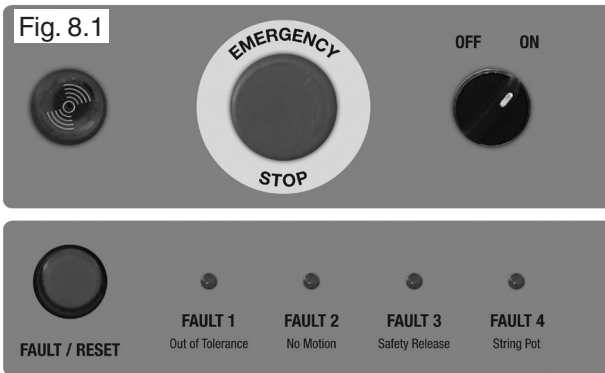

If any of the Column heights are higher than the other one press the “DOWN” button. If the heights still do not match correctly see Maintenance section for calibration instructions.

5. Pressing **MODE** allows the operator to control the movement of the entire system in Team mode (See Fig 8.2), Columns A and B in Pair mode or Column A by itself in Single Mode



6. Pressing **SPEED** allows the operator to change the speed at which the lift will lower when the DOWN button is pressed. Rabbit mode (See Fig. 8.3) allows for a quicker descent while Turtle mode (See Fig 8.4) allows for a slower, more precise descent.

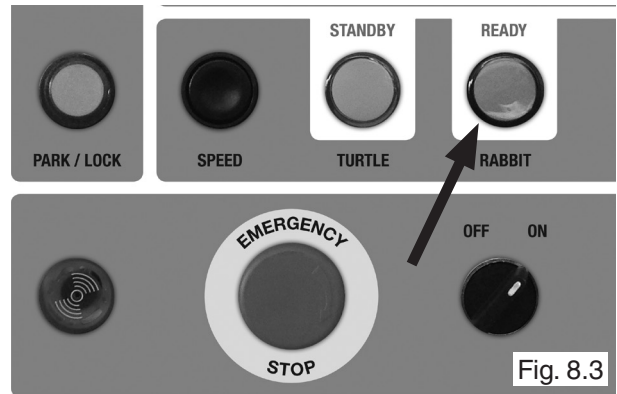

Rabbit Mode

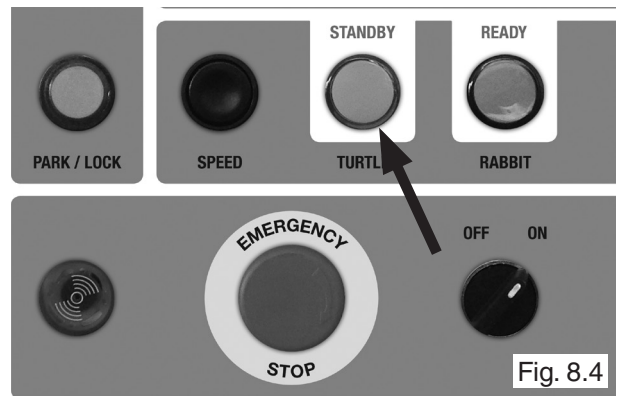

Turtle Mode

7. Pressing **CALIBRATE SYSTEM** (Column A Control Panel only) will set the current height of the lift carriages as the 0 point or ground level. (See Fig 8.5)

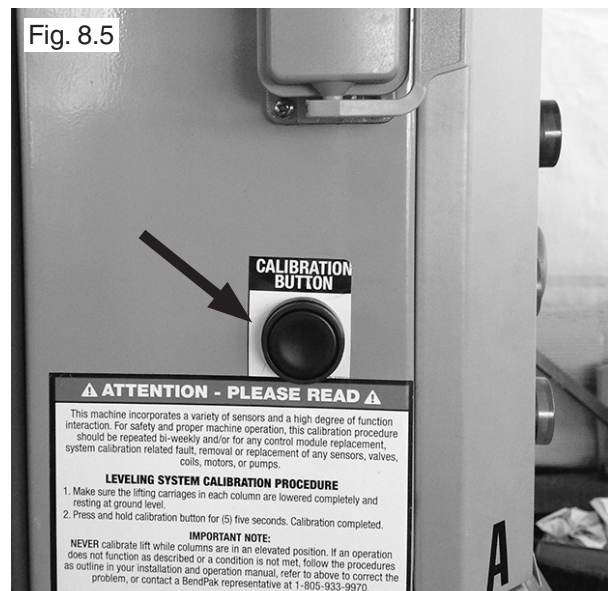

## SECTION 9 (TESTING PROCEDURES)

### Single Column Test

(Repeat these procedures on each Column in Single Mode.)

#### Lifting Test

1. After setting the Operation Mode to SINGLE on the control panel, raise the lift unloaded by pressing and holding the “UP” button to check if the carriage rises normally.

If the Carriage raises slowly or jerks, the Cylinder may have to be bled to release any trapped air in the hydraulic system. If not, go to Step 3.

2. Raise the carriage above about 5”\127mm and loosen the Cylinder Bleed Screw on the top of the Cylinder one full turn or until air or oil flows out. DO NOT completely remove bleed screws. Retighten after trapped air has escaped. (See Fig 9.1)

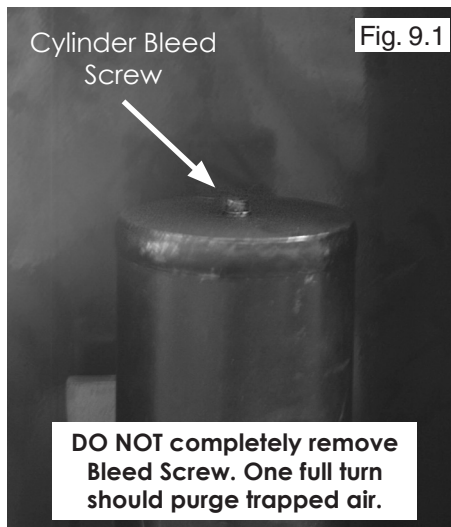

#### Safety and Lowering Test

3. With the Carriage above 21”\533mm press and hold the “PARK” button that became available when the lift passed the indicated height. The lift will lower onto the nearest safety lock. Continue holding the “PARK” button and then check that the Carriage is securely on the safety lock before continuing.

**NOTE: When the PCL-18B is not loaded with a vehicle the SPEED should be set to Rabbit mode or a fault condition may be detected.**

4. Press and hold the “DOWN” button. The carriage will start to move up to clear the safeties and then down to the ground or until the “DOWN” button is released.

#### Emergency Button Test

5. Test the Emergency Stop Button by hitting the Emergency Stop Button while the lift is rising or lowering. The lift should immediately stop. To Reset, twist button clockwise. The button will pop back out.

#### Multiple Column Test

Repeat the Lift Test, Safety Test, Lowering Test, and Emergency Stop Button Test procedure for each of the other Columns in the other Operation Modes: Pair and Team.

#### Remember:

-Pair mode will control the Column directly across from the Column control panel being operated.

-Team mode will control the entire system.

#### POST-INSTALLATION CHECK-OFF

- √ Columns properly lowered and stable.
- √ Wheel and Arm Pins properly attached.
- √ Electric power supply confirmed.
- √ Safety Locks functioning properly.
- √ Check for hydraulic leaks.
- √ Oil level.
- √ Lubrication of critical components.
- √ Check for overhead obstructions.
- √ All Screws, Bolts, and Pins securely fastened.
- √ Surrounding area clean.
- √ Operation, Maintenance and Safety Manuals on site.
- √ Perform an Operational Test with a typical vehicle.

## **SECTION 10 (Operation Instructions)**

### **OWNER/EMPLOYER RESPONSIBILITIES**

#### **The Owner/Employer:**

- Shall ensure that lift operators are qualified and that they are trained in the safe use and operation of the lift using the manufacturer's operating instructions; ALI/SM01-1, ALI Lifting it Right safety manual; ALI/ST-90 ALI Safety Tips card; ANSI/ALI ALOIM-2000, American National Standard for Automotive Lifts-Safety Requirements for Operation, Inspection and Maintenance; ALI/WL Series, ALI Uniform Warning Label Decals/Placards; and in the case of frame engaging lifts, ALI/LP-GUIDE, Vehicle Lifting Points/Quick Reference Guide for Frame Engaging Lifts.
- Shall establish procedures to periodically inspect the lift in accordance with the lift manufacturer's instructions or ANSI/ALI ALOIM-2000, American National Standard for Automotive Lifts-Safety Requirements for Operation, Inspection and Maintenance; and The Employer shall ensure that lift inspectors are qualified and that they are adequately trained in the inspection of the lift.
- Shall establish procedures to periodically maintain the lift in accordance with the lift manufacturer's instructions or ANSI/ALI ALOIM-2000, American National Standard

for Automotive Lifts-Safety Requirements for Operation, Inspection and Maintenance; and The Employer shall ensure that lift maintenance personnel are qualified and that they are adequately trained in the maintenance of the lift.

- Shall maintain the periodic inspection and maintenance records recommended by the manufacturer or ANSI/ALI ALOIM-2000, American National Standard for Automotive Lifts-Safety Requirements for Operation, Inspection and Maintenance.
- Shall display the lift manufacturer's operating instructions; ALI/SM 93-1, ALI Lifting It Right safety manual; ALI/ST-90 ALI Safety Tips card; ANSI/ALI ALOIM-2000, American National Standard for Automotive Lifts-Safety Requirements for Operation, Inspection and Maintenance; and in the case of frame engaging lifts, ALI/LP-GUIDE, Vehicle Lifting Points/Quick Reference Guide for Frame Engaging Lifts; in a conspicuous location in the lift area convenient to the operator.
- Shall provide necessary lockout/tagout means for energy sources per ANSI Z244.1-1982 (R1993), Safety Requirements for the Lockout/Tagout of Energy Sources, before beginning any lift repairs.
- Shall not modify the lift in any manner without the prior written consent of the manufacturer.



## LIFT OPERATION SAFETY

- **DAILY** inspect your lift. Never operate if it malfunctions or if it has broken/damaged parts. Use **only** qualified lift service staff and genuine BendPak parts to make repairs.
- **THOROUGHLY** train all employees in use and care of lift, using manufacturer's instructions and "Lifting It Right" and "Safety Tips" supplied with the lift.
- **NEVER** allow unauthorized or untrained persons to position vehicle or operate lift.
- **PROHIBIT** unauthorized persons from being in shop area while lift is in use.
- **DO NOT** permit anyone on lift or inside vehicle when it is either being raised or lowered.
- **ALWAYS** keep area around lift free of tools, debris, grease and oil.
- **NEVER** overload lift. Capacity of lift is shown on nameplate affixed to the lift.
- **DO NOT** stand in front of the vehicle while it is being positioned in lift bay.
- **DO NOT** hit or run over lift arms, legs or cables. This could damage lift or vehicle. Before driving vehicle into position, move Columns to provide unobstructed access to lift area.
- **ALWAYS** load vehicle on lift carefully. Position the lift arms to contact at the vehicle's wheels. Raise lift until the wheels are 2"/50mm off ground. Check arms for secure contact with wheels. Raise lift to desired working height.
- **DO NOT** block open or override self-closing lift controls; they are designed to return to the "Off" or Neutral position when released.
- **DO NOT** remove or disable arm restraints.
- **ALWAYS** remain clear of lift when raising or lowering vehicles.
- **ALWAYS** use safety stands when removing or installing heavy components.
- **DO NOT** go under raised vehicle if safety locks are not engaged.
- **NEVER LEAVE LIFT IN ELEVATED CONDITION** unless all Safety Locks are engaged.
- **AVOID** excessive rocking of vehicle while on lift.
- **ALWAYS CLEAR AREA** if vehicle is in danger of falling.

- **ALWAYS REMOVE** tool trays, stands, etc. before lowering lift.
- **ALWAYS POSITION** the Columns to provide an unobstructed exit before removing vehicle from lift area.
- **DO NOT** raise or lower the lift with persons or equipment under the vehicle at any time.
- All vehicle tires need to be inspected and properly inflated according to vehicle manufactures specifications.
- **DO NOT** lift any vehicle with any of the tires under inflated, flat, or with any damage or wear that could compromise the load bearing capability of the tire.
- Ensure that all steerable wheels are pointed straight and are parallel to the vehicle body.
- Ensure there is a minimum of 6"/152mm clearance above the top of the vehicle.
- **NEVER** attempt to override any fault condition.
- **DO NOT** operate the lift with any fault condition present.
- **ALWAYS** lower all columns onto the ground after positioning or for storage.
- **DO NOT** apply a horizontal force or load to any raised vehicle that exceeds more than 20% of the vehicles gross weight during any repair procedures.
- Protect the communication cables from damage from sharp objects. **DO NOT** drive over communication cables.
- Calibration procedure should be repeated bi-weekly and/or for any control module replacement, system calibration related fault, removal or replacement of any sensors, valves, coils, motors or pumps.
- **NEVER** calibrate lift whole columns are in an elevated position.
- Read and comply with all safety guidelines and recommendations.

## TO RAISE LIFT

1. Perform the Lift Testing Procedure as outlined in Section 9 before lifting any vehicle.
2. Position the Vehicle on solid concrete surface.
3. Confirm that the vehicles tires are all properly inflated.

**Verify the gross vehicle's weight does not exceed the total capacity of the lifting system.**

4. Adjust the fork arms by removing the Arm Locking Pins and sliding the fork arms so that they are spaced wider than the tire diameter of the vehicle. (See Fig 10.1)

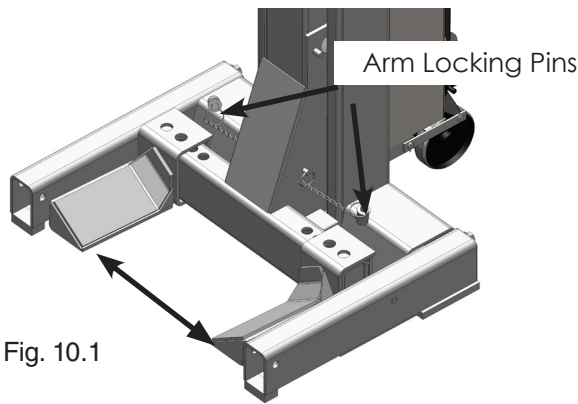

Fig. 10.1

5. Using the Hydraulic Jacking System, position each Column so that the forks of the lift are positioned properly around each of the vehicles wheels. The wheels should be centered between the forks. (See Fig 10.2)

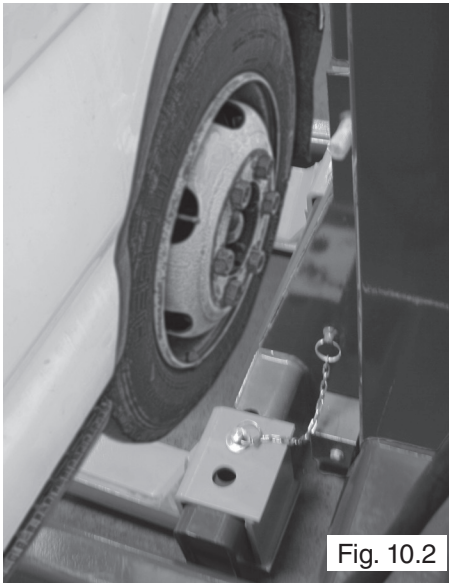

Fig. 10.2



CONFIRM THAT ALL PRIMARY SAFETY LOCKS ARE ENGAGED BEFORE ENTERING WORK AREA. CYLINDER COMPONENTS USED ON THIS LIFT ARE INTENDED TO RAISE AND LOWER LIFT ONLY AND ARE NOT MEANT TO BE LOAD HOLDING DEVICES. REMAIN CLEAR OF ELEVATED LIFT UNLESS CONFIRMATION IS MADE THAT ALL PRIMARY SAFETY LOCKS ARE FULLY ENGAGED AND THE LIFT IS LOWERED ONTO THE SAFETY LOCKS, REFER TO INSTALLATION / OPERATION MANUAL FOR PROPER SAFETY.

6. Lower the Column and adjust the fork arms by pushing the arms until they touch or are as close to the tire as possible. The lift should be parallel to the vehicle body without touching the body or other components of the vehicle. (See Fig 10.3)



Fig. 10.3



WHEN LOWERING THE LIFT PAY CAREFUL ATTENTION THAT ALL PERSONNEL AND OBJECTS ARE KEPT CLEAR. ALWAYS KEEP A VISUAL LINE OF SITE ON THE LIFT AT ALL TIMES. ALWAYS MAKE SURE THAT ALL LOCKS ARE DISENGAGED. IF ONE OF THE LOCKS INADVERTENTLY LOCKS UPON DESCENT THE VEHICLE MAY DISMOUNT CAUSING PERSONAL INJURY OR DEATH.

7. When all the Columns are properly positioned and the clearances around and above the vehicle are clear of obstructions, the Columns can be connected.

8. Keep the Communication Cables clear of sharp objects and foot paths. DO NOT drive over communication cables.

9. Make sure the main Power Switch is in the "OFF" Position.

11. Connect the Master Column to the Power source. Connect Columns to each other. Refer to Section 6 for communication cable routing.

## Raising a Vehicle

12. **START UP:** After connecting the Communication Cables, turn the Main Power Switch located on the Master Column to "ON". First, the amber colored **STANDBY/TURTLE** button will illuminate in **STANDBY** mode then shortly after (approximately six seconds) the green colored **READY/RABBIT** button will illuminate signaling the user that all columns are initialized and ready. The system is now ready to operate.

13. **RAISING ALL WHEELS:** In **TEAM** mode, press any UP button on any column to raise the lift. Keep **UP** button depressed until the vehicle is raised to the desired position. If necessary, use a second person to observe the area not seen by the operator. **NOTE:** While operating the lift, you will observe individual columns slowing down and/or speeding up at various intervals of travel. This is a normal operating characteristic of the system. Always press the **PARK/LOCK** button to lower lift onto the locking latches before entering work area.



TO AVOID PERSONAL INJURY AND/OR PROPERTY DAMAGE, PERMIT ONLY TRAINED PERSONNEL TO OPERATE LIFT. AFTER REVIEWING THESE INSTRUCTIONS, PRACTICE USING LIFT CONTROLS BY RUNNING THE LIFT THROUGH A FEW UNLOADED CYCLES BEFORE LOADING VEHICLE ON LIFT. ALWAYS LIFT THE VEHICLE USING ALL FOUR COLUMNS. NEVER RAISE JUST ONE END, ONE CORNER, OR ONE SIDE OF VEHICLE.



MAIN POWER SWITCH MUST BE OFF BEFORE CONNECTING OR DISCONNECTING ANY OF THE CABLES. FAILURE TO FOLLOW PROPER PROCEDURE CAN RESULT IN DAMAGE TO THE ENTIRE CONTROL SYSTEM.



DO NOT LIFT ANY VEHICLE WITH ANY OF THE TIRES UNDER INFLATED, UN-INFLATED, OR WITH ANY DAMAGE OR WEAR THAT COULD COMPROMISE THE LOAD BEARING CAPABILITY OF THE TIRE.

14. **RAISING PAIRED AXLE:** In **PAIR** mode, press the **UP** button on any **PAIRED** column to raise the desired axle. Keep **UP** button depressed until the vehicle axle is raised to the desired position. Always press the **PARK/LOCK** button to lower lift onto the locking latches before entering the work area. **NOTE:** Be sure that if a set of wheels remains on the ground, they are free to move uninhibited as the distance changes when one pair of wheels is higher or lower than the other pair. Keep the height difference between pairs as low as practical. Under **PAIR** mode, the lift will automatically result in an out-of-level fault if the axle or **PAIRED** column is out of sync by more than 12" height difference between carriages.

15. **RAISING SINGLE WHEEL: SINGLE** operation is to be used only to initially engage the tires and for slight equalization adjustments. An audible alarm will activate at all times during **SINGLE** mode use. To raise only a single wheel, turn the selector switch to **SINGLE** at the post that **SINGLE** control is desired. Press the **UP** button on any paired column to raise the desired wheel. Always press the **PARK/LOCK** button to lower lift onto the locking latches before entering work area.



IMPORTANT NOTE:  
BE VERY CAREFUL WHEN DOING THIS OPERATION THAT THE VEHICLE REMAINS STABLE AND THAT THE SIDE OF THE VEHICLE DOES NOT COME IN CONTACT WITH THE COLUMN.

## Parking on Locks / Lowering Vehicle

1. **PARKING ALL WHEELS (ON MECHANICAL LOCKS):** The **PARK/LOCK** button default is set to lower all selected columns simultaneously onto the mechanical locks. The **PARK/LOCK** button will illuminate identifying that the select lift columns are now **PARK** ready. At this time, press the **PARK/LOCK** button to lower the lift onto the mechanical locks. Keep the **PARK/LOCK** button depressed until the **PARK/LOCK** button light remains off. If necessary, use a second person to observe the area not seen by the operator.



WHEN LOWERING THE LIFT PAY CAREFUL ATTENTION THAT ALL PERSONNEL AND OBJECTS ARE KEPT CLEAR. ALWAYS KEEP A VISUAL LINE OF SITE ON THE LIFT AT ALL TIMES. ALWAYS MAKE SURE THAT ALL LOCKS ARE DISENGAGED. IF ONE OF THE LOCKS INADVERTENTLY LOCKS ON DESCENT THE LIFT AND/OR VEHICLE MAY DISRUPT CAUSING PERSONAL INJURY OR DEATH.

2. **LOWERING LIFT:** Before lowering lift, be sure to remove tool carts, safety stands, etc. from the area and check that all personnel and bystanders remain clear. After ensuring that all columns are initialized and ready, press the DOWN button to lower lift.



**IMPORTANT NOTE:**  
IF THE PARK / LOCK BUTTON HAD BEEN PREVIOUSLY ACTIVATED, THE LIFT WILL AUTOMATICALLY RISE TWO INCHES BEFORE LOWERING COMMENCES.

Observe that all columns are lowering and vehicle remains level. Remain clear of forks and vehicle when lowering and observe all pinch points warnings.  
**NOTE:** The **RABBIT** or **TURTLE** settings can be used to control the lowering speed if desired. Once the vehicle tires have reached the ground, reset the parking brake then move all columns away from the vehicle to provide an unobstructed exit before removing the vehicle. **NEVER** drive vehicle over communication cables.

3. **RESET OPERATION:** During operation, if there is a mechanical or electrical error, a system fault may occur which will cause the lift to stop working. The small fault light indicators on each control panel will help identify the cause. After carefully checking and correcting the fault cause, press the **RESET** button on any column and wait for the fault light indicators to turn off. The lift is then ready to continue operation. Refer to the operation manual for fault conditions, corrections and reset procedures.

### Leveling System Calibration Procedure

1. Make sure the lifting carriages in each column are lowered completely and resting at ground level.
2. Press and hold calibration button for (5) five seconds. Calibration completed.

**IMPORTANT NOTE:** NEVER calibrate lift while columns are in an elevated position.

### MAINTENANCE INSTRUCTIONS



IF YOU ARE NOT COMPLETELY FAMILIAR WITH AUTOMOTIVE LIFT MAINTENANCE PROCEDURES; STOP AND CONTACT THE MANUFACTURER FOR INSTRUCTIONS. TO AVOID PERSONAL INJURY, PERMIT ONLY QUALIFIED PERSONNEL TO PERFORM MAINTENANCE ON THIS EQUIPMENT.

- **Always:** Replace ALL FAULTY PARTS before lift is put back into operation.
- **Always:** Keep bolts tight. Check periodically.
- **Always:** Keep lift components clean.
- **Always:** If oil leakage is observed, call local service representative.
- **Always:** If electrical problems develop, call local service representative.
- **Daily:** Make a visual inspection of ALL MOVING PARTS and check for excessive signs of wear.
- **Daily:** Check safety locks to ensure they are in good operating condition.
- **Weekly:** Lubricate all moving components.
- **Semi-annually:** check fluid level of lift power unit and refill if required per lift installation instructions. We recommend: 10-WT hydraulic oil or Dexron-III automatic transmission fluid.
- **Replace** all caution, warning or safety related decals on the lift if unable to read or missing. Reorder labels from Bendpak.
- Refer to ANSI/ALI ALOIM booklet for periodic inspection checklist and maintenance log sheet.

### Cleaning the Control Panels

- The control panels should be cleaned periodically by wiping it with a lint free damp cloth using a mild soap solution. Dry the surface when finished with a lint free cloth. Do not clean with ammonia based products.

- To prevent damage to the column control panels, avoid touching the outside and inside of the box panel with sharp objects, striking the panel with a hard object, the use of abrasives or using excessive force when pressing the ergonomic push-button controls. In the event that any of the components stop working correctly, they can be replaced. The main system components of this lift are standard off-the shelf brands rather than proprietary printed circuit boards or controls which can be very expensive to service or replace.

### Lubrication

- Raise the lift and Park on the top most safety position.
- Through the top and bottom of each Column, apply a light coat of grease on the frontal face and internal face of the Column Rails. See Figures A & B below.

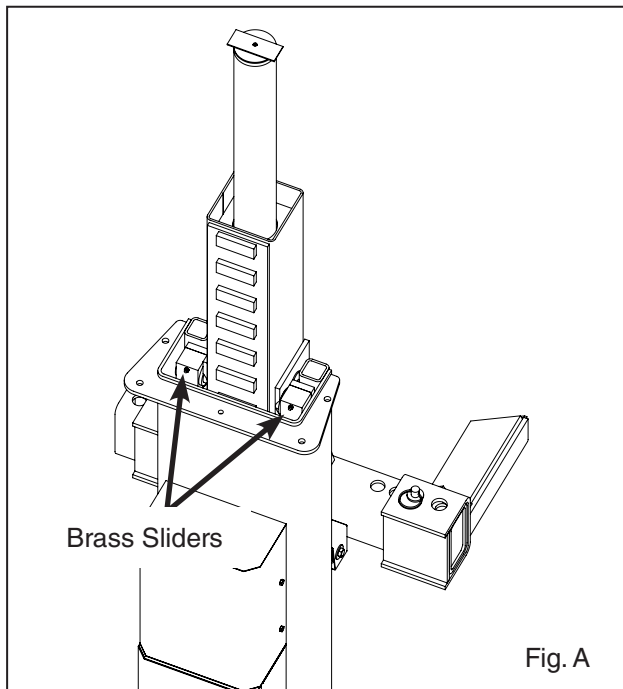

Fig. A

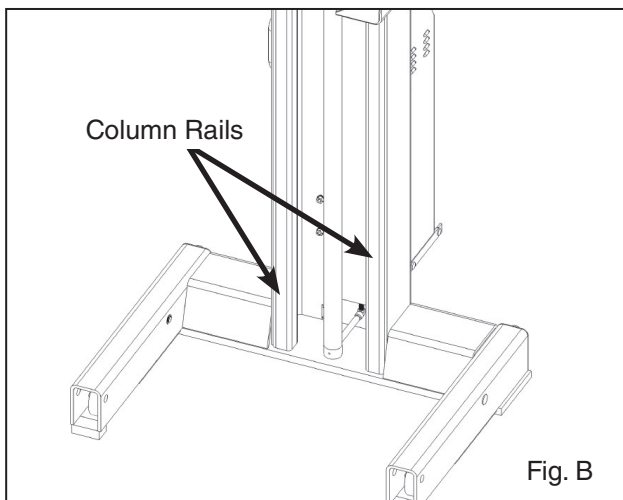

Fig. B

### Bleeding



THE LIFT WILL MOVE DOWN WHEN BLEEDING. MAKE SURE ALL EQUIPMENT, PERSONNEL, HANDS AND FEET ARE CLEAR BEFORE PERFORMING THE CYLINDERS BLEEDING.

1. After electrical power is connected and oil reservoirs are full, press "**UP**" button to raise lift.
2. Continue raising until the fork arms are positioned approximately 36" above floor level.
3. Slowly loosen the BLEED SCREWS, one by one, located at the top of each cylinder to bleed trapped air. DO NOT completely remove bleed screws. Re-tighten after trapped air has escaped. (See Figure below).

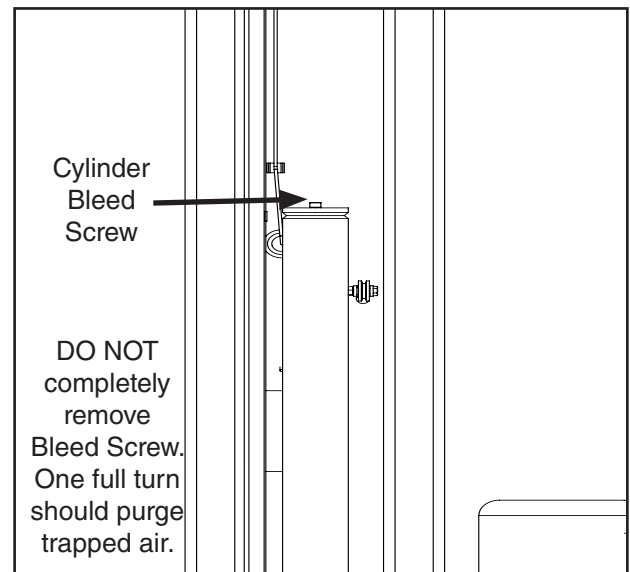

4. Lower the lift completely. Wait five minutes and repeat bleed process one additional time.

FOR TECHNICAL SUPPORT:  
1-800-253-2363 EXT. 196  
TO ORDER PARTS:  
1-800-253-2363 EXT. 191



BENDPAK / RANGER:  
1-805-933-9970

A

**⚠ WARNING** Failure to read, understand and follow these instructions may cause death or serious injury. Read and understand these instructions before using lift.

**RAISING VEHICLE**

- 3-STEP LIFT:** Use the power controls located on the remote control to lift the vehicle. After approximately 10 seconds the green arrow BEMBIT flashes on the remote control. BEMBIT flashes and beeps once the vehicle is raised and ready to use. The system is now ready to operate.
- RAISING ALL WHEELS:** To raise all wheels, press any UP button on any column to raise the lift. Any UP button depressed will raise all wheels to the desired position. If necessary, use the remote control to raise the vehicle. NOTE: When operating the lift, do not allow the vehicle to rise above the maximum height and do not allow it to rise above the maximum height of the lift. This is a safety feature characteristic of the system. After you press the PARK/LOCK button to lower all wheels the vehicle will return to the ready state.
- RAISING SINGLE WHEEL:** To raise one wheel, press the UP button on any PARKED column to raise the desired wheel. Any UP button depressed will raise the vehicle only to the desired height. Press again the PARK/LOCK button to lower the vehicle to the ready state. NOTE: To raise the lift to the desired height, press the UP button on any column to raise the vehicle. NOTE: When operating the lift, do not allow the vehicle to rise above the maximum height and do not allow it to rise above the maximum height of the lift. This is a safety feature characteristic of the system. After you press the PARK/LOCK button to lower all wheels the vehicle will return to the ready state.
- RAISING SINGLE WHEEL:** To raise one wheel, press the UP button on any PARKED column to raise the desired wheel. Any UP button depressed will raise the vehicle only to the desired height. Press again the PARK/LOCK button to lower the vehicle to the ready state. NOTE: To raise the lift to the desired height, press the UP button on any column to raise the vehicle. NOTE: When operating the lift, do not allow the vehicle to rise above the maximum height and do not allow it to rise above the maximum height of the lift. This is a safety feature characteristic of the system. After you press the PARK/LOCK button to lower all wheels the vehicle will return to the ready state.

**PARKING ON LOCKS / LOWERING VEHICLE**

- 3-STEP LIFT:** Press the DOWN button on any PARKED column to lower the vehicle. After approximately 10 seconds the green arrow BEMBIT flashes on the remote control. BEMBIT flashes and beeps once the vehicle is lowered and ready to use. The system is now ready to operate.
- RAISING ALL WHEELS:** To raise all wheels, press any UP button on any column to raise the lift. Any UP button depressed will raise all wheels to the desired position. If necessary, use the remote control to raise the vehicle. NOTE: When operating the lift, do not allow the vehicle to rise above the maximum height and do not allow it to rise above the maximum height of the lift. This is a safety feature characteristic of the system. After you press the PARK/LOCK button to lower all wheels the vehicle will return to the ready state.
- RAISING SINGLE WHEEL:** To raise one wheel, press the UP button on any PARKED column to raise the desired wheel. Any UP button depressed will raise the vehicle only to the desired height. Press again the PARK/LOCK button to lower the vehicle to the ready state. NOTE: To raise the lift to the desired height, press the UP button on any column to raise the vehicle. NOTE: When operating the lift, do not allow the vehicle to rise above the maximum height and do not allow it to rise above the maximum height of the lift. This is a safety feature characteristic of the system. After you press the PARK/LOCK button to lower all wheels the vehicle will return to the ready state.
- RAISING SINGLE WHEEL:** To raise one wheel, press the UP button on any PARKED column to raise the desired wheel. Any UP button depressed will raise the vehicle only to the desired height. Press again the PARK/LOCK button to lower the vehicle to the ready state. NOTE: To raise the lift to the desired height, press the UP button on any column to raise the vehicle. NOTE: When operating the lift, do not allow the vehicle to rise above the maximum height and do not allow it to rise above the maximum height of the lift. This is a safety feature characteristic of the system. After you press the PARK/LOCK button to lower all wheels the vehicle will return to the ready state.

BP BendPak®

1645 Lemoorewood Drive, Brea, CA 92606, U.S.A. 800.955.4870 www.bendpak.com

C

# BENDPAK

**ABOVE-GROUND LIFTS**

BP BendPak®  
ABOVE-GROUND LIFTS

1645 Lemoorewood Drive  
Brea, CA 92606  
U.S.A.  
800.955.4870  
www.bendpak.com

D

**⚠ WARNING**

- ✓ **READ AND UNDERSTAND** all installation and operation instructions as outlined in all manuals thoroughly before installing, operating or servicing this lift.
- ✓ **TRAIN ALL EMPLOYEES** in use of the lift, using manual and "Lifting Right" and "Safety Instructions" supplied with the lift.
- ✓ **NEVER** allow unauthorized or untrained persons to position vehicle/lift or operate lift.
- ✓ **DO NOT USE LIFT** in a manner other than intended. Unapproved uses of the lift include lifting vehicle by only one side, lifting different sides with a column pair (diagonal lifting), and lifting non-approved items or vehicles.
- ✓ **ALWAYS** study lift controls before loading a vehicle onto lift.
- ✓ **NEVER** use on asphalt or soft ground surfaces. Operate lift only on concrete with a minimum strength of 3000 psi and a minimum thickness of 4.5".
- ✓ **MAX ALLOWED FLOOR SLOPE** is 1/8" per foot side to side of vehicle and 1/4" per foot to rear of vehicle.
- ✓ **NEVER** use on a suspended floor without approval from structural engineer.
- ✓ **OBSERVE AND FOLLOW** all safety and warning labels found on the lift and illustrated in the installation and operators manuals.
- ✓ Electrical components on this lift have internal arcing or sparking parts. To minimize the risk of explosion, **DO NOT** expose lift to flammable vapors or operate lift in the vicinity of open containers of flammable liquids.
- ✓ **ALWAYS** ensure tires are properly inflated before lifting. **NEVER** exceed the load rating when raising vehicle.
- ✓ **NEVER** raise lower only one side of a vehicle or vehicle may come in contact with lift columns as vehicle tips.
- ✓ **ALWAYS** lift simultaneously on same side and **NEVER** stagger between sides.
- ✓ **NEVER** drive over or pinch electrical cables.
- ✓ **NEVER** use if electrical cords are in/on water, snow or damp surfaces.
- ✓ This equipment has an operating temperature range of 41°F - 104°F (5° - 40°C).

**⚠ ATTENTION**

- ✓ **LIRE ET COMPRENDRE** toutes les instructions d'installation et d'utilisation décrites dans tous les manuels avant d'installer, d'utiliser ou d'entretenir cet ascenseur.
- ✓ **FORMER TOUS LES EMPLOYÉS** lors de l'utilisation du véhicule. Il s'agit de lire et de comprendre les instructions de levage à deux roues et "Consignes de sécurité" fournies avec le véhicule-personne.
- ✓ **JAMAIS** permettre à des personnes non autorisées ou non formées de positionner le véhicule / l'ascenseur ou d'utiliser l'ascenseur.
- ✓ **NE PAS UTILISER L'ASCENSEUR** d'une manière autre que celle prévue. Les utilisations non approuvées de l'ascenseur comprennent le levage d'un véhicule d'un seul côté, le levage de différents essieux avec une paire de colonnes (levage diagonal) et le levage d'articles ou de véhicules non approuvés.
- ✓ **TOUJOURS** étudier les commandes de levage avant de charger un véhicule sur l'ascenseur.
- ✓ **JAMAIS** utiliser sur asphalte ou sur sol mou. Faire fonctionner l'élevateur uniquement sur du béton ayant une résistance minimale de 21 kg/cm<sup>2</sup> et une épaisseur minimale de 114,5 mm.
- ✓ **PENTE DE SOL MAXI ADMISE** est de 3,2 mm par pied d'un côté à l'autre du véhicule et de 6,4 mm par pied de l'avant à l'arrière du véhicule.
- ✓ **JAMAIS** utiliser sur un plancher suspendu sans l'approbation de l'ingénieur en structure.
- ✓ **OBSERVER ET SUIVRE** toutes les étiquettes de sécurité et d'avertissement présentes sur l'ascenseur et illustrées dans le manuel d'installation et d'utilisation.
- ✓ Les composants électriques de ce pont élévateur comportent des pièces et des intrinsèques d'explosion. Pour minimiser le risque d'explosion, **NE EXPOSEZ PAS** l'ascenseur à des vapeurs inflammables et n'utilisez pas l'ascenseur à proximité de contenueurs ouverts de liquides inflammables.
- ✓ **TOUJOURS** assurez-vous que les pneus sont correctement gonflés avant de les soulever. **NE JAMAIS** dépasser la charge nominale des pneus lors de la montée du véhicule.
- ✓ **JAMAIS** soulever / abaisser un seul côté d'un véhicule ou un véhicule peut entrer en contact avec les colonnes de levage comme parties du véhicule.
- ✓ **TOUJOURS** soulever simultanément sur le même essieu et ne JAMAIS basculer entre les essieux.
- ✓ **JAMAIS** conduire ou pincer les câbles électriques.
- ✓ **JAMAIS** utiliser si les cordons électriques sont dans l'eau, la neige ou des surfaces humides.
- ✓ Cet équipement a une plage de températures de fonctionnement de 41° F - 104° F (5° - 40° C).

B

**⚠ WARNING** Failure to read, understand and follow these instructions may cause death or serious injury. Read and understand these instructions before using lift.

**RAISING VEHICLE**

- 3-STEP LIFT:** Use the power controls located on the remote control to lift the vehicle. After approximately 10 seconds the green arrow BEMBIT flashes on the remote control. BEMBIT flashes and beeps once the vehicle is raised and ready to use. The system is now ready to operate.
- RAISING ALL WHEELS:** To raise all wheels, press any UP button on any column to raise the lift. Any UP button depressed will raise all wheels to the desired position. If necessary, use the remote control to raise the vehicle. NOTE: When operating the lift, do not allow the vehicle to rise above the maximum height and do not allow it to rise above the maximum height of the lift. This is a safety feature characteristic of the system. After you press the PARK/LOCK button to lower all wheels the vehicle will return to the ready state.
- RAISING SINGLE WHEEL:** To raise one wheel, press the UP button on any PARKED column to raise the desired wheel. Any UP button depressed will raise the vehicle only to the desired height. Press again the PARK/LOCK button to lower the vehicle to the ready state. NOTE: To raise the lift to the desired height, press the UP button on any column to raise the vehicle. NOTE: When operating the lift, do not allow the vehicle to rise above the maximum height and do not allow it to rise above the maximum height of the lift. This is a safety feature characteristic of the system. After you press the PARK/LOCK button to lower all wheels the vehicle will return to the ready state.
- RAISING SINGLE WHEEL:** To raise one wheel, press the UP button on any PARKED column to raise the desired wheel. Any UP button depressed will raise the vehicle only to the desired height. Press again the PARK/LOCK button to lower the vehicle to the ready state. NOTE: To raise the lift to the desired height, press the UP button on any column to raise the vehicle. NOTE: When operating the lift, do not allow the vehicle to rise above the maximum height and do not allow it to rise above the maximum height of the lift. This is a safety feature characteristic of the system. After you press the PARK/LOCK button to lower all wheels the vehicle will return to the ready state.

**PARKING ON LOCKS / LOWERING VEHICLE**

- 3-STEP LIFT:** Press the DOWN button on any PARKED column to lower the vehicle. After approximately 10 seconds the green arrow BEMBIT flashes on the remote control. BEMBIT flashes and beeps once the vehicle is lowered and ready to use. The system is now ready to operate.
- RAISING ALL WHEELS:** To raise all wheels, press any UP button on any column to raise the lift. Any UP button depressed will raise all wheels to the desired position. If necessary, use the remote control to raise the vehicle. NOTE: When operating the lift, do not allow the vehicle to rise above the maximum height and do not allow it to rise above the maximum height of the lift. This is a safety feature characteristic of the system. After you press the PARK/LOCK button to lower all wheels the vehicle will return to the ready state.
- RAISING SINGLE WHEEL:** To raise one wheel, press the UP button on any PARKED column to raise the desired wheel. Any UP button depressed will raise the vehicle only to the desired height. Press again the PARK/LOCK button to lower the vehicle to the ready state. NOTE: To raise the lift to the desired height, press the UP button on any column to raise the vehicle. NOTE: When operating the lift, do not allow the vehicle to rise above the maximum height and do not allow it to rise above the maximum height of the lift. This is a safety feature characteristic of the system. After you press the PARK/LOCK button to lower all wheels the vehicle will return to the ready state.
- RAISING SINGLE WHEEL:** To raise one wheel, press the UP button on any PARKED column to raise the desired wheel. Any UP button depressed will raise the vehicle only to the desired height. Press again the PARK/LOCK button to lower the vehicle to the ready state. NOTE: To raise the lift to the desired height, press the UP button on any column to raise the vehicle. NOTE: When operating the lift, do not allow the vehicle to rise above the maximum height and do not allow it to rise above the maximum height of the lift. This is a safety feature characteristic of the system. After you press the PARK/LOCK button to lower all wheels the vehicle will return to the ready state.

BP BendPak®

1645 Lemoorewood Drive, Brea, CA 92606, U.S.A. 800.955.4870 www.bendpak.com

**2-COLUMN CONFIGURATION / CONFIGURATION A 2 COLONNES**

**4-COLUMN CONFIGURATION / CONFIGURATION A 4 COLONNES**

**6-COLUMN CONFIGURATION / CONFIGURATION A 6 COLONNES**

**8-COLUMN CONFIGURATION / CONFIGURATION A 8 COLONNES**

**NOTE:** The electrical communication cables do not have to make a complete loop. It is not necessary to plug the last lift back into the first lift. SEE DIAGRAM.

**REMARQUE:** L'électricité la communication les câbles ne dois faire un boucle complète. Il n'est pas nécessaire de brancher le dernier ascenseur dans le premier ascenseur. VOIR DIAGRAMME.

PAR506565

# E

**⚠ ATTENTION ⚠**

**MAXIMUM LIFTING CAPACITY**  
**CAPACITÉ DE LEVAGE MAXIMUM**

**18000 Lbs.**  
**8165 Kg.**

PN 5905675

# F

**CALIBRATION  
BUTTON**

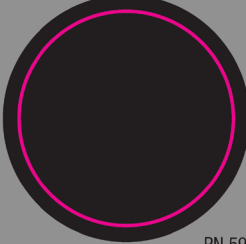

PN 5905622

# G

**⚠ ATTENTION - PLEASE READ ⚠**

This machine incorporates a variety of sensors and a high degree of function interaction. For safety and proper machine operation, this calibration procedure should be repeated bi-weekly and/or for any control module replacement, system calibration related fault, removal or replacement of any sensors, valves, coils, motors, or pumps.

**LEVELING SYSTEM CALIBRATION PROCEDURE**

1. Make sure the lifting carriages in each column are lowered completely and resting at ground level.
2. Press and hold calibration button for (5) five seconds. Calibration completed.

**IMPORTANT NOTE:**  
Never calibrate lift while columns are in an elevated position. If an operation does not function as described or a condition is not met, follow the procedures as outline in your installation and operation manual, refer to above to correct the problem, or contact a BendPak representative at 1-805-933-9970.

**⚠ ATTENTION - VEUILLEZ LIRE ⚠**

Cette machine intègre une variété de capteurs et un degré élevé d'interaction fonctionnelle. Pour la sécurité et le bon fonctionnement de la machine, cette procédure d'étalonnage doit être répétée toutes les deux semaines et / ou pour tout remplacement de module de commande, défaut lié à l'étalonnage du système, retrait ou remplacement de tous capteurs, vannes, bobines, moteurs ou pompes.

**PROCÉDURE D'ÉTALONNAGE DU SYSTÈME DE MISE À NIVEAU**

1. Assurez-vous que les chariots élévateurs de chaque colonne sont complètement abaissés et reposent au niveau du sol.
2. Appuyez et maintenez enfoncé le bouton d'étalonnage pendant (5) cinq secondes. L'étalonnage est terminé.

**NOTE IMPORTANTE:**  
Ne jamais calibrer la portance lorsque les colonnes sont en position élevée. Si une opération ne fonctionne pas comme décrit ou si une condition n'est pas remplie, suivez les procédures décrites dans votre manuel d'installation et d'utilisation, reportez-vous ci-dessus pour corriger le problème ou contactez un représentant BendPak au 1-805-933-9970.

PN 5905621

# H

<b>⚠ WARNING</b>  Clear area if vehicle is in danger of falling.	<b>⚠ WARNING</b>  Remain clear of lift when raising or lowering vehicle.	<b>NOTICE</b>  Read operating and safety manuals before using lift.	<b>NOTICE</b>  Proper maintenance and inspection is necessary for safe operation.
<b>⚠ WARNING</b>  Locate lift on firm, level surface, preferably concrete.	<b>⚠ WARNING</b>  Be sure intended lifts are moving together evenly.	<b>NOTICE</b>  Do not operate a damaged lift.	<p>The messages and pictographs shown are generic in nature and are meant to generally represent hazards common to all automotive lifts regardless of specific style.</p> <p>Funding for the development and validation of these labels was provided by the Automotive Lift Institute, PO Box 85 Cortland, NY 13045.</p> <p>Replacement label sets may be obtained from the original lift manufacturer and ALI's member companies. They are protected by copyright.</p> <p><a href="http://www.autolift.org">www.autolift.org</a></p> <p>© 2012 by ALL Inc. ALIWL400a</p>
<b>⚠ WARNING</b>  All lifting forks must properly engage vehicle tires or supports.	<b>⚠ WARNING</b>  Do not drive over or pinch electrical cables.	<b>⚠ CAUTION</b>  Lift to be used by trained operator only.	
<b>⚠ WARNING</b>  Keep feet clear of lift while lowering.	<p>The messages and pictographs shown are generic in nature and are meant to generally represent hazards common to all automotive lifts regardless of specific style.</p> <p>Funding for the development and validation of these labels was provided by the Automotive Lift Institute, PO Box 85 Cortland, NY 13045.</p> <p>Replacement label sets may be obtained from the original lift manufacturer and ALI's member companies. They are protected by copyright.</p> <p><a href="http://www.autolift.org">www.autolift.org</a></p> <p>© 2012 by ALL Inc. ALIWL400a</p>	<b>⚠ CAUTION</b>  When moving lift, be careful to avoid tipping.	<b>⚠ CAUTION</b>  Check for overhead obstructions before raising vehicle.
<p>The messages and pictographs shown are generic in nature and are meant to generally represent hazards common to all automotive lifts regardless of specific style.</p> <p>Funding for the development and validation of these labels was provided by the Automotive Lift Institute, PO Box 85 Cortland, NY 13045.</p> <p>Replacement label sets may be obtained from the original lift manufacturer and ALI's member companies. They are protected by copyright.</p> <p><a href="http://www.autolift.org">www.autolift.org</a></p> <p>© 2012 by ALL Inc. ALIWL400a</p>			

# I

**CERTIFIED AUTOMOTIVE LIFT**

**INDEPENDENTLY TESTED  
ALI  
CERTIFIED  
AND VALIDATED**

**ALI CERTIFIED**  
To the provisions of  
**ANSI/ALI ALCTV-2017**  
SAFETY REQUIREMENTS FOR  
CONSTRUCTION, TESTING  
AND VALIDATION

Automotive Lift Institute, Inc. | Cortland, NY 13045

**MET LISTED**  
Conforms to  
**ANSI/UL 201**  
SAFETY STANDARD FOR  
GARAGE EQUIPMENT

**MET** LISTED  
**MET**®  
MET Laboratories, Inc.  
BALTIMORE, MD 21230

Certification Label Serial Number



ALXXSAMPLEXXN

# Column Indicator Labels

## Primary Column

<b>COLUMN</b> <b>A</b> <b>COLONNE</b>	<b>⚠ CAUTION</b> Main power switch must be off before connecting or disconnecting any of the communication cables. Failure to follow proper procedure can result in damage to the entire control system.
	<b>⚠ MISE EN GARDE</b> L'interrupteur principal doit être éteint avant de connecter ou de déconnecter l'un des câbles de communication. Le non-respect de la procédure appropriée peut endommager l'ensemble du système de commande.

PH 5905475

## Secondary Columns

<b>COLUMN</b> <b>B</b> <b>COLONNE</b>	<b>⚠ CAUTION</b> Main power switch must be off before connecting or disconnecting any of the communication cables. Failure to follow proper procedure can result in damage to the entire control system.
	<b>⚠ MISE EN GARDE</b> L'interrupteur principal doit être éteint avant de connecter ou de déconnecter l'un des câbles de communication. Le non-respect de la procédure appropriée peut endommager l'ensemble du système de commande.

PH 5905580

<b>COLUMN</b> <b>C</b> <b>COLONNE</b>	<b>⚠ CAUTION</b> Main power switch must be off before connecting or disconnecting any of the communication cables. Failure to follow proper procedure can result in damage to the entire control system.
	<b>⚠ MISE EN GARDE</b> L'interrupteur principal doit être éteint avant de connecter ou de déconnecter l'un des câbles de communication. Le non-respect de la procédure appropriée peut endommager l'ensemble du système de commande.

PH 5905595

<b>COLUMN</b> <b>D</b> <b>COLONNE</b>	<b>⚠ CAUTION</b> Main power switch must be off before connecting or disconnecting any of the communication cables. Failure to follow proper procedure can result in damage to the entire control system.
	<b>⚠ MISE EN GARDE</b> L'interrupteur principal doit être éteint avant de connecter ou de déconnecter l'un des câbles de communication. Le non-respect de la procédure appropriée peut endommager l'ensemble du système de commande.

PH 5906020

## Optional for 6 and 8 Column Configurations

<b>COLUMN</b> <b>E</b> <b>COLONNE</b>	<b>⚠ CAUTION</b> Main power switch must be off before connecting or disconnecting any of the communication cables. Failure to follow proper procedure can result in damage to the entire control system.
	<b>⚠ MISE EN GARDE</b> L'interrupteur principal doit être éteint avant de connecter ou de déconnecter l'un des câbles de communication. Le non-respect de la procédure appropriée peut endommager l'ensemble du système de commande.

PH 5906117

<b>COLUMN</b> <b>F</b> <b>COLONNE</b>	<b>⚠ CAUTION</b> Main power switch must be off before connecting or disconnecting any of the communication cables. Failure to follow proper procedure can result in damage to the entire control system.
	<b>⚠ MISE EN GARDE</b> L'interrupteur principal doit être éteint avant de connecter ou de déconnecter l'un des câbles de communication. Le non-respect de la procédure appropriée peut endommager l'ensemble du système de commande.

PH 5905815

<b>COLUMN</b> <b>G</b> <b>COLONNE</b>	<b>⚠ CAUTION</b> Main power switch must be off before connecting or disconnecting any of the communication cables. Failure to follow proper procedure can result in damage to the entire control system.
	<b>⚠ MISE EN GARDE</b> L'interrupteur principal doit être éteint avant de connecter ou de déconnecter l'un des câbles de communication. Le non-respect de la procédure appropriée peut endommager l'ensemble du système de commande.

PH 5905816

<b>COLUMN</b> <b>H</b> <b>COLONNE</b>	<b>⚠ CAUTION</b> Main power switch must be off before connecting or disconnecting any of the communication cables. Failure to follow proper procedure can result in damage to the entire control system.
	<b>⚠ MISE EN GARDE</b> L'interrupteur principal doit être éteint avant de connecter ou de déconnecter l'un des câbles de communication. Le non-respect de la procédure appropriée peut endommager l'ensemble du système de commande.

PH 5905816



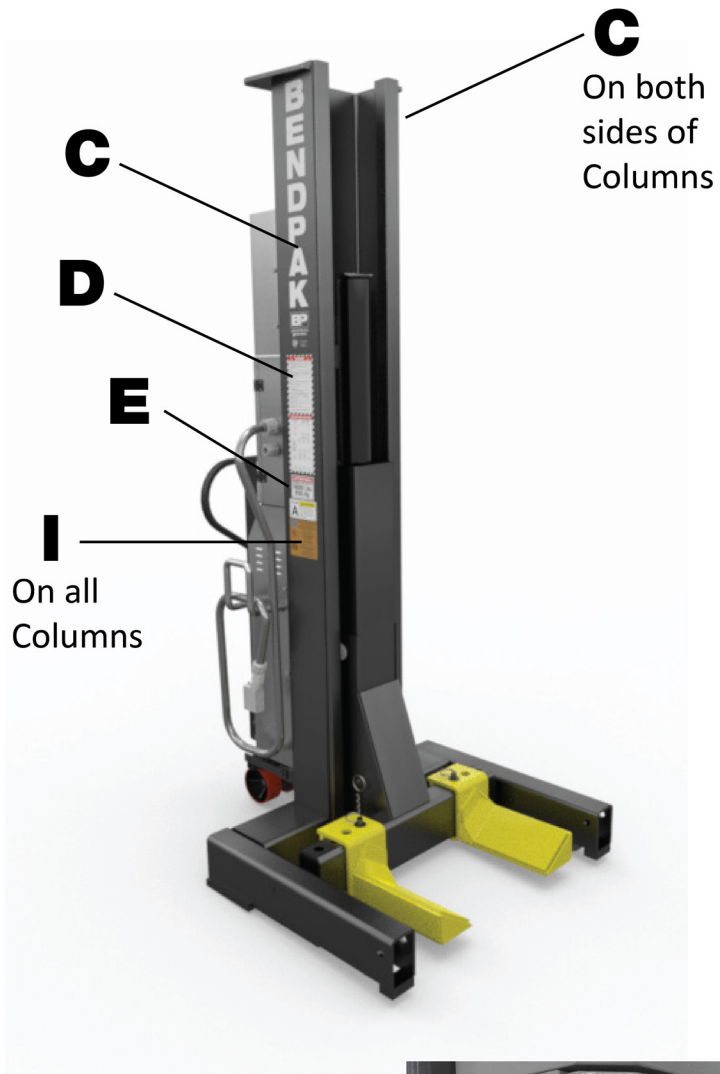

**A**

## Primary Control Panel

Use on Column A *only*

**B**

## Secondary Control Panel

Use on Columns B, C, D, E, F, G, H

## Safe Lift Operation

Automotive and truck lifts are critical to the operation and profitability of your business. The safe use of this and other lifts in your shop is critical in preventing employee injuries and damage to customer's vehicles. Safe operation of automotive lifts requires that only trained employees should be allowed to use the lift.

### **TRAINING SHOULD INCLUDE, BUT NOT BE LIMITED TO:**

- ◆ Proper positioning of the columns with respect to the vehicle.
- ◆ Use of the operating controls.
- ◆ Understanding the lift capacity.
- ◆ Proper use of jack stands or other load supporting devices.
- ◆ Proper use, understanding and visual identification of safety lock devices and their operation.
- ◆ Reviewing the safety rules.
- ◆ Proper housekeeping procedures. (Lift area should be free of grease, oil, tools, equipment, trash, and other debris.)
- ◆ A daily inspection of the lift should be completed prior to its use. Safety devices, operating controls, lift arms and other critical parts should be inspected prior to using the lift.
- ◆ All maintenance and repairs of the lift should be completed by following the manufacturer's requirements. Lift repair parts should meet or exceed OEM specifications. Repairs should only be completed by a qualified lift technician.
- ◆ The vehicle manufacturer's recommendations should be used for spotting and lifting the vehicle.

### **LIFT OPERATION SAFETY**

- ◆ It is important that you know the load limit. Be careful that you do not overload the lift. If you are unsure what the load limit is, check the data plate found on one of the lift columns or contact the manufacturer.
- ◆ Always make sure you have proper overhead clearance. Additionally, check that attachments, (vehicle signs, campers, antennas, etc.) are not in the way.
- ◆ Be sure that prior to the vehicle being raised, the doors, trunk, and hood are closed securely.
- ◆ Prior to being raised, make sure there is no one standing closer than six feet from the lift.
- ◆ After positioning the columns on the vehicle, set the emergency brake, make sure the ignition is off, the doors are closed, and overhead obstructions are cleared.
- ◆ Double check that the wheel forks are in position and then when the lift is raised observe the forks.
- ◆ Put pads or adapters in the right position under the contact points that have been recommended.
- ◆ The lift should be raised just until the vehicle's wheels are about one foot off the ground. If contact with the vehicle is uneven or it appears that the vehicle is not sitting secure, carefully lower the lift and readjust.
- ◆ Always consider potential problems that might cause a vehicle to slip, i.e., heavy cargo, undercoating, etc.
- ◆ Pay attention when walking under a vehicle that is up on the hydraulic lift.



- ◆ **DO NOT** leave the controls while the lift is still in motion.
- ◆ **DO NOT** stand directly in front of the vehicle or in the bay when vehicle is being loaded or driven into position.
- ◆ **DO NOT** go near vehicle or attempt to work on the vehicle when being raised or lowered.
- ◆ **REMAIN CLEAR** of lift when raising or lowering vehicle.
- ◆ **DO NOT** rock the vehicle while on the lift or remove any heavy component from vehicle that may cause excessive weight shift.
- ◆ **DO NOT** lower the vehicle until people, materials, and tools are clear. Always lower vehicle down slowly and smoothly.
- ◆ **ALWAYS ENSURE** that the safeties are engaged and carriages are lowered on to the safeties before any attempt is made to work on or near vehicle.
- ◆ Some vehicle maintenance and repair activities may cause the vehicle to shift. Follow the manufacturer's guidelines when performing these operations. The use of jack stands or alternate lift points may be required when completing some repairs.
- ◆ **READ AND UNDERSTAND** all safety warning procedures before operating lift.
- ◆ **KEEP HANDS AND FEET CLEAR.** Remove hands and feet from any moving parts. Keep feet clear of lift when lowering. Avoid pinch points.
- ◆ **ONLY TRAINED OPERATORS** should operate this lift. All non-trained personnel should be kept away from work area. Never let non-trained personnel come in contact with, or operate lift.
- ◆ **USE LIFT CORRECTLY.** Use lift in the proper manner. Never use lifting adapters other than what is approved by the manufacturer.
- ◆ **DO NOT** override self-closing lift controls.
- ◆ **CLEAR AREA** if vehicle is on danger of falling.
- ◆ **STAY ALERT.** Watch what you are doing. Use common sense. Be aware.
- ◆ **CHECK FOR DAMAGED PARTS.** Check for alignment of moving parts, breakage of parts or any condition that may affect its operation. Do not use lift if any component is broken or damaged.
- ◆ **NEVER** remove safety related components from the lift. Do not use lift if safety related components are damaged or missing.
- ◆ **NEVER** calibrate lift while columns are in an elevated position.
- ◆ When the lift is being lowered, make sure everyone is standing at least six feet away.
- ◆ Be sure there are no jacks, tools, equipment, left under the lift before lowering.

# LIFT WILL NOT RAISE

## POSSIBLE CAUSE

1. Air in oil, (1,2,6,11)
2. Cylinder binding, (7)
3. Cylinder leaks internally, (7)
4. Motor run backward under pressure, (9)
5. Lowering valve leaks, (3,8,9)
6. Motor runs backwards, (5,9,12)
7. Pump damaged, (8,9)
8. Pump won't prime, (1,6,8,9,10,11,12)
9. Relief valve leaks, (8,9)
10. Voltage to motor incorrect, (5,9,12)

## REMEDY

- | REMEDY  | INSTRUCTION  |
|---|--|
| 1. Check for proper oil level. . . . .              | The oil level should be up to the FILL screw in the reservoir with the lift all the way down.  |
| 2. Bleed cylinders. . . . .                         | See Installation Manual.   |
| 3. Dirty oil . . . . .                              | Use clean 10-WT hydraulic oil or Dexron-III automatic transmission fluid only. If fluid/oil is contaminated, replace with clean fluid/oil and clean entire system. |
| 4. Tighten all fasteners. . . . .                   | Tighten fasteners to recommended torques.  |
| 5. Check motor is wired correctly. . . . .          | Compare wiring of motor to electrical diagram on drawing.  |
| 6. Oil seal damaged or crooked . . . . .            | Replace oil seal around pump shaft.  |
| 7. See Installation Manual . . . . .                | Consult Lift Manufacturer.   |
| 8. Replace with new part . . . . .                  | Replace with new part.   |
| 9. Return unit for repair . . . . .                 | Return unit for repair.  |
| 10. Check pump-mounting bolts . . . . .             | Bolts should be 15 to 18 ft. lbs.  |
| 11. Inlet screen clogged . . . . .                  | Clean inlet screen or replace.   |
| 12. Check wall outlet voltages and wiring . . . . . | Make sure unit and wall outlet are wired properly.   |

OUR LIFTS ARE SHIPPED WITHOUT OIL. ADD OIL TO POWER UNIT TANK BEFORE USE.

## MOTOR WILL NOT RUN

### POSSIBLE CAUSE

1. Fuse blown, (1,2,3,4,5)
2. Motor burned out, (1,2,3,4,6)
3. Voltage to motor incorrect, (1,2,8)

### REMEDY

- | REMEDY  | INSTRUCTION   |
|---|---|
| 1. Check for correct voltage . . . . .            | Compare supply voltage with voltage on motor name tag. Check that the wire is sized correctly. N.E.C. table 310-12 requires AWG 10 for 30 Amps.   |
| 2. Check motor is wired correctly . . . . .       | Compare wiring of motor to electrical diagram on drawing.   |
| 3. Don't use extension cords . . . . .            | According to N.E.C. : " The size of the conductors... should be such that the voltage drop would not exceed 3% to the farthest outlet for power..." Do not run motor at 115 VAC – damage to the motor will occur. |
| 4. Replace with new part . . . . .                | Replace with new part.  |
| 5. Reset circuit breaker/fuse . . . . .           | Reset circuit breaker/fuse.   |
| 6. Return unit for repair . . . . .               | Return unit for repair.   |
| 7. See Installation Manual . . . . .              | See Installation Manual.  |
| 8. Check wall outlet voltage and wiring . . . . . | Make sure unit and wall outlet is wired properly. Motor must run at 208/230 VAC 3 phase.  |

## LIFT LOWERS SLOWLY OR NOT AT ALL

### POSSIBLE CAUSE

1. Cylinders binding, (1)
2. Release valve clogged, (5,4,2,3)

### REMEDY

- | REMEDY                               | INSTRUCTION  |
|--------------------------------------|--|
| 1. See Installation Manual . . . . . | Consult Lift Manufacturer.   |
| 2. Replace with new part . . . . .   | Replace with new part.   |
| 3. Return for repair . . . . .       | Return for repair.   |
| 4. Check oil. . . . .                | Use clean 10-WT hydraulic oil or Dexron-III automatic transmission fluid only. If fluid/oil is contaminated, replace with clean fluid/oil and clean entire system. |
| 5. Clean release valve . . . . .     | Wash release valve in solvent and blow out with air.   |

## **IMPORTANT**

If vehicle becomes stranded in the air, follow all operation instructions as shown on pages 25, & 33-35. If after observing that all mechanical locks are released and the lift still fails move following all standard operating procedures, immediately stop using the lift and contact factory or factory approved service center for further instructions.

# WILL NOT RAISE LOADED LIFT

## POSSIBLE CAUSE

1. Air in oil, (1,2,3,4)
2. Cylinder binding, (5)
3. Cylinder leaks internally, (5)
4. Lift overloaded, (5,6)
5. Lowering valve leaks, (1,5,7,8)
6. Motor runs backwards, (8,9,11)
7. Pump damaged, (5,8)
8. Pump won't prime, (1,2,3,4,5,8,10)
9. Relief valve leaks, (5,7,8)
10. Voltage to motor incorrect, (5,9,11)

## REMEDY

1. Check oil level . . . . . The oil level should be up to the fill screw in the reservoir with the lift all the way down.
2. Check/Tighten inlet tubes . . . . . Replace inlet hose assembly.
3. Oil seal damaged or cocked . . . . . Replace oil seal and install.
4. Bleed cylinders . . . . . See Installation Manual.
5. See Installation Manual . . . . . Consult Lift Manufacturer.
6. Check vehicle weight . . . . . Compare weight of vehicle to weight limit of the lift.
7. Replace with new part . . . . . Replace with new part.
8. Return unit for repair . . . . . Return unit for repair.
9. Check motor is wired correctly . . . . . Compare wiring of motor to electrical diagram on power unit drawing.
10. Inlet screen clogged . . . . . Clean inlet screen or replace.
11. Check wall outlet voltage and wiring . . . . . Make sure unit and wall outlet is wired properly.

## INSTRUCTION

**OUR LIFTS ARE SHIPPED WITHOUT OIL. ADD OIL TO POWER UNIT TANK BEFORE USE.**

# LIFT WILL NOT STAY UP

## POSSIBLE CAUSE

1. Air in oil, (1,2,3)
2. Check valve leaks, (5)
3. Cylinders leak internally, (6)
4. Lowering valve leaks, (1,4,5,6)
5. Leaking fittings, (7)

## REMEDY

- | REMEDY  | INSTRUCTION   |
|---|---|
| 1. Check oil level . . . . .                          | The oil level should be up to the fill screw in the reservoir with the lift all the way down. |
| 2. Oil seal damaged and cocked . . . . .              | Replace oil seal around pump shaft.   |
| 3. Bleed cylinder . . . . .                           | Refer to Installation Manual.   |
| 4. Replace with new valve . . . . .                   | Replace with new valve.   |
| 5. Return unit for repair . . . . .                   | Return unit for repair.   |
| 6. See Installation Manual . . . . .                  | Consult Lift Manufacturer.  |
| 7. Check complete hydraulic system for leaks. . . . . | Tighten all hydraulics fittings and inspects all hoses.                                       |

OUR LIFTS ARE SHIPPED WITHOUT OIL. ADD OIL TO POWER UNIT TANK BEFORE USE.

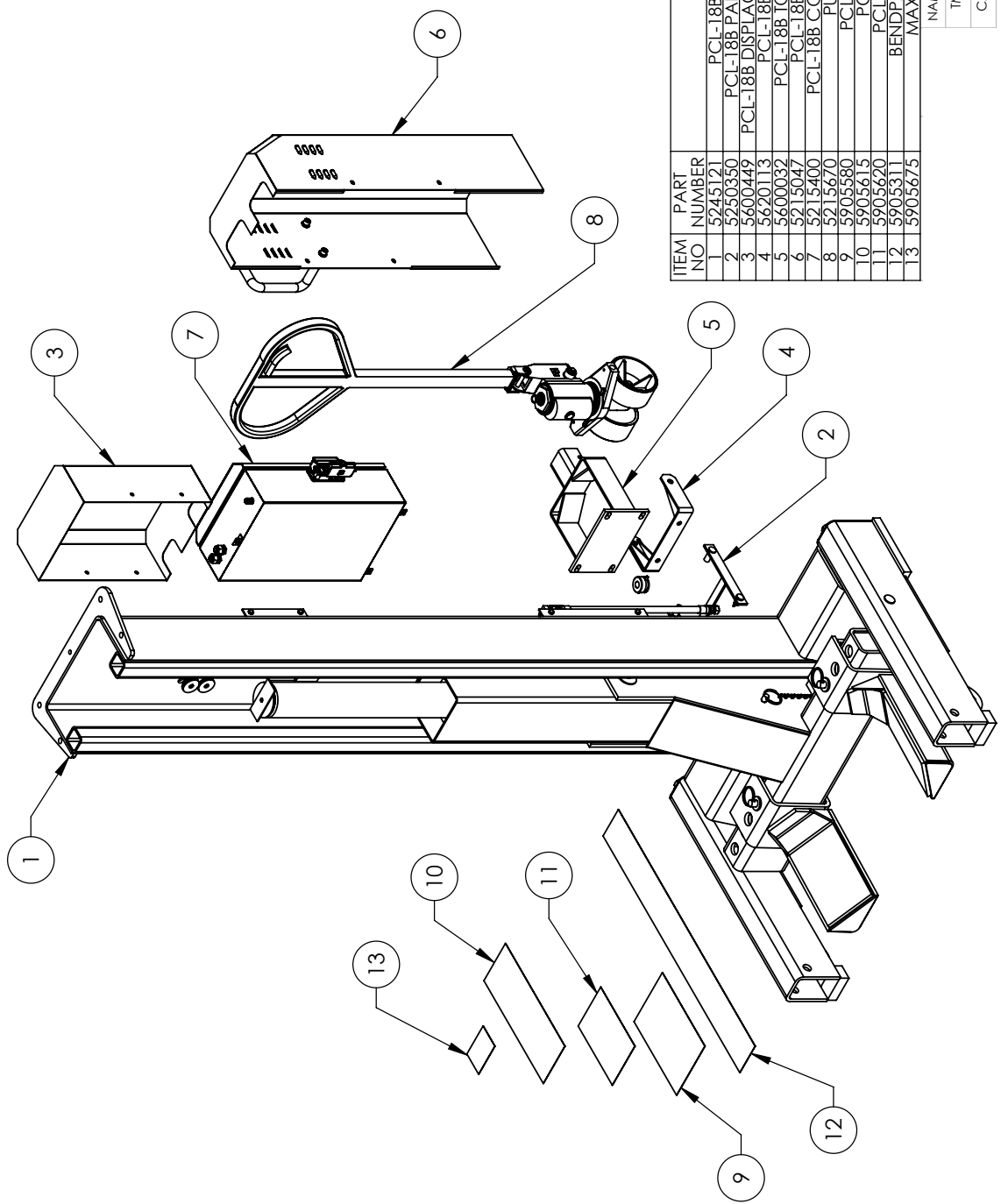

ITEM NO	PART NUMBER	DESCRIPTION	QTY	REV
1	5245121	PCL-18B COLUMN SUPERSTRUCTURE	1	R
2	5250350	PCL-18B PARTS BOX SECONDARY COLUMN	1	C
3	5600449	PCL-18B DISPLACEMENT SENSOR COVER WELDMENT	1	D
4	5620113	PCL-18B TOW ANCHOR WELDMENT	1	D
5	5600032	PCL-18B MOTOR COVER WELDMENT	1	F
6	5215047	PCL-18B MOTOR COVER ASSEMBLY	1	F
7	5215400	PCL-18B CONTROL BOX ASSEMBLY, POST C	1	G
8	5215670	PULL HANDLE ASSEMBLY	1	---
9	5905580	PCL-18 ALL SAFETY LABEL KIT	1	---
10	5905615	PCL-18 WARNING LABEL	1	---
11	5905620	PCL-18 INSTRUCTIONS LABEL	1	---
12	5905311	BENDPAK LABEL - 4 x 38" WHITE INK	1	---
13	5905675	MAX CAP NRTL DANGER 18K	1	---

NAME	DATE
TM	09/30/2011
CA	11/20/2015



TITLE: PCL-18B PRODUCTION COLUMN, POST C  
 SIZE DWG. NO. A 5260331  
 REV L

**BendPak** 1645 LEMONWOOD DR.  
SANTA PAULA, CA 93060

TITLE: PCL-18B PRODUCTION  
COLUMN, POST C  
SIZE DWG. NO. 5260331 REV L  
SCALE: 1:25 SHEET 2 OF 2

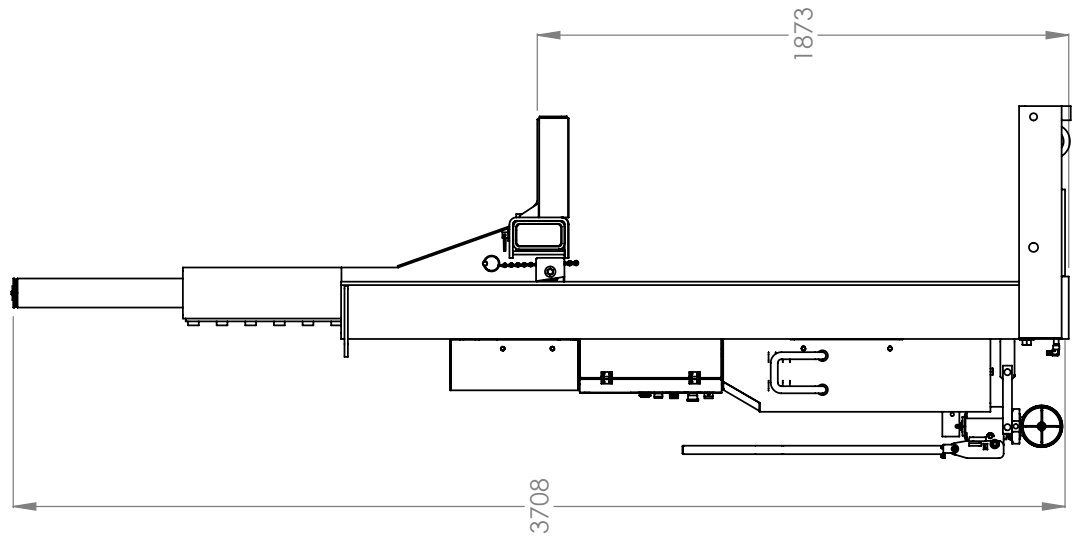
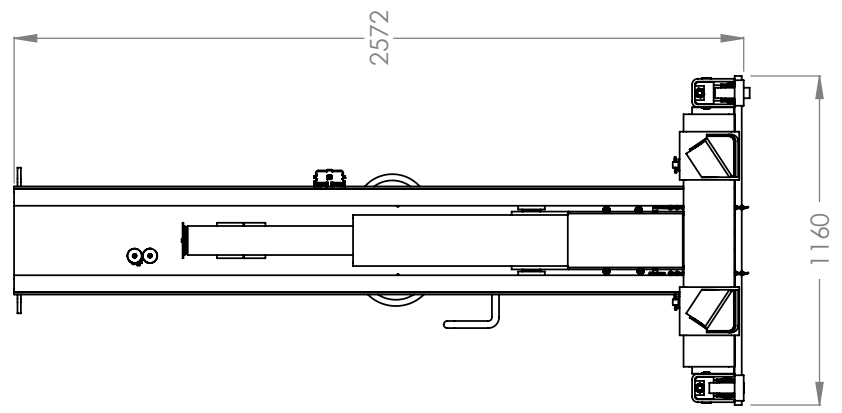
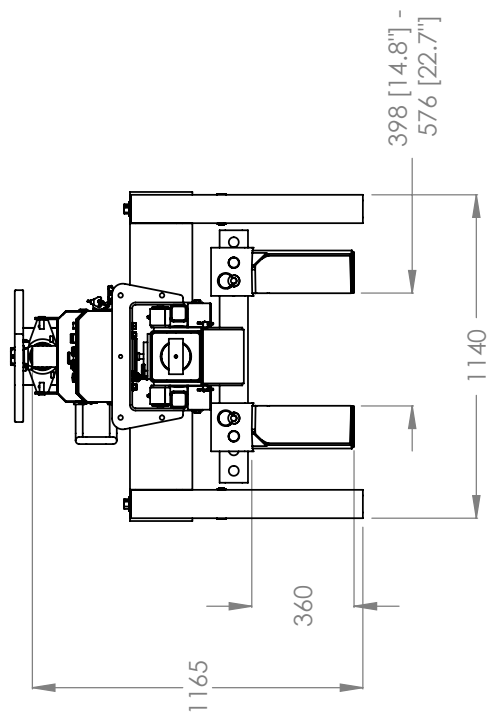

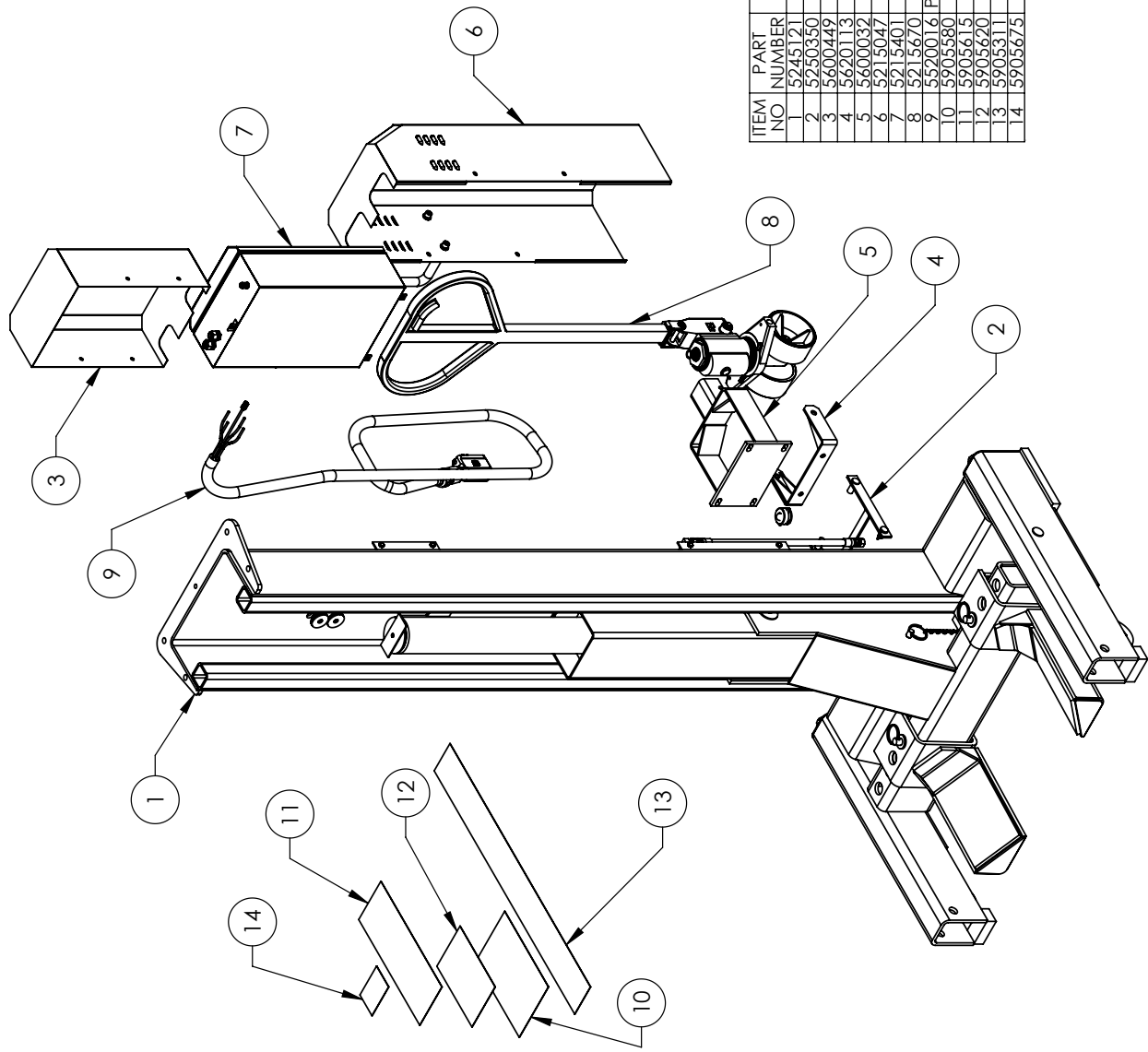

ITEM NO	PART NUMBER	DESCRIPTION	QTY	REV
1	5245121	PCL-18B COLUMN SUPERSTRUCTURE	1	R
2	5250350	PCL-18B PARTS BOX SECONDARY COLUMN	1	G
3	5600449	PCL-18B DISPLACEMENT SENSOR COVER WELDMENT	1	D
4	5620113	PCL-18B TOW ANCHOR WELDMENT	1	D
5	5600032	PCL-18B TOW CART BRACKET WELDMENT	1	F
6	5215047	PCL-18B MOTOR COVER ASSEMBLY	1	F
7	5215401	PCL-18B CONTROL BOX ASSEMBLY, POST D	1	G
8	5215670	PULL HANDLE ASSEMBLY	1	--
9	5520016	PCL-18B 10/4 SOOW/CAT5E COLD CUSTOM CABLE ASSY.	1	A
10	5905580	PCL-18 ALL SAFETY LABEL KIT	1	--
11	5905615	PCL-18 WARNING LABEL	1	--
12	5905620	PCL-18 INSTRUCTIONS LABEL	1	--
13	5905311	BENDPAK LABEL: 4 x 38" WHITE INK	1	--
14	5905675	MAX CAP NRTL DANGER 18K	1	--

DATE  
 09/30/2011  
 11/20/2015



TITLE: PCL-18B PRODUCTION COLUMN, POST D

SIZE DWG. NO. A 5260333  
 REV M

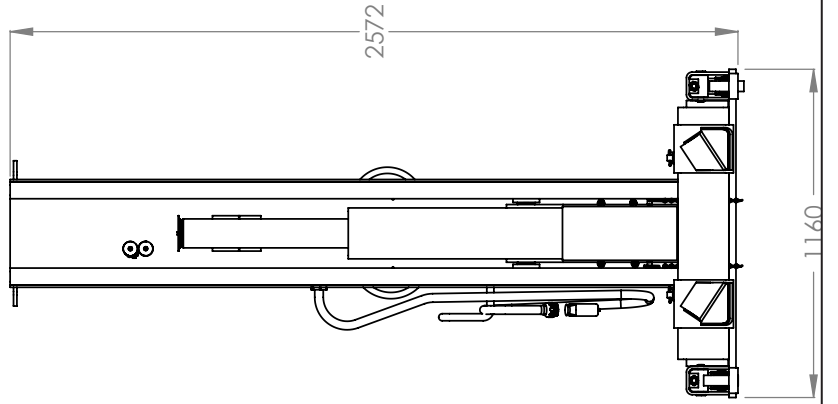
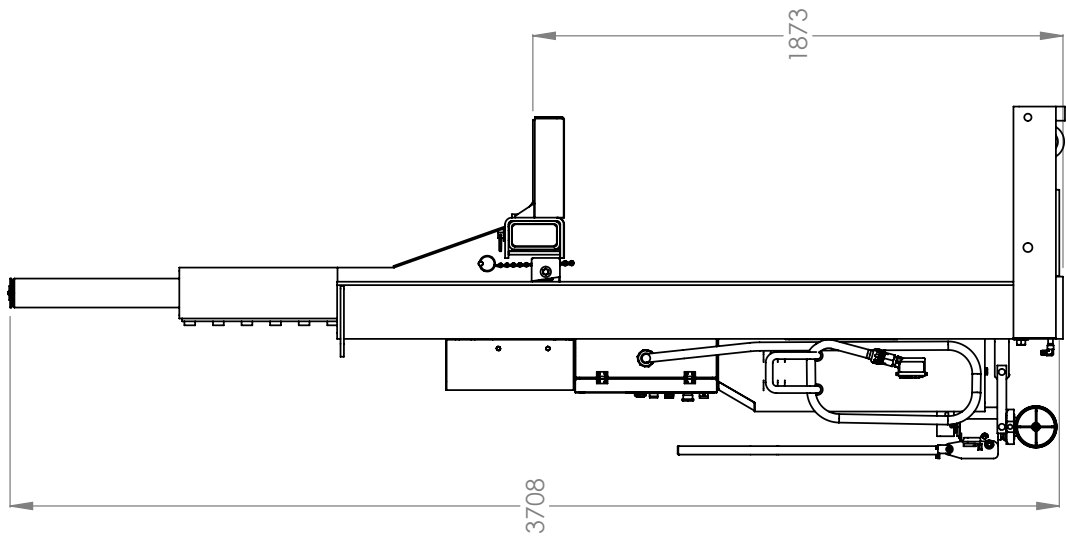
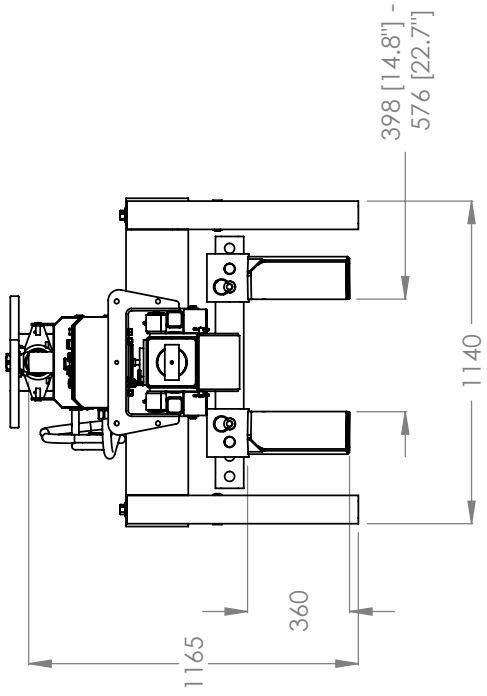

**BendPak** 1645 LEMONWOOD DR. SANTA PAULA, CA 95060

TITLE: PCL-18B PRODUCTION COLUMN, POST D

SIZE DWG. NO. **A** 5260333 REV **M**

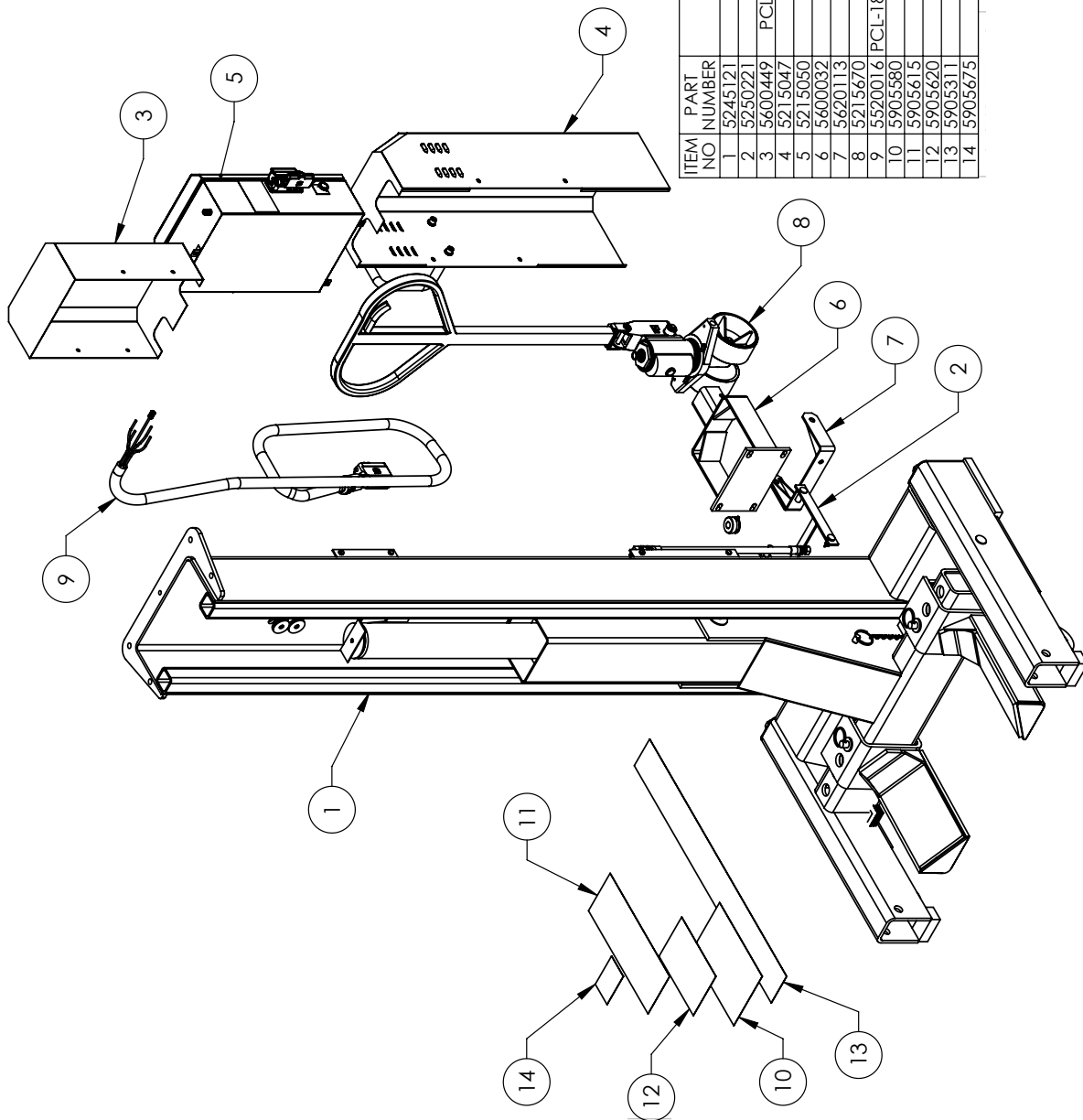

ITEM NO	PART NUMBER	DESCRIPTION	QTY	REV
1	5245121	PCL-18B COLUMN SUPERSTRUCTURE	1	R
2	5250221	PCL-18B PARTS BOX, PRIMARY COLUMN	1	J
3	5600449	PCL-18B DISPLACEMENT SENSOR COVER WELDMENT	1	D
4	5215047	PCL-18B MOTOR COVER ASSEMBLY	1	F
5	5215050	PCL-18B CONTROL BOX ASSEMBLY, POST A	1	J
6	5600032	PCL-18B TOW CART BRACKET WELDMENT	1	F
7	5620113	PCL-18B TOW ANCHOR WELDMENT	1	D
8	5215670	PULL HANDLE ASSEMBLY	1	---
9	5590016	PCL-18B 10/4 SOOW/CAT5E COILD CUSTOM CABLE ASSY.	1	---
10	5905580	PCL-18 ALL SAFETY LABEL KIT	1	---
11	5905615	PCL-18 WARNING LABEL	1	---
12	5905620	PCL-18 INSTRUCTIONS LABEL	1	---
13	5905311	BENDPAK LABEL, 4 X 38" WHITE INK	1	---
14	5905675	MAX CAP NR1L DANGER 18K	1	---

DATE  
 07/14/2009  
 11/20/2015



TITLE: PCL-18B PRODUCTION COLUMN, POST A

SIZE DWG. NO. A 5260130  
 REV U

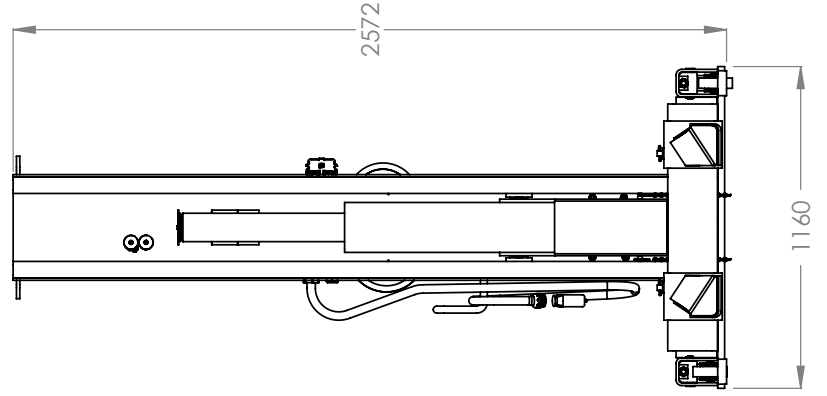
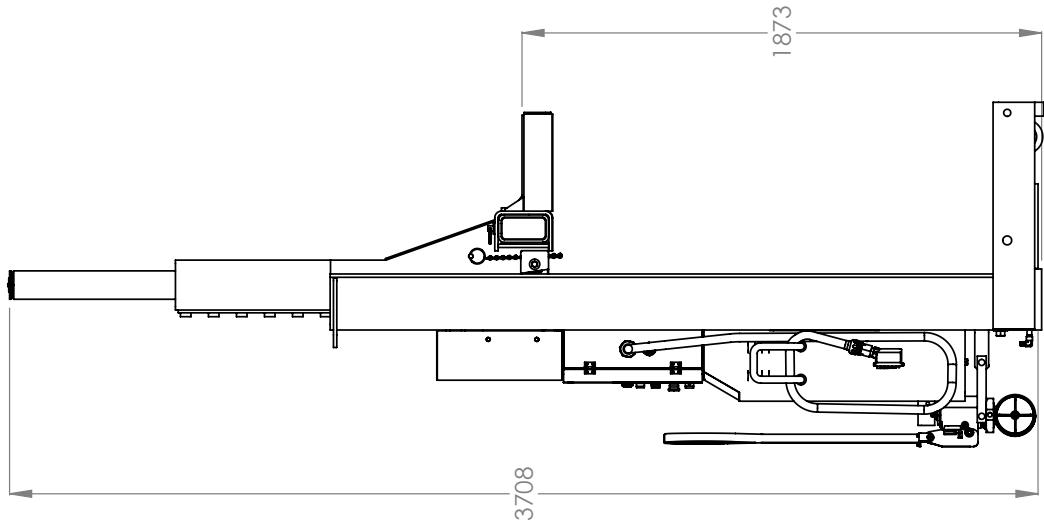
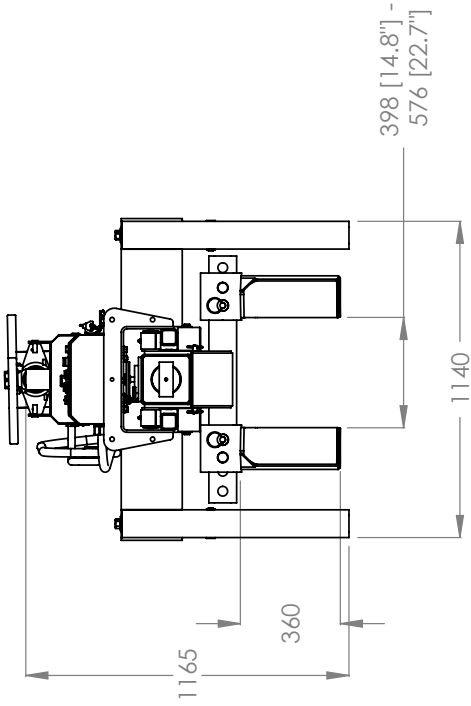

**BendPak** 1645 LEMONWOOD DR.  
SANTA PAULA, CA 93060

TITLE: PCL-18B PRODUCTION  
COLUMN, POST A

SIZE DWG. NO. REV  
**A** 5260130 U

SCALE: 1:25 SHEET 2 OF 2

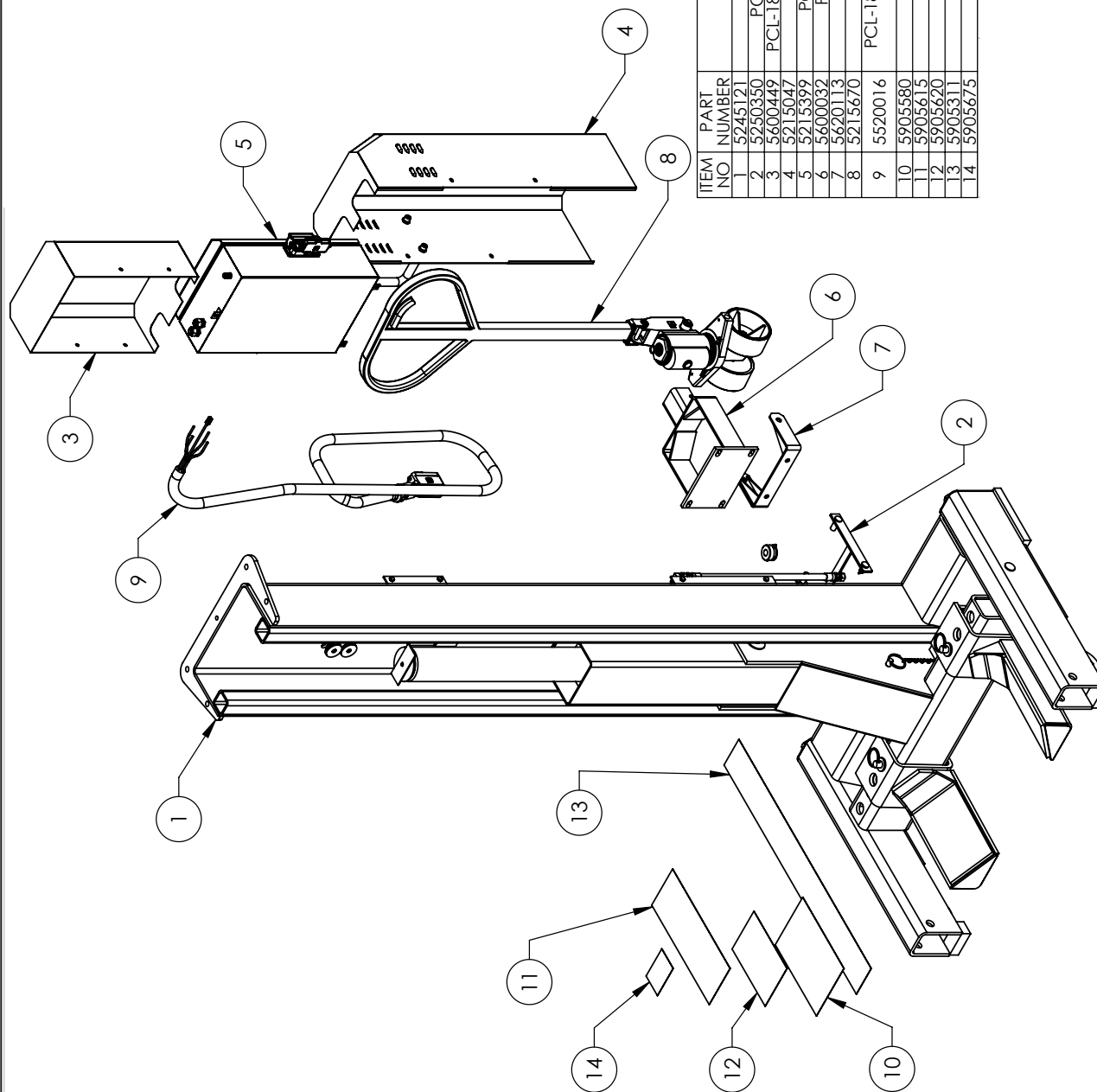

ITEM NO	PART NUMBER	DESCRIPTION	QTY	REV
1	5245121	PCL-188 COLUMN SUPERSTRUCTURE	1	R
2	5250350	PCL-188 PARTS BOX, SECONDARY COLUMN	1	G
3	5600449	PCL-188 DISPLACEMENT SENSOR COVER WELDMENT	1	D
4	5215047	PCL-188 MOTOR COVER ASSEMBLY	1	F
5	5215399	PCL-188 CONTROL BOX ASSEMBLY, POST B	1	G
6	5600032	PCL-188 TOW CART BRACKET WELDMENT	1	F
7	5620113	PCL-188 TOW ANCHOR WELDMENT	1	D
8	5215670	PULL HANDLE ASSEMBLY	1	--
9	5520016	PCL-188 10/4 SOOW/CA15F COILD CUSTOM CABLE ASSY.	1	A
10	5905580	PCL-18 ALL SAFETY LABEL KIT	1	--
11	5905615	PCL-18 WARNING LABEL	1	--
12	5905620	PCL-18 INSTRUCTIONS LABEL	1	--
13	5905311	BENDPAK LABEL - 4 x 38" WHITE INK	1	--
14	5905675	MAX CAP NR1L DANGER 18K	1	--

DATE  
 09/30/2011  
 11/20/2015

1645 LEMONWOOD DR.  
 BENDPAK  
 SANTA PAULA, CA 93060

TITLE: PCL-188 PRODUCTION  
 COLUMN, POST B

REV  
 L

SIZE DWG. NO.  
 A 5260330

SCALE: 1:18

SHEET 1 OF 2

**BendPak** 1645 LEMONWOOD DR.  
SANTA PAULA, CA 93060

TITLE: PCL-18B PRODUCTION  
COLUMN, POST B

SIZE DWG. NO. REV  
**A** 5260330 L

SCALE: 1:25 SHEET 2 OF 2

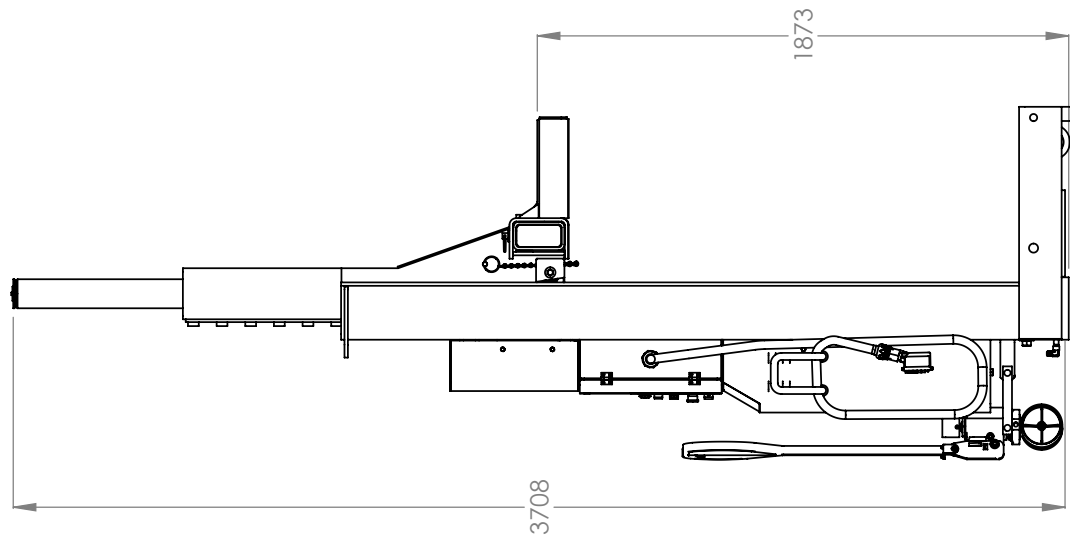
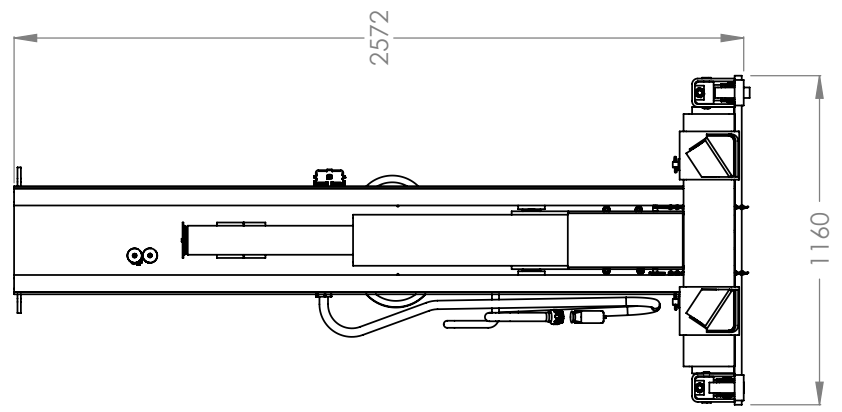
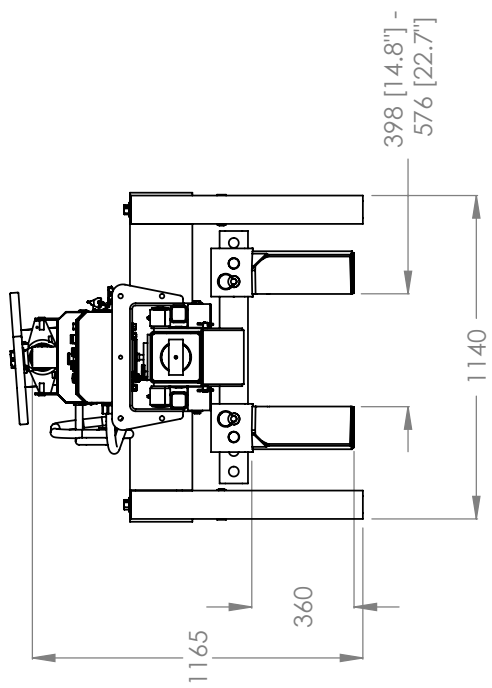

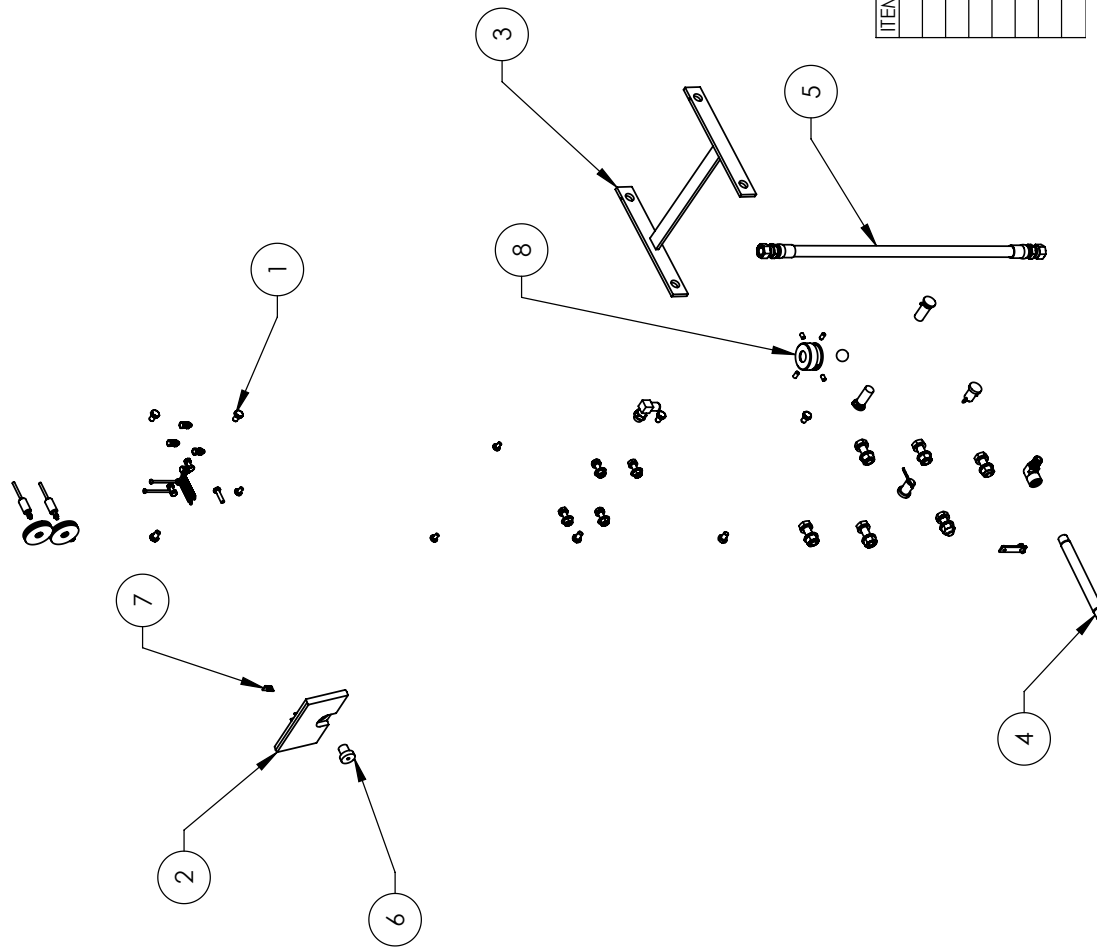

ITEM NO	PART NUMBER	DESCRIPTION	QTY	REV
1	5174499	PCL-18B PARTS BAG	1	G
2	5600704	PCL-18B SAFETY BLOCK WELDMENT	1	C
3	5600278	PCL-18B TOW CART TIE PLATE WELDMENT	1	D
4	5756113	PCL-18B HYDRAULIC TUBE	1	C
5	5570872	PCL-18B HYD. HOSE ASSY Ø10 x 850mm DS	1	C
6	5746615	PCL-18B SAFETY PIVOT PIN	1	D
7	5721099	PCL-18B SOLENOID TRIP BRACKET	1	D
8	5746257	PCL-18B WHEELED JACK RETAINER RING	1	C

DATE  
 11/02/2011  
 11/20/2015



TITLE: PCL-18B PARTS BOX,  
 SECONDARY COLUMN  
 SIZE DWG. NO. **A** 5250350  
 REV **G**  
 SCALE: 1:12  
 SHEET 1 OF 1

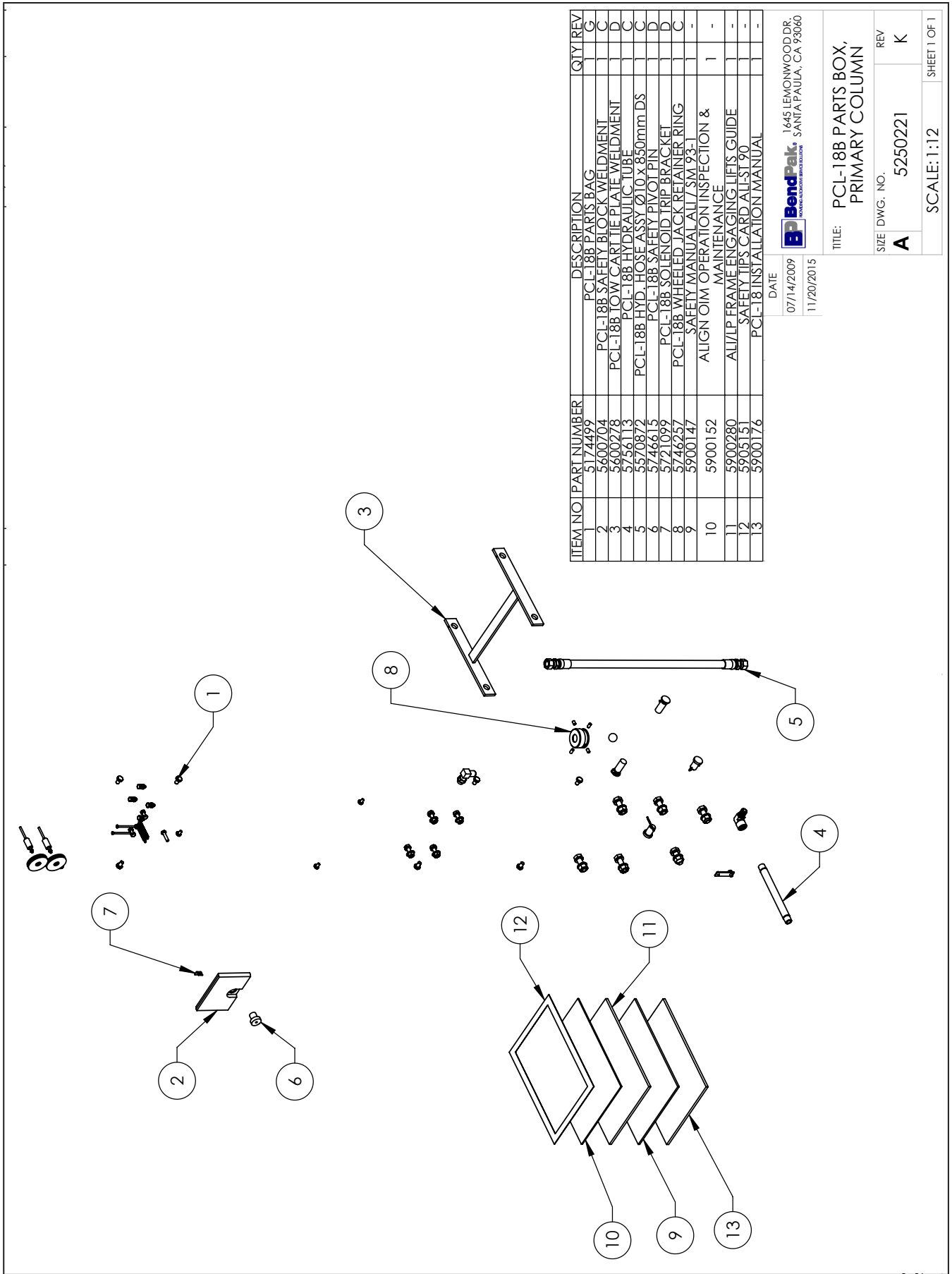

DATE  
07/14/2009  
11/20/2015

**BendPak**  
1645 LEMONWOOD DR.  
SANTA PAULA, CA 93060

TITLE: PCL-18B PARTS BOX,  
PRIMARY COLUMN

SIZE DWG. NO. **A** 5250221 REV **K**

SCALE: 1:12 SHEET 1 OF 1

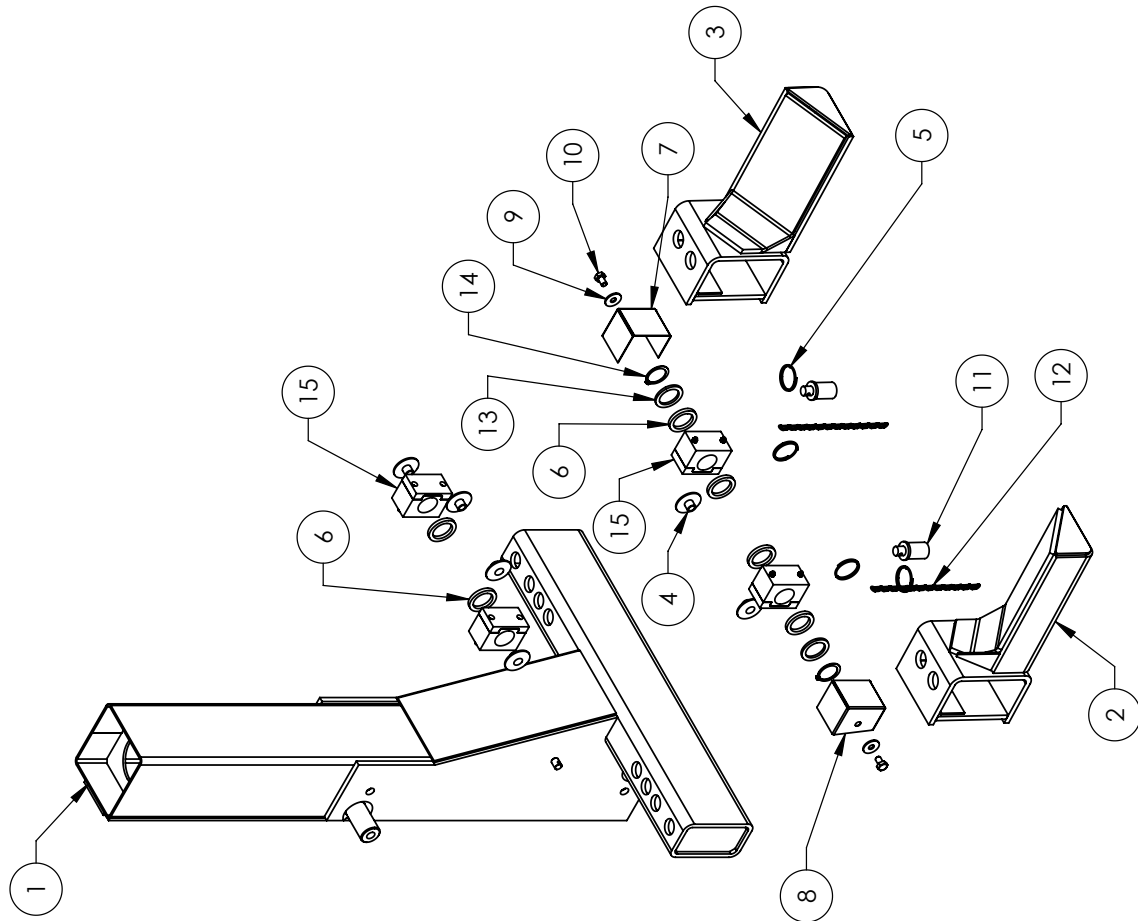

ITEM NO	PART NUMBER	DESCRIPTION	QTY	REV
1	5600448	PCL-188 CARRIAGE WELDMENT	1	H
2	5600884	PCL-188 RIGHT FORK ARM WELDMENT	1	B
3	5600885	PCL-188 LEFT FORK ARM WELDMENT	1	B
4	5716156	PCL-188 CARRIAGE SLIDE	6	C
5	5580219	KEYRING, 56mm x 3mm	4	---
6	5716159	PCL-188 CARRIAGE SLIDER SPACER	6	F
7	5701424	PCL-188 CARRIAGE ROLLER COVER, R.H.	1	B
8	5701459	PCL-188 CARRIAGE ROLLER COVER, L.H.	1	E
9	5545027	WASHER M12 x Ø37 x 3mm	2	---
10	5530164	HBB M12 x 1.75 x 20	2	---
11	5746619	PCL-188 FORK PIN	2	C
12	5510105	PCL-188 LIFT HEAD PIN CHAIN	2	---
13	5746973	PCL-188 ROLLER BEARING BACKUP PLATE	2	D
14	5540124	RETAINING RING, TRUARC 5100-177	2	---
15	5215421	PCL-188 CARRIAGE SLIDER ASSEMBLY, BRASS	4	C

DATE

11/13/2007  
09/23/2015

**BP BendPak** 1645 LEMONWOOD DR.  
SANTA PAULA, CA 93060

TITLE:

PCL-188 CARRIAGE  
ASSEMBLY

SIZE DWG. NO.

**A**

5215034

REV

**K**

## Crossbeam Accessory

The PCL-18B has a Crossbeam available as an accessory.

The Crossbeam goes between two PCL-18Bs, sitting in their troughs.

The Crossbeam comes with adapters: two cradle adapters (which fit onto the Crossbeam), two short cradle lift adapters, and two tall cradle lift adapters.

The Crossbeam also comes with a caster kit, which allows the Crossbeam to be easily moved around.

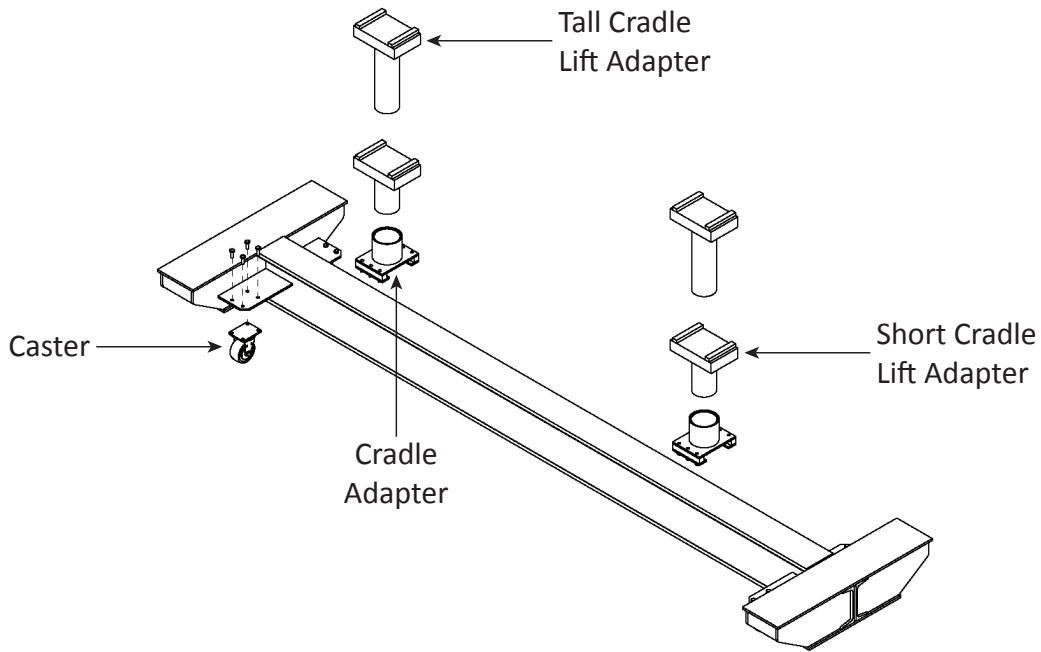

The Crossbeam can support a full 36,000 lbs / 8165 kg for much of its length of 122 inches / 3098.8 mm. However, as the adapters are moved towards the middle of the Crossbeam, the load that can be supported is reduced to a maximum total of 12,950 lbs.

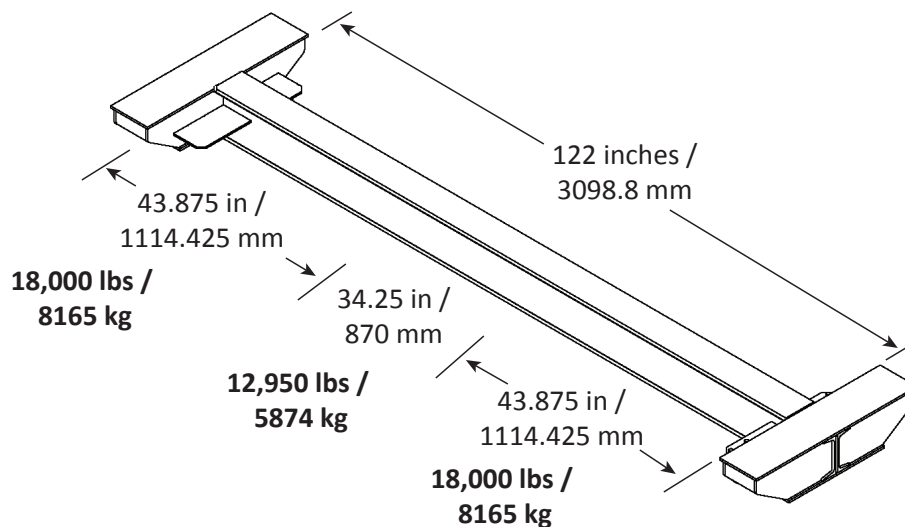



1645 Lemonwood Dr. ● Santa Paula, CA. 93060, USA  
Toll Free: 1(800) 253-2363

**FOR TECHNICAL SUPPORT**  
1-(800) 253-2363 Ext. 196  
**TO ORDER PARTS**  
1-(800) 253-2363 Ext. 191