

ELGi TM	USER'S AND MAINTENANCE MANUAL	Date:	09/04/2024
		Code	MAN D90KA ENG
Motor compressor: D90KA		Revision	06



USER'S AND MAINTENANCE MANUAL

MOTOR COMPRESSOR

D 90KA



	USER'S AND MAINTENANCE MANUAL	Date:	09/04/2024
		Code	MAN D90KA ENG
Motor compressor: D90KA		Revision	06

Dear customer,

Thanks for having purchased this ELGI motor compressor, which is designed and manufactured in compliance with high standards, in order to ensure high quality performance, as well as easy use and installation.

For any information, you can contact our customer service at the following address:

ELGI PORTABLE COMPRESSORS

4610 Entrance Drive St A
Charlotte, NC 28273
704-523-4123

Portableservice@elgi.com

Portablesales@elgi.com



	USER'S AND MAINTENANCE MANUAL	Date:	09/04/2024
		Code	MAN D90KA ENG
Motor compressor: D90KA		Revision	06

FOREWORD

These service instructions have been drafted to facilitate the knowledge of the machinery purchased and its modes of use.

In drafting them, we have intentionally omitted the technical in-depth description of some operations linked to the motor and the axle, since such information is contained in the user's and maintenance of the respective manufacturers.

The service instructions contain indications of utter importance concerning the safe appropriate and cost-effective operation of the machine.

The compliance with said operations helps prevent potentially hazardous situations, additional costs and loss of time, increasing at the same time its life-span.

The service instructions and safety measures reported in this manual must be complied with by the user of the machinery.

Besides the service instructions and the accident prevention prescriptions which apply in the countries and places of installation, all the more general rules of safety at the workplace must be complied with.

It is therefore recommended to carefully read the instructions reported in this manual.

This manual cannot be disclosed, duplicated or copied without the previous authorization by the Manufacturer. Any lack of compliance with the above shall be pursued under the Law, in particular if the illicit action involves advantage for competing companies.



	USER'S AND MAINTENANCE MANUAL	Date:	09/04/2024
		Code	MAN D90KA ENG
Motor compressor: D90KA		Revision	06

TABLE OF CONTENTS

1	General	7
1.1	Definitions.....	7
1.1.1	Qualified personnel	7
1.1.2	Hazard.....	7
1.1.3	Hazardous area.....	7
1.1.4	Exposed person	7
1.1.5	Operator	7
1.1.6	Risk	7
1.1.7	Guard	7
1.1.8	Protection Equipment.....	7
1.1.9	Expected use	7
1.1.10	Reasonably expectable incorrect use	7
1.1.11	Component.....	7
1.1.12	Control Device.....	7
1.1.13	Safety interlock.....	8
1.1.14	Manufacturer	8
1.2	Machinery Identification	8
1.3	Harmonized technical standards.....	9
1.4	General description of the machinery	10
2	Technical characteristics of the machinery	11
2.1	General technical characteristics	11
2.2	Technical characteristics of the compressor.....	11
2.3	Technical characteristics of the engine	12
2.4	Technical characteristics of the electric battery	12
2.5	Service temperatures	12
3	Symbols and warnings	13
3.1	Hazards.....	13
3.2	Forbiddances.....	14
3.3	Obligations and notices.....	15
3.4	General notices	15
4	Use of the machinery	17
4.1	Use allowed.....	17
4.2	Use not allowed.....	17
4.3	Residual risk.....	18
5	Levels and qualifications of the personnel	19
6	Safety provisions	19
6.1	Safety provisions concerning transport.....	19
6.2	Safety provisions concerning lifting.....	19
6.3	Safety provisions relevant to towing (for road-certified compressors only)	21
6.4	Prescriptions for the installation and parking of the motor compressor	22
6.5	Safety provisions concerning maintenance	23

	USER'S AND MAINTENANCE MANUAL	Date:	09/04/2024
		Code	MAN D90KA ENG
Motor compressor: D90KA		Revision	06

6.6	Safety provisions concerning toolbox.....	24
7	Machinery components.....	25
7.1	Chassis and axle	25
7.2	Body	25
7.3	Engine	25
7.4	Compression unit	25
7.5	Separator tank.....	26
7.6	Belts and pulley.....	26
7.7	Control panel.....	26
8	Electrical equipment of the machinery.....	27
8.1	Operator's panel tools	27
8.2	Operator's panel pilot lamps.....	28
8.3	Fuses.....	31
8.4	Lights (for EU road-certified version)	32
9	Hydraulic and pneumatic systems	34
9.1	Hydraulic lubrication system	34
9.2	Pneumatic system.....	35
9.2.1	Automatic adjustment of the engine rpm	36
10	Provisions for the appropriate utilization of the motor compressor	37
10.1	Before starting-up.....	37
10.2	Start-up.....	38
10.3	During the work cycle	40
10.4	Stop	40
10.5	After stopping the machine	40
11	Monitoring and testing of the machine	41
11.1	Monitoring and testing of engine speed	41
11.1.1	Control system of maximum engine speed.....	41
11.1.2	Control system of minimum engine speed.....	41
11.2	Monitoring and control of the air pressure of the compressor	43
11.3	Monitoring and control of air pressure minimum compressor.....	44
12	Safety device (only eu vers.)	45
12.1	Emergency stop buttons	45
12.1.1	Operation of the emergency button	45
12.2	Verification of the safety valve	46
13	Maintenance	47
13.1	Routine maintenance	47
13.2	Maintenance program	48
13.3	Values of tightening screws and bolts.....	50
13.4	Maintenance.....	51
13.4.1	Checking the filter air intake.....	51



USER'S AND MAINTENANCE MANUAL

Date:	09/04/2024
Code	MAN D90KA ENG
Revision	06

Motor compressor: D90KA

13.4.2	Control the electrical battery	52
13.4.3	Fuso replacement	53
13.4.4	Replacement lamps light (for version approved)	53
13.4.5	Tyre pressure monitoring	54
13.4.6	Clean the radiator cooler	55
13.4.7	Percentage dosage of cooling liquid	55
13.4.8	Checking and cleaning nozzle oil recovery	56
13.4.9	Drainage of the fuel tank	56
13.4.10	Replacing diesel pre-filter	57
13.4.11	Check break device	57
13.4.12	Control of locking wheel bolts	58
13.4.13	Oil filter replacement compressor	58
13.4.14	Replacement of compressor oil	59
13.4.15	Checking the oil mist separator	59
13.4.16	Replacement of the oil separator filter	60
13.4.17	Engine control and maintenance	60
13.4.18	Control, tension and replacement of transmission belts	61
14	Spare parts	62
15	Faults and troubleshooting	63
16	Disposal, elimination, disposal of the machine	65
16.1	Instructions for dismantling	65
17	Eliminating the machine	65
18	Waste management	66
18.1	Special waste	66
18.2	Toxic and hazardous waste	66
18.3	Temporary storage	66
18.4	Features of the containers	66
18.5	Registration requirements	66



	USER'S AND MAINTENANCE MANUAL	Date:	09/04/2024
		Code	MAN D90KA ENG
Motor compressor: D90KA		Revision	06

1 GENERAL

1.1 Definitions

The most significant definitions contained in this manual are reported hereinafter

1.1.1 QUALIFIED PERSONNEL

"Qualified personnel" are those personnel who are familiar with the rules for installation, assembly, repair and servicing of the machinery and who are provided with the specified technical qualification, such as e.g.:

Technical training authorizing to operate in compliance with the safety standards as related to the hazards the presence of electric current, pressure circuits, etc. may involve.

Technical background or - in any case - specific training relevant to the user's and maintenance procedures of the machinery in safety conditions.

Training in the basic first-aid activities.

1.1.2 HAZARD

A potential source of injury or damage to health

1.1.3 HAZARDOUS AREA

Any area within and/or in proximity of machinery where the presence of a person constitutes a risk for the health and safety of said person.

1.1.4 EXPOSED PERSON

Any person being fully or partially in a hazardous area

1.1.5 OPERATOR

The person/people charged to install, operate, adjust, clean, repair or move a Machinery or perform its maintenance.

1.1.6 RISK

Combination of the likelihood and severity of an injury or damage to health which may arise in a hazardous situation.

1.1.7 GUARD

Part of the machinery utilized to ensure protection by means of a material barrier.

1.1.8 PROTECTION EQUIPMENT

Device (different from a guard) which reduces the risk, by itself or associated to a guard.

1.1.9 EXPECTED USE

The use of the machinery in compliance with the user's information.

1.1.10 REASONABLY EXPECTABLE INCORRECT USE

The use of the machinery in a different way than the one indicated in the user's instructions, but which may derive from the easily expectable human behaviour.

1.1.11 COMPONENT

A constituent part of the electrical/pneumatic equipment, usually specified by its function, but used in various applications.

1.1.12 CONTROL DEVICE

A device introduced in a control circuit and used to control the operation of the system (e.g. position sensors,



	USER'S AND MAINTENANCE MANUAL	Date:	09/04/2024
		Code	MAN D90KA ENG
Motor compressor: D90KA		Revision	06

manual control switches, relays, electro-magnetic control valves).

1.1.13 SAFETY INTERLOCK

Mechanical, electrical or other device whose purpose is to prevent the parts of the machinery from operating in specified conditions (generally, until the guard is closed)

1.1.14 MANUFACTURER

Physical or legal person who designed and/or develops machinery or partly-completed machinery which is subject of this directive and who is liable for the compliance of the machinery or partly-completed machinery with this directive as related to its marketing with his/her name or brand, or for personal use. In absence of a Manufacturer as defined above, the Manufacturer shall be considered the physical or juridical person who markets or puts into service machinery or partly-completed machinery.

1.2 Machinery Identification

The identification nameplate is attached on the motor compressor chassis.

Such nameplate reports the Manufacturer's data, the denomination of the machinery, the code and year of manufacturing.

For any requests for spare parts or actions by our technicians, please refer to the data reported in the nameplate; in particular the code number of the machinery must always be mentioned.

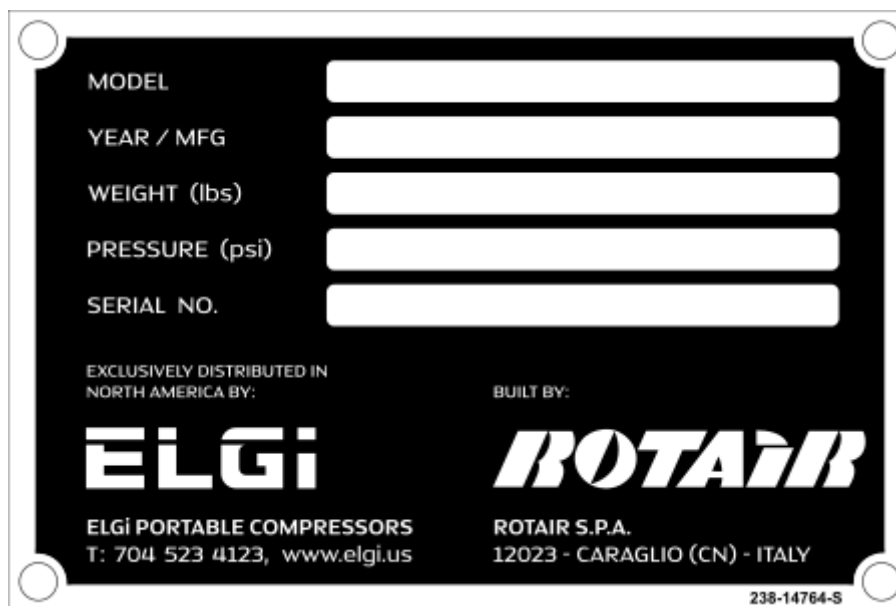



Figure 1.2-1 Nameplate of motor compressor D90KA



	USER'S AND MAINTENANCE MANUAL	Date:	09/04/2024
		Code	MAN D90KA ENG
Motor compressor: D90KA		Revision	06

1.3 Harmonized technical standards

The machinery has been designed and developed in compliance with the provisions contained in the technical standards reported herein under:

UNI EN ISO 12100	Safety of machinery -General design principles - Risk assessment and risk reduction.
UNI EN ISO 13857	Safety of machinery– Safety distances to prevent from reaching the hazardous areas with the upper or lower limbs.
UNI EN ISO 13850	Safety of machinery - Emergency stop system, functional aspects
CEI EN 62061	Safety of machinery - Functional safety of the programmable electrical and electronic control systems as related to safety
CEI EN 60204-1	Safety of machinery - Electrical equipment of the machineries. Part I: General rules.
UNI EN 983	Safety of machinery. Safety requirements relevant to systems and related components for hydraulic and pneumatic transmission. Pneumatics.
UNI EN 349	Safety of machinery - Minimum openings to prevent the crushing of parts of the human body.
D. LGS. January 27th 2010 no.17	Implementation of Directive 2006/42/CE relevant to machinery, which modifies directive 95/16/CE relevant to elevators.
UNI EN ISO 14121-1	Safety of machinery - Risk assessment. General principles
UNI EN ISO -TR 14121-2	Safety of machinery - Examples

	Machine directive 2006/42/CE.
<p>Article 7. Presumption of conformity and harmonized standards</p> <p>1. The Member States deem that the machinery provided with the “CE” marking and accompanied by the CE declaration of conformity, whose elements are provided for in Annex II, Part 1, Section A, comply with the provisions of this directive.</p> <p>2. The machinery manufactured in compliance with an authorized standard, whose reference has been published on the Official Journal of the European Union is assumed to be compliant with the essential health and safety requirements covered by such harmonized standard.</p> <p>3. The Commission published the references of the harmonized standards in the Official Journal of the European Union.</p> <p>4. The Member States shall take the appropriate measures to allow the social partners influencing - at national level - the development and control process of the harmonized standards.</p>	

	USER'S AND MAINTENANCE MANUAL	Date:	09/04/2024
		Code	MAN D90KA ENG
Motor compressor: D90KA		Revision	06

1.4 General description of the machinery

The machinery described in this manual is motor compressor D90KA.

The motor compressor is a piece of machinery with the capacity of generating a given quantity of compressed air in l/m by using a diesel engine as primary energy.

The pneumatic energy finds applications in different fields of use, where "pneumatic" operation tools, accessories and equipment are utilized. For instance: demolition hammers, drilling hammers, vibrators, drilling machines, rammers, coating machines, etc.

Each of these tools/-accessories has its own consumption of compressed air, expressed in liters per minute.

The optimum coupling between the compressor and the tool is achieved when the compressed air consumption does not exceed 85% of the air generated by the compressor (furthermore, it must be taken into consideration that the quantity of compressed air required by the tool shall increase in time, proportionally to the wear of the tool itself).

The correct compressor-tool coupling ratio allows the machinery operating in optimum conditions, as appropriate to ensure long life-span at the highest performance.

An oversized tool - besides creating unfavourable conditions for the appropriate operation of the machinery - shall not develop full performance, since it cannot resort to the required quantity of compressed air.

This machinery has been designed to work at ambient temperature ranging from -10°C [14°F] and +40° C [105°F].



	USER'S AND MAINTENANCE MANUAL	Date:	09/04/2024
		Code	MAN D90KA ENG
Motor compressor: D90KA		Revision	06

2 TECHNICAL CHARACTERISTICS OF THE MACHINERY

The general technical characteristics of the machinery are reported hereinafter.

2.1 General technical characteristics

DESCRIPTION	TECHNICAL VALUES AND DATA
Length	9 ft 8 in
Width	4 ft. 6 in
Height (with hood closed)	4 ft
Mass of the braked version	1411 lbs
Compression system	Screw single-stage
Fuel tank capacity	10.50 gal
Tire data	135/80 R13
Pressure value of inflation	36.70 Psi

2.2 Technical characteristics of the compressor

DESCRIPTION	TECHNICAL VALUES AND DATA
Service pressure	87 psi
Minimum pressure	80 psi
Max. pressure	109 psi
Rated payload at service pressure	90 CFM
Cooling typology	Specific oil for screw compressors (*)
Hydraulic system capacity	1.60 gal
Separator tank capacity	2.64 gal

(*) For the recommended oil see Paragraph 13.4.14





USER'S AND MAINTENANCE MANUAL

Date: 09/04/2024

Code MAN D90KA ENG

Motor compressor: D90KA

Revision 06

2.3 Technical characteristics of the engine

DESCRIPTION	TECHNICAL VALUES AND DATA
Engine brand	KUBOTA
Type	D1105-E4B
Number of cylinders	3
Fuel	Diesel
Cooling	By liquid
Power available	18.5 kW (25Hp) at 3000 rpm
Max. rotation speed	3000 r.p.m.
Min. rotation speed	1900 r.p.m.
Emissions	Tier 4 final
Engine oil tank capacity	1.30 gal

2.4 Technical characteristics of the electric battery

DESCRIPTION	TECHNICAL VALUES AND DATA
Rated voltage	12 Vdc
Capacity	70 Ah
Discharge current	400 A

2.5 Service temperatures

DESCRIPTION	TECHNICAL VALUES AND DATA
Minimum ambient temperature limit	-10°C [14 ° F]
Maximum ambient temperature limit	+40° C [105°F]
Humidity limits	≤ 50% (a +40°C-105°F)
Altitude	3.280 feet above sea level



	USER'S AND MAINTENANCE MANUAL	Date:	09/04/2024
		Code	MAN D90KA ENG
Motor compressor: D90KA		Revision	06

3 SYMBOLS AND WARNINGS

The pictograms and main warning for the operators are reported herein under and indicated by the following denominations and symbols:

3.1 Hazards



WARNING

The pictogram calls the attention of specific provisions in order to prevent damage.



WARNING FOR ELECTRICAL HAZARD

The pictogram calls the attention of specific provisions in order to prevent damage.



WARNING FOR CRUSHING HAZARD

The pictogram calls the attention on a likely hazardous situation with risk of crushing the upper limbs.



WARNING HAZARD OF ORGANS IN MOTION

The pictogram calls the attention to the hazard of organs in motion.



WARNING ON RISK OF SCALDING OR HAZARD DUE TO HIGH-TEMPERATURE ELEMENTS

The pictogram calls the attention on the hazard of high-temperature elements and risk of scalding.



**WARNING:
OVERHANG
ING LOADS**

OVERHANGING LOAD WARNING

The pictogram calls the attention to the hazard due to the presence of overhanging loads



WARNING OF THE PRESENCE OF PRESSURE VESSELS

The pictogram calls the attention to the presence of pressure vessels.



	USER'S AND MAINTENANCE MANUAL	Date:	09/04/2024
		Code	MAN D90KA ENG
Motor compressor: D90KA		Revision	06

3.2 Forbiddances



FORBIDDANCE TO REMOVE THE PROTECTION EQUIPMENT AND THE GUARDS

The pictogram calls the attention on the forbiddance to remove protection equipment such as fixed, movable, interlock guards or to tamper with photocells or photocell barriers.



FORBIDDANCE TO PERFORM CLEANING OR MAINTENANCE WHEN THE MACHINERY IS IN MOTION

The pictogram calls the attention on the forbiddance to perform cleaning or maintenance operations with organs in motion.



FORBIDDANCE TO TRANSIT UNDER OVERHANGING LOADS

The pictogram calls the attention on the forbiddance to transit under overhanging loads.



FORBIDDANCE TO START THE MACHINERY WHEN THE HOOD IS OPEN



	USER'S AND MAINTENANCE MANUAL	Date:	09/04/2024
		Code	MAN D90KA ENG
Motor compressor: D90KA		Revision	06

3.3 Obligations and notices



NOTICES

This symbol recommends to consult the manual before undertaking a given action.



OBLIGATIONS TO USE THE PPE (PERSONAL PROTECTION EQUIPMENT)

The pictogram calls the attention on the obligation to use the personal protection equipment.



NOTICES

This symbol highlights that the description involves significant parts, since they may cause severe mechanical and electrical damage and malfunctions if the relevant standards are not complied with. It is recommended to comply with the information contained in this manual and with the law provisions in force as related to health and safety at the workplace.



HIGHLIGHTING OF THE HOOKING POINT TO LIFT THE MACHINERY.



OBLIGATION TO USE THE SUPPORT FOOT, THE PARK BRAKE AND WHEEL LOCKING WEDGES.

3.4 General notices

This manual includes the user's and routine maintenance instructions of the machinery. Whenever it is not specified otherwise, the operational and maintenance actions are to be considered as "specialized", i.e. they can only be performed by a technician appointed to the purpose.

Before undertaking any operation on the machinery, carefully read this manual.

ELGI declines any responsibility for any operation performed in conflict with the contents of this document.

Before utilizing the machinery, carefully read this document and comply with the safety law, regulations and standards in force.

This manual and the annexed documents must be considered as an integral part of the machinery they refer to and must always accompany the machinery, even if the latter is transferred to another user. It is therefore appropriate to preserve them for further reference.

This manual and the annexed documents are specific for the machinery they have been drafted for.



Do NOT utilize this manual and the annexed documents to run operations on similar machinery, of the same brand or typology.



	USER'S AND MAINTENANCE MANUAL	Date:	09/04/2024
		Code	MAN D90KA ENG
Motor compressor: D90KA		Revision	06

ELGI is available to its Customer for any further information. Please report the information (type of machinery, model and code) contained in the machinery identification nameplate. All the specific data not indicated in the text are mentioned in chapter "Technical characteristics of the Machinery" as well as in the technical annexes of this user's and maintenance manual.

This manual thoroughly describes:

- The information relevant to towing, lifting and parking of the machinery;
- The general rules and recommendations useful for routine and extraordinary maintenance;
- The modalities to identify and order the spare parts.

Remark: the instructions for the appropriate use of the engine are described in the manual drafted by the engine manufacturer.

This manual must be preserved with care, in its folder, far from sources of humidity, heat and sun rays, so that it can be consulted at any time by both the personnel appointed to the use and by those who need to perform routine and extraordinary maintenance.

This machinery has been exclusively designed and manufactured to deliver compressed air in the conditions stated by the Manufacturer. Every other utilization not mentioned in the "expected uses" shall relieve the manufacturer from any liabilities, which will be at full charge of the user.

"Approved purpose" assumes compliance with the provisions reported hereinafter and related to the appropriate use and maintenance, as well as to the transport of the unit.

All the accident prevention regulations and standards in force need to be complied with as well, besides complying with the general rules in terms of safety and occupational medicine which are governed by the legislation in force.

The manufacturer declines any responsibility in case of changes made on the machinery without its authorization.

Before commissioning, the buyer must ascertain that ANY equipment or machinery, components and protection installations that are not part of the supply of this machinery comply with Machine Directive 2006/42/CE and to the other applicable European Directives (2006/95/CE - 2004/108/CE, etc.).



	USER'S AND MAINTENANCE MANUAL	Date:	09/04/2024
		Code	MAN D90KA ENG
Motor compressor: D90KA		Revision	06

4 USE OF THE MACHINERY

4.1 Use allowed

The machinery described in this manual is motor compressor D90KA.

The machinery is allocated to work outdoor.

The motor compressor is a piece of machinery with the capacity of generating a given quantity of compressed air in l/m by using a diesel engine as primary energy.

The pneumatic energy finds applications in different fields of use, where "pneumatic" operation tools, accessories and equipment are utilized. For instance: demolition hammers, drilling hammers, vibrators, drilling machines, rammers, coating machines, etc.

Each of these tools/-accessories has its own consumption of compressed air, expressed in litres per minute.

The optimum coupling between the compressor and the tool is achieved when the compressed air consumption does not exceed 85% of the air generated by the compressor (furthermore, it must be taken into consideration that the quantity of compressed air required by the tool shall increase in time, proportionally to the wear of the tool itself).

The correct compressor-tool coupling ratio allows the machinery operating in optimum conditions, as appropriate to ensure long life-span at the highest performance.

An oversized tool - besides creating unfavourable conditions for the appropriate operation of the machinery - shall not develop full performance, since it cannot resort to the required quantity of compressed air.

This machinery has been designed to work at ambient temperature ranging from -10°C (14°F) and +40°C (105°F).



WARNING: *It must be highlighted that the compressed air generated by this unit may contain some very fine traces of oil, therefore it is not appropriate to be utilized with those systems that call for fully oil-free air (e.g.: food processing and pharmaceutical industry, transports of flours and powders, cement, etc...).*

4.2 Use not allowed

It is not allowed to use the machinery for other processes than those which are mentioned in the section above. ELGI declines any responsibility as related to injuries or accidents due to lack of compliance with the specific provisions for use.



	USER'S AND MAINTENANCE MANUAL	Date:	09/04/2024
		Code	MAN D90KA ENG
Motor compressor: D90KA		Revision	06

4.3 Residual risk



Avoid standing in front of the compressed air discharges. The direct exposure to the air jet may cause medium severity injuries because of the strength and speed of the compressed air.



The machine must operate outdoor, because of the presence of the engine and of the relevant exhaust gases.



It is strictly forbidden to operate the machine in indoor environments whose atmosphere is made of vapours or mixtures of corrosive or explosive gases.

When performing demolition, drilling, sandblasting activities or any other operation that generates dust the tool needs to be connected to the compressor through a pressure-resistant hose of sufficient length to keep the machinery away from the work area, thus preventing the clogging of both the exhaustion filters mounted on the unit and of the radiator for the cooling of the lubrication and cooling liquids. Even in this case, a good operator will locate the machinery leese side versus the work area.

The machinery has been designed and built to work with the hood closed and - consequently - it is forbidden to keep it open when the engine is on, because - besides generation harmful sound emissions - the required internal ventilation would be interrupted, and this is instead indispensable for the appropriate operation of the compressor.

Make sure that the hood is closed, as well as the hinges located on the rear side of the motor compressor.



Figure 4.3-1 Engine compartment hood closing hinges

Even selecting the hoses to connect the machinery to the tool, make sure that they are sized as appropriate, taking into account their length, the volume of air which needs to pass through them and the service pressures: if the hoses show a too small diameter or excessive length, the air flow would interrupt, with subsequent loss of load and poor performance of the tool.

The hoses which convey compressed air to from the machinery to the tool, or to any device applied, is to be provided with a tap located at the end which is connected to the tool; the tap shall be held closed during the connection of the hoses to both the machinery and the tool in order to prevent an inappropriate opening of the tap on board the machine from generating strong flickering of the piping, which may cause injuries. Before disconnecting any hose, make sure there is no pressure inside.



	USER'S AND MAINTENANCE MANUAL	Date:	09/04/2024
		Code	MAN D90KA ENG
Motor compressor: D90KA		Revision	06

5 LEVELS AND QUALIFICATIONS OF THE PERSONNEL

The actions on the machinery must be performed by qualified, trained and informed personnel only. "Qualified personnel" means people who - based upon their profession - have acquired experience and instructions as well as knowledge on the relevant standards and provisions on accident prevention and operational conditions. Such personnel, appointed by the machinery safety managers, must be able to perform the required operations as well as to recognize and anticipate the potential hazards.



Entrust the activities to appropriately trained or instructed personnel only; determine unmistakably the competences of the personnel as related to the fine tuning and to the maintenance and repair activities.

Define the responsibility of the operators appointed to run the equipment, also through accurate written provisions and authorize them to reject provisions by third parties if in conflict with the safety regulations and standards.

Make sure that the activities are performed by purposely-appointed personnel only.

The actions on the electrical equipment of the machinery can be performed - in compliance with the electro-technical regulations and standards - only by qualified electricians or by people with an appropriate level of competences in the electro-technical field.

The mechanical and pneumatic maintenance can be performed by the operators of the authorized workshops only.

6 SAFETY PROVISIONS

6.1 Safety provisions concerning transport

The motor-compressors which are not certified for towing need to be loaded onto another means of transport. The motor compressor shall have to be attached as appropriate to the floor of the means of transport in order to prevent and unbalancing of the load during transport.

The unit is shipped attached to a support appropriate for its handling by means of fork-lift trucks; such wooden platform facilitates the anchorage to the floor of the transport vehicle and prevents the load from sliding. For safe transport, operate as follows:

- 1) Locate the unit with the towing steer opposed to the cockpit of the transport vehicle.
- 2) Locate the towing bar as in Figure 5.
- 3) Make the ropes pass around the towing bar and tighten them by means of the winches provided with the means of transport.
- 4) Set two wedges (Part A Figure 6.1-1) on each wheel, attaching them to the vehicle floor, in order to prevent the machinery from moving. Utilize wedges of appropriate sizes, both in height and in width.
- 5) Travel at moderate speed.

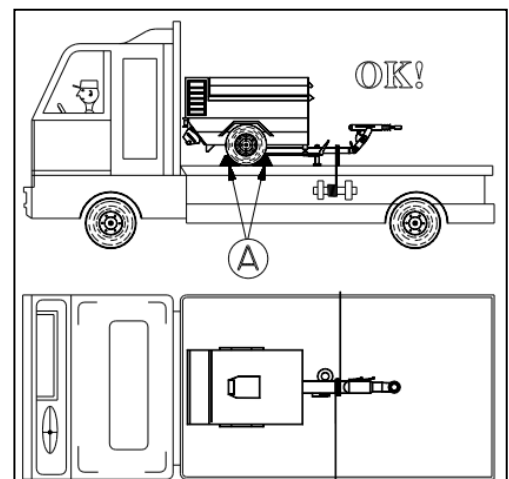

Figure 6.1-1 Instruction for towing in safe conditions



6.2 Safety provisions concerning lifting

A purposely-allocated opening, protected by a rubber membrane, is obtained in the upper panel of the hood and allows for easy access to the lifting hook.

List of the operations for the safe lifting of the machine.

- 1) Make sure that the lifting organ (crane, hoist, etc.) is of the appropriate payload to the weight of the unit and that it is maintained as appropriate.
- 2) In case of lifting installed on truck, use the side anti-tilting stabilizes of the means.
- 3) Attach the hook of the lifting means to the hooking point of the compressor (Figure 6.2-1).
- 4) Lift the unit slowly and without sudden pulls. In the side displacements, prevent the load from swaying excessively.

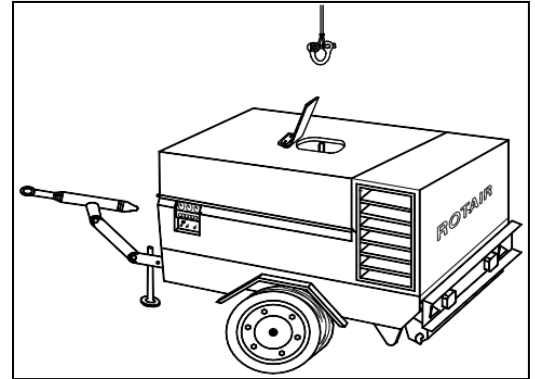

Figure 6.2-1 Lifting system of the machinery



The user must periodically check the efficiency of the lifting equipment and replace it if it results to be no longer appropriate or safe.

No other hooking and lifting systems are allowed except those which are provided with the machine.



This pictogram allows pointing out the hooking system to lift the machine.

- 5) Always check - before handling - that there are no moving parts that may fall. In such case, attach them as appropriate.
- 6) Check the status of ropes and chains before starting the handling operations.
- 7) In any case, always make sure that the machine is solidly fixed to the rope and balanced as appropriate.
- 8) Communicate the start-up of the maneuver as appropriate.
- 9) Never leave the maneuver area with an overhanging load
- 10) Do not stand or transit under the overhanging load.



**WARNING
OVERHANGING
LOADS**



6.3 Safety provisions relevant to towing (for road-certified compressors only)

This paragraph concerns the machinery enabled to road circulation and therefore provided with regular certification.

For the appropriate towing of the motor compressor, comply with the following prescriptions:

- 1) Make sure that the large towing eyebolt or the sphere connection is compatible with the towing device located on the towing vehicle. Make sure that the vehicle is enabled to tow a weight equal to or greater than the one of the motor compressor you intend to tow.
- 2) Check the pressure of the tires.
- 3) Adjust the height of the eyebolt so that it corresponds to the one of the towing vehicle hook; this can be obtained by acting on the articulate joints of the steer, until the towing bar that supports the eyebolt is as horizontal as possible.
- 4) Solidly lock the articulations by means of the appropriate levers, make sure that there is no clearance between the joint teeth.
- 5) Fit the safety plugs.
- 6) Hook the trailer to the vehicle, connecting also the safety cable.
- 7) Release the park brake.
- 8) Lock the foot, or the support wheel, in the highest possible position, making sure that the wheel cannot rotate on itself, and remove the wheel if required.
- 9) Connect the lighting system by introducing the motor compressor plug into the purposely-allocated power outlet located on the vehicle and make sure that all the lights (position, turn, stop, number plate) are operational.
- 10) If the machinery is provided with inertial brake, the latter disengages automatically when maneuvering at reverse speed.
- 11) Periodically check the brakes and - if required - maintain them.

For the maintenance of the towing steer, of the axle and for the adjustment of the brakes, refer to the Manufacturer's manual enclosed to this documentation.

WARNING: To know the maximum speed for towing on the road, refer to the standards in force in the country where the towing is performed. On site or in a towing area, do not exceed the towing speed of 10 km/h.

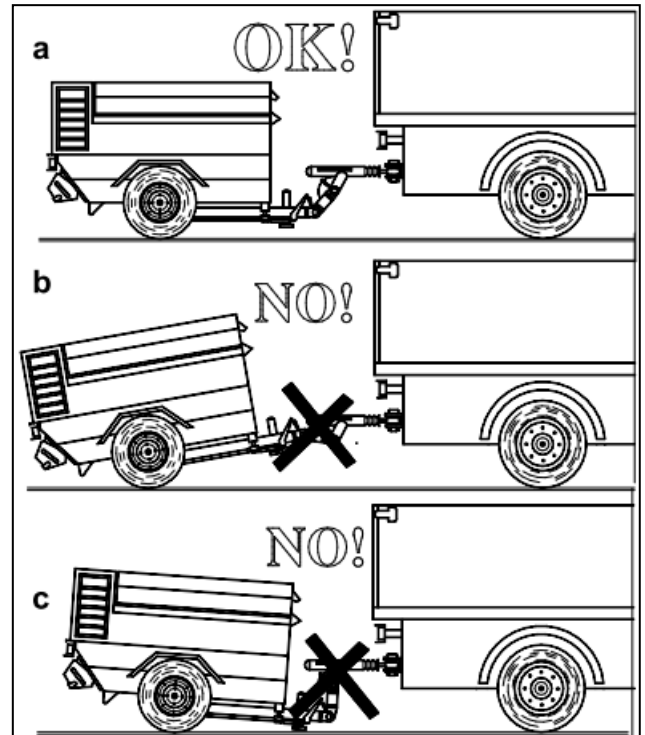

Figure 6.3-1 Instructions for safe towing

	USER'S AND MAINTENANCE MANUAL	Date:	09/04/2024
		Code	MAN D90KA ENG
Motor compressor: D90KA		Revision	06

6.4 Prescriptions for the installation and parking of the motor compressor

Before disconnecting the drawing vehicle, or from the lifting hook, adjust the height of the support foot (Part B Figure 6.4-1) or the pivoting wheel, so that the motor compressor is in horizontal position. In case the machinery is on incline, locate the wedges (Part A Figure 6.4-1) provided with the machine, in front of or behind the wheels to prevent any displacements, which might also occur during the working stage. Engage the park brake, if provided (Part C Figure 6.4-1). It is forbidden to operate with the machine hooked to the towing vehicle.

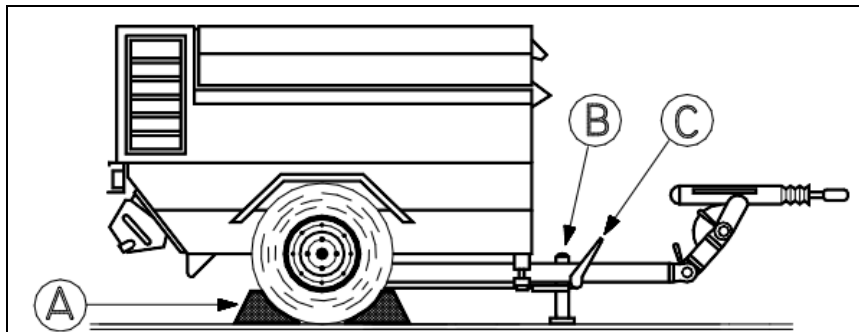

Figure 6.4-1 Instructions for parking and installation of the motor compressor



When parking, it is mandatory to use the support foot, of the hand brake and of the wheel locking wedges.

The lever of the manual parking brake is illustrated hereinafter for the braked version only.



Figure6.4-2 Lever of the manual park brake with release red push-button



	USER'S AND MAINTENANCE MANUAL	Date:	09/04/2024
		Code	MAN D90KA ENG
Motor compressor: D90KA		Revision	06

6.5 Safety provisions concerning maintenance

In order to perform the maintenance operations in safety conditions, the following provisions need to be complied with:

- The control and maintenance operations need to be performed by specialized qualified personnel aware of the indications shown in this manual. "Specialized qualified personnel" means people with the appropriate educational background and whose level of skills is appropriate to the kind of intervention and who have acquired experience and instructions on accident prevention and on the procedures required to perform maintenance operations;
- all the maintenance activities need to be performed after a safe stop of the machine and interrupting power supply to the engine;
- if the machinery is stopped during the maintenance and repair operations, it must be protected against accidental restart;
- in case of replacement of parts, the spare parts must be ordered at ELGI 's customer service and must correspond to the technical standards defined by ELGI;
- the electrical equipment of the machinery must be periodically inspected. Any component's' faults must be immediately pointed out and replaced after careful assessment of their effectiveness and efficiency;
- keep the greatest possible cleanness during the maintenance operations, avoiding using flammable solvents;
- before restarting the machinery after maintenance or overhaul, make sure that all the guards and safety devices are restored and operational.
- never use water to extinguish the flames in case of fire (Figure 6.5-1).



Figure 6.5-1

After performing the maintenance operations, it is mandatory to restore the protections and - in particular -on the area of the cooling fan moving organs



	USER'S AND MAINTENANCE MANUAL	Date:	09/04/2024
		Code	MAN D90KA ENG
Motor compressor: D90KA		Revision	06

6.6 Safety provisions concerning toolbox

The compressor can be equipped with a toolbox to put tools and/or objects inside the machine.

- Before putting any tool and/or object inside the toolbox, make sure you allowed the machine to cool down for a few minutes.
- Avoid to store containers with flammable or non-flammable liquid inside the toolbox.
- If you use the toolbox to store tools and other objects during the compressor handling and/or movement, make sure that the canopy is perfectly locked.

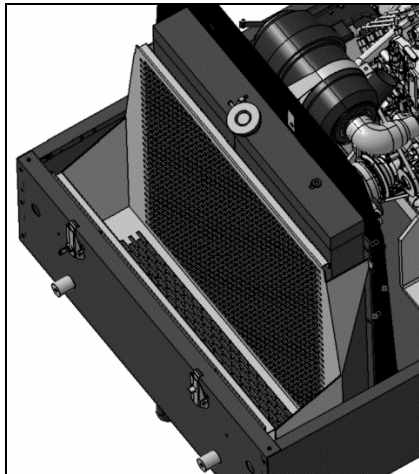

Picture 6.6-1 D185T4I – D185T4F Toolbox

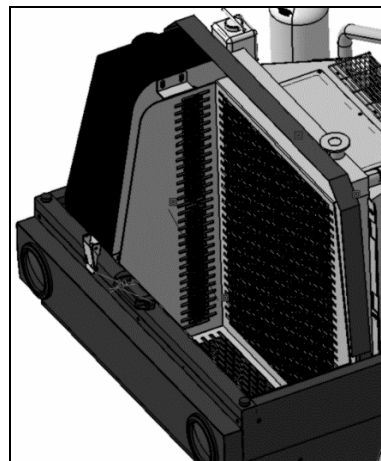

Picture 6.6-2 D90KA Toolbox



WARNING: the toolbox must not have any tool and/or any other object inside before the compressor starting, to grant a perfect air flow allowing the radiator cooling.



The toolbox max loading capacity is 100 lbs (45Kg).



The toolbox has to be used only for the storage and transport of tools and/or objects. **DO NOT** use it while the machine is working for operator's safety reasons.



WARNING: The toolbox, while the machine is working, can reach temperatures that could cause skin burns. Make sure you have properly aired the toolbox before storing any object.



	USER'S AND MAINTENANCE MANUAL	Date:	09/04/2024
		Code	MAN D90KA ENG
Motor compressor: D90KA		Revision	06

7 MACHINERY COMPONENTS

This unit D90KA is a single-phase, silenced oil injection screw mobile motor compressor.

The engine is internal-combustion, fuelled by gas oil, and is connected to the compressor by belt transmission.

7.1 Chassis and axle

The chassis consists of shaped electro-welded sheet metal and is of the bearing frame type. Said chassis is submitted to two paint treatments which ensure resistance against corrosion and rust.

A spring loaded, appropriately axle support the weight of the machine.

It is provided with a towing steer that can be equipped with an eyelet hook, or by a sphere attachment. It consists of articulated elements which allow for the appropriate hooking to the most different towing means.

The motor compressor needs to be certified for towing on road.

The certified version is provided with lighting system with lights for number plate, braking system, and road-type tires sized by the axle manufactured.

The braking system includes the parking brake and the inertial braking system. The both act on the wheel-bearing drums of the axle.

The certified axle is an option supplied upon customer's request.

7.2 Body

The body in galvanized sheet metal is treated by a special painting procedure which ensures optimum finishing quality coupled to the high resistance to impacts and rust.

It is hinged to the chassis and easily tilting thanks to two gas lifters and allows for comfortable access to the main organs of the machinery.

The body is provided with purposely-allocated opening that allow for the inlet of the fresh air required to cool the engine and the compressor and for the exhaustion of the heated air. These openings have been carefully sized and shaped to allow for the most effective internal ventilation of the machinery: it is therefore recommended to take the greatest care to keep these channels free and integer.

7.3 Engine

The unit is equipped with a Diesel engine whose features are described in Section 2.

As related to the user's and maintenance instructions, refer to the manual provided by the Manufacturer and enclosed to the documentation relevant to this machinery.

7.4 Compression unit

This unit is fully manufactured in the plants and it consists of a centre body (cylinder) which host inside two asymmetric profile screw rotors: a 5-lobe male one and a 6-lobe female one.

The cylinder is closed at its end by two heads that contain the bearings which withstand the radial and axial loads generated by the compression of the air.

A set of channels machined in both the cylinder and the heads send oil to the different components. The lubricant that is thus distributed - besides lubricating the bearings - allows keeping a shroud of oil between the rotors and between the rotors themselves and the inner walls of the cylinder, thus fostering tightness to compression. Another significant function of the oil injected between the rotors is the absorption of the heat generated by the compression of the air.

The compressed air supplied by this compressor is pulse-free and the compression is generated axially.

An "adjuster" unit is mounted on the compressor to regulate the quantity of air to let in as a function of the air which is being consumed. Upstream this unit, a double-stage filter ensures the greatest purity of the inlet air.



	USER'S AND MAINTENANCE MANUAL	Date:	09/04/2024
		Code	MAN D90KA ENG
Motor compressor: D90KA		Revision	06

7.5 Separator tank

This is a pressure vessel and - because of its manufacturing characteristics - it does not need to be annually inspected by the body appointed to the verification of the requirements stated in directive 97/23/CE and is provided by the certificate of conformity released by the manufacturer. A nameplate welded on it reports all the identification and testing data.

Its lid is equipped with: the overpressure safety valve and the valve that adjusts the minimum pressure of the machinery.

7.6 Belts and pulley

The gas oil engine is connected to the compressor by belt transmission. The engine and the compressor are installed on a support that ensures their co-axiality and therefore the perfect alignment of the belts to the pulleys. A simple drawing system allows for the accurate tightening of the belts.

7.7 Control panel

The control panel is located on the RH side of the chassis. Protected by a door in transparent polycarbonate, it allows reading the pressure values of the compressed air, of the hour counter as well as the visual check of the pilot lamps, for each of which it will highlight any failures of the machinery organ it is connected to. The control panel contains all the tools required for the control of the machine.



	USER'S AND MAINTENANCE MANUAL	Date:	09/04/2024
		Code	MAN D90KA ENG
Motor compressor: D90KA		Revision	06

8 ELECTRICAL EQUIPMENT OF THE MACHINERY



WARNING: any action on the electrical system must be performed by qualified personnel.

8.1 Operator's panel tools

- 1) Pressure gauge;
- 2) Hour counter;
- 3) Ignition key;
- 4) START/WORK start-up key switch.



Figure 8.1-1 Instrument panel and control devices



	USER'S AND MAINTENANCE MANUAL	Date:	09/04/2024
		Code	MAN D90KA ENG
Motor compressor: D90KA		Revision	06

8.2 Operator's panel pilot lamps

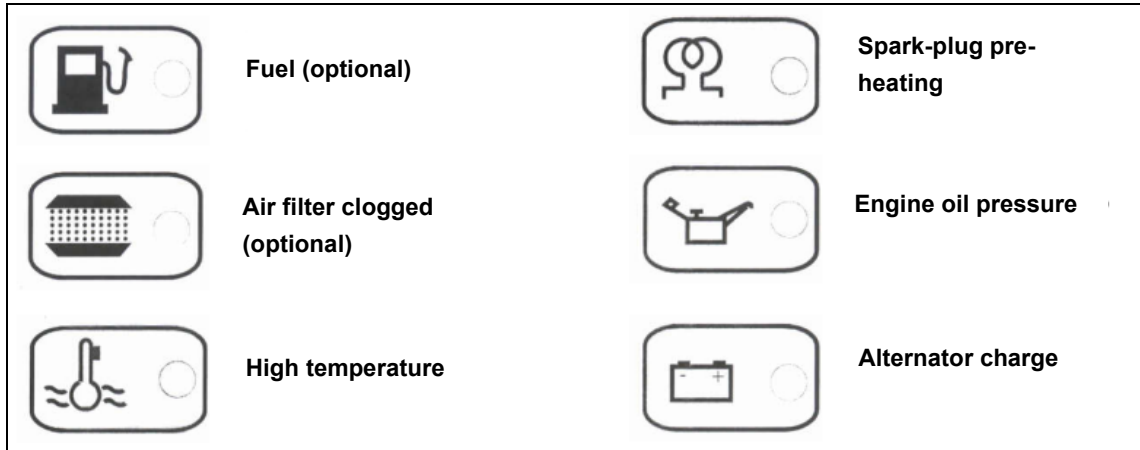

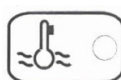





Figure 8.2-1 Pilot lamps



PILOT LAMP	DEFINITION	FUNCTION	OPERATION TO BE PERFORMED	S/O
	FUEL	The fuel lamp highlights the minimum level of fuel in the Diesel tank of the motor compressor	Top up the fuel (Diesel only)	○
	AIR FILTER CLOGGED	This pilot lamp highlights that the air filter is clogged.	Clean the filter or replace it	○
	HIGH TEMPERATURE LAMP	This pilot lamp highlights that the radiator cooling liquid or the compressor oil have reached an excessive temperature	Immediately switch off the machinery and verify the following cases 1) check the liquid level in the radiator and clean it; 2) the cooling liquid pump does not operate as appropriate (contact ELGI customer service); 3) the liquid valve does not close or open at the right moment (replace); 4) if the cooling liquid is leaking, contact ELGI customer service; 5) the radiator is obstructed (contact ELGI assistance).	●
	SPARK-PLUG PRE-HEATING	This pilot lamp remains lit during the pre-heating of the spark-plugs. Wait for the pilot lamp to come off before starting the motor compressor by pushing the ignition push-button. The pilot lamp must be off when the engine is running.	If the pilot lamp is on for a lengthened time, ascertain the state of the ignition spark-pugs and replace them if required.	●
	ENGINE OIL PRESSURE LAMP	This pilot lamp highlights the insufficient pressure of the engine oil. The lamp is off when the engine oil is in pressure Pilot lamp lit: engine oil not in pressure.	The oil pilot lamp highlights the insufficient pressure of the oil. Such insufficient pressure may be caused by: 1) engine oil level check; 2) breakage of the delivery pump; 3) oil not reaching the delivery pump	●
	ALTERNATOR CHARGE LAMP	This pilot lamp monitors the efficiency of the alternator. The pilot lamp must be off when the engine is running.	Should it light up during the normal operation, check the efficiency of both the battery and the alternator.	●

● Pilot lamp operational on the series version ○ Option pilot lamp



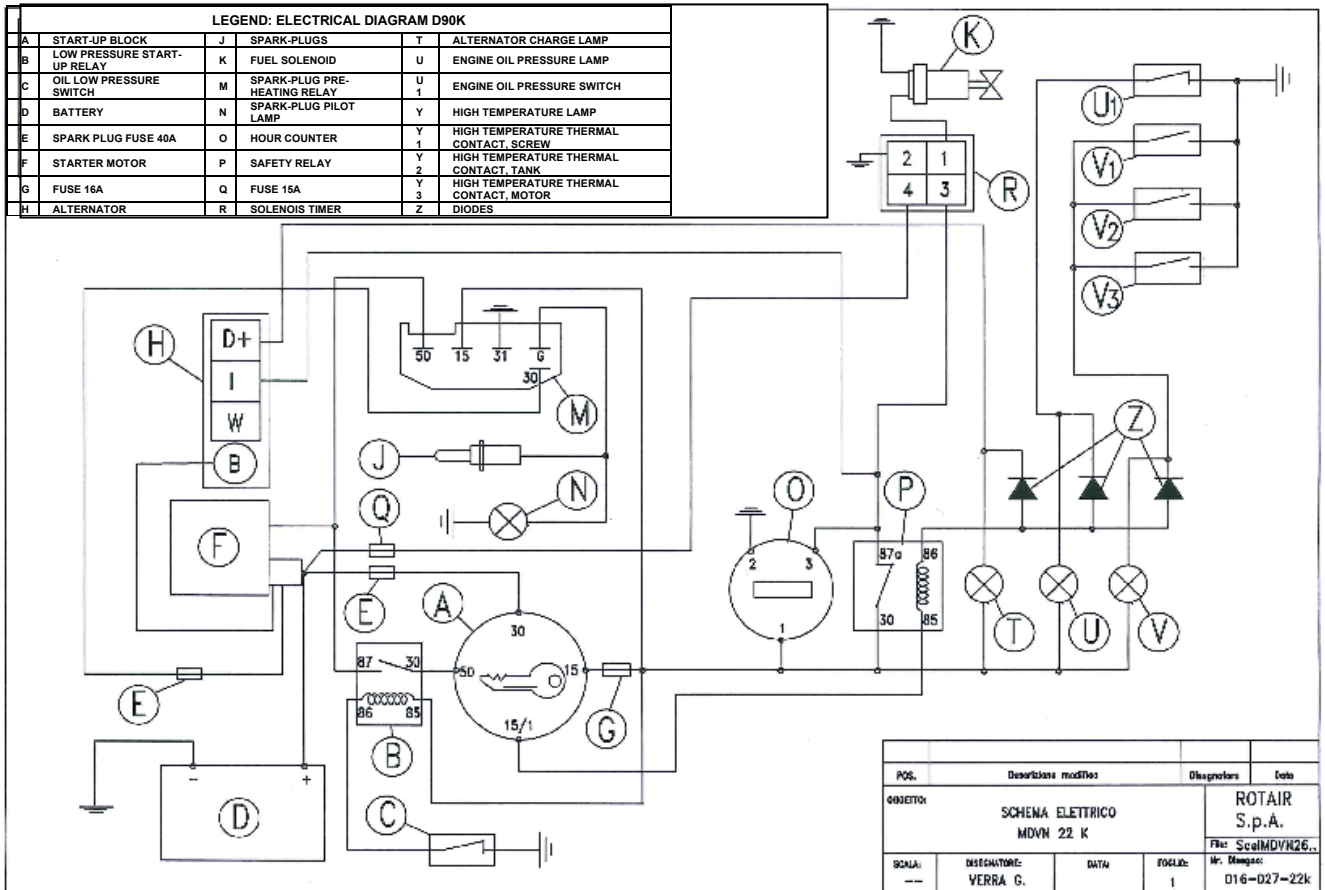

Figure 8.2-2 Diagram 2 machine's electrical system





LEGEND: ELECTRICAL DIAGRAM D90K					
A	START-UP BLOCK	J	SPARK-PLUGS	T	ALTERNATOR CHARGE LAMP
B	LOW PRESSURE START-UP RELAY	K	FUEL SOLENOID	U	ENGINE OIL PRESSURE LAMP
C	OIL LOW PRESSURE SWITCH	M	SPARK-PLUG PRE-HEATING RELAY	U1	ENGINE OIL PRESSURE SWITCH
D	BATTERY	N	SPARK-PLUG PILOT LAMP	Y	HIGH TEMPERATURE LAMP
E	SPARK PLUG FUSE 40A	O	HOUR COUNTER	Y1	HIGH TEMPERATURE THERMAL CONTACT, SCREW
F	STARTER MOTOR	P	SAFETY RELAY	Y2	HIGH TEMPERATURE THERMAL CONTACT, TANK
G	FUSE 16A	Q	FUSE 15A	Y3	HIGH TEMPERATURE THERMAL CONTACT, MOTOR
H	ALTERNATOR	R	SOLENOIS TIMER	Z	DIODES

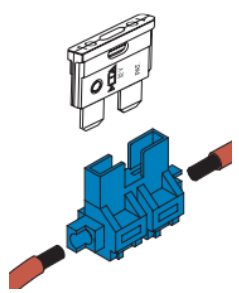

8.3 Fuses

The fuse is an electrical device which can protect a circuit or a device from over current.

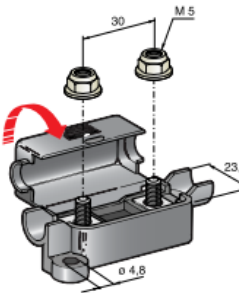
The fuse consists of a cartridge provided by a thin lead wire through which the rated current of the circuit/element transits; this wire is the actual fuse, with a precise Amp load. In case of overcurrent, the filament melts and causes the circuit to open.

Fuse holder	Fuse drawing	Description	Ampere
		<p>Secondary fuse: device to protect against overcurrent which might damage the fuel solenoid</p>	<p>15 A</p>
		<p>Control panel supply fuse: protection device against overcurrent that might damage the control panel.</p>	<p>40 A</p>



WARNING: *When replacing the fuses, we recommend always utilizing the sale type as indicated in this table and to follow the procedure reported in section 13.4.3 of the manual.*

Date:	09/04/2024
Code	MAN D90KA ENG
Revision	06

Motor compressor: D90KA

8.4 Lights (for EU road-certified version)



In the road-certified machinery, the electrical system is completed by the light wiring (Figure 8.4-3). The table here in under reports the connections of the wires within the 7-pole outlet and their connection to the rear lighting equipment. This system is directly connected to the towing machine through an extension supplied with the motor compressor.

Rear lights:

- 1) Turn light
- 2) Position and stop light (stop detected by light intensity)

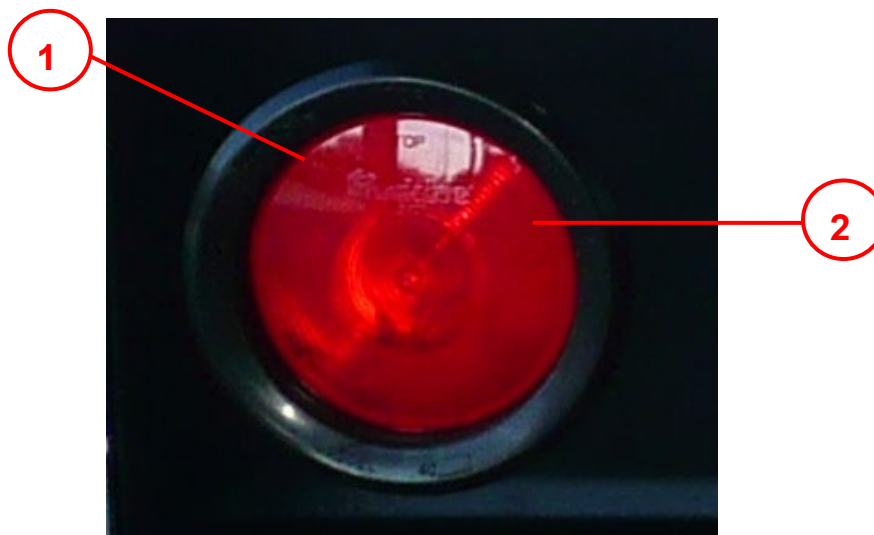
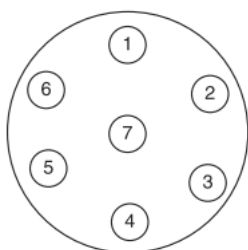

Figure 8.4-1 Rear light

7-POLE PLUG DIAGRAM



- 1) Turn light LH:
- 2) Fog lamp
- 3) Earthling
- 4) Turn light RH:
- 5) Position light RH
- 6) Stop
- 7) Position light LH



WARNING: To replace the lamps, refer to the Maintenance chapter.



Date:	09/04/2024
Code	MAN D90KA ENG
Revision	06

Motor compressor: D90KA

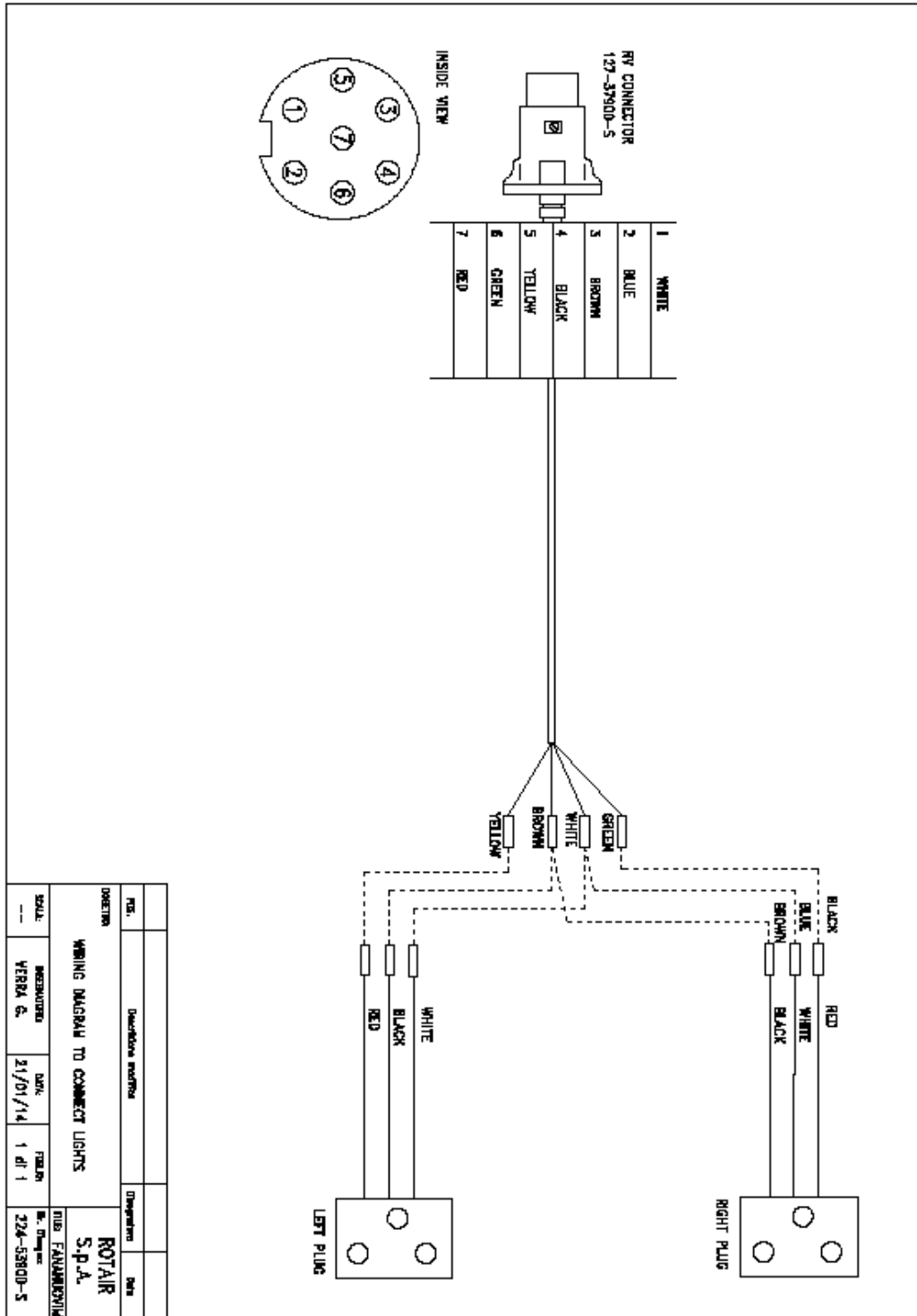

Figure 8.4-3 Light wiring harness



9 HYDRAULIC AND PNEUMATIC SYSTEMS

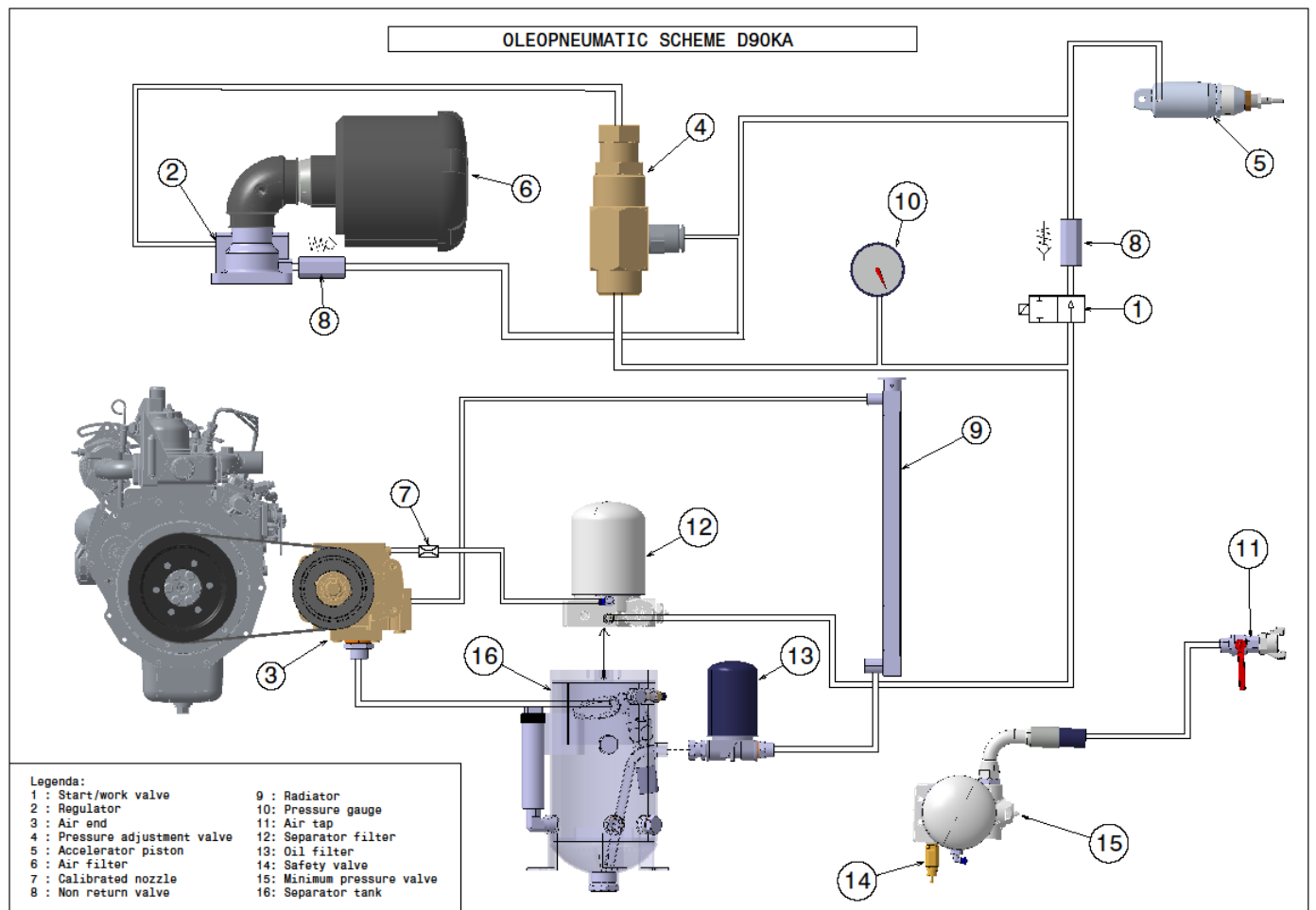

Figure 9-1 Hydraulic and pneumatic systems

9.1 Hydraulic lubrication system

The hydraulic lubrication system (Figure 9-1) of the compressor consists of:

- Separator tank (16);
- Separator filter (12);
- minimum pressure valve (15)
- oil filter (13);
- oil cooling radiator (9);

As you may notice, the lower portion of the separator tank (16) is used as oil tank while the minimum pressure valve located in the upper part (15) operates as a support of the separator filter (12).

When starting up the machinery, the oil under pressure located in the tank starts flowing through the duct into the oil filter (13), and from there to the cooling radiator (9).

The cooled filtered oil then reaches the compressor (3) and - by means of appropriate inner piping - is



	USER'S AND MAINTENANCE MANUAL	Date:	09/04/2024
		Code	MAN D90KA ENG
Motor compressor: D90KA		Revision	06

distributed to the different organs (rotors, bearings, etc.), which are thus lubricated and cooled.

From the compressor (3), the oil -mixed to the compressed air in input from the exhaust valve (2), is sent to the tank (16), where - through a forced centrifugal circuit - the compressed air is submitted to a first separation from the oil.

The resulting compressed air leaves the separator tank through the separator filter (12), which will provide to a second and last separation of the air from the remaining oil.

Even though the separating filter (12) separates the air from the oil, it is worth pointing out that a limited quantity of the latter manages to penetrate inside the filter and deposits on the lower portion of the filter itself.

The oil is sucked into the piping where a calibrated nozzle (7) and a check-valve (8) will route it to the compressor (3).

The check valve (8) shall prevent the oil from retuning into the separator filter (12) when the machinery is stopped.

Attention! The oil filter (13) is provided with a "by-pass" valve which allows the oil to circulate also in case it is clogged. In such case, the oil shall circulate regularly without being filtered.



WARNING: The filter needs therefore to be replaced at regular intervals, as specified in the maintenance program.

9.2 Pneumatic system

The pneumatic system (Figure 9-1) includes:

- start/work valve (1).
- suction filter (6);
- suction adjustment valve (2);
- compressor (3);
- separator tank (16);
- separator filter (12);
- the min. pressure and check valves integrated in the composed valve (15)
- tap (11);
- Max. pressure record valve (4);

The sucked air, after passing through the air filter (6), reaches the suction adjuster (2) and then the compressor (3), which - after compressing it - conveys it -together with the injected oil - into the separator tank (16). Here the air is separated from the oil. This process - as indicated above - is made first of all by centrifugal force and then by the use of the separator filter (12).

Once the air is purified from the oil, is conveyed to the minimum pressure valve (15), which opens only when the pressure in the tank has reached the established value.

It is in any case a good practice not to use tools that - with their excessive consumption - may cause the lowering of the pressure in the tank under 5/5,2 bar. Lengthened working conditions below 5 bar may create insufficient separation of oil from air, with a subsequent anomalous consumption of lubricant.

Furthermore, the min. pressure valve (15) acts as a check valve, thus preventing the return into the unit of compressed air coming from piping or tools connected to the machinery.



WARNING: pressure vessel



	USER'S AND MAINTENANCE MANUAL	Date:	09/04/2024
		Code	MAN D90KA ENG
Motor compressor: D90KA		Revision	06

9.2.1 AUTOMATIC ADJUSTMENT OF THE ENGINE RPM

The system controls the Diesel engine rpm as a function of the compressed air retrieved and includes:

- Max. Pressure valve (4);
 - Suction adjustment valve (2);
 - Accelerator control piston (5)
- With the engine running and the tap (11) fully open, the engine rpm are at the max. value and the suction adjuster is fully open.
 - Partially close the tap (11) to simulate a reduction in the air consumption with subsequent increase of the pressure in the tank (A).
 - When the tap (11) is progressively closed, the pressure reaches the established adjustment value and the max. pressure valve (4) ones letting the compressed air flow out and act - at the same time - on the accelerator control piston (5) and under the suction adjuster valve (2).
 - Under the action of such pressure the piston (5) proportionally decelerates the engine.
 - At the same time, the suction adjustment valve (2) proportionally closes as well, thus reducing the passage of the air which is being sucked. Consequently, with the tap (11) closed and - subsequently - without any air retrieval, the engine shall stabilize at the minimum rpm it was adjusted for, while the suction valve (2) of the adjuster shall move to an almost total closing position.
 - At this stage of the cycle, the sucked air is minimum and is used to compensate for any leakages and internal leakages of the circuit.
 - The pressure gauge on the control panel shall display the value of the max. final pressure.
 - When air is resumed to be retrieved, the max. Pressure valve (4) shall start closing again and shall be totally closed once the pressure valve lowers by approx. 1 bar versus the value of the max. final pressure.
 - At this stage, the compressor delivers the max. rate at the service pressure, since the internal spring of the accelerator piston (5) accelerate the engine up to the max. Speed, and the suction adjustment valves is the full opening position.
 - If tools of greater consumption that the rated capacity of the compressor are used, the pressure gauge shall display a lowering of the pressure which - in any case - must never be lower than 5 bar.
 - Avoid sudden openings of the taps: they generate strong stress to the separator filter, with subsequent severe damage to the filter itself.



	USER'S AND MAINTENANCE MANUAL	Date:	09/04/2024
		Code	MAN D90KA ENG
Motor compressor: D90KA		Revision	06

10 PROVISIONS FOR THE APPROPRIATE UTILIZATION OF THE MOTOR COMPRESSOR

Consult this user's and maintenance manual before starting-up the machinery.

10.1 Before starting-up

Before starting-up the machinery, strictly follow the instructions here in under:

1. Level the planarity of the machine by acting on the support foot or on the wheel: no incline greater than 15° is allowed;
2. make sure that the electric wires are connected to the battery terminals; if the connection is to be performed, use the greater care so that the cable coming from the starter motor is connected to the positive pole (+) of the battery and the earthing one is connected to the negative pole (-) of the battery.
3. Check the fuel level in the tank*.
4. Check the level of the engine oil: as related to the types of lubricant and relevant quantities, comply with the prescriptions contained in the engine manufacturer's users and maintenance manual enclosed to the machinery documentation.
5. Check the oil level in the compressor: this operation must be performed not before than five minutes have passed from the time the machinery was stopped, and this to allow the lubricant in circulation to flow completely into the separator tank.
 - a) Before unscrewing the filler plug where the level gauge is attached, make sure that there is no longer pressure in the system. (The pressure gauge shall indicate 0 bar).
 - b) Take off the plug and clean the level gauge.
 - c) Thoroughly screw back the filler plug and then take it off again to verify that the lubricant level is included between the two marks (min. and max. level) engraved on the gauge.
 - d) Top up if required: the level must never exceed the max. mark.
 - e) Exclusively utilize the types of oil recommended in this user's and maintenance manual.



Figure 10.1-1 Checking the oil level in the compressor



DIESEL

* Only use Diesel fuel for topping up.



	USER'S AND MAINTENANCE MANUAL	Date:	09/04/2024
		Code	MAN D90KA ENG
Motor compressor: D90KA		Revision	06



Figure 10.1-2 Fuel tank for Diesel engine

- 6 If the motor compressor is equipped with a liquid-cooling diesel engine, check the level of the cooling liquid contained in the radiator (Figure 10.1-3).



Figure 10.1-3 Checking the radiator cooling liquid

Recommended cooling liquid: ROLOIL ROL-ICE BLU



WARNING: *the radiator plug (Figure 10.1-3) must never be removed when the engine is hot: this would cause a sudden outflow of liquid which might cause severe scalding. Topping up - if required - must be made by means of a blend of water and anti-freeze liquid, in the percentage indicated on the container of the latter.*

10.2 Start-up

Operations to be performed for a correct start-up of the machinery:

- 1) Completely close the air exit valves.
- 2) Take the Start/Work key switch (Part 3 Figure 8.1-1) onto the Start position.
- 3) Turn the ignition key (Part 4 Figure 8.1-1) to the first trigger to supply the control panel. The spark-plug pre-heating and oil pressure lamps shall light up.
- 4) Wait for the spark-plug pre-heating lamp to switch off, turn the start-up key (Part 4 Figure 8.1-1) until the engine starts.



WARNING: *Release the key at the first signs that the diesel engine is starting. Do not run any lengthened starts, above 10 seconds. In case of difficult start-up, repeat the maneuver with short start-ups at intervals.*



	USER'S AND MAINTENANCE MANUAL	Date:	09/04/2024
		Code	MAN D90KA ENG
Motor compressor: D90KA		Revision	06

- 5) When the engine is started and the key switch is still on Start position, the engine shall turn at the minimum rpm; the pressure gauge highlights a pressure included between 2 and 3 bar, while all the pilot lamps on the control panel must be off.
- 6) Wait for a few minutes, until the engine warms up, then move the Start/Work key switch (Par. 3 Figure 8.1-1) on Work position. The pressure shall raise up to the max, pressure of the machinery. If one or more lamps were still lit, immediately stop the machinery and identify the cause.
- 7) Then connect the compressed air ducts to the relevant tools.
- 8) Progressively open the exit valves (Letter A Figure 10.2-1).



WARNING: *It is forbidden to open the machinery with the engine hood open.*

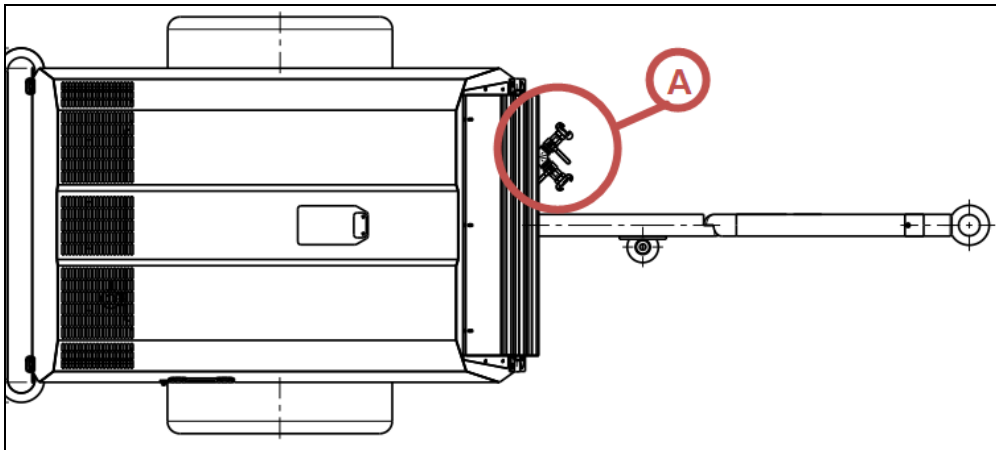

Figure 10.2-1 Location of the air exit valves (top view)



Figure 10.2-2 End of the pneumatic connection of the tap with safety plug



WARNING: *Do not breathe the compressed air produced by this unit in output from the taps*



	USER'S AND MAINTENANCE MANUAL	Date:	09/04/2024
		Code	MAN D90KA ENG
Motor compressor: D90KA		Revision	06

10.3 During the work cycle



The machine must always operate with the hood down and closed.

During the work cycle it is necessary to verify that the intake openings are free of foreign bodies such as pieces of paper, plastic, etc ... as these materials can create obstructions to the ventilation system.



Figure 10.3-1 Exhaust pipe



WARNING: *in the vicinity of the exhaust pipe are very hot exhaust gases and harmful. Avoid the stop in the vicinity of the exhaust pipe*

10.4 Stop

- 1) Completely close the exit valves.
- 2) Turn the selector (Part 3 Figure 8.1-1) on the position "Start". the pneumatic pressure is discharged
- 3) When the pressure drops to 3 bars stop the compressor by turning the key counter clockwise position 0.

10.5 After stopping the machine

- 1) If the machine has operated in dusty environments, it will be necessary to clean or replace the air filter and check the status of cleaning the cooling radiator; where this is clogged, it will proceed as indicated in paragraph maintenance.
- 2) Check that during the working phase there are no losses of fuel or lubricating oil inside the machine
- 3) Where possible place the machine away from the elements.



	USER'S AND MAINTENANCE MANUAL	Date:	09/04/2024
		Code	MAN D90KA ENG
Motor compressor: D90KA		Revision	06

11 MONITORING AND TESTING OF THE MACHINE

11.1 Monitoring and testing of engine speed



ALL TESTING AND CALIBRATION SYSTEMS MINIMUM AND MAXIMUM, MUST BE DONE BY A PROFESSIONAL, INFORMED, FORMAT AND TRAINED, EQUIPPED WITH A SPECIAL EQUIPMENT TACHYMERIC A STRIKER REFLECTIVE AND EQUIPPED WITH HEADPHONES NOISE.



For all calibrations and adjustments we highlight the following residual risks



Presence of organs of motion. Pay attention to mechanical risks.



The presence of hot surfaces at high temperatures. Pay attention to the risk burn.



11.1.1 CONTROL SYSTEM OF MAXIMUM ENGINE SPEED



The calibration of the maximum speed is set by the manufacturer. It should not be changed for any reason. Any tampering or variation of the maximum speed of rotation of the motor will cause an immediate voiding of the warranty.

11.1.2 CONTROL SYSTEM OF MINIMUM ENGINE SPEED

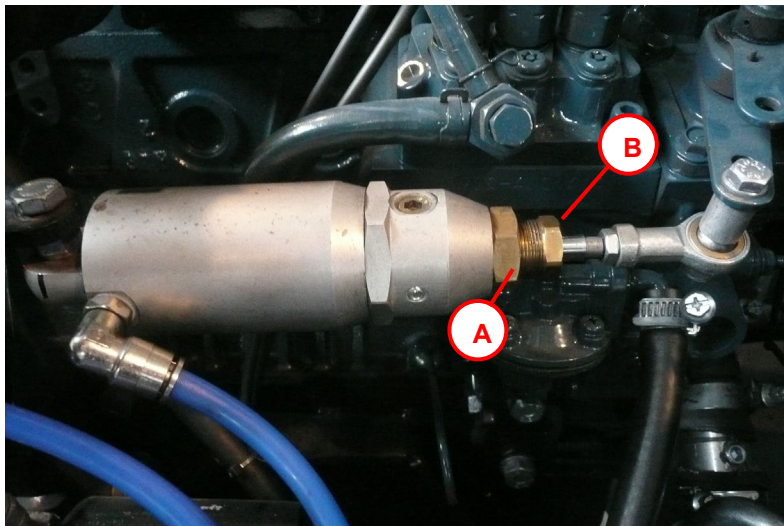

Figure 11.1-1 Adjusting idle speed motor

For calibration of the idle speed of the engine revs qualified maintenance personnel must do the following:

1. Start the machine as described in section 10.2 "Start"
2. Wait for the compressor reaches the maximum pressure and the engine stating the values of idle speed;
3. Close all faucets (Letter A in Figure 10.2 1);
4. Open the bonnet with the compressor in motion;
5. Unscrew with wrench 23 mm, the nut (Letter A in Figure 11.1 1);
6. If you want to increase the idle speed of the engine, you must tighten the lock nut by an 18-mm wrench (Letter B in Figure 11.1 1).



	USER'S AND MAINTENANCE MANUAL	Date:	09/04/2024
		Code	MAN D90KA ENG
Motor compressor: D90KA		Revision	06

7. If you want to reduce the idle speed of the engine, you must loosen the lock nut by an 18-mm wrench (Letter B in Figure 11.1 1).
8. Measure with a optical tachometer (Letter B in Figure 11.1 2) the speed of rotation (in revolutions / minute) of the motor hub focusing the optical beam on the speedometer notch Reflective (Letter A in Figure 11.1 2);
9. Compare the measured value with that reported in Paragraph 2 a tolerance of $\pm 2/3\%$ between the two values
10. Adjust the speed of the motor hub, as described above, to the value of idle speed indicated in paragraph 2 of this manual;
11. Once the adjustment screw, with a 23 mm wrench, nut (Letter A in Figure 11.1 1);
12. Close the bonnet.

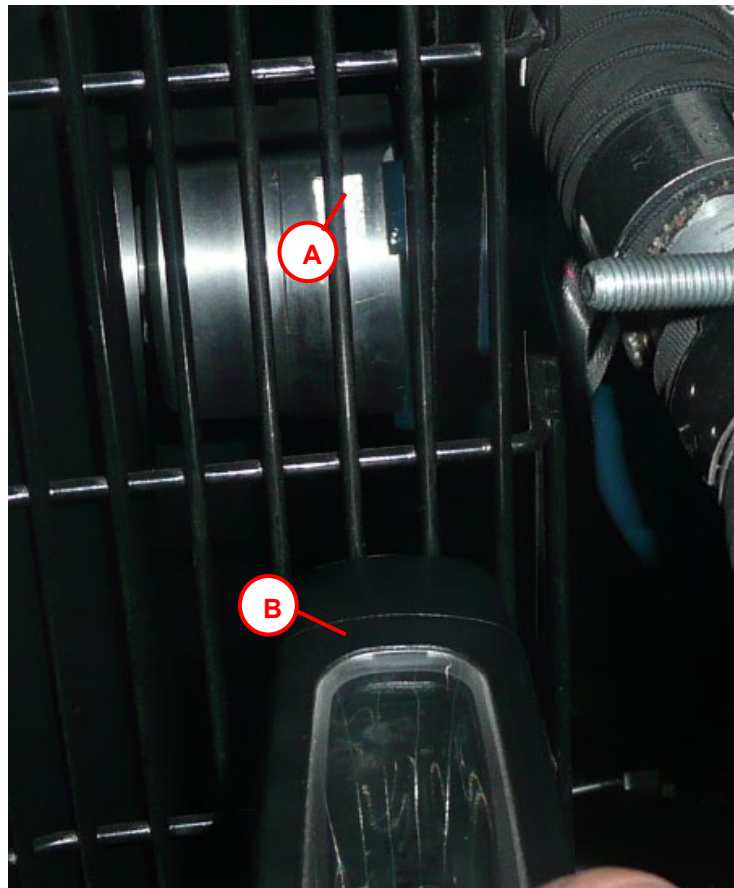

Figure 11.1-2 Measurement speed rotating motor hub

	USER'S AND MAINTENANCE MANUAL	Date:	09/04/2024
		Code	MAN D90KA ENG
Motor compressor: D90KA		Revision	06

11.2 Monitoring and control of the air pressure of the compressor

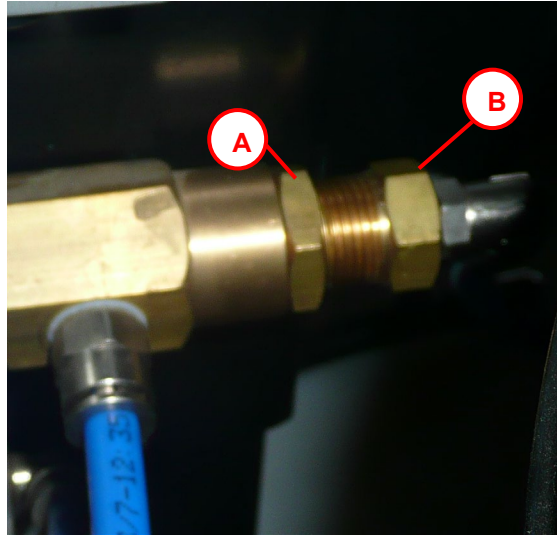

Figure 11.2-1 Adjusting maximum pressure pneumatic circuit

The maximum pneumatic pressure is calibrated during the testing phase of the machine.

If the value of the maximum pressure pneumatic, indicated by the pressure gauge on the control panel, diverged over a $\pm 5\%$ from the value specified in Paragraph 2 of this manual, proceed as follows:

1. Start the machine as described in section 10.2 "Start",
2. Wait for the compressor reaches the maximum pressure and the engine stating the values of idle speed;
3. Close all faucets (Letter A in Figure 10.2-1);
4. Open the bonnet with the compressor in motion;
5. Unscrew with wrench 22 mm in, the nut (Letter A in Figure 11.2-1); Air filter area:
6. If you want to increase the maximum pressure must tighten with 19 mm wrench, nut (Letter B in Figure 11.2 1);
7. If you want to reduce the regime min unscrew, with a 19 mm wrench, nut (Letter B in Figure 11.2-1);
8. Once the adjustment screw, with a 22 mm wrench, nut (Letter A in Figure 11.2-1);
9. Slightly open for 3/4 seconds, the air exit valve to the engine to accelerate, and then close it. Repeat this 2-3 times to allow the settling of the valve.
10. Reading on the pressure gauge located in the control panel, the value of the maximum pressure reached;
11. Compare the measured value with that reported in Paragraph 2, repeat the steps up to the alignment of the two values;
12. Close the bonnet.



WARNING: Notice: if the gauge had a discontinuous, jerky, you will have to replace it. So, before making any calibration valve high or low pressure, make sure that the gauge is efficient and reliable.



	USER'S AND MAINTENANCE MANUAL	Date:	09/04/2024
		Code	MAN D90KA ENG
Motor compressor: D90KA		Revision	06

11.3 Monitoring and control of air pressure minimum compressor

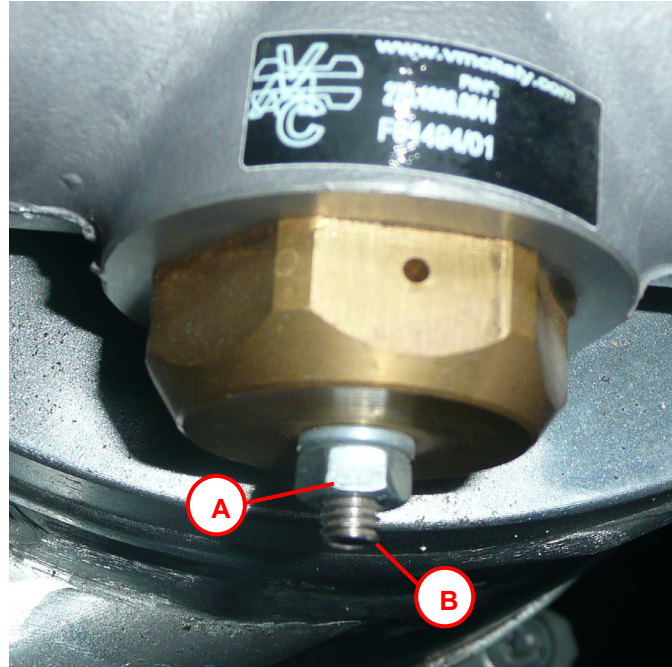

Figure 11.3-1 Adjusting minimum pressure pneumatic circuit

The minimum pneumatic pressure is calibrated during the testing phase of the machine.

If the minimum pressure pneumatic, indicated by the pressure gauge on the control panel, diverged over a $\pm 5\%$ from the value specified in Paragraph 2 of this manual, proceed as follows:

1. Start the machine as described in section 10.2 Start.
2. Wait for the compressor reaches the maximum pressure and the engine stating the values of idle speed;
3. Gradually open the air valve (Letter A in Figure 10.2-1);
4. Open the bonnet with the compressor in motion;
5. Unscrew, with 10 mm wrench, nut (Letter A Figure 11.3-1) located in the vicinity of the exhaust cleaner. Please Translate These points.
6. If you want to increase the maximum pressure must tighten the Allen screw (Figure 11.3-1 Letter B) with Allen key 3 mm;
7. If you want to reduce the regime min loosen the Allen screw (Figure 11.3-1 Letter B) with Allen key 3 mm;
8. Once the adjustment screw, with a 10 mm wrench, nut (Letter A Figure 11.3-1) and turn off the taps;
9. Reopen slowly the air tap (Letter A Figure 10.2-1) and close it again repeating the process a few times to allow the settling of the valve;
10. Close the bonnet.



WARNING: *Pressure vessel*



	USER'S AND MAINTENANCE MANUAL	Date:	09/04/2024
		Code	MAN D90KA ENG
Motor compressor: D90KA		Revision	06



12 SAFETY DEVICE (ONLY EU VERS.)

PRESENT	SAFETY DEVICE	FUNCTION
	Top buttons with rearmament rolling (fungus)	Immediate stop of the machine. Intervenes by switching off power to the electrical circuits.

12.1 Emergency stop buttons

On board the machine is installed an emergency stop button with self-restraint type "fungus" according to EN 418, red or yellow with priority in all operating modes with respect to other functions and activations. In case of need the machine can be locked immediately by pressing the emergency button. After pressing the power supply is cut.

12.1.1 OPERATION OF THE EMERGENCY BUTTON

	Press this button to stop the machine in emergency conditions. WARNING: Use only for emergency and not to turn off the machine normally.
	To restore the normal working conditions, in the event of an emergency stop due to the pressure of the above buttons, the following procedure should be followed: <ul style="list-style-type: none"> Remove the cause that prompted the shutdown of the machine; Turn out the emergency stop button pressed; Operate the power switch turning off and on the machine.



	USER'S AND MAINTENANCE MANUAL	Date:	09/04/2024
		Code	MAN D90KA ENG
Motor compressor: D90KA		Revision	06

12.2 Verification of the safety valve

The safety valve is located on the oil separator tank and starts working to download any accidental overpressure.

The calibration of this valve is performed and verified in the testing of the factory and cannot be varied for any reason or tampered with.

Its efficiency should be checked quarterly by doing the following:

- 1) Start the machine the machine as described in section 10.2 "Start"
- 2) With the valves closed and with the engine at idle speed, using forceps, pick up the pin, as shown in Figure and release it as soon as you have the perception that the valve exhausts air.

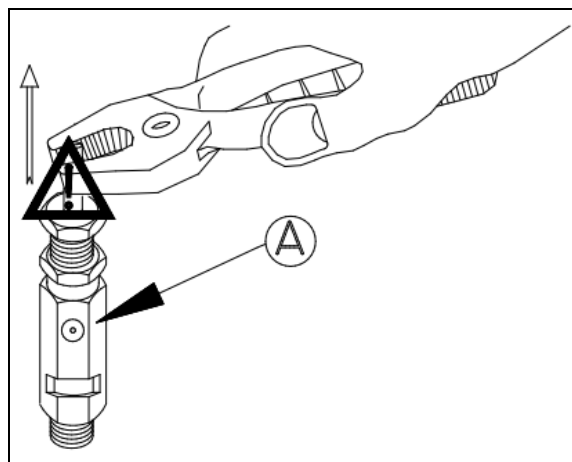

Figure 12.2-1 Control of the safety valve



WARNING: *The air escaping from the valve during this operation control is also composed of small particles of oil.*



WARNING: *Pay attention to the danger of projection of liquids.*



If, following the traction using a clamp, the pin is not raised, thus preventing the valve to vent, will require an immediate replacement of the same.



In case of replacement, it is recommended to contact the service ELGI, quoting the serial number of the machine.

The use of a safety valve is not original and does not comply, the ELGI exempt from any liability.



	USER'S AND MAINTENANCE MANUAL	Date:	09/04/2024
		Code	MAN D90KA ENG
Motor compressor: D90KA		Revision	06

13 MAINTENANCE



The machine must be subjected to regular periodic maintenance in order to keep unchanged the technical characteristics, and safety originate.

Maintenance work must be performed by qualified personnel of patterns and designs, the machine stopped and power switched off to the electrical panel. Therefore, all maintenance must be carried out only after turning off the machine.



The staff of the service maintenance has to check that they have withdrawn their tools at the end of surgery and before starting the machine again, to avoid damage to the moving parts.

13.1 Routine maintenance

Means with **routine maintenance**, all the maintenance actions that its sole objective was to bring back a system (or one of its components) from a state of failure, the state is working properly before the onset of the problem, without changing or improving the functions performed by the system, nor to increase the value, or improve performance.

Maintenance includes all those periodic operations including:

In the following chapter are listed in order of frequency, all transactions concerning the compressor part, while as regards the part of the engine, it will be necessary to refer to OPERATING AND MAINTENANCE, which is prepared by the manufacturer of the engine and that is as supplied with the machine



	USER'S AND MAINTENANCE MANUAL	Date:	09/04/2024
		Code	MAN D90KA ENG
Motor compressor: D90KA		Revision	06

13.2 Maintenance program

In this program are listed all the interventions and their frequency to be executed on the various components of the machine. Such interventions are essential for the proper functioning of the machine and its mechanical durability over time.

<i>RECOMMENDED OPERATIONS</i>	<i>FREQUENCY</i>
Checking the oil level compressor	Daily
Check engine oil level (refer to the manufacturer's manual)	Daily
Checking Coolant Level	Daily
Check fuel level and top up (if necessary)	Daily
Check oil or fuel leakage	Daily
Check operation indicator lights	Daily
Check the readability of measuring instruments	Daily
General cleaning operations	Daily
Control of the absence of obstructions to the ventilation system	Daily
Control of the air filter Compressor	weekly
Control air filter in dusty work conditions	Daily
Check operation lights and license plate lights (only for the approved version of the road)	Daily
Control of the air filter Compressor	weekly
Control of the engine air filter	(Ref. Manual of the engine manufacturer).
Checking the battery electrolyte level	Monthly
Checking tire pressure	Monthly
Checking belt tension Quarterly	Three months
Speed control the minimum and maximum engine	Three months
Control of the efficiency of the safety valve	Three months
Cleaning the oil cooler	Three months
Control nozzle oil recovery	Three months
Drainage of the fuel tank	Three months
Replacing diesel pre-filter	Every 500 hours
Control of the efficiency of the braking system	Three months
Control and wheel lock	Three months

	USER'S AND MAINTENANCE MANUAL	Date:	09/04/2024
		Code	MAN D90KA ENG
Motor compressor: D90KA		Revision	06

RECOMMENDED OPERATIONS	FREQUENCY
Change engine oil	(Ref. Manual of the engine manufacturer).
Oil Filter Replacement compressor	After the first 50 hours
Replacing compressor oil	After the first 50 hours
Control of tightening screws and bolts of the compressor and engine silent-blocks	Every 50 hours
Control of tightening screws and bolts	Every 100 hours
Check tightness of all pipe connections	Every 100 hours
Replace Air Filter Compressor	After 500 hours
Replace oil filter compressor	After 500 hours or after a long storage period (9-12 months) whichever comes first
Replacing compressor oil	After 1500 hours
Replacing oil separator element	After 2000 hours
Check-up by the service "authorized ELGI".	Every 3000 hours
Control readability nameplate EC Annual	Annual
Control valves from service "authorized ELGI".	Biennial



The ELGI disclaims any responsibility for the failure to comply with maintenance requirements in the table above.

	USER'S AND MAINTENANCE MANUAL	Date:	09/04/2024
		Code	MAN D90KA ENG
Motor compressor: D90KA		Revision	06

13.3 Values of tightening screws and bolts

For the correct tightening of screws and bolts on the machine please observe the tightening values corresponding to the class of coupling illustrated in the table below.

We recommend the use of torque wrenches for tightening the screws and bolts on the machine.

Torques not binding N.m (Newton meters)							Couples test sockets for hexagonal screws									
<p>These pairs are reference values for normal metric threads according to DIN ISO 261 and measures supporting heads according to DIN EN ISO 4762, DIN ISO EM 4032, DIN EN ISO 4014 and DIN 931-2, 6912, 7984 and 7990. With these values obtains an exploitation of 90% of the yield strength of the screws, on the basis of a coefficient of friction equal to 0.14 (screw new, untreated, not lubricated). Important: In extreme cases, e.g. screws lubricated with MOS2 and coupling elements cadmium-plated on both sides, the value of torque should be reduced by about 20%.</p>																
														No. 2, 2A, 2B No. 1B, 308, 7	No. 4	No. 6, 1B, 7, 400
	Tightening values for classes of coupling according to DIN 267															
	4.6	5.6	6.9	8.8	10.9	12.9										
M 2	0,123	0,162	0,314	0,373	0,520	0,628	4			1,90						
M 2,2	0,196	0,265	0,510	0,598	0,843	1,010	4,5*			2,64						
M 2,5	0,284	0,373	0,726	0,863	1,206	1,451	5			3,55						
M 3	0,441	0,588	1,128	1,344	1,883	2,256	5,5			4,64		14,4			2,32	
M 3,5	0,677	0,902	1,736	2,060	2,893	3,481	6*	17,6	7,4	5,92		17,6			2,96	
M 4	1,000	1,344	2,599	3,040	4,315	5,148	7	25,2	11,4	9,12		25,2			4,56	
M 5	1,916	2,648	5,099	6,031	8,483	10,200	8 9*	34,5 45,4	16,6 23	13,3 18,4		34,5 45,4	34,5 45,4	6,65 9,20		
M 6	3,432	4,511	8,728	10,300	14,710	17,652	10	58,1	31	24,8	58,1	58,1	58,1	12,4		
M 7	5,590	7,453	14,220	17,162	24,517	28,439	11 12	72,7 89,1	40,4 51,5	32,3 41,2	72,7 89,1	72,7 89,1	72,7 89,1	16,1 20,6		
M 8	8,238	10,787	21,575	25,497	35,304	42,168	13 14*	107 128	64,5 79,4	51,6 63,5	107 128	107 128	107 128	25,8 31,7		
M 10	16,67	21,575	42,168	50,014	70,608	85,317	15 16 17	150 175 201	96,2 115 134	77,0 92,3 107	150 175 201	150 175 201	150 175 201	38,5 46,1 53,5		
M 12	28,44	38,246	73,550	87,279	122,60	147,10	18 19* 20*	230 261 294	160 186 215	128 149 172	230 261 294	230 261 294	230 261 294	64,0 74,5 86,0		
M 14	45,11	60,801	116,70	138,30	194,20	235,40	21 22* 23*	330 368 408	247 281 319	198 225 255	330 368 408	330 368 408	330 368 408	99,0 112 127		
M 16	69,63	93,163	178,5	210,80	299,10	357,90	24 25* 26*	451 496 544	359 402 449	287 322 359	451 496 544	451 496 544	451 496 544	143 161 179		

	USER'S AND MAINTENANCE MANUAL	Date:	09/04/2024
		Code	MAN D90KA ENG
Motor compressor: D90KA		Revision	06

13.4 Maintenance

13.4.1 CHECKING THE FILTER AIR INTAKE

This check should be performed periodically every 100 hours of work;
If the machine operates in a very dusty environment, it will also be necessary on a daily basis.



Figure 13.4-1 Aspiration air filter

The filter consists of a filter cartridge.

For cleaning or replacement cartridge, proceed as follows:

- 1) Remove the lid by rotating it in the direction indicated by the arrow printed on it,
- 2) Remove the filter, place the new one and close the cover;



The filter cartridge must never be washed with water or other substances and never cleaned with compressed air but replaced;



It must, however, be replaced every 500 hours of work.



	USER'S AND MAINTENANCE MANUAL	Date:	09/04/2024
		Code	MAN D90KA ENG
Motor compressor: D90KA		Revision	06

13.4.2 CONTROL THE ELECTRICAL BATTERY



Extended not-use of the machine - battery charge status



- To avoid complete discharge of the battery, if the machine is not to be used for > 3 months, disconnect the negative terminal of the electrical system.
- Periodically check the battery charge and recharge it every 3 months.

Cleaning the terminals

The battery terminals (poles) must be cleaned and greased periodically. The accumulation of dirt can hinder the passage of electric current.

For cleaning it is necessary to switch off the machine, disconnect the terminals starting from the negative terminal and clean the terminals.

Checking the clamps

Generally the negative and positive pole of the battery are greased (eg. Pulp vaseline or similar product) to avoid the oxidation of metals. The paste on the clamps must be periodically replaced.

In the same way, check that the terminals are firmly connected to the battery poles and if necessary tighten them. In fact, it may happen that vibrations loosen the grip of the clamps. A mobile connection can cause malfunctions and even failures to the vehicle's electrical devices.

Checking the battery fluid (in the case of an unsealed battery)

The electrolyte must always reach the covering level of the element plates.

If the battery fluid is low, it may compromise its operation.

In these cases, if the level of covering is below the minimum level it is necessary to have it checked by a qualified electric maintenance technician and if necessary to provide the addition of cold water distilled water to restore the liquid level.

If, despite top-up, the battery continues to discharge frequently, it must be replaced.



CAUTION: Take special care when handling battery fluid. Potentially corrosive liquid.



	USER'S AND MAINTENANCE MANUAL	Date:	09/04/2024
		Code	MAN D90KA ENG
Motor compressor: D90KA		Revision	06

13.4.3 FUSO REPLACEMENT

Fuse replacement should be performed when one or both fuses were damaged or not intervene.

To replace the fuse proceed as follows:

- 1) Stop the machine;
- 2) Open the bonnet;
- 3) Open the fuse box;
- 4) Pull the fuse to be replaced with tweezers (to fuse 15 A), and unscrew the screws for the 40 A fuse:
- 5) Once removed the fuse concerned, observe the internal filament, this must be intact to function properly, if this is the case simply up item. If this filament is sectioned into two means this is to be replaced;
- 6) In the event of a damaged fuse replace it by choosing a fuse with identical characteristics. The characteristics of the fuses are described 8.3in this manual;
- 7) After inserting the new fuse in the housing close the fuse box;
- 8) Close the bonnet;
- 9) Now you can restart the machine.



13.4.4 REPLACEMENT LAMPS LIGHT (FOR VERSION APPROVED)

For the replacement of a bulb must procedures as listed below:

- 1) Stop the machine;
- 2) Open the cover of the headlight using a screwdriver to remove the four screws of the lamp
- 3) Unscrew the light bulb;
- 4) Screw in a new bulb taking into account the value of the corresponding power (see table below);
- 5) Close the cover of the headlight using a screwdriver to screw the four screws of the headlights

Headlight composition		
Type of bulb	Power bulb	Number of bulbs
Lamp position, stop *	5/21 W	1
Signal light bulb	21 W	1
License plate lamp and rear fog	21 W	1

* The lamp position/stop double stranded vary its own light intensity depending on the use of the brake



	USER'S AND MAINTENANCE MANUAL	Date:	09/04/2024
		Code	MAN D90KA ENG
Motor compressor: D90KA		Revision	06

13.4.5 TYRE PRESSURE MONITORING



Make sure that the tire is "cold", i.e., that has driven more than 2 km, so that the air inside is not already expanded.

The nominal pressure of the tire expressed in BAR is 2.5 atm

Unscrew the valve cap from the tire. The valve is a tube of black metal placed near the hubcap, about 2-3 cm long.

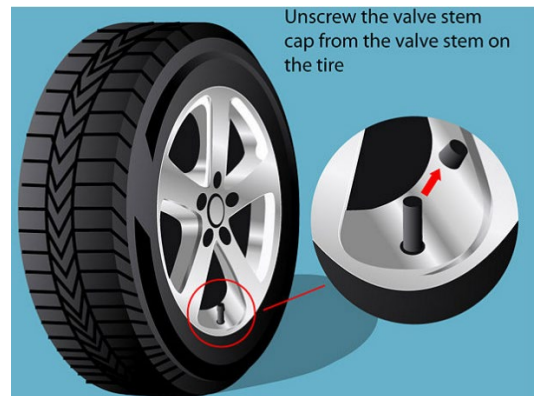

Place the gauge on the valve and read the value reported. If you hear a "breath", it means that the gauge was not properly connected and the measurement will not be reliable. You may need to reallocate the valve of the pressure gauge.

If the pressure of the tire conforms to the parameters indicated in Chapter 2 of this manual, there is nothing left to do but check the remaining tires. If the pressure is lower, you must enter the air in the tire checking the value measured by the manometer



Replace the valve cap.

The cap serves to keep clean and to protect the valve mechanism from dust and moisture.



	USER'S AND MAINTENANCE MANUAL	Date:	09/04/2024
		Code	MAN D90KA ENG
Motor compressor: D90KA		Revision	06

13.4.6 CLEAN THE RADIATOR COOLER

The coolants of the compressor and the motor are cooled by a radiator which, consequently, must be kept clean so that the ventilation air can pass freely and easily through its fins honeycomb.

A radiator fins clogged with dust or any other bodies, because of the harmful and dangerous overheating to the mechanical screw compressor, greatly jeopardizing the operation and durability. We recommend that you check it periodically and, if necessary, clean it with compressed air or clean it with a jet of water under pressure.

13.4.7 PERCENTAGE DOSAGE OF COOLING LIQUID

To determine the proper amount of antifreeze to be paid within the tank of the radiator (Figure 13.4-3) must follow the following table:

T (°F)	Total volume of the cooling plant	Water volume	Antifreeze volume	Antifreeze percentage*
(°F)	(gal)	(gal)	(gal)	%
14	1	0.80	0.20	20%
5	1	0.70	0.30	30%
- 4	1	0.60	0.40	40%

*Cooling liquid suggestions: ROLOIL ROL-ICE BLU



Figure 13.4-3 Checking the coolant radiator



WARNING: He radiator cap (Figure 10.1-3) must never be removed in a warm engine: in this condition would occur a sudden leakage, which could cause serious burns to the person. The possible filling must be done with a mixture of water and antifreeze liquid, in the percentage indicated on the container of the latter.



	USER'S AND MAINTENANCE MANUAL	Date:	09/04/2024
		Code	MAN D90KA ENG
Motor compressor: D90KA		Revision	06

13.4.8 CHECKING AND CLEANING NOZZLE OIL RECOVERY

Control and clean the oil recovery is to be performed, should you find a leak of oil mist mixed with air compressed, operating as follows (Figure 13.4-4).

- 1) Unscrew the fitting located at the center of the tank (Letter Z in Figure 13.4-4);
- 2) Inside the ring (Letter Z in Figure 13.4-4) is a nozzle (Letter U in Figure 13.4-4): make sure that its calibrated hole is not blocked (blow with compressed air);
- 3) Replace the fitting.



WARNING: During normal operation of the compressor, in the pipe from the fitting transparent part (Z), you will notice a certain amount of oil flow from the said fitting (Z) towards the head of the compressor

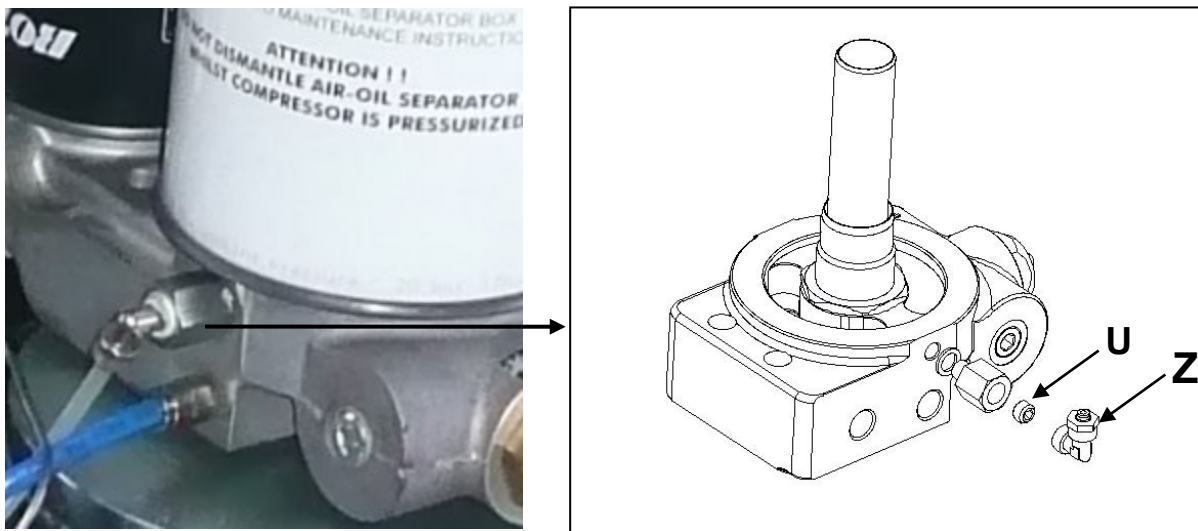

Figure 13.4-4 Nozzle oil recovery

13.4.9 DRAINAGE OF THE FUEL TANK

The draining of the fuel tank has the aim to eliminate the water possibly settled on the bottom of the tank due to the formation of condensation or refilling fuel polluted.

Avoid fuel filling with cans because sometimes, these may contain traces of water which, being heavier than the gas oil, is deposited on the bottom and can build up to reach the level of the dip tube.



Periodically carry out the drains to prevent even small parts of water can be aspirated and injected into the engine.

It is also advisable to carry refuel at the end of the work shift to prevent the temperature range of the tank walls make possible the formation of condensation inside it.

In conjunction with the drainage of the tank, also proceed to the replacement of the fuel filter to eliminate from the fuel every trace of water.



The draining of the tank must be performed at least 30 minutes after stopping the machine, to allow water to separate from the diesel fuel and to settle to the bottom of the tank.



	USER'S AND MAINTENANCE MANUAL	Date:	09/04/2024
		Code	MAN D90KA ENG
Motor compressor: D90KA		Revision	06

The polluted fuel spilled from the purges should be collected and delivered to specialized centres and authorized the collection and disposal of hazardous waste.



Remember that the residual fuel should not be totally discarded in the environment.

13.4.10 REPLACING DIESEL PRE-FILTER

To replace the pre-fuel filter (Figure 13.4-5) proceed as follows:

1. Turn off the machine;
2. Open the bonnet;
3. Bring small pan to contain any spillage of small amounts of oil still in the pipeline;
4. Pull out the pre-fuel filter to be replaced;
5. Oil the seal of the new filter to be tightened and only by hand;
6. Check the tightness;
7. Close the bonnet;
8. Turn on the machine.



Figure 13.4-5 Pre-diesel filter

13.4.11 CHECK BREAK DEVICE



For this and for the replacement of the brake drum see the user's manual of the group-axle brake-repulsion, prepared by the manufacturer, attached to the documentation provided with the machine.



	USER'S AND MAINTENANCE MANUAL	Date:	09/04/2024
		Code	MAN D90KA ENG
Motor compressor: D90KA		Revision	06

13.4.12 CONTROL OF LOCKING WHEEL BOLTS

Periodically check the tightness of the wheel bolts using a spanner, avoiding the use of air screwdrivers that may damage the bolt threads.

13.4.13 OIL FILTER REPLACEMENT COMPRESSOR

For proper filter replacement compressor oil must do the following:

- 1) Stop the machine and open the hood of the engine compartment;
- 2) Use a chain wrench to unscrew the filter to be replaced (Figure 13.4-6);
- 3) Oil the seal of the new filter to be tightened and only by hand;
- 4) Start the machine and make sure that there are no oil leaks in the vicinity of the seal, in this case to stop the machine and recheck the status and the correct positioning of the seal in its housing.



Figure 13.4-6 Compressor oil filter



WARNING: The filter is impregnated exhausted mineral oil pollution and harmful to the environment, therefore it must be disposed of at specialized centres of collection and treatment of waste.



WARNING: Replace the compressor oil filter after 500 hours or after a long storage period (9-12 months) whichever comes first before.



	USER'S AND MAINTENANCE MANUAL	Date:	09/04/2024
		Code	MAN D90KA ENG
Motor compressor: D90KA		Revision	06

13.4.14 REPLACEMENT OF COMPRESSOR OIL

The oil compressor must be performed taking into consideration the working conditions in which the machine operates (dusty, very high temperatures, etc.).

The oil change intervals must never exceed 1,500 hours of work.

In conjunction with the replacement of the oil must be changed, the corresponding filter (Paragraph 13.4.13).

RECOMMENDED OIL	QUANTITY	PART NUMBER
AIRLUBE PORTABLE LUBRICANT	2.5 Gallons	512-12-0000
	5 Gallons	512-12-0001
	55 Gallons	512-12-0002
	330 Gallons	512-12-0003



WARNING: It is strictly recommended to use ONLY OIL FOR SCREW COMPRESSORS. ELGI declines any responsibility if other oils will be used.



13.4.15 CHECKING THE OIL MIST SEPARATOR

Filter life oiler is expected around 2000 hours of work, but is closely related to a careful observance of all maintenance requirements given in this manual.

A quantity of oil or excessively low in the tank, the breach of the frequency of oil changes or the use of the machine with cooling radiator clogged may determine an anticipated and irreparable deterioration of the filters. Therefore, if, after the control and clean the recovery (operation described in the paragraph 13.4.8) and making sure the proper oil level in the tank, you are still traces of oil in the compressed air, is will have to replace the exhaust cleaner.

To ascertain the degree of clogging of the filter separator operate as follows:

- 1) Install a pressure gauge upstream of the separator and make sure that on the machine is efficient.
- 2) Start the machine.
- 3) Partially open the faucet flow until the pressure gauge on the control panel shows the value of the operating pressure.
- 4) Read the value of the pressure gauge located upstream of the oil separator filter and compare two values: if, between the two readings, is a difference of more than 1 bar replace the filter separator

The oil separator filter must never be washed with water.



WARNING: *Pressure vessel*



	USER'S AND MAINTENANCE MANUAL	Date:	09/04/2024
		Code	MAN D90KA ENG
Motor compressor: D90KA		Revision	06

13.4.16 REPLACEMENT OF THE OIL SEPARATOR FILTER

To replace the oil separator filter proceed as follows:

- 1) The operation must be performed with the machine stopped and in the absence of pressure in the oil separator tank.
- 2) We recommend applying a cloth in order to contain any oil leakage that may occur during the replacement of the oil filter.
- 3) Unscrew the oil separator filter: the filter is situated above the oil separator tank
- 4) Replace the new filter making sure to lubricate the gasket.
- 5) The filter must be tightened by hand only.



Figure 13.4-7 Oil separator filter



WARNING: *Pressure vessel*

13.4.17 ENGINE CONTROL AND MAINTENANCE



As for the controls of the engine and replacing diesel filter, timing belt, motor oil, and other specific controls refer to the owner's manual of the engine manufacturer attached to this documentation.



	USER'S AND MAINTENANCE MANUAL	Date:	09/04/2024
		Code	MAN D90KA ENG
Motor compressor: D90KA		Revision	06

13.4.18 CONTROL, TENSION AND REPLACEMENT OF TRANSMISSION BELTS

For the normal and good operation of the compressor, drive belts must always be perfectly tensioned. To determine the exact tension transmission belt you need to follow these instructions (Fig. 13.4.8) Applying a force "F" between 16.50 lb and 17.50 lb in the midpoint of the free section "T" of a belt of the arrow "f" must be of c.a. 1 cm If the value of the arrow "f" should be greater than the value indicated means that the straps are loose while if the value is less means that the straps are too tight. During the control of the belts is good to check the wear of the same and if necessary to provide replacing them (Fig. 13.4-9).



WARNING: Caution: The straps too loose can cause them slip with loss of compressor power. The straps too tight deteriorate with the consequent rupture of the same.

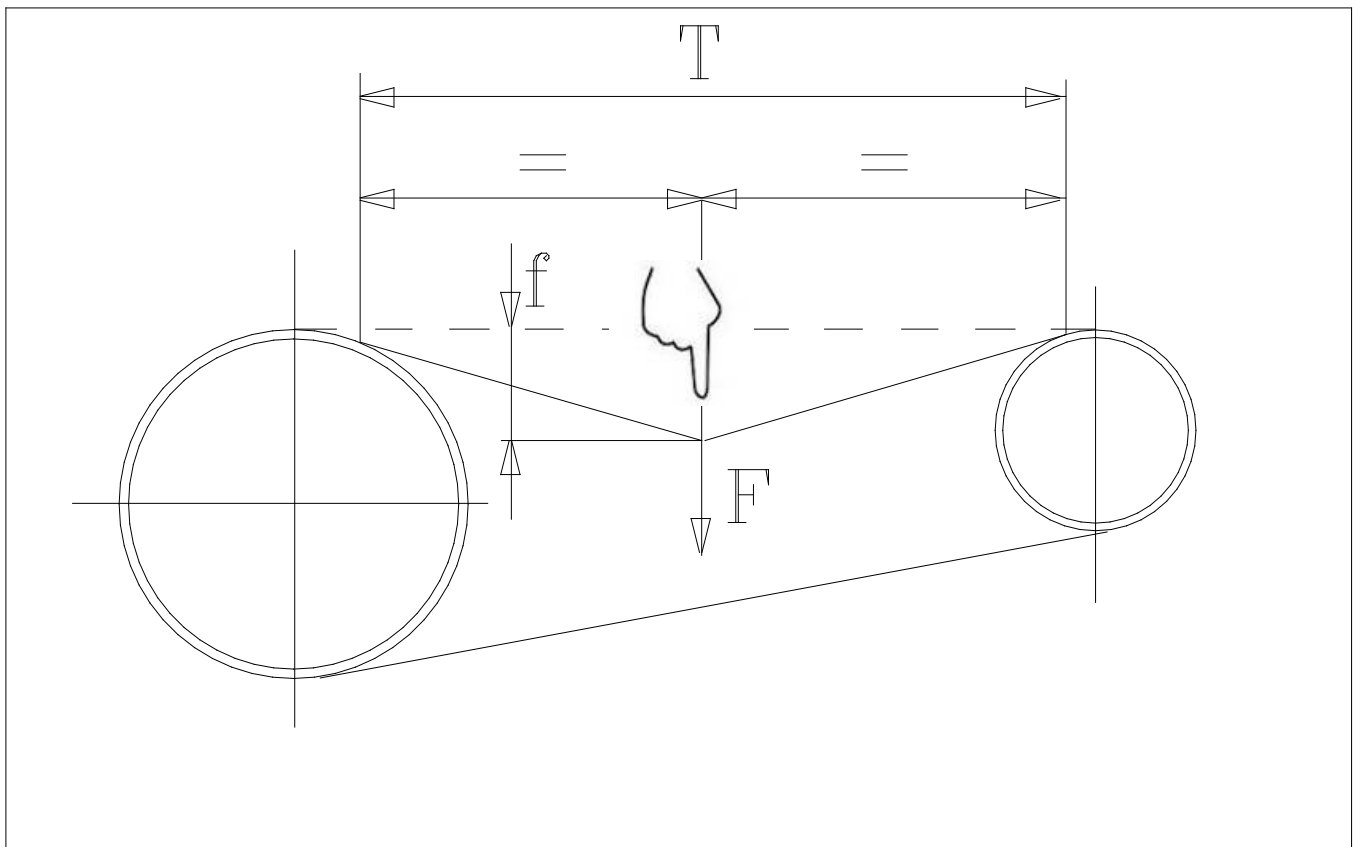

Figure 13.4-8 Tensioning straps



D90 K

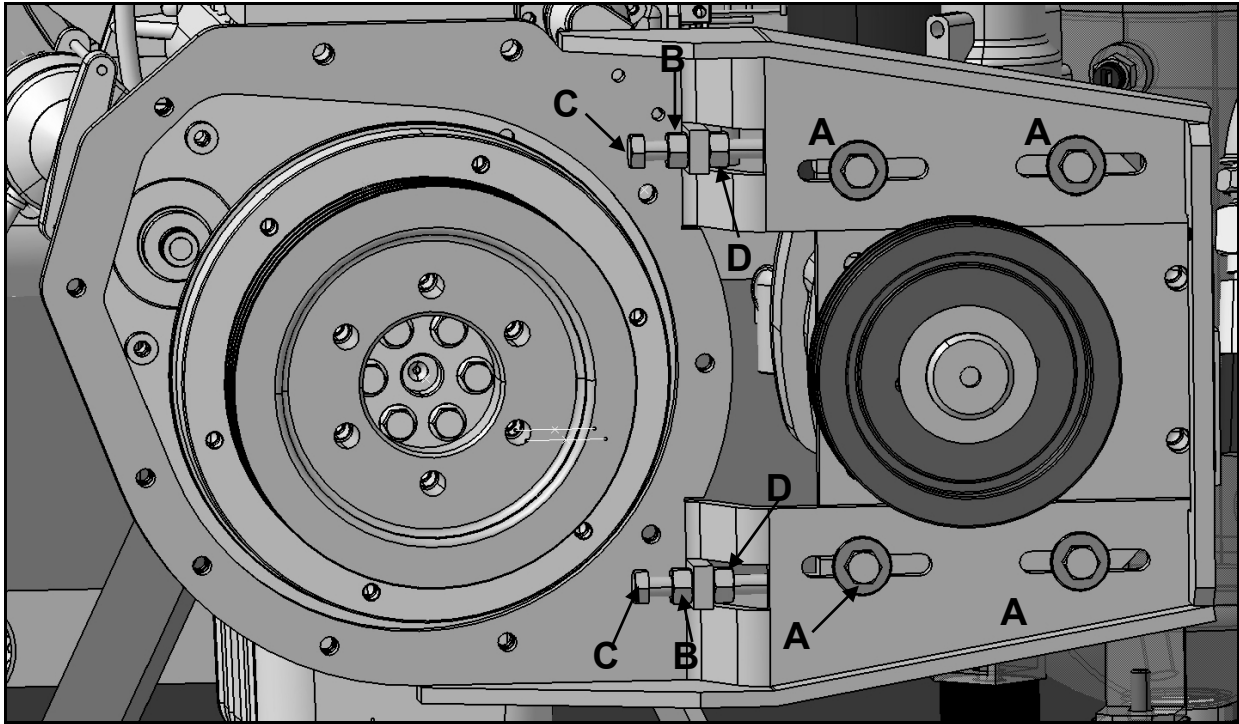

Figure 13.4-9 Disassembly straps D90 K

- Loosen the 4 bolts A
- Loosen the lock nut and locknut B & D
- Acting on the bolt for tensioning C. Tightening of the belt tension is increased and unscrewing it decreases.
- When you have reached the right tension tighten the lock nut B and D
- Close firmly the 4 screws A

14 SPARE PARTS



In case of need to order a single component contact your authorized service center ELGI.



	USER'S AND MAINTENANCE MANUAL	Date:	09/04/2024
		Code	MAN D90KA ENG
Motor compressor: D90KA		Revision	06

15 FAULTS AND TROUBLESHOOTING

Abnormal	Cause	Solution
The engine will not start.	Battery discharged or defective.	Recharge and replace if necessary.
	Terminals of the battery cables oxidized or loose.	Cleaning of the same and their tightening.
	No fuel.	Top up the fuel in the diesel tank.
	Solenoid faulty fuel.	Seek customer service by the manufacturer of the engine.
	Air in the fuel pipe.	Locate the infiltration by careful verification of all pipes.
	Injection pump defective.	Call in Customer Service by the engine manufacturer.
	Temperature sensors defective.	<p>They are located at:</p> <ul style="list-style-type: none"> - Headed-cylinder engine; - Output air compressor; - Tank separator. <p>One at a time, unplug its power cable from the probes to identify the defective sensor and replace it. The temperature light on the control panel should go off.</p>
Opening the taps the motor does not accelerate.	Starter defective Injectors failures	Call in Customer Service by the engine manufacturer.
Opening the taps the motor does not accelerate.	Control valve of maximum pressure defective.	Remove the control valve max and accurately control the spring and the conical seat. If the defect cannot be repaired, the valve must be replaced.
The engine speeds up but no air come out	Minimum pressure control valve blocked.	<p>Disassemble and check that the piston is free to move. Check that the spring is intact. If the defect cannot be repaired the valve must be replaced.</p> <p>Reassemble and adjust the minimum pressure following the instructions in Section 11.3.</p>
The machine stops suddenly and can only be restarted after a few minutes of	A temperature sensor detects a temperature anomaly and consequently stops the machine.	<p>Take off one at a time, locate the probe that determines the stop. If that proves to be placed on the engine, check the oil level of the motor, the voltage and the conditions of the alternator belt.</p> <p>For water-cooled engines, check the coolant level.</p>



	USER'S AND MAINTENANCE MANUAL	Date:	09/04/2024
		Code	MAN D90KA ENG
Motor compressor: D90KA		Revision	06

Abnormal	Cause	Solution
waiting.		<p>If it turned out to be the probe placed on the compressor control the level of 'oil in the tank and if necessary top up;</p> <p>Check the cooling fan and clean the radiator; replace the oil filter of the compressor.</p> <p>If that proves to be positioned on the oil separator tank, check the oil separator filter following the instructions to Par. 13.4-15, proceeding to its eventual replacement Par 13.4-16.</p>
Abnormal	Cause	Solution
The engine does not reach the maximum speed of the speed indicated and the compressor does not do.	The spring piston accelerator is broken or to be put under tension.	Check the tension of the spring piston accelerator (Par. 11.1.2).
	Engine speed lower than expected.	<p>Have the injection apparatus of the motor by qualified personnel.</p> <p>Replace the fuel filter. Run the draining of the fuel tank (Par. 13.4.9).</p>
Oil leaking from the taps.	Minimum working pressure too low.	Adjust it according to the instructions of Par. 11.3.
	Too much oil in the tank.	To the correct level (Par.13.4).
	The machine works in non-horizontal position.	Ensure position the machine level
	Nozzle clogged oil recovery.	See Par. 13.4.8.
	Defective exhaust cleaner.	See Par. 13.4.15.

	USER'S AND MAINTENANCE MANUAL	Date:	09/04/2024
		Code	MAN D90KA ENG
Motor compressor: D90KA		Revision	06

16 DISPOSAL, ELIMINATION, DISPOSAL OF THE MACHINE

16.1 Instructions for dismantling

To dismantle the machine safely, proceed as follows:

- 1) Place the machine in a wide and make sure it is turned off.
- 2) Empty the liquid waste in the tanks of motor oil, fuel, coolant, hydraulic oil and store them in special containers. For disposal of these types of waste follow the next paragraph.
- 3) Loosen the screws of the body and remove covers
- 4) Remove all the components of the machine one by one dividing them according to their material composition

The various components of the machine have to be disposed in relation to the type of waste to which they belong.

The following describes the different types of waste that can be generated during the life of the machine:

- Waste motor oil
- Waste hydraulic oil
- Residues of coolant
- Residual fuel
- Liquid remaining battery power
- Rags or paper impregnated with a diluents or other substances used for the cleaning of the various organs of the machine

17 ELIMINATING THE MACHINE

The operations of destruction and disposal must be carried out in a safe condition by a qualified specialist and after carefully reading and incorporated the recommendations and instructions provided in this section of the manual of use and maintenance and consulting the safety data sheets relating to substances in the machine mentioned in the previous chapter..

Once you reach the end of the mechanical life of the compressor, this has to be taken out of service so that it cannot be used for other purposes.



	USER'S AND MAINTENANCE MANUAL	Date:	09/04/2024
		Code	MAN D90KA ENG
Motor compressor: D90KA		Revision	06

18 WASTE MANAGEMENT



The withdrawal of special waste and / or hazardous should be entrusted with the written contract to authorized firms; and those who physically transport and handling must be in possession of the required authorizations. The hauliers authorized must be enrolled in the relevant register.

18.1 Special waste

They are considered a hazardous waste residue from industrial, agricultural, crafts, commercial and service, for quality or quantity, is declared similar to municipal waste. These include also: machinery, equipment and metal parts of engines deteriorated and obsolete.



18.2 Toxic and hazardous waste



Are considered hazardous toxic waste all waste containing or contaminated by the substances listed in Directives 75/442 / CEE, 76/403 / CEE and 768/319 / CEE or other regulations in the countries of use and installation of the machines.



18.3 Temporary storage



Are considered hazardous toxic waste all waste containing or contaminated by substances listed in Directives 75/442 / CEE, 76/403 / CEE and 768/319 / CEE or other regulations in the countries of use and installation of the machines.

Temporary storage of toxic and hazardous waste is allowed according to the expected disposal of waste by treatment and / or final disposal. In any case, observe the mandatory laws of the country of the user in the field of environmental protection.

18.4 Features of the containers

The fixed and mobile containers, designed to contain toxic and hazardous waste must possess adequate strength requirements in relation to the chemical-physical properties and to its hazardous characteristics of the waste contained. The containers in which products are stored or dangerous or harmful materials must, in order to disclose the nature of their content, carry signs and markings prescribed.



18.5 Registration requirements

In accordance with the EU Directive 75/439 / CEE on the disposal of waste oil, the records of loading / unloading must be kept by all companies that produce hazardous waste or hazardous toxic from industrial and artisanal (in each case the 'Users should refer to the regulations implementing that Directive in the country of installation and use of the machines).



PARTS LIST

D 90KA

Version:

- **STANDARD**
- **SKID**



Via Bernezzo 67 – 12023 CARAGLIO (CN) –ITALIA

TEL: +39 0171 619676 – FAX: +39 0171 619677

E-MAIL: info@rotairspa.com WEB: <http://www.rotairspa.com>

Copyright © 2014, ROTAIR S.P.A. - All rights reserved This manual is intellectual property of ROTAIR S.P.A. Its full or partial reproduction is forbidden under any form, on any support and by any means, without the written authorization by ROTAIR S.P.A.



D90 KA - Dimensions - Code A

Tab. 01.0

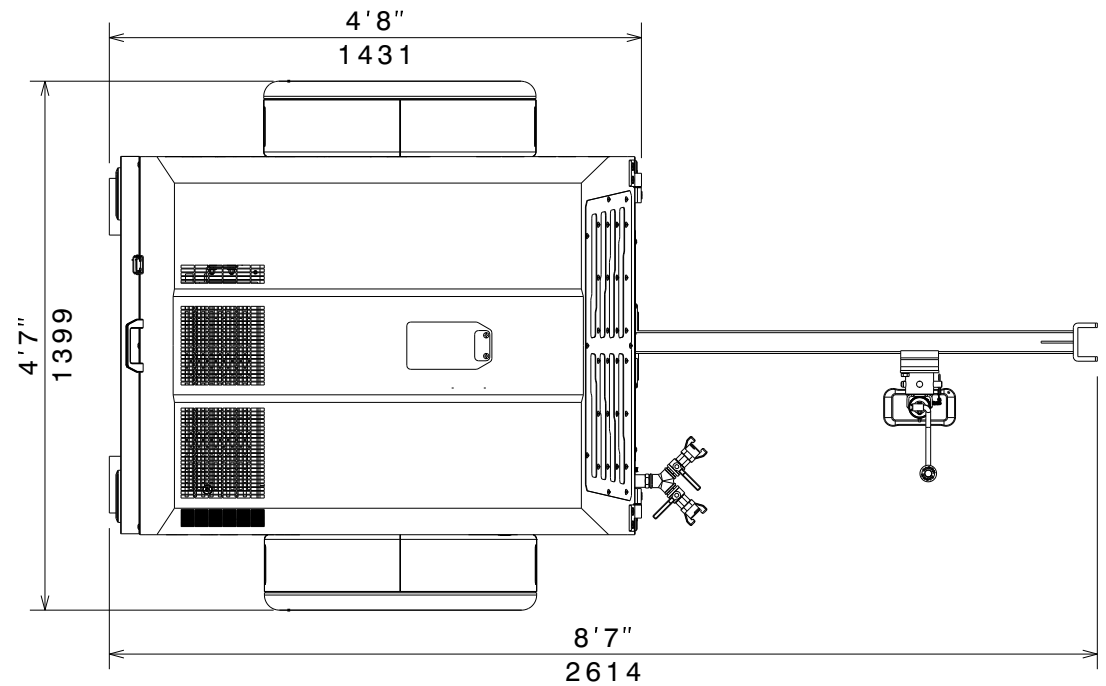
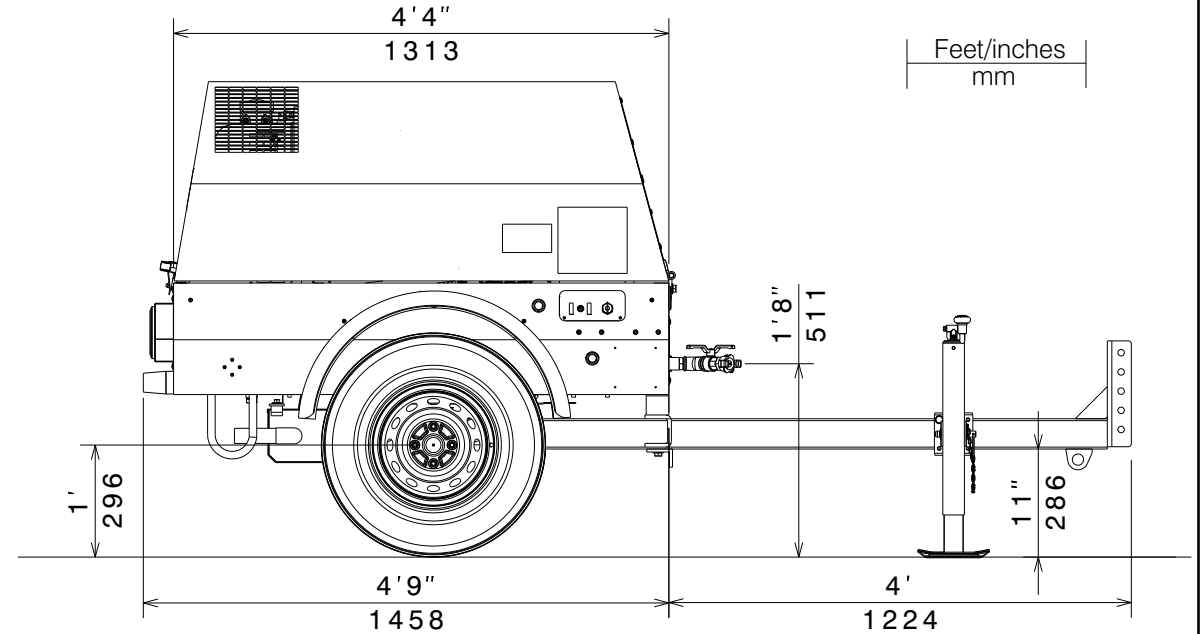
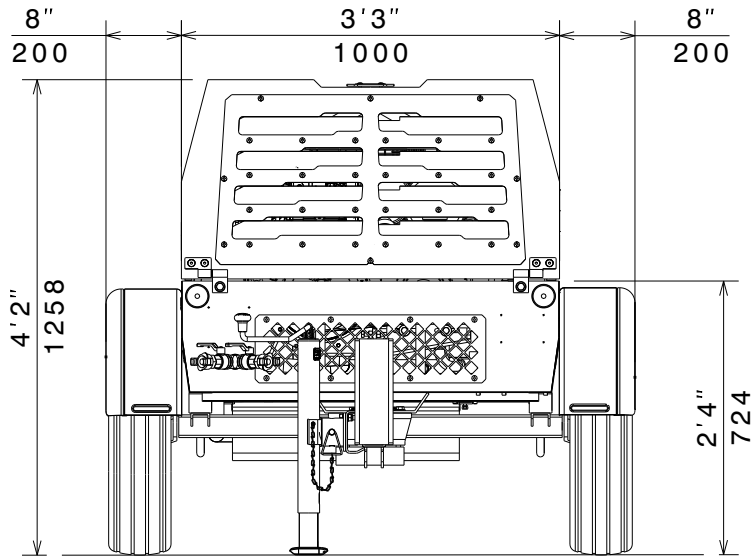



D90 KA - Dimensions - Code B

Tab. 01.0.1

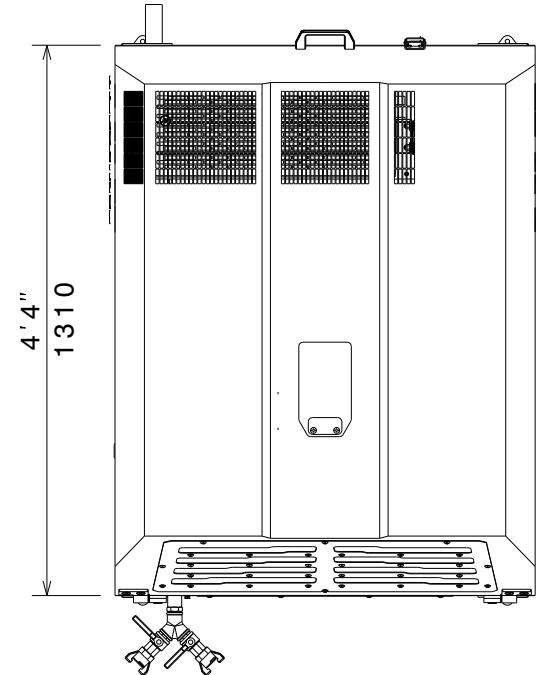
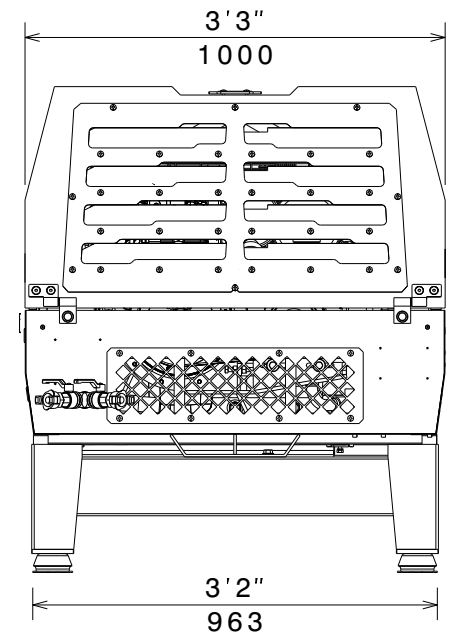
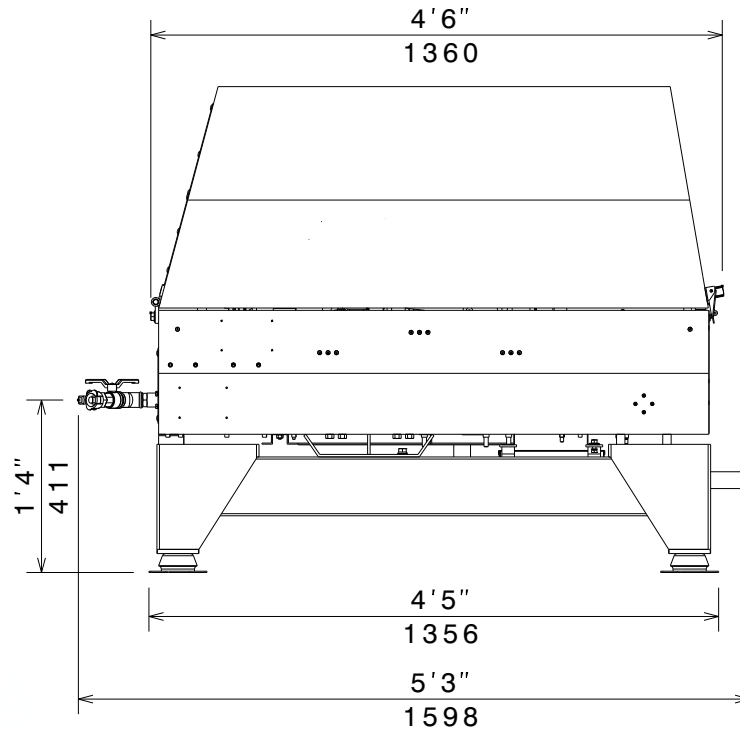
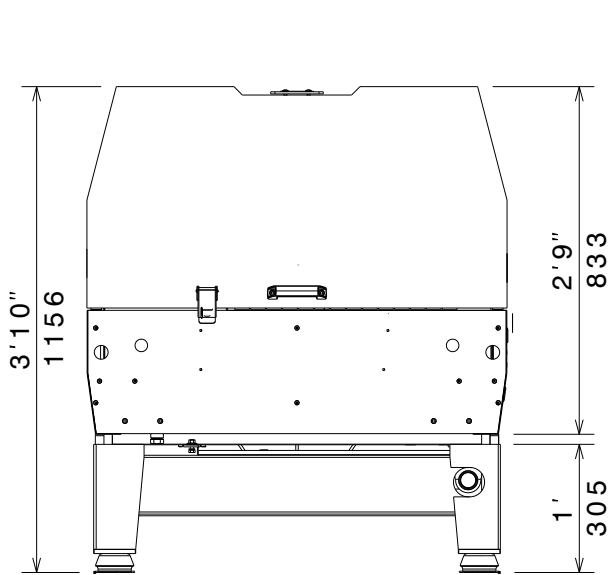

Dimensions:

Feet/inches
mm

This page has been intentionally left blank



PARTS LIST

Motocompressor – D90KA

PARTS LEGENDA: Dimensions

Tab. 01.0 / Tab.1.0.1

REF	NAME	CODE	QUANTITY
1	Standard version	A	---
2	Skid version	B	---

Detail A

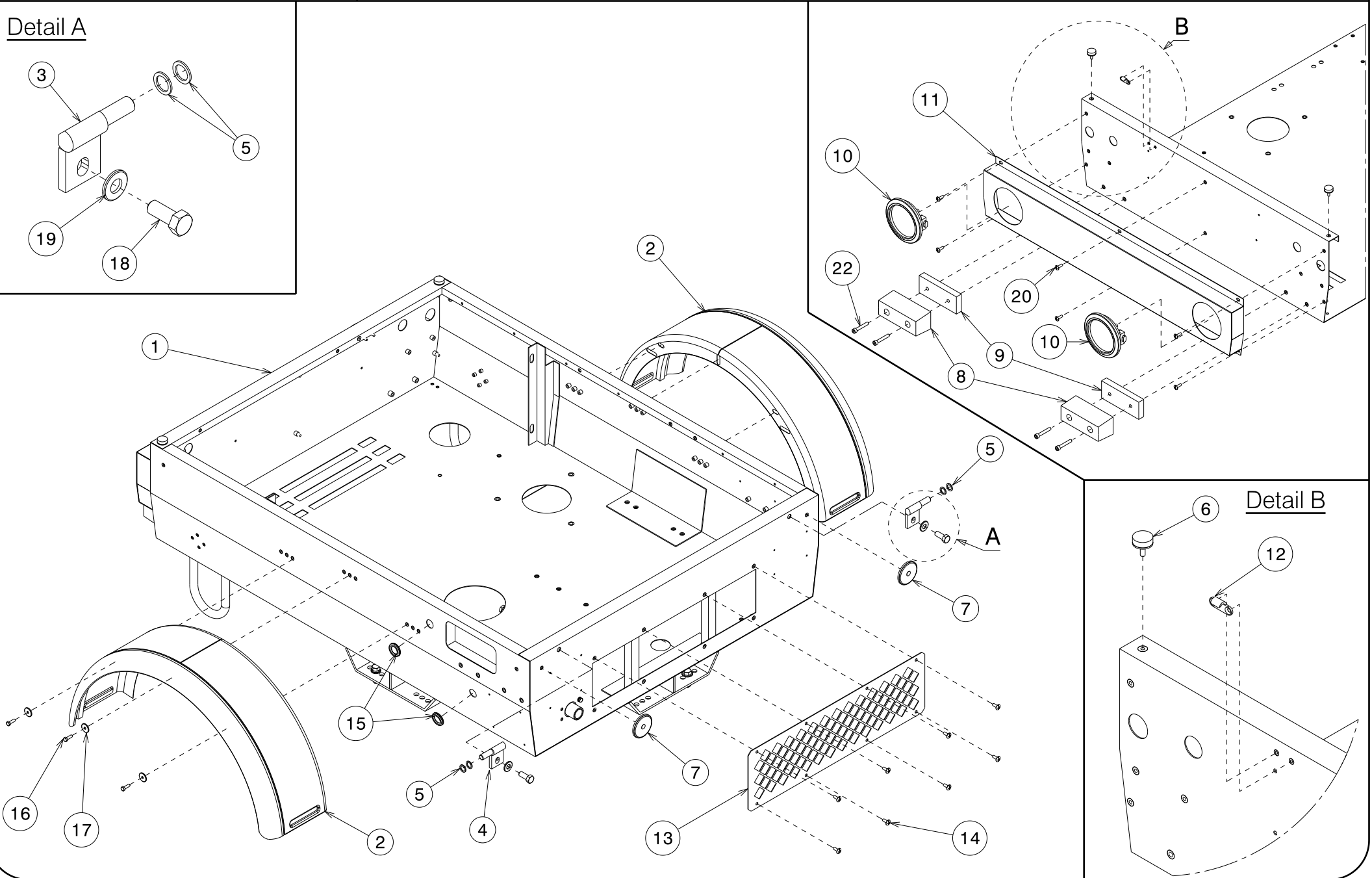
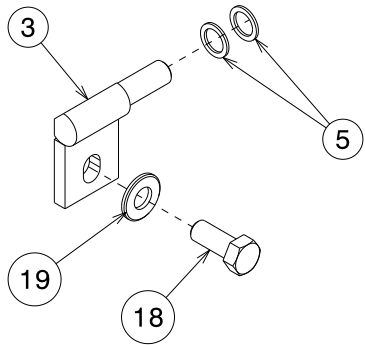

B

A

Detail B



PARTS LIST

Motocompressor – D90 KA

PARTS LEGENDA: Chassis

Tab. 01.1

REF	DESCRIPTION	CODE No.	QUANTITY
1	Chassis	038-0910-S	1
2	Mudguards	055-0154-S	2
3	Fixed left hinge	007-023-S	1
4	Fixed right hinge	007-022-S	1
5	Washer	015-008-S	4
6	Silent block	061-900-S	2
7	White reflector d.60	147-071-S	2
8	Rubber buffer	197-004-S	2
9	Bumper spacer	009-31300-S	2
10	Rear light USA	142-0050-S	2
11	Rear light support USA	010-11305-S	1
12	Lock	128-011-S	2
13	Closing panel (Tropicalized) From serial No.C38952	124-297920-S	1
14	Large head screw 6x16 Poëlier	243-009-S	8
15	Diaphragm fairlead	239-021-S	2
16	Hex head screw M6x20	132-063-S	6
17	Flat washer 6x24x2 UNI6593	015-038-S	6
18	Hex head screw M.12x30 UNI 5739	132-192-S	2
19	Flat washer d. 13	015-047-S	2
20	Large head screw 6x20 Poëlier	243-010-S	6
22	Hex socket head cap screw M.10x 16	133-138-S	4

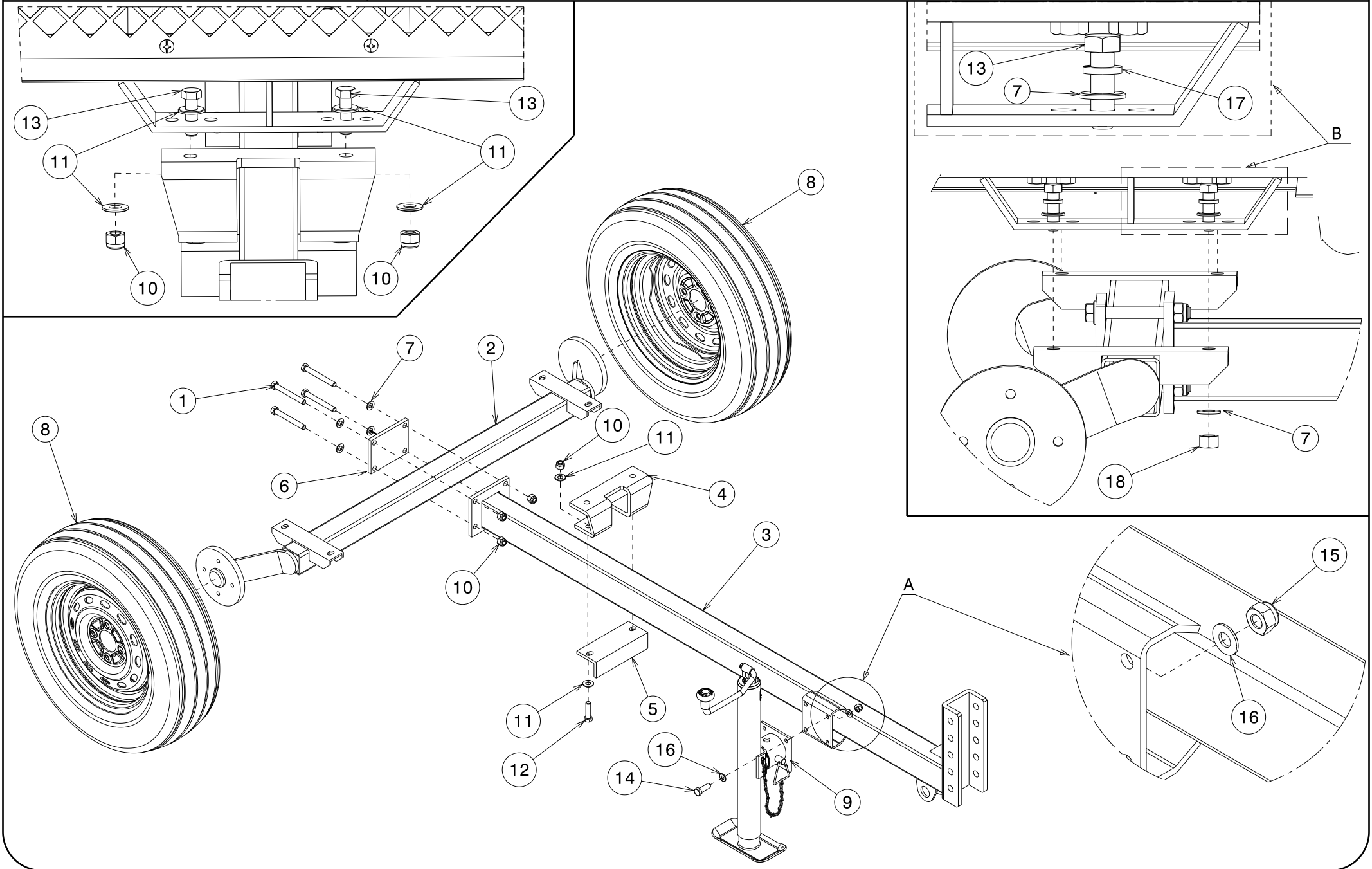



PARTS LIST

Motocompressor – D90 KA

PARTS LEGENDA: Chassis

Tab. 01.2

REF	DESCRIPTION	CODE No.	QUANTITY
1	Hex head screw M12	132-206-S	4
2	Axle	026-05400-S	1
3	Drawbar USA	046-03105-S	1
4	Upper axle clamping section	120-384500-S	1
5	Lower axle clamping section	120-39648121-S	1
6	Axle stiffening plate	208-301600-S	1
7	Plane washer diam.13	015-034-S	8
8	Tyre	054-182-S	2
9	Jackstand	068-00852-S	1
10	Self-locking nut M12	137-060-S	8
11	Flat washer d. 13	015-047-S	8
12	Hex head screw M12x45 UNI 5739	132-195-S	2
13	Hex head screw M12x40	132-194-S	6
14	Hex head screw M12x35 UNI 5739	132-193-S	4
15	Self-locking nut M10	137-050-S	4
16	Flat washer 10,2x21x2	015-032-S	8
17	Elastic washers	139-060-S	4
18	Hex nut M12 UNI 5587	135-060-S	4

Detail B

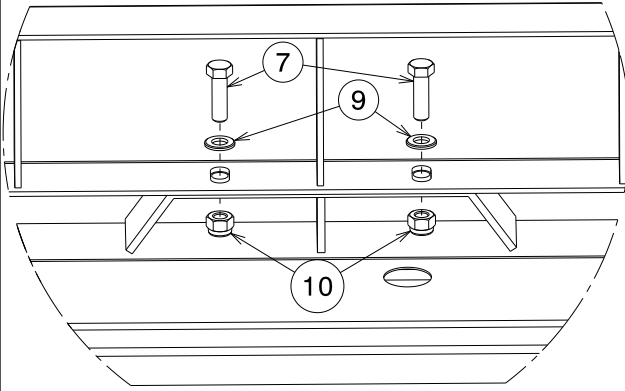

Detail C

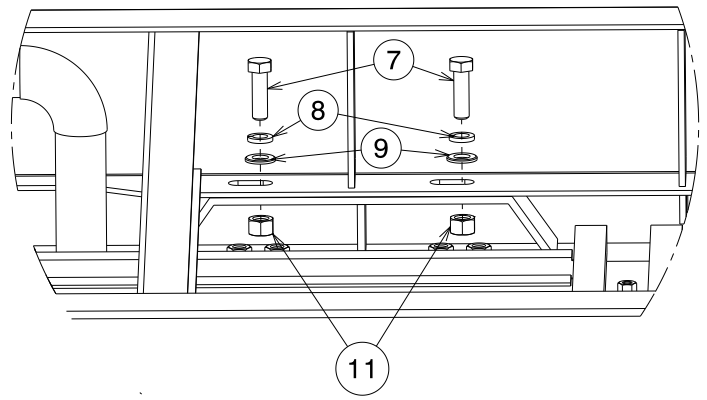

Detail A

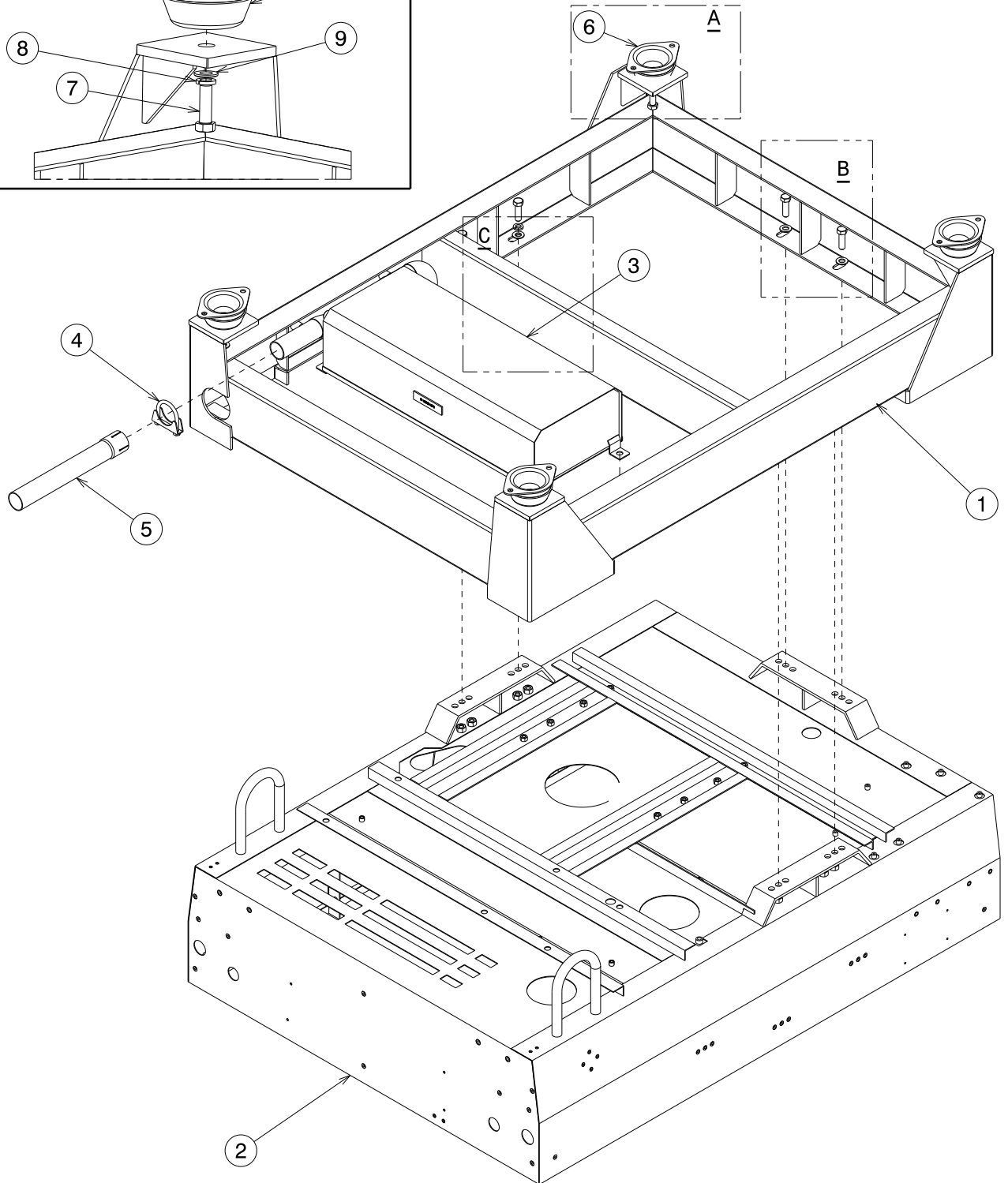
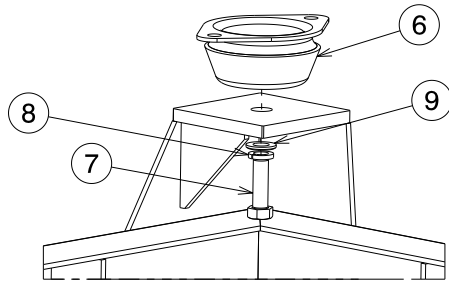



PARTS LIST

Motocompressor – D90 KA

PARTS LEGENDA: Skid Subframe

Tab. 01.3

REF	DESCRIPTION	CODE No.	QUANTITY
1	Skid subframe	038-0910020-S	1
2	Chassis	038-0910-S	1
3	Muffler	042-06660-S	1
4	Pipe clamp d.45x8	149-054-S	1
5	Muffler extension for skid version	119-04950-S	1
6	Silent Block	061-006-S	4
7	Hex head screwM12x40	132-194-S	10
8	Elastic washer	139-060-S	8
9	Flat washer d.13	015-034-S	10
10	Self-locking nut M12	137-060-S	2
11	Hex nut M12 UNI 5587	135-060-S	4

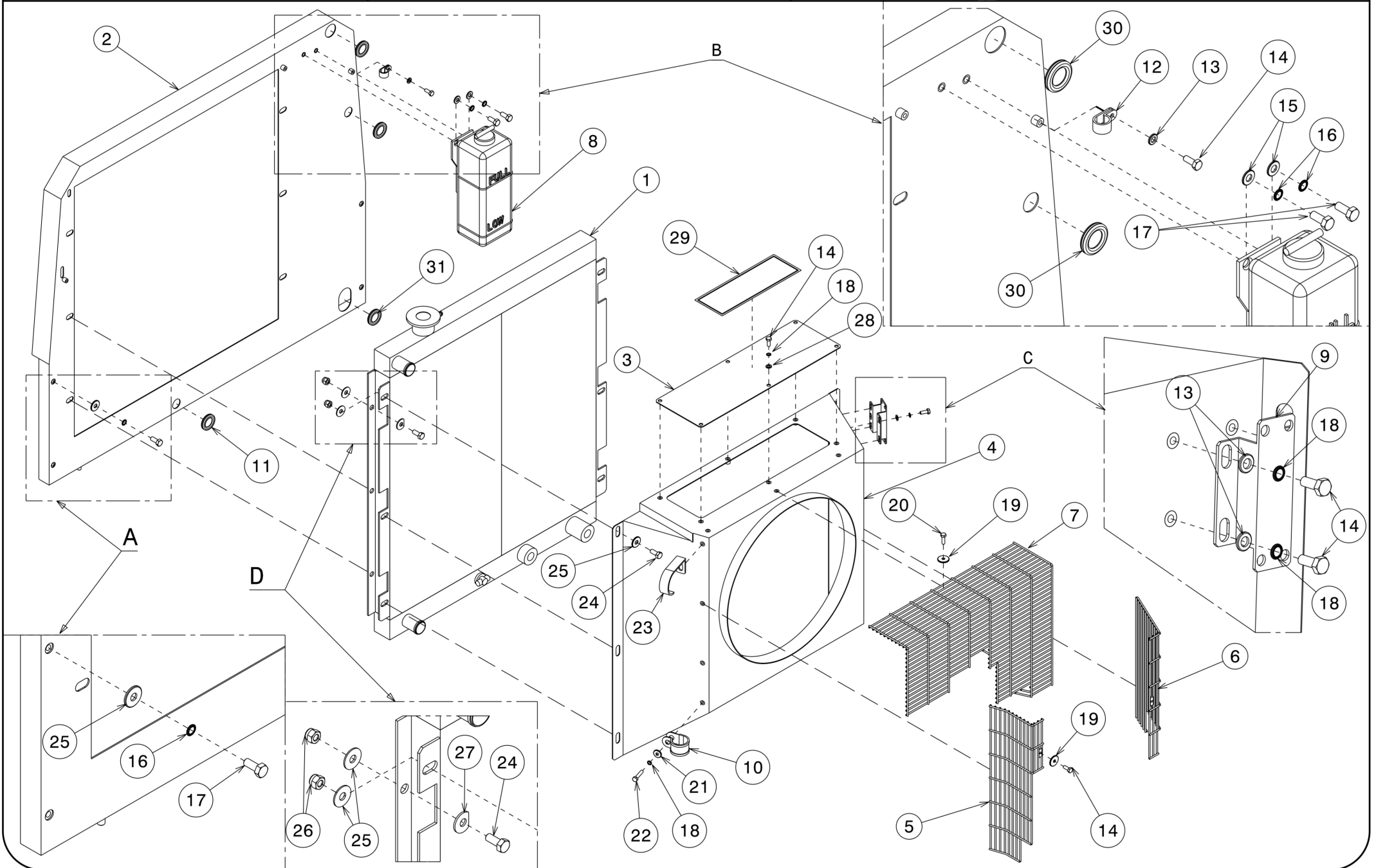



PARTS LIST

Motocompressor – D90 KA

PARTS LEGENDA: Fan cover – Radiator

Tab. 02.0

REF	NAME	CODE	QUANTITY
1	Water-oil radiator	011-09141-S	1
2	Radiator support	049-11021-S	1
3	Panel on the fan cover	124-29604-S	1
4	Fan cover	001-16061-S	1
5	Right side fan protection grid panel	124-297912-S	1
6	Left side fan protection grid panel	124-297910-S	1
7	Upper fan protection grid panel	124-297914-S	1
8	Expansion tank kit	044-098065-S	1
9	Valves group support	010-314-S	1
10	Iron clamp D1 D.35	149-237-S	1
11	Diaphragm fairlead	239-021-S	1
12	Cable fastener clamp	149-220-S	1
13	Flat washer 6,6x12x1,5 DIN125/1	015-027-S	5
14	Hexagonal head Screw M6x16 UNI 5739	132-062-S	13
15	Flat washer 8,4x17x1,5 UNI 6592	015-030-S	2
16	Schnorr washer d.8	015-251-S	6
17	Hex head screw M8x20 UNI 5739	132-101-S	6
18	Washer d.6	015-250-S	11
19	Flat washer 6x24x2 UNI6593	015-038-S	11
20	Hex head screw . M6x20	132-063-S	9
21	Washer d. 6.6x18x2	015-029-S	1
22	Hex head screw M6x30 UNI 5739	132-066-S	1
23	Aerator pipe support	214-0185-S	1
24	Hex head screw M8x20 UNI 5739	132-101-S	1
25	Flat washer 8x24x2 UNI6593	015-031-S	22
26	Self-locking M8 UNI 7473	137-040-S	12
27	Flat washer 9x24x2	015-0312-S	6
28	Flat washer 6,6x12x1,5 DIN125/1	015-027-S	6
29	Anti-freeze level control sticker	238-007-S	1
30	Diaphragm fairlead	239-016-S	2
31	Diaphragm fairlead	239-036-S	1

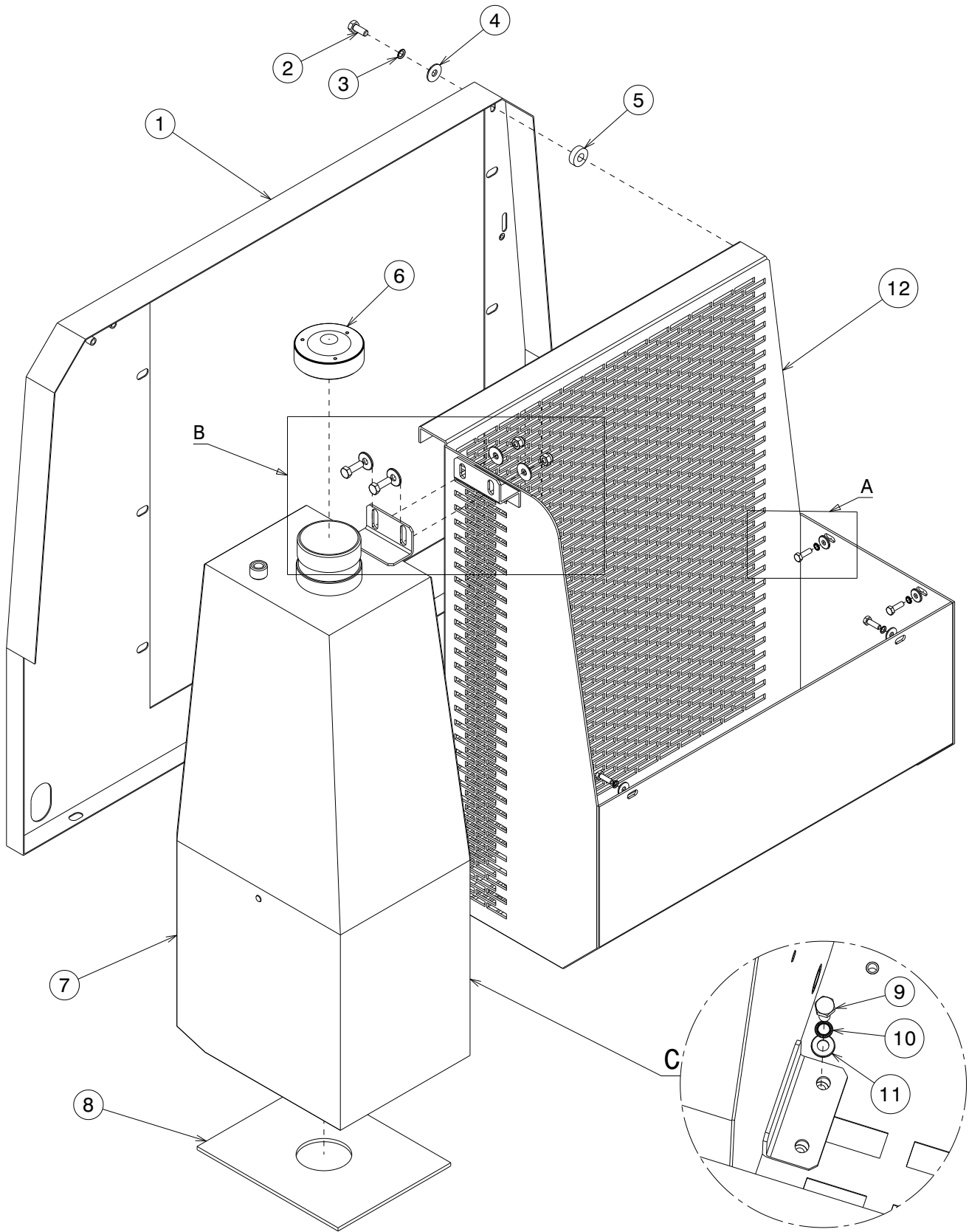

Detail B

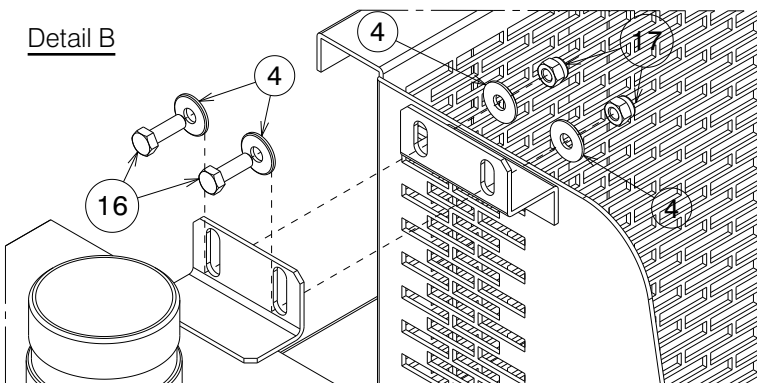

Detail A

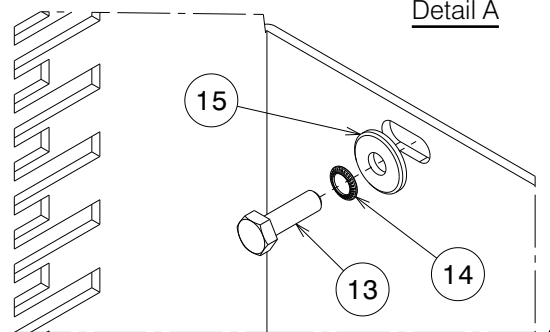



PARTS LIST

Motocompressor – D90 KA

PARTS LEGENDA: Toolbox

Tab. 02.1

REF	NAME	CODE	QUANTITY	
1	Radiator support	049-11021-S	1	
2	Hex head screw M8x20 UNI 5739	132-101-S	1	
3	Schnorr washer d.8	015-251-S	1	
4	Flat washer 8x24x2 UNI6593	015-031-S	5	
5	Spacer	009-087.5-S	1	
6	Fuel tank plug	193-016-S	1	
7	Fuel tank	201-04010-S	1	
8	Fuel tank rubber plate	177-185-S	1	
9	Hex head screw . M6x20	132-063-S	2	
10	Schnorr washer d.8	015-251-S	2	
11	Flat washer 8,4x17x1,5 UNI 6592	015-030-S	2	
12	Toolbox	From serial no. C43691	029-049201-S	1
13	Hex head screw M6x20	132-063-S	4	
14	Washer d.6	015-250-S	4	
15	Washer d. 6.6x18x2	015-029-S	4	
16	Hex head screw M8x25 UNI 5739	132-102-S	2	

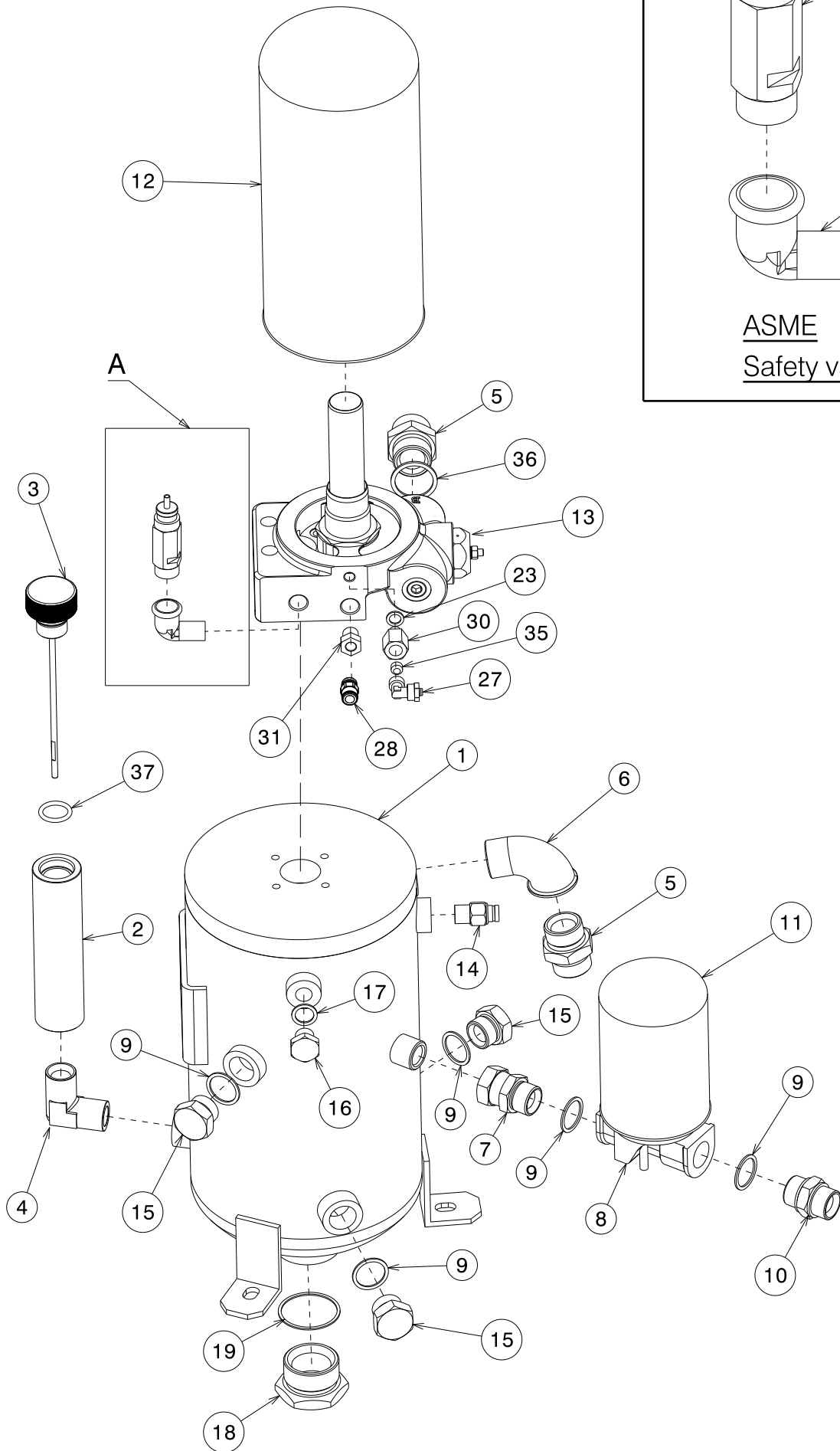



PARTS LIST

Motocompressor – D90 KA

PARTS LEGENDA: Separator tank

Tab. 03

REF	NAME	CODE	QUANTITY
1	Separator tank (2.7 gal – 10 lt)	037-00101-S	1
2	Oil sleeve	063-1205-S	1
3	Oil level rod plug	106-01060-S	1
4	Conical 90° M+M adapter coupling (3/4")	148-287.35-S	1
5	Double screw 1" at 1 1/4"	187-070-S	2
6	Short radius curve M 3/4 + F 1	111-045-S	1
7	Straight adapter coupling M+f gir. 3/4	148-005-S	1
8	Oil compressor filter support	010-0475-S	1
9	Copper waher D.Int.26,5x32x1,5 (3/4)	015-015-S	5
10	Double screw 3/4	187-060-S	1
11	Compressor oil filter	099-007-S	1
12	Separator filter	157-170-S	1
13	Valve assembly	024-021534-F	1
14	Compressor thermal contact 115°	103-008-S	1
15	Male hexagonal head iron plug (3/4")	106-130-S	3
16	Male hexagonal head iron plug (M16x1.5)	106-100-S	1
17	Copper kasher D.Int.16x22x1,5	015-009-S	1
18	Male hexagonal head iron plug (1 1/2")	106-137-S	1
19	Copper washer d. 48,4x53,4x1,3 (1 1/2)	015-019.1-S	1
20	Safety valve (ASME)	033-059-S	1
23	Copper washer (1/8")	015-005-S	1
27	Quick coupling 90° (1/4") per tubo d.8	148-573-S	1
30	Extension F+M L=30 (1/4" – 1/8")	189-302-S	1
31	Reduction M with + F cil	190-020-S	1
35	S.T screw with hexagon (1/8")	218-001-S	1
36	Copper washer	015-018-S	1
37	Or seal 4087 viton	023-026.5-S	1
41	Short radius curve M 3/8 + F 1/2	111-026-S	1

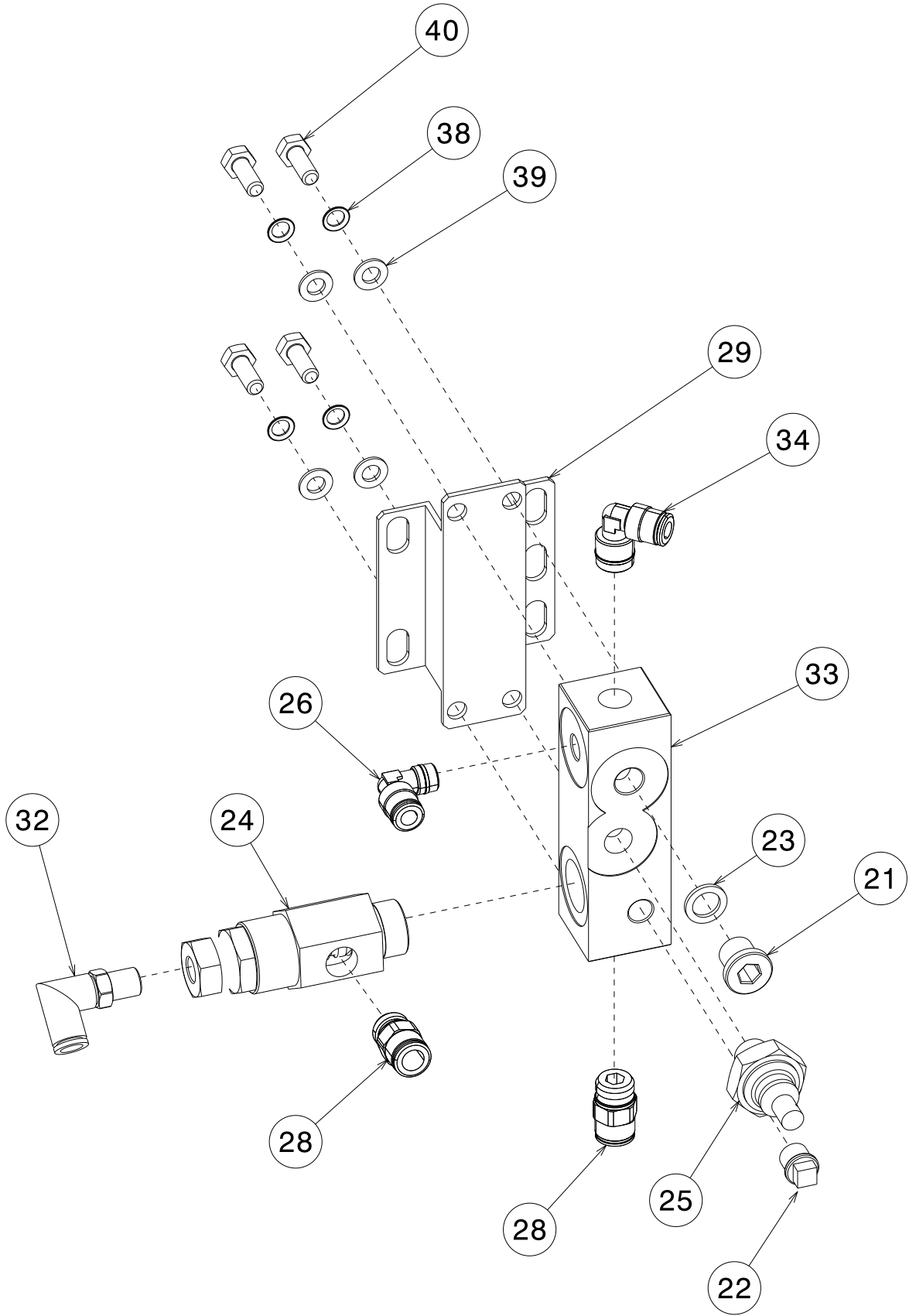

Motocompressor – D90 KA**PARTS LEGENDA:** Devices coupling block

Tab. 03.1

REF	NAME	CODE	QUANTITY
21	Hexagonal head plug (M12x1.5)	106-092-S	1
22	Square head plug (1/8")	106-020-S	1
23	Copper washer (1/8")	015-005-S	1
24	Pressure regulation valve assembly	024-0323-F	1
25	Oil pressure switch 1,4bar	154-0301-S	1
26	90° quick coupling (1/8") for pipe d.6	148-570-S	1
28	Straight quick coupling (1/4") per tubo d.8	148-575-S	2
29	Valves group support	010-314-S	1
32	Rotating quick coupling 90° M (1/8")	148-8001-S	1
33	Devices coupling block	053-300-S	1
34	Quick coupling 90° (1/4") per tubo d.8	148-573.5-S	1
38	Washer d.6	015-250-S	4
39	Flat washer 6,6x12x1,5 DIN125/1	015-027-S	4
40	Hexagonal head Screw M6x16 UNI 5739	132-062-S	4

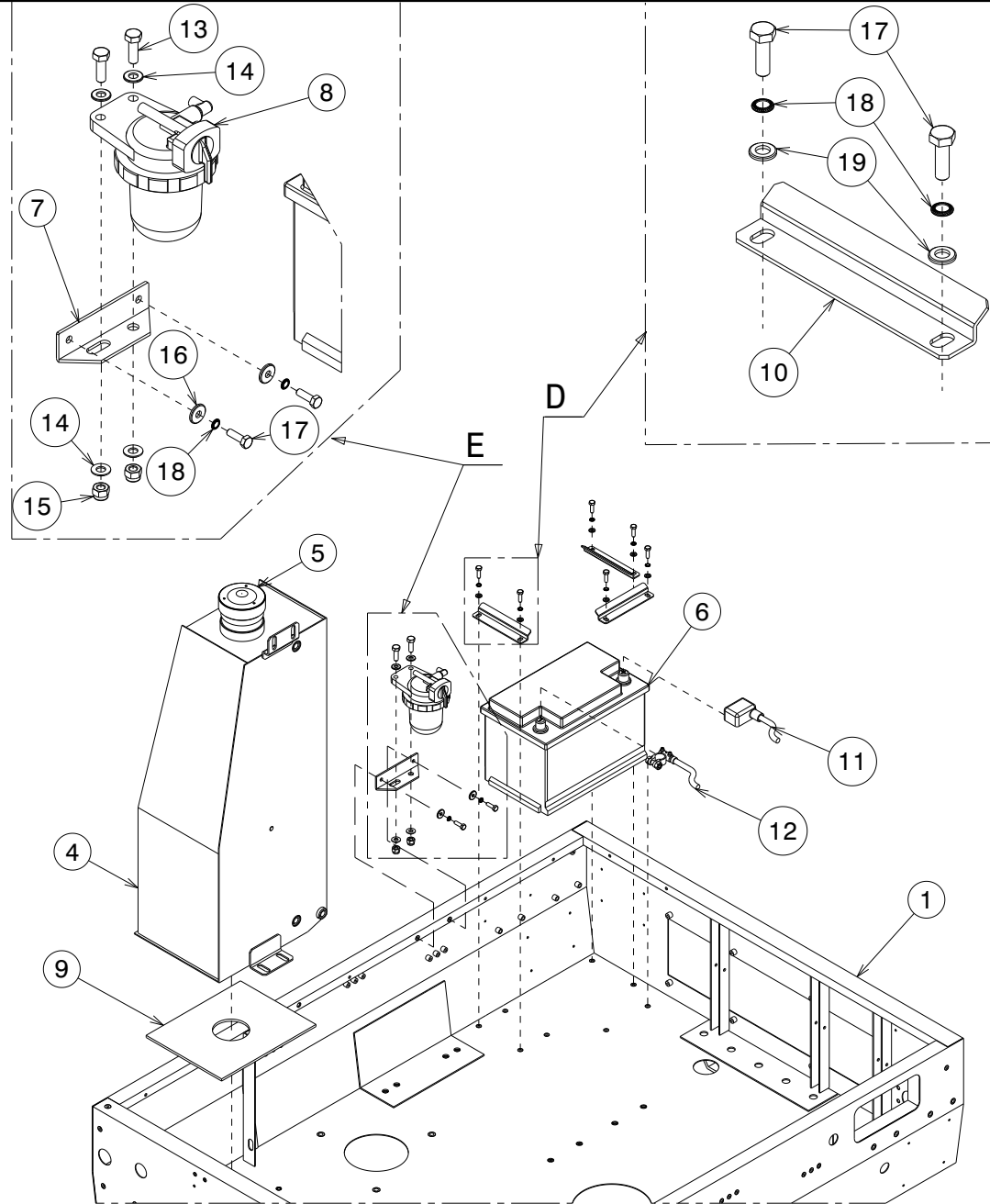
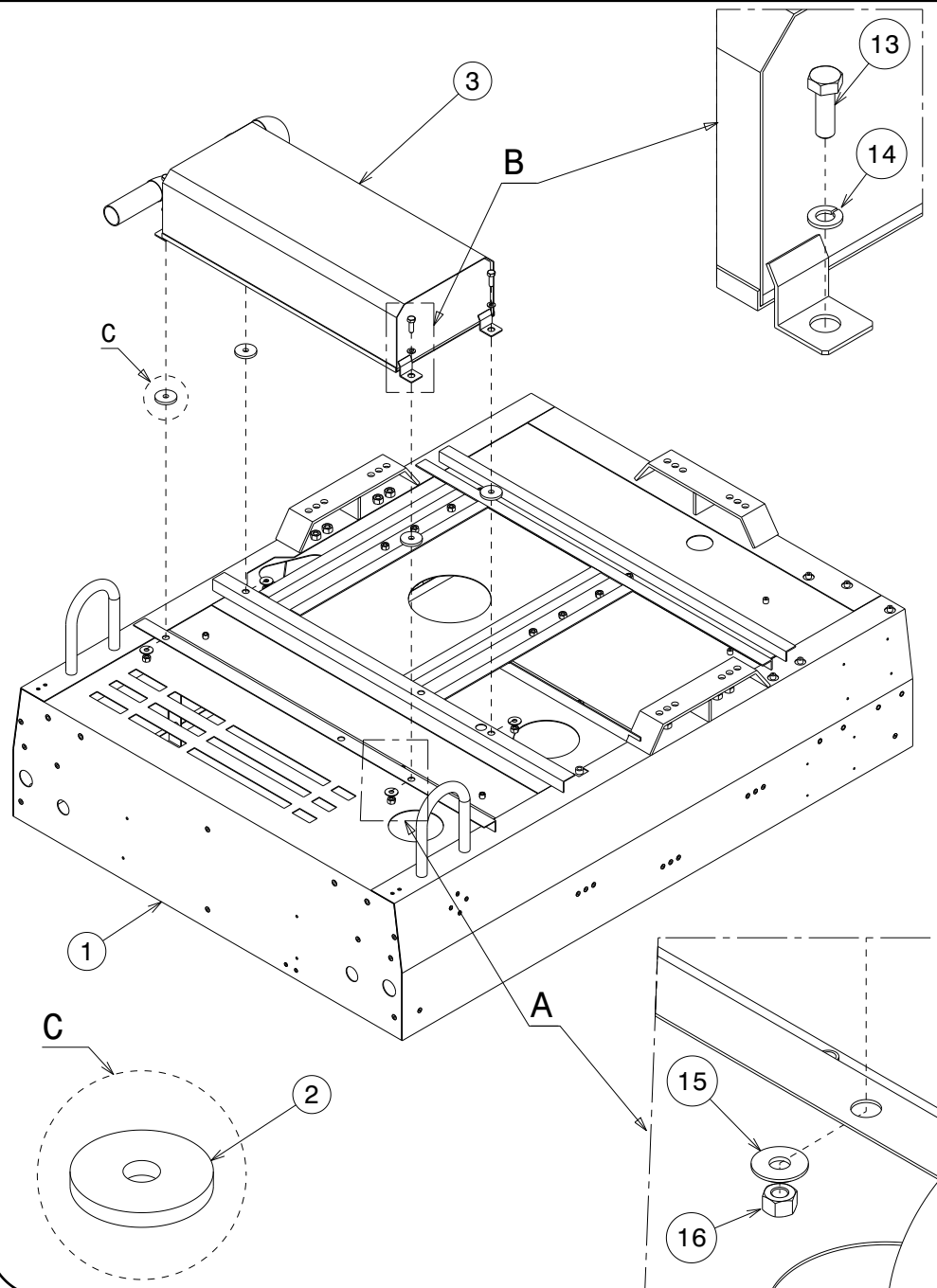



PARTS LIST

Motocompressor – D90 KA

PARTS LEGENDA: Gasoil tank – Muffler- Battery

Tab. 04

REF	NAME		CODE	QUANTITY
1	Chassis		038-0910-S	1
2	Muffler seal d.40 sp.5 d.40 sp.5		023-077-S	4
3	Muffler		042-06660-S	1
4	Gasoil tank		201-040101-S	1
	Gasoil tank (serial no. C37556-C37557)		201-013-S	1
5	Gasoil tank plug		193-0180-S	1
6	Battery		174-007-S	1
7	Gasoil filter clamping blade		120-364-S	1
8	Gasoil filter	From serial no.C38935+C38742 and C38743	191-0690-S	1
	Gasoil filter	Up to serial no.C38934	191-070-S	1
9	Gasoil tank rubber plate		177-185-S	1
10	Battery clamping blade		115-009-S	3
11	Positive battery cable		252-054-S	1
12	Negative battery cable		252-055-S	1
13	Hex head screw M8x25 UNI 5739		132-102-S	6
14	Elastic washer d.8		139-040-S	4
15	Flat washer 8x24x2 UNI6593		015-031-S	4
16	Hex nut M8 UNI 5587		135-040-S	4
17	Hex head screw . M6x20		132-063-S	8
18	Washer d.6		015-250-S	8
19	Flat washer 6,6x12x1,5 DIN125/1		015-027-S	8
20	Flat washer 8,4x17x1,5 UNI 6592		015-030-S	4
21	Self-locking nut M8 UNI 7473		137-040-S	2
22	Washer d. 6.6x18x2		015-029-S	2

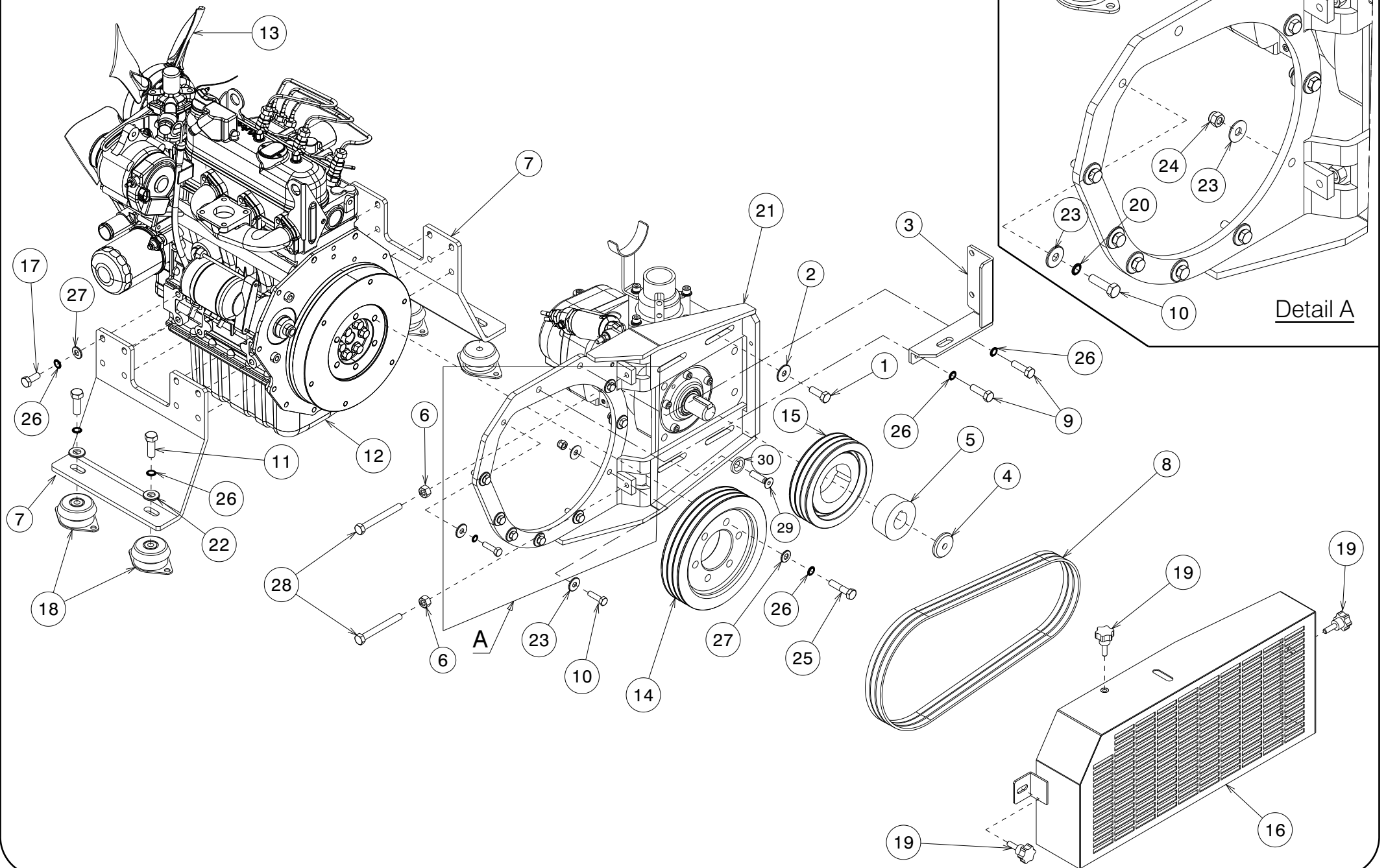



PARTS LIST

Motocompressor – D90 KA

PARTS LEGENDA: Engine - Airend

Tab. 05.0

REF	NAME		CODE	QUANTITY
1	Hexagonal head screw M10x30 UNI 5739		132-143-S	3
2	Flat washer 10x30x2,5 UNI6593		015-0328-S	3
3	Engine air filter support	Up to serial no.C37556	010-3052-S	1
	Engine air filter support	From serial no.C38460	010-30522-S	1
4	Compressor joint washer		015-063-S	1
5	Conical bush D.30		959-02505-S	1
6	Exagonal nut M10		135-050-S	4
7	Engine support		039-122120-S	2
8	Belts XPZ 1080 QUAD POWER IV		156-45351-S	3
9	Hex head screw M10x35 UNI 5739		132-144-S	2
10	Hex head screw M8x30		132-103-S	9
11	Hex head screw screw		132-193-S	5
12	Kubota Engine D1105		165-4004-S	1
13	Fan		083-4070-S	1
14	Motor pulley 3g.dp.200		050-47220-S	1
15	Compressor pulley 3g. dp.150		050-54160-S	1
16	Belts protection grid panel		124-29791622-S	1
	Belts protection grid panel	From to serial No. C39490 up to C43677	124-29791621-S	1
	Belts protection grid panel	From serial No. C38460 up to C38989	124-2979162-S	1
	Belts protection grid panel	Up to serial No. C37556	124-297916-S	1
17	Screw Hex.H. M 10x25x1,25		132-1425-S	16
18	Silent block MD 3 SDD40		061-05051-S	2
19	Knob	From serial No. C38460	185-0185-S	3
20	Schnorr washer d.8		015-251-S	6
21	Engine air end support		010-2325021-S	1
22	Flat washer d. 13		015-047-S	2
23	Flat washer 8x24x2 UNI6593		015-031-S	12
24	Self-locking nut M8 UNI 7473		137-040-S	3
25	Screw Hex.H. M 10x45x1,25		132-146.5-S	6
26	Washer d.10		015-252-S	26
27	Plane washer 10,2x21x2		015-032-S	22
28	Screw Hex.H. M.10x 90		132-1551-S	2
29	Socket head cap screw M10x30 UNI5933		146-153-S	1
30	Spacer		009-2701-S	1

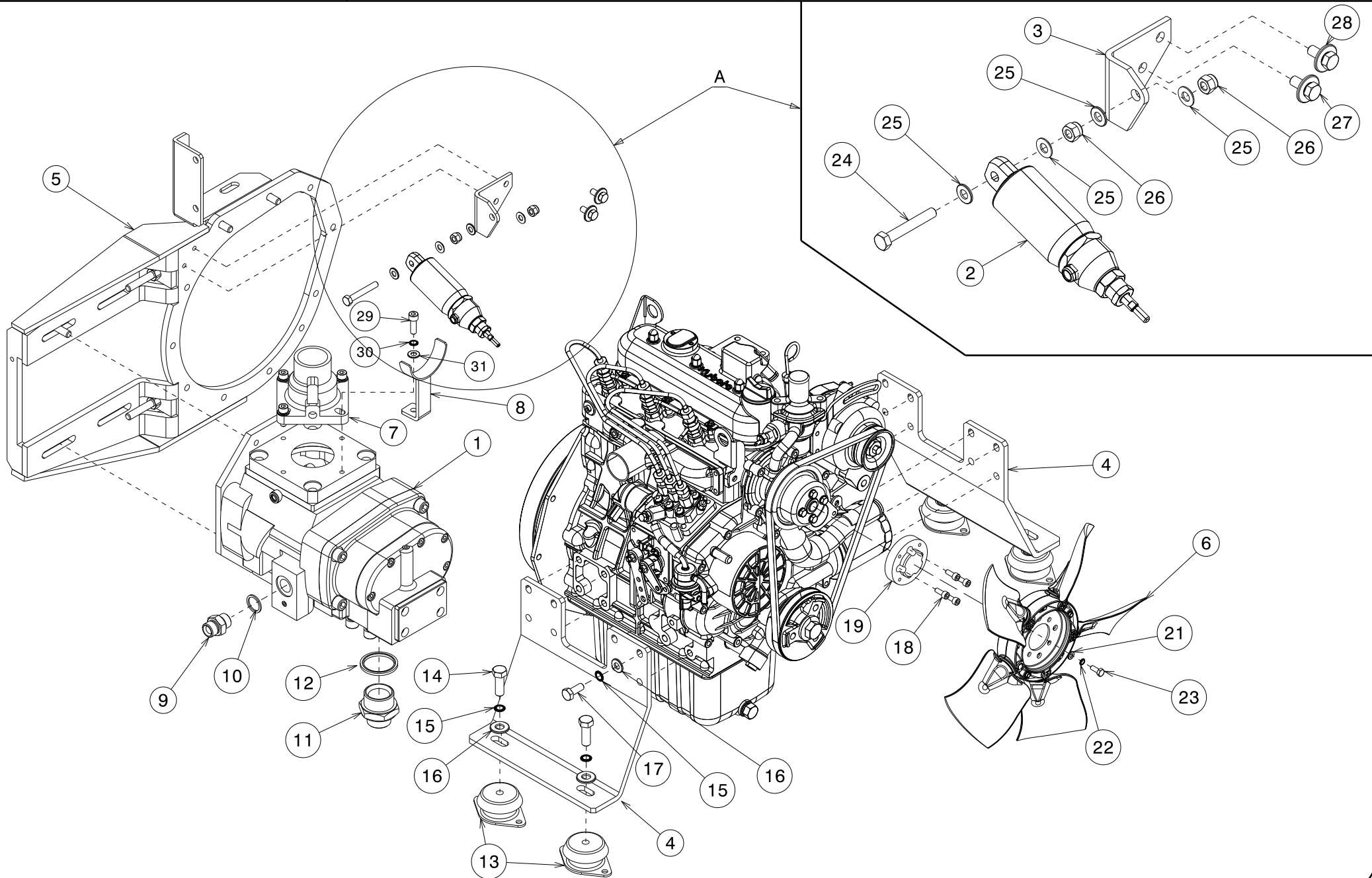



PARTS LIST

Motocompressor – D90 KA

PARTS LEGENDA: Air end assembly

Tab. 05.1

REF	NAME	CODE	QUANTITY
1	Air end assembly	024-03291021-S	1
	Air end assembly	From C39236 - Up to C39643 024-041-F	1
2	Accelerator piston assembly	044-0040522-S	1
3	Accelerator piston support	010-10661-S	1
4	Engine support	039-122120-S	2
5	Air end support	010-2325021-S	1
6	Fan	083-4071-S	1
7	Regulator assembly	024-138151-S	1
8	Air filter support	120-384502-S	1
9	Double screw (1/2")	187-045-S	1
10	Copper washer	015-0121-S	1
11	Double screw (1" to " 1/4)	187-075-S	1
12	Bonded washer 1 1/4"	015-204-S	1
13	Silent block	061-050-S	2
14	Hex head screw screw	132-193-S	2
15	Schnorr washer d.10	015-252-S	2
16	Flat washer d. 13	015-047-S	10
17	Hex head screw M.10x25x1,25 UNI5740	132-1425-S	8
18	Flat washer 10,2x21x2	015-032-S	8
19	Fan spacer	009-12164-S	1
20	Hex socket head cap screw M6x16 UNI 5931	133-091-S	4
21	Flat washer 6,6x12x1,5 DIN125/1	015-027-S	4
22	Washer d.6	015-250-S	4
23	Hexagonal head Screw M6x16 UNI 5739	132-062-S	4
24	Hex head screw M8x55 UNI 5737	132-108-S	1
25	Flat washer 8,4x17x1,5 UNI 6592	015-030-S	4
26	Self locking nut M8 UNI 7473	137-040-S	2
27	Hex head screw M8x20 UNI 5739	132-101-S	2
28	Flat washer 8x24x2 UNI6593	015-031-S	2
29	Hex socket head cap screw M8x25 UNI 5931	133-133-S	4
30	Schnorr washer d.8	015-251-S	4
31	Flat washer 8,4x17x1,5 UNI 6592	015-030-S	4

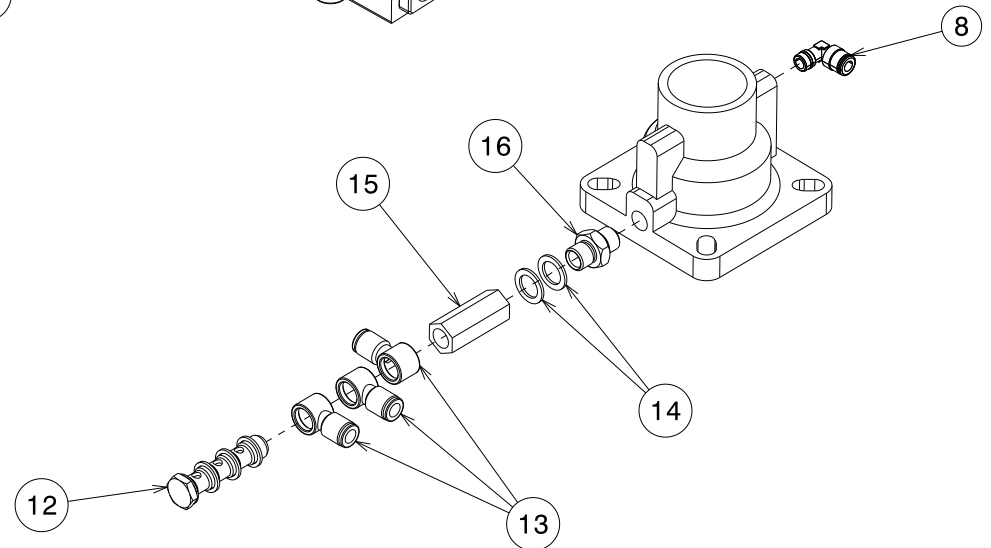
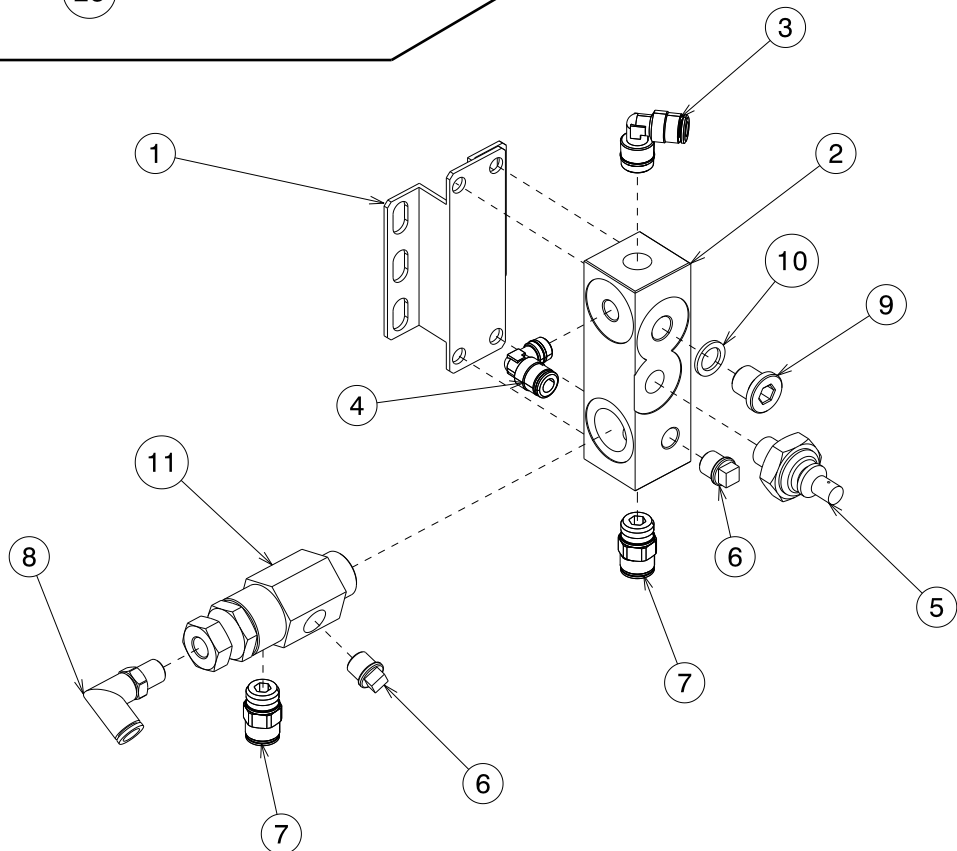
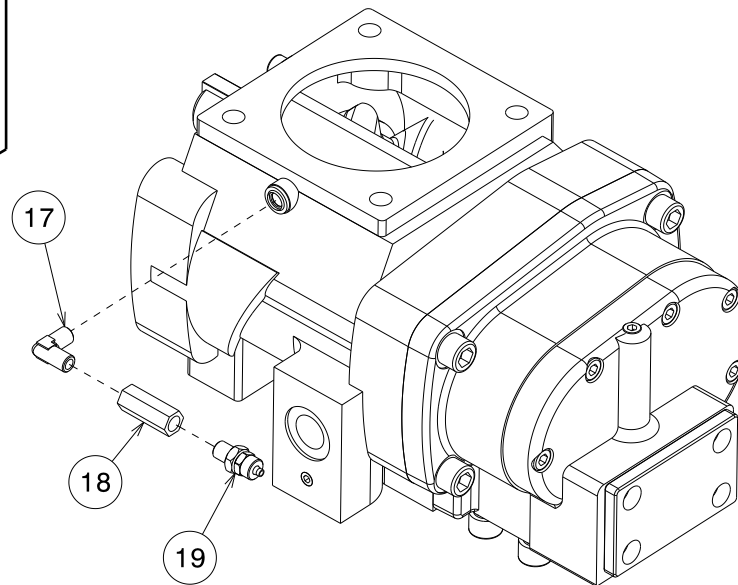
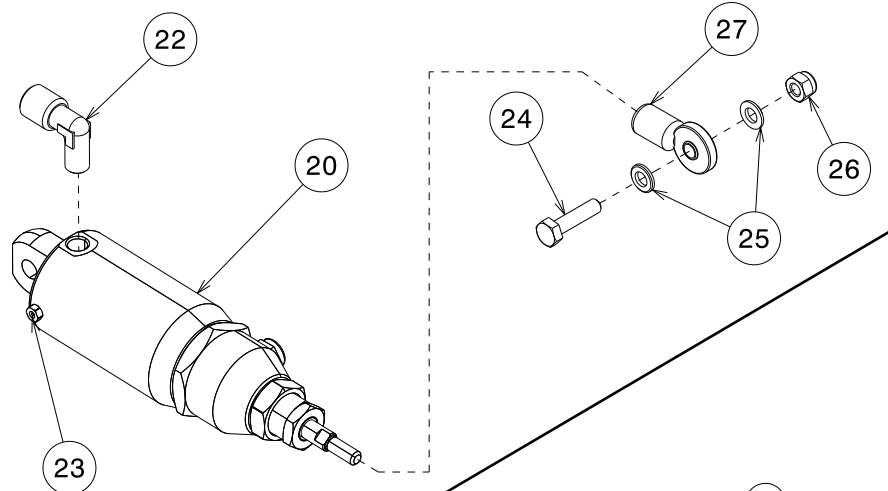

Motocompressor – D90 KA**PARTS LEGENDA:** Connections – Accelerator piston

Tab. 05.2

REF	NAME	CODE	QUANTITY
1	Valves group support	010-314-S	1
2	Devices coupling block	053-300-S	1
3	Quick coupling 90° 1/4" for pipe d. 8	148-573.5-S	1
4	Quick coupling 90° (1/8") for pipe d. 6	148-570-S	2
5	Oil pressure switch 1.4 bar	154-030-S	1
6	Square head plug (1/8")	106-020-S	1
7	Straight quick coupling (1/4") for pipe d.8	148-575-S	1
8	Straight quick coupling (1/8")	148-8001-S	2
9	Hexagonal head plug (M12x1.5)	106-092-S	1
10	Copper washer (1/8")	015-005-S	1
11	Pressure regulation valve assembly	024-032.1-F	1
12	Quick coupling (1/4")	148-5900-S	1
13	Super quick coupling (1/4")	148-5901-S	3
14	Copper washer (1/4")	015-007-S	2
15	Non return valve 1/4" P<10 bar	033-017-S	1
16	Double screw (1/4")	187-006-S	1
17	Adapter fitting 90° M+M (1/8")	148-288-S	1
18	Non return valve (1/8")	033-001-S	1
19	Straight coupling (1/8") for pipe d.6	148-040-S	1
20	Accelerator piston assembly	044-0040522-S	1
22	90° quick coupling (1/8") for pipe d.8	148-572-S	1
23	Screw with conical hexagon (1/8")	218-001-S	1
24	Hex head screw screw M6x25 UNI 5739	132-065-S	1
25	Flat washer 6,6x12x1,5 DIN125/1	015-027-S	2
26	Hex nut M6 UNI 7473	137-030-S	1
27	Accelerator piston articulated joint	236-021-S	1

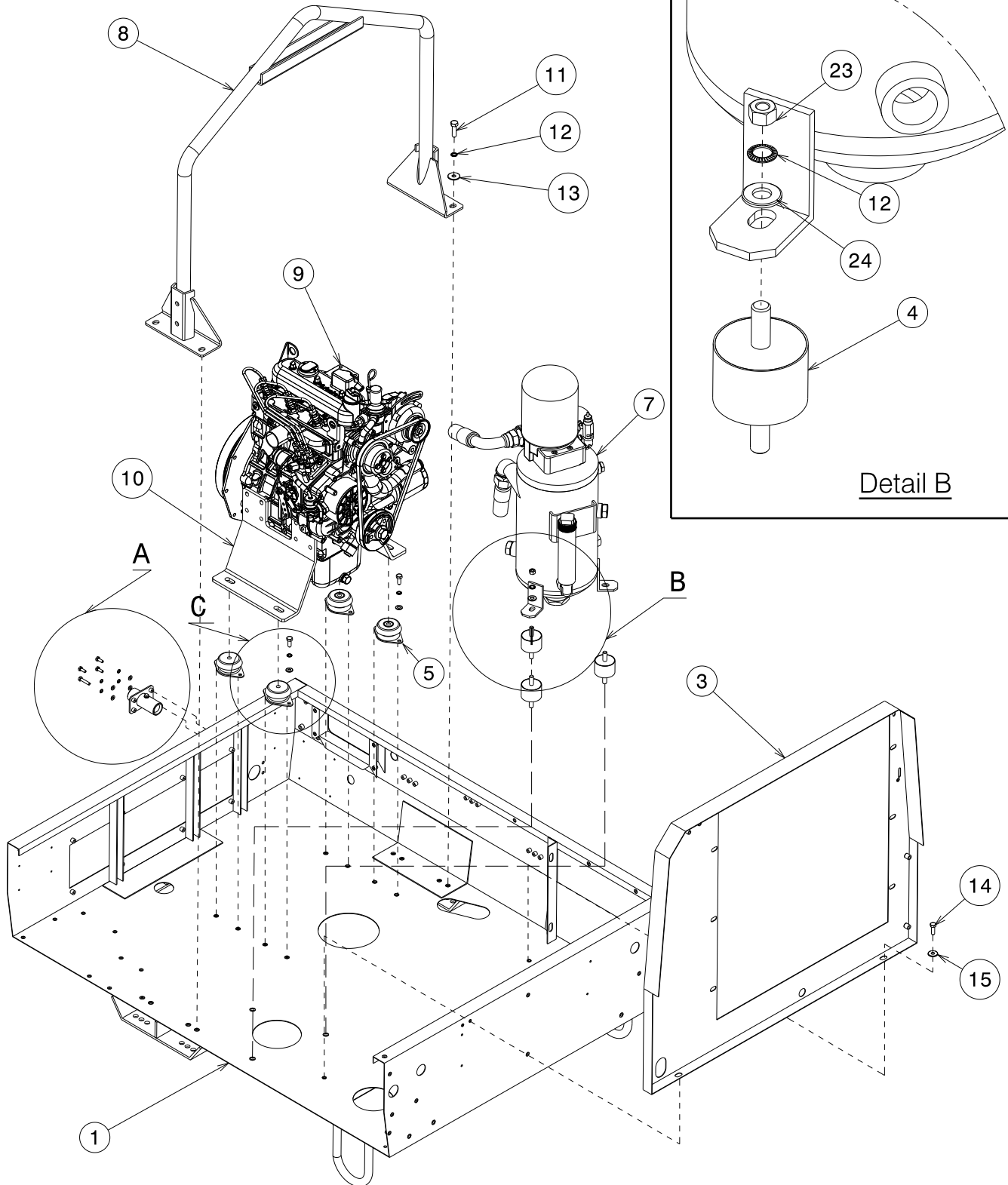
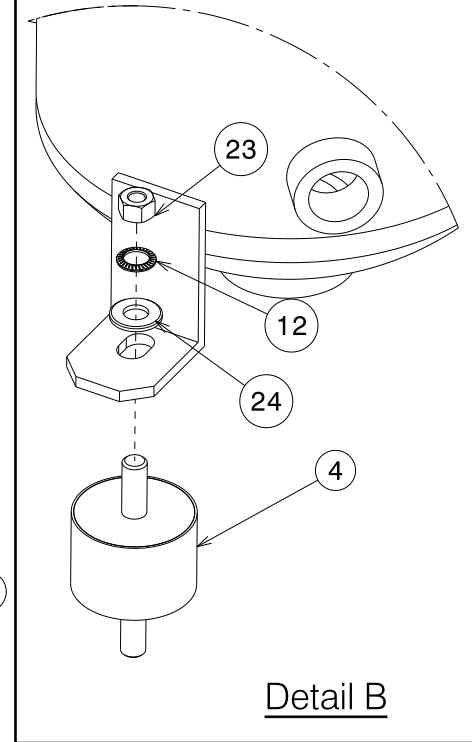
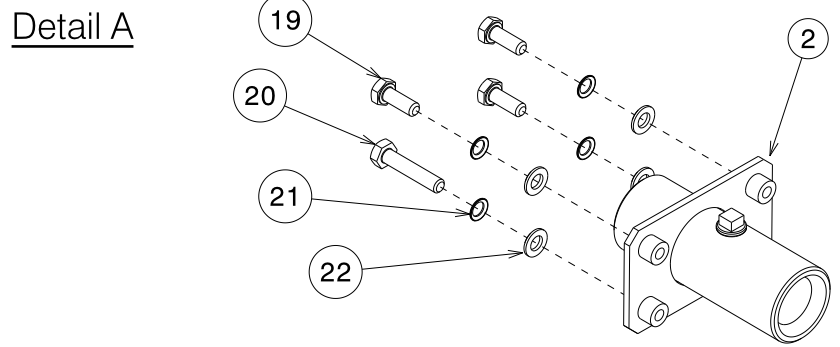
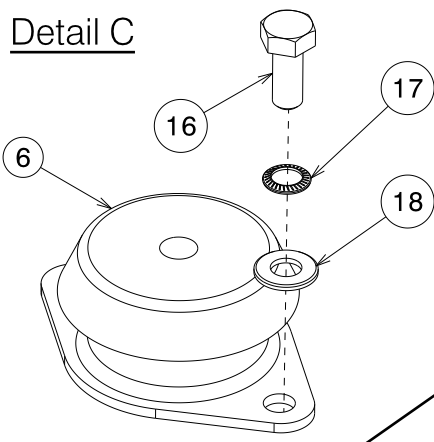



PARTS LIST

Motocompressor – D90 KA

PARTS LEGENDA: Clampings to the frame

Tab. 06

REF	NAME	CODE	QUANTITY
1	Chassis	038-0910-S	1
2	Exit valves clamping sleeve	063-10310-S	1
3	Radiator support	049-11021-S	1
4	Silent block Separator tank	061-0112-S	3
5	Silent block engine support	061-05050-S	2
6	Silent block engine support	061-05051-S	2
7	Separator tank assembly (2.7 gal -10lt)	024-60612-F	1
8	Hoisting hook (Up to Serial No. C39643)	017-04550-S	1
	Hoisting hook (From Serial No. C39644)	017-045501-S	1
9	Engine	165-4004-S	1
10	Engine support	039-122120-S	2
11	Hex head screw M10x35 UNI 5739	132-144-S	4
12	Schnorr washer d.10	015-252-S	7
13	Flat washer 10x30x2,5 UNI6593	015-033-S	4
14	Hex head screw M8x25 UNI 5739	132-102-S	2
15	Flat washer 8x24x2 UNI6593	015-031-S	2
16	Hex head screw . M8x20 UNI 5739	132-101-S	8
17	Schnorr washer d.8	015-251-S	8
18	Flat washer 8,4x17x1,5 UNI 6592	015-030-S	8
19	Hexagonal head Screw M6x16 UNI 5739	132-062-S	3
20	Hexagonal head Screw M6x30 UNI 5739	132-066-S	1
21	Washer d.6	015-250-S	4
22	Flat washer 6,6x12x1,5 DIN125/1	015-027-S	4
23	Hex nut M8 UNI 5587	135-040-S	3
24	Flat washer 10,2x21x2	015-032-S	3

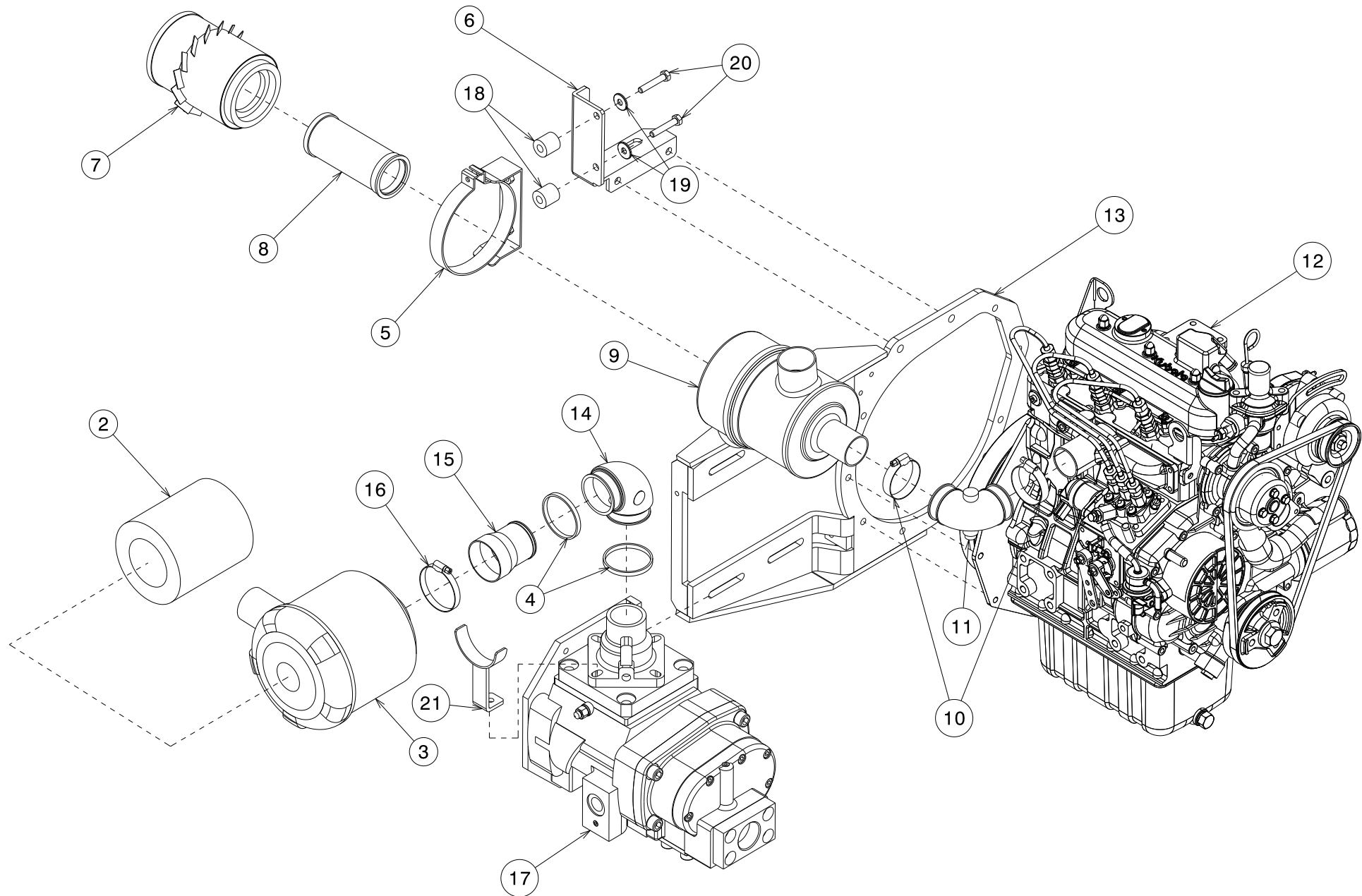



PARTS LIST

Motocompressor – D90 KA

PARTS LEGENDA: Air filters

Tab. 07

REF	NAME	CODE	QUANTITY
1	Pressure regulation valve assembly	024-138151-F	1
2	Air filter	162-0075-S	1
3	Engine filter group	014-423-S	1
4	Pipe clamp d.40x60	149-135-S	2
5	Engine air filter support clamp	149-384-S	1
6	Engine filter group support	From serial No. C38460	1
	Engine filter group support	010-3052-S	1
7	First stage engine air filter	162-112-S	1
8	Second stage engine air filter	162-113-S	1
9	Engine air filter	014-397-S	1
10	Pipe clamp d.35-50	149-131-S	4
11	Short radius curve	111-103-S	1
12	Kubota engine D1105	165-4004-S	1
13	Airend support	010-2325021-S	1
14	Elbow for regulator air suction	111-102-S	1
15	Reduction 60-52	190-60396-S	1
16	Pipe clamp d.50x70	149-140-S	1
17	Airend	024-03291021-S	1
18	Spacer	009-2395-S	2
19	Flat washer UNI 6593	015-031-S	2
20	Hex head screw M8x45 UNI 5739	132-106-S	2
21	Air filter group support blade	120-384502-S	1

Rear view

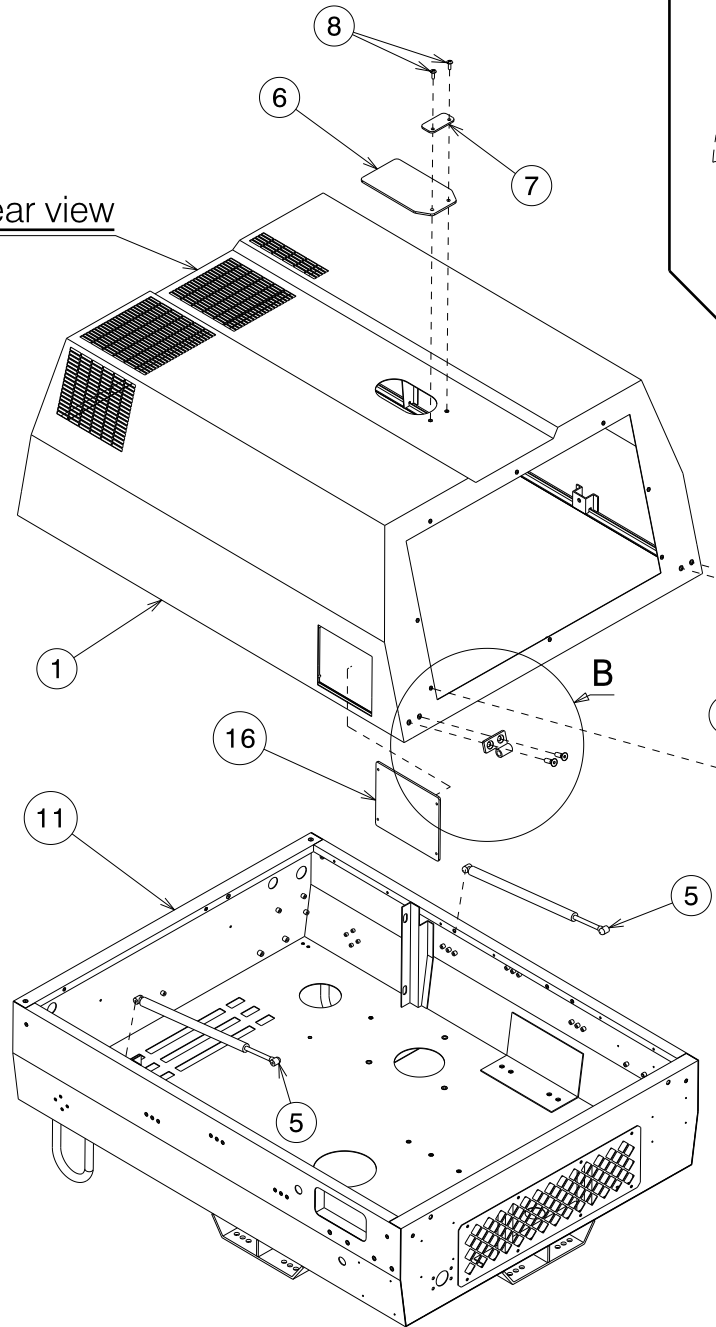

Detail A

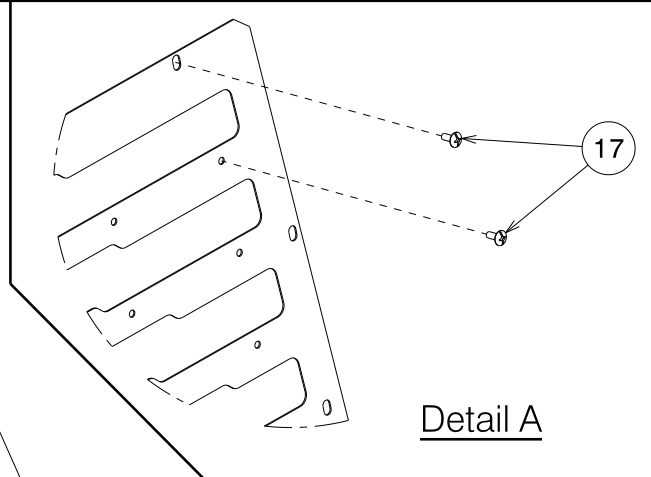

Rear view

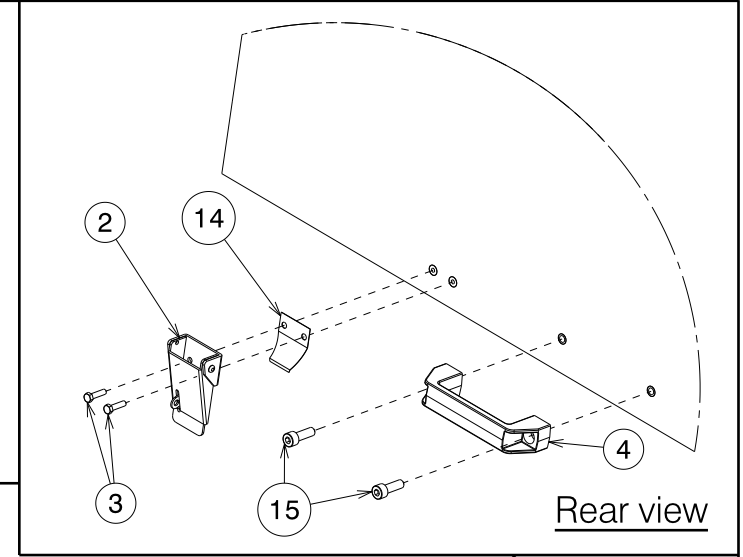

Detail B

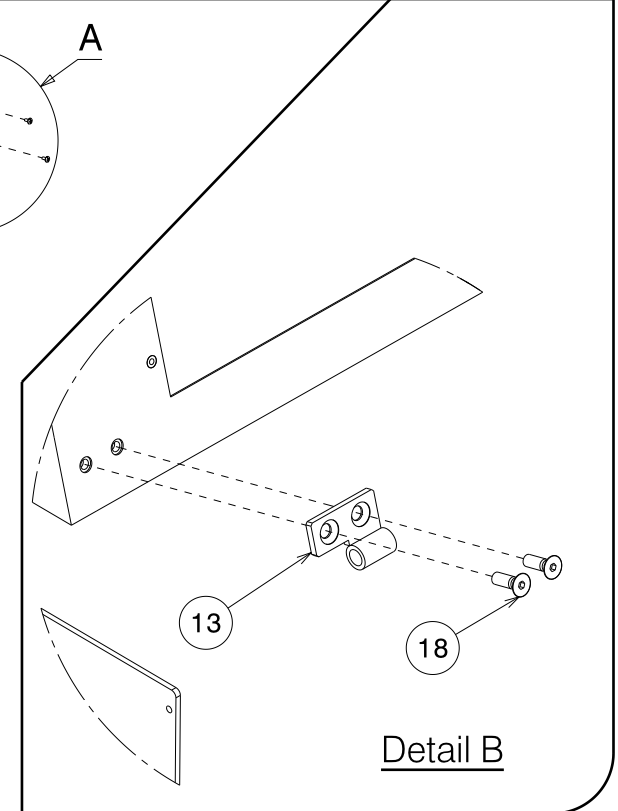



PARTS LIST

Motocompressor – D90 KA

PARTS LEGENDA: Hood assembly

Tab. 08

REF	NAME	CODE	QUANTITY
1	Canopy (Up to Serial No. C39643)	036-1610-S	1
	Canopy (From Serial No. C39644)	036-16102-S	1
2	Lock	128-010-S	1
3	Hex head screw M5x20 UNI 5739	132-040-S	2
4	Handle	209-009-S	1
5	Lifting piston (Up to serial No.C37557)	091-094-S	2
	Lifting piston (From serial No. C38221 up to C38741)	091-09470-S	2
	Lifting piston (From serial No.C38742)	091-09380-S	2
6	Rubber plate for hosting hook	177-200-S	1
7	Rubber holding plate	208-004-S	1
8	6x20 poelier screw	243-010-S	2
9	Air intake sound-proof panel	124-2948505-S	4
10	Air intake	022-01105-S	1
11	Chassis	038-0910-S	1
12	Left hinge	007-007502-S	1
13	Right hinge	007-007500-S	1
14	Lock spring	043-0335-S	1
15	Hex socket head cap screw M8x25 UNI 5931	133-133-S	4
16	Plexiglass door	057-02700-S	1
17	6x16 poelier screw	243-009-S	32
18	Hexagon socket countersunk head 10x20 UNI 5933	146-151-S	4

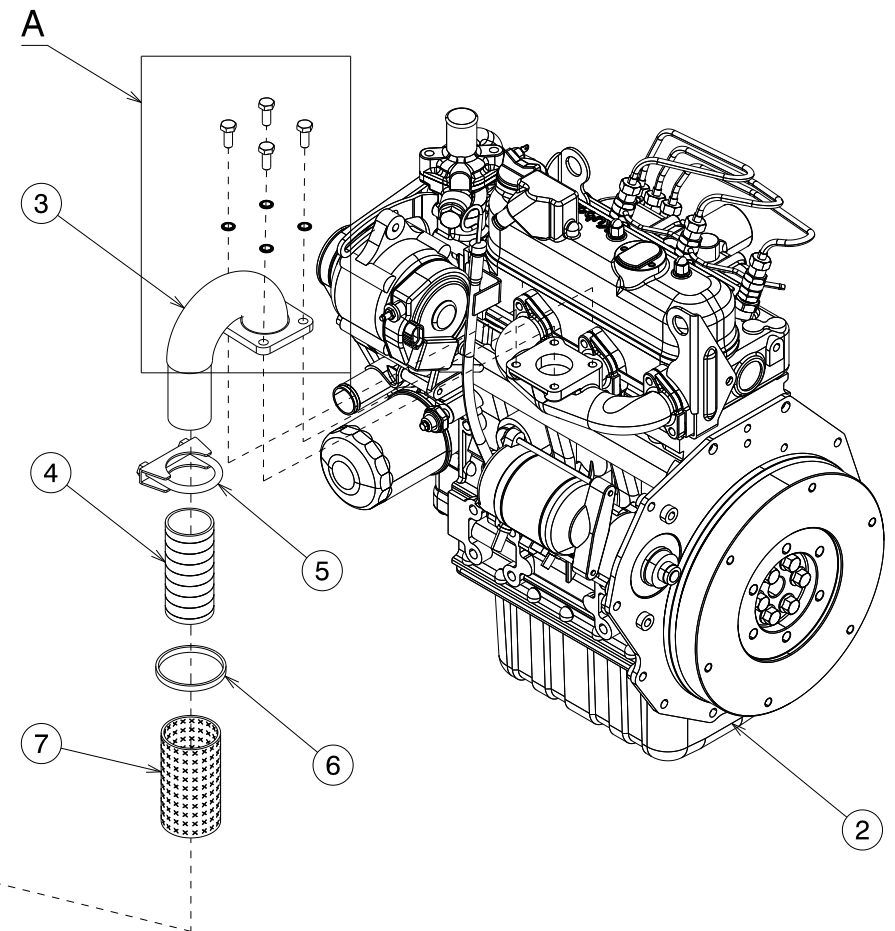
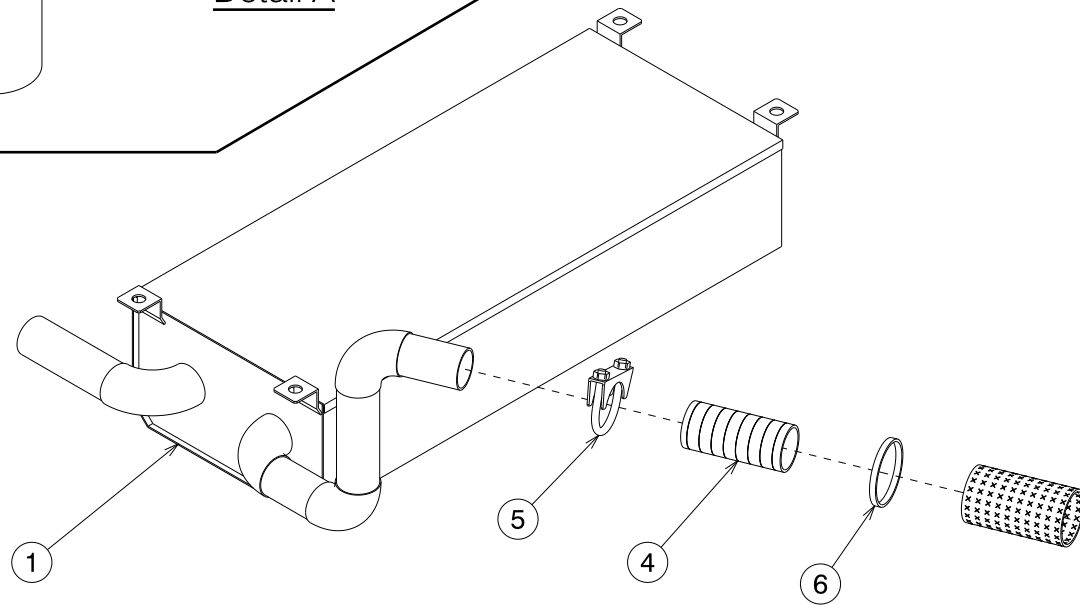
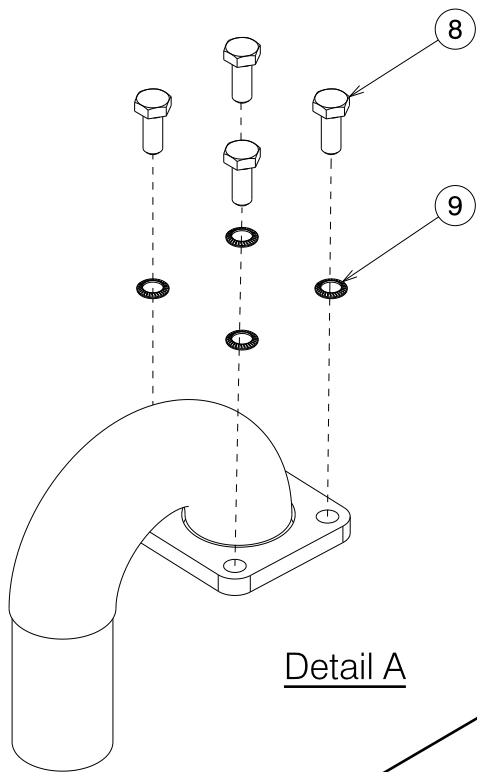



PARTS LIST

Motocompressor – D90 KA

PARTS LEGENDA: Exhaust system

Tab. 09.1

POSIZIONE	DESCRIZIONE	CODICE	QUANTITA'
1	Muffler	042-06660-S	1
2	Engine	165-4004-S	1
3	Collector – muffler extension	119-04910-S	1
4	Inox pipe d.40 Lenght=600mm	090-0085-S	1
5	Pipes clamp diam.45x8	149-054-S	2
6	Pipes clamp d.40/60	149-135-S	2
7	Fiber glass braiding (d.40)	097-0305-G	1
8	Hex head screw M8x20 UNI 5739	132-101-S	4
9	Schnorr washer d.8	015-251-S	4

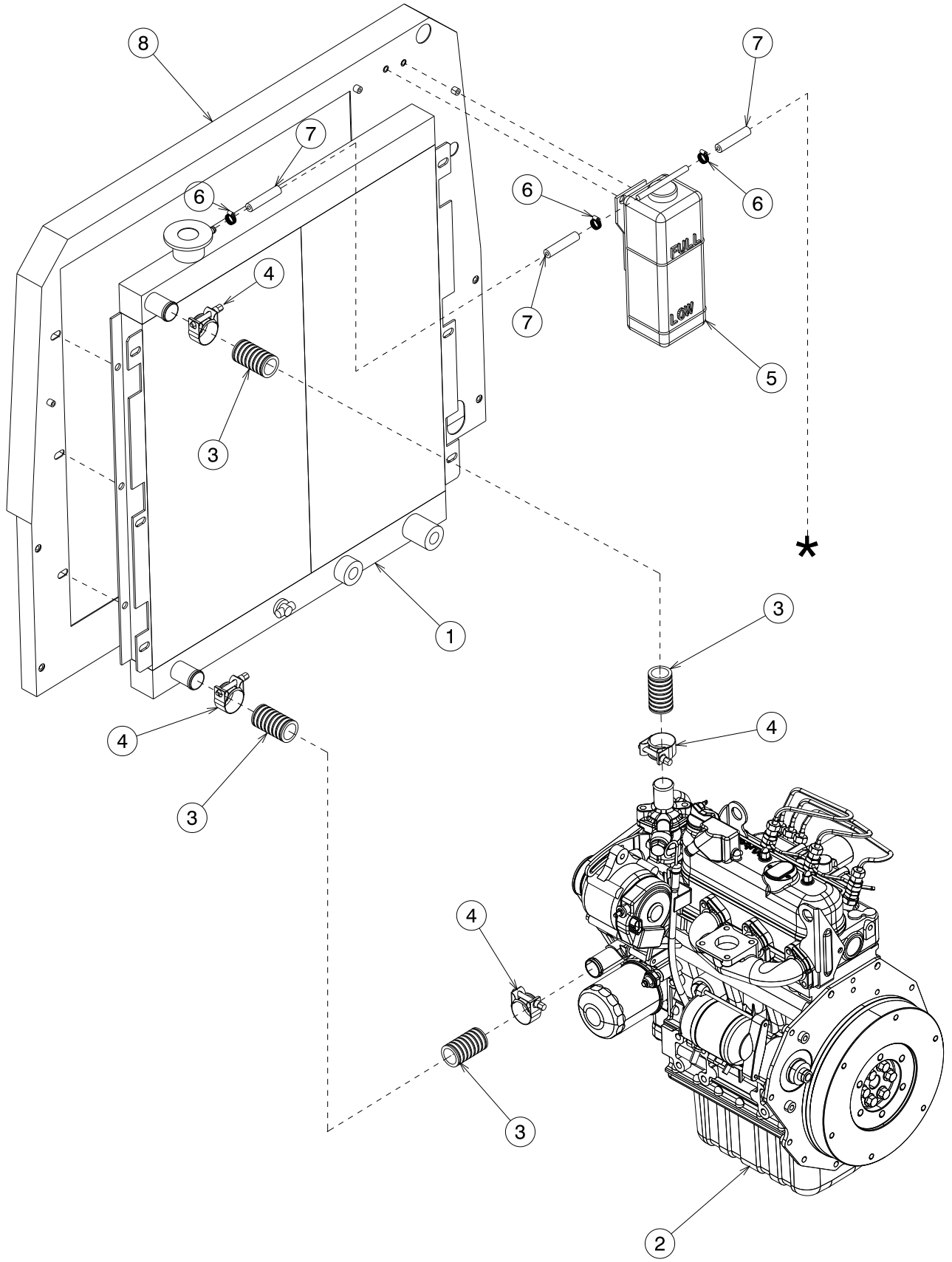



PARTS LIST

Motocompressor – D90 KA

PARTS LEGENDA: Cooling system

Tab. 09.2

REF	NAME	CODE	QUANTITY
1	Water – Air Radiator	011-09141-S	1
2	Engine	165-4004-S	1
3	Pipe diam.28x36 (Upper pipe) Lenght=540mm	089-009-S	2
	Pipe diam.28x36 (Lower pipe) Lenght=640mm		
4	Pipe sa 34-37	149-308-S	4
5	Expansion tank kit	044-098065-S	1
6	Clamp diam 10x16	149-007-S	3
7	Anti-oil pipe for fuel 13x6	089-110-S	2
8	Radiator support	049-11021-S	1
*	Drain bottom the frame		

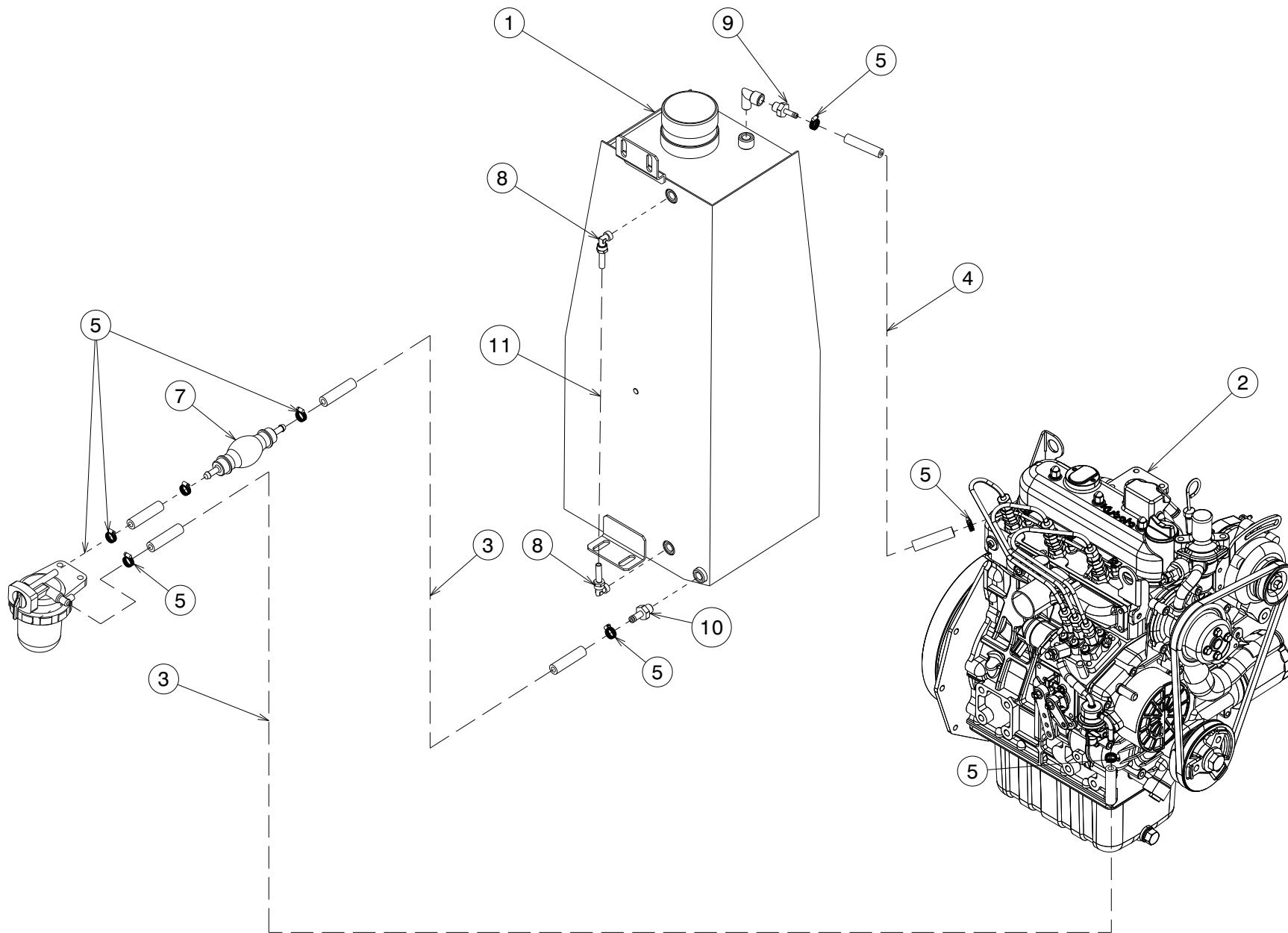



PARTS LIST

Motocompressor – D90 KA

PARTS LEGENDA: Fuel system

Tab. 09.3

REF	NAME	CODE	QUANTITY
1	Gasoil tank	201-040101-S	1
2	Engine	165-4004-S	1
3	Anti-oil pipe for fuel 15x8 Lenght=300 -200-350-1070 mm	089-120-S	1
4	Anti-oil pipe for fuel 13x6 Lenght=1800mm	089-110-S	1
5	Pipe clamp d. 10x16	149-007-S	8
6	Gasoil filter	191-070-S	1
7	Petrol pump	021-0305-S	1
8	90° fitting (1/4") for pipe d.8	148-110-S	2
9	Fitting M (1/4") for pipe d.6 + OR	148-198.11-S	1
10	Fitting M (1/4") for pipe d.8 + OR	148-198.21-S	1
11	Rylsan pipe d.8 white	089-060-S	1

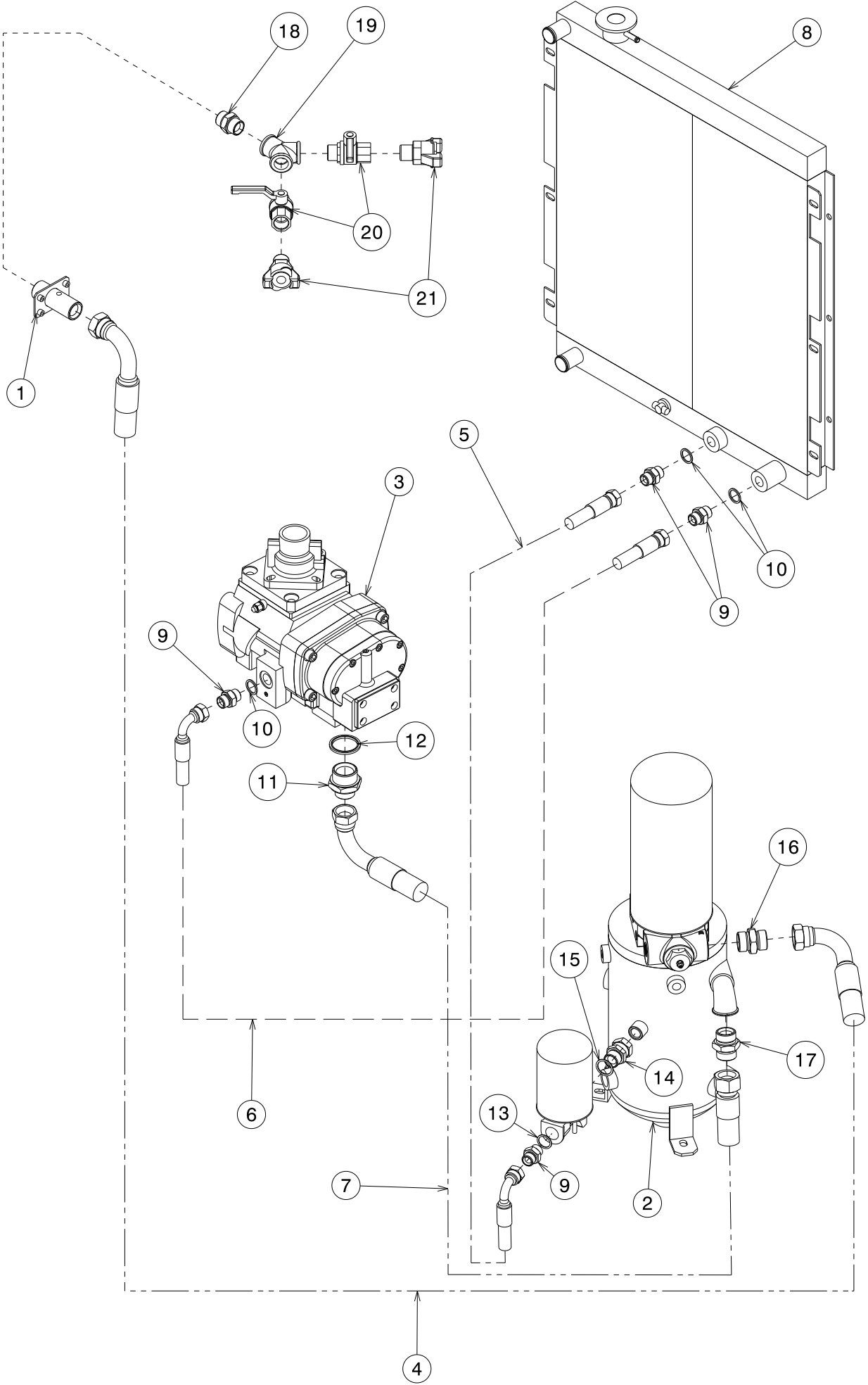



PARTS LIST

Motocompressor – D90 KA

PARTS LEGENDA: Connections

Tab. 09.4

REF	NAME	CODE	QUANTITY
1	Taps connections	063-10310-S	1
2	Separator tank (2.7 - 10 lt)	037-00101-F	1
3	Air End assembly	024-03291021-F	1
4	Pipe (1")	065-874.500-S	1
5	Pipe (1/2")	065-576.1-S	1
6	Pipe (1/2")	065-584.3-S	1
7	Pipe (1")	065-853.5957-S	1
8	Water – oil radiator	011-09141-S	1
9	Double screw 1/2 foro 12,6	187-045-S	4
10	Copper washer d.int.21x27x2 (1/2)	015-0121-S	3
11	Double screw 1 a 1 1/4	187-075-S	1
12	Bonded washer 1 1/4	015-204-S	1
13	Copper washer (1/2)	015-012-S	1
14	Rotating straight adapter fitting M+F 3/4	148-005-S	1
15	Copper washer (3/4")	015-015-S	1
16	Double screw 1" – 1/4 foro 25,5	187-070-S	1
17	Double screw 1"	187-069-S	1
18	Double screw 3/4"	187-061-S	1
19	"Y" fitting d.3/4"	148-530-S	1
20	Ball valve connection M+F (3/4")	152-030-S	2
21	Bayonet fitting 3/4"	148-651-S	2

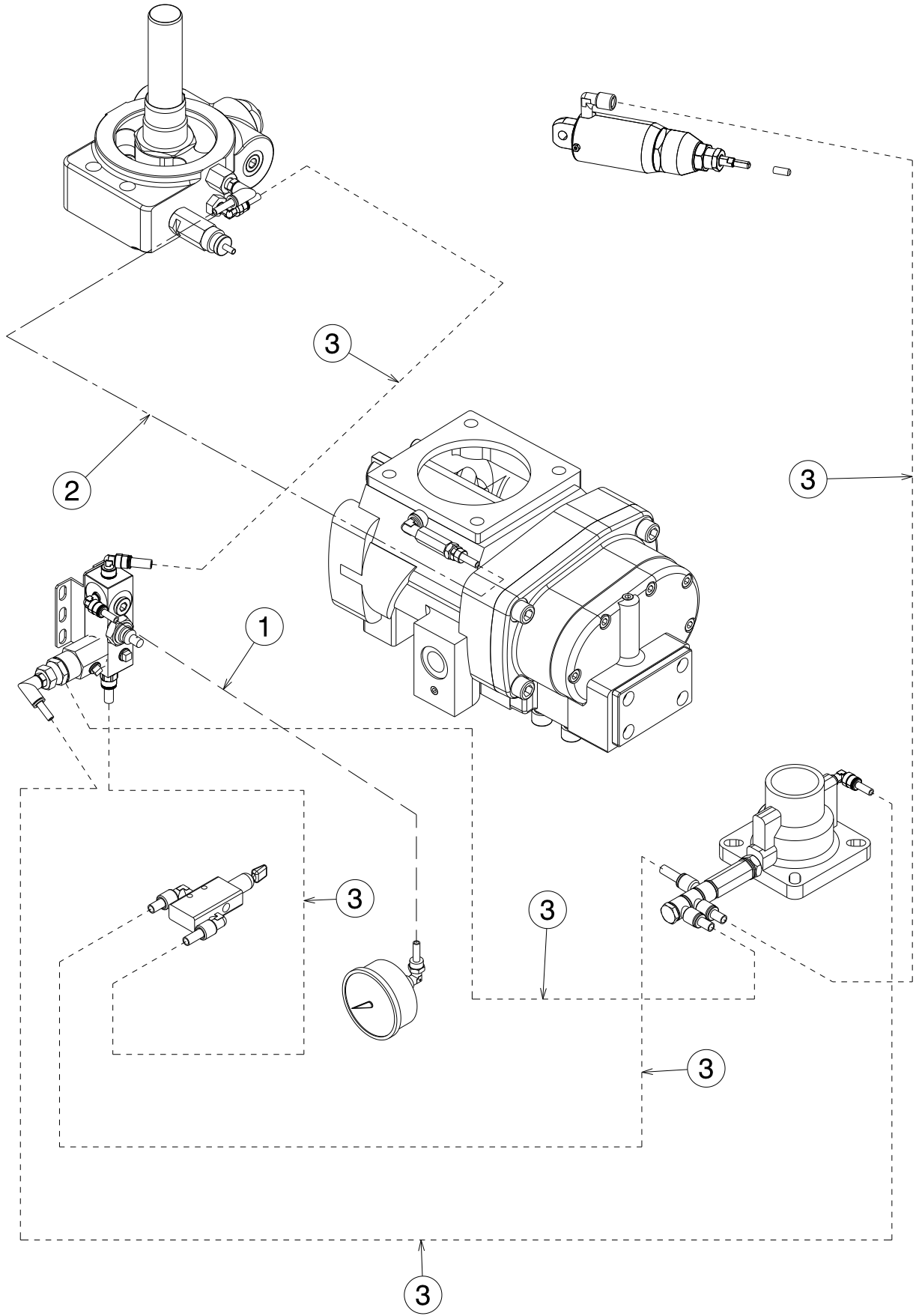



PARTS LIST

Motocompressor – D90 KA

PARTS LEGENDA: Pneumatic system

Tab. 09.5

REF	NAME	CODE	QUANTITY
1	Rilsan pipe blue 6x4	089-0605-S	1
2	Polyamides white pipe 6x4	089-060-S	1
3	Rilsan pipe blue 8x6	089-0705-S	5



90KA

3

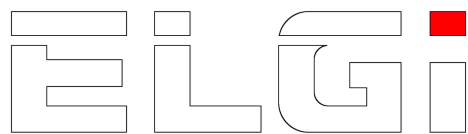

5



4

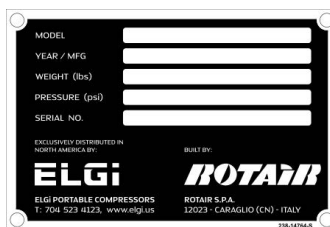

9

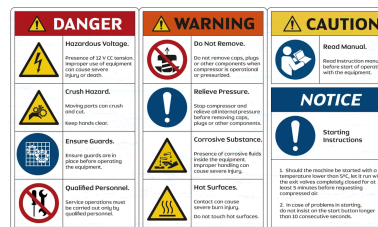

10

8

2

1

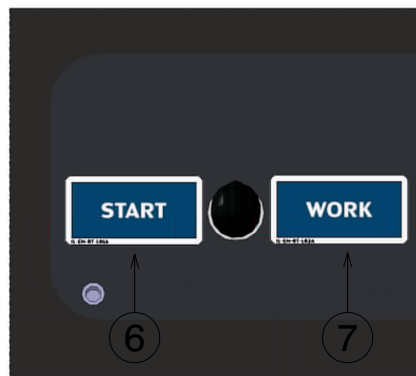

6

7



8

5

9

3

10

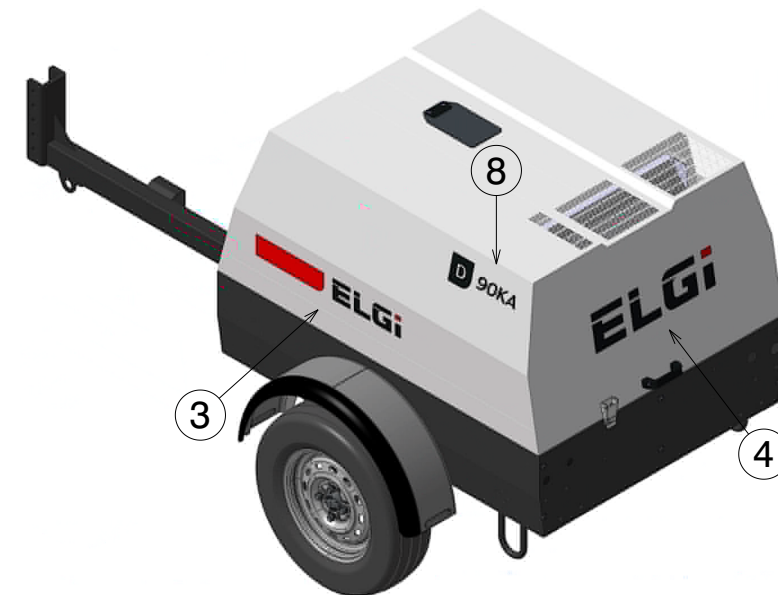

8

4

3



PARTS LIST

Motocompressor – D90 KA

PARTS LEGENDA: Decals

Tab. 10

REF	NAME	CODE	QUANTITY
1	Satiny air filter decal	238-001-S	1
2	Satiny oil filter decal	238-002-S	1
3	"ELGI Brand" decal	238-3274010-S	2
4	"ELGI black" decal	238-3274018-S	1
5	"ELGI white" decal	238-3274014-S	1
6	"Start" decal	238-01020-S	1
7	"Work" decal	238-01022-S	1
8	D90 KA decal	238-325802-S	2
9	Moto-compressor serial no. plate	238-14764-S	1
10	"Warnings" decal	238-01030-S	1

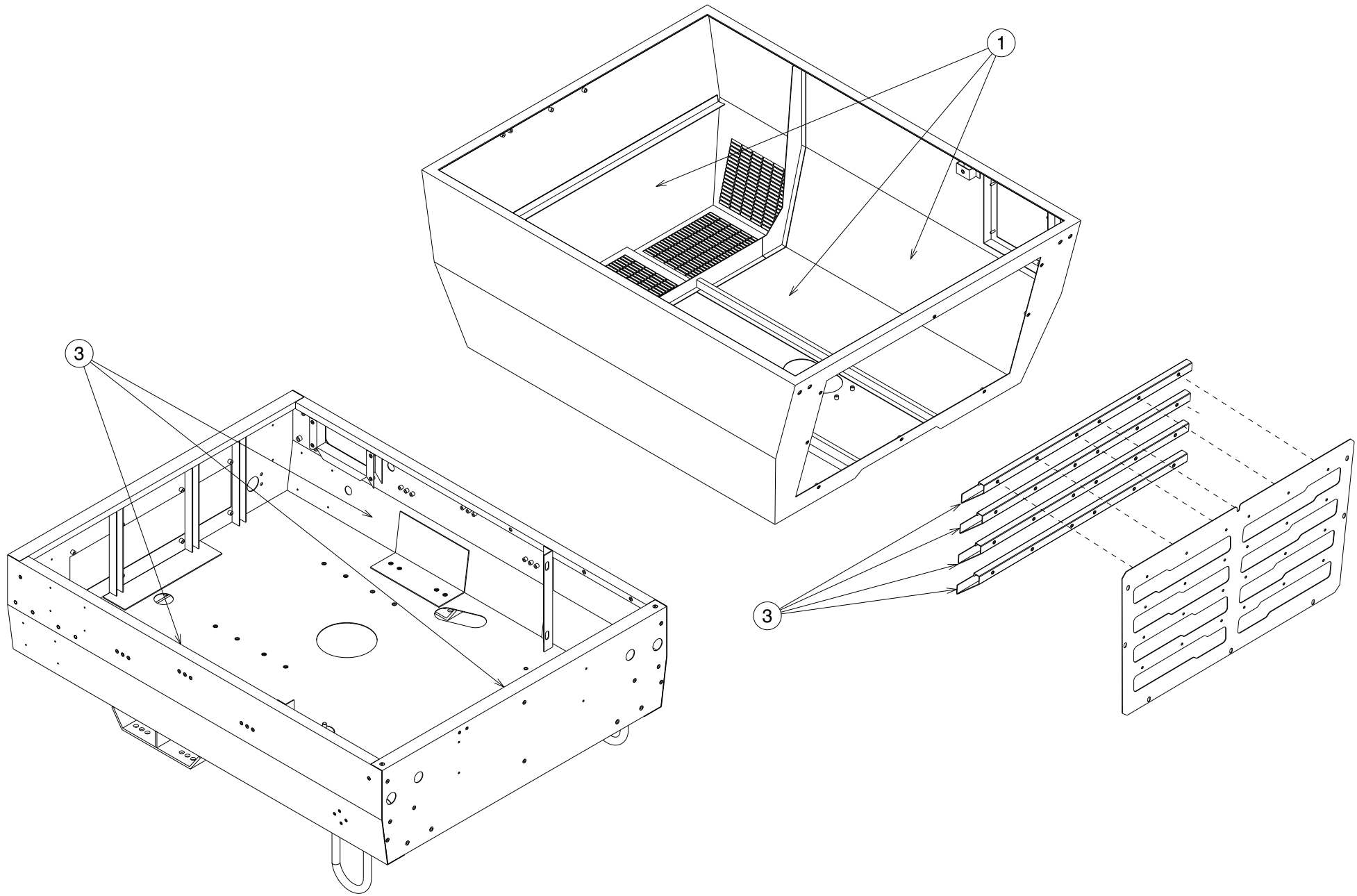



PARTS LIST

Motocompressor – D90 KA

PARTS LEGENDA: Sound proofing Kit

Tab. 11

REF	NAME	CODE	QUANTITY
1	Canopy soundproofing kit	204-3240702-S	1
2	Air intake soundproofing kit	204-324073-S	4
3	Chassis soundproofing kit	204-324074-S	1

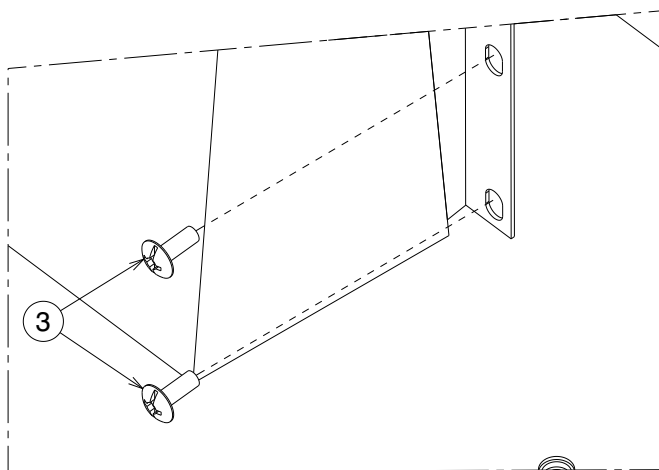
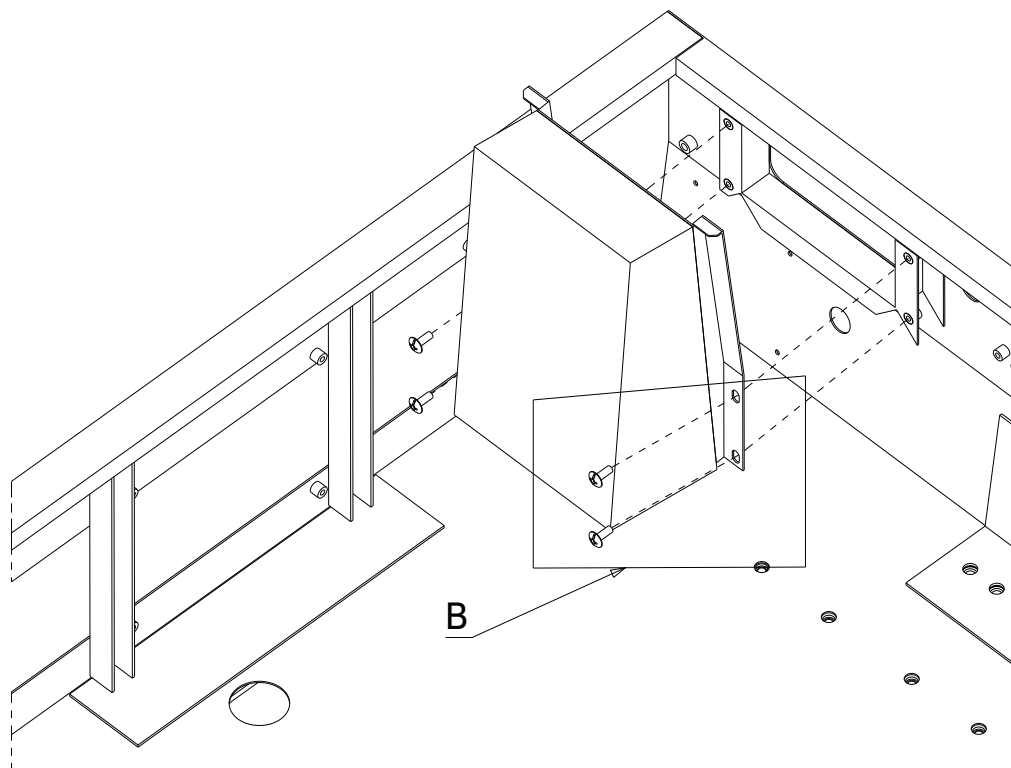

Detail B

Detail A

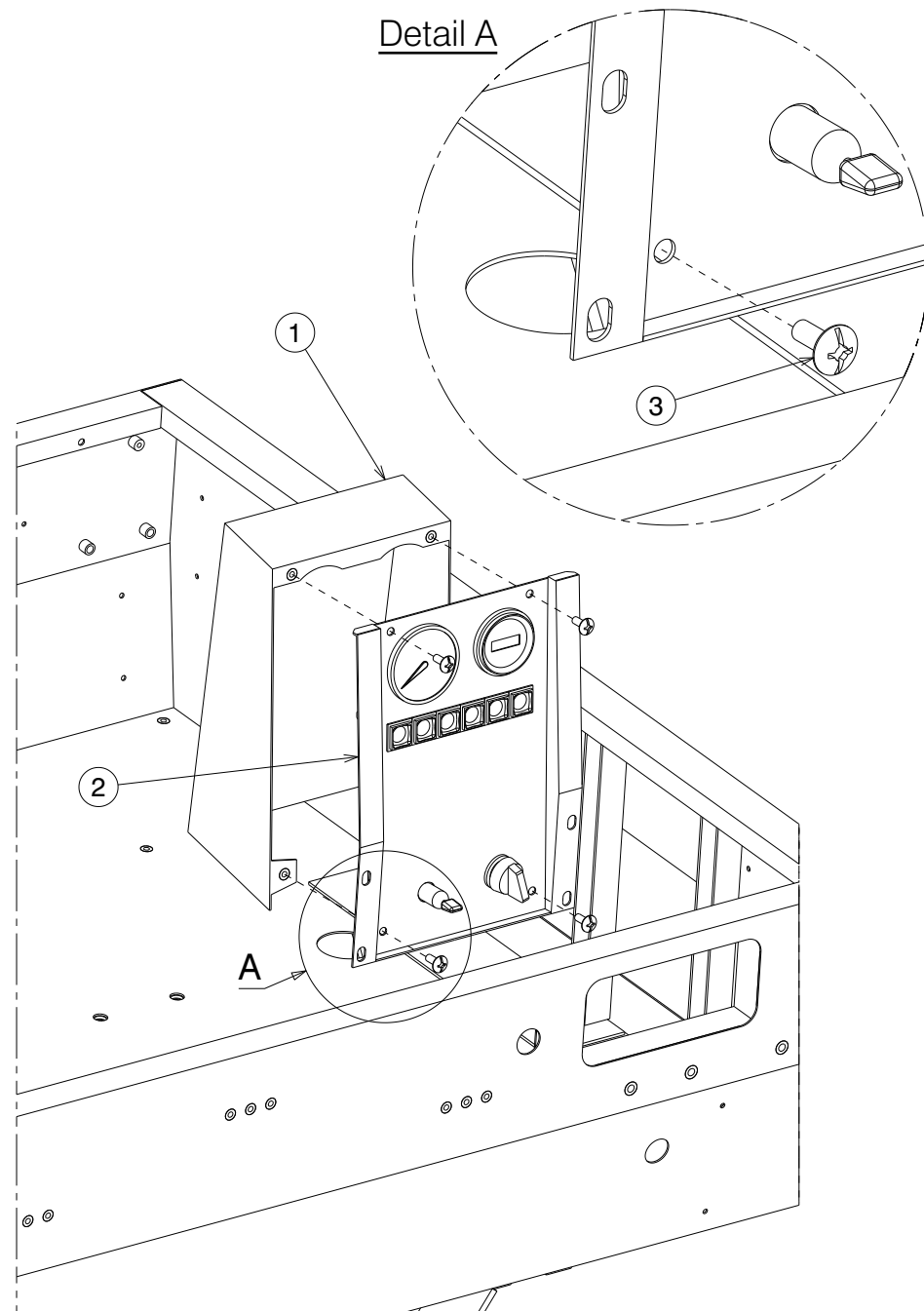



PARTS LIST

Motocompressor – D90 KA

PARTS LEGENDA: Control panel

Tab. 12.0

REF	NAME	CODE	QUANTITY
1	Control panel cover	005-104900-S	1
2	Control panel assembled	024-503105-S	1
3	Recessed raise fillister screw M6x16	243-009-S	8

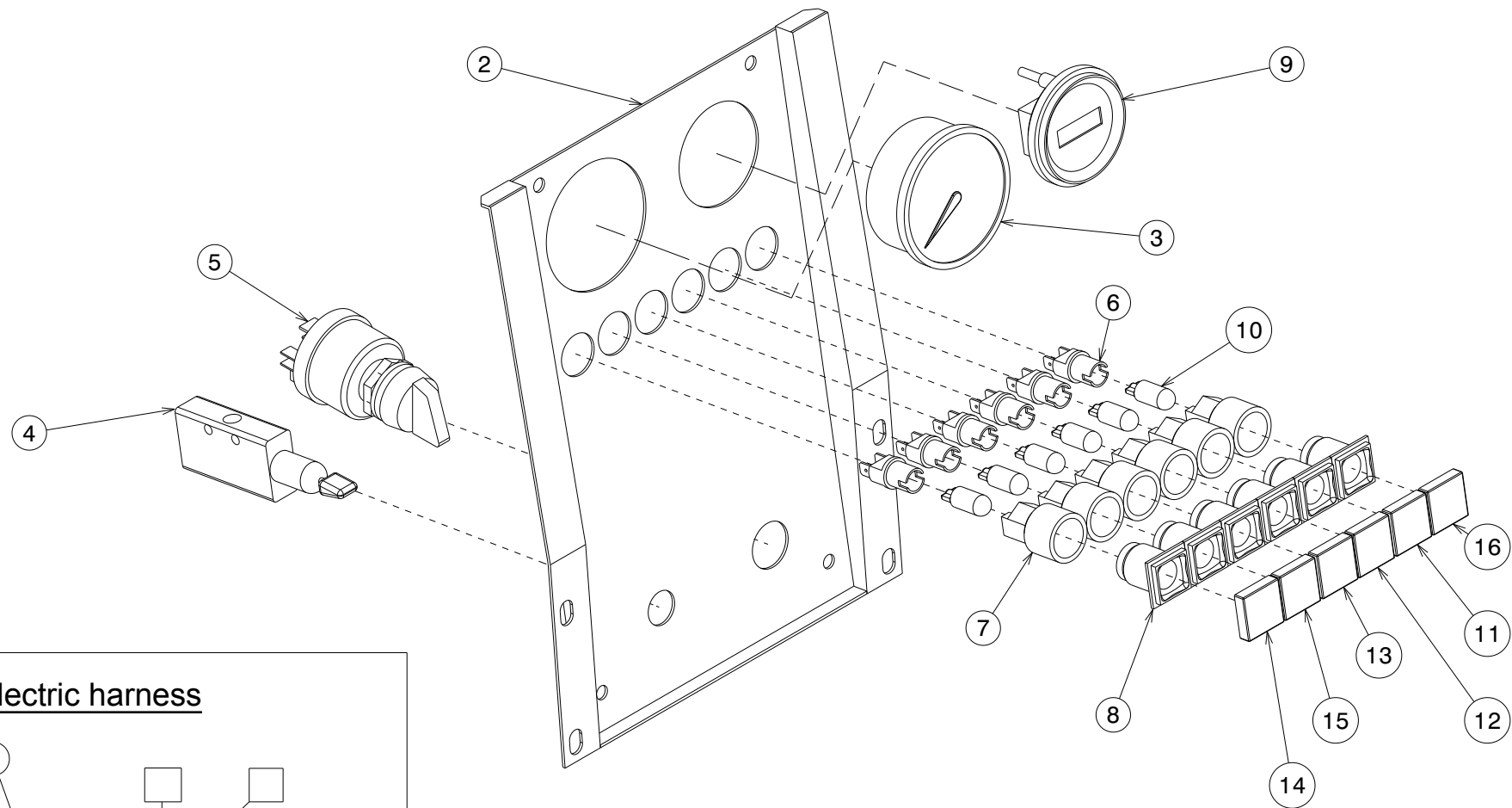

Electric harness

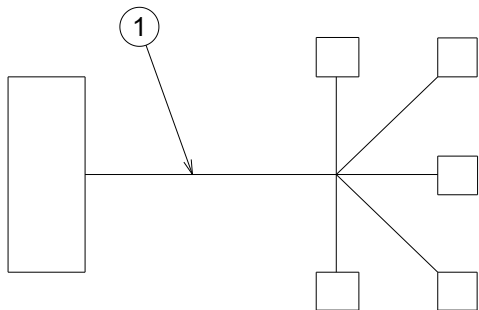



PARTS LIST

Motocompressor – D90 KA

PARTS LEGENDA: Control panel

Tab. 12.1

REF	NAME	CODE	QUANTITY
1	Electrical harness	224-0376-S	1
2	Control panel	040-051500-S	1
3	Air pressure gauge 10 Bar	206-010-S	1
4	Valve for low pressure start-up	033-0292-S	1
5	Ignition switch (with key - up to Serial No.C39489)	274-011-S	1
	Ignition switch (without key)	274-015-S	1
6	Lamp holder	270-010-S	6
7	Front part holder	274-010-S	6
8	Front part	275-010-S	6
9	Electronic hour-counter	180-010-S	1
10	Lamp	275-010-S	6
11	Low pressure oil glass	276-011-S	1
12	Max temp. Water glass	276-015-S	1
13	Battery glass	276-012-S	1
14	Air filter choke glass	276-013-S	1
15	Preheating glass	276-014-S	1
16	Fuel glass	276-018-S	1

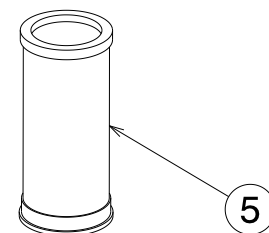
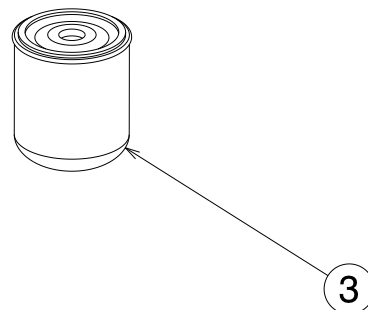
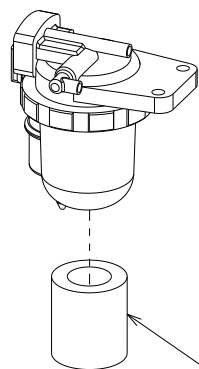
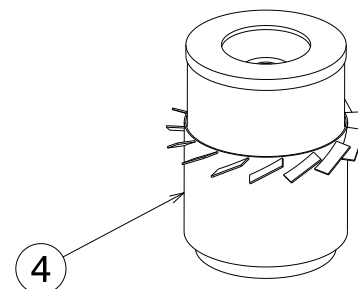
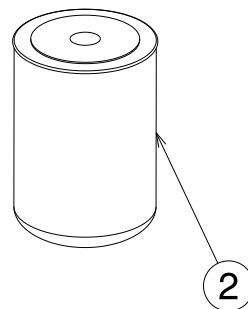
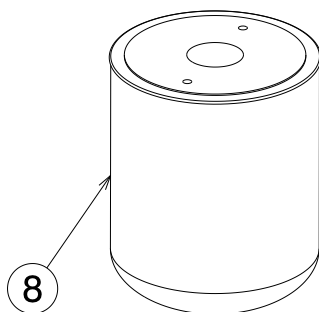
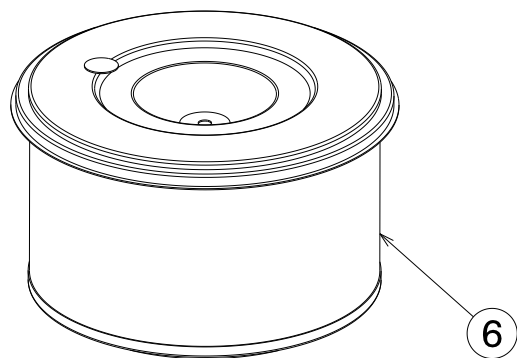



PARTS LIST

Motocompressor – D90 KA

LEGENDA: Filters Kit

Tab. 13

500 working hours filters kit (From Serial No. C38935 + C38741 and C38742)		204-05063-S	
1	Engine gasoil filter	191-0690-S	2
2	Compressor oil filter	099-007-S	1
3	Engine oil filter	099-060-S	2
4	1° engine air filter	162-112-S	1
5	2° engine air filter	162-113-S	1
6	Compressor air filter	162-0075-S	1

2000 working hours filters kit (From Serial No. C38935 + C38741 and C38742)		204-05065-S	
1	Engine gasoil filter	191-0690-S	8
2	Compressor oil filter	099-007-S	4
3	Engine oil filter	099-060-S	8
4	1° engine air filter	162-112-S	4
5	2° engine air filter	162-113-S	4
6	Compressor air filter	162-0075-S	4
7	Separator filter	157-170-S	1

500 working hours filters kit (Up to Serial No. C38934 except C38741 and C38742)		204-1360022-S	
1	Engine gasoil filter	191-070-S	2
2	Compressor oil filter	099-007-S	1
3	Engine oil filter	099-060-S	2
4	1° engine air filter	162-112-S	1
5	2° engine air filter	162-113-S	1
6	Compressor air filter	162-0075-S	1

2000 working hours filters kit (Up to Serial No. C38934 except C38741 and C38742)		204-1360024-S	
1	Engine gasoil filter	191-070-S	8
2	Compressor oil filter	099-007-S	4
3	Engine oil filter	099-060-S	8
4	1° engine air filter	162-112-S	4
5	2° engine air filter	162-113-S	4
6	Compressor air filter	162-0075-S	4
7	Separator filter	157-170-S	1