



**USER'S AND MAINTENANCE
MANUAL**

Date: 09/04/2024

Code MAN D400T4F ENG

Motor compressor D400T4F Dual Pressure

Revision 03



USER'S AND MAINTENANCE MANUAL

MOTOR COMPRESSOR

D 400T4F

Dual pressure 100 psi / 150 psi





**USER'S AND MAINTENANCE
MANUAL**

Date:	09/04/2024
Code	MAN D400T4F ENG
Revision	03

Motor compressor D400T4F Dual Pressure

Dear customer,

Thanks for having purchased this ELGI motor compressor, which is designed and manufactured in compliance with high standards, in order to ensure high quality performance, as well as easy use and installation.

For any information, you can contact our customer service at the following address:

ELGI PORTABLE COMPRESSORS

4610 Entrance Drive St A

Charlotte, NC 28273

704-523-4123

Portableservice@elgi.com

Portablesales@elgi.com



	USER'S AND MAINTENANCE MANUAL	Date:	09/04/2024
		Code	MAN D400T4F ENG
Motor compressor D400T4F Dual Pressure		Revision	03

FOREWORD

These service instructions have been drafted to facilitate the knowledge of the machinery purchased and its modes of use.

In drafting them, we have intentionally omitted the technical in-depth description of some operations linked to the motor and the axle, since such information is contained in the user's and maintenance of the respective manufacturers.

The service instructions contain indications of utter importance concerning the safe appropriate and cost-effective operation of the machine.

The compliance with said operations helps prevent potentially hazardous situations, additional costs and loss of time, increasing at the same time its life-span.

The service instructions and safety measures reported in this manual must be complied with by the user of the machinery.

Besides the service instructions and the accident prevention prescriptions which apply in the countries and places of installation, all the more general rules of safety at the workplace must be complied with.

It is therefore recommended to carefully read the instructions reported in this manual.

This manual cannot be disclosed, duplicated or copied without the previous authorization by the Manufacturer.

Any lack of compliance with the above shall be pursued under the Law, in particular if the illicit action involves advantage for competing companies.





**USER'S AND MAINTENANCE
MANUAL**

Date:	09/04/2024
Code	MAN D400T4F ENG
Revision	03

Motor compressor D400T4F Dual Pressure

TABLE OF CONTENTS

1	General.....	7
1.1	Definitions	7
1.1.1	Qualified personnel	7
1.1.2	Hazard	7
1.1.3	Hazardous area	7
1.1.4	Exposed person	7
1.1.5	Operator	7
1.1.6	Risk.....	7
1.1.7	Guard	7
1.1.8	Protection Equipment.....	7
1.1.9	Expected use.....	7
1.1.10	Reasonably expectable incorrect use	7
1.1.11	Component.....	7
1.1.12	Control Device.....	7
1.1.13	Safety interlock.....	8
1.1.14	Manufacturer	8
1.2	Machinery Identification	8
1.3	Harmonized technical standards.....	9
1.4	General description of the machinery	10
2	Technical features of the machinery	11
2.1	General technical characteristics	11
2.2	Technical characteristics of the compressor.....	11
2.3	Technical characteristics of the engine.....	12
2.4	Technical characteristics of the electric battery	12
2.5	Service temperatures	12
3	Symbols and warnings.....	13
3.1	Hazards.....	13
3.2	Forbiddances	14
3.3	Obligations and notices.....	15
3.4	General notices.....	15
4	Use of the machinery	17
4.1	Use allowed.....	17
4.2	Use not allowed	17
4.3	Residual risk.....	18
5	Levels and qualifications of the personnel.....	19
6	Safety provisions	19
6.1	Safety provisions concerning transport.....	19
6.2	Safety provisions concerning lifting	20
6.3	Safety provisions relevant to towing (for road-certified compressors only)	21
6.4	Safety provisions concerning maintenance	22
7	Machinery components.....	23





**USER'S AND MAINTENANCE
MANUAL**

Date:	09/04/2024
Code	MAN D400T4F ENG
Revision	03

Motor compressor D400T4F Dual Pressure

7.1	Chassis	23
7.2	Body	23
7.3	Engine	23
7.4	Compression unit	23
7.5	Separator tank	24
7.6	Bell and flexible coupling	24
7.7	Control panel.....	24
8	Electrical equipment of the machinery.....	25
8.1	Control instrumentation and devices	25
8.2	Operator's control panel and wiring diagram	25
8.3	Fuses	28
8.4	Lights (for road-certified version)	29
9	Oleopneumatic and pneumatic system.....	31
9.1	Compressor lubrication system.....	31
9.2	Pneumatic system.....	32
10	Provisions for the appropriate utilization of the motor compressor.....	34
10.1	Before starting-up	34
10.2	Start-up	36
10.3	During the work cycle.....	37
10.4	Dual pressure switch (Dual pressure Version Only).....	37
10.5	Stop.....	38
10.6	After stopping the machine	38
11	Monitoring and testing of the machine.....	39
11.1	Monitoring and testing of engine speed.....	39
11.2	Monitoring and control of the air pressure of the compressor	39
11.3	Monitoring and control of air pressure minimum compressor.....	41
12	Safety device	42
12.1	Verification of the safety valve	42
13	Maintenance	43
13.1	Routine maintenance	43
13.2	Maintenance program	44
13.3	Values of tightening screws and bolts	46
13.4	Maintenance.....	47
13.4.1	Checking and cleaning the air filters (intake valve).....	47
13.4.2	Control the electrical battery.....	48
13.4.3	Fuso replacement.....	49
13.4.4	Replacement lamps light (for version approved)	49
13.4.5	Clean the radiator cooler	50
13.4.6	Percentage dosage of cooling liquid	50
13.4.7	Checking and cleaning nozzle oil recovery	51
13.4.8	Drainage of the fuel tank	51
13.4.9	Replacing diesel filter	52





**USER'S AND MAINTENANCE
MANUAL**

Date:	09/04/2024
Code	MAN D400T4F ENG
Revision	03

Motor compressor D400T4F Dual Pressure

13.4.10	Control of locking wheel bolts.....	52
13.4.11	Oil filter replacement compressor.....	53
13.4.12	Replacement of compressor oil.....	54
13.4.13	Istructions for replacement of the oil separator element	55
13.4.14	Engine control and maintenance	55
14	Spare parts	55
15	Faults and troubleshooting	56
16	Disposal, elimination, disposal of the machine.....	58
16.1	Instructions for dismantling	58
17	Eliminating the machine	58
18	Waste management	59
18.1	Special waste	59
18.2	Toxic and hazardous waste	59
18.3	Temporary storage.....	59
18.4	Features of the containers	59
18.5	Registration requirements.....	59





USER'S AND MAINTENANCE MANUAL

Date:	09/04/2024
Code	MAN D400T4F ENG
Revision	03

Motor compressor D400T4F Dual Pressure

1 GENERAL

1.1 Definitions

The most significant definitions contained in this manual are reported hereinafter

1.1.1 QUALIFIED PERSONNEL

"Qualified personnel" are those personnel who are familiar with the rules for installation, assembly, repair and servicing of the machinery and who are provided with the specified technical qualification, such as e.g.:

Technical training authorizing to operate in compliance with the safety standards as related to the hazards the presence of electric current, pressure circuits, etc. may involve.

Technical background or - in any case - specific training relevant to the user's and maintenance procedures of the machinery in safety conditions.

Training in the basic first-aid activities.

1.1.2 HAZARD

A potential source of injury or damage to health

1.1.3 HAZARDOUS AREA

Any area within and/or in proximity of machinery where the presence of a person constitutes a risk for the health and safety of said person.

1.1.4 EXPOSED PERSON

Any person being fully or partially in a hazardous area

1.1.5 OPERATOR

The person/people charged to install, operate, adjust, clean, repair or move a Machinery or perform its maintenance.

1.1.6 RISK

Combination of the likelihood and severity of an injury or damage to health which may arise in a hazardous situation.

1.1.7 GUARD

Part of the machinery utilized to ensure protection by means of a material barrier.

1.1.8 PROTECTION EQUIPMENT

Device (different from a guard) which reduces the risk, by itself or associated to a guard.

1.1.9 EXPECTED USE

The use of the machinery in compliance with the user's information.

1.1.10 REASONABLY EXPECTABLE INCORRECT USE

The use of the machinery in a different way than the one indicated in the user's instructions, but which may derive from the easily expectable human behaviour.

1.1.11 COMPONENT

A constituent part of the electrical/pneumatic equipment, usually specified by its function, but used in various applications.

1.1.12 CONTROL DEVICE

A device introduced in a control circuit and used to control the operation of the system (e.g. position sensors, manual control switches, relays, electro-magnetic control valves).



	USER'S AND MAINTENANCE MANUAL	Date:	09/04/2024
		Code	MAN D400T4F ENG
Motor compressor D400T4F Dual Pressure		Revision	03

1.1.13 SAFETY INTERLOCK

Mechanical, electrical or other device whose purpose is to prevent the parts of the machinery from operating in specified conditions (generally, until the guard is closed)

1.1.14 MANUFACTURER

Physical or legal person who designed and/or develops machinery or partly-completed machinery which is subject of this directive and who is liable for the compliance of the machinery or partly-completed machinery with this directive as related to its marketing with his/her name or brand, or for personal use. In absence of a Manufacturer as defined above, the Manufacturer shall be considered the physical or juridical person who markets or puts into service machinery or partly-completed machinery.

1.2 Machinery Identification

The identification nameplate is attached on the motor compressor chassis.

Such nameplate reports the Manufacturer's data, the denomination of the machinery, the code and year of manufacturing.

For any requests for spare parts or actions by our technicians, please refer to the data reported in the nameplate; in particular the code number of the machinery must always be mentioned.

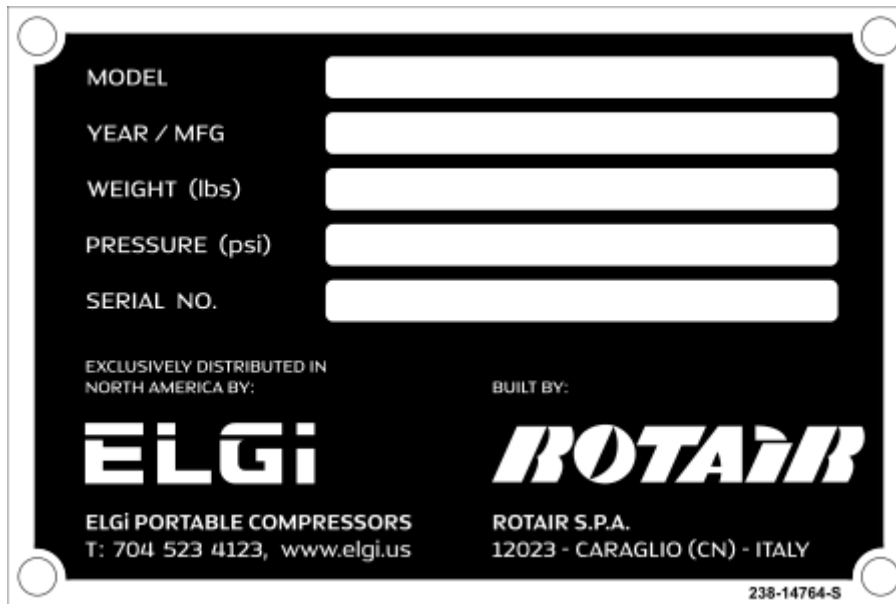

Figure 1.2-1 Identification nameplate D400T4F – Dual Pressure



1.3 Harmonized technical standards

The machinery has been designed and developed in compliance with the provisions contained in the technical standards reported herein under:

UNI EN ISO 12100	Safety of machinery -General design principles - Risk assessment and risk reduction.
UNI EN ISO 13857	Safety of machinery– Safety distances to prevent from reaching the hazardous areas with the upper or lower limbs.
UNI EN ISO 13850	Safety of machinery - Emergency stop system, functional aspects
CEI EN 62061	Safety of machinery - Functional safety of the programmable electrical and electronic control systems as related to safety
CEI EN 60204-1	Safety of machinery - Electrical equipment of the machineries. Part I: General rules.

UNI EN 983	Safety of machinery. Safety requirements relevant to systems and related components for hydraulic and pneumatic transmission. Pneumatics.
UNI EN 349	Safety of machinery - Minimum openings to prevent the crushing of parts of the human body.
D. LGS. January 27th 2010 no.17	Implementation of Directive 2006/42/CE relevant to machinery, which modifies directive 95/16/CE relevant to elevators.
UNI EN ISO 14121-1	Safety of machinery - Risk assessment. General principles
UNI EN ISO -TR 14121-2	Safety of machinery - Examples

**Machine directive 2006/42/CE.****Article 7. Presumption of conformity and harmonized standards**

1. The Member States deem that the machinery provided with the “CE” marking and accompanied by the CE declaration of conformity, whose elements are provided for in Annex II, Part 1, Section A, comply with the provisions of this directive.
2. The machinery manufactured in compliance with an authorized standard, whose reference has been published on the Official Journal of the European Union is assumed to be compliant with the essential health and safety requirements covered by such harmonized standard.
3. The Commission published the references of the harmonized standards in the Official Journal of the European Union.
4. The Member States shall take the appropriate measures to allow the social partners influencing - at national level - the development and control process of the harmonized standards.



USER'S AND MAINTENANCE MANUAL

Date:	09/04/2024
Code	MAN D400T4F ENG
Revision	03

Motor compressor D400T4F Dual Pressure

1.4 General description of the machinery

The machinery described in this manual is motor compressor D400T4F Dual Pressure.

The motor compressor is a piece of machinery with the capacity of generating a given quantity of compressed air in l/m by using a diesel engine as primary energy.

The pneumatic energy finds applications in different fields of use, where "pneumatic" operation tools, accessories and equipment are utilized. For instance: demolition hammers, drilling hammers, vibrators, drilling machines, rammers, coating machines, etc.

Each of these tools/-accessories has its own consumption of compressed air, expressed in liters per minute.

The optimum coupling between the compressor and the tool is achieved when the compressed air consumption does not exceed 85% of the air generated by the compressor (furthermore, it must be taken into consideration that the quantity of compressed air required by the tool shall increase in time, proportionally to the wear of the tool itself).

The correct compressor-tool coupling ratio allows the machinery operating in optimum conditions, as appropriate to ensure long life-span at the highest performance.

An oversized tool - besides creating unfavourable conditions for the appropriate operation of the machinery - shall not develop full performance, since it cannot resort to the required quantity of compressed air.

This machinery has been designed to work at ambient temperature ranging from -10°C/14°F and +40°C/125°F.



2 TECHNICAL FEATURES OF THE MACHINERY

The general technical characteristics of the machinery are reported hereinafter.

2.1 General technical characteristics

DESCRIPTION	D400T4F – Dual Pressure	
	TECHNICAL VALUES AND DATA	
Length (body)	107 “	
Width	54 “	
Height	56 “	
Dry weight	3858 lbs	
Length w/o Bumper/Valves	98 “	
Compression system	Screw single-stage	

2.2 Technical characteristics of the compressor

DESCRIPTION	D400T4F – Dual Pressure	
	TECHNICAL VALUES AND DATA	
Service pressure	100 Psi	150 Psi
Minimum pressure	80 Psi	
Max. pressure	123 Psi	166 Psi
Rated payload at service pressure	400 CFM	
Cooling typology	Specific oil for screw compressors (*)	
Hydraulic system capacity	5.3 gal	
Separator tank capacity	11.35 gal	

(*) For the recommended oil see Paragraph 13.4.12





USER'S AND MAINTENANCE MANUAL

Date:	09/04/2024
Code	MAN D400T4F ENG
Revision	03

Motor compressor D400T4F Dual Pressure

2.3 Technical characteristics of the engine

D400T4F – Dual Pressure	
DESCRIPTION	TECHNICAL VALUES AND DATA
Engine brand	Cummins
Type	QSF 3.8
Number of cylinders	4
Fuel	Diesel
Cooling	By liquid
Power available	130Hp at 2200 rpm
Max. rotation speed	2200 r.p.m.
Min. rotation speed	1400 r.p.m.
Emissions	Interim Tier 4/ Stage IV
Engine oil tank capacity	3,7 gal
Fuel tank capacity	52.8 gal
AVG fuel usage	4.05 GPH @ 60%

2.4 Technical characteristics of the electric battery

D400T4F – Dual Pressure	
DESCRIPTION	TECHNICAL VALUES AND DATA
Rated voltage	12 Vdc
Capacity	70 Ah
Discharge current	400 A

2.5 Service temperatures

D400T4F – Dual Pressure	
DESCRIPTION	TECHNICAL VALUES AND DATA
Minimum ambient temperature limit	14°F
Maximum ambient temperature limit	125°F
Humidity limits	≤ 50% (at 104°F)
Altitude	4.921 feet above sea level



3 SYMBOLS AND WARNINGS

The pictograms and main warning for the operators are reported herein under and indicated by the following denominations and symbols:

3.1 Hazards

**WARNING**

The pictogram calls the attention of specific provisions in order to prevent damage.

**WARNING FOR ELECTRICAL HAZARD**

The pictogram calls the attention of specific provisions in order to prevent damage.

**WARNING FOR CRUSHING HAZARD**

The pictogram calls the attention on a likely hazardous situation with risk of crushing the upper limbs.

**WARNING HAZARD OF ORGANS IN MOTION**

The pictogram calls the attention to the hazard of organs in motion.

**WARNING ON RISK OF SCALDING OR HAZARD DUE TO HIGH-TEMPERATURE ELEMENTS**

The pictogram calls the attention on the hazard of high-temperature elements and risk of scalding.



**WARNING:
OVERHANG
ING LOADS**

OVERHANGING LOAD WARNING

The pictogram calls the attention to the hazard due to the presence of overhanging loads

**WARNING OF THE PRESENCE OF PRESSURE VESSELS**

The pictogram calls the attention to the presence of pressure vessels.

Date:	09/04/2024
Code	MAN D400T4F ENG
Revision	03

Motor compressor D400T4F Dual Pressure**3.2 Forbiddances****FORBIDDANCE TO REMOVE THE PROTECTION EQUIPMENT AND THE GUARDS**

The pictogram calls the attention on the forbiddance to remove protection equipment such as fixed, movable, interlock guards or to tamper with photocells or photocell barriers.

**FORBIDDANCE TO PERFORM CLEANING OR MAINTENANCE WHEN THE MACHINERY IS IN MOTION**

The pictogram calls the attention on the forbiddance to perform cleaning or maintenance operations with organs in motion.

**FORBIDDANCE TO TRANSIT UNDER OVERHANGING LOADS**

The pictogram calls the attention on the forbiddance to transit under overhanging loads.

**FORBIDDANCE TO START THE MACHINERY WHEN THE HOOD IS OPEN**

Date:	09/04/2024
Code	MAN D400T4F ENG
Revision	03

Motor compressor D400T4F Dual Pressure**3.3 Obligations and notices****NOTICES**

This symbol recommends to consult the manual before undertaking a given action.

**OBLIGATIONS TO USE THE PPE (PERSONAL PROTECTION EQUIPMENT)**

The pictogram calls the attention on the obligation to use the personal protection equipment.

**NOTICES**

This symbol highlights that the description involves significant parts, since they may cause severe mechanical and electrical damage and malfunctions if the relevant standards are not complied with. It is recommended to comply with the information contained in this manual and with the law provisions in force as related to health and safety at the workplace.

**HIGHLIGHTING OF THE HOOKING POINT TO LIFT THE MACHINERY.****OBLIGATION TO USE THE SUPPORT FOOT, THE PARK BRAKE AND WHEEL LOCKING WEDGES.****3.4 General notices**

This manual includes the user's and routine maintenance instructions of the machinery. Whenever it is not specified otherwise, the operational and maintenance actions are to be considered as "specialized", i.e. they can only be performed by a technician appointed to the purpose.

Before undertaking any operation on the machinery, carefully read this manual.

ELGI declines any responsibility for any operation performed in conflict with the contents of this document.

Before utilizing the machinery, carefully read this document and comply with the safety law, regulations and standards in force.

This manual and the annexed documents must be considered as an integral part of the machinery they refer to and must always accompany the machinery, even if the latter is transferred to another user. It is therefore appropriate to preserve them for further reference.

This manual and the annexed documents are specific for the machinery they have been drafted for.



Do NOT utilize this manual and the annexed documents to run operations on similar machinery, of the same brand or typology.



USER'S AND MAINTENANCE MANUAL

Date:	09/04/2024
Code	MAN D400T4F ENG
Revision	03

Motor compressor D400T4F Dual Pressure

ELGI is available to its Customer for any further information. Please report the information (type of machinery, model and code) contained in the machinery identification nameplate. All the specific data not indicated in the text are mentioned in chapter "Technical characteristics of the Machinery" as well as in the technical annexes of this user's and maintenance manual.

This manual thoroughly describes:

- The information relevant to towing, lifting and parking of the machinery;
- The general rules and recommendations useful for routine and extraordinary maintenance;
- The modalities to identify and order the spare parts.

Remark: the instructions for the appropriate use of the engine are described in the manual drafted by the engine manufacturer.

This manual must be preserved with care, in its folder, far from sources of humidity, heat and sun rays, so that it can be consulted at any time by both the personnel appointed to the use and by those who need to perform routine and extraordinary maintenance.

This machinery has been exclusively designed and manufactured to deliver compressed air in the conditions stated by the Manufacturer. Every other utilization not mentioned in the "expected uses" shall relieve the manufacturer from any liabilities, which will be at full charge of the user.

"Approved purpose" assumes compliance with the provisions reported hereinafter and related to the appropriate use and maintenance, as well as to the transport of the unit.

All the accident prevention regulations and standards in force need to be complied with as well, besides complying with the general rules in terms of safety and occupational medicine which are governed by the legislation in force.

The manufacturer declines any responsibility in case of changes made on the machinery without its authorization.

Before commissioning, the buyer must ascertain that ANY equipment or machinery, components and protection installations that are not part of the supply of this machinery comply with Machine Directive 2006/42/CE and to the other applicable European Directives (2006/95/CE - 2004/108/CE, etc.).



Date:	09/04/2024
Code	MAN D400T4F ENG
Revision	03

Motor compressor D400T4F Dual Pressure**4 USE OF THE MACHINERY****4.1 Use allowed**

The machinery described in this manual is motor compressor D400T4F Dual Pressure.

The machinery is allocated to work outdoor.

The motor compressor is a piece of machinery with the capacity of generating a given quantity of compressed air in CFM by using a diesel engine as primary energy.

The pneumatic energy finds applications in different fields of use, where "pneumatic" operation tools, accessories and equipment are utilized. For instance: demolition hammers, drilling hammers, vibrators, drilling machines, rammers, coating machines, etc.

Each of these tools/-accessories has its own consumption of compressed air, expressed in litres per minute.

The optimum coupling between the compressor and the tool is achieved when the compressed air consumption does not exceed 85% of the air generated by the compressor (furthermore, it must be taken into consideration that the quantity of compressed air required by the tool shall increase in time, proportionally to the wear of the tool itself).

The correct compressor-tool coupling ratio allows the machinery operating in optimum conditions, as appropriate to ensure long life-span at the highest performance.

An oversized tool - besides creating unfavourable conditions for the appropriate operation of the machinery - shall not develop full performance, since it cannot resort to the required quantity of compressed air.

This machinery has been designed to work at ambient temperature ranging from 14°F and 105°F.



WARNING: *It must be highlighted that the compressed air generated by this unit may contain some very fine traces of oil, therefore it is not appropriate to be utilized with those systems that call for fully oil-free air (e.g.: food processing and pharmaceutical industry, transports of flours and powders, cement, etc...).*

4.2 Use not allowed

It is not allowed to use the machinery for other processes than those which are mentioned in the section above. ELGI declines any responsibility as related to injuries or accidents due to lack of compliance with the specific provisions for use.

4.3 Residual risk



Avoid standing in front of the compressed air discharges. The direct exposure to the air jet may cause medium severity injuries because of the strength and speed of the compressed air.



The machine must operate outdoor, because of the presence of the engine and of the relevant exhaust gases.



It is strictly forbidden to operate the machine in indoor environments whose atmosphere is made of vapours or mixtures of corrosive or explosive gases.

When performing demolition, drilling, sandblasting activities or any other operation that generates dust the tool needs to be connected to the compressor through a pressure-resistant hose of sufficient length to keep the machinery away from the work area, thus preventing the clogging of both the exhaustion filters mounted on the unit and of the radiator for the cooling of the lubrication and cooling liquids. Even in this case, a good operator will locate the machinery leeseid versus the work area.

The machinery has been designed and built to work with the hood/doors closed and - consequently - it is forbidden to keep it open when the engine is on, because - besides generation harmful sound emissions - the required internal ventilation would be interrupted, and this is instead indispensable for the appropriate operation of the compressor.

Make sure that the hood/doors is/are closed.

Even selecting the hoses to connect the machinery to the tool, make sure that they are sized as appropriate, taking into account their length, the volume of air which needs to pass through them and the service pressures: if the hoses show a too small diameter or excessive length, the air flow would interrupt, with subsequent loss of load and poor performance of the tool.

The hoses which convey compressed air to from the machinery to the tool, or to any device applied, is to be provided with a tap located at the end which is connected to the tool; the tap shall be held closed during the connection of the hoses to both the machinery and the tool in order to prevent an inappropriate opening of the tap on board the machine from generating strong flickering of the piping, which may cause injuries. Before disconnecting any hose, make sure there is no pressure inside.

5 LEVELS AND QUALIFICATIONS OF THE PERSONNEL

The actions on the machinery must be performed by qualified, trained and informed personnel only. "Qualified personnel" means people who - based upon their profession - have acquired experience and instructions as well as knowledge on the relevant standards and provisions on accident prevention and operational conditions. Such personnel, appointed by the machinery safety managers, must be able to perform the required operations as well as to recognize and anticipate the potential hazards.



Entrust the activities to appropriately trained or instructed personnel only; determine unmistakably the competences of the personnel as related to the fine tuning and to the maintenance and repair activities.

Define the responsibility of the operators appointed to run the equipment, also through accurate written provisions and authorize them to reject provisions by third parties if in conflict with the safety regulations and standards.

Make sure that the activities are performed by purposely-appointed personnel only.

The actions on the electrical equipment of the machinery can be performed - in compliance with the electro-technical regulations and standards - only by qualified electricians or by people with an appropriate level of competences in the electro-technical field.

The mechanical and pneumatic maintenance can be performed by the operators of the authorized workshops only.

6 SAFETY PROVISIONS

6.1 Safety provisions concerning transport

The motor-compressors which are not certified for towing need to be loaded onto another means of transport. The motor compressor shall have to be attached as appropriate to the floor of the means of transport in order to prevent and unbalancing of the load during transport.

The unit is shipped by ELGI attached to a support appropriate for its handling by means of fork-lift trucks; such wooden platform facilitates the anchorage to the floor of the transport vehicle and prevents the load from sliding. For safe transport, operate as follows:

- 1) Locate the unit near to the cockpit of the transport vehicle.
- 2) Locate the motocompressor as in Figure 6.1-1.
- 3) Make the ropes (A) pass around chassis and tighten them by means of the winches provided with the means of transport.
- 4) Travel at moderate speed.

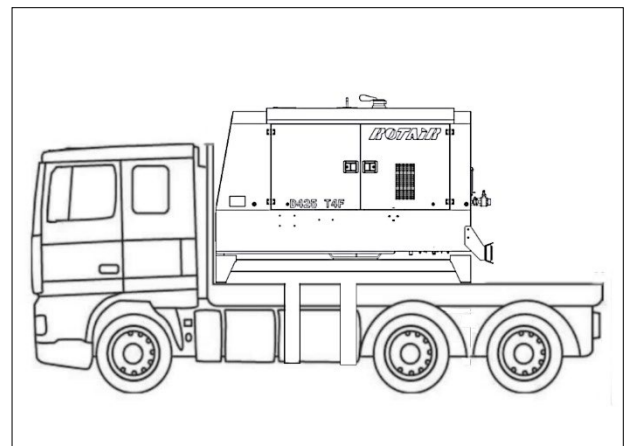

Figure 6.1-1 Instruction for towing in safe conditions

6.2 Safety provisions concerning lifting

A purposely-allocated opening, protected by a rubber membrane, is obtained in the upper panel of the hood and allows for easy access to the lifting hook.

List of the operations for the safe lifting of the machine.

- 1) Make sure that the lifting organ (crane, hoist, etc.) is of the appropriate payload to the weight of the unit and that it is maintained as appropriate.
- 2) In case of lifting installed on truck, use the side anti-tilting stabilizes of the means.
- 3) Attach the hook of the lifting means to the hooking point of the compressor (Figure 6.2-1).
- 4) Lift the unit slowly and without sudden pulls. In the side displacements, prevent the load from swaying excessively.

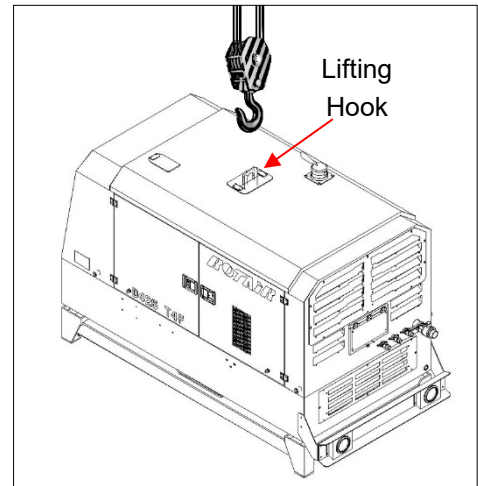

Figure 6.2-1 Lifting system of the



The user must periodically check the efficiency of the lifting equipment and replace it if it results to be no longer appropriate or safe.

No other hooking and lifting systems are allowed except those which are provided with the machine.



This pictogram allows pointing out the hooking system to lift the machine.

- 5) Always check - before handling - that there are no moving parts that may fall. In such case, attach them as appropriate.
- 6) Check the status of ropes and chains before starting the handling operations.
- 7) In any case, always make sure that the machine is solidly fixed to the rope and balanced as appropriate.
- 8) Communicate the start-up of the maneuver as appropriate.
- 9) Never leave the maneuver area with an overhanging load
- 10) Do not stand or transit under the overhanging load.



**WARNING
OVERHANGING
LOADS**



6.3 Safety provisions relevant to towing (for road-certified compressors only)

This paragraph concerns the machinery enabled to road circulation and therefore provided with regular certification.

For the appropriate towing of the motor compressor, comply with the following prescriptions:

- 1) Make sure that the large towing eyebolt or the sphere connection is compatible with the towing device located on the towing vehicle. Make sure that the vehicle is enabled to tow a weight equal to or greater than the one of the motor compressor you intend to tow.
- 2) Check the pressure of the tires.
- 3) Adjust the height of the eyebolt so that it corresponds to the one of the towing vehicle hook; this can be obtained by acting on the articulate joints of the steer, until the towing bar that supports the eyebolt is as horizontal as possible.
- 4) Solidly lock the articulations by means of the appropriate levers, make sure that there is no clearance between the joint teeth.
- 5) Fit the safety plugs.
- 6) Hook the trailer to the vehicle, connecting also the safety cable.
- 7) Release the park brake.
- 8) Lock the foot, or the support wheel, in the highest possible position, making sure that the wheel cannot rotate on itself, and remove the wheel if required.
- 9) Connect the lighting system by introducing the motor compressor plug into the purposely-allocated power outlet located on the vehicle and make sure that all the lights (position, turn, stop, number plate) are operational.
- 10) If the machinery is provided with inertial brake, the latter disengages automatically when maneuvering at reverse speed.
- 11) Periodically check the brakes and - if required - maintain them.

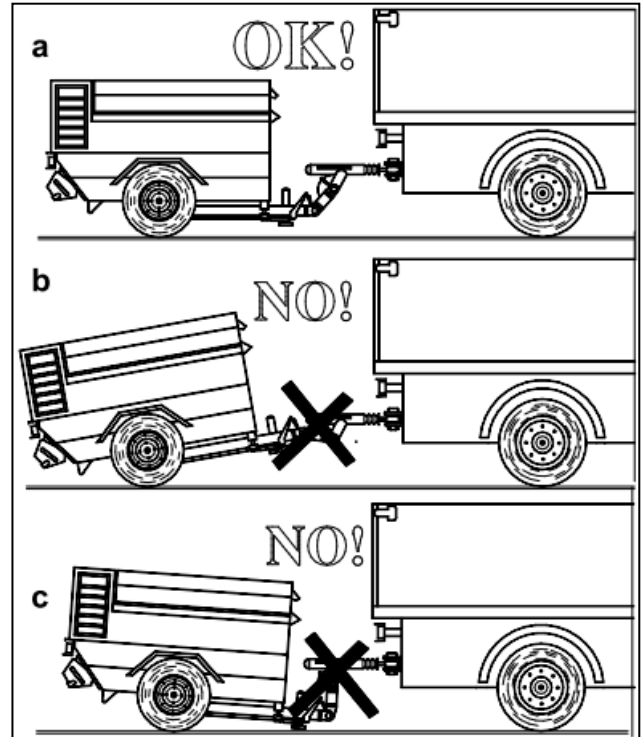

Figure 6.3-1 Instructions for safe towing

For the maintenance of the towing steer, of the axle and for the adjustment of the brakes, refer to the Manufacturer's manual enclosed to this documentation.



WARNING: To know the maximum speed for towing on the road, refer to the standards in force in the country where the towing is performed. On site or in a towing area, do not exceed the towing speed of 10 km/h (6 Mph).



Date:	09/04/2024
Code	MAN D400T4F ENG
Revision	03

Motor compressor D400T4F Dual Pressure

6.4 Safety provisions concerning maintenance

In order to perform the maintenance operations in safety conditions, the following provisions need to be complied with:

- The control and maintenance operations need to be performed by specialized qualified personnel aware of the indications shown in this manual. "Specialized qualified personnel" means people with the appropriate educational background and whose level of skills is appropriate to the kind of intervention and who have acquired experience and instructions on accident prevention and on the procedures required to perform maintenance operations;
- all the maintenance activities need to be performed after a safe stop of the machine and interrupting power supply to the engine;
- if the machinery is stopped during the maintenance and repair operations, it must be protected against accidental restart;
- in case of replacement of parts, the spare parts must be ordered at ELGI's customer service and must correspond to the technical standards defined by ELGI;
- the electrical equipment of the machinery must be periodically inspected. Any component's faults must be immediately pointed out and replaced after careful assessment of their effectiveness and efficiency;
- keep the greatest possible cleanness during the maintenance operations, avoiding using flammable solvents;
- before restarting the machinery after maintenance or overhaul, make sure that all the guards and safety devices are restored and operational.
- never use water to extinguish the flames in case of fire.



After performing the maintenance operations, it is mandatory to restore the protections and - in particular - on the area of the cooling fan moving organs



USER'S AND MAINTENANCE MANUAL

Date:	09/04/2024
Code	MAN D400T4F ENG
Revision	03

Motor compressor D400T4F Dual Pressure

7 MACHINERY COMPONENTS

This unit is a single-phase, silenced oil injection screw mobile motor compressor.

The engine is internal-combustion, fuelled by gas oil, and is connected to the compressor by flexible coupling.

7.1 Chassis

The chassis is made from contoured and electrowelded metal sheet and is of load-bearing type. This chassis undergoes two painting treatments which guarantee corrosion resistance and rust-proofing.

In the chassis there is the control panel which is protected by a transparent polycarbonate lid and which allows the compressed air pressure, the ON/OFF button and the electronic control panel that allows to control all the warnings which will indicate any anomalies of the machine element to which it is connected.

7.2 Body

The body is built entirely out of galvanized sheet iron. It can easily be turned over thanks to a gas hoist and thus allows convenient access to the main machine elements. The whole machine is entirely lined with sound absorbent and fire-retardant material.

Special holes have been created in the elements forming the body, complete with baffles, which allow the cool air necessary for engine and compressor cooling to be sucked in from one side and the heated air to be expelled from the other side. These baffles have been carefully designed in terms of size and shape so as to allow the most efficient internal ventilation of the machine: it is advisable, therefore, to make sure that these openings are kept free and undamaged.

All the parts of the body have been treated with a special painting process which guarantees excellent finishing quality together with maximum impact and rust resistance.

7.3 Engine

The unit is equipped with a Diesel engine whose features are described in Section 2.

As related to the user's and maintenance instructions, refer to the manual provided by the Manufacturer and enclosed to the documentation relevant to this machinery.

7.4 Compression unit

It is completely manufactured in the ELGI factory and consists of a central body (cylinder) inside which are fitted two screw rotors with asymmetric section, a male one with 5 lobes and female one with 6 lobes.

The cylinder is closed at the ends by two head sections which contain the bearings which bear the radial and axial loads created by the air compression. A series of channels, inside the cylinder and heads, undertake to deliver the oil to the various components. The distribution of the lubricant, serves to lubricate the bearings and to maintain a coating of oil between the rotors and the bearings themselves as well as the internal cylinder walls, thereby promoting compression resistance. Another important function of the oil injected between the rotors is that of absorbing the heat generated by the air compression.

The compressed air supplied by this compressor is free of any pulsations and compression comes about axially. A "regulator" unit is mounted on the compression unit, the purpose of which is to regulate the quantity of air taken in according to the amount of air consumed. A double-stage filter mounted on the top of this unit guarantees maximum purity of the suctioned air.





USER'S AND MAINTENANCE MANUAL

Date: 09/04/2024

Code MAN D400T4F ENG

Motor compressor D400T4F Dual Pressure

Revision 03

7.5 Separator tank

Consists of a pressurized container, and due to its construction features respect ASME standards and is supplied with a conformity certificate issued by the manufacturer. The identification and inspection details are impressed on a plate which is welded to the machine.

The lid features the following elements: safety valve for overpressure, a thermal switch which intervenes if the temperature inside the tank exceeds 100°C and valves which regulate the maximum and minimum pressure of the machine.

7.6 Bell and flexible coupling

The engine and the compressor are interconnected by a bell which guarantees concentricity between the engine flywheel and the compressor shaft.

A large-size block joint with rubber pieces interspaced transmits power in a smooth and silent way without splitting.

The engine-compressor thus assembled is clamped to the frame with four flexible supports (silent-blocks) which completely absorb the vibrations it generates. A fan is splined to the engine shaft on the opposite side to the flywheel which generates large air displacement which cools the machine fluids and elements.

7.7 Control panel

The electronic control panel above the air exit cocks is specifically designed so as to have all the controls within reach of a single person all the necessary instruments to control the unit are displayed on the control panel.



8 ELECTRICAL EQUIPMENT OF THE MACHINERY



WARNING: any action on the electrical system must be performed by qualified personnel.

8.1 Control instrumentation and devices

- 1- Manometer
- 2- ON-OFF switch
- 3- MPC-10 Controller
- 4- Start button
- 5- Stop button

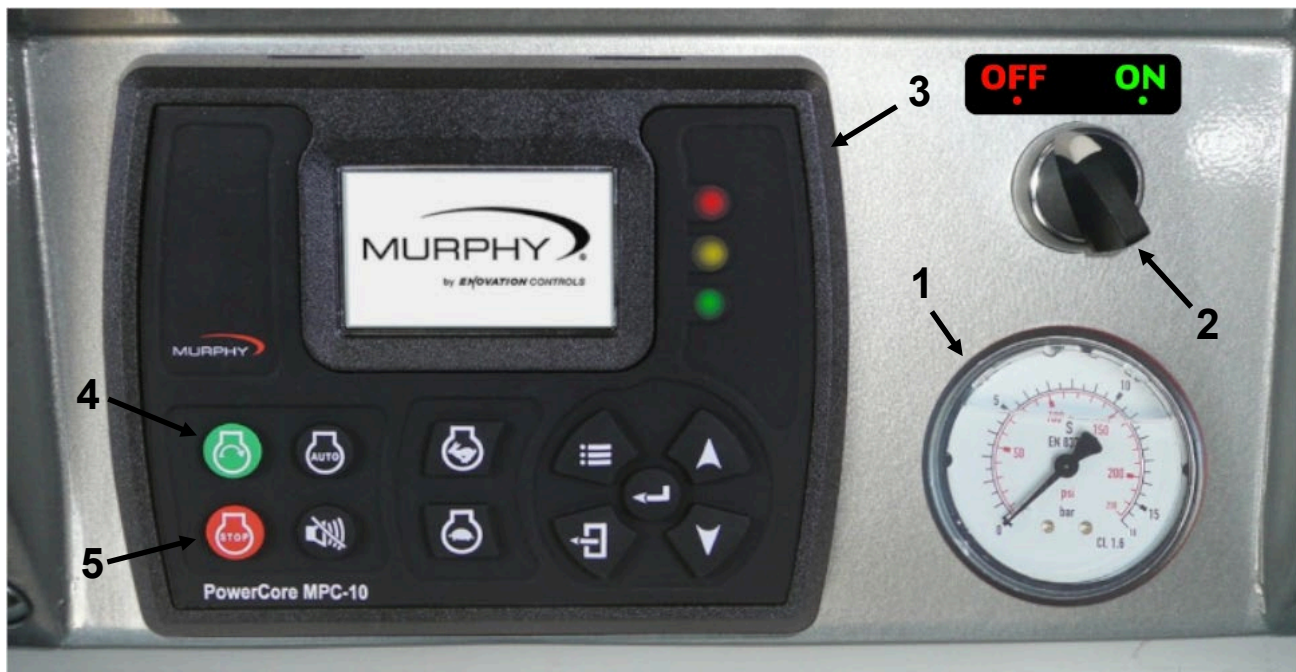

Figure 8.1-1 Instrument panel and control devices

8.2 Operator's control panel and wiring diagram

The buttons have the following functions:

- **On/Off switch** – Turn the selector on the right position to turn on the system.
- **Start Key** – Allows the operator to start sequence in Manual Mode or initiate an auto start sequence when in Auto Mode.
- **Stop Key** – Allows the operator to initiate the stop sequence in either mode of operation. As a safety feature, the stop key will skip the cool-down state when it is pressed twice or held in auto mode. Once shut down, the controller will enter manual mode to eliminate an auto crank condition if the auto start condition is still present.
- **Reset key** – This button allow you to clear any alarms on the display.



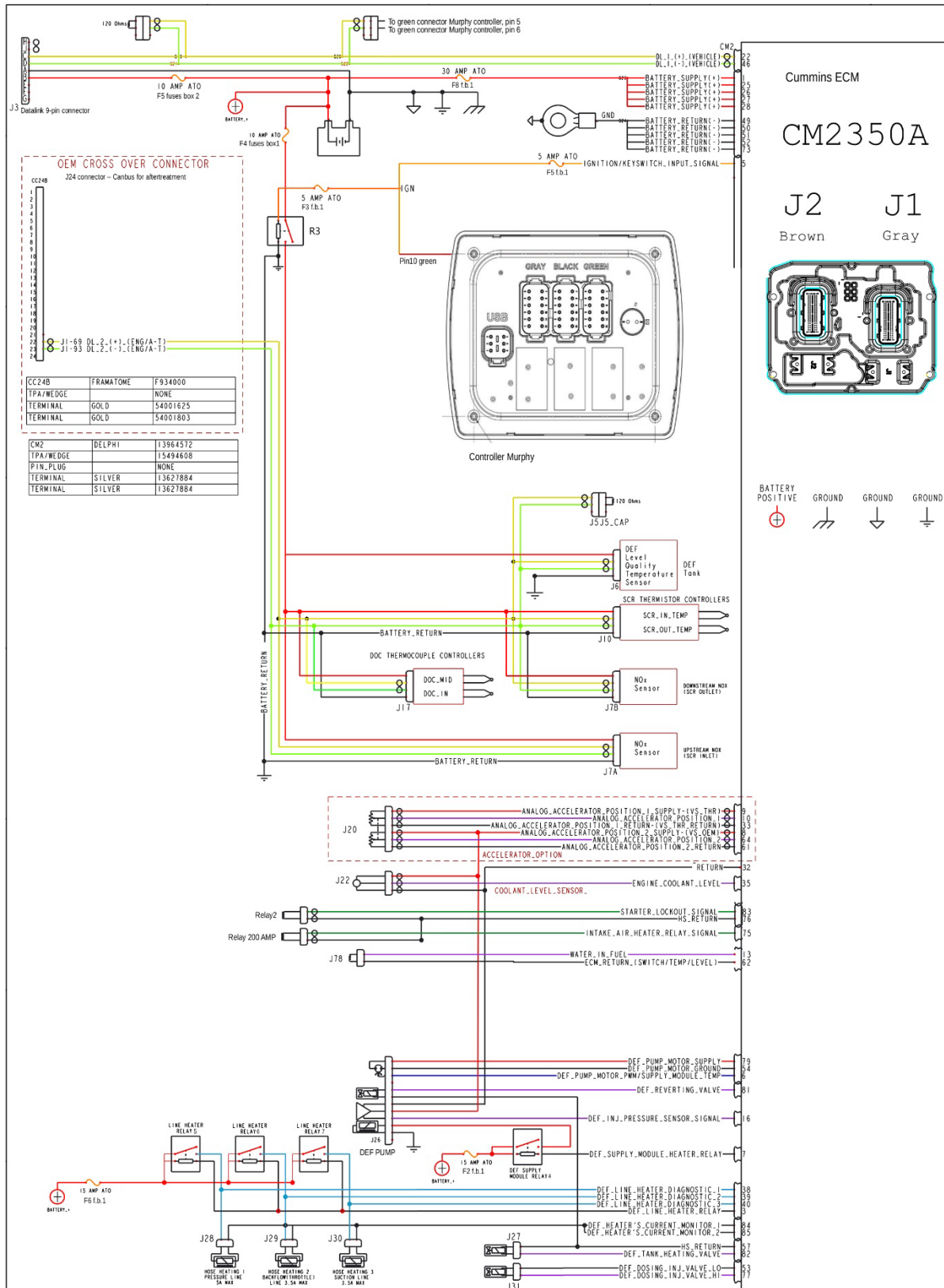

Figure 8.2-1 Wiring system diagram



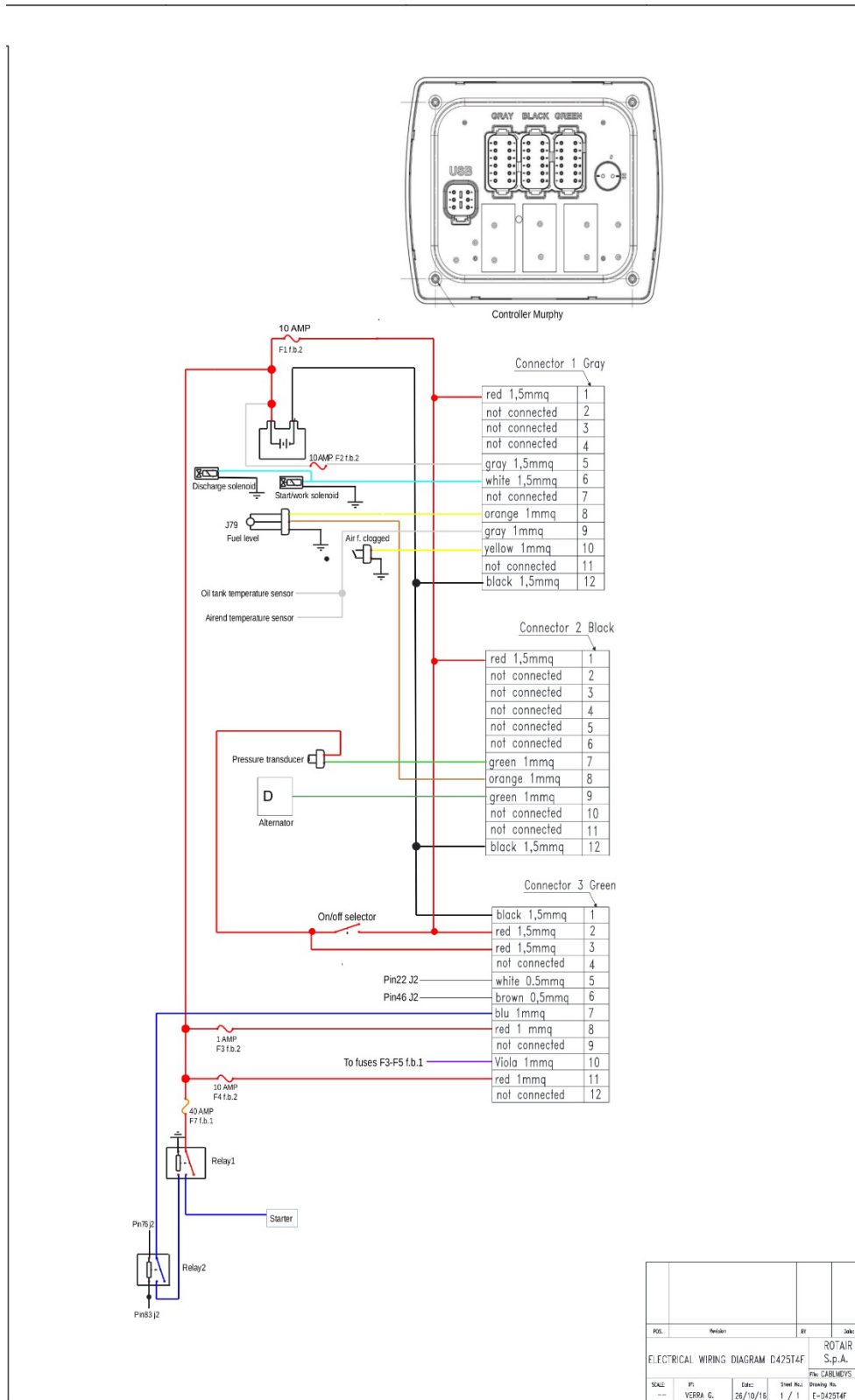

Figure 8.2-2 Wiring system diagram

REV.	Revision	BY	DATE
1			

ELECTRICAL WIRING DIAGRAM D425T4F

SCALE: --- PT: VERRA G. DATE: 26/10/16 SHEET NO: 1 / 1 DRAWING No: E-0425T4F

ROTAR S.p.A.
 P.le GARIBOLDI





	USER'S AND MAINTENANCE MANUAL	Date:	09/04/2024
		Code	MAN D400T4F ENG
Motor compressor D400T4F Dual Pressure		Revision	03

8.3 Fuses

The fuse is an electrical device which can protect a circuit or a device from over current.

The fuse consists of a cartridge provided by a thin lead wire through which the rated current of the circuit/element transits; this wire is the actual fuse, with a precise Amp load. In case of overcurrent, the filament melts and causes the circuit to open.

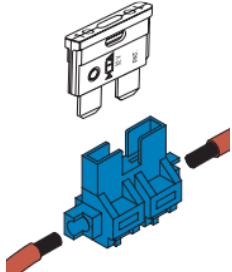

Fuse holder	Fuse drawing	Description	Ampere
		Secondary fuse: device to protect against overcurrent which might damage the fuel solenoid.	15 A



WARNING: *When replacing the fuses, we recommend always utilizing the sale type as indicated in this table and to follow the procedure reported in section 13.4.3 of the manual.*

	USER'S AND MAINTENANCE MANUAL	Date:	09/04/2024
		Code	MAN D400T4F ENG
Motor compressor D400T4F Dual Pressure		Revision	03

8.4 Lights (for road-certified version)



In the road-certified machinery, the electrical system is completed by the light wiring (Figure 8.4-3). The table here in under reports the connections of the wires within the 7-pole outlet and their connection to the rear lighting equipment. This system is directly connected to the towing machine through an extension supplied with the motor compressor.

Rear lights:

- 1) Turn light
- 2) Position and stop light (stop detected by light intensity)

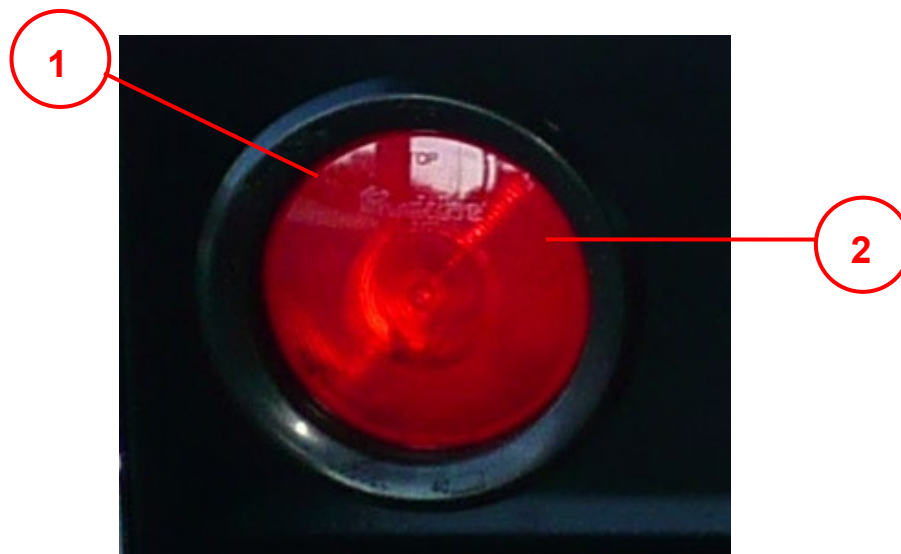
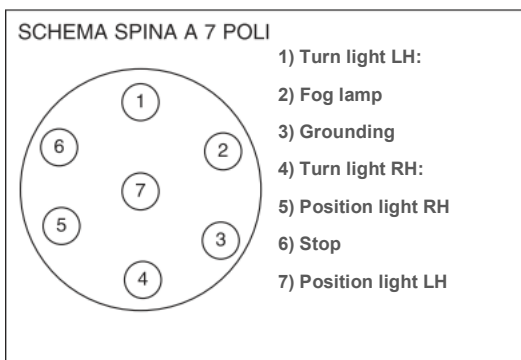

Figure 8.4-1 Rear light



WARNING: To replace the lamps, refer to the Maintenance chapter.



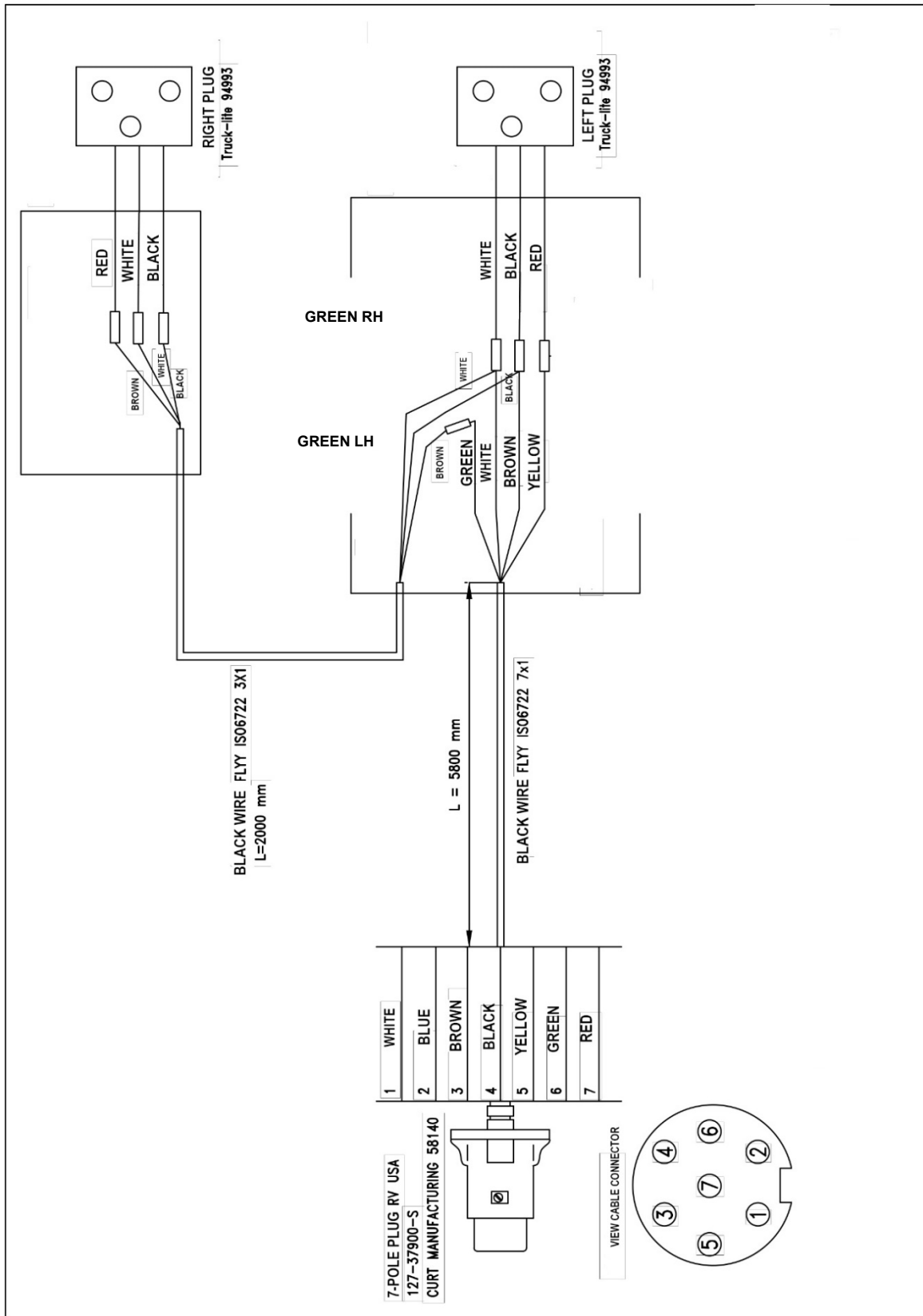

Figure 8.4-3 Light wiring harness



9 OLEOPNEUMATIC AND PNEUMATIC SYSTEM

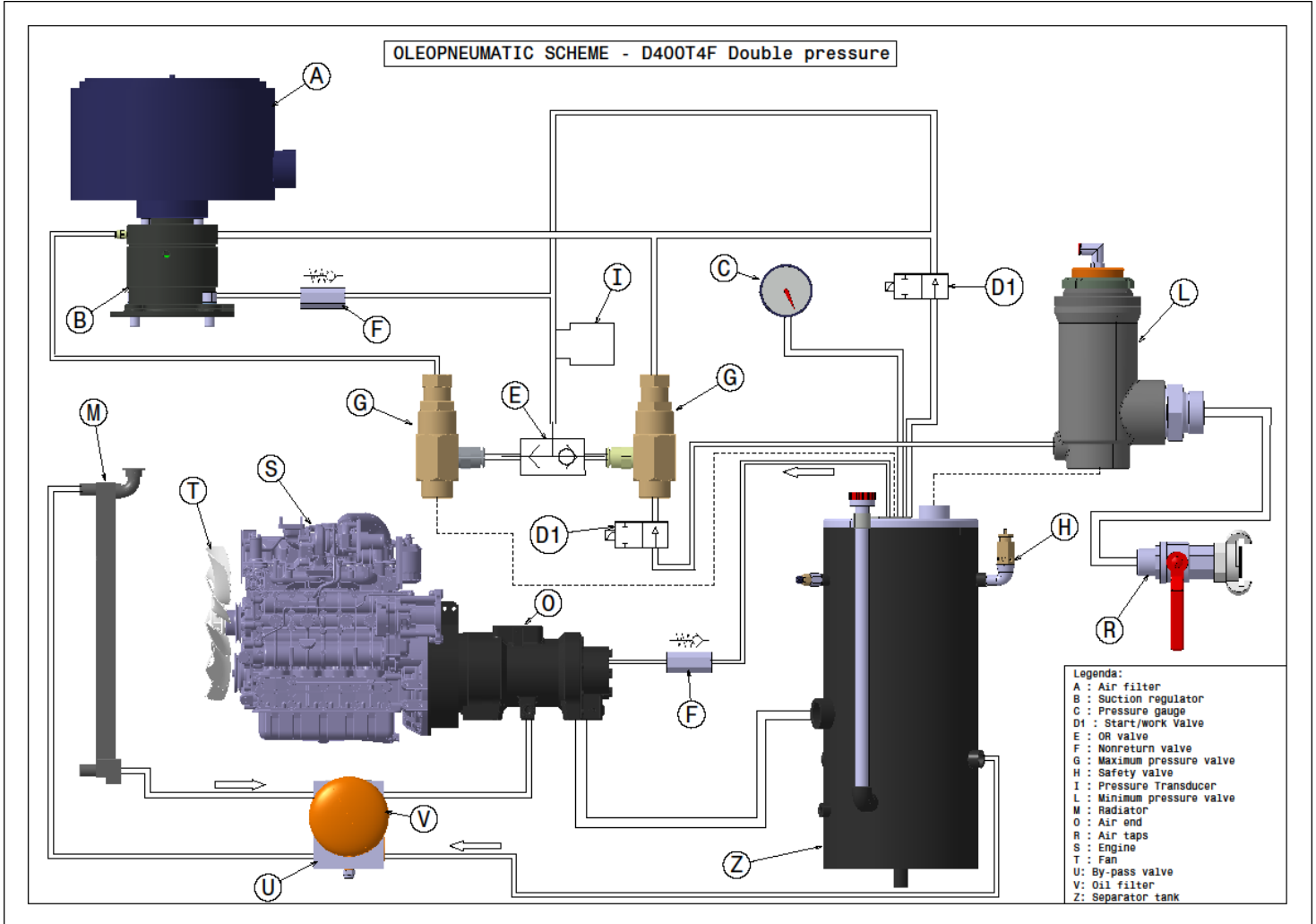

Figure 9-1 Oleopneumatic scheme

9.1 Compressor lubrication system

The hydraulic lubrication system (Figure 9-1) of the compressor consists of:

- Oil separator tank (Z) ;
- Thermostatic valve (U) ;
- Oil filter (V) ;
- Oil cooling radiator (M) ;

The system includes the oil separator tank (Z), the thermostatic valve (U) on which, at the entrance, the oil filter (V) and the oil cooling radiator (M) are mounted.

The lower part of the oil separator tank (Z) acts as an oil tank, will the filtering part is situated at the top which separates the air from the oil.

On starting up the machine, the pressure generated by the compressor, makes the oil inside the tank flow through the conduit in the direction indicated by the arrow. A thermostatic valve (U) is positioned along the route, which according to the actual oil temperature, conveys it all or partially to the cooling radiator (M), more specifically:

- at temperatures of below 65°C, the thermostatic valve remains open and the oil in circulation is directly injected



	USER'S AND MAINTENANCE MANUAL	Date:	09/04/2024
		Code	MAN D400T4F ENG
Motor compressor D400T4F Dual Pressure		Revision	03

into the compressor, without going through the radiator (M).

During the working cycle the oil is heated and when it reaches a temperature of 65°C, the thermostatic valve (U) begins to close, thereby making it necessary for part of the oil to go through the cooling radiator (M).

When the oil temperature reaches 75°C, the thermostatic valve (U) closed completely and from then on all the oil in circulation goes through the radiator and is thereby cooled (M).

From the radiator (M) the oil is injected into the compressor (O).

The filter (V) has an internal "by-pass" valve which permits oil circulation even if it gets blocked. In which case the oil will circulate regularly without being filtered. It is therefore necessary to replace the filter at regular intervals, as indicated in the maintenance programme.

The cooled and filtered oil thereby reaches the compressor (O) and by means of the various internal channels it is distributed to the various parts (rotors, bearings etc) which are thereby cooled and lubricated. From the compressor (o), the oil mixed with compressed air is sent to the tank (Z), inside which the separator (Y) undertakes to separate it from the air.

We have mentioned that the separator filter, inside the separator tank, provides to separate the air from the oil; however a very small quantity is still able to penetrate the inside of the filter, and deposits itself on the low and concave part of the same. It is sucked through the piping on which the calibrated nozzle and the single-direction valve are positioned. The latter impedes the return of oil into the oil separator filter when the machine is stopped.



WARNING: The filter needs therefore to be replaced at regular intervals, as specified in the maintenance program.

9.2 Pneumatic system

The pneumatic system (Figure 9-1) includes:

- Suction filter (A) ;
- Suction regulator (B) ;
- Compressor (O) ;
- Tank (Z) ;
- Minimum pressure and non-return valve (L) ;
- Taps (R) ;
- Maximum pressure valve (G) ;
- Discharge solenoid valve (D2).

The system includes: the suction filter (A), the suction regulator (B), compressor (O), tank (Z) and the oil separator element, the minimum pressure and non-return valve (L), the cock (R) and the maximum pressure valve (G), and the discharge solenoid valve (D2).

The suctioned air, after having passed through the double stage filter (A) reaches the suction regulator, followed by the compressor which conveys it, together with the injected oil, into the oil separator tank. Where the air is separated from the oil. This separation process firstly comes about by means of centrifugal spinning and in the second stage with the use of the oil separator filter.

The air which is cleansed of the oil, is conveyed by the minimum pressure valve (L), and only opens when the pressure in the tank reaches the pre-set value. This minimum pressure formed in the tank guarantees oil circulation even when the air discharge taps (R) are in fully open position.

It is however a good idea not to use tools and equipment, which excessively consume compressed air, and which may cause the tank pressure to fall to below 5-5.1 bar.

In fact prolonged working conditions at below 5 bar, may cause compressor overheating, due to insufficient lubrication, and inadequate air and oil separation, resulting in excessive lubricant consumption.



	USER'S AND MAINTENANCE MANUAL	Date:	09/04/2024
		Code	MAN D400T4F ENG
Motor compressor D400T4F Dual Pressure		Revision	03

The solenoid valve (D1), on stopping the machine, opens automatically, gently discharging all the compressed air still inside the system into the atmosphere.

The minimum pressure valve (L) also acts as a single-direction valve, impeding return into the compressed air unit of air coming from channels or tools connected to the machine.



WARNING: *pressure vessel.*

	USER'S AND MAINTENANCE MANUAL	Date:	09/04/2024
		Code	MAN D400T4F ENG
Motor compressor D400T4F Dual Pressure		Revision	03

10 PROVISIONS FOR THE APPROPRIATE UTILIZATION OF THE MOTOR COMPRESSOR

Consult this user's and maintenance manual before starting-up the machinery.

10.1 Before starting-up

Before starting-up the machinery, strictly follow the instructions here in under:

1. Level the planarity of the machine, no incline greater than 15° is allowed;
2. Make sure that the electric wires are connected to the battery terminals; if the connection is to be performed, use the greater care so that the cable coming from the starter motor is connected to the positive pole (+) of the battery and the earthing one is connected to the negative pole (-) of the battery.
3. Check the fuel level in the tank*.
4. Check the level of the engine oil: as related to the types of lubricant and relevant quantities, comply with the prescriptions contained in the engine manufacturer's users and maintenance manual enclosed to the machinery documentation.
5. Check the oil level in the compressor: this operation must be performed not before than five minutes have passed from the time the machinery was stopped, and this to allow the lubricant in circulation to flow completely into the separator tank.
 - a) Before unscrewing the filler plug where the level gauge is attached, make sure that there is no longer pressure in the system. (The pressure gauge shall indicate 0 bar).
 - b) Take off the plug and clean the level gauge.
 - c) Thoroughly screw back the filler plug and then take it off again to verify that the lubricant level is included between the two marks (min. and max. level) engraved on the gauge.
 - d) Top up if required: the level must never exceed the max. mark.
 - e) Exclusively utilize the types of oil recommended in this user's and maintenance manual.



Figure 10.1-1 Checking the oil level in the compressor



	USER'S AND MAINTENANCE MANUAL	Date:	09/04/2024
		Code	MAN D400T4F ENG
Motor compressor D400T4F Dual Pressure		Revision	03



DIESEL

* Only use Diesel fuel for topping up.



Figure 10.1-2 Gas oil tank for Diesel engine

- If the motor compressor is equipped with a liquid-cooling diesel engine, check the level of the cooling liquid contained in the radiator (Figure 10.1-3).

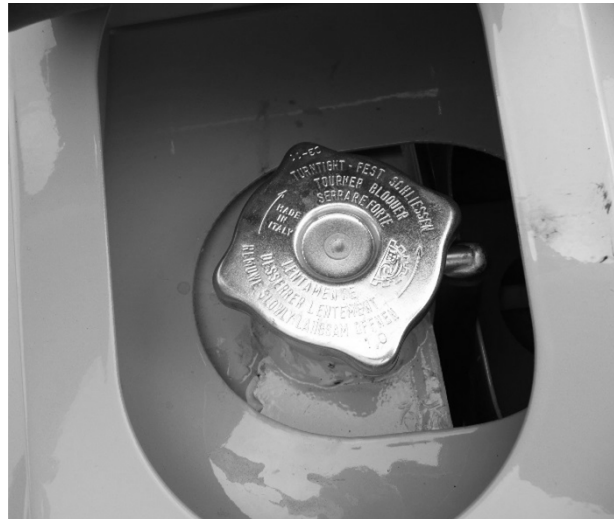



Figure 10.1-3 Checking the radiator cooling liquid

Recommended cooling liquid: ROLOIL ROL-ICE BLU



WARNING: *the radiator plug (Figure 10.1-3) must never be removed when the engine is hot: this would cause a sudden outflow of liquid which might cause severe scalding. Topping up - if required - must be made by means of a blend of water and anti-freeze liquid, in the percentage indicated on the container of the latter.*



	USER'S AND MAINTENANCE MANUAL	Date:	09/04/2024
		Code	MAN D400T4F ENG
Motor compressor D400T4F Dual Pressure		Revision	03

10.2 Start-up

- 1) Fully close the air delivery taps
- 2) ON/OFF Position switch to the right position, which will switch on the spark-plug pre-heating
- 3) Press the green start button key, the engine starts. Should the engine fail to start immediately, do not insist in order to prevent the risk of damage to the starter motor.



WARNING: Do not run any lengthened starts, above 10 seconds.
In case of difficult start-up, repeat the maneuver with short start-ups at intervals.

- 5) Once the engine is engaged, it will run at minimum speed for about 40 seconds; the pressure gauge will indicate a pressure level of between 2-3 bar.
Should one or more of the indicators on the control device still be on after 5-6 seconds, immediately stop the machine to find the cause.
After 40 seconds the motorized compressor will automatically enter working mode: accelerate the engine, open the suction valve and the gauge pressure will reach maximum calibration values
- 6) Then connect the compressed air delivery pipes to the relative tools.
- 7) Gradually open the taps.



WARNING: It is forbidden to open the machinery with the engine hood open.

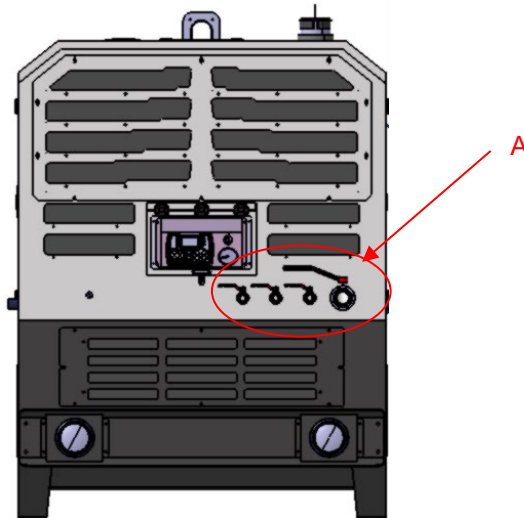



Figure 10.2-1 Location of the taps



WARNING: Do not breathe the compressed air produced by this unit in output from the taps



	USER'S AND MAINTENANCE MANUAL	Date:	09/04/2024
		Code	MAN D400T4F ENG
Motor compressor D400T4F Dual Pressure		Revision	03

10.3 During the work cycle



The machine must always operate with doors closed.

Check the fuel level.

During the work cycle it is necessary to verify that the intake openings are free of foreign bodies such as pieces of paper, plastic, etc ... as these materials can create obstructions to the ventilation system.



Figure 10.3-1 Exhaust pipe



WARNING: *in the vicinity of the exhaust pipe are very hot exhaust gases and harmful. Avoid the stop in the vicinity of the exhaust pipe*

10.4 Dual pressure switch (Dual pressure Version Only)

You can change from 100 to 150 psi at any time so that you can use different tools that work with different pressures.



	USER'S AND MAINTENANCE MANUAL	Date:	09/04/2024
		Code	MAN D400T4F ENG
Motor compressor D400T4F Dual Pressure		Revision	03

10.5 Stop

- 1) Fully close the delivery taps.
- 2) Push the red stop button the motorized compressor will act to de-pressurize the machine until the gauge pressure reaches a value of 3.5 bar before stopping.
- 3) Position On/Off switch to the left position;



WARNING: Engine purging starts at keyswitch OFF and is completed in 100 seconds. Power must be available to the ECM for at least 100 seconds after keyswitch OFF to ensure that purging is completed. During service events, the battery must not be disconnected for at least 100 seconds after keyswitch OFF.



DO NOT DISCONNECT THE BATTERY BEFORE THIS TIME

10.6 After stopping the machine

- 1) If the machine has operated in dusty environments, it will be necessary to clean or replace the air filter and check the status of cleaning the cooling radiator; where this is clogged, it will proceed as indicated in paragraph maintenance.
- 2) Check that during the working phase there are no losses of fuel or lubricating oil inside the machine
- 3) Where possible place the machine away from the elements.



	USER'S AND MAINTENANCE MANUAL	Date:	09/04/2024
		Code	MAN D400T4F ENG
Motor compressor D400T4F Dual Pressure		Revision	03

11 MONITORING AND TESTING OF THE MACHINE

11.1 Monitoring and testing of engine speed



ALL TESTING AND CALIBRATION SYSTEMS MINIMUM AND MAXIMUM, MUST BE DONE BY A PROFESSIONAL, INFORMED, FORMAT AND TRAINED, EQUIPPED WITH A SPECIAL EQUIPMENT TACHYMERIC A STRIKER REFLECTIVE AND EQUIPPED WITH HEADPHONES NOISE.



For all calibrations and adjustments we highlight the following residual risks



Presence of organs of motion. Pay attention to mechanical risks.



The presence of hot surfaces at high temperatures. Pay attention to the risk burn.



11.2 Monitoring and control of the air pressure of the compressor

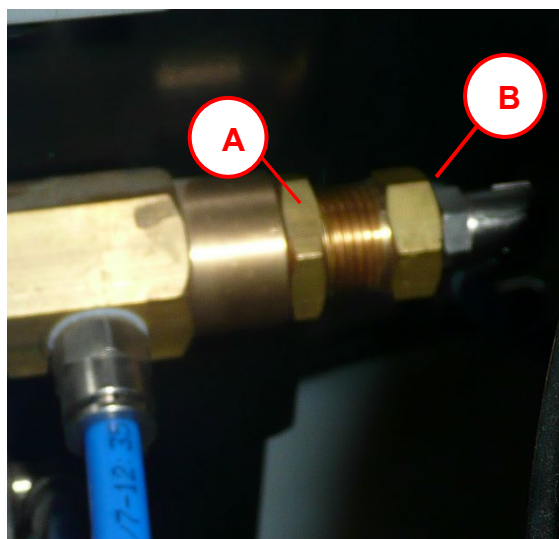



Figure 11.2-1 Adjusting maximum pressure pneumatic circuit

The maximum pneumatic pressure is calibrated during the testing phase of the machine.

If the value of the maximum pressure pneumatic, indicated by the pressure gauge on the control panel, diverged over a $\pm 5\%$ from the value specified in Paragraph 2 of this manual, proceed as follows:

1. Start the machine as described in section 10.2 "Start",
2. Wait for the compressor reaches the maximum pressure and the engine stating the values of idle speed;
3. Close all faucets (Letter A in Figure 11.2 1);
4. Open the bonnet with the compressor in motion;
5. Unscrew with wrench 22 mm in, the nut (Letter A in Figure 11.2 1); Air filter area:
6. If you want to increase the maximum pressure must tighten with 19 mm wrench, nut (Letter B in Figure 11.2 1);
7. If you want to reduce the regime min unscrew, with a 19 mm wrench, nut (Letter B in Figure 11.2 1);
8. Once the adjustment screw, with a 22 mm wrench, nut (Letter A in Figure 11.2 1);
9. Slightly open for 3/4 seconds, the faucet supply air to the engine to accelerate, and then close it. Repeat



	USER'S AND MAINTENANCE MANUAL	Date:	09/04/2024
		Code	MAN D400T4F ENG
Motor compressor D400T4F Dual Pressure		Revision	03

this 2-3 times to allow the settling of the valve.

10. Reading on the pressure gauge located in the control panel, the value of the maximum pressure reached;
11. Compare the measured value with that reported in Paragraph 2, repeat the steps up to the alignment of the two values;
12. Close the doors.



WARNING: *Notice: if the gauge had a discontinuous, jerky, you will have to replace it. So, before making any calibration valve high or low pressure, make sure that the gauge is efficient and reliable.*



11.3 Monitoring and control of air pressure minimum compressor

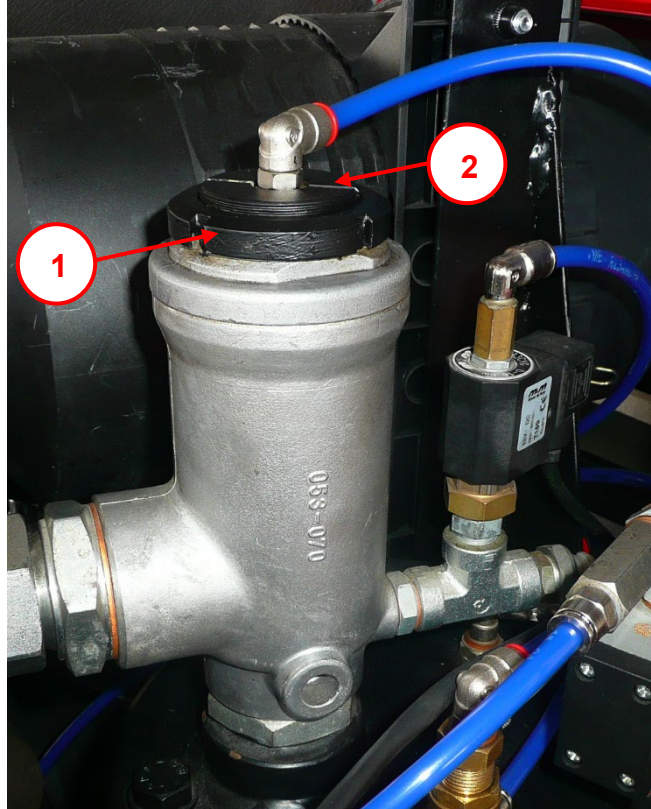

Figure 11.3-1 Adjusting minimum pressure pneumatic circuit

The minimum pneumatic pressure is calibrated during the testing phase of the machine.

If the minimum pressure pneumatic, indicated by the pressure gauge on the control panel, diverged over a \pm 5% from the value specified in Paragraph 2 of this manual, proceed as follows:

1. Start the machine as described in section 10.2 Start.
2. Wait for the compressor reaches the maximum pressure and the engine stating the values of idle speed;
3. Gradually open the air tap (Letter A in Figure 10.2-1);
4. Open the bonnet with the compressor in motion;
5. Release the lock-nut (1).
6. Tighten the regulation screw (2) to increase the pressure to the desired value.
7. Loosen the regulation screw (2) to reduce the pressure to the desired value
8. Tighten the lock nut (1) and close the cocks.
9. Reopen slowly the air tap (Letter A Figure 10.2 1) and close it again repeating the process a few times to allow the settling of the valve;
10. Close the bonnet.



WARNING: *Pressure vessel*



	USER'S AND MAINTENANCE MANUAL	Date:	09/04/2024
		Code	MAN D400T4F ENG
Motor compressor D400T4F Dual Pressure		Revision	03

12 SAFETY DEVICE

12.1 Verification of the safety valve

The safety valve is located on the oil separator tank and starts working to download any accidental overpressure.

The calibration of this valve is performed and verified in the testing of the factory and cannot be varied for any reason or tampered with.

Its efficiency should be checked quarterly by doing the following:

- 1) Start the machine the machine as described in section 10.2 "Start"
- 2) With the valves closed and with the engine at idle speed, using forceps, pick up the pin, as shown in Figure and release it as soon as you have the perception that the valve exhausts air.
- 3) The valve must open sharply with abundant fluid leak and must close sharply once released the lever or reactivated the ring. The maneuver should be brief and not repeated.



Figure 12.1-1 Control of the safety valve



WARNING: *The air escaping from the valve during this operation control is also composed of small particles of oil.*



WARNING: *Pay attention to the danger of projection of liquids.*



If, following the traction using a clamp, the pin is not raised, thus preventing the valve to vent, will require an immediate replacement of the same.



In case of replacement, it is recommended to contact the service ELGI, quoting the serial number of the machine.

The use of a safety valve is not original and does not comply, the ELGI exempt from any liability.



	USER'S AND MAINTENANCE MANUAL	Date:	09/04/2024
		Code	MAN D400T4F ENG
Motor compressor D400T4F Dual Pressure		Revision	03

13 MAINTENANCE



The machine must be subjected to regular periodic maintenance in order to keep unchanged the technical characteristics, and safety originate.

Maintenance work must be performed by qualified personnel of patterns and designs, the machine stopped and power switched off to the electrical panel. Therefore, all maintenance must be carried out only after turning off the machine.



The staff of the service maintenance has to check that they have withdrawn their tools at the end of surgery and before starting the machine again, to avoid damage to the moving parts.

13.1 Routine maintenance

Means with **routine maintenance**, all the maintenance actions that its sole objective was to bring back a system (or one of its components) from a state of failure, the state is working properly before the onset of the problem, without changing or improving the functions performed by the system, nor to increase the value, or improve performance.

In the following chapter are listed in order of frequency, all transactions concerning the compressor part, while as regards the part of the engine, it will be necessary to refer to OPERATING AND MAINTENANCE, which is prepared by the manufacturer of the engine and that is as supplied with the machine.



	USER'S AND MAINTENANCE MANUAL	Date:	09/04/2024
		Code	MAN D400T4F ENG
Motor compressor D400T4F Dual Pressure		Revision	03

13.2 Maintenance program

In this program are listed all the interventions and their frequency to be executed on the various components of the machine. Such interventions are essential for the proper functioning of the machine and its mechanical durability over time.

<i>RECOMMENDED OPERATIONS</i>	<i>FREQUENCY</i>
Checking the oil level compressor	Daily
Check engine oil level (refer to the manufacturer's manual)	Daily
Checking Coolant Level	Daily
Check fuel level and top up (if necessary)	Daily
Check oil or fuel leakage	Daily
Check operation indicator lights	Daily
Check the readability of measuring instruments	Daily
General cleaning operations	Daily
Control of the absence of obstructions to the ventilation system	Daily
Control and clean up the air filter	Every 100 hours
Control and thorough cleaning air filter in dusty	Daily
Check operation lights and license plate lights (only for the approved version of the road)	Daily
Control of the air filter Compressor	weekly
Control of the engine air filter	(Ref. Manual of the engine manufacturer).
Checking the battery electrolyte level	Monthly
Checking tire pressure	Monthly
Checking belt tension Quarterly	Three months
Speed control the minimum and maximum engine	Three months
Control of the efficiency of the safety valve	Three months





**USER'S AND MAINTENANCE
MANUAL**

Date:	09/04/2024
Code	MAN D400T4F ENG
Revision	03

Motor compressor D400T4F Dual Pressure

RECOMMENDED OPERATIONS	FREQUENCY
Cleaning the oil cooler	Three months
Control nozzle oil recovery	Three months
Drainage of the fuel tank	Three months
Replacing diesel pre-filter	Every 500 hours
Control of the efficiency of the braking system	Three months
Control and wheel lock	Three months
Change engine oil	(Ref. Manual of the engine manufacturer).
Oil Filter Replacement compressor	After the first 50 hours
Replacing compressor oil	After the first 50 hours
Control of tightening screws and bolts of the compressor and engine silent-blocks	Every 50 hours
Control of tightening screws and bolts	Every 100 hours
Check tightness of all pipe connections	Every 100 hours
Replace Air Filter Compressor	After 500 hours
Replace oil filter compressor	After 500 hours
Replacing compressor oil	After 1500 hours
Replacing oil separator element	After 2000 hours
Check-up by the service "authorized ELGI".	Every 3000 hours
Control readability nameplate EC Annual	Annual
Control valves from service "authorized ELGI".	Biennial

The ELGI disclaims any responsibility for the failure to comply with maintenance requirements in the table above.





Motor compressor D400T4F Dual Pressure

13.3 Values of tightening screws and bolts

For the correct tightening of screws and bolts on the machine please observe the tightening values corresponding to the class of coupling illustrated in the table below.

We recommend the use of torque wrenches for tightening the screws and bolts on the machine.

Torques not binding N.m (Newton meters)							Couples test sockets for hexagonal screws													
<p>These pairs are reference values for normal metric threads according to DIN ISO 261 and measures supporting heads according to DIN EN ISO 4762, DIN ISO EM 4032, DIN EN ISO 4014 and DIN 931-2, 6912, 7984 and 7990. With these values obtains an exploitation of 90% of the yield strength of the screws, on the basis of a coefficient of friction equal to 0.14 (screw new, untreated, not lubricated). Important: In extreme cases, e.g. screws lubricated with MOS2 and coupling elements cadmium-plated on both sides, the value of torque should be reduced by about 20%.</p>							No. 2, 2A, 2B		No. 4		No. 6, No. 1B, 7, 400		No. 25		No. 26 R No. 626		No. 35 A No. 35 B No. 3112		No. 894 No. 895	
							<p>Tightening values for classes of coupling according to DIN 267</p>							No. 1B, 308, 7		No. 7		No. 7		No. 7
	Tightening values for classes of coupling according to DIN 267																			
	4.6	5.6	6.9	8.8	10.9	12.9														
M 2	0,123	0,162	0,314	0,373	0,520	0,628	4			1,90										
M 2,2	0,196	0,265	0,510	0,598	0,843	1,010	4,5*			2,64										
M 2,5	0,284	0,373	0,726	0,863	1,206	1,451	5			3,55										
M 3	0,441	0,588	1,128	1,344	1,883	2,256	5,5			4,64		14,4				2,32				
M 3,5	0,677	0,902	1,736	2,060	2,893	3,481	6*	17,6	7,4	5,92		17,6				2,96				
M 4	1,000	1,344	2,599	3,040	4,315	5,148	7	25,2	11,4	9,12		25,2				4,56				
M 5	1,916	2,648	5,099	6,031	8,483	10,200	8 9*	34,5 45,4	16,6 23	13,3 18,4		34,5 45,4	34,5 45,4	6,65 9,20						
M 6	3,432	4,511	8,728	10,300	14,710	17,652	10	58,1	31	24,8	58,1	58,1	58,1	12,4						
M 7	5,590	7,453	14,220	17,162	24,517	28,439	11 12	72,7 89,1	40,4 51,5	32,3 41,2	72,7 89,1	72,7 89,1	72,7 89,1	16,1 20,6						
M 8	8,238	10,787	21,575	25,497	35,304	42,168	13 14*	107 128	64,5 79,4	51,6 63,5	107 128	107 128	107 128	25,8 31,7						
M 10	16,67	21,575	42,168	50,014	70,608	85,317	15 16 17	150 175 201	96,2 115 134	77,0 92,3 107	150 175 201	150 175 201	150 175 201	38,5 46,1 53,5						
M 12	28,44	38,246	73,550	87,279	122,60	147,10	18 19* 20*	230 261 294	160 186 215	128 149 172	230 261 294	230 261 294	230 261 294	64,0 74,5 86,0						
M 14	45,11	60,801	116,70	138,30	194,20	235,40	21 22* 23*	330 368 408	247 281 319	198 225 255	330 368 408	330 368 408	330 368 408	99,0 112 127						
M 16	69,63	93,163	178,5	210,80	299,10	357,90	24 25* 26*	451 496 544	359 402 449	287 322 359	451 496 544	451 496 544	451 496 544	143 161 179						



	USER'S AND MAINTENANCE MANUAL	Date:	09/04/2024
		Code	MAN D400T4F ENG
Motor compressor D400T4F Dual Pressure		Revision	03

13.4 Maintenance

13.4.1 CHECKING AND CLEANING THE AIR FILTERS (INTAKE VALVE)

This check should be performed periodically every 100 hours of work;
If the machine operates in a very dusty environment, it will also be necessary on a daily basis.

The filter consists of a filter cartridge.

For cleaning or replacement cartridge, proceed as follows:

- 1) Open the side flaps





Figura 13.4.1-1 Aspiration air filter

- 2) Remove the cartridges.

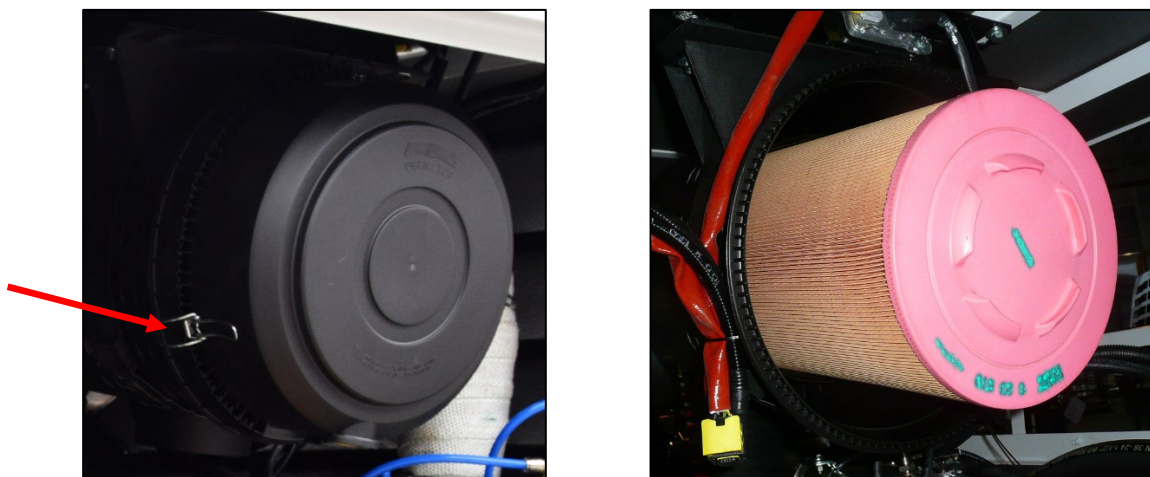

The filter cartridge can be cleaned several times with compressed air.
The filter cartridge must never be washed with water or other substances;
It must, however, be replaced every 500 hours of work.



	USER'S AND MAINTENANCE MANUAL	Date:	09/04/2024
		Code	MAN D400T4F ENG
Motor compressor D400T4F Dual Pressure		Revision	03

13.4.2 CONTROL THE ELECTRICAL BATTERY



Figure 13.4.2-1 Battery compartment



Extended not-use of the machine - battery charge status



- To avoid complete discharge of the battery, if the machine is not to be used for > 3 months, disconnect the negative terminal of the electrical system.
- Periodically check the battery charge and recharge it every 3 months.

Cleaning the terminals

The battery terminals (poles) must be cleaned and greased periodically. The accumulation of dirt can hinder the passage of electric current.

For cleaning it is necessary to switch off the machine, disconnect the terminals starting from the negative terminal and clean the terminals.

Checking the clamps

Generally the negative and positive pole of the battery are greased (eg. Pulp vaseline or similar product) to avoid the oxidation of metals. The paste on the clamps must be periodically replaced.

In the same way, check that the terminals are firmly connected to the battery poles and if necessary tighten them. In fact, it may happen that vibrations loosen the grip of the clamps. A mobile connection can cause malfunctions and even failures to the vehicle's electrical devices.

Checking the battery fluid (in the case of an unsealed battery)

The electrolyte must always reach the covering level of the element plates.

If the battery fluid is low, it may compromise its operation.

In these cases, if the level of covering is below the minimum level it is necessary to have it checked by a qualified electric maintenance technician and if necessary to provide the addition of cold water distilled water to restore the liquid level.

If, despite top-up, the battery continues to discharge frequently, it must be replaced.



CAUTION: Take special care when handling battery fluid. Potentially corrosive liquid.



	USER'S AND MAINTENANCE MANUAL	Date:	09/04/2024
		Code	MAN D400T4F ENG
Motor compressor D400T4F Dual Pressure		Revision	03

13.4.3 FUSO REPLACEMENT

Fuse replacement should be performed when one or both fuses were damaged or not intervene.



To replace the fuse proceed as follows:

- 1) Stop the machine;
- 2) Open the bonnet;
- 3) Open the fuse box;
- 4) Pull the fuse to be replaced with tweezers (to fuse 15 A), and unscrew the screws for the 40 A fuse:
- 5) Once removed the fuse concerned, observe the internal filament, this must be intact to function properly, if this is the case simply up item. If this filament is sectioned into two means this is to be replaced;
- 6) In the event of a damaged fuse replace it by choosing a fuse with identical characteristics. The characteristics of the fuses are described Par.8.3 in this manual;
- 7) After inserting the new fuse in the housing close the fuse box;
- 8) Close the bonnet;
- 9) Now you can restart the machine.



13.4.4 REPLACEMENT LAMPS LIGHT (FOR VERSION APPROVED)

For the replacement of a bulb must procedures as listed below:

- 1) Stop the machine;
- 2) Open the cover of the headlight using a screwdriver to remove the four screws of the lamp
- 3) Unscrew the light bulb;
- 4) Screw in a new bulb taking into account the value of the corresponding power (see table below);
- 5) Close the cover of the headlight using a screwdriver to screw the four screws of the headlights

Headlight composition		
Type of bulb	Power bulb	Number of bulbs
Lamp position, stop *	5/21 W	1
Signal light bulb	21 W	1
License plate lamp and rear fog	21 W	1

* The lamp position/stop double stranded vary its own light intensity depending on the use of the brake



	USER'S AND MAINTENANCE MANUAL	Date:	09/04/2024
		Code	MAN D400T4F ENG
Motor compressor D400T4F Dual Pressure		Revision	03

13.4.5 CLEAN THE RADIATOR COOLER

The coolants of the compressor and the motor are cooled by a radiator which, consequently, must be kept clean so that the ventilation air can pass freely and easily through its fins honeycomb.

A radiator fins clogged with dust or any other bodies, because of the harmful and dangerous overheating to the mechanical screw compressor, greatly jeopardizing the operation and durability. We recommend that you check it periodically and, if necessary, clean it with compressed air or clean it with a jet of water under pressure.

13.4.6 PERCENTAGE DOSAGE OF COOLING LIQUID

To determine the proper amount of antifreeze to be paid within the tank of the radiator must follow the following table:

T (°F)	Total volume of the cooling plant	Water volume	Antifreeze volume	Antifreeze percentage*
°F	gal	gal	gal	%
- 10 / 14	7.1	3.50	3.50	50%

**Cooling liquid suggestions: ROLOIL ROL-ICE BLU*



WARNING: *The radiator cap must never be removed in a warm engine: in this condition would occur a sudden leakage, which could cause serious burns to the person. The possible filling must be done with a mixture of water and antifreeze liquid, in the percentage indicated on the container of the latter.*



13.4.7 CHECKING AND CLEANING NOZZLE OIL RECOVERY

Control and clean the oil recovery is to be performed, should you find a leak of oil mist mixed with air compressed, operating as follows (Figure 13.4.7-1).

- 1) Unscrew the fitting located at the center of the tank (Letter Z in Figure 13.4.7-1);
- 2) Inside the ring (Letter Z in Figure 13.4.7-1) is a nozzle (Letter U in Figure 13.4.7-1): make sure that its calibrated hole is not blocked (blow with compressed air);
- 3) Replace the fitting.



WARNING: During normal operation of the compressor, in the pipe from the fitting transparent part (Z), you will notice a certain amount of oil flow from the said fitting (Z) towards the head of the compressor



Figure 13.4.7-1 Nozzle oil recovery

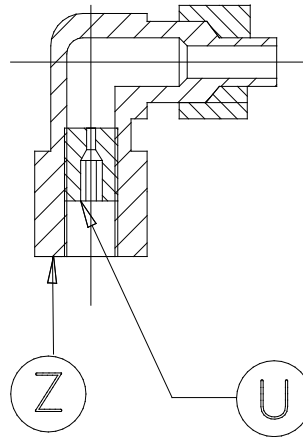

13.4.8 DRAINAGE OF THE FUEL TANK

The draining of the fuel tank has the aim to eliminate the water possibly settled on the bottom of the tank due to the formation of condensation or refilling fuel polluted.

Avoid fuel filling with cans because sometimes, these may contain traces of water which, being heavier than the gas oil, is deposited on the bottom and can build up to reach the level of the dip tube.



Periodically carry out the drains to prevent even small parts of water can be aspirated and injected into the engine.

It is also advisable to carry refuel at the end of the work shift to prevent the temperature range of the tank walls make possible the formation of condensation inside it.

In conjunction with the drainage of the tank, also proceed to the replacement of the fuel filter to eliminate from the fuel every trace of water.



The draining of the tank must be performed at least 30 minutes after stopping the machine, to allow water to separate from the diesel fuel and to settle to the bottom of the tank.

The polluted fuel spilled from the purges should be collected and delivered to specialized centres and authorized the collection and disposal of hazardous waste.



	USER'S AND MAINTENANCE MANUAL	Date:	09/04/2024
		Code	MAN D400T4F ENG
Motor compressor D400T4F Dual Pressure		Revision	03



Remember that the residual fuel should not be totally discarded in the environment.

13.4.9 REPLACING DIESEL FILTER

To replace the fuel filter (Figure 13.4.9-1) proceed as follows:

1. Turn off the machine;
2. Open the door;
3. Bring small pan to contain any spillage of small amounts of gasoil still in the pipeline;
4. Unscrew the filter to be replaced;
5. New filters must be tightened and secured **by hand only**.
6. Close the door;
7. Start up the machine and ensure that there is no leakage near the seal; if there is switch off the machine and check the condition of the filter and that it is correctly positioned in its slot.



Figure 13.4.9-1 Gasoil filter

13.4.10 CONTROL OF LOCKING WHEEL BOLTS

Periodically check the tightness of the wheel bolts using a spanner, avoiding the use of air screwdrivers that may damage the bolt threads.



	USER'S AND MAINTENANCE MANUAL	Date:	09/04/2024
		Code	MAN D400T4F ENG
Motor compressor D400T4F Dual Pressure		Revision	03

13.4.11 OIL FILTER REPLACEMENT COMPRESSOR

For proper filter replacement compressor oil must do the following:

- 1) Stop the machine and open the hood of the engine compartment;
- 2) Use a chain wrench to unscrew the filter to be replaced (Figure 13.4.11-1);
- 3) Oil the seal of the new filter to be tightened and only by hand;
- 4) Start the machine and make sure that there are no oil leaks in the vicinity of the seal, in this case to stop the machine and recheck the status and the correct positioning of the seal in its housing.



Figure 13.4.11-1 Compressor oil filter



WARNING: The filter is impregnated exhausted mineral oil pollution and harmful to the environment, therefore it must be disposed of at specialized centres of collection and treatment of waste.



	USER'S AND MAINTENANCE MANUAL	Date:	09/04/2024
		Code	MAN D400T4F ENG
Motor compressor D400T4F Dual Pressure		Revision	03

13.4.12 REPLACEMENT OF COMPRESSOR OIL

The oil compressor must be performed taking into consideration the working conditions in which the machine operates (dusty, very high temperatures, etc.).

The oil change intervals must never exceed 2.000 hours of work.

In conjunction with the replacement of the oil must be changed the corresponding filter.

RECOMMENDED OIL	QUANTITY	PART NUMBER
AIRLUBE PORTABLE LUBRICANT	2.5 Gallons	512-12-0000
	5 Gallons	512-12-0001
	55 Gallons	512-12-0002
	330 Gallons	512-12-0003



WARNING: It is strictly recommended to use ONLY OIL FOR SCREW COMPRESSORS.
ELGI declines any responsibility if other oils will be used.



Filter life oiler is expected around 2000 hours of work, but is closely related to a careful observance of all maintenance requirements given in this manual.

A quantity of oil or excessively low in the tank, the breach of the frequency of oil changes or the use of the machine with cooling radiator clogged may determine an anticipated and irreparable deterioration of the filters. Therefore, if, after the control and clean the recovery (operation described in the paragraph 13.4.7) and making sure the proper oil level in the tank, you are still traces of oil in the compressed air, is will have to replace the exhaust cleaner.

To ascertain the degree of clogging of the filter separator operate as follows:

- 1) Install a pressure gauge upstream of the separator and make sure that on the machine is efficient.
- 2) Start the machine.
- 3) Partially open the faucet flow until the pressure gauge on the control panel shows the value of the operating pressure.
- 4) Read the value of the pressure gauge located upstream of the oil separator filter and compare two values: if, between the two readings, is a difference of more than 1 bar replace the filter separator

The oil separator filter must never be washed with water.



WARNING: *Pressure vessel*



13.4.13 INSTRUCTIONS FOR REPLACEMENT OF THE OIL SEPARATOR ELEMENT

1. The operation must be undertaken with machine off and no pressure in the oil separator tank.
2. Disconnect all the pipes from the connections positioned on the closure flange of the separator tank, marking them so there is no problem on re-assembly.
3. Loosen the screws (A) and remove the flange (B).
4. Extract the filtering element (D) together with the seals (C) and (E).
5. Assemble the new seal (E) in the relative slot which has been previously cleaned. Endure that a metallic insert has been clipped to the seal in order to avoid the isolation of the filter and the accumulation of static electricity. Otherwise there is a risk of the separator filter catching fire.
6. Insert the new separator element correctly positioning it into the relative slot.
7. Assemble the second seal (C) with the same precautions as above.
8. Reassemble the flange (B) in the pre-assembly position.
9. Tighten the bolts, (A), with a tightening torque of 80 Nm.
10. Re-connect all the pipes to the respective fittings.
11. Start up the machine ensuring there is no leakage between the cap and the tank.
12. Allow the machine to operate for 10-15 minutes with closed cocks
13. Stop the machine with tank depressurized to 0 bar, re-check the screw tightening (A).

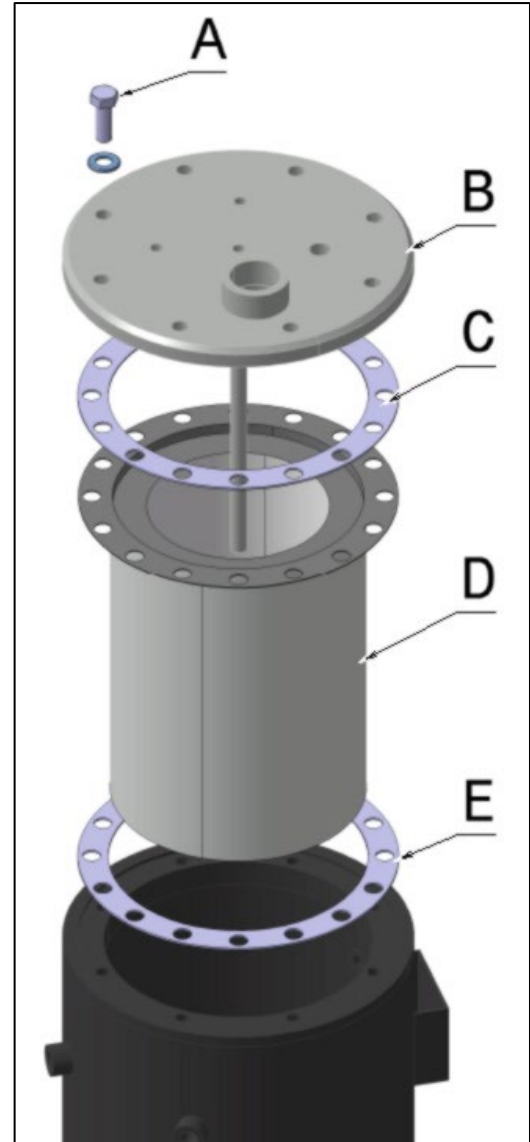
**13.4.14 ENGINE CONTROL AND MAINTENANCE**

As for the controls of the engine and replacing air filters, diesel filter, timing belt, motor oil and other specific controls refer to the owner's manual of the engine manufacturer attached to this documentation.

14 SPARE PARTS

In case of need to order a single component contact your authorized service center ELGI.



15 FAULTS AND TROUBLESHOOTING

Abnormal	Cause	Solution
The engine will not start.	Battery discharged or defective.	Recharge and replace if necessary.
	Terminals of the battery cables oxidized or loose.	Cleaning of the same and their tightening.
	No fuel.	Top up the fuel in the diesel tank.
	Solenoid faulty fuel.	Seek customer service by the manufacturer of the engine.
	Air in the fuel pipe.	Locate the infiltration by careful verification of all pipes.
	Injection pump defective.	Call in Customer Service by the engine manufacturer.
	Temperature sensors defective.	They are located at: - Headed-cylinder engine; - Output air compressor; - Tank separator. One at a time, unplug its power cable from the probes to identify the defective sensor and replace it. The temperature light on the control panel should go off.
Opening the taps the motor does not accelerate.	Starter defective Injectors failures	Call in Customer Service by the engine manufacturer.
	Control valve of maximum pressure defective.	Remove the control valve max and accurately control the spring and the conical seat. If the defect cannot be repaired, the valve must be replaced.
The engine speeds up but no air come out	Minimum pressure control valve blocked.	Disassemble and check that the piston is free to move. Check that the spring is intact. If the defect cannot be repaired the valve must be replaced. Reassemble and adjust the minimum pressure following the instructions in Section 11.3.
	The machine stops suddenly and can only be restarted after a few minutes of waiting.	A temperature sensor detects a temperature anomaly and consequently stops the machine.
If it turned out to be the probe placed on the compressor control the level of 'oil in the tank and if necessary top up; Check the cooling fan and clean the radiator; replace the oil filter of the compressor. If that proves to be positioned on the oil separator tank, check the oil separator filter following the		





**USER'S AND MAINTENANCE
MANUAL**

Date:	09/04/2024
Code	MAN D400T4F ENG
Revision	03

Motor compressor D400T4F Dual Pressure

Abnormal	Cause	Solution
		instructions proceeding to its eventual replacement Par 13.4-13.
Abnormal	Cause	Solution
The engine does not reach the maximum speed of the speed indicated and the compressor does not do.	Engine speed lower than expected.	Have the injection apparatus of the motor by qualified personnel. Replace the fuel filter. Run the draining of the fuel tank (Par. 13.4.9).
	Minimum working pressure too low.	Adjust it according to the instructions of Par. 11.3
Oil leaking from the taps.	Too much oil in the tank.	To the correct level (Par.13.4).
	The machine works in non-horizontal position.	Ensure position the machine level
	Nozzle clogged oil recovery.	See Par. 13.4.7



	USER'S AND MAINTENANCE MANUAL	Date:	09/04/2024
		Code	MAN D400T4F ENG
Motor compressor D400T4F Dual Pressure		Revision	03

16 DISPOSAL, ELIMINATION, DISPOSAL OF THE MACHINE

16.1 Instructions for dismantling

To dismantle the machine safely, proceed as follows:

- 1) Place the machine in a wide and make sure it is turned off.
- 2) Empty the liquid waste in the tanks of motor oil, fuel, coolant, hydraulic oil and store them in special containers. For disposal of these types of waste follow the next paragraph.
- 3) Loosen the screws of the body and remove covers
- 4) Remove all the components of the machine one by one dividing them according to their material composition

The various components of the machine have to be disposed in relation to the type of waste to which they belong.

The following describes the different types of waste that can be generated during the life of the machine:

- Waste motor oil
- Waste hydraulic oil
- Residues of coolant
- Residual fuel
- Liquid remaining battery power
- Rags or paper impregnated with a diluents or other substances used for the cleaning of the various organs of the machine

17 ELIMINATING THE MACHINE

The operations of destruction and disposal must be carried out in a safe condition by a qualified specialist and after carefully reading and incorporated the recommendations and instructions provided in this section of the manual of use and maintenance and consulting the safety data sheets relating to substances in the machine mentioned in the previous chapter..

Once you reach the end of the mechanical life of the compressor, this has to be taken out of service so that it cannot be used for other purposes.



18 WASTE MANAGEMENT



The withdrawal of special waste and / or hazardous should be entrusted with the written contract to authorized firms; and those who physically transport and handling must be in possession of the required authorizations. The hauliers authorized must be enrolled in the relevant register.

18.1 Special waste

They are considered a hazardous waste residue from industrial, agricultural, crafts, commercial and service, for quality or quantity, is declared similar to municipal waste. These include also: machinery, equipment and metal parts of engines deteriorated and obsolete.



18.2 Toxic and hazardous waste



Are considered hazardous toxic waste all waste containing or contaminated by the substances listed in Directives 75/442 / CEE, 76/403 / CEE and 768/319 / CEE or other regulations in the countries of use and installation of the machines.



18.3 Temporary storage



Are considered hazardous toxic waste all waste containing or contaminated by substances listed in Directives 75/442 / CEE, 76/403 / CEE and 768/319 / CEE or other regulations in the countries of use and installation of the machines.

Temporary storage of toxic and hazardous waste is allowed according to the expected disposal of waste by treatment and / or final disposal. In any case, observe the mandatory laws of the country of the user in the field of environmental protection.

18.4 Features of the containers

The fixed and mobile containers, designed to contain toxic and hazardous waste must possess adequate strength requirements in relation to the chemical-physical properties and to its hazardous characteristics of the waste contained. The containers in which products are stored or dangerous or harmful materials must, in order to disclose the nature of their content, carry signs and markings prescribed.



18.5 Registration requirements

In accordance with the EU Directive 75/439 / CEE on the disposal of waste oil, the records of loading / unloading must be kept by all companies that produce hazardous waste or hazardous toxic from industrial and artisanal (in each case the 'Users should refer to the regulations implementing that Directive in the country of installation and use of the machines).

PARTS LIST

Motocompressor

D *400T4F*
- DUAL PRESSURE

D *425T4F*
- STANDARD



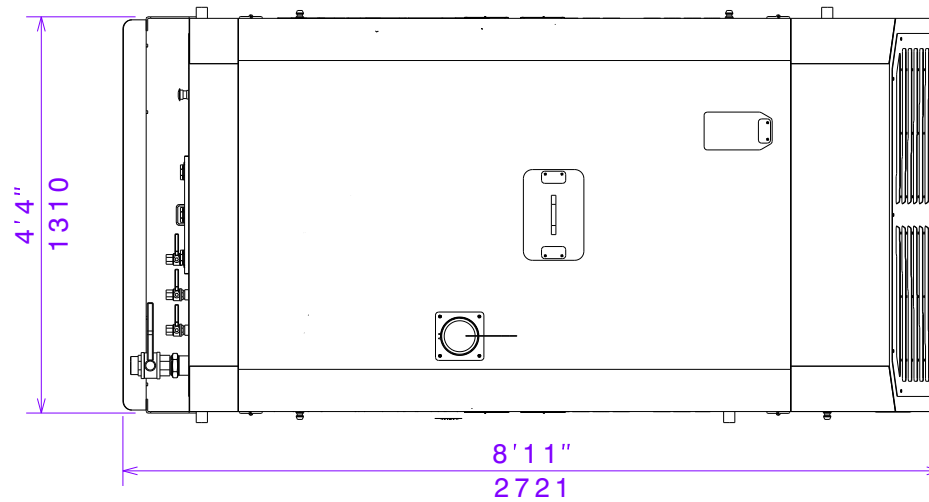
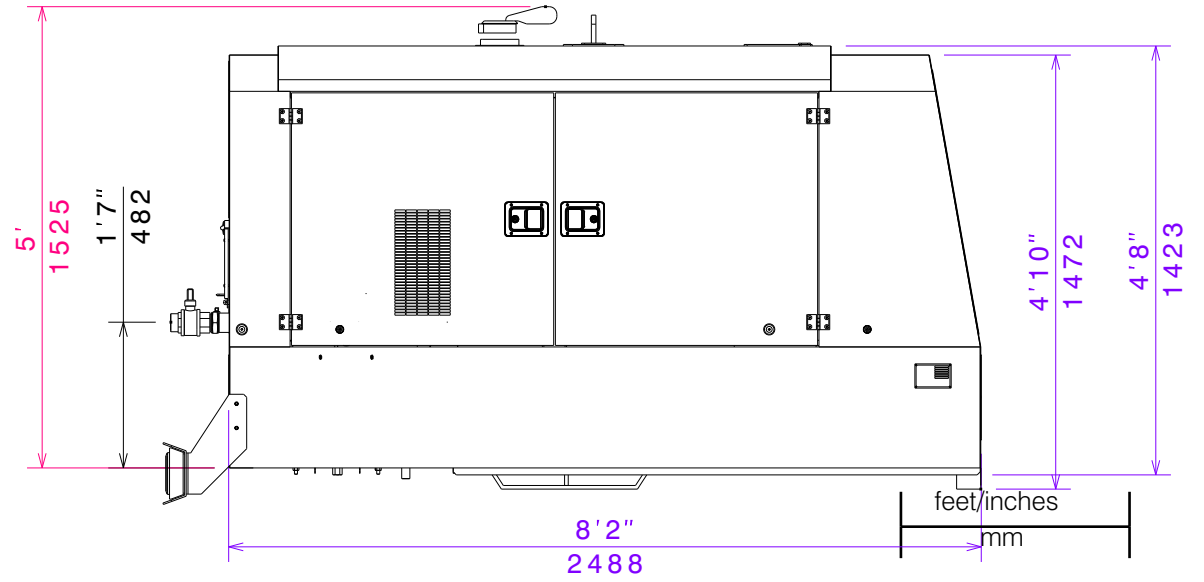
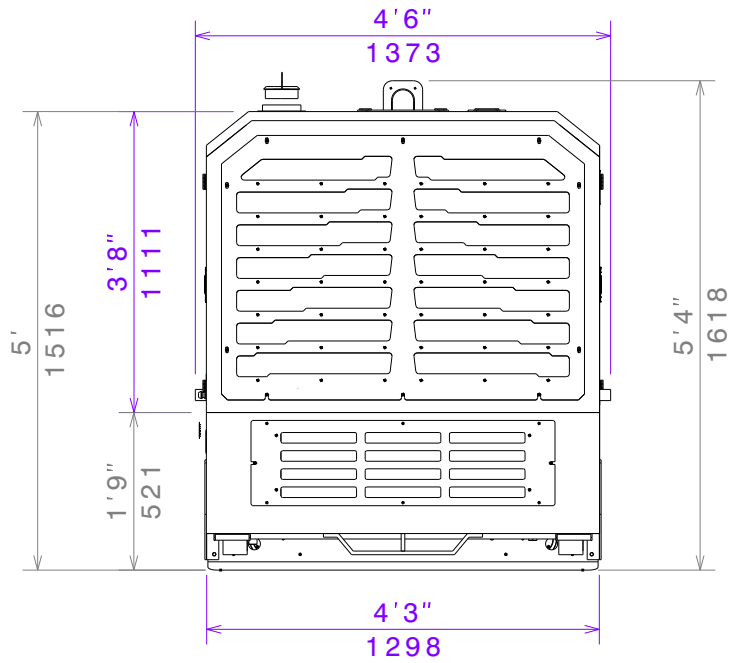



PARTS LIST

Motocompressor – D425 T4F

PARTS LEGENDA: Dimensions

Tab. 01.0

POSITION	DESCRIPTION	PART No.	QUANTITY
-	Standard Chassis	-	-

USA Version

Detail B

Detail F

Detail D

Detail E

Detail A

Detail C

Mudguard support

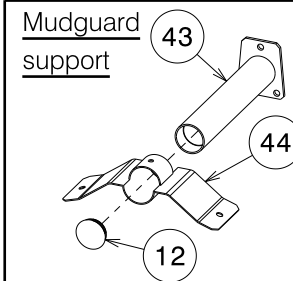
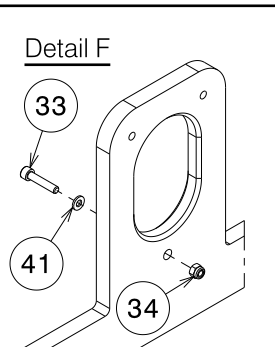
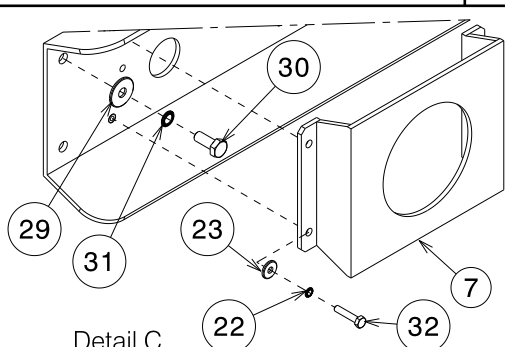
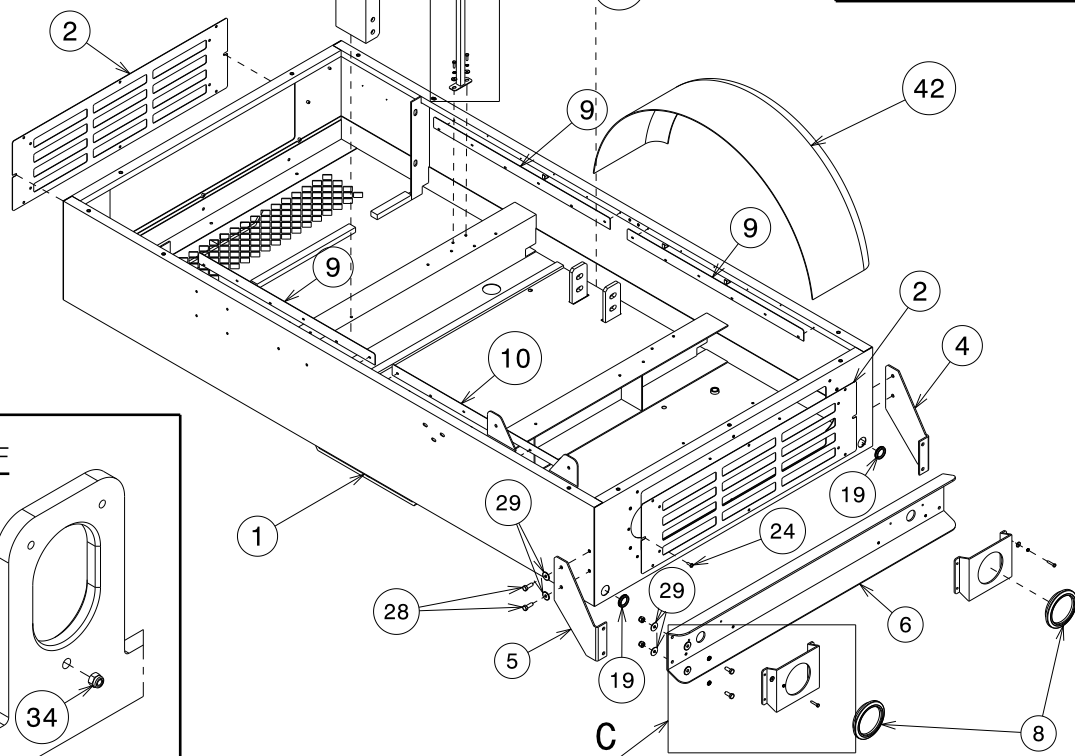
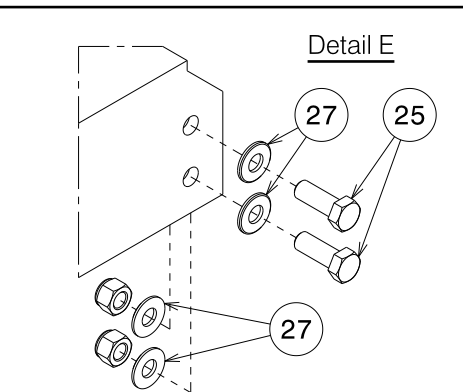
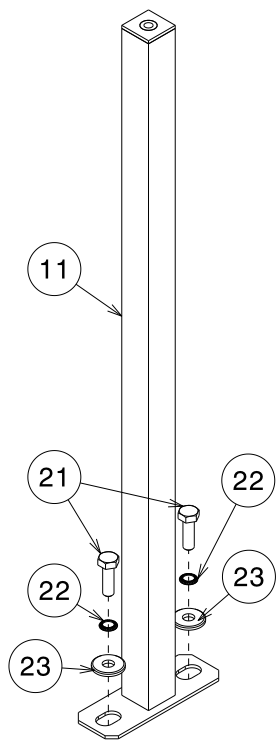
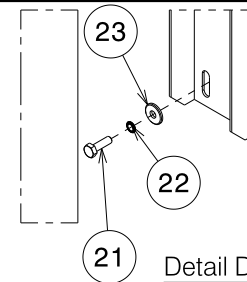
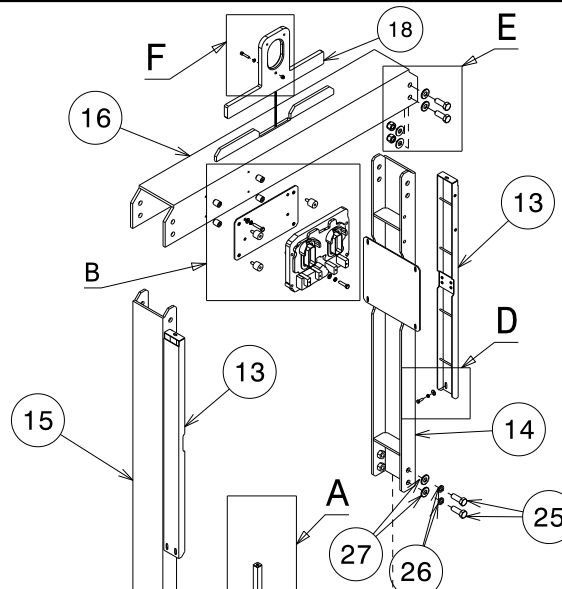
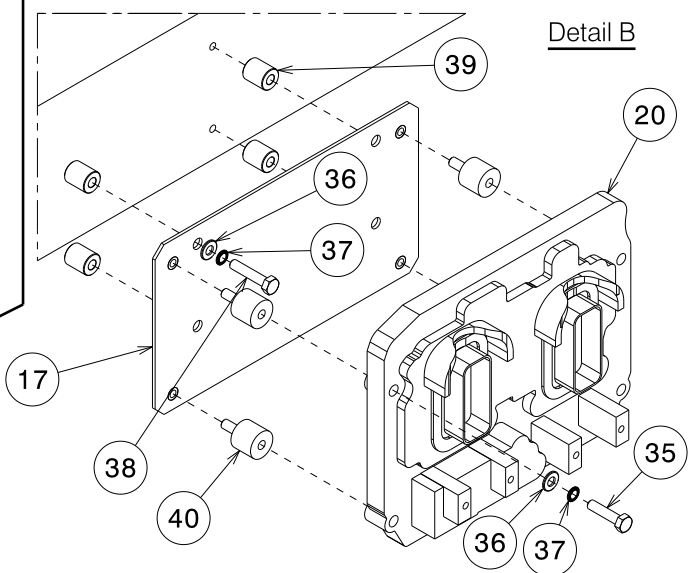
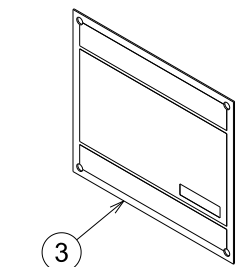



PARTS LIST

Motocompressor – D425 T4F

PARTS LEGENDA: Chassis

Tab. 01.1

POSITION	DESCRIPTION	PART No.	QUANTITY
1	Chassis	038-12005501-S	1
2	Front / Rear panel	124-309222-S	2
3	Serial No. plate	238-14761-S	1
4	Right bumper blade	120-220934-S	1
5	Left bumper blade	120-220932-S	1
6	Bumper	032-0120-S	1
7	Rear light support	120-220936-S	2
8	USA Light	142-0050-S	2
9	Door seal support blade	120-220920-S	3
10	Door seal support blade	120-220921-S	1
11	Support 42.2 for mudguard	010-2710-S	4
12	PVC cap 42.2 for mudguard support	106-405-S	4
13	Vertical support	120-220922-S	2
14	Hoisting hook right blade	017-055526-S	1
15	Hoisting hook left blade	017-055524-S	1
16	Hoisting hook upper blade	017-055522-S	1
17	Engine control unit support blade	010-309420-S	1
18	Hoisting hook	017-055520-S	1
19	Fairlead	239-040-S	2
20	Engine control unit	---	1
21	Hex head screw . M6x20	132-063-S	4
22	Washer d.6	015-250-S	12
23	Washer d. 6.6x18x2	015-029-S	12
24	Large head screw M6x20	243-010-S	16
25	Hex head screw M16x45	132-295-S	16
26	Elastic washers d.16	139-080-S	8
27	Plane washer d. 16x35x3	015-048-S	24
28	Hexagonal head screw M10x30 UNI 5739	132-143-S	4
29	Flat washer 10x30x2,5 UNI6593	015-033-S	12
30	Hex head screw M.10x25 UNI5739	132-142-S	4
31	Schnorr washer d.10	015-252-S	4
32	Hexagonal head Screw M6x30 UNI 5739	132-066-S	8
33	Hex socket head cap screw M8x30	133-134-S	1
34	Hex nut M8 UNI 7473	137-040-S	1
35	Hexagonal head screw M8x35 UNI 5739	132-104-S	4
36	Flat washer 8,4x17x1,5 UNI 6592	015-030-S	8
37	Schnorr washer d.8	015-251-S	8
38	Hex head screw M8x40 UNI 5739	132-105-S	4
39	Accelerator piston spacer L=22	009-10545-S	4
40	Silent block	061-0261-S	4
41	Flat washer 8	015-030-S	1
42	Mudguard	055-030-S	2
43	Mudguards support	010-309432-S	4

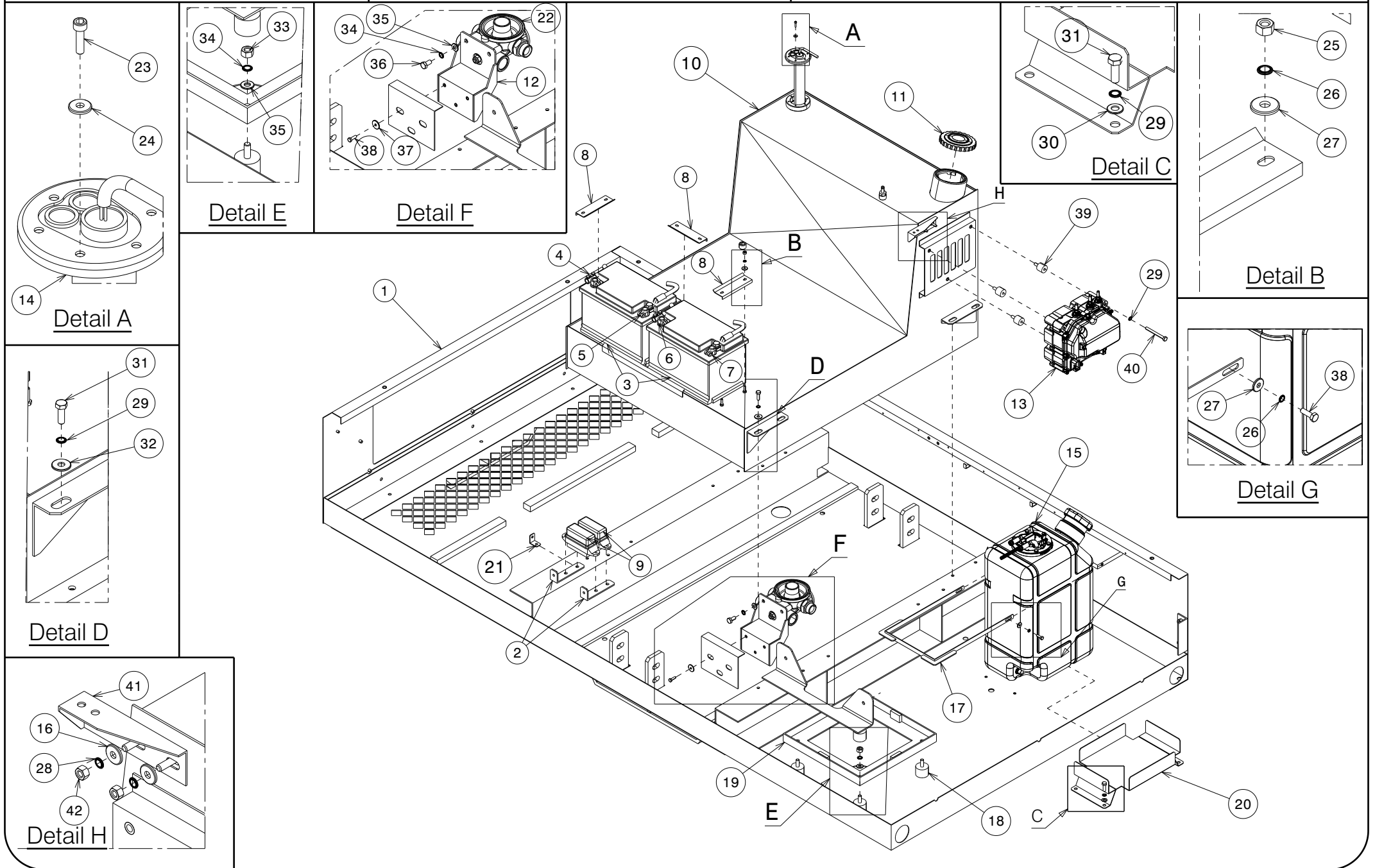



PARTS LIST

Motocompressor – D425 T4F

PARTS LEGENDA: Clampings to the chassis

Tab. 01.2

POSITION	DESCRIPTION	PART No.	QUANTITY
1	Chassis	038-12005501-S	1
2	Fuse box support blade	120-219776-S	2
3	Battery	174-007-S	2
4	Potitive battery cable L=1800	252-0781-S	1
5	Negative battery cable L=1800	252-080-S	1
6	Potitive battery cable L=1300	252-0405-S	1
7	Negative battery cable L=950	252-0520-S	1
8	Battery clamp	009-30505-S	3
9	Fuse box	----	2
10	Fuel tank	201-04215-S	1
11	Iron plug	193-01630-S	1
12	By-pass valve support blade	010-309426-S	1
13	SCR pump	---	1
14	Gasoil level control assembly	024-0192-F	1
15	"SCR AD Blue" tank	---	1
16	Washer d. 6.6x18x2	015-029-S	2
17	"AD Blue" tank resting blade	120-2209261-S	1
18	Silent block	061-028-S	4
19	Separator tank support base	034-019-S	1
20	"AD Blue" tank base	034-0200-S	1
21	Relé support blade	120-1590-S	1
22	By-pass valve assembly	024-0218-F	1
23	Hex socket head cap screw M4x16 UNI 5931	133-044-S	6
24	Flat washer 4,3x12x1,5	015-028-S	6
25	Hex nut M6 UNI 5587	135-030-S	6
26	Washer d.6	015-250-S	8
27	Washer d. 6.6x18x2	015-029-S	8
28	Washer d.6	015-250-S	2
29	Schnorr washer d.8	015-251-S	15
30	Flat washer 8,4x17x1,5 UNI 6592	015-030-S	4
31	Hex head screw M8x25 UNI 5739	132-102-S	8
32	Flat washer 8x24x2 UNI6593	015-031-S	8
33	Nut M10	135-050-S	4
34	Schnorr washer d.10	015-252-S	6
35	Flat washer 10,2x21x2	015-032-S	6
36	Hex head screw M10x20 UNI 5739	132-141-S	2
37	Flat washer 6x24x2 UNI6593	015-038-S	3
38	Hex head screw . M6x20	132-063-S	5
39	Silent block	061-0261-S	3
40	Hex head screw M8x80 UNI 5737	132-113-S	3
41	Valve support	010-309436-S	1
42	Nut M6	135-030-S	2

Up to Serial No. C40192

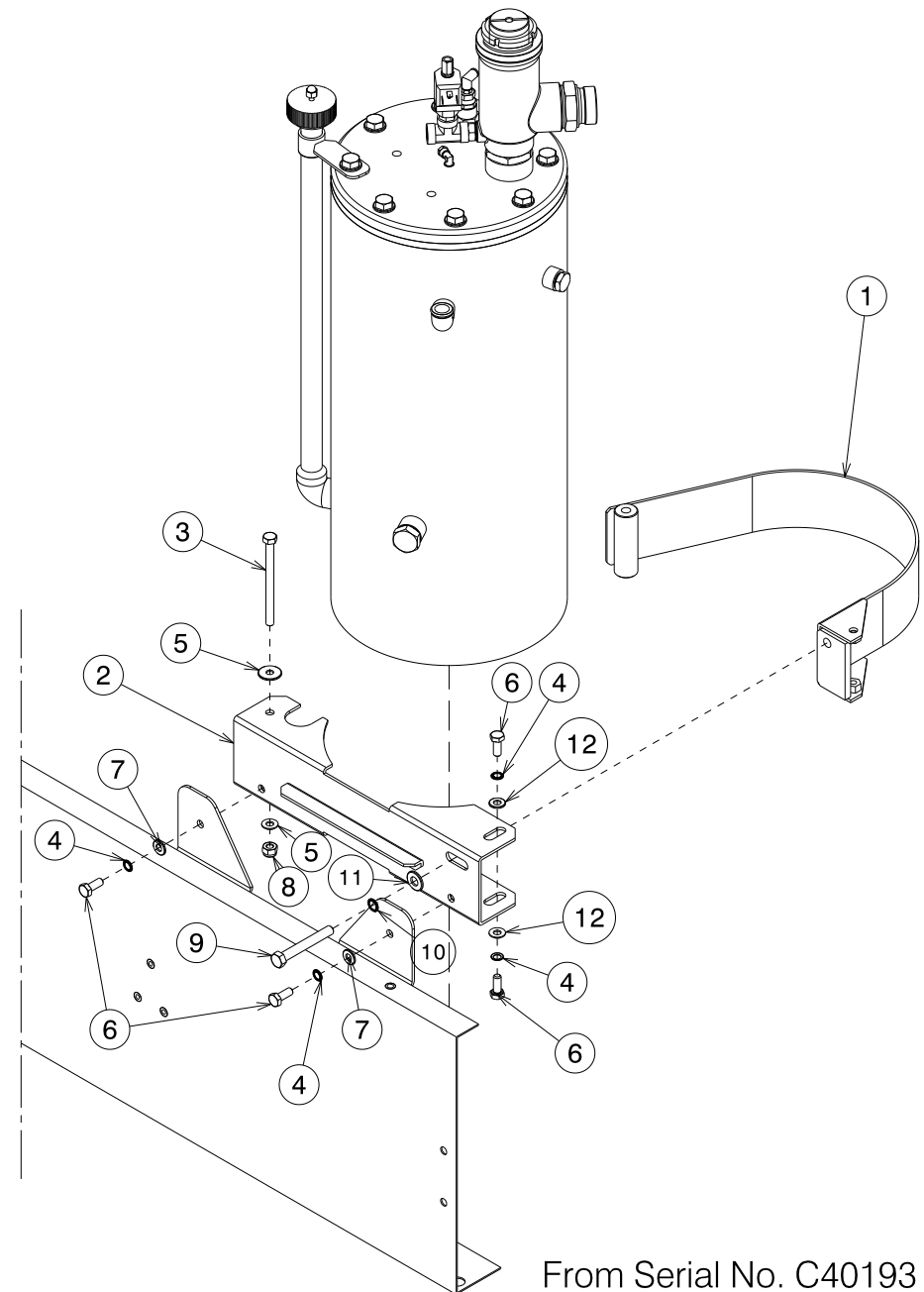
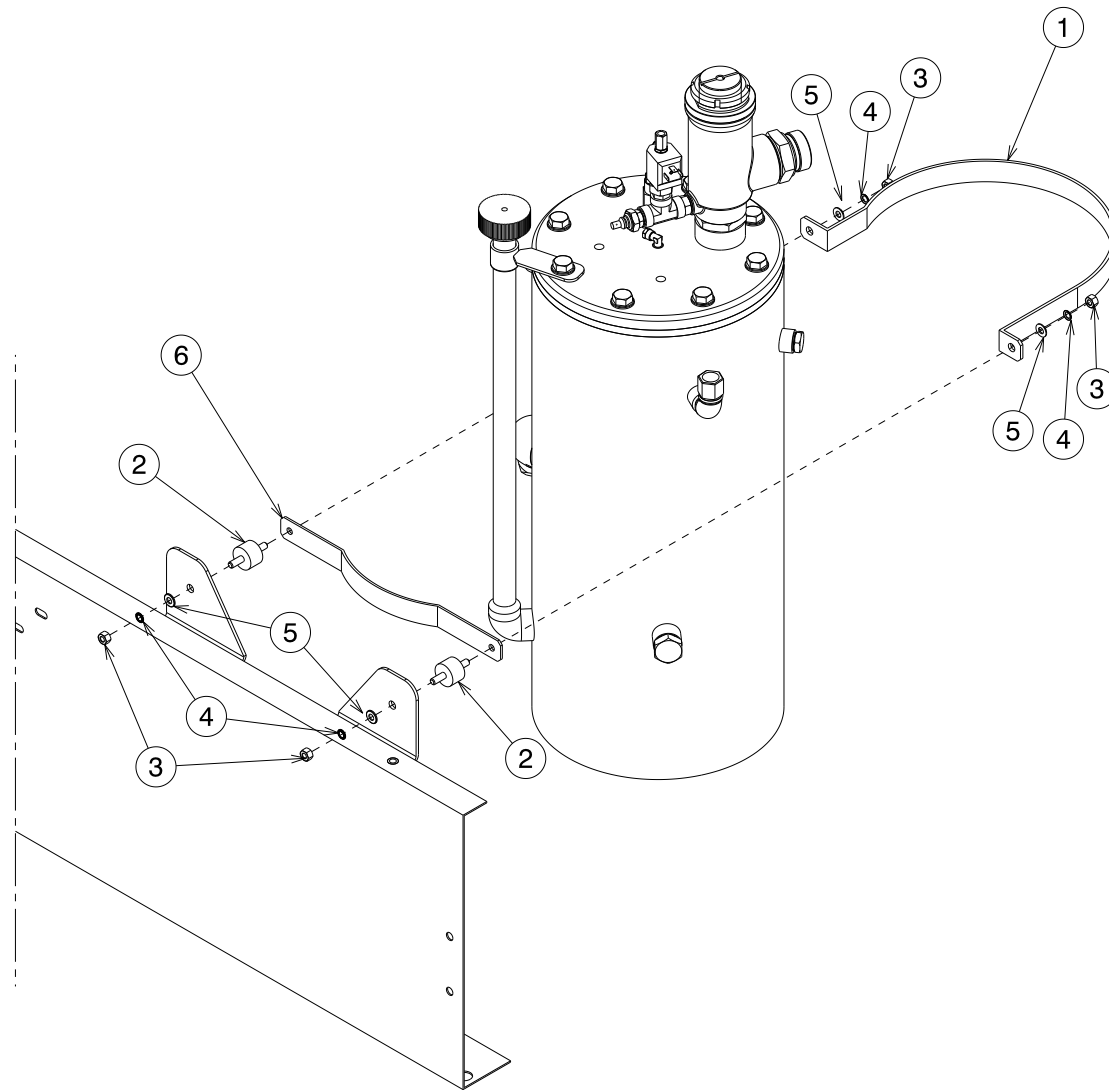

From Serial No. C40193



PARTS LIST

Motocompressor – D425 T4F

PARTS LEGENDA: Separator tank support

Tab. 01.3

POSITION	DESCRIPTION	PART No.	QUANTITY
Up to serial No.C40192			
1	Separator tank clamping ring	214-04552-S	1
2	Silent block	061-013-S	2
3	Hex nut M8 UNI 5587	135-040-S	4
4	Schnorr washer d.8	015-251-S	19
5	Flat washer 8,4x17x1,5 UNI 6592	015-030-S	8
6	Separator tank support blade	120-2193-S	1
From serial No.C40193			
1	Separator tank clamping ring	214-04582-S	1
2	Separator tank support blade	120-219352-S	1
3	Hexagonal head screw M10x130	132-163-S	1
4	Schnorr washer d.10	015-252-S	4
5	Flat washer 10x30x2,5 UNI6593	015-033-S	2
6	Hex head screw . M10x25	132-142-S	4
7	Flat washer 10,2x21x2	015-032-S	2
8	Self-locking nut M10	137-050-S	1
9	Hex head screw . M12x65	132-199-S	1
10	Schnorr washer d.12	015-254-S	1
11	Flat washer d. 12x30x4	015-03980-S	1
12	Flat washer d. 10x40	015-037-S	2

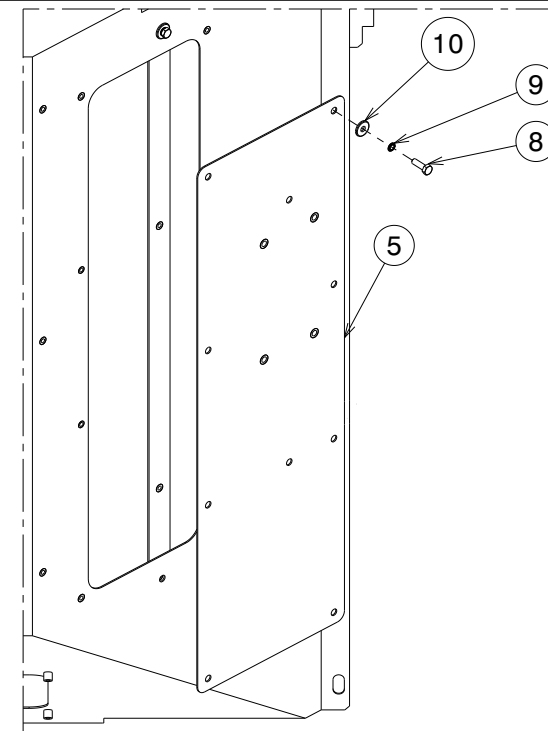
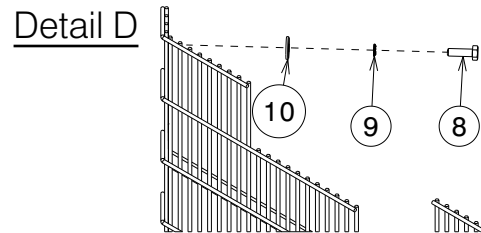
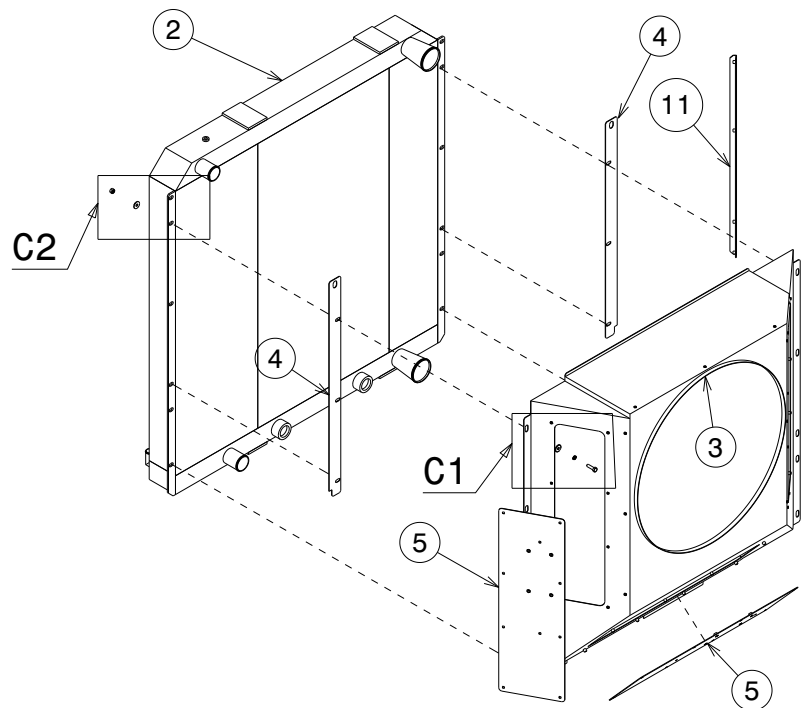

Fancover closing panel

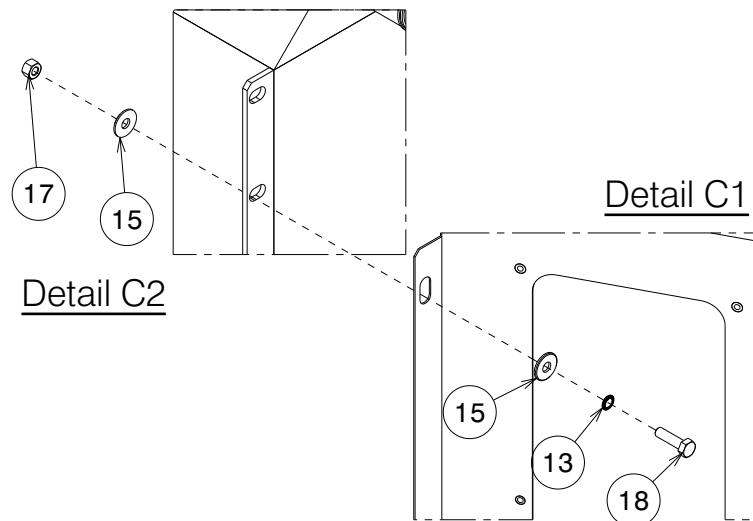
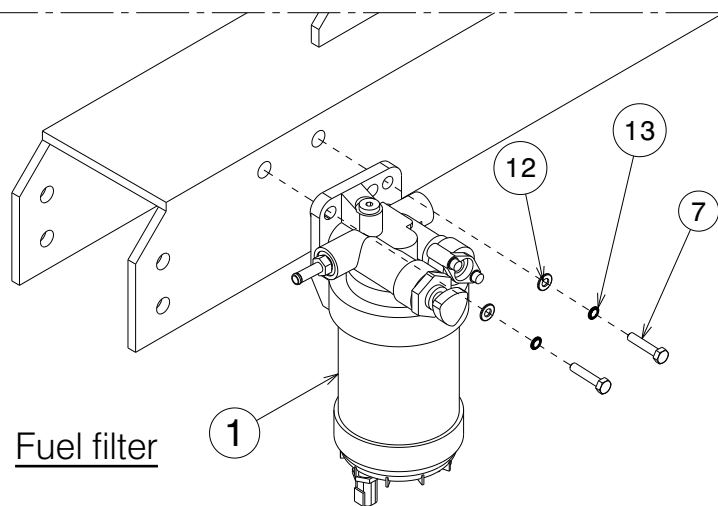
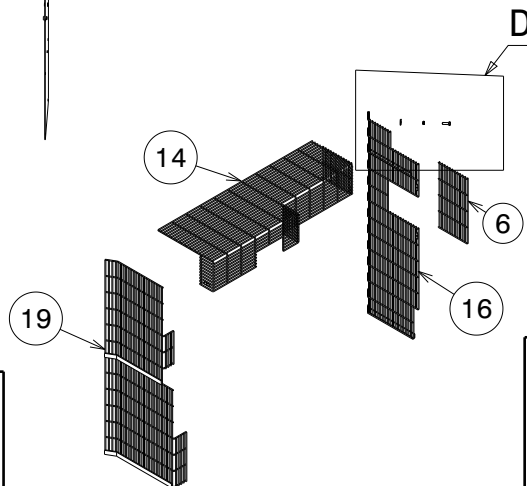



PARTS LIST

Motocompressor – D425 T4F

PARTS LEGENDA: Fancover - Radiator

Tab. 02

POSITION	DESCRIPTION	PART No.	QUANTITY
1	Fuel filter	191-0902-S	1
2	Radiator	011-032403-S	1
3	Fancover	001-02360-S	1
4	Radiator side blade	118-07890-S	2
5	Fancover closing panel	124-3092201-S	3
6	Alternator protection grid panel	124-309238-S	1
7	Hex head screw M8x40 UNI 5739	132-105-S	2
8	Hex head screw . M6x20	132-063-S	33
9	Washer d.6	015-250-S	31
10	Washer d. 6.6x18x2	015-029-S	33
11	Blade	120-220923-S	1
12	Flat washer 8,4x24x1,5 UNI 6592	015-031-S	2
13	Schnorr washer d.8	015-251-S	10
14	Fan protection grid panel Upper	124-309236-S	1
15	Flat washer 8x24x2 UNI6593	015-031-S	16
16	Fan protection grid panel Left	124-309234-S	1
17	Hex nut M8 UNI 5587	135-040-S	8
18	Hex head screw M8x30	132-103-S	8
19	Fan protection grid panel Right	124-309232-S	1

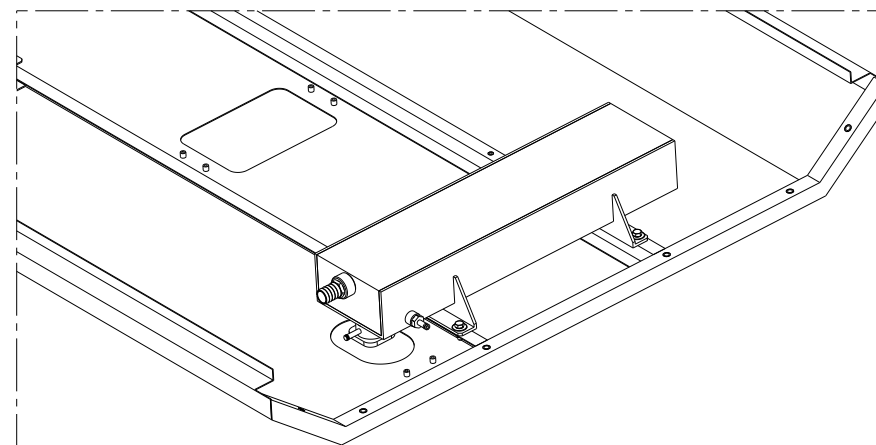
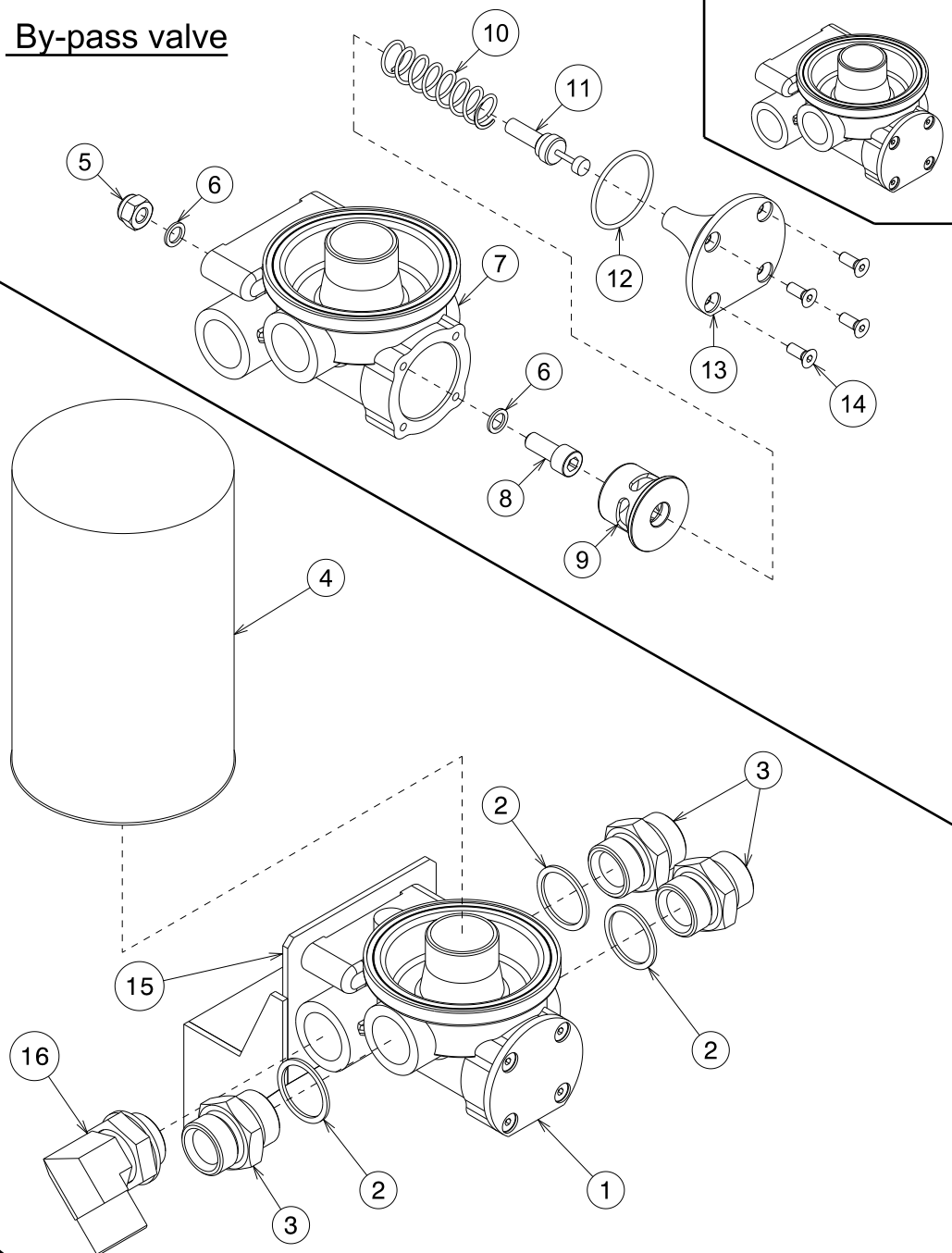
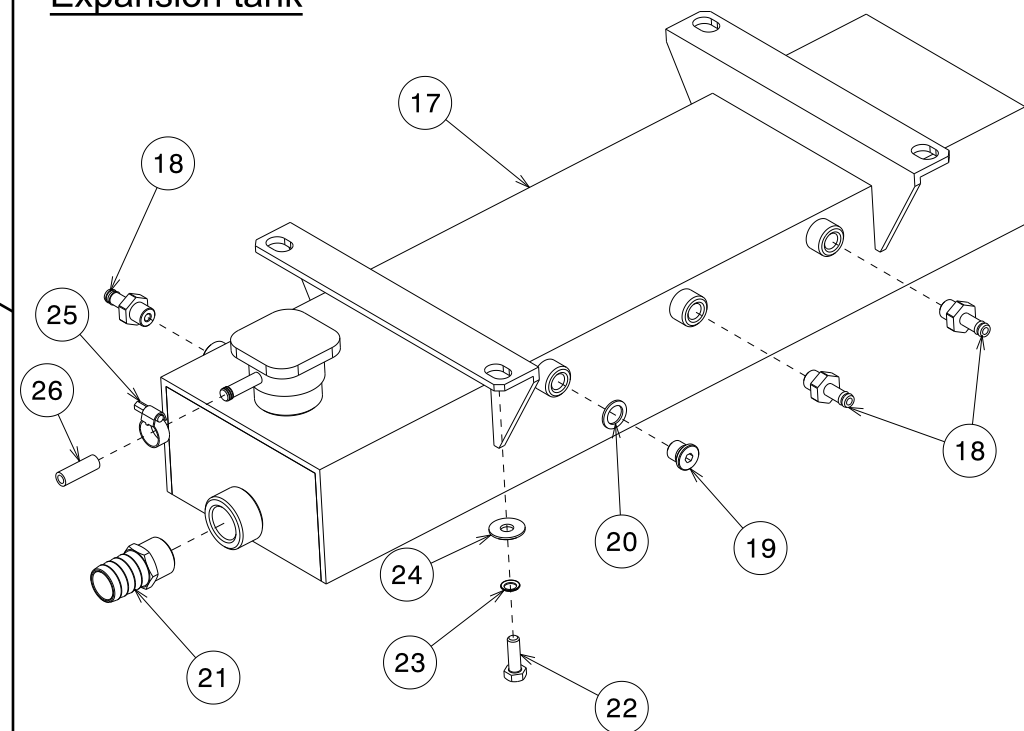
By-pass valveExpansion tank

Motocompressor –D425 T4F**PARTS LEGENDA: By-pass valve – Expansion tank**

Tab. 03

POSITION	DESCRIPTION	PART No.	QUANTITY
1	By-pass valve assembly	024-0218-F	1
2	Copper washer (1")	015-018-S	3
3	Double screw (1")	187-070-S	3
4	Oil filter	099-0095-S	1
5	Self-locking nut (M10)	137-050-S	1
6	Copper washer (1/8")	015-005-S	2
7	Thermostatic valve body	053-0568-S	1
8	T.C.E.I M10x25 screw	133-182-S	1
9	Spacer	009-1495-S	1
10	Spring	043-053-S	1
11	Thermostat	103-015-S	1
12	OR seal	023-1162-S	1
13	Valve plug	106-411-S	1
14	T.S.E.I.M screw (M6x16)	146-092-S	1
15	By-pass valve support	010-309426-S	1
16	90° fitting M+M (1")	148-2987-S	1
17	Expansion tank	201-017860-S	1
18	M fitting (1/4") d.8	148-198.2-S	3
19	Plug (1/4")	106-086-S	1
20	Copper washer (1/4")	015-007-S	1
21	Joint M (3/4") for pipe d. 25	148-19970-S	1
22	Hex head screw M8x25 UNI 5739	132-102-S	4
23	Schnorr washer d.8	015-251-S	4
24	Flat washer 8x24x2 UNI6593	015-031-S	4
25	Pipe clamp d. 8/11	149-005-S	1
26	Kristal pipe 10x6	089-080-S	1

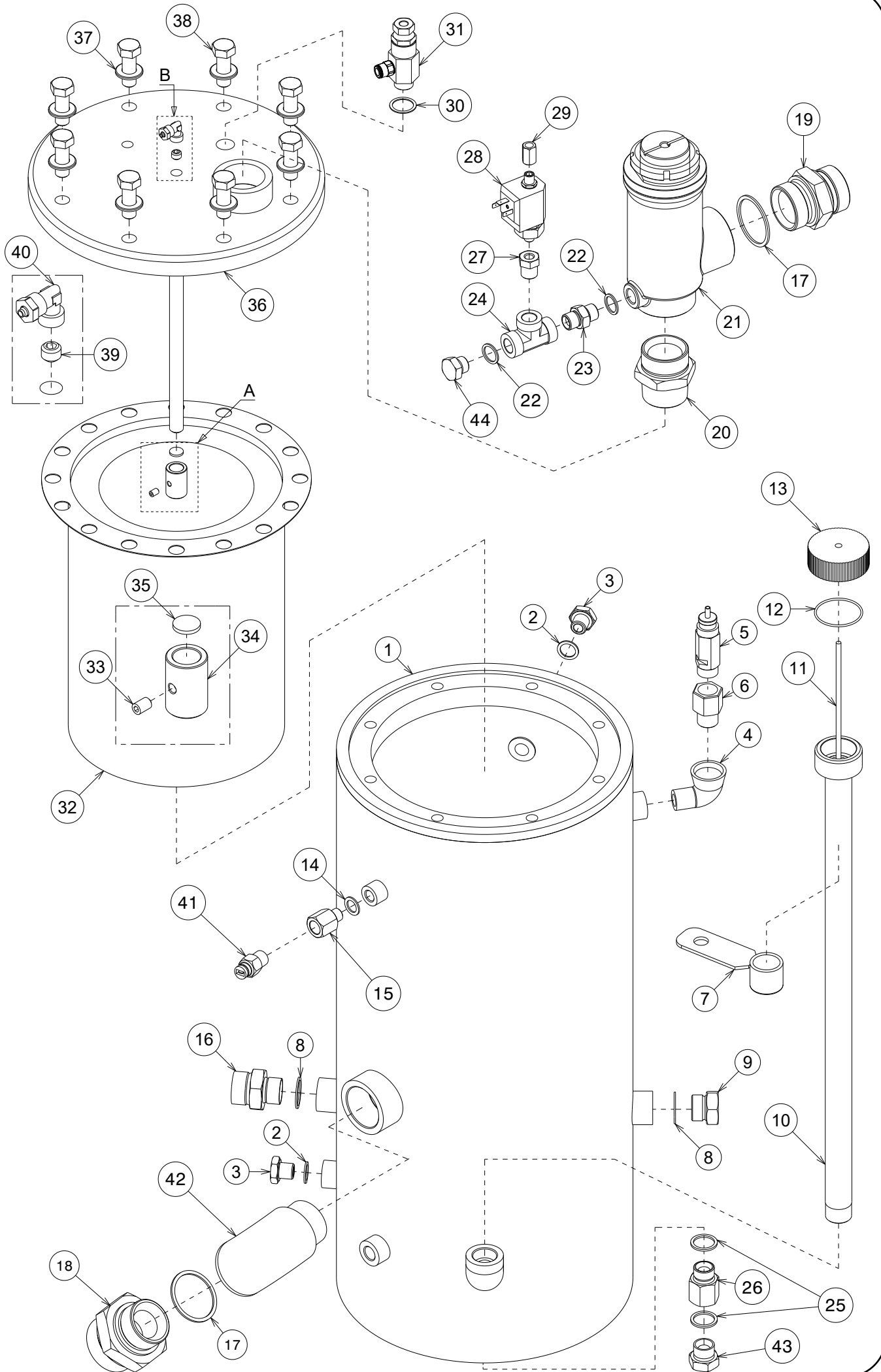

Motocompressor – D425 T4F

PARTS LEGENDA: Separator tank

Tab. 04

POSITION	DESCRIPTION	PART No.	QUANTITY
1	Separator tank 43 lt - USA version	037-0345-S	1
2	Copper washer (d.16,2x22x1.5)	015-009-S	2
3	Male hexagonal head iron plug (M16x1.5)	106-100-S	2
4	Short radius curve M+F (1/2") –USA version	111-030-S	1
5	Safety valve (1/2") –USA version	033-059-S	1
6	M+F extension (1/2") –USA version	189-007-S	1
7	Oil level filler clamping ring	214-004.5-S	1
8	Copper washer (3/4")	015-015-S	2
9	Male hexagonal head iron plug (3/4")	106-130-S	1
10	Oil level check filler	059-029-S	1
11	Oil level rod	086-026-S	1
12	OR seal	023-047-S	1
13	Oil level rod plug	106-010-S	1
14	Copper washer (1/4")	015-007-S	1
15	Reduction extension M+F L=34 (1/4" – M16)	189-350-S	1
16	Double screw (3/4" – 1")	187-065-S	1
17	Copper washer (1 1/2")	015-019.10-S	2
18	Double screw (1 1/2" – 2")	187-100-S	1
19	Double screw (1 1/2")	187-090-S	1
20	Double screw + cil (1 1/2")	187-0906-S	1
21	Minimum pressure valve USA	024-03111-F	1
22	Copper washer (3/8")	015-010-S	2
23	Double screw + cil (3/8")	187-0252-S	1
24	T fitting F+F+F (3/8")	148-282.5-S	1
25	Copper washer	015-0121-S	2
26	Extension 1/2 M-1/2 F L=40	189-106-S	1
27	Low reduction M+F (3/8" – 1/8")	190-021-S	1
28	Solenoid valve (1/8")	160-052-S	1
29	Hexagonal spacer L=20 (1/8")	009-014-S	1
30	Copper washer (1/2")	015-012-S	1
31	Pressure regulation valve assembly	024-032.1-F	1
32	Separator filter	157-1462-S	1
33	Grub screw M.6x10	218-1405-S	1
34	Oil filter support bush	223-506-S	1
35	Filter d.14x2	099-225-S	1
36	Separator tank closing flange	004-0635-S	1
37	Washer Diam. 15 x 28 x 2,5	015-036-S	8
38	Hex head screw M14x40 UNI 5739	132-244-S	8
39	Grub screw (1/8")	218-001-S	1
40	Fitting 90' (1/4") for pipe d. 6	148-090-S	1
41	115' compressor thermo contact	103-008-S	1
42	Short radius elbow M+F (1 1/2")	111-061-S	1
43	Iron plug (1/2")	106-125-S	1
44	Iron plug (3/8")	106-106-S	1

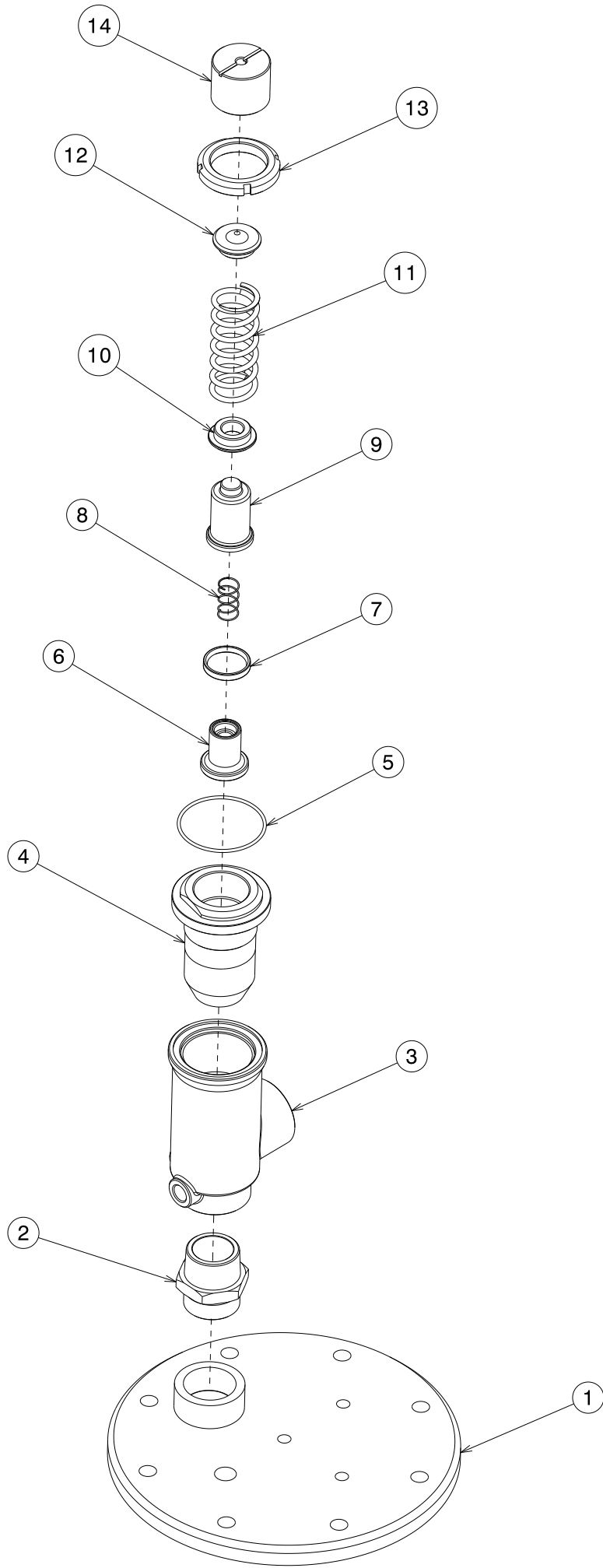



PARTS LIST

Motocompressor – D425 T4F

PARTS LEGENDA: Minimum pressure valve

Tab. 04.1

POSITION	DESCRIPTION	PART No.	QUANTITY
1	Separator tank closing flange	004-0635-S	1
2	Double screw (1" ½)	187-0906-S	1
3	Valve body minimum pressure valve	053-070-S	1
4	Bush	223-007-S	1
5	OR seal	023-062-S	1
6	Valve	033-056-S	1
7	OR	023-330-S	1
8	Spring	043-060-S	1
9	Valve piston	048-005-S	1
10	Clamping ring	214-005-S	1
11	Spring	043-044.1-S	1
12	Clamping ring	214-006-S	1
13	Min.Press.Valve Closure ring	194-0861-S	1
14	Adjustment screw	092-03551-S	1

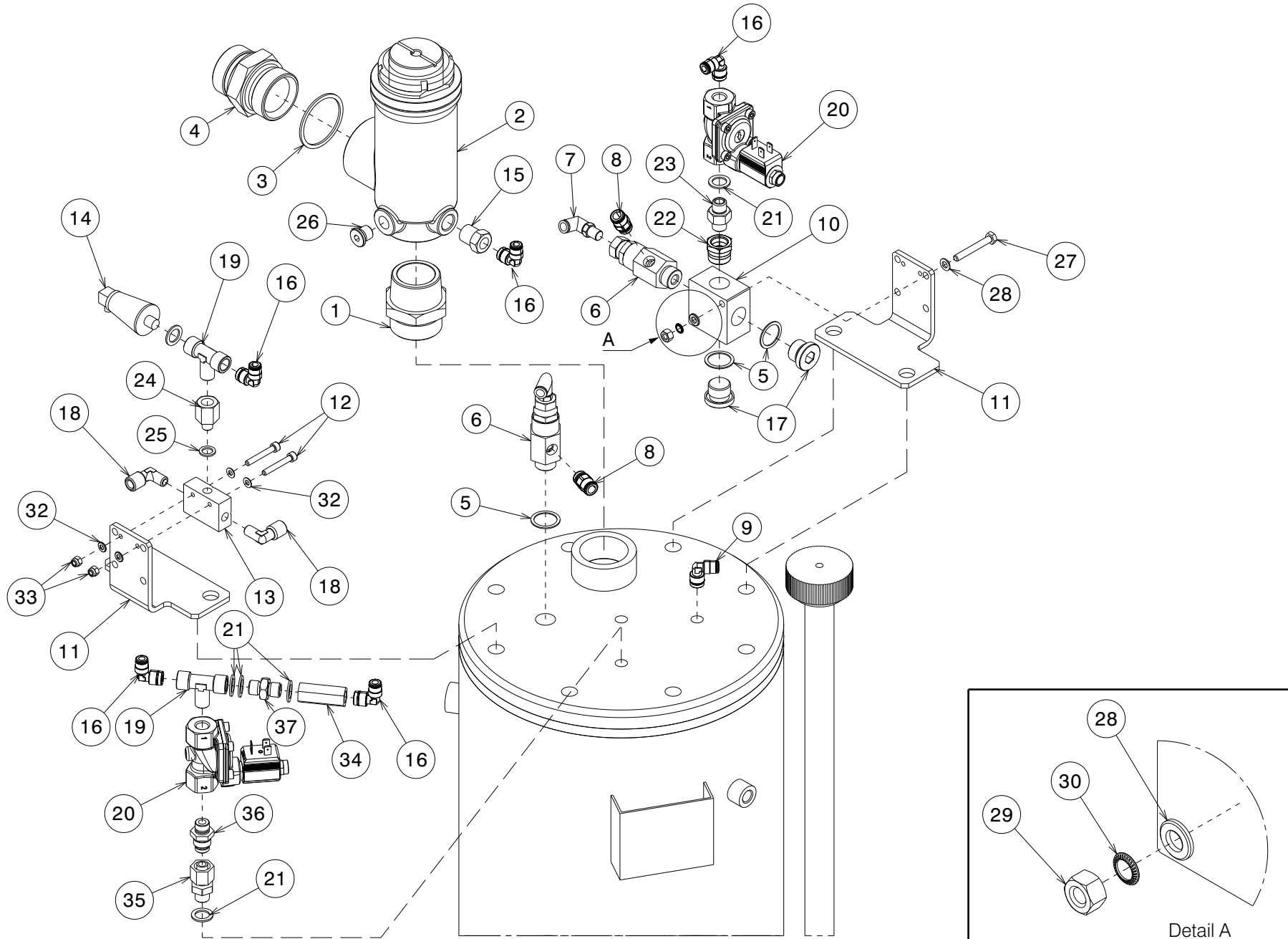

Motocompressor – D400T4F - D425 T4F**PARTS LEGENDA:** Double pressure version (7 – 10 bar)

Tab. 04.1.1

POSITION	DESCRIPTION	PART No.	QUANTITY
1	Double screw con+cil (1 1/2")	187-0906-S	1
2	Minimum pressure valve	024-0311-F	1
3	Copper washer (1 1/2")	015-019.10-S	1
4	Double screw (1" 1/2)	187-090-S	1
5	Copper washer (1/2")	015-012-S	3
6	Pressure regulation valve	024-032.1-F	2
7	Straight quick coupling (1/8") for pipe d.6	148-8001-S	1
8	Straight quick coupling (1/4") per tubo d.8	148-575-S	2
9	Quick coupling 90° (1/4") for pipe d.6	148-573-S	1
10	4-ways block body (1/2")	053-293-S	1
11	Valves support	010-31408-S	2
12	Hex socket head cap screw M5x35	133-056-S	2
13	OR valve	033-0850-S	1
14	Pressure transducer	205-030-S	1
15	Reduction 3/8 M conical to 1/4F	190-020-S	1
16	Quick coupling 90° (1/4") per tubo d.8	148-573.5-S	5
17	Hex socket head cap screw (1/2")	106-091-S	2
18	Quick coupling 90° (1/8") for pipe d.8	148-572-S	2
19	T fitting F+M+F (1/4")	148-194-S	1
20	Solenoid valve	160-0871-S	1
21	Copper washer (1/4")	015-007-S	5
22	Reduction (1/2") M conical to (1/4") F cylindrical	190-001-S	1
23	Double screw 1/4 cil.-1/4 con. hole 7	187-006-S	1
24	Extension F+M L=30 (1/4" – 1/8")	189-302-S	1
25	Copper washer (1/8")	015-005-S	1
26	Hex socket head cap screw (1/4")	106-086-S	1
27	Hex head screw M6x45	132-069-S	2
28	Flat washer 6,6x12x1,5 DIN125/1	015-027-S	4
29	Hex nut M6 UNI 5587	135-030-S	2
30	Washer d.6	015-250-S	2
31	Washer d. 6.6x18x2	015-029-S	4
32	Washer	015-078-S	4
33	Hex nut M5 UNI 7473	137-020-S	2
34	Non return valve (1/4")	033-0178-S	1
35	Straight coupling (1/4")	148-7115-S	1
36	Fitting (1/4")	148-740-S	1
37	Double screw (1/4")	187-005-S	1



PARTS LIST

Motocompressor –D400T4F - D425 T4F

PARTS LEGENDA: Engine – Air end

Tab. 05

POSITION	DESCRIPTION	PART No.	QUANTITY
1	Regulator assembly	024-1302-F	1
2	Copper washer D.18,2	015-011-S	3
3	Cummins engine spacer	009-30506-S	1
4	Screw M18x1,5	188-090-S	1
5	Fan	083-0182-S	1
6	Fan support	028-01286-S	1
7	Silent block	061-024762-S	4
8	Compressor support	027-06360-S	1
9	Flat washer	015-047-S	6
10	Fly-wheel	020-200010-S	1
11	Compressor-Engine coupling	006-149050-S	1
12	Right engine support	039-13062-S	1
13	Left engine support	039-13060-S	1
14	Engine "L" support	039-1153-S	1
15	Delivery clamping flange	004-047150-S	1
16	Compressor thermal contact 125°	103-0125-S	1
17	Airend (Standard version)	024-03291595-F	1
	Airend (Dual pressure 100 bar - 150 bar version)	024-03291593-F	1
18	Cummins engine	165-4380-S	1
19	Hex socket head cap screw M12x25	133-232-S	4
20	Hex socket head cap screw M16x35	133-332-S	4
21	Elastic washers d.16	139-080-S	8
22	Short radius elbow (2")	111-065-S	1
23	Hex head screw M16x35	132-293-S	4
24	Hex head screw M12x45 UNI 5739	132-195-S	6
25	Schnorr washer d.12	015-254-S	6
26	Flat washer 12,5x40x3	015-0405-S	6
27	Hex head screw M10x80 UNI5739	132-153.1-S	10
28	Schnorr washer d.10	015-252-S	20
29	Flat washer 10,2x21x2	015-032-S	12
30	Hex socket head cap screw M10x80 UNI 5931	133-193-S	2
31	Hex head screw 3/8-16 UNC L=2"3/4	132-70170-S	8
32	Hex head screw M12x40 screw	132-194-S	8
33	Hex head screw M8x30	132-103-S	8
34	Schnorr washer d.8	015-251-S	12
35	Flat washer 8,4x17x1,5 UNI 6592	015-030-S	12
36	Elastic washers	139-060-S	6
37	Hex head screw M8x25 UNI 5739	132-102-S	4
38	Hex socket head cap screw M10x30	133-183-S	4

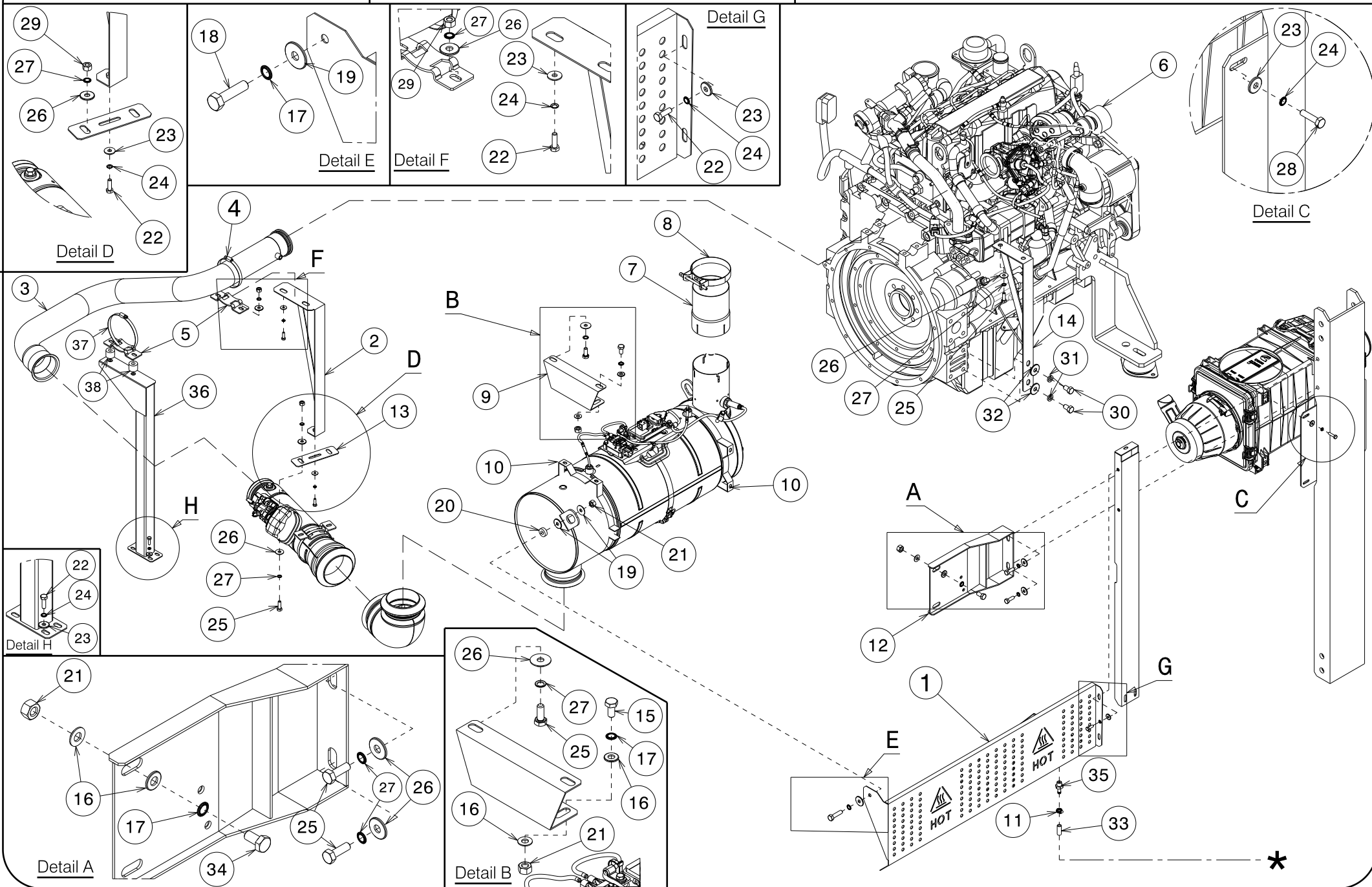

Motocompressor – D425 T4F

PARTS LEGENDA: Aftertreatment system

Tab. 06

POSITION	DESCRIPTION	PART No.	QUANTITY
1	Exhaust water conveyor	041-0833-S	1
2	“SCR” support blade	010-309440-S	1
3	“DRT” engine flex pipe	090-101204-S	1
4	Pipe clamp d.70x90	149-145-S	1
5	Clamp support	010-1530-S	3
6	Engine	165-4380-S	1
7	Exhaust manifold	119-04520-S	1
8	Clamp 104-112	149-1675-S	1
9	“SCR” vertical support blade	010-309424-S	1
10	“SCR” support clamp	149-37520-S	2
11	Pipe clamp 10x16	149-007-S	1
12	“DRT” support blade	010-309422-S	1
13	Adjustable blade	120-220940-S	1
14	Engine flex pipe support blade	010-309438-S	1
15	Hex head screw M10x20 UNI 5739	132-141-S	2
16	Flat washer 10,2x21x2	015-032-S	8
17	Schnorr washer d.10	015-252-S	5
18	Hex head screw M.10x40 UNI 5739	132-145-S	1
19	Flat washer 10x30x2,5 UNI6593	015-033-S	3
20	Spacer	009-087.5-S	1
21	Nut M10	135-050-S	5
22	Hex head screw . M6x20	132-063-S	4
23	Washer d. 6x24	015-029-S	11
24	Schnorr washer d.6	015-250-S	13
25	Hex head screw M8x25 UNI 5739	132-102-S	8
26	Flat washer 8x24x2 UNI6593	015-031-S	16
27	Schnorr washer d.8	015-251-S	12
28	Hex head screw screw M6x25 UNI 5739	132-065-S	4
29	Hex nut M8 UNI 5587	135-040-S	4
30	Hex head screw screw M12x20	132-190-S	2
31	Elastic washers	139-060-S	2
32	Flat washer 12x27	015-047-S	2
33	Kristall pipe d.12x8	089-090-S	1
34	Hex head screw M10x25 UNI 5739	132-142-S	2
35	M fitting (¼”) d.8	148-198.2-S	1
36	DRT pipe support blade	010-309439-S	1
37	DRT support clamp	149-161-S	1
38	Spacers	009-239-S	2
*	Drain on the botton of the frame		

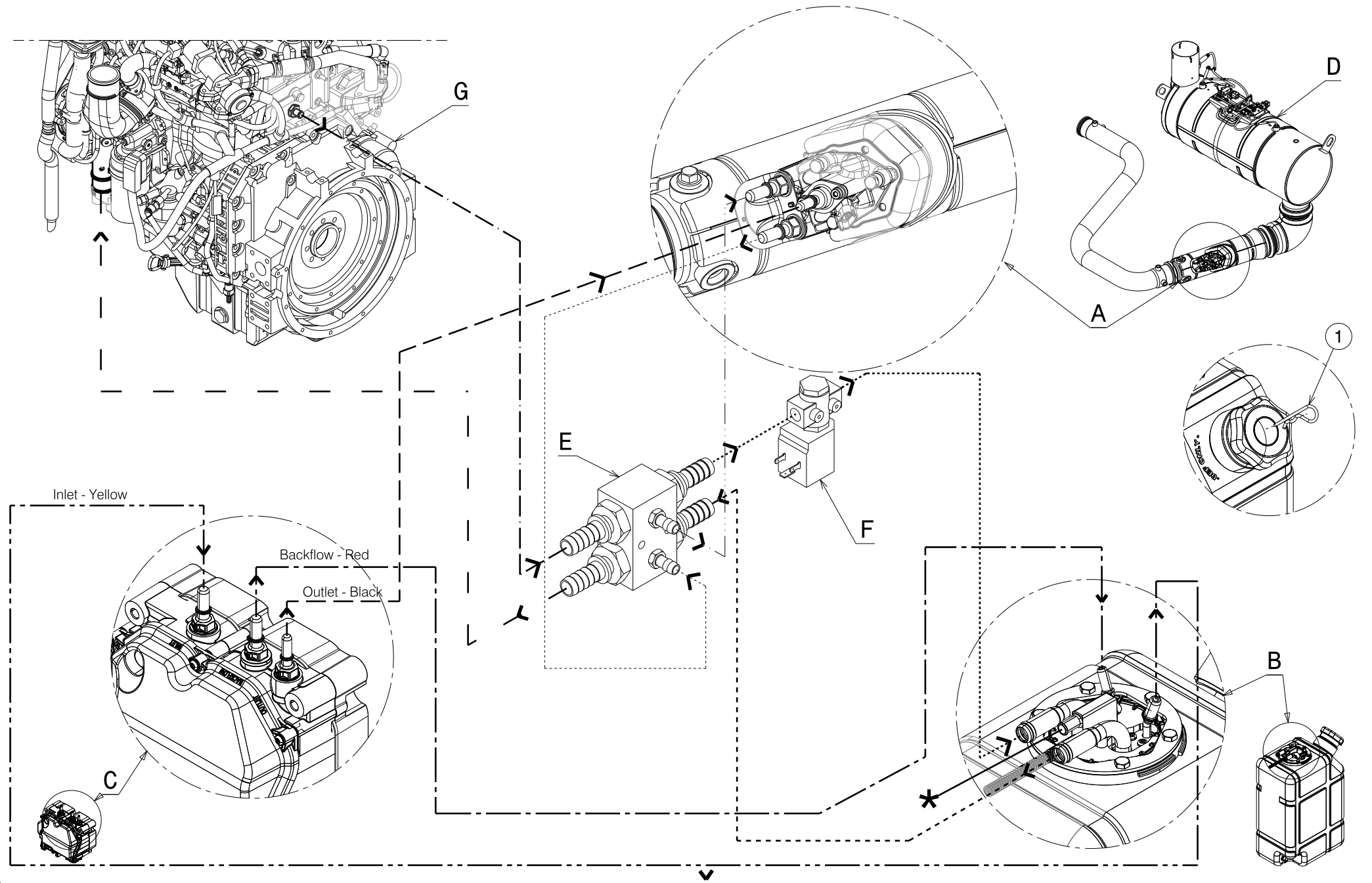



PARTS LIST

Motocompressor – D425 T4F

PARTS LEGENDA: Aftertreatment system

Tab. 06.1

POSITION	DESCRIPTION	PART No.	QUANTITY
	AFTERTREATMENT SYSTEM	044-055300-S	
A	DEF		
B	"AD BLUE" tank		
C	"AD BLUE" pump		
D	SCR		
E	6-ways block body		
F	Solenoid valve		
G	Engine		
1	Forelock	104-200-S	1
*	Drain on bottom frame		

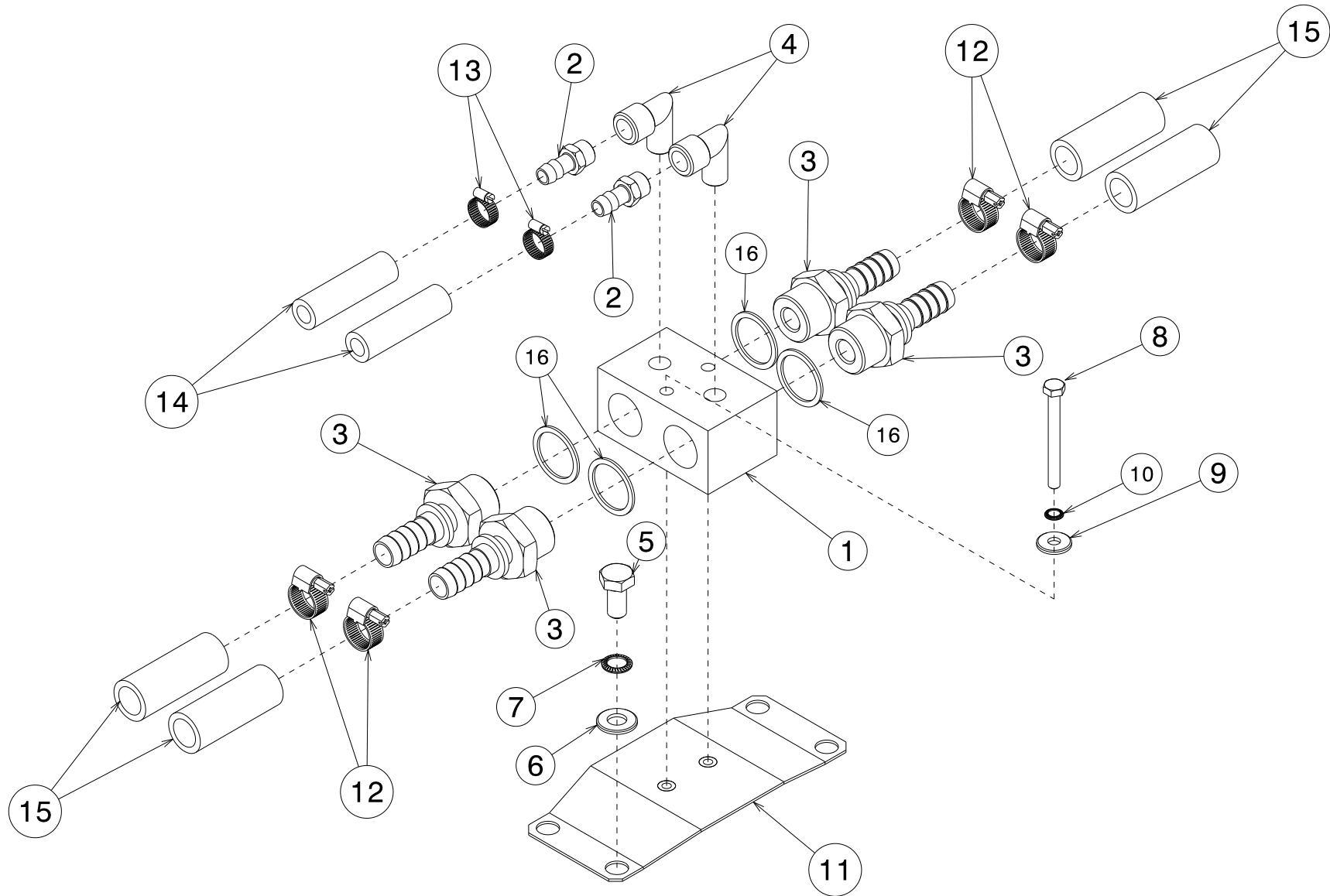



PARTS LIST

Motocompressor – D425 T4F

PARTS LEGENDA: Cooling system device block

Tab. 06.2

POSITION	DESCRIPTION	PART No.	QUANTITY
1	Cooling system devices coupling block	053-302-S	1
2	Fitting M (1/4") for pipe d.10	148-198.3-S	2
3	Fitting M (3/4") for pipe d.16	148-19965-S	4
4	90° M+F fitting (1/4")	148-143-S	2
5	Hex head screw M10x20 UNI 5739	132-141-S	4
6	Flat washer 10,2x21x2	015-032-S	4
7	Schnorr washer d.10	015-252-S	4
8	Hex head screw M6x60 UNI5739	132-072-S	2
9	Washer d. 6.6x18x2	015-029-S	2
10	Washer d.6	015-250-S	4
11	Cooling device block support blade	010-309434-S	1
12	Pipe clamp	149-011-S	4
13	Pipe clamp 10x16	149-007-S	2
14	Pipe 17x10	089-12100-S	2
15	Pipe 23x16	089-12106-S	4
16	Copper washer 3/4"	015-015-S	4

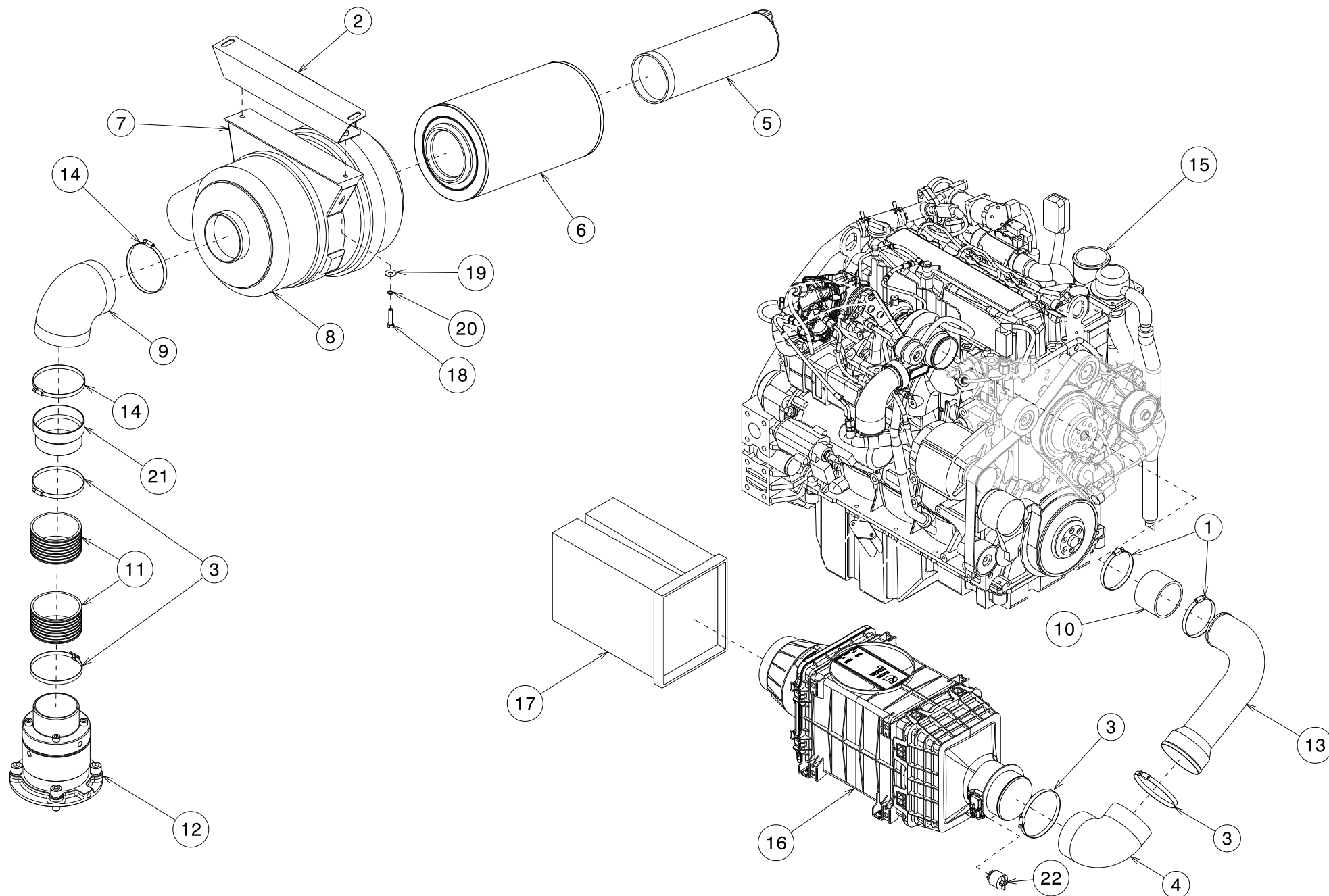



PARTS LIST

Motocompressor – D425 T4F

PARTS LEGENDA: Air filters cartridges

Tab. 07

POSITION	DESCRIPTION	PART No.	QUANTITY
1	Clamp SA 63/68	149-1452-S	2
2	Compressor air filter support	010-309428-S	1
3	Pipe clamp 90/110	149-161-S	4
4	MANN elbow d.100	111-108-S	1
5	Air filter cartridge	162-0081-S	1
6	Air filter cartridge	162-0080-S	1
7	MANN air filter support	010-2415-S	1
8	MANN filter support	014-421-S	1
9	MANN elbow d.110	111-109-S	1
10	High temperaure silicone pipe d.76	089-0425-S	3.25"
11	Ontario pipe d.100 USA Version	089-0502-S	2
12	Regulator assembly	024-130-F	1
13	Engine air intake pipe	064-200600-S	1
14	Pipe clamp d.100-120	149-16130-S	2
15	Engine	165-4380-S	1
16	Cummins air filter container	---	1
17	Engine air filter	---	1
18	Hex head screw M8x40 UNI 5739	132-105-S	2
19	Flat washer 8x24x2 UNI6593	015-031-S	2
20	Schnorr washer d.8	015-251-S	2
21	Reduction 110/100	190-610-S	1
22	Air filter clogging signaller	E-220413130	1

Cod.28

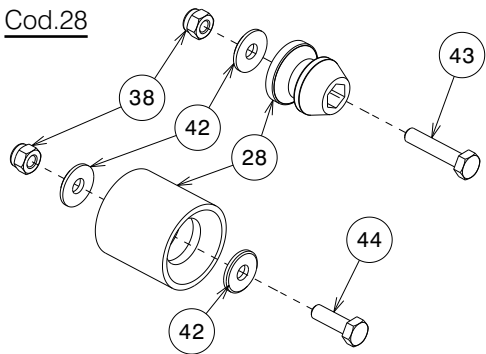

Detail A

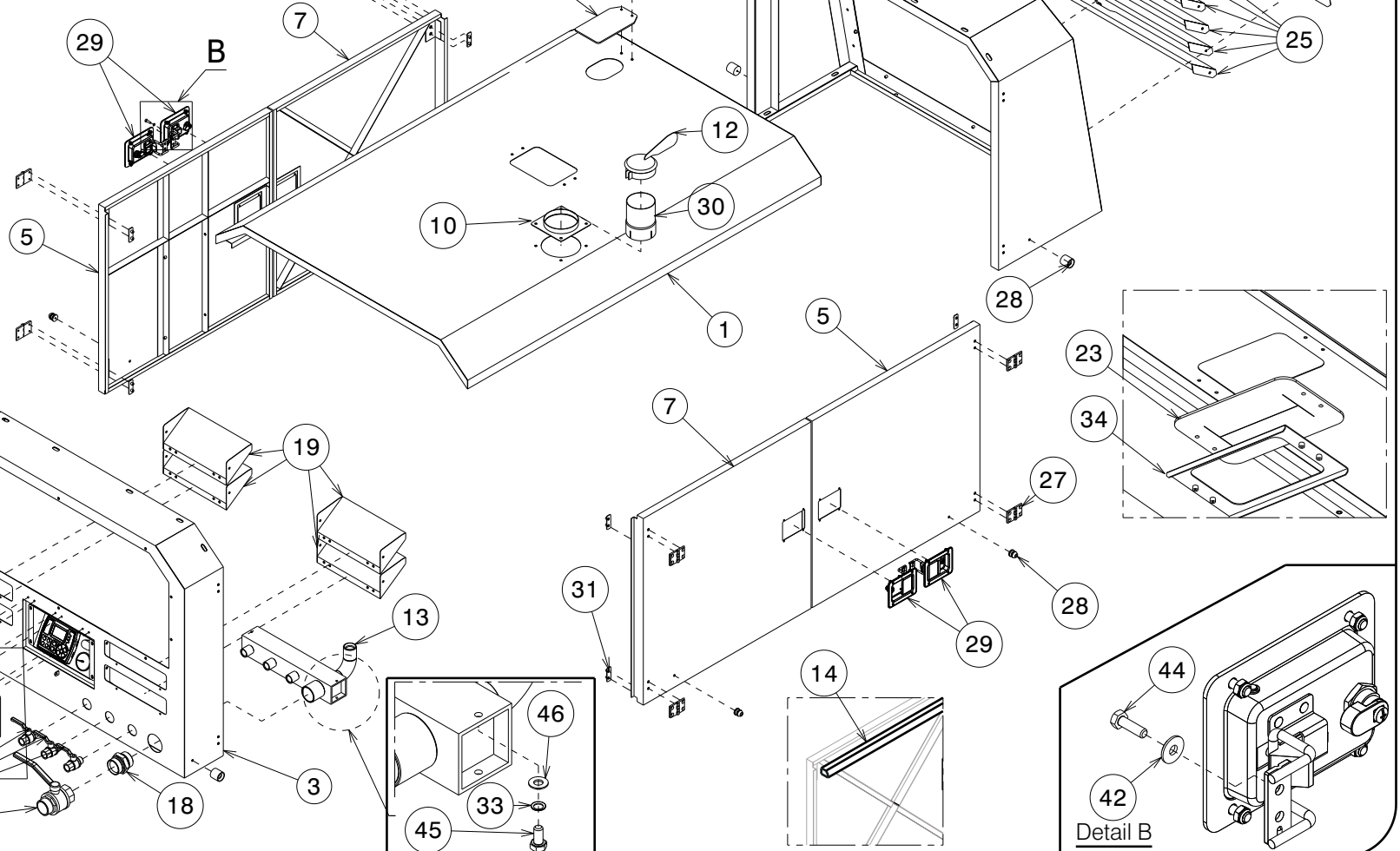
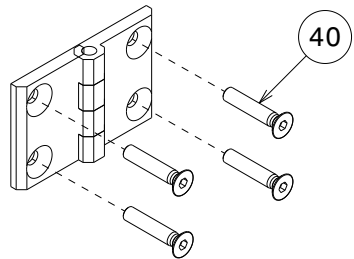
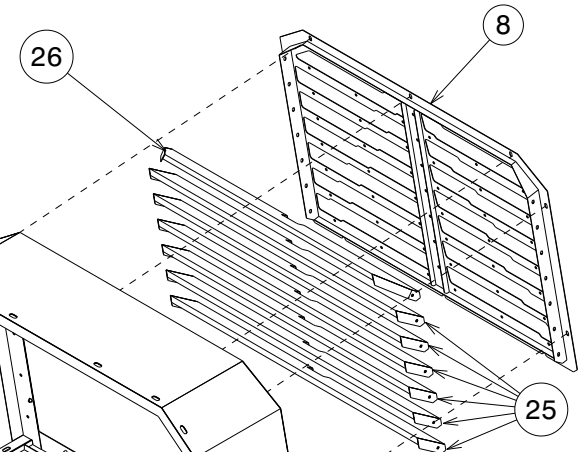
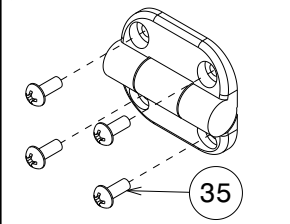
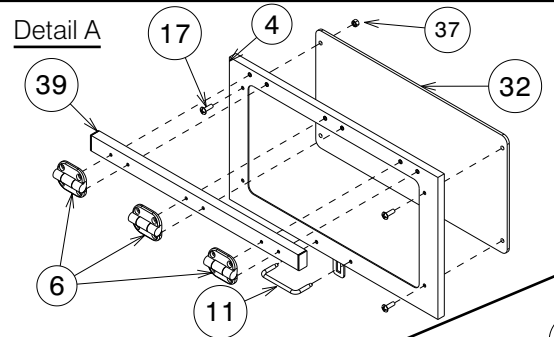

A

B

Detail B



PARTS LIST

Motocompressor – D425 T4F

PARTS LEGENDA: Canopy

Tab. 08

POSITION	DESCRIPTION	PART No.	QUANTITY
1	Central body	036-0435041-S	1
2	Front body	036-043500-S	1
3	Rear body	036-043502-S	1
4	Control panel door	110-11104-S	1
5	Front left door	110-11101-S	2
6	Hinge	007-032-S	3
7	Front right door	110-11103-S	2
8	Air intake panel (rear)	022-049825-S	1
9	Air intake panel (front)	022-049826-S	1
10	Exhaust protection carter	005-0635-S	1
11	Handle	209-021-S	1
12	Exhaust rain cover	032-0330-S	1
13	Exit valves coupling	063-116025-S	1
14	Rubber gasket	023-2305-S	36 feet
15	Ball valve connection M+F (3/4")	152-030-S	3
16	Ball valve connection M+F (2")	152-070-S	1
17	Poelier screw 6x16	243-009-S	4
18	Double screw (2")	187-105-S	1
19	Short soundproofing air intake panel (Rear)	124-309230-S	4
20	Soundproofing air intake panel (Rear)	124-309228-S	3
21	Upper soundproofing air intake panel (Rear)	124-3092245-S	1
22	Rubber plate	177-200-S	1
23	Rubber plate for hosting hook	177-1970-S	1
24	Plate	208-004-S	1
25	Soundproofing air intake panel (Front)	124-309226-S	6
26	Upper soundproofing air intake panel (Front)	124-309224-S	1
27	Hinge 50x76	007-0343-S	8
28	Door clamp	197-015-S	8
29	Handle	209-0226-S	4
30	Exhaust manifold	119-04520-S	1
31	Doors clamping blade	120-323825-S	8
32	Plexiglass panel	057-02130-S	1
33	Schnorr washer d.10	015-252-S	2
34	Fixing blade hosting hook rubber plate	120-220925-S	1
35	Countersunk cross head screw 4x10	243-088-S	12
36	Large head screw M6x16	243-009-S	86
37	Nut M5	135-020-S	4
38	Hex nut M6 UNI 7473	137-030-S	8
39	Control panel blade	120-220938-S	1
40	Countersunk hexagon head screw 6x25 UNI 5933	146-094-S	32
41	Washer d.6	015-250-S	14
42	Washer d. 6.6x18x2	015-029-S	32
43	Hexagonal head Screw M6x30 UNI 5739	132-066-S	4
44	Hex head screw . M6x20	132-063-S	12
45	Hex head screw . M10x20	132-141-S	2
46	Flat washer 10,2x21x2	015-032-S	2

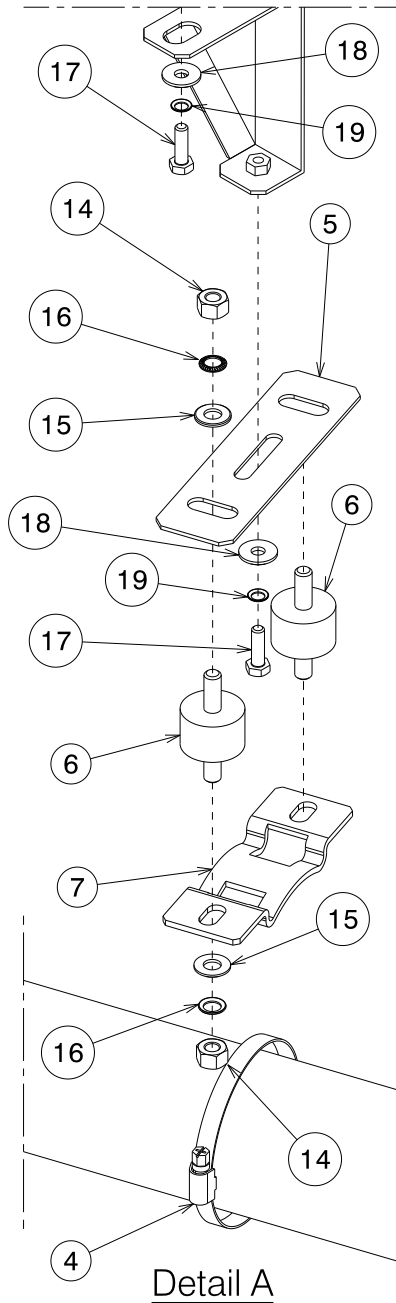

Detail A

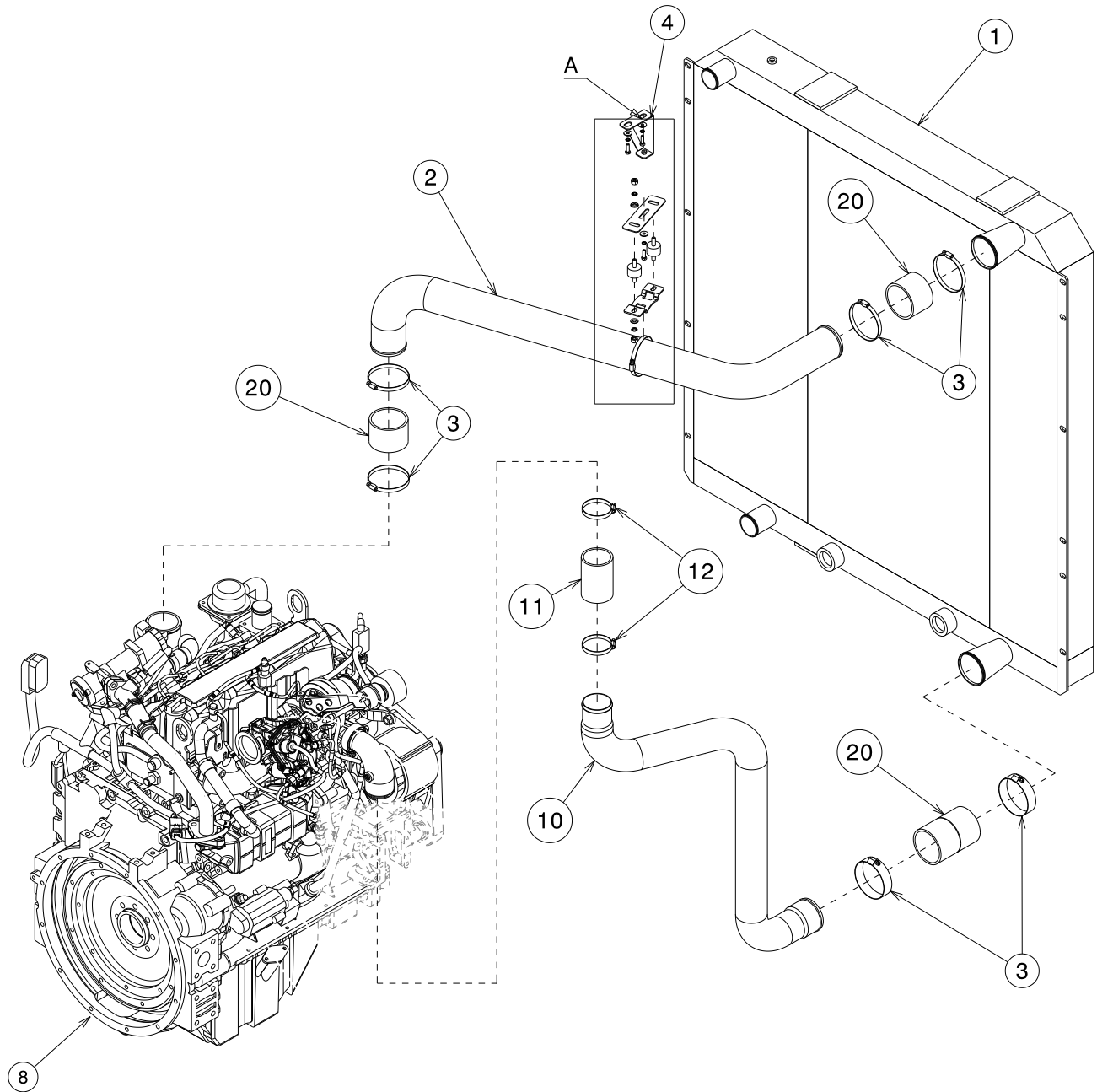



PARTS LIST

Motocompressor – D425 T4F

PARTS LEGENDA: Connections

Tab. 09.1

POSITION	DESCRIPTION	PART No.	QUANTITY
1	Radiator	011-032403-S	1
2	Intercooler inlet pipe	064-200602-S	1
3	Pipe clamp d.70x90	149-1454-S	6
4	Intercooler inlet pipe support	010-309444-S	1
5	Adjustable blade	120-220940-S	1
6	Silent block	061-013-S	2
7	Clamp support	010-1530-S	1
8	Engine	165-4380-S	1
9	Clamp 70x90	149-1452-S	2
10	Intercooler outlet pipe	064-200604-S	1
11	Silicone pipe d.60	089-0326-S	4.70 "
12	Pipe clamp d.60x80	149-1420-S	2
13	Intercooler outlet pipe support	010-309442-S	1
14	Hex nut M8 UNI 5587	135-040-S	4
15	Flat washer 8,4x17x1,5 UNI 6592	015-030-S	4
16	Schnorr washer d.8	015-251-S	4
17	Hex head screw . M6x20	132-063-S	3
18	Washer d. 6.6x18x2	015-029-S	3
19	Washer d.6	015-250-S	3
20	Radiator silicone pipe d.76	089-0425-S	4.70 "

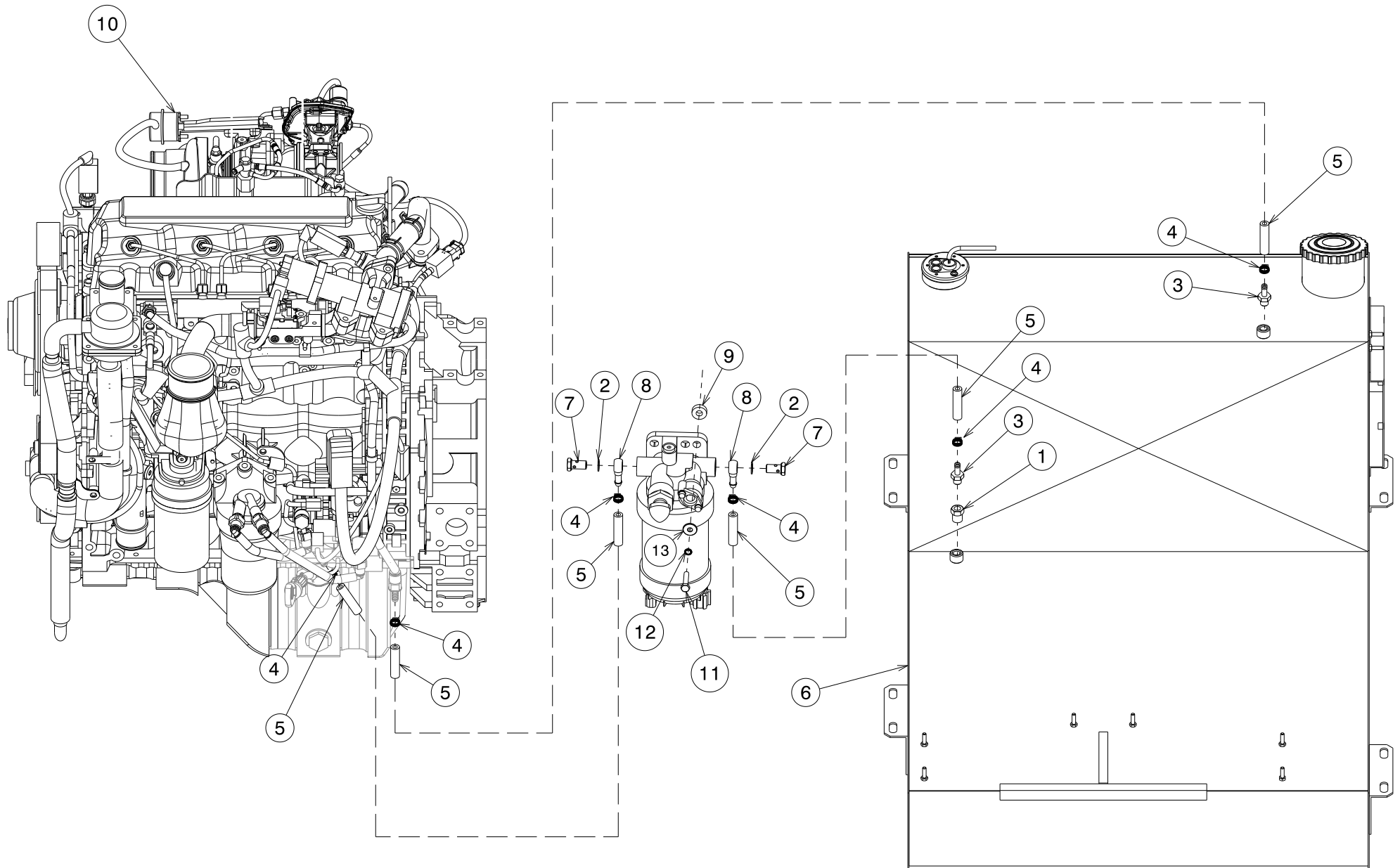



PARTS LIST

Motocompressor – D425T4F

PARTS LEGENDA: Fuel tank connections

Tab. 09.2

POSITION	DESCRIPTION	PART No.	QUANTITY
1	Reduction M+F (3/8" – 1/4")	190-020-S	1
2	Copper washer 14x20x1,5	015-008-S	2
3	Fitting M (1/4") for pipe d.8	148-198.2-S	2
4	Clamp d.10x16	149-007-S	6
5	Anti-oil pipe for fuel d.15x8	089-1203-S	3
6	Fuel tank	201-04215-S	1
7	Screw M.14x1,5	188-060-S	2
8	Eye connection D.10	148-400-S	2
9	Spacer	009-087.5-S	2
10	Engine Cummins	165-4380-S	1
11	Hex head screw M8x40 UNI 5739	132-105-S	2
12	Schnorr washer d.8	015-251-S	2
13	Flat washer 8x24x2 UNI6593	015-031-S	2

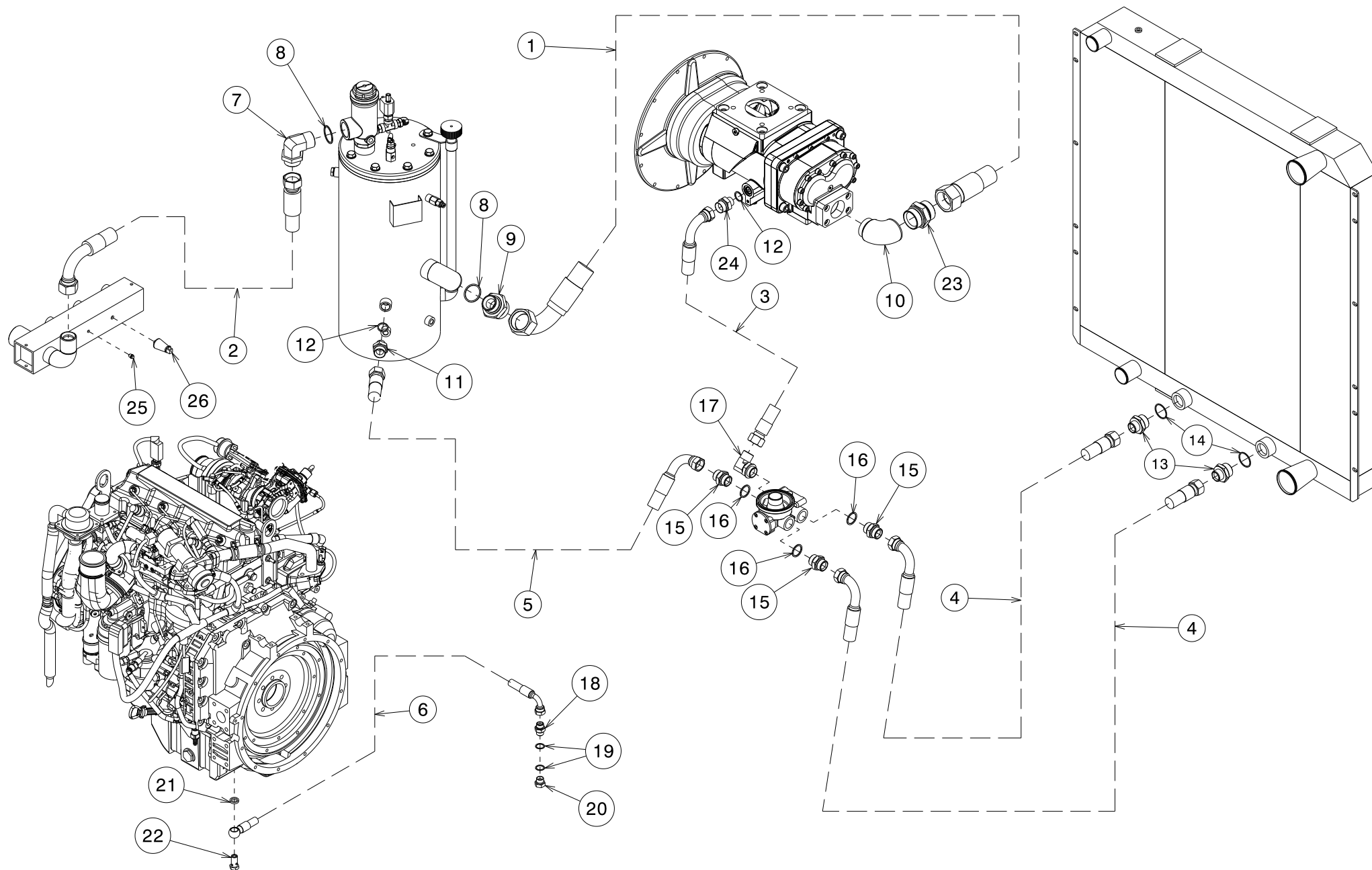



PARTS LIST

Motocompressor –D425T4F

PARTS LEGENDA: Oleopneumatic system

Tab. 09.3

POSITION	DESCRIPTION	PART No.	QUANTITY
1	Piping (2")	065-497.20-S	1
2	Piping (1 ½")	065-314.01-S	1
3	Piping (1")	065-255.51-S	1
4	Piping (1")	065-252.70-S	2
5	Piping (1")	065-253.6-S	1
6	Piping (1/2")	065-176.410-S	1
7	90° fitting (1" ½)	148-2988-S	1
8	Copper washer (1 ½")	015-019.10-S	2
9	Double screw (2" – 2" ½)	187-100-S	1
10	Short radius elbow (2")	111-065-S	1
11	Double screw (¾" a 1") foro 19.1	187-065-S	1
12	Copper washer (¾")	015-015-S	2
13	Double screw (1" a " ¼)	187-075-S	2
14	Copper washer (1" ¼)	015-019-S	2
15	Double screw (1")	187-070-S	3
16	Copper washer (1")	015-018-S	3
17	90° fitting M+M (1")	148-2987-S	1
18	Double screw (½" foro 12.6)	187-045-S	1
19	Copper washer (½")	015-012-S	2
20	Iron plug (½")	106-125-S	1
21	Cummins engine spacer	009-30506-S	1
22	Screw M18x1,5	188-090-S	1
23	Double screw 2"	187-105-S	1
24	Double screw 1"	187-0730-S	1
25	Square head plug (1/8")	106-020-S	1
26	Pressure transducer	205-030-S	1

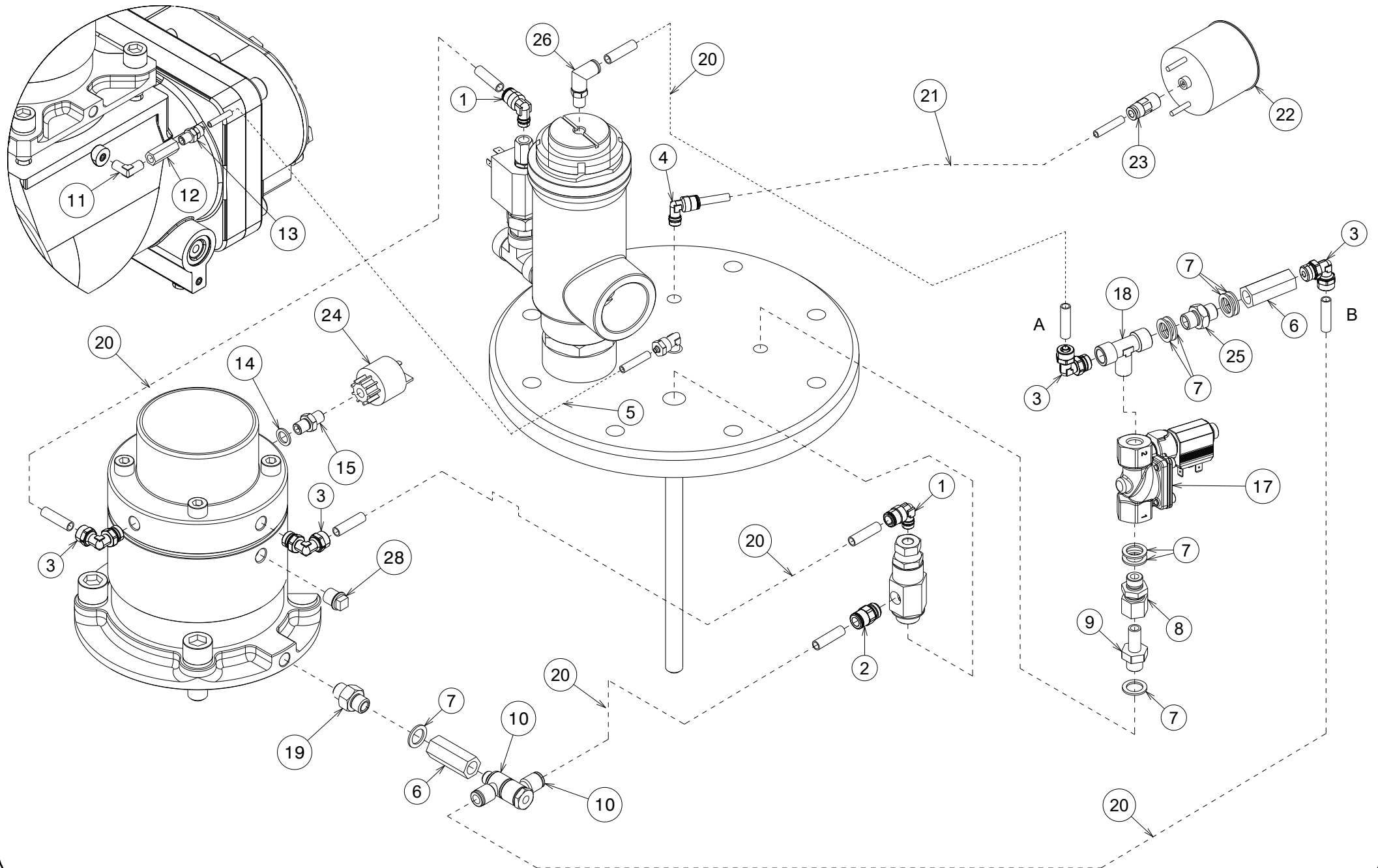



PARTS LIST

Motocompressor – D425T4F

PARTS LEGENDA: Pneumatic system

Tab. 09.4

POSITION	DESCRIPTION	PART No.	QUANTITY
1	90° quick coupling (1/8") for pipe d.8	148-572-S	2
2	Straight quick coupling (1/4") for pipe d.8	148-575-S	1
3	90° quick coupling (1/4") for pipe d.8	148-573.5-S	2
4	90° quick coupling (1/8") for pipe d.6	148-570-S	1
5	Polyamides pipe d.6	089-060-S	1
6	Non-return valve (1/4")	033-017-S	2
7	Copper washer (1/4")	015-007-S	8
8	Fitting (1/4")	148-740-S	1
9	Straight coupling(1/4")	148-7115-S	1
10	Super quick coupling (1/4")	148-5901-S	2
11	Fitting 90° Mcon (1/8")	148-288-S	1
12	Non-return valve (1/8")	033-001-S	1
13	Straight coupling (1/8") for pipe d.6	148-040-S	1
14	Copper washer (1/8")	015-005-S	1
15	Double screw (1/8")	187-001-S	1
17	Solenoid valve	160-0871-S	1
18	T fitting F+M+F (1/4")	148-194-S	1
19	Double screw con-cil (1/4")	187-006-S	1
20	Rilsan pipe d.8	089-0705-S	5
21	Rilsan pipe d.6	089-0605-S	1
22	15 bar pressure gauge	206-020-S	1
23	Straight quick coupling F (1/8") for pipe d.6	148-5765-S	1
24	Air filter clogging signaller	257-030-S	1
25	Double screw (1/4")	187-005-S	1
26	Quick coupling 90° (1/8") for pipe d.8	148-8001-S	1
27	Sintered silencer (1/4")	267-401-S	1
28	Square head plug (1/4")	106-025-S	1

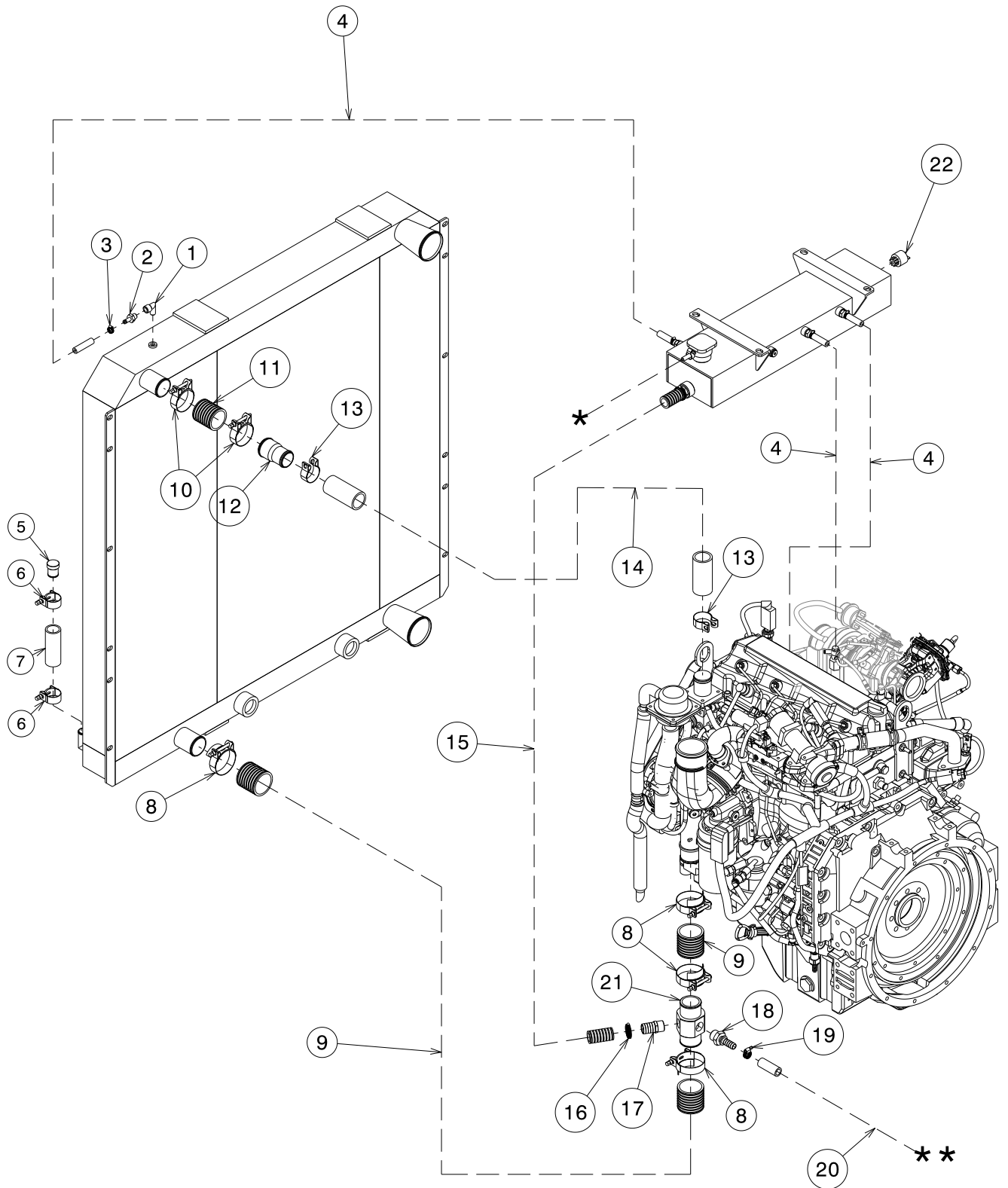



PARTS LIST

Motocompressor – D425T4F

PARTS LEGENDA: Cooling system

Tab. 09.5

POSITION	DESCRIPTION	PART No.	QUANTITY
1	90° M+F fitting (1/4")	148-143-S	1
2	M fitting (1/4") d.8	148-198.2-S	1
3	Pipe clamp 10x16	149-007-S	1
4	Anti-oil pipe for fuel 15x8	089-120-S	3
5	Aluminium cap	106-15400-S	1
6	Clamp SA 34-37	149-308-S	2
7	Calorflex pipe	089-009.5-S	1
8	Clamp SA 59-63	149-310-S	4
9	Pipe d. 51x61	089-008-S	1
10	Clamp 55-59	149-312-S	2
11	Pipe d. 48x58	089-0075-S	1
12	Reduction 48 to 42	190-603838-S	1
13	Clamp 40-43	149-309-S	2
14	Calorflex pipe d.42x52	089-007-S	1
15	Calorflex pipe	089-009.5-S	1
16	Clamp 20-32	149-023-S	1
17	Fitting 3/4 M d.25	148-19970-S	1
18	Fitting 3/4 M d.16	148-19965-S	1
19	Pipe clamp	149-011-S	1
20	Pipe 23x16	089-12106-S	1
21	Water pump fitting	148-69700-S	1
22	Level sensor	---	1
*	Drain on bottom frame		
**	To cooling block device		

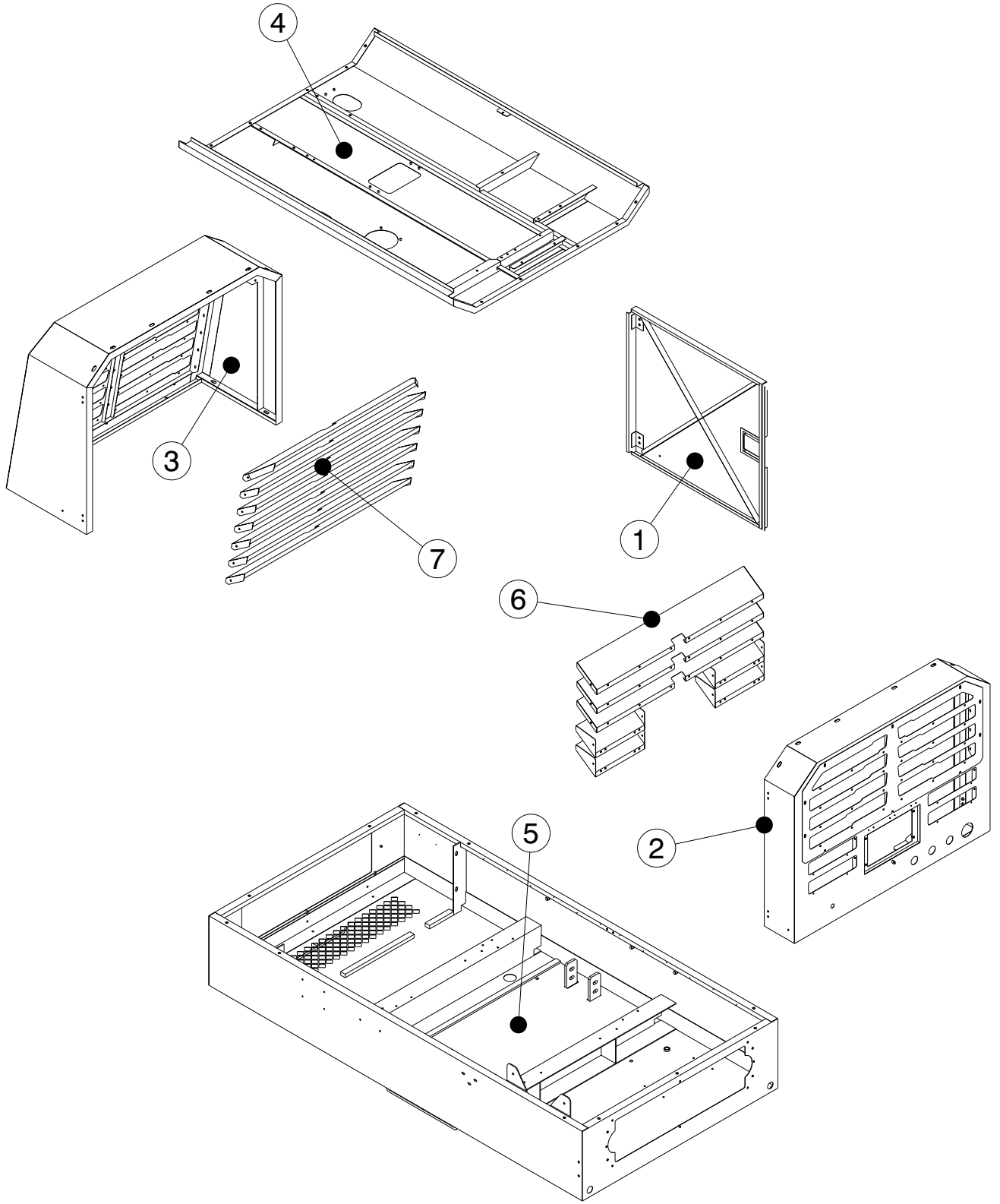



PARTS LIST

Motocompressor – D425T4F

PARTS LEGENDA: Soundproofing kit

Tab. 11

POSITION	DESCRIPTION	PART No.	QUANTITY
1	Side doors soundproofing kit	204-34662022-S	1
2	Front canopy soundproofing kit	204-3466203-S	1
3	Rear canopy soundproofing kit	204-3466204-S	1
4	Upper canopy soundproofing kit	204-3466205-S	1
5	Frame soundproofing kit	204-3466206-S	1
6	Front air intake soundproofing kit	204-3466200-S	1
7	Rear air intake soundproofing kit	204-3466201-S	1

ELGI

D 425T4F
D 400T4F

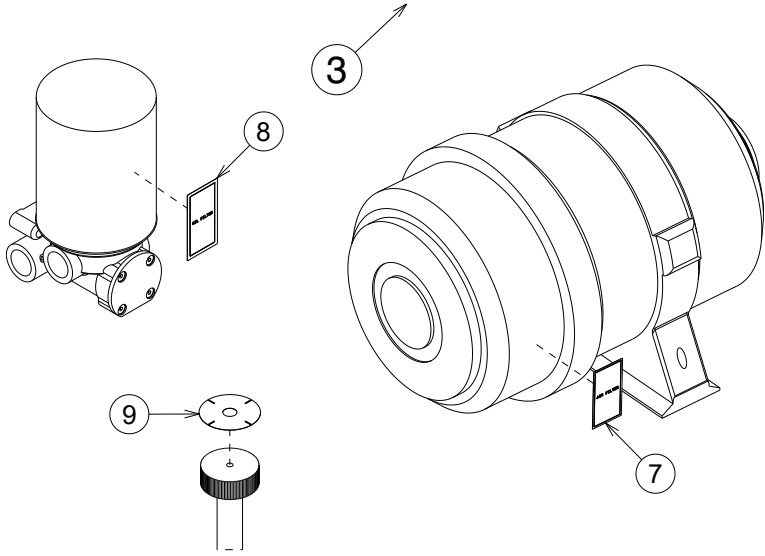

7 bar 100 psi | 10 bar 150 psi

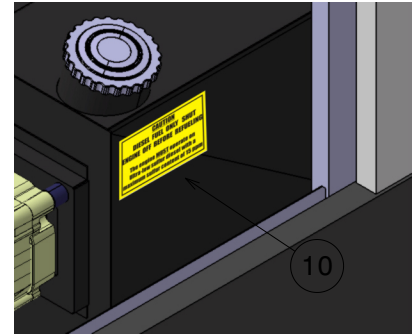

ELGI

MODEL	
YEAR / MFG	
WEIGHT (lbs)	
PRESSURE (psi)	
SERIAL NO.	
EXCLUSIVELY DISTRIBUTED IN NORTH AMERICA BY:	
ELGI	ROTAIR
ELGI PORTABLE COMPRESSORS T: 704 523 4123, www.elgi.us	ROTAIR S.P.A. 12023 - CARAGLIO (CN) - ITALY 238-149648



<p>6</p> <p>⚠ DANGER</p> <p>Hazardous Voltage. Presence of 24V DC voltage. Repairs and/or adjustments can cause severe injury or death.</p> <p>⚠ Crush Hazard. Moving parts can crush feet or hands.</p> <p>⚠ Ensure Guards. Ensure guards are in place before operating the equipment.</p> <p>⚠ Qualified Personnel. Service operations must be performed only by qualified personnel.</p>	<p>⚠ WARNING</p> <p>Do Not Remove. Do not remove caps, plugs or other components unless compressor is operated or repressured.</p> <p>⚠ Relieve Pressure. Stop compressor and release all internal pressure before removing caps, plugs or other components.</p> <p>⚠ Corrosive Substance. Presence of corrosive fluids inside the equipment. Repairs for filling can cause severe injury.</p> <p>⚠ Hot Surfaces. CONTACT can cause severe burn injury. Do not touch hot surfaces.</p>	<p>⚠ CAUTION</p> <p>Read Manual. Read instruction manual before each operation with the equipment.</p> <p>NOTICE</p> <p>Starting Instructions</p> <ol style="list-style-type: none"> 1. Should the machine be started with a battery, ensure that the DC key switch is in the "ON" position completely closed for at least 5 seconds before repressuring the compressor. 2. In case of problems in starting, do not touch the rear backhoe lever. Press the compression manually.
---	---	---

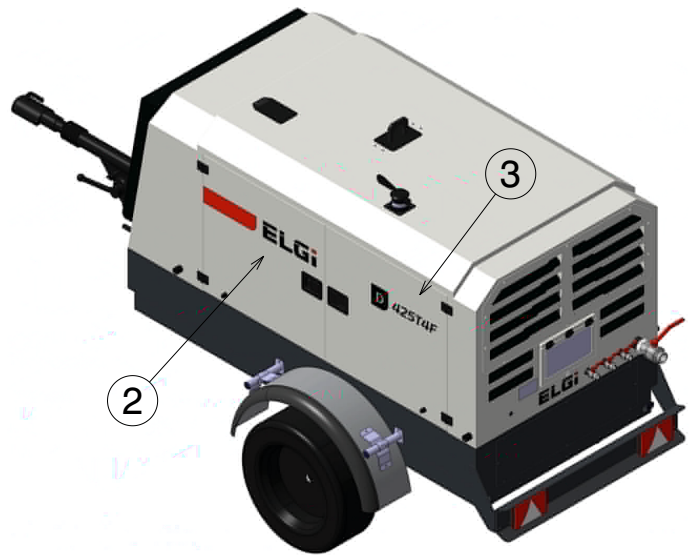

PARTS LIST

Motocompressor – D400T4F - D425T4F

PARTS LEGENDA: Decals

Tab. 10

POSITION	DESCRIPTION	PART No.	QUANTITY
1	Serial no. plate	238-14764-S	1
2	"ELGI Brand" decal	238-3274013-S	2
3	"D400T4F" decal	238-325869-S	2
	"D425T4F" decal	238-325872-S	2
4	"ELGI" black decal	238-3274017-S	1
5	"Burn hazard" plate	238-103201-S	2
6	Warnings sticker	238-01030-S	1
7	Air filter decal	238-001-S	1
8	Oil filter decal	238-002-S	1
9	Oil level check decal	238-003-S	1
10	"Caution diesel only" decal	238-097601-S	1
11	"Diesel Only" on fuel tank plug	238-097602-S	1
12	Double pressure – 7 / 10 bar (Double pressure version only)	238-0465-S	1

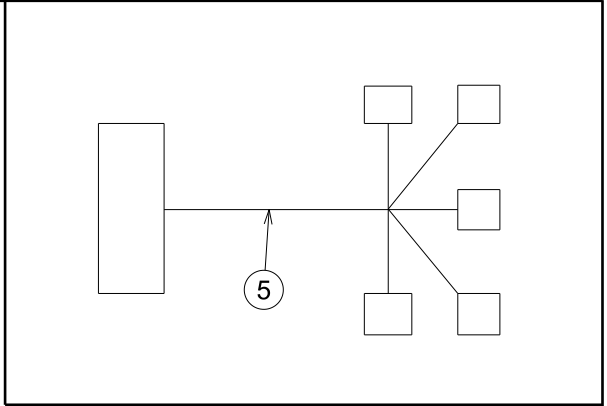
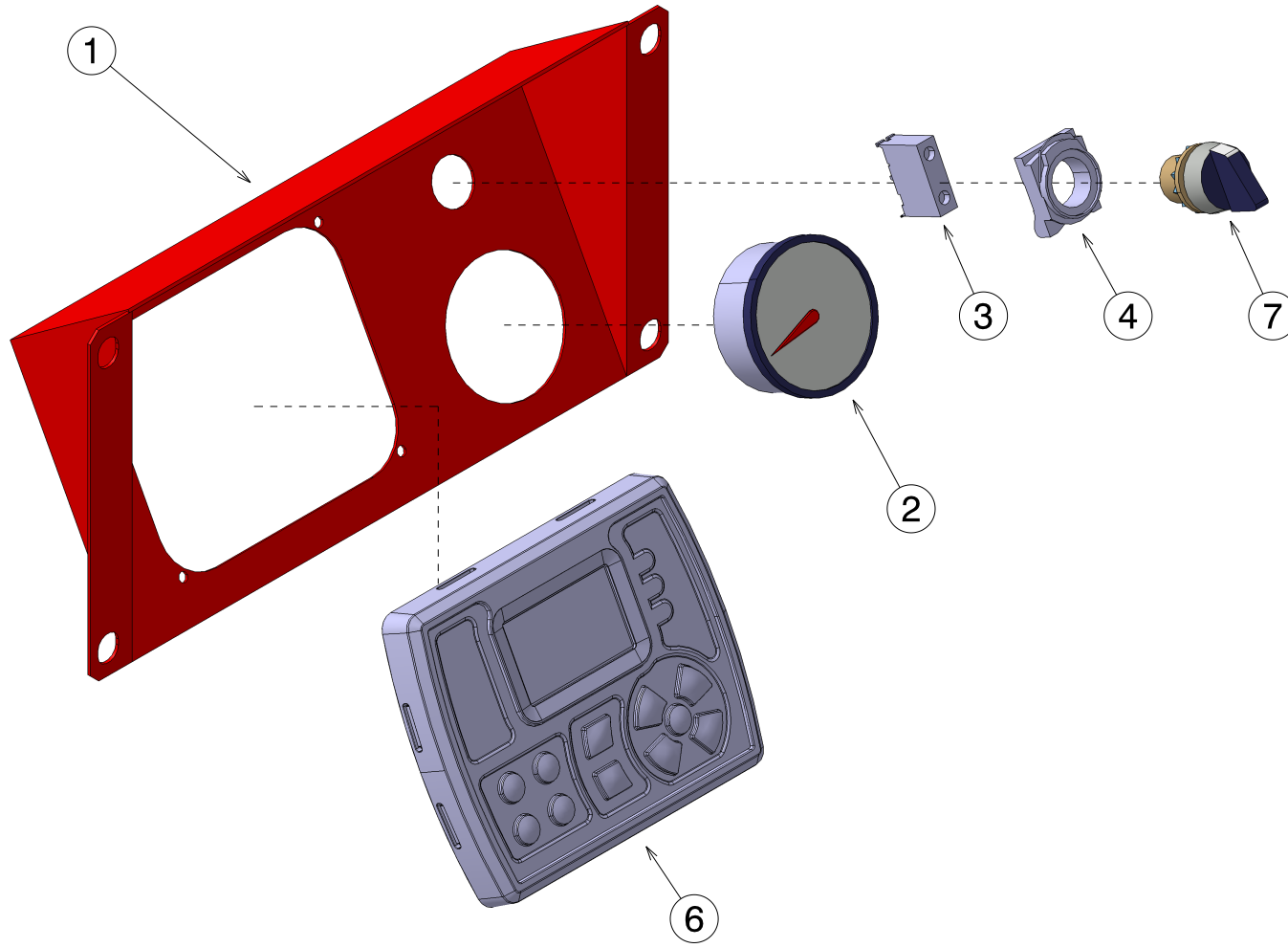



PARTS LIST

Motocompressor –D425T4F

PARTS LEGENDA: Control panel

Tab. 12

POSITION	DESCRIPTION	PART No.	QUANTITY
1	Control panel support	040-037520-S	1
2	15 Bar pressure gauge	206-020-S	1
3	Contact	127-375-S	1
4	Contact holder	127-376-S	1
5	Electrical harness	224-09238-S	1
6	Control panel	269-423720-S	1
7	2 position switch ON/OFF	249-022-S	1

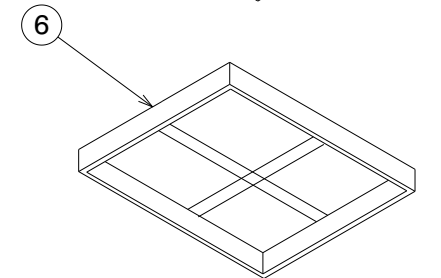
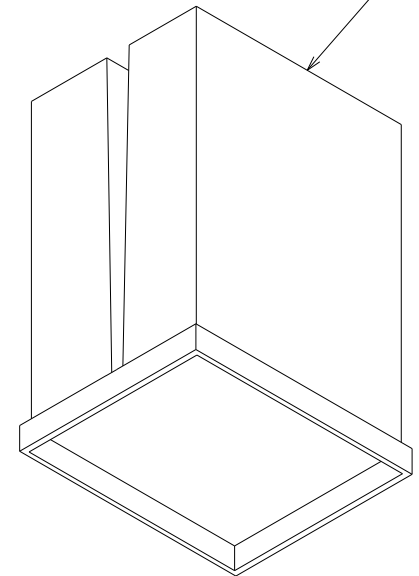
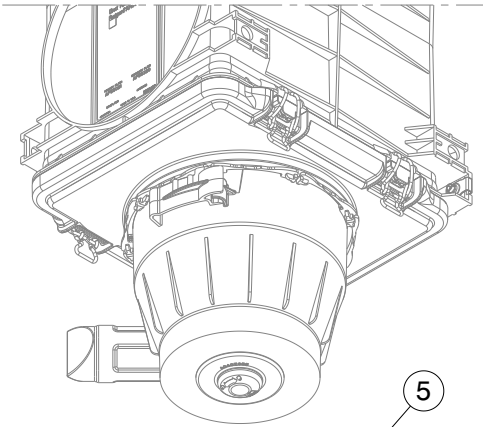
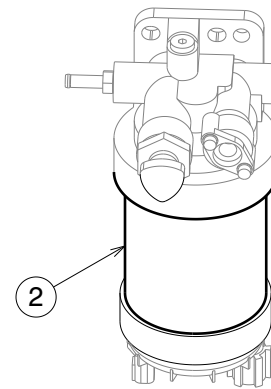
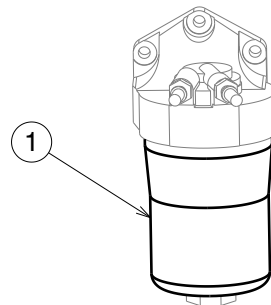
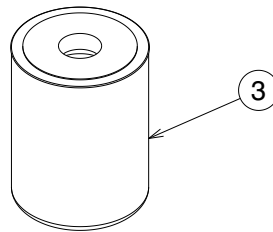
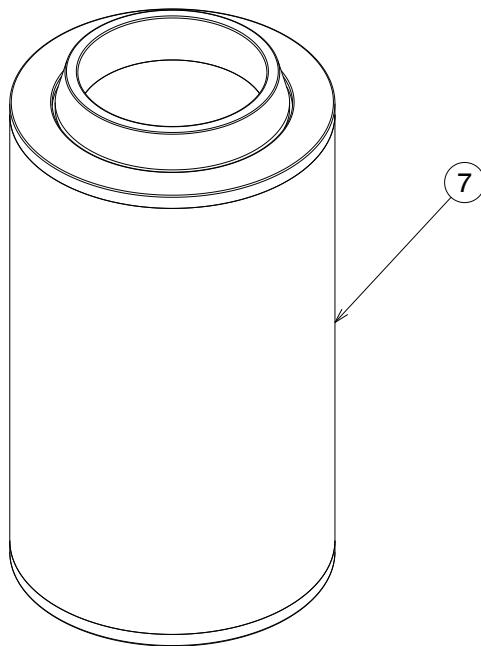
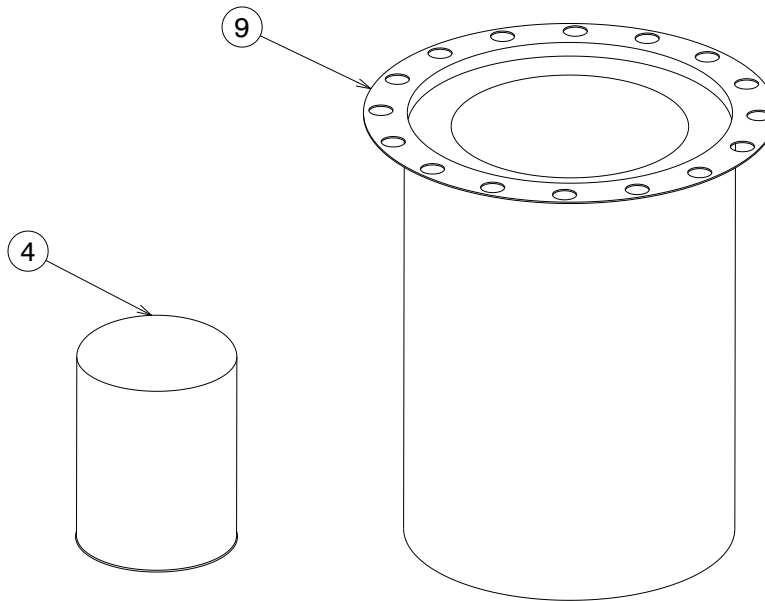
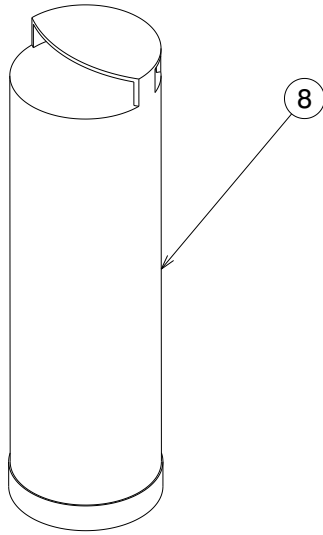



PARTS LIST

Motocompressor – D425 T4F

PARTS LEGENDA: Filters List

Tab. 13

REF	NAME	CODE	QUANTITY
1	Fuel filter	191-0902-S	8
2	Fuel pre-filter	191-0904-S	4
3	Compressor oil filter	099-0095-S	4
4	Engine oil filter	099-0920-S	8
5	Engine air filter 1	162-02600-S	4
6	Engine air filter 2	162-02602-S	4
7	Compressor air filter 1°	162-0080-S	4
8	Compressor air filter 2°	162-0081-S	4
9	Separator filter	157-1462-S	1