



**USER'S AND
MAINTENANCE MANUAL**

Date: 09/04/2024

Code MAN D185T4F ENG

Motor compressor : D185T4F

Revision 04



USER'S AND MAINTENANCE MANUAL

MOTOR COMPRESSOR

D *185T4F*





**USER'S AND
MAINTENANCE MANUAL**

Date:	09/04/2024
Code	MAN D185T4F ENG
Revision	04

Motor compressor : D185T4F

Dear customer,

Thanks for having purchased this ELGI motor compressor, which is designed and manufactured in compliance with high standards, in order to ensure high quality performance, as well as easy use and installation.

For any information, you can contact our customer service at the following address:.

ELGI PORTABLE COMPRESSORS

4610 Entrance Drive St A

Charlotte, NC 28273

704-523-4123

Portableservice@elgi.com

Portablesales@elgi.com



	USER'S AND MAINTENANCE MANUAL	Date:	09/04/2024
		Code	MAN D185T4F ENG
Motor compressor : D185T4F		Revision	04

FOREWORD

These service instructions have been drafted to facilitate the knowledge of the machinery purchased and its modes of use.

In drafting them, we have intentionally omitted the technical in-depth description of some operations linked to the motor and the axle, since such information is contained in the user's and maintenance of the respective manufacturers.

The service instructions contain indications of utter importance concerning the safe appropriate and cost-effective operation of the machine.

The compliance with said operations helps prevent potentially hazardous situations, additional costs and loss of time, increasing at the same time its life-span.

The service instructions and safety measures reported in this manual must be complied with by the user of the machinery.

Besides the service instructions and the accident prevention prescriptions which apply in the countries and places of installation, all the more general rules of safety at the workplace must be complied with.

It is therefore recommended to carefully read the instructions reported in this manual.

This manual cannot be disclosed, duplicated or copied without the previous authorization by the Manufacturer. Any lack of compliance with the above shall be pursued under the Law, in particular if the illicit action involves advantage for competing companies.





USER'S AND MAINTENANCE MANUAL

Date:	09/04/2024
Code	MAN D185T4F ENG
Revision	04

Motor compressor : D185T4F

TABLE OF CONTENTS

1	General	7
1.1	Definitions.....	7
1.1.1	Qualified personnel	7
1.1.2	Hazard.....	7
1.1.3	Hazardous area.....	7
1.1.4	Exposed person	7
1.1.5	Operator	7
1.1.6	Risk	7
1.1.7	Guard	7
1.1.8	Protection Equipment.....	7
1.1.9	Expected use	7
1.1.10	Reasonably expectable incorrect use	7
1.1.11	Component.....	7
1.1.12	Control Device.....	7
1.1.13	Safety interlock.....	8
1.1.14	Manufacturer	8
1.2	Machinery Identification	8
1.3	Harmonized technical standards.....	9
1.4	General description of the machinery	10
2	Technical features of the machinery	11
2.1	General technical characteristics	11
2.2	Technical characteristics of the compressor.....	11
2.3	Technical characteristics of the engine	12
2.4	Technical characteristics of the electric battery	12
2.5	Service temperatures	12
3	Symbols and warnings	14
3.1	Hazards.....	14
3.2	Forbiddances.....	15
3.3	Obligations and notices	16
3.4	General notices	16
4	Use of the machinery	18
4.1	Use allowed.....	18
4.2	Use not allowed.....	18
4.3	Residual risk.....	19
5	Levels and qualifications of the personnel	20
6	Safety provisions	20
6.1	Safety provisions concerning transport.....	20
6.2	Safety provisions concerning lifting	21
6.3	Safety provisions relevant to towing (for road-certified compressors only)	22
6.4	Prescriptions for the installation and parking of the motor compressor	23
6.5	Safety provisions concerning maintenance	25
6.6	Safety provisions concerning toolbox.....	26





USER'S AND MAINTENANCE MANUAL

Date:	09/04/2024
Code	MAN D185T4F ENG
Revision	04

Motor compressor : D185T4F

7 Machinery components.....	27
7.1 Chassis and axle	27
7.2 Body	27
7.3 Engine	27
7.4 Compression unit	27
7.5 Separator tank	28
7.6 Bell and flexible coupling.....	28
7.7 Control panel.....	28
8 Electrical equipment of the machinery.....	29
8.1 Operator's panel tools	29
8.2 Operator's panel pilot lamps.....	30
8.3 Electronic control board	31
8.4 Instructions for reading error messages and alarms in the DEEP SEA control board	36
8.3 Fuses.....	43
8.4 Lights (for road-certified version)	44
9 Hydraulic and pneumatic syStems	46
9.1 Hydraulic lubrication system	47
9.2 Pneumatic system.....	48
9.2.1 Automatic adjustment of the engine rpm	49
10 Provisions for the appropRiate utilization of the motor compressor	50
10.1 Before starting-up.....	50
10.2 Start-up.....	52
10.3 During the work cycle	53
10.4 Stop	53
10.5 After stopping the machine	54
11 Monitoring and testing of the machine	54
11.1 Monitoring and testing of engine speed	54
11.1.1 Control system of maximum engine speed.....	54
11.2 Monitoring and control of the air pressure of the compressor	54
11.3 Monitoring and control of air pressure minimum compressor.....	56
12 Safety device.....	57
12.1 Verification of the safety valve	57
13 Maintenance	58
13.1 Routine maintenance	58
13.2 Maintenance program	59
13.3 Values of tightening screws and bolts.....	61
13.4 Maintenance.....	62
13.4.1 Checking and cleaning air filters air intake	62
13.4.2 Control the electrical battery	63
13.4.3 Fuso replacement	64
13.4.5 Clean the radiator cooler.....	64





**USER'S AND
MAINTENANCE MANUAL**

Date:	09/04/2024
Code	MAN D185T4F ENG
Revision	04

Motor compressor : D185T4F

13.4.6	Percentage dosage of cooling liquid	64
13.4.7	Checking and cleaning oil recovery orifice.....	66
13.4.8	Drainage of the fuel tank.....	66
13.4.9	Replacing diesel filter and pre-filter.....	67
13.4.11	Control of locking wheel bolts	67
13.4.12	Oil filter replacement compressor	68
13.4.13	Replacement of compressor oil.....	69
13.4.14	Checking the oil mist separator.....	69
13.4.15	Replacement of the oil separator filter	70
13.4.16	Engine control and maintenance	70
14	Spare parts	70
15	Faults and troubleshooting	71
16	Disposal, elimination, disposal of the machine	73
16.1	Instructions for dismantling	73
17	Eliminating the machine	73
18	Waste management	74
18.1	Special waste	74
18.2	Toxic and hazardous waste	74
18.3	Temporary storage	74
18.4	Features of the containers	74
18.5	Registration requirements	74





USER'S AND MAINTENANCE MANUAL

Date:	09/04/2024
Code	MAN D185T4F ENG
Revision	04

Motor compressor : D185T4F

1 GENERAL

1.1 Definitions

The most significant definitions contained in this manual are reported hereinafter

1.1.1 QUALIFIED PERSONNEL

"Qualified personnel" are those personnel who are familiar with the rules for installation, assembly, repair and servicing of the machinery and who are provided with the specified technical qualification, such as e.g.:

Technical training authorizing to operate in compliance with the safety standards as related to the hazards the presence of electric current, pressure circuits, etc. may involve.

Technical background or - in any case - specific training relevant to the user's and maintenance procedures of the machinery in safety conditions.

Training in the basic first-aid activities.

1.1.2 HAZARD

A potential source of injury or damage to health

1.1.3 HAZARDOUS AREA

Any area within and/or in proximity of machinery where the presence of a person constitutes a risk for the health and safety of said person.

1.1.4 EXPOSED PERSON

Any person being fully or partially in a hazardous area

1.1.5 OPERATOR

The person/people charged to install, operate, adjust, clean, repair or move a Machinery or perform its maintenance.

1.1.6 RISK

Combination of the likelihood and severity of an injury or damage to health which may arise in a hazardous situation.

1.1.7 GUARD

Part of the machinery utilized to ensure protection by means of a material barrier.

1.1.8 PROTECTION EQUIPMENT

Device (different from a guard) which reduces the risk, by itself or associated to a guard.

1.1.9 EXPECTED USE

The use of the machinery in compliance with the user's information.

1.1.10 REASONABLY EXPECTABLE INCORRECT USE

The use of the machinery in a different way than the one indicated in the user's instructions, but which may derive from the easily expectable human behaviour.

1.1.11 COMPONENT

A constituent part of the electrical/pneumatic equipment, usually specified by its function, but used in various applications.

1.1.12 CONTROL DEVICE

A device introduced in a control circuit and used to control the operation of the system (e.g. position sensors,



	USER'S AND MAINTENANCE MANUAL	Date:	09/04/2024
		Code	MAN D185T4F ENG
Motor compressor : D185T4F		Revision	04

manual control switches, relays, electro-magnetic control valves).

1.1.13 SAFETY INTERLOCK

Mechanical, electrical or other device whose purpose is to prevent the parts of the machinery from operating in specified conditions (generally, until the guard is closed)

1.1.14 MANUFACTURER

Physical or legal person who designed and/or develops machinery or partly-completed machinery which is subject of this directive and who is liable for the compliance of the machinery or partly-completed machinery with this directive as related to its marketing with his/her name or brand, or for personal use. In absence of a Manufacturer as defined above, the Manufacturer shall be considered the physical or juridical person who markets or puts into service machinery or partly-completed machinery.

1.2 Machinery Identification

The identification nameplate is attached on the motor compressor chassis.

Such nameplate reports the Manufacturer's data, the denomination of the machinery, the code and year of manufacturing.

For any requests for spare parts or actions by our technicians, please refer to the data reported in the nameplate; in particular the code number of the machinery must always be mentioned.

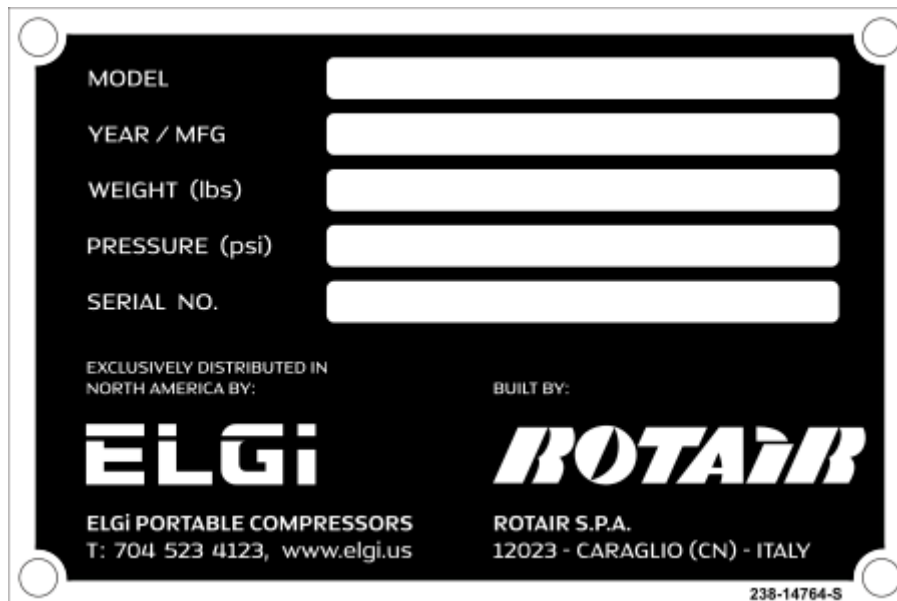

Figure 1.2-1 Nameplate of motor compressor D185T4F



1.3 Harmonized technical standards

The machinery has been designed and developed in compliance with the provisions contained in the technical standards reported herein under:

UNI EN ISO 12100	Safety of machinery -General design principles - Risk assessment and risk reduction.
UNI EN ISO 13857	Safety of machinery– Safety distances to prevent from reaching the hazardous areas with the upper or lower limbs.
UNI EN ISO 13850	Safety of machinery - Emergency stop system, functional aspects
CEI EN 62061	Safety of machinery - Functional safety of the programmable electrical and electronic control systems as related to safety
CEI EN 60204-1	Safety of machinery - Electrical equipment of the machineries. Part I: General rules.
UNI EN 983	Safety of machinery. Safety requirements relevant to systems and related components for hydraulic and pneumatic transmission. Pneumatics.
UNI EN 349	Safety of machinery - Minimum openings to prevent the crushing of parts of the human body.
D. LGS. January 27th 2010 no.17	Implementation of Directive 2006/42/CE relevant to machinery, which modifies directive 95/16/CE relevant to elevators.
UNI EN ISO 14121-1	Safety of machinery - Risk assessment. General principles
UNI EN ISO -TR 14121-2	Safety of machinery - Examples



Machine directive 2006/42/CE.

Article 7. Presumption of conformity and harmonized standards

1. The Member States deem that the machinery provided with the “CE” marking and accompanied by the CE declaration of conformity, whose elements are provided for in Annex II, Part 1, Section A, comply with the provisions of this directive.
2. The machinery manufactured in compliance with an authorized standard, whose reference has been published on the Official Journal of the European Union is assumed to be compliant with the essential health and safety requirements covered by such harmonized standard.
3. The Commission published the references of the harmonized standards in the Official Journal of the European Union.
4. The Member States shall take the appropriate measures to allow the social partners influencing - at national level - the development and control process of the harmonized standards.





USER'S AND MAINTENANCE MANUAL

Date:	09/04/2024
Code	MAN D185T4F ENG
Revision	04

Motor compressor : D185T4F

1.4 General description of the machinery

The machinery described in this manual is motor compressor D185T4F.

The motor compressor is a piece of machinery with the capacity of generating a given quantity of compressed air in l/m by using a diesel engine as primary energy.

The pneumatic energy finds applications in different fields of use, where "pneumatic" operation tools, accessories and equipment are utilized. For instance: demolition hammers, drilling hammers, vibrators, drilling machines, rammers, coating machines, etc.

Each of these tools/-accessories has its own consumption of compressed air, expressed in liters per minute.

The optimum coupling between the compressor and the tool is achieved when the compressed air consumption does not exceed 85% of the air generated by the compressor (furthermore, it must be taken into consideration that the quantity of compressed air required by the tool shall increase in time, proportionally to the wear of the tool itself).

The correct compressor-tool coupling ratio allows the machinery operating in optimum conditions, as appropriate to ensure long life-span at the highest performance.

An oversized tool - besides creating unfavourable conditions for the appropriate operation of the machinery - shall not develop full performance, since it cannot resort to the required quantity of compressed air.

This machinery has been designed to work at ambient temperature ranging from -10(14°F) and +40°C(105°F).



2 TECHNICAL FEATURES OF THE MACHINERY

The general technical characteristics of the machinery are reported hereinafter.

2.1 General technical characteristics

	D185T4F
DESCRIPTION	TECHNICAL VALUES AND DATA
Length (Body)	1835 mm – 72.20 inches
Width (Body)	1030 mm – 40.55 inches
Heigh (Body)	995 mm – 39.20 inches
Mass (Body)	850 kg – 1874 lbs
Compression system	Screw single-stage
Fuel tank capacity	90 lt – 23,75 gal

2.2 Technical characteristics of the compressor

	D185T4F (Standard version - 100 psi)
DESCRIPTION	TECHNICAL VALUES AND DATA
Service pressure	7 bars – 100 psi
Minimum pressure	5 bars – 73 psi
Max. pressure	8,5 bars – 123 psi
Rated payload at service pressure	5200 lt/min–185 CFM
Cooling typology	Specific oil for screw compressors (*)
Hydraulic system capacity	9 lt – 2,40 gal
Separator tank capacity	20 lt – 5,30 gal

(*) For the recommended oil see Paragraph 13.4.13

	D185T4F (Dual Pressure version – 100/150 psi)
DESCRIPTION	TECHNICAL VALUES AND DATA
Service pressure	7 bars – 100 psi 10 bars – 150 psi
Minimum pressure	5 bars – 73 psi
Max. pressure	8,5 bars – 125 psi 11,5 bars – 165 psi



2.3 Technical characteristics of the engine

DESCRIPTION	D185T4F TECHNICAL VALUES AND DATA
Engine brand	Kohler / Lombardini
Type	KDI-1903-TCR – Turbo - intercooler
Number of cylinders	3
Fuel	Diesel
Cooling	By liquid
Cooling system capacity	14 lt – 3,70 gal
Emissions	Stage IIIB - Tier 4 final
Engine oil tank capacity	9 lt – 2,40 gal
	D185T4F (Standard version - 100 psi)
Max. rotation speed	2450 r.p.m.
Min. rotation speed	1700 r.p.m.
	D185T4F (Dual Pressure version – 100/150 psi)
Max. rotation speed	2250 r.p.m.
Min. rotation speed	1700 r.p.m.

2.4 Technical characteristics of the electric battery

DESCRIPTION	TECHNICAL VALUES AND DATA
Rated voltage	12 Vcc
Capacity	100 Ah
Discharge current	750 A

2.5 Service temperatures

DESCRIPTION	TECHNICAL VALUES AND DATA
Minimum ambient temperature limit	-10°C [14°F]
Maximum ambient temperature limit	+40°C [105°F]
Humidity limits	≤ 50% (à +40°C-105°F)





**USER'S AND
MAINTENANCE MANUAL**

Date:	09/04/2024
Code	MAN D185T4F ENG
Revision	04

Motor compressor : D185T4F

NOTES: _____



3 SYMBOLS AND WARNINGS

The pictograms and main warning for the operators are reported herein under and indicated by the following denominations and symbols:

3.1 Hazards

**WARNING**

The pictogram calls the attention of specific provisions in order to prevent damage.

**WARNING FOR ELECTRICAL HAZARD**

The pictogram calls the attention of specific provisions in order to prevent damage.

**WARNING FOR CRUSHING HAZARD**

The pictogram calls the attention on a likely hazardous situation with risk of crushing the upper limbs.

**WARNING HAZARD OF ORGANS IN MOTION**

The pictogram calls the attention to the hazard of organs in motion.

**WARNING ON RISK OF SCALDING OR HAZARD DUE TO HIGH-TEMPERATURE ELEMENTS**

The pictogram calls the attention on the hazard of high-temperature elements and risk of scalding.



**WARNING:
OVERHANG
ING LOADS**

OVERHANGING LOAD WARNING

The pictogram calls the attention to the hazard due to the presence of overhanging loads

**WARNING OF THE PRESENCE OF PRESSURE VESSELS**

The pictogram calls the attention to the presence of pressure vessels.

3.2 Forbiddances

**FORBIDDANCE TO REMOVE THE PROTECTION EQUIPMENT AND THE GUARDS**

The pictogram calls the attention on the forbiddance to remove protection equipment such as fixed, movable, interlock guards or to tamper with photocells or photocell barriers.

**FORBIDDANCE TO PERFORM CLEANING OR MAINTENANCE WHEN THE MACHINERY IS IN MOTION**

The pictogram calls the attention on the forbiddance to perform cleaning or maintenance operations with organs in motion.

**FORBIDDANCE TO TRANSIT UNDER OVERHANGING LOADS**

The pictogram calls the attention on the forbiddance to transit under overhanging loads.

**FORBIDDANCE TO START THE MACHINERY WHEN THE HOOD IS OPEN**

3.3 Obligations and notices

**NOTICES**

This symbol recommends to consult the manual before undertaking a given action.

**OBLIGATIONS TO USE THE PPE (PERSONAL PROTECTION EQUIPMENT)**

The pictogram calls the attention on the obligation to use the personal protection equipment.

**NOTICES**

This symbol highlights that the description involves significant parts, since they may cause severe mechanical and electrical damage and malfunctions if the relevant standards are not complied with. It is recommended to comply with the information contained in this manual and with the law provisions in force as related to health and safety at the workplace.

**HIGHLIGHTING OF THE HOOKING POINT TO LIFT THE MACHINERY.****OBLIGATION TO USE THE SUPPORT FOOT, THE PARK BRAKE AND WHEEL LOCKING WEDGES.**

3.4 General notices

This manual includes the user's and routine maintenance instructions of the machinery. Whenever it is not specified otherwise, the operational and maintenance actions are to be considered as "specialized", i.e. they can only be performed by a technician appointed to the purpose.

Before undertaking any operation on the machinery, carefully read this manual.

ELGI declines any responsibility for any operation performed in conflict with the contents of this document.

Before utilizing the machinery, carefully read this document and comply with the safety law, regulations and standards in force.

This manual and the annexed documents must be considered as an integral part of the machinery they refer to and must always accompany the machinery, even if the latter is transferred to another user. It is therefore appropriate to preserve them for further reference.

This manual and the annexed documents are specific for the machinery they have been drafted for.



Do NOT utilize this manual and the annexed documents to run operations on similar machinery, of the same brand or typology.

	USER'S AND MAINTENANCE MANUAL	Date:	09/04/2024
		Code	MAN D185T4F ENG
Motor compressor : D185T4F		Revision	04

ELGI is available to its Customer for any further information. Please report the information (type of machinery, model and code) contained in the machinery identification nameplate. All the specific data not indicated in the text are mentioned in chapter "Technical characteristics of the Machinery" as well as in the technical annexes of this user's and maintenance manual.

This manual thoroughly describes:

- The information relevant to towing, lifting and parking of the machinery;
- The general rules and recommendations useful for routine and extraordinary maintenance;
- The modalities to identify and order the spare parts.

Remark: the instructions for the appropriate use of the engine are described in the manual drafted by the engine manufacturer.

This manual must be preserved with care, in its folder, far from sources of humidity, heat and sun rays, so that it can be consulted at any time by both the personnel appointed to the use and by those who need to perform routine and extraordinary maintenance.

This machinery has been exclusively designed and manufactured to deliver compressed air in the conditions stated by the Manufacturer. Every other utilization not mentioned in the "expected uses" shall relieve the manufacturer from any liabilities, which will be at full charge of the user.

"Approved purpose" assumes compliance with the provisions reported hereinafter and related to the appropriate use and maintenance, as well as to the transport of the unit.

All the accident prevention regulations and standards in force need to be complied with as well, besides complying with the general rules in terms of safety and occupational medicine which are governed by the legislation in force.

The manufacturer declines any responsibility in case of changes made on the machinery without its authorization.

Before commissioning, the buyer must ascertain that ANY equipment or machinery, components and protection installations that are not part of the supply of this machinery comply with Machine Directive 2006/42/CE and to the other applicable European Directives (2006/95/CE - 2004/108/CE, etc.).

4 USE OF THE MACHINERY

4.1 Use allowed

The machinery described in this manual is motor compressor D185T4F.

The machinery is allocated to work outdoor.

The motor compressor is a piece of machinery with the capacity of generating a given quantity of compressed air in l/m by using a diesel engine as primary energy.

The pneumatic energy finds applications in different fields of use, where "pneumatic" operation tools, accessories and equipment are utilized. For instance: demolition hammers, drilling hammers, vibrators, drilling machines, rammers, coating machines, etc.

Each of these tools/-accessories has its own consumption of compressed air, expressed in litres per minute.

The optimum coupling between the compressor and the tool is achieved when the compressed air consumption does not exceed 85% of the air generated by the compressor (furthermore, it must be taken into consideration that the quantity of compressed air required by the tool shall increase in time, proportionally to the wear of the tool itself).

The correct compressor-tool coupling ratio allows the machinery operating in optimum conditions, as appropriate to ensure long life-span at the highest performance.

An oversized tool - besides creating unfavourable conditions for the appropriate operation of the machinery - shall not develop full performance, since it cannot resort to the required quantity of compressed air.

This machinery has been designed to work at ambient temperature ranging from -10 (14°F) and +40°C(105°F).



WARNING: *It must be highlighted that the compressed air generated by this unit may contain some very fine traces of oil, therefore it is not appropriate to be utilized with those systems that call for fully oil-free air (e.g.: food processing and pharmaceutical industry, transports of flours and powders, cement, etc...).*

4.2 Use not allowed

It is not allowed to use the machinery for other processes than those which are mentioned in the section above. ELGI declines any responsibility as related to injuries or accidents due to lack of compliance with the specific provisions for use.

4.3 Residual risk



Avoid standing in front of the compressed air discharges. The direct exposure to the air jet may cause medium severity injuries because of the strength and speed of the compressed air.



The machine must operate outdoor, because of the presence of the engine and of the relevant exhaust gases.



It is strictly forbidden to operate the machine in indoor environments whose atmosphere is made of vapours or mixtures of corrosive or explosive gases.

When performing demolition, drilling, sandblasting activities or any other operation that generates dust the tool needs to be connected to the compressor through a pressure-resistant hose of sufficient length to keep the machinery away from the work area, thus preventing the clogging of both the exhaustion filters mounted on the unit and of the radiator for the cooling of the lubrication and cooling liquids. Even in this case, a good operator will locate the machinery leeseid versus the work area.

The machinery has been designed and built to work with the hood closed and - consequently - it is forbidden to keep it open when the engine is on, because - besides generation harmful sound emissions - the required internal ventilation would be interrupted, and this is instead indispensable for the appropriate operation of the compressor.

Make sure that the hood is closed, as well as the hinges located on the rear side of the motor compressor.

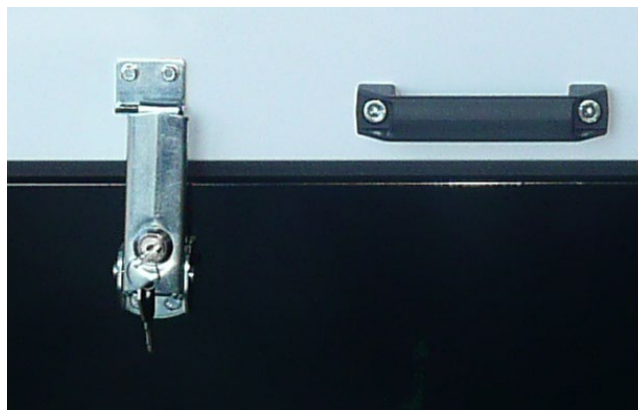

Figure 4.3-1 Engine compartment hood closing hinges

Even selecting the hoses to connect the machinery to the tool, make sure that they are sized as appropriate, taking into account their length, the volume of air which needs to pass through them and the service pressures: if the hoses show a too small diameter or excessive length, the air flow would interrupt, with subsequent loss of load and poor performance of the tool.

The hoses which convey compressed air to from the machinery to the tool, or to any device applied, is to be provided with a tap located at the end which is connected to the tool; the tap shall be held closed during the connection of the hoses to both the machinery and the tool in order to prevent an inappropriate opening of the tap on board the machine from generating strong flickering of the piping, which may cause injuries. Before disconnecting any hose, make sure there is no pressure inside.

5 LEVELS AND QUALIFICATIONS OF THE PERSONNEL

The actions on the machinery must be performed by qualified, trained and informed personnel only. "Qualified personnel" means people who - based upon their profession - have acquired experience and instructions as well as knowledge on the relevant standards and provisions on accident prevention and operational conditions. Such personnel, appointed by the machinery safety managers, must be able to perform the required operations as well as to recognize and anticipate the potential hazards.



Entrust the activities to appropriately trained or instructed personnel only; determine unmistakably the competences of the personnel as related to the fine tuning and to the maintenance and repair activities.

Define the responsibility of the operators appointed to run the equipment, also through accurate written provisions and authorize them to reject provisions by third parties if in conflict with the safety regulations and standards.

Make sure that the activities are performed by purposely-appointed personnel only.

The actions on the electrical equipment of the machinery can be performed - in compliance with the electro-technical regulations and standards - only by qualified electricians or by people with an appropriate level of competences in the electro-technical field.

The mechanical and pneumatic maintenance can be performed by the operators of the authorized workshops only.

6 SAFETY PROVISIONS

6.1 Safety provisions concerning transport

The motor-compressors which are not certified for towing need to be loaded onto another means of transport. The motor compressor shall have to be attached as appropriate to the floor of the means of transport in order to prevent and unbalancing of the load during transport.

The unit is shipped attached to a support appropriate for its handling by means of fork-lift trucks; such wooden platform facilitates the anchorage to the floor of the transport vehicle and prevents the load from sliding. For safe transport, operate as follows:

- 1) Locate the unit with the towing steer opposed to the cockpit of the transport vehicle.
- 2) Locate the towing bar as in Figure 6.1-1.
- 3) Make the ropes pass around the towing bar and tighten them by means of the winches provided with the means of transport.

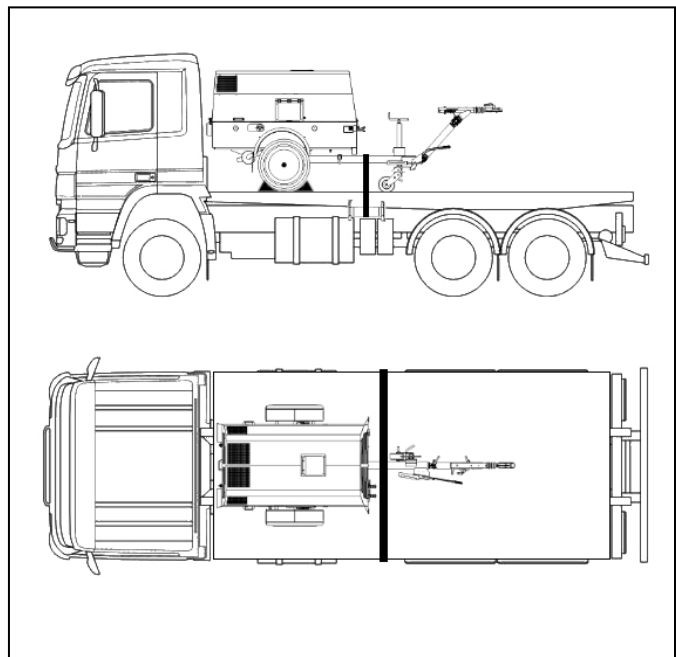

Figure 6.1-1 Instruction for towing in safe conditions

- 4) Set two wedges (Part A Figure 6.1-1) on each wheel, attaching them to the vehicle floor, in order to prevent the machinery from moving. Utilize wedges of appropriate sizes, both in height and in width.

- 5) Travel at moderate speed.



6.2 Safety provisions concerning lifting



Check the status of ropes and chains before starting the handling operations.



A purposely-allocated opening, protected by a rubber membrane, is obtained in the upper panel of the hood and allows for easy access to the lifting hook.

List of the operations for the safe lifting of the machine.

- 1) Make sure that the lifting device (crane, hoist, etc.) is of the appropriate payload to the weight of the unit and that it is maintained as appropriate.
- 2) In case of lifting installed on truck, use the side anti-tilting stabilizes of the means.
- 3) Attach the hook of the lifting means to the hooking point of the compressor (Figure 6.2-1).
- 4) Lift the unit slowly and without sudden pulls. In the side displacements, prevent the load from swaying excessively.



Figure 6.2-1 Lifting system of the machinery



The user must periodically check the efficiency of the lifting equipment and replace it if it results to be no longer appropriate or safe.

No other hooking and lifting systems are allowed except those which are provided with the machine.



This pictogram allows pointing out the hooking system to lift the machine.

- 5) Always check - before handling - that there are no moving parts that may fall. In such case, attach them as appropriate.
- 6) In any case, always make sure that the machine is solidly fixed to the rope and balanced as appropriate.
- 7) Communicate the start-up of the maneuver as appropriate.
- 8) Never leave the maneuver area with an overhanging load
- 9) Do not stand or walk under the overhanging load.



**WARNING
OVERHANGING
LOADS**

6.3 Safety provisions relevant to towing (for road-certified compressors only)

This paragraph concerns machines authorized for road circulation and therefore equipped with a regular homologation certificate.

For the appropriate towing of the motor compressor, comply with the following prescriptions:

- 1) Make sure that the large towing eyebolt or the ball coupler connection is compatible with the towing device located on the towing vehicle. Make sure that the vehicle is enabled to tow a weight equal to or greater than the one of the motor compressor you intend to tow.
- 2) Check the pressure of the tires.
- 3) Adjust the height of the eyebolt so that it corresponds to the one of the towing vehicle hook; this can be obtained by acting on the articulate joints of the steer, until the towing bar that supports the eyebolt is as horizontal as possible.
- 4) Solidly lock the articulations by means of the appropriate levers, make sure that there is no clearance between the joint teeth.
- 5) Insert the locking pins.
- 6) Hook the trailer to the vehicle, connecting also the safety cable.
- 7) Release the park brake.
- 8) Lock the foot, or the support wheel, in the highest possible position, making sure that the wheel cannot rotate on itself, and remove the wheel if required.
- 9) Connect the lighting system by introducing the motor

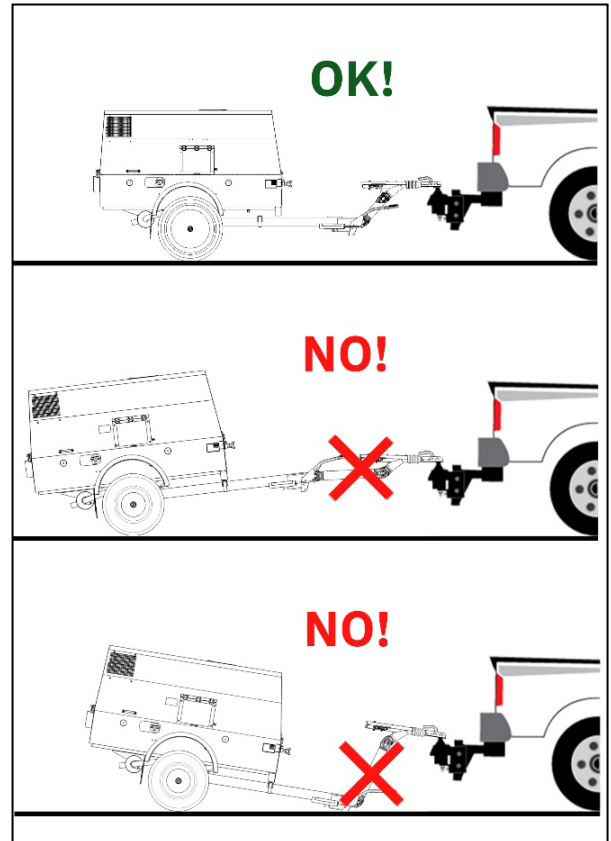

Figure 6.3-1 Instructions for safe towing

- 10) compressor plug into the purposely-allocated power outlet located on the vehicle and make sure that all the lights (position, turn, stop, number plate) are operational.
- 11) If the machinery is provided with inertial brake, the latter disengages automatically when maneuvering at reverse speed.
- 12) Periodically check the brakes and - if required - maintain them.

For the maintenance of the towing steer, of the axle and for the adjustment of the brakes, refer to the Manufacturer's manual enclosed to this documentation.



WARNING: To know the maximum speed for towing on the road, refer to the standards in force in the country where the towing is performed. On site or in a towing area, do not exceed the towing speed of 10 km/h.



6.4 Prescriptions for the installation and parking of the motor compressor

Before disconnecting the drawing vehicle, or from the lifting hook, adjust the height of the support foot (Part B Figure 6.4-1) or the pivoting wheel, so that the motor compressor is in horizontal position.

In case the machinery is on incline, locate the wedges (Part A Figure 6.4-1) provided with the machine, in front of or behind the wheels to prevent any displacements, which might also occur during the working stage.

Engage the park brake, if provided (Part C Figure 6.4-1). It is forbidden to operate with the machine hooked to the towing vehicle.

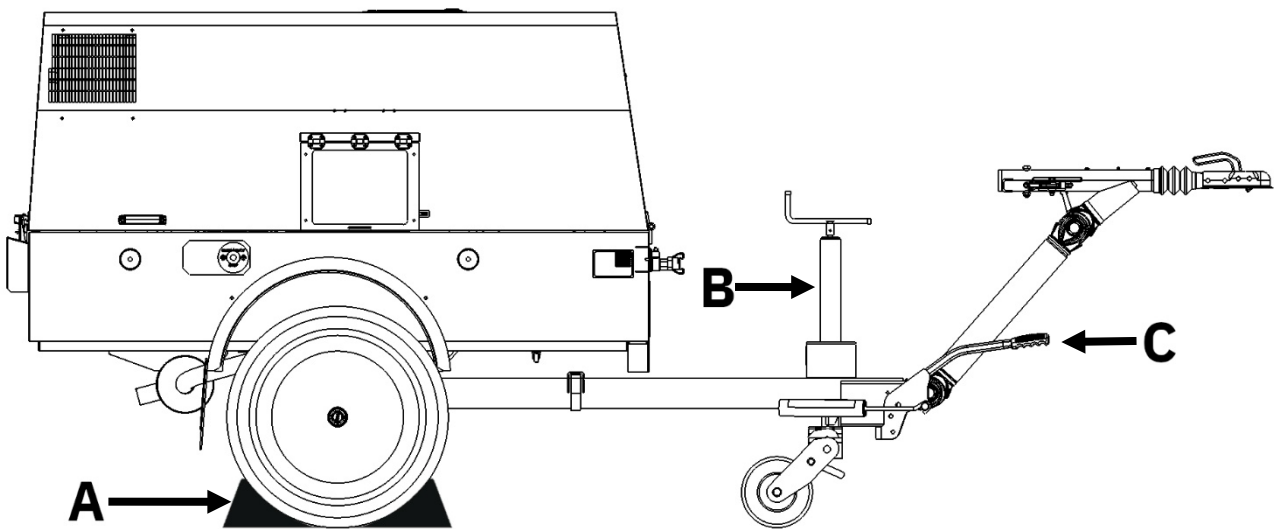

Figure 6.4-1 Instructions for parking and installation of the motor compressor



When parking, it is mandatory to use the support foot, of the hand brake and of the wheel locking wedges.

Only for the braked version is shown below the manual parking brake lever.



Figure 6.4-2 Lever of the manual park brake with release red push-button

6.5 Safety provisions concerning maintenance

In order to perform the maintenance operations in safety conditions, the following provisions need to be complied with:

- Control and maintenance operations must be carried out by qualified and specialized personnel who are familiar with the indications in this manual. By qualified and specialized personnel we mean people in possession of a suitable qualification and with a level of appropriate skills to the type of intervention and who have acquired experience and instructions on the prevention of accidents and on the procedures to be implemented to carry out maintenance interventions all the maintenance activities need to be performed after a safe stop of the machine and interrupting power supply to the engine;
- all the maintenance activities need to be performed after a safe stop of the machine and interrupting power supply to the engine;
- if the machinery is stopped during the maintenance and repair operations, it must be protected against accidental restart;
- in case of replacement of parts, the spare parts must be ordered at ELGI's customer service and must correspond to the technical standards defined by ELGI;
- the electrical equipment of the machinery must be periodically inspected. Any component's' faults must be immediately pointed out and replaced after careful assessment of their effectiveness and efficiency;
- keep the greatest possible cleanness during the maintenance operations, avoiding using flammable solvents;
- before restarting the machinery after maintenance or overhaul, make sure that all the guards and safety devices are restored and operational.
- never use water to extinguish the flames in case of fire (Figure 6.5-1).



Figure 6.5-1

After performing the maintenance operations, it is mandatory to restore the protections and - in particular - on the area of the cooling fan moving organs



6.6 Safety provisions concerning toolbox

The compressor can be equipped with a toolbox to put tools and/or objects inside the machine.

- Before putting any tools and/or object inside the toolbox, make sure the machine is allowed to cool down for 10 minutes.
- DO NOT to store containers with flammable or non-flammable liquid inside the toolbox.
- If you use the toolbox to store tools and other objects during the compressor handling and/or movement, make sure that the canopy is perfectly locked.

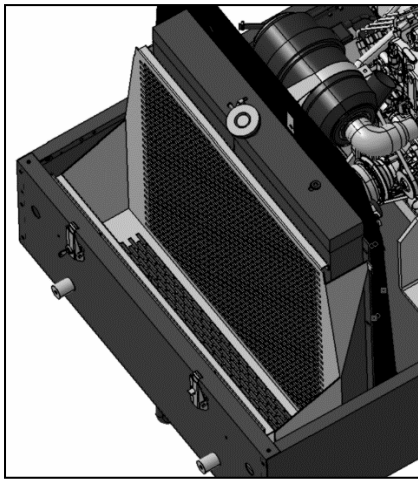

Picture 6.6-1 D185T4I-D185T4F Toolbox

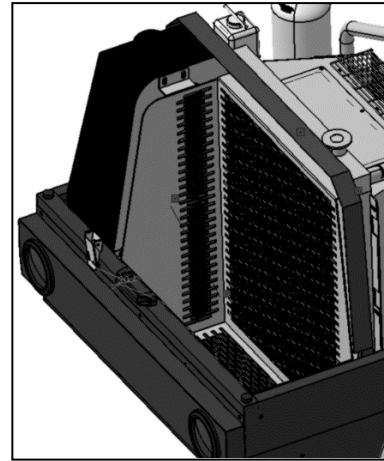

Picture 6.6-2 D90KA Toolbox



WARNING: the toolbox must not have any tool and/or any other object inside before the compressor starting, to grant a perfect air flow allowing the radiator cooling.



The toolbox max loading capacity is 100 lbs (45Kg).



The toolbox has to be used only for the storage and transport of tools and/or objects. **DO NOT** use it while the machine is working for operator's safety reasons.



WARNING: The toolbox, while the machine is working, can reach temperatures that could cause skin burns. Make sure you have properly aired the toolbox before storing any object.





USER'S AND MAINTENANCE MANUAL

Date:	09/04/2024
Code	MAN D185T4F ENG
Revision	04

Motor compressor : D185T4F

7 MACHINERY COMPONENTS

This unit D185T4F product range is a single-phase, silenced oil injection screw mobile motor compressor. The engine is internal-combustion, fuelled by diesel and is connected to the compressor by a flexible coupling.

7.1 Chassis and axle

The chassis is made from contoured and electrowelded sheet metal and is of load-bearing type. This chassis undergoes two paint coatings which ensure corrosion resistance and rust-proofing.

In the chassis there is the control panel which is protected by a transparent polycarbonate lid and which allows the compressed air pressure and the compressor oil temperature values to be read and allows a visual control of the warning lights each of which will indicate any anomalies of the machine element to which it is connected.

It is equipped with a drawbar which can be equipped with an eye hook or a ball coupling type hook. It consists of articulated, elements which permit correct attachment to the various pulling means.

The braking system includes the parking brake and the inertia braking system. Both act on the wheel-carrier drums of the axle.

7.2 Body

The galvanized metal sheet bodywork is treated with a special painting process that ensure excellent finish quality combined with maximum resistance to impact and rust. Special holes have been created in the elements forming the body, complete with baffles, which allow the cool air necessary for engine and compressor cooling to be sucked in from one side and the heated air to be expelled from the other side. These baffles have been carefully designed in terms of size and shape so as to allow the most efficient internal ventilation of the machine: it is advisable, therefore, to make sure that these openings are kept free and undamaged.

All the parts of the body have been treated with a special painting process which ensure excellent finishing quality together with maximum impact and rust resistance.

7.3 Engine

The unit is equipped with a Diesel engine whose features are described in Section 2.

As related to the user's and maintenance instructions, refer to the manual provided by the Manufacturer and enclosed to the documentation relevant to this machinery.

7.4 Compression unit

It is completely manufactured in the factory and consists of a central body (cylinder) inside which are fitted two screw rotors with asymmetric section, a male one with 5 lobes and female one with 6 lobes.

The cylinder is closed at the ends by two head sections which contain the bearings which bear the radial and axial loads created by the air compression. A series of channels, inside the cylinder and heads, undertake to deliver the oil to the various components. The distribution of the lubricant, serves to lubricate the bearings and to maintain a coating of oil between the rotors and the bearings themselves as well as the internal cylinder walls, thereby promoting compression resistance. Another important function of the oil injected between the rotors is that of absorbing the heat generated by the air compression.

The compressed air supplied by this compressor is free of any pulsations and compression comes about axially.

A "regulator" unit is mounted on the compression unit, the purpose of which is to regulate the quantity of air taken in according to the amount of air consumed. A double-stage filter mounted on the top of this unit ensure maximum purity of the suctioned air.





USER'S AND MAINTENANCE MANUAL

Date:	09/04/2024
Code	MAN D185T4F ENG
Revision	04

Motor compressor : D185T4F

7.5 Separator tank

Consists of a pressurized container, and due to its construction features it is exempt from the annual I.S.P.E.L. inspection and is supplied with a conformity certificate issued by the manufacturer. The identification and inspection details are impressed on a plate which is welded to the machine.

The lid features the following elements: safety valve for overpressure, a thermal switch which intervenes if the temperature inside the tank exceeds 100°C and valves which regulate the maximum and minimum pressure of the machine.

7.6 Bell and flexible coupling

The engine and the compressor are interconnected by a bell which ensure concentricity between the engine flywheel and the compressor shaft.

A large-size block joint with rubber pieces interspaced transmits power in a smooth and silent way without splitting.

The engine-compressor thus assembled is clamped to the frame with four flexible supports (silent-blocks) which completely absorb the vibrations it generates. A fan is splined to the engine shaft on the opposite side to the flywheel which generates large air displacement which cools the machine fluids and elements.

7.7 Control panel

The control panel layout, on the RH, was specifically designed so as to have all the controls within reach of a single person.

All the necessary instruments to control the unit are located on the control panel.



8 ELECTRICAL EQUIPMENT OF THE MACHINERY

WARNING: any action on the electrical system must be performed by qualified personnel.

8.1 Operator's panel tools

- 1) Pressure gauge;
- 2) Control board;
- 3) ON/OFF switch;
- 4) Up/down arrow keys;
- 5) Pressure switch;

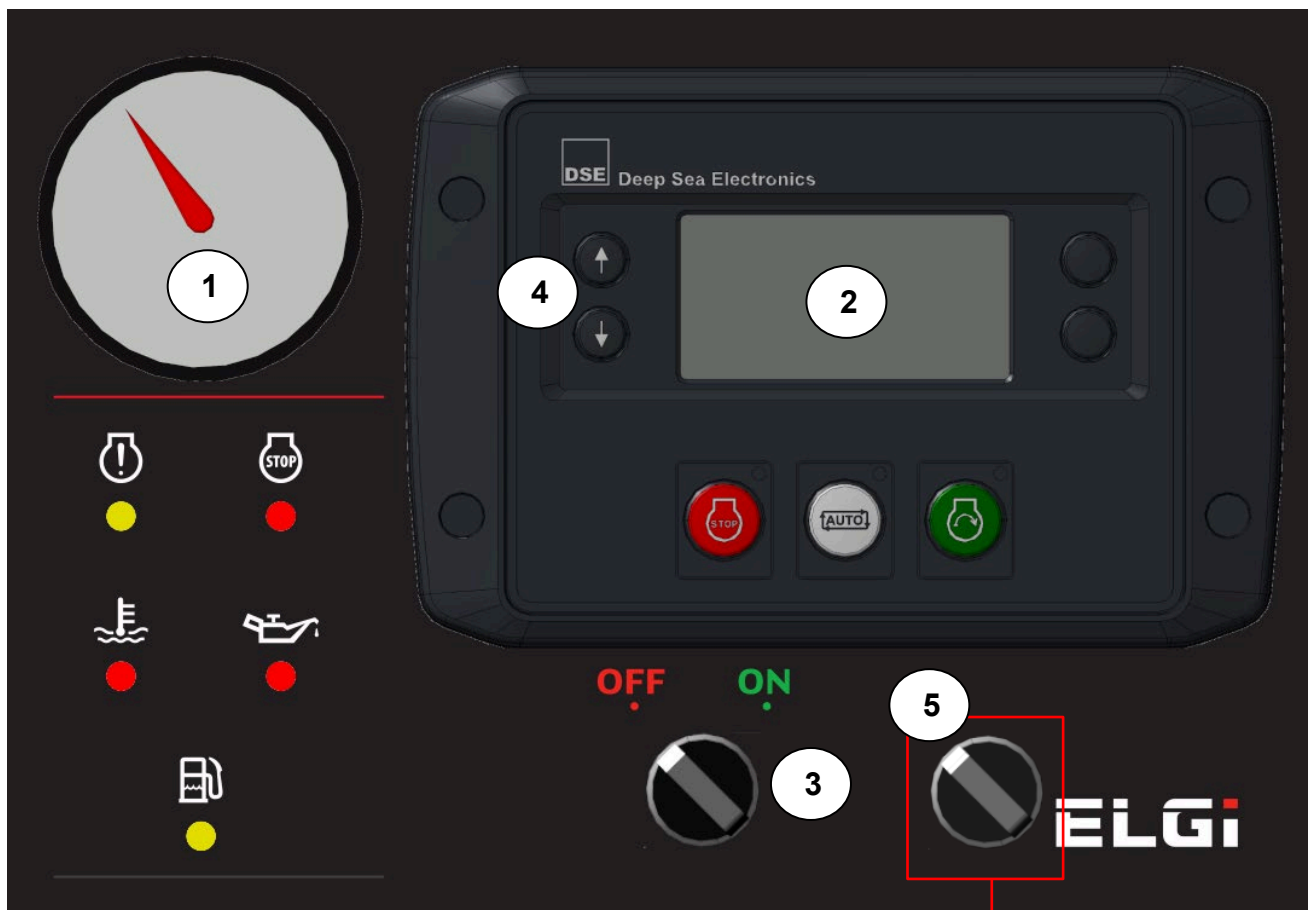







Figure 8.1-1 Instrument panel and control devices

DUAL PRESSURE Version



8.2 Operator's panel pilot lamps

PILOT LAMP	DEFINITION	FUNCTION	OPERATION TO BE PERFORMED
	HIGH TEMPERATURE LAMP	This pilot lamp highlights that the radiator cooling liquid have reached an excessive temperature	Immediately switch off the machinery and verify the following cases 1) check the liquid level in the radiator and clean it; 2) the cooling liquid pump does not operate as appropriate (contact ELGI customer service); 3) the liquid valve does not close or open at the right moment (replace); 4) if the cooling liquid is leaking, contact ELGI customer service; 5) the radiator is obstructed (contact ELGI assistance).
	ENGINE OIL PRESSURE LAMP	This pilot lamp highlights the insufficient pressure of the engine oil. The lamp is off when the engine oil is in pressure Pilot lamp lit: engine oil not in pressure.	The oil pilot lamp highlights the insufficient pressure of the oil. Such insufficient pressure may be caused by: 1) engine oil level check; 2) breakage of the delivery pump; 3) oil not reaching the delivery pump
	STOP ENGINE	This warning light lit when the engine control unit detects a serious malfunction.	STOP the engine immediately and contact ELGI assistance service.
	WATER IN THE FUEL	The fuel warning light lit when the engine sensor detects the presence of water in the fuel system.	STOP the engine immediately, empty the fuel tank and fuel system. Replace with new fuel.
	CHECK ENGINE	This light signals lit when the engine sensor detects a problem (a broken sensor, etc.)	The problem detected by the engine is of medium entity and allows the compressor to continue to be used; to identify the status of the problem, check the electronic control board.

8.3 Electronic control board

Switching on the panel with the ON / OFF switch (Figure 8.1 1 - N.3) turns on the Deep Sea electronic control board;

Below are the screens of the board which, in rotation of a.c. 7 seconds, will be shown on the display and related information.

You can manually scroll through the screens using the arrow keys **↑↓** (No.4 - Figure 8.1 1) on the board.

Status

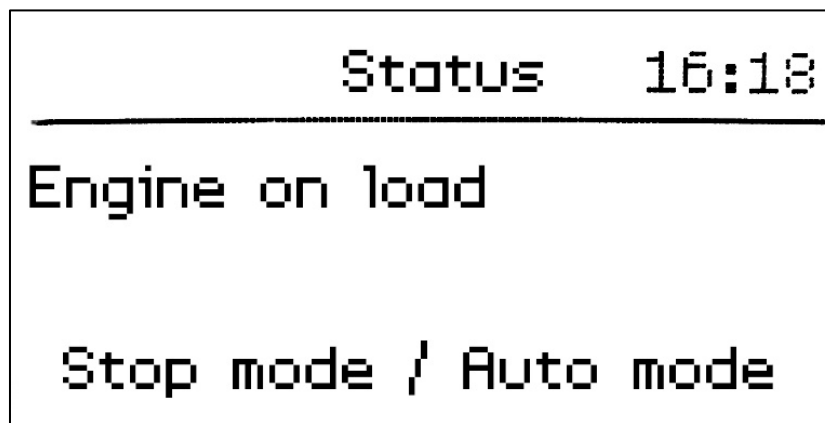

- Engine running: The engine is running and ready to work.
- Auto Mode: Displayed when the engine is under load.
- Stop mode: is displayed when the control board is turned on and the engine has not been started yet.

Engine speed RPM

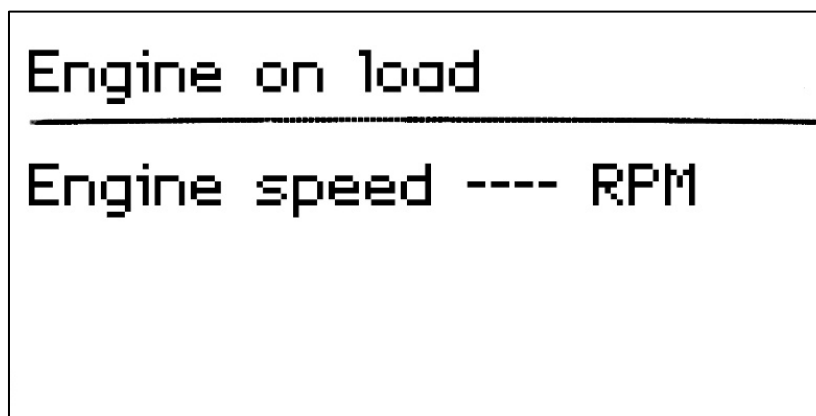

- Motor speed: displays the rev / min (rpm) of the motor.



Engine information

%	---- bar
Eng. Percen	Engine oil pres
---- rpm	---- C°
Engine speed	Engine cool

- Percentage of engine load
- Engine oil pressure
- Motor speed (rpm)
- Coolant temperature

Air pressure information

Ø	---- V
Start(s)	Battery
---- RPM	---- bar
Engine speed	Air pressure

- Start (s): number of engine starts
- Battery: Volt indication of the battery
- Motor speed (rpm)
- Air pressure: air pressure on exit tap / s



Engine running time

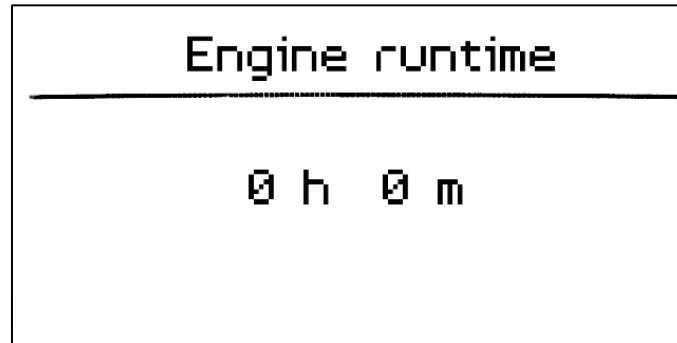

- Engine runtime: displays the hours and minutes of engine use.

Maintenance and replacement of air filter and engine oil filter

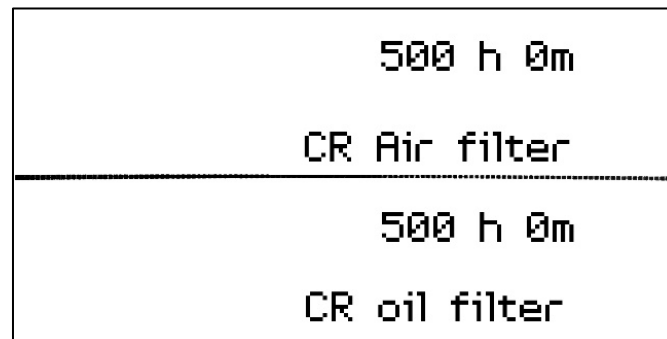

- Substitute air filter: Indicates how much time is left until the recommended replacement of the engine air filter.
- Substitute oil filter: Indicates how much time is left until the recommended replacement of the engine oil filter.

Fuel level

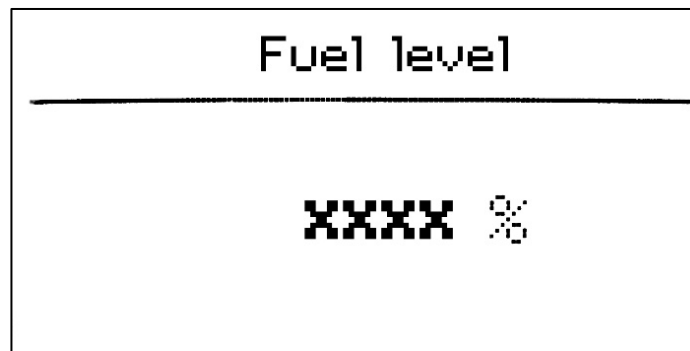

- Fuel level: indicates the percentage of fuel inside the tank.

STATUS



ATTENTION: The display of icons on the warning screen indicates an engine problem / warning; below you will find what they indicate.

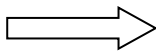

Problem / malfunction: STOP the engine immediately and call assistance

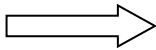

Fuel level below 10%: the engine will automatically stop afterwards c.a. 10min; should you continue to operate it will be possible to restart the machine, following the second shutdown, the tank will need to be refilled.

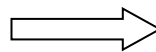

Activation of the Grid heater (Optional)

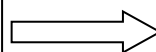

Available power: indicates that the engine is not delivering all available power (problem or malfunction)

Date:	09/04/2024
Code	MAN D185T4F ENG
Revision	04

Motor compressor : D185T4F



ATTENTION: In order to extend the “key on” time to 15 minutes it is necessary to press the  key 5 times;



to verify the correct activation of the extension of the 15 min “key on” period, the lights on the control board will flash as in the image below.

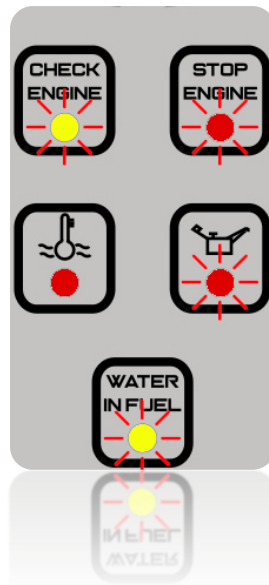

8.4 Instructions for reading error messages and alarms in the DEEP SEA control board

The display of errors and alarms (engine side and compressor side) can be done both with the engine running and the engine off.

ENGINE OFF

1. To enter the menu related to error codes and alarms it is necessary to power the engine electronic control unit;
2. With the ignition on (ON selector) press the hare button 6 times until the indicator lights light up



Lights on indicate the engine control unit is powered.



ATTENTION: If after pressing the hare button 6 times, the indicator lights do not light, press the green engine start button;

3. To scroll through the main menu, you must press the "up" or "down" arrow and hold it for 2 seconds to display the menu pages, to change the page, then press and hold the arrow until the page is changed.



4. If the arrow is pressed quickly scroll through the main menu pages

ENGINE RUNNING

When the engine is running, the motor circuit board is already powered from point 3

5. ERROR DISPLAY ENGINE ELECTRONIC CARD (ACTIVE DTC)

- Scroll through the pages as described in point 3 to the page "DTC Active"
- Within this page are displayed active errors (live) in the electronic engine board.
- These errors have a code + a small description



ATTENTION: It is important to enter this page to indicate to the assistance or to the motorist what are the active errors in the engine control unit



6. COMPRESSOR ALARMS + ENGINE ALARMS (ALARMS)

- Scroll through the pages as described in point 3 to the page "ALARMS"
- Within this page you will see active alarms (live) from the compressor side and general descriptions regarding engine alarms.



7. VIEWING LOG OF EVENTS

- Scroll through the pages as described in point 3 to the "EVENT LOG" page
- This page displays all the events that occurred during the use of the compressor (ignition, fuel reserve, engine errors, compressor errors).
- The log is the history of the warnings that appeared during the use of the compressor



Date:	09/04/2024
Code	MAN D185T4F ENG
Revision	04

Motor compressor : D185T4F

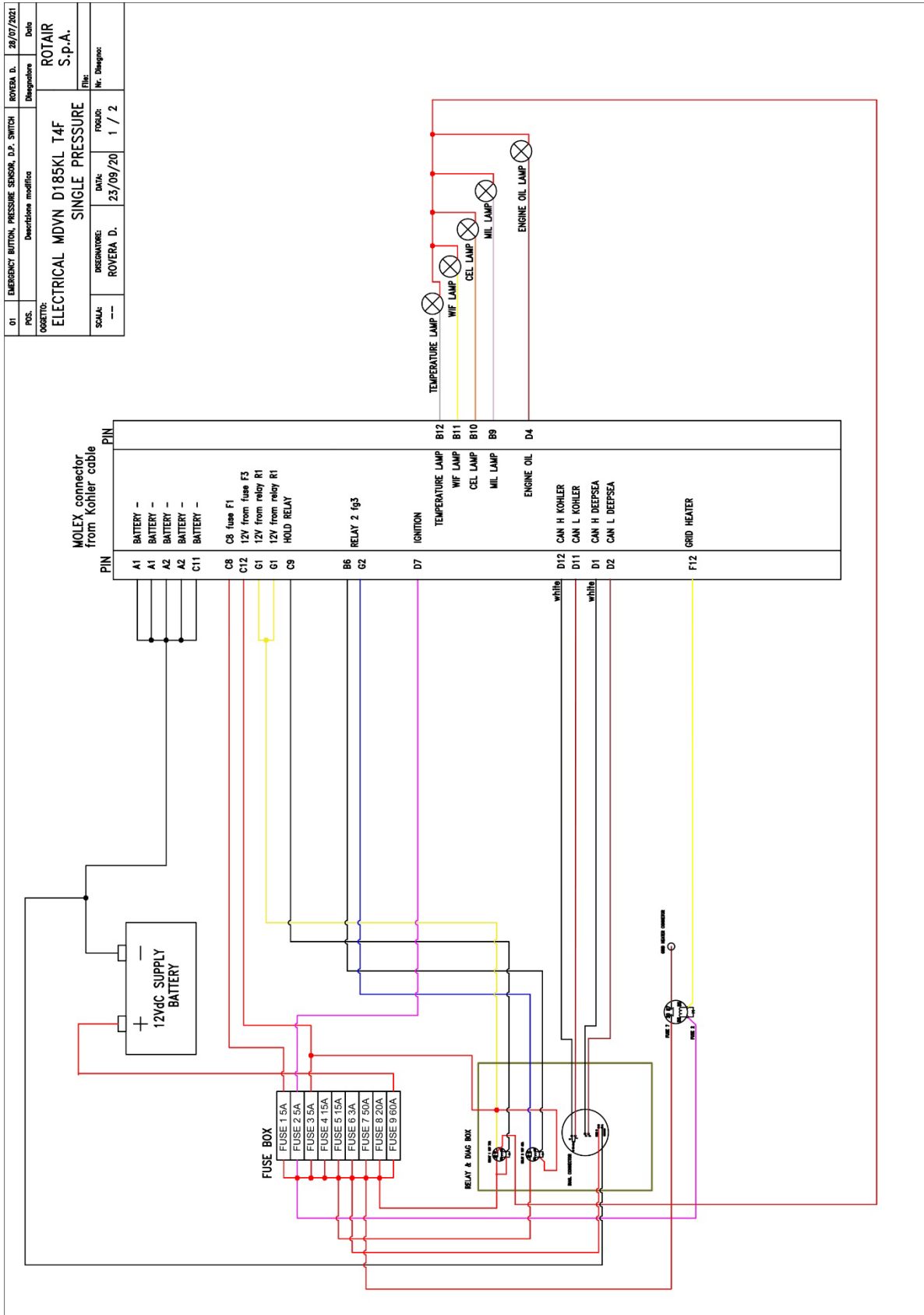

Motor compressor : D185T4F

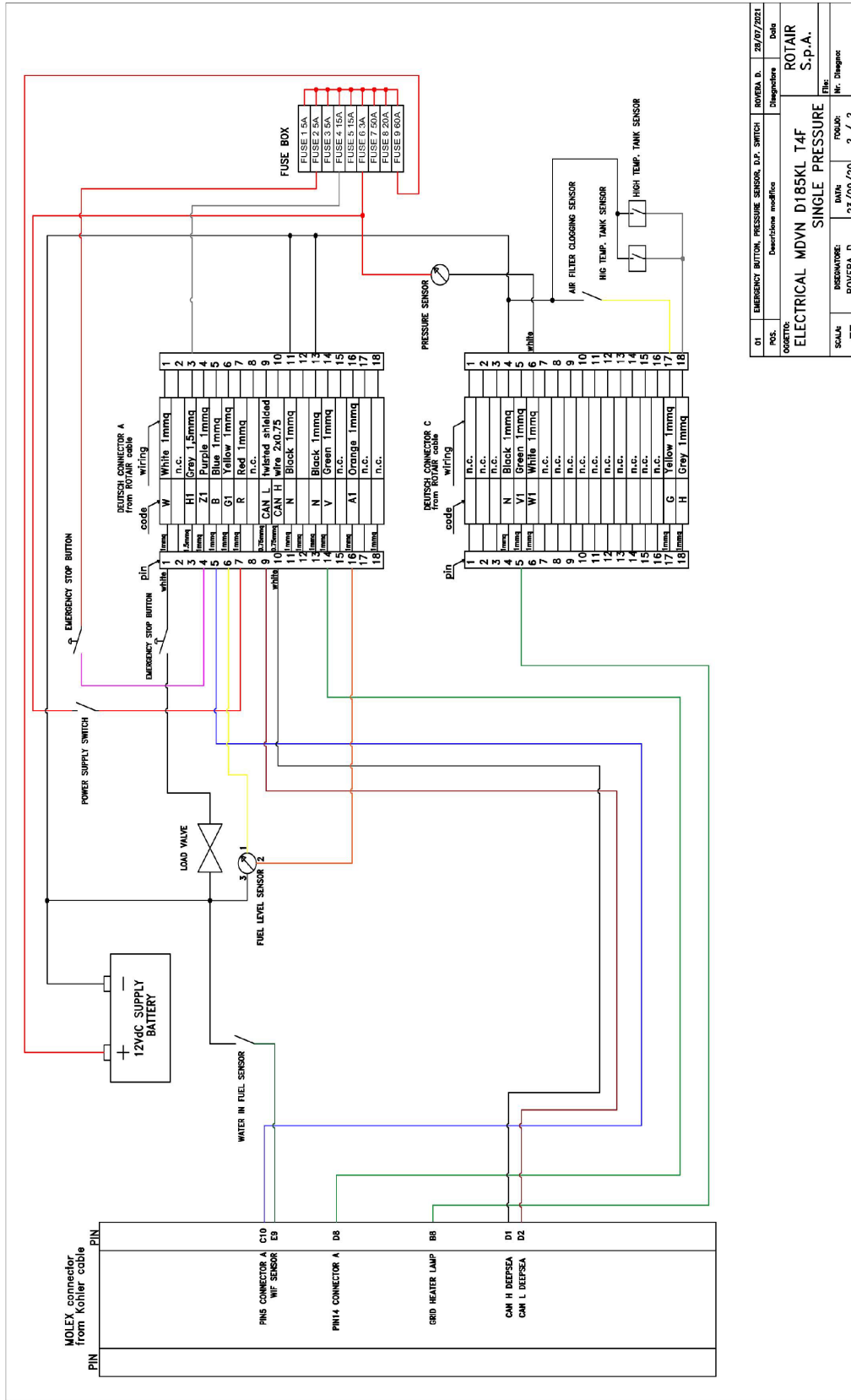

CI	EMERGENCY BUTTON	PRESSURE SENSOR	D.P. SWITCH	ROVERA D.	29/07/2021
pos.	Description modifica			Disegnato	Data
CODICE: ELECTRICAL MDVN D185KL T4F					
SINGOLA PRESSIONE					
SCALE	PROVA/PROVE	DATA	FOGLI:	File:	
---	ROVERA D.	23/09/20	2 / 2	Nr. Disegni:	

Figure 8.2-2 Diagram machine's electrical system D185T4F



Date:	09/04/2024
Code	MAN D185T4F ENG
Revision	04

Motor compressor : D185T4F

01	EMERGENCY BUTTON, PRESSURE SENSOR, D.P. SWITCH	ROVERA D.	28/07/2021
POS.	Descrizione modifica	Disegnatura	Data
OGGETTO:	ELECTRICAL MDVN D185KL T4F DUAL PRESSURE	ROTAIR S.p.A.	
SCALE:	ROVERA D.	DATA:	23/09/20
		FOLIO:	1 / 2
		Nr. Disegni:	

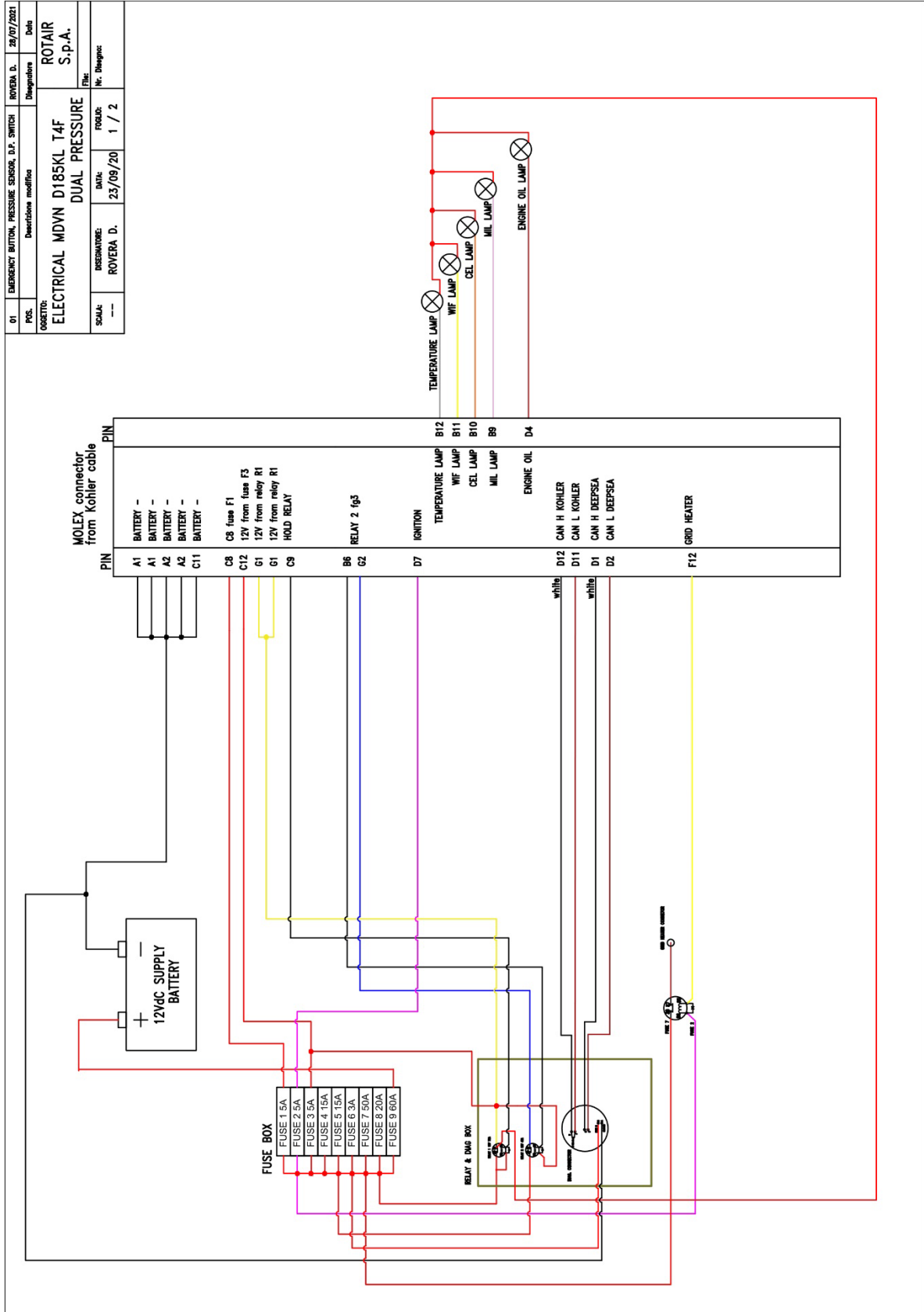

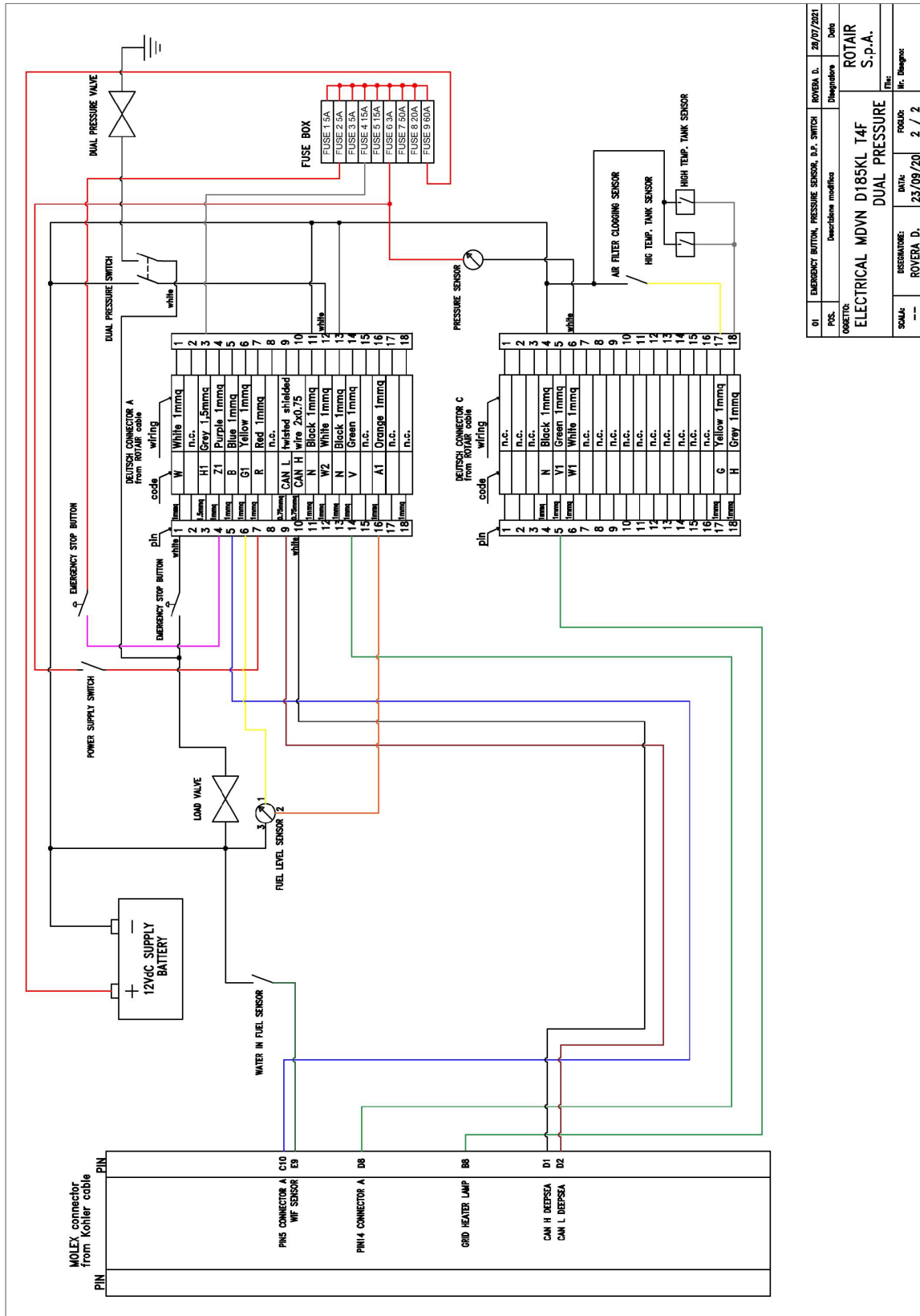

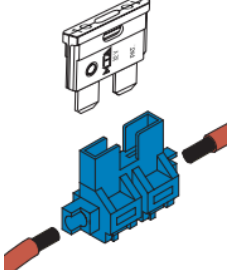

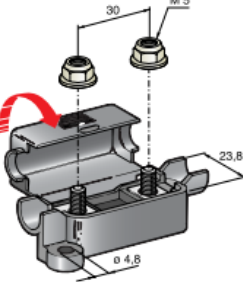

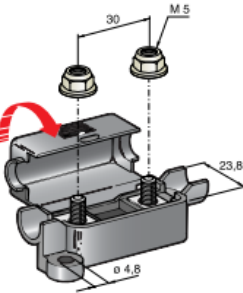

Figure 8.2-3 Diagram machine's electrical system D185T4F (Dual Pressure)



8.3 Fuses

The fuse is an electrical device which can protect a circuit or a device from over current.

The fuse consists of a cartridge provided by a thin lead wire through which the rated current of the circuit/element transits; this wire is the actual fuse, with a precise Amp load. In case of overcurrent, the filament melts and causes the circuit to open.

Fuse holder	Fuse	Description	Ampere
		Secondary fuse: device to protect against overcurrent which might damage the fuel solenoid	16 A
		Operator Panel Fuse: protection device against overcurrent that may damage the operation panel	40 A
		Protection device against overcurrent that could damage the engine glow plugs during warm.	40 A



WARNING: When replacing the fuses, we recommend always utilizing the sale type as indicated in this table and to follow the procedure reported in section 13.4.3 of the manual.

8.4 Lights (for road-certified version)



The electrical system is completed by the light wiring (Figure 8.4-3). This system is directly connected to the towing machine through an extension supplied with the motor compressor.

Rear lights:

- 1) Turn light
- 2) Position and stop light (stop detected by light intensity)

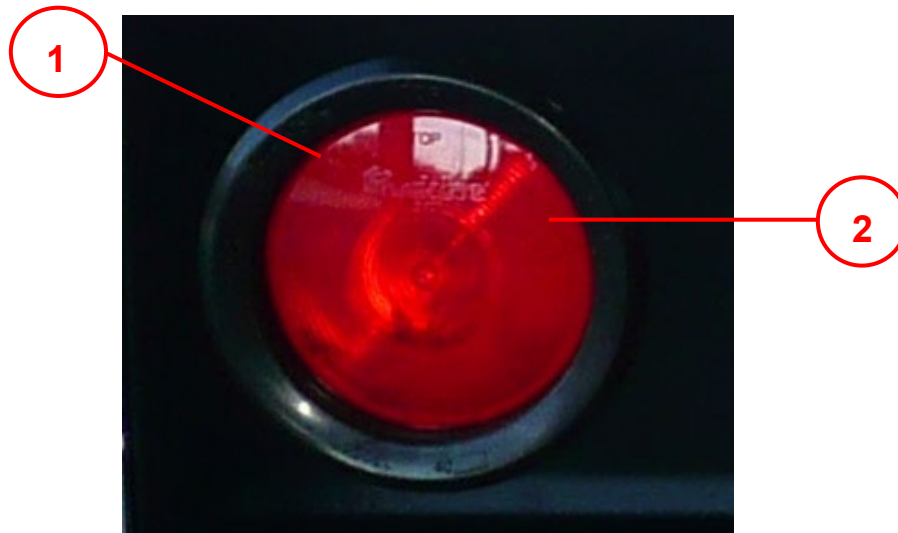
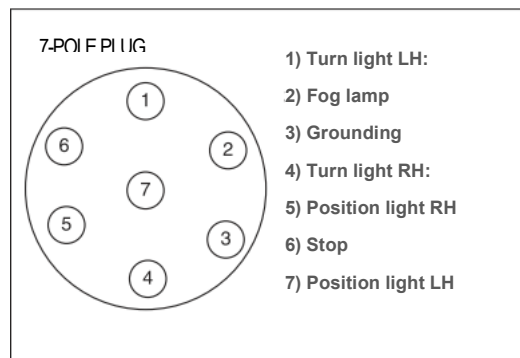

Figure 8.4-1 Rear light



WARNING: To replace the lamps, refer to the Maintenance chapter.

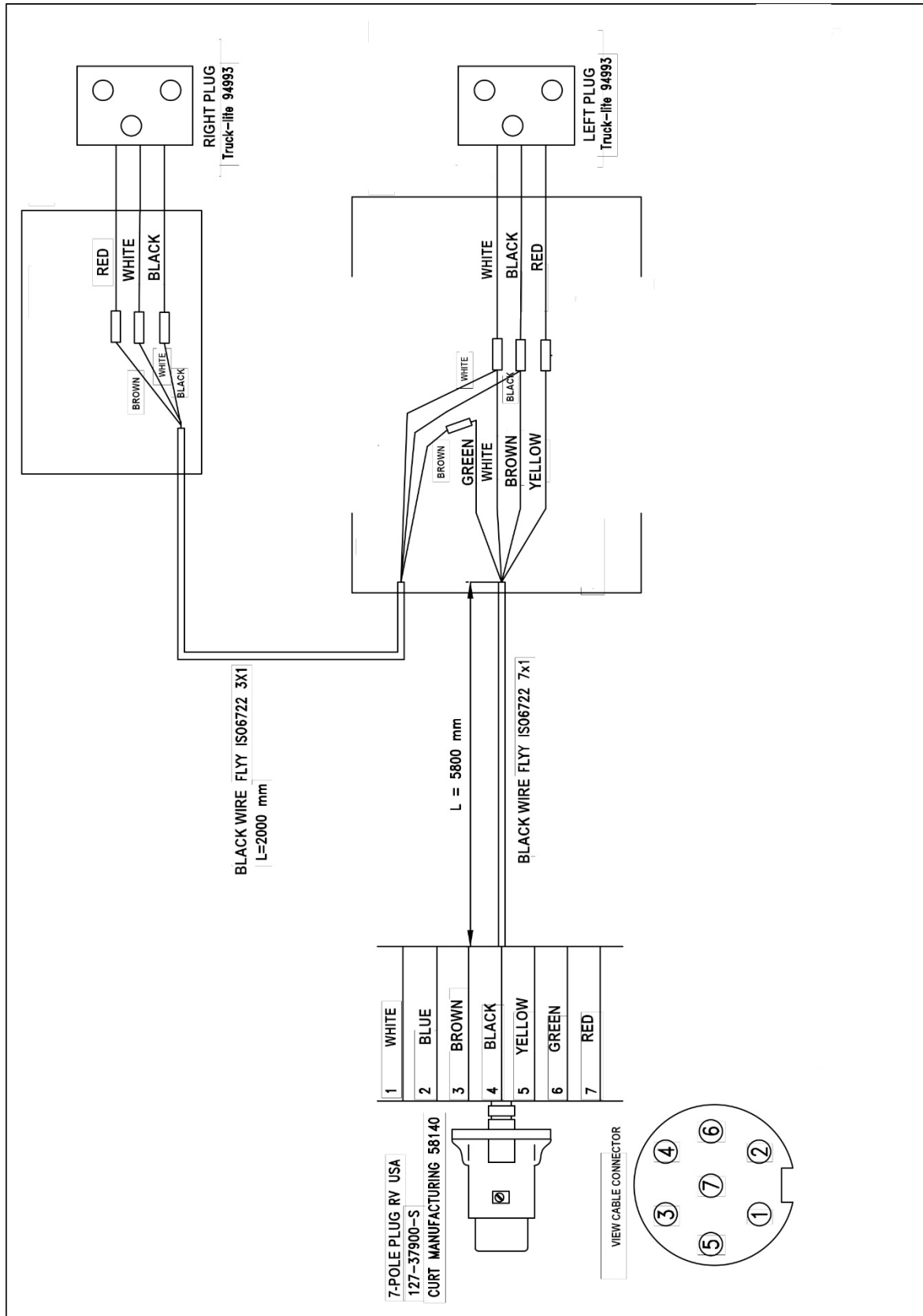
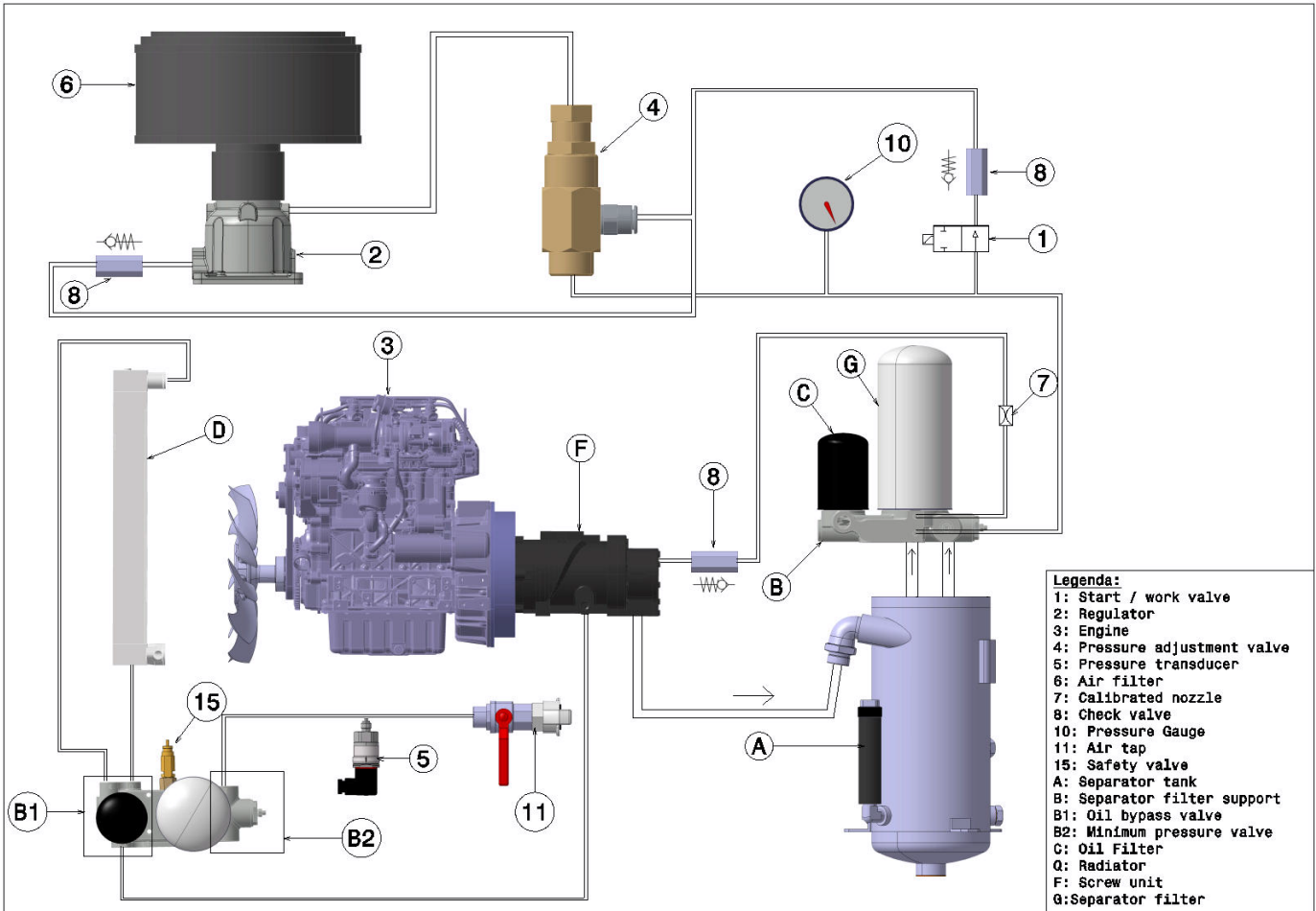

Figure 8.4-3 Light wiring harness



9 HYDRAULIC AND PNEUMATIC SYSTEMS



CAD-MADE DRAWING ANY MANUAL CHANGE IS FORBIDDEN
 It is strictly forbidden to reproduce this drawing without authorization

Figure 9.1-1 D185T4F (STANDARD) Hydraulic and pneumatic systems

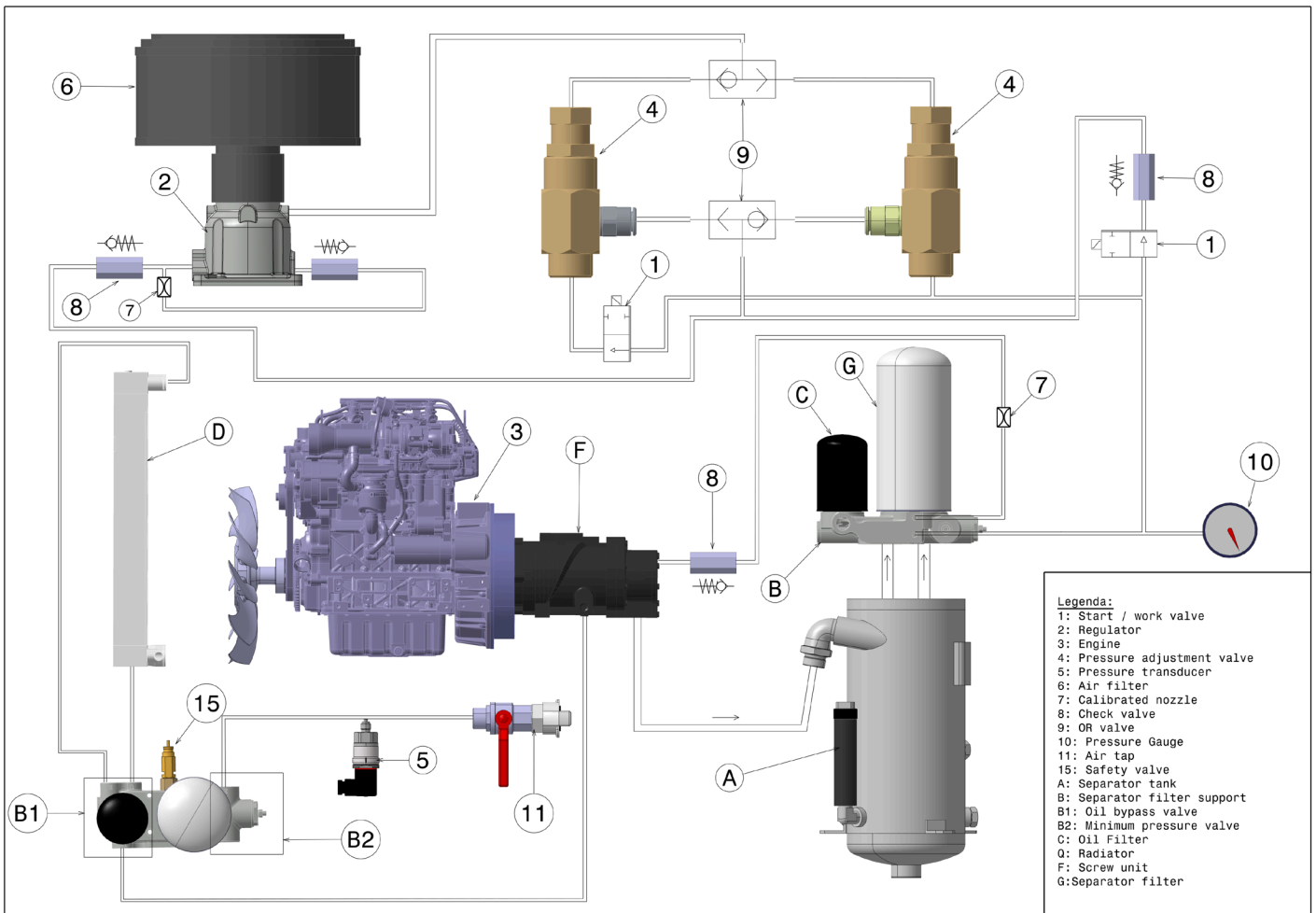

Figure 9.1-1 D185T4F (DUAL PRESSURE) Hydraulic and pneumatic systems

9.1 Hydraulic lubrication system

The hydraulic lubrication system (Figure 8.4-1) of the compressor consists of:

- Separator tank (A);
- Separator filter (G);
- Minimum pressure valve (B2)
- Oil filter (C);
- Oil cooling radiator (D);

As you may notice, the lower portion of the separator tank (A) is used as oil tank while the minimum pressure valve located in the upper part (B) operates as a support of the separator filter (G).

When starting up the machinery, the oil under pressure located in the tank starts flowing through the duct into the oil filter (C), and from there to the cooling radiator (D).

The cooled filtered oil then reaches the compressor (F) and - by means of appropriate inner piping - is distributed to the different organs (rotors, bearings, etc.), which are thus lubricated and cooled.

From the compressor (F), the oil -mixed to the compressed air in input from the check valve (8), is sent to the



	USER'S AND MAINTENANCE MANUAL	Date:	09/04/2024
		Code	MAN D185T4F ENG
Motor compressor : D185T4F		Revision	04

tank (A), where - through a forced centrifugal circuit - the compressed air is submitted to a first separation from the oil.

The resulting compressed air leaves the separator tank through the separator filter (G), which will provide to a second and last separation of the air from the remaining oil.

Even though the separating filter (G) separates the air from the oil, it is worth pointing out that a limited quantity of the latter manages to penetrate inside the filter and deposits on the lower portion of the filter itself.

The oil is sucked into the piping where a calibrated orifice (7) and a check-valve (8) will route it to the compressor (F).

The check valve (8) shall prevent the oil from returning into the separator filter (G) when the machinery is stopped.

Attention! The oil filter (C) is provided with a "by-pass" valve which allows the oil to circulate also in case it is clogged. In such case, the oil shall circulate regularly without being filtered.



WARNING: The filter needs therefore to be replaced at regular intervals, as specified in the maintenance program.

9.2 Pneumatic system

The pneumatic system (Figure 8.4-1) includes:

- start/work valve (1).
- Air filter(6);
- suction regulator (2);
- compressor (F);
- separator tank (A);
- separator filter (G);
- the min. pressure and check valves integrated (B2)
- tap (11);
- Max. pressure record valve (4);

The sucked air, after passing through the air filter (6), reaches the suction regulator (2) and, therefore, at the compressor (F) which, after compressing it, conveys it, together with the injected oil, into the oil separator tank (A). Here the separation of oil from air occurs. This process, as indicated above, is carried out in the first instance by centrifugal force, and secondly, by using the oil separator filter (G).

Once the air is purified from the oil, is conveyed to the minimum pressure valve (B2), which opens only when the pressure in the tank has reached the established value.

It is in any case a good practice not to use tools that - with their excessive consumption - may cause the lowering of the pressure in the tank under 5-5.1 bar – 72,5 PSI. Lengthened working conditions below 5 bar may create insufficient separation of oil from air, with a subsequent anomalous consumption of lubricant.

The minimum pressure valve (B2) also acts as a one-way valve, preventing the return to the air group compressed from pipes or tools connected to the machine.



WARNING: pressure vessel



	USER'S AND MAINTENANCE MANUAL	Date:	09/04/2024
		Code	MAN D185T4F ENG
Motor compressor : D185T4F		Revision	04

9.2.1 AUTOMATIC ADJUSTMENT OF THE ENGINE RPM

The system controls the Diesel engine rpm as a function of the compressed air retrieved and includes:

- Max. Pressure valve (4);
 - Suction regulator (2);
 - Pressure transducer (5)
- With the engine running and the tap (11) fully open, the engine rpm are at the max. value and the suction adjuster is fully open.
 - Partially close the tap (11) to simulate a reduction in the air consumption with subsequent increase of the pressure in the tank (A).
 - When the tap (11) is progressively closed, the pressure reaches the established adjustment value and the max. pressure valve (4) ones letting the compressed air flow out and act - at the same time - on the pressure transducer (5) and under the suction regulator (2).
 - Under the action of such pressure the pressure transducer (5) proportionally decelerates the engine.
 - At the same time, the suction regulator (2) proportionally closes as well, thus reducing the passage of the air which is being sucked. Consequently, with the tap (11) closed and - subsequently - without any air retrieval, the engine shall stabilize at the minimum rpm it was adjusted for, while the suction regulator (2) of the adjuster shall move to an almost total closing position.
 - At this stage of the cycle, the sucked air is minimum and is used to compensate for any leakages and internal leakages of the circuit.
 - The pressure gauge on the control panel shall display the value of the max. final pressure.
 - When air is resumed to be retrieved, the max. Pressure valve (4) shall start closing again and shall be totally closed once the pressure valve lowers by approx. 1 bar versus the value of the max. final pressure.
 - At this stage, the compressor delivers the max. rate at the service pressure, since the internal pressure in the pressure transducer (5) accelerate the engine up to the max. Speed, and the suction adjustment valves is the full opening position.
 - If tools of greater consumption that the rated capacity of the compressor are used, the pressure gauge shall display a lowering of the pressure which - in any case - must never be lower than 5 bar.
 - Avoid sudden openings of the taps: they generate strong stress to the separator filter, with subsequent severe damage to the filter itself.



	USER'S AND MAINTENANCE MANUAL	Date:	09/04/2024
		Code	MAN D185T4F ENG
Motor compressor : D185T4F		Revision	04

10 PROVISIONS FOR THE APPROPRIATE UTILIZATION OF THE MOTOR COMPRESSOR

Consult this user's and maintenance manual before starting-up the machinery.

10.1 Before starting-up

Before starting-up the machinery, strictly follow the instructions here in under:

1. Level the planarity of the machine by acting on the support foot or on the wheel: no incline greater than 15° is allowed;
2. make sure that the electric wires are connected to the battery terminals; if the connection is to be performed, use the greater care so that the cable coming from the starter motor is connected to the positive pole (+) of the battery and the earthing one is connected to the negative pole (-) of the battery.
3. Check the fuel level in the tank*.
4. Check the level of the engine oil: as related to the types of lubricant and relevant quantities, comply with the prescriptions contained in the engine manufacturer's users and maintenance manual enclosed to the machinery documentation.
5. Check the oil level in the compressor: this operation must be performed not before than five minutes have passed from the time the machinery was stopped, and this to allow the lubricant in circulation to flow completely into the separator tank.
 - a) Before unscrewing the filler plug where the level gauge is attached, make sure that there is no longer pressure in the system. (The pressure gauge shall indicate 0 bar).
 - b) Take off the plug and clean the level gauge.
 - c) Thoroughly screw back the filler plug and then take it off again to verify that the lubricant level is included between the two marks (min. and max. level) engraved on the gauge.
 - d) Top up if required: the level must never exceed the max. mark.
 - e) Exclusively utilize the types of oil recommended in this user's and maintenance manual.



Figure 10.1-1 Checking the oil level in the compressor



DIESEL

* Only use Diesel fuel for topping up.



	USER'S AND MAINTENANCE MANUAL	Date:	09/04/2024
		Code	MAN D185T4F ENG
Motor compressor : D185T4F		Revision	04



Figure 10.1-2 Fuel tank for Diesel engine

- 6 If the motor compressor is equipped with a liquid-cooling diesel engine, check the level of the cooling liquid contained in the radiator (Figure 10.1-3).



Figure 10.1-3 Checking the radiator cooling liquid

Recommended cooling liquid: ROLOIL ROL-ICE BLU



WARNING: *the radiator plug (Figure 10.1-3) must never be removed when the engine is hot: this would cause a sudden outflow of liquid which might cause severe scalding. Topping up - if required - must be made by means of a blend of water and anti-freeze liquid, in the percentage indicated on the container of the latter.*



	USER'S AND MAINTENANCE MANUAL	Date:	09/04/2024
		Code	MAN D185T4F ENG
Motor compressor : D185T4F		Revision	04

10.2 Start-up

Operations to be carried out for correct starting of the motor compressor:

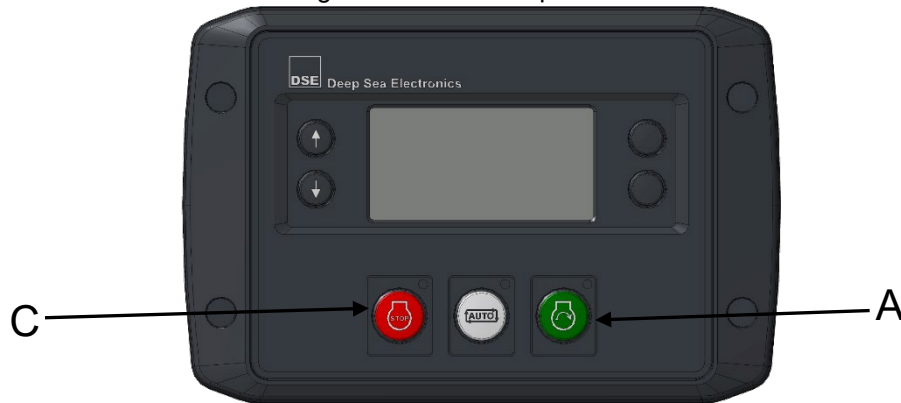



Figure 10.2-1 Electronic control board

- 1) Completely close the air supply cocks
 - 2) Place the ON / OFF switch (detail 3 Figure 8.1 1) in the "ON" position, the panel is powered
 - 3) Press the green button of the start button (A), the engine starts.
 - 4) Once the engine is started, it will run at minimum speed for about 40 seconds; the pressure gauge will indicate a pressure level between 2-3 bar.
- If one or more of the lights on the control device are still on after 5-6 seconds, stop the machine immediately to find the cause.
- After 40 seconds the motorized compressor will automatically enter work mode: the motor will accelerate, the suction valve will open and the pressure gauge will reach the maximum calibration values.
- 5) Then connect the compressed air delivery pipes to the relative tools.
 - 6) Gradually open the taps (B).
 - 5) Then connect the compressed air delivery pipes to the relative tools.



WARNING: *It is forbidden to open the machinery with the engine hood open.*



	USER'S AND MAINTENANCE MANUAL	Date:	09/04/2024
		Code	MAN D185T4F ENG
Motor compressor : D185T4F		Revision	04

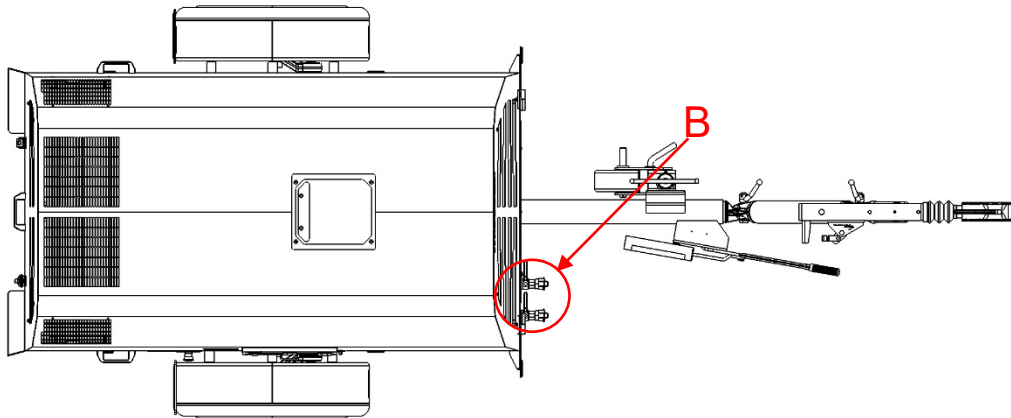

Figure 10.2-1 Location of the taps (top view)



WARNING: Do not breathe the compressed air produced by this unit in output from the taps

10.3 During the work cycle



The machine must always operate with the hood down and closed.

During the work cycle it is necessary to verify that the intake openings are free of foreign bodies such as pieces of paper, plastic, etc ... as these materials can create obstructions to the ventilation system.



Figure 10.3-1 Exhaust pipe



WARNING: in the vicinity of the exhaust pipe are very hot exhaust gases and harmful. DO NOT stop in the vicinity of the exhaust pipe

10.4 Stop

- 1) Completely close the taps (Letter B - Figure 10.2-1).
- 2) Press the red stop button (C) the compressor will act to depressurize the machine until the pressure of the gauge reaches a value of 3.5 bar before stopping.
- 3) Place the ON / OFF switch (detail 3 Figure 8.1 1) in the OFF position;



ELGI TM	USER'S AND MAINTENANCE MANUAL	Date:	09/04/2024
		Code	MAN D185T4F ENG
Motor compressor : D185T4F		Revision	04

10.5 After stopping the machine

- 1) If the machine has operated in dusty environments, it will be necessary to clean or replace the air filter and check the status of cleaning the cooling radiator; where this is clogged, it will proceed as indicated in paragraph maintenance.
- 2) Check that during the working phase there are no losses of fuel or lubricating oil inside the machine
- 3) Where possible place the machine away from the elements.

11 MONITORING AND TESTING OF THE MACHINE

11.1 Monitoring and testing of engine speed



ALL TESTING AND CALIBRATION SYSTEMS MINIMUM AND MAXIMUM, MUST BE DONE BY A PROFESSIONAL, INFORMED, FORMAT AND TRAINED, EQUIPPED WITH A SPECIAL EQUIPMENT TACHYMERIC A STRIKER REFLECTIVE AND EQUIPPED WITH HEADPHONES NOISE.



For all calibrations and adjustments we highlight the following residual risks



Presence of organs of motion. Pay attention to mechanical risks.



The presence of hot surfaces at high temperatures. Pay attention to the risk burn.



11.1.1 CONTROL SYSTEM OF MAXIMUM ENGINE SPEED



The calibration of the maximum speed is set by the manufacturer. It should not be changed for any reason. Any tampering or variation of the maximum speed of rotation of the motor will cause an immediate voiding of the warranty.

11.2 Monitoring and control of the air pressure of the compressor

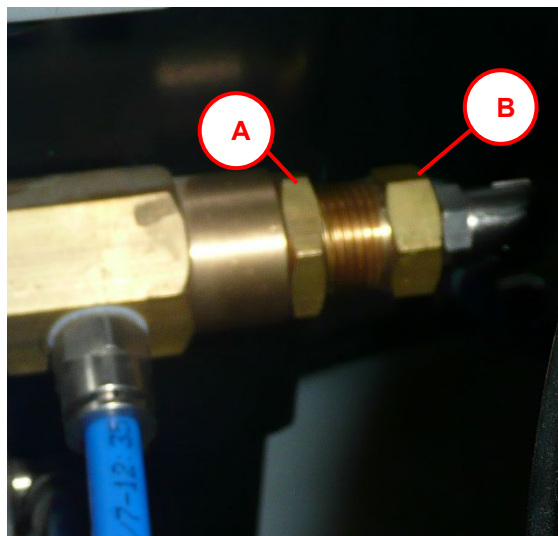



Figure 11.2-1 Adjusting maximum pressure pneumatic circuit

The maximum pneumatic pressure is calibrated during the testing phase of the machine.



	USER'S AND MAINTENANCE MANUAL	Date:	09/04/2024
		Code	MAN D185T4F ENG
Motor compressor : D185T4F		Revision	04

If the value of the maximum pressure pneumatic, indicated by the pressure gauge on the control panel, diverged over a $\pm 5\%$ from the value specified in Paragraph 2 of this manual, proceed as follows:

1. Start the machine as described in section 10.2 "Start",
2. Wait for the compressor reaches the maximum pressure and the engine stating the values of idle speed;
3. Close all faucets (Letter A in Figure 10.2 1);
4. Open the bonnet with the compressor in motion;
5. Unscrew with wrench 22 mm in, the nut (Letter A in Figure 11.2 1); Air filter area:
6. If you want to increase the maximum pressure must tighten with 19 mm wrench, nut (Letter B in Figure 11.2 1);
7. If you want to reduce the regime min unscrew, with a 19 mm wrench, nut (Letter B in Figure 11.2 1);
8. Once the adjustment screw, with a 22 mm wrench, nut (Letter A in Figure 11.2 1);
9. Slightly open for 3/4 seconds, the faucet supply air to the engine to accelerate, and then close it. Repeat this 2-3 times to allow the settling of the valve.
10. Reading on the pressure gauge located in the control panel, the value of the maximum pressure reached;
11. Compare the measured value with that reported in Paragraph 2, repeat the steps up to the alignment of the two values;
12. Close the bonnet.



WARNING: Notice: if the gauge had a discontinuous, jerky, you will have to replace it. So, before making any calibration valve high or low pressure, make sure that the gauge is efficient and reliable.



	USER'S AND MAINTENANCE MANUAL	Date:	09/04/2024
		Code	MAN D185T4F ENG
Motor compressor : D185T4F		Revision	04

11.3 Monitoring and control of air pressure minimum compressor

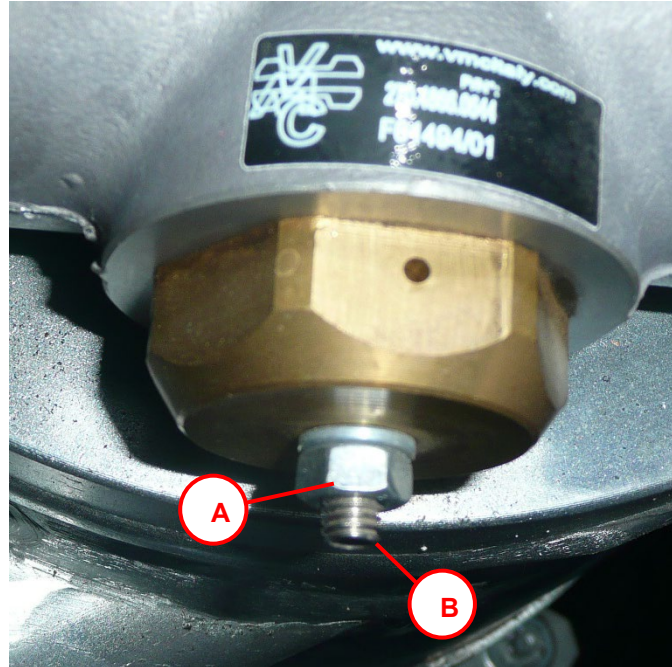

Figure 11.3-1 Adjusting minimum pressure pneumatic circuit

The minimum pneumatic pressure is calibrated during the testing phase of the machine.

If the minimum pressure pneumatic, indicated by the pressure gauge on the control panel, diverged over a $\pm 5\%$ from the value specified in Paragraph 2 of this manual, proceed as follows:

1. Start the machine as described in section 10.2 Start.
2. Wait for the compressor reaches the maximum pressure and the engine stating the values of idle speed;
3. Gradually open the air valve (Letter A in Figure 10.2-1);
4. Open the bonnet with the compressor in motion;
5. Unscrew, with 10 mm wrench, nut (Letter A Figure 11.3 1) located in the vicinity of the exhaust cleaner. Please Translate These points.
6. If you want to increase the maximum pressure must tighten the Allen screw (Figure 11.3 Letter B 1) with Allen key 3 mm;
7. If you want to reduce the regime min loosen the Allen screw (Figure 11.3 Letter B 1) with Allen key 3 mm;
8. Once the adjustment screw, with a 10 mm wrench, nut (Letter A Figure 11.3 1) and turn off the taps;
9. Reopen slowly the air tap (Letter A Figure 10.2 1) and close it again repeating the process a few times to allow the settling of the valve;
10. Close the bonnet.



WARNING: *Pressure vessel*



	USER'S AND MAINTENANCE MANUAL	Date:	09/04/2024
		Code	MAN D185T4F ENG
Motor compressor : D185T4F		Revision	04

12 SAFETY DEVICE

12.1 Verification of the safety valve

The safety valve is located on the oil separator tank and starts working to download any accidental overpressure.

The calibration of this valve is performed and verified in the testing of the factory and cannot be varied for any reason or tampered with.

Its efficiency should be checked quarterly by doing the following:

- 1) Start the machine the machine as described in section 10.2 "Start"
- 2) With the valves closed and with the engine at idle speed, using forceps, pick up the pin, as shown in Figure and release it as soon as you have the perception that the valve exhausts air.

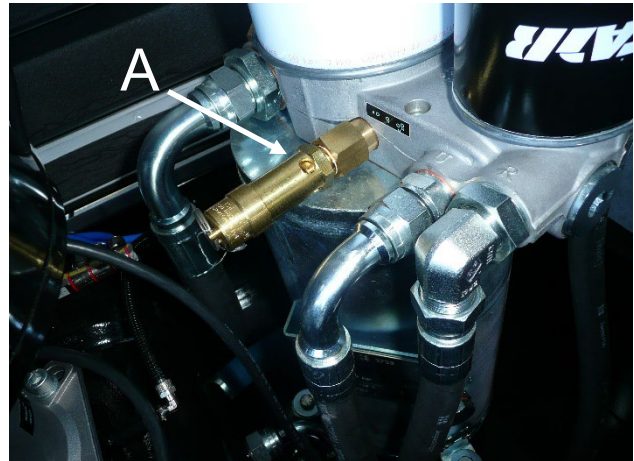
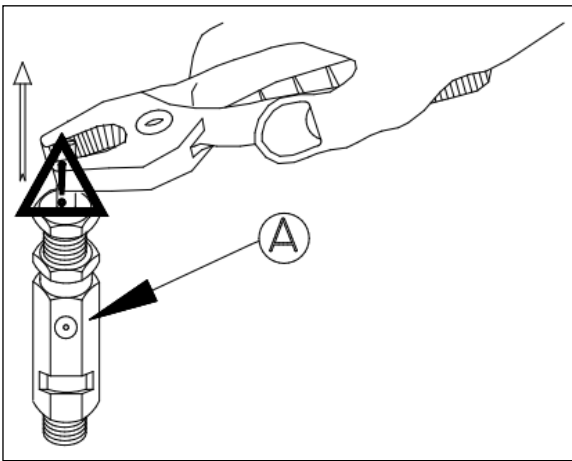

Figure 12.2-1 Control of the safety valve



WARNING: The air escaping from the valve during this operation control is also composed of small particles of oil.



WARNING: Pay attention to the danger of projection of liquids.



If, following the traction using a clamp, the pin is not raised, thus preventing the valve to vent, will require an immediate replacement of the same.



In case of replacement, it is recommended to contact the ELGI service, quoting the serial number of the machine.

The use of a safety valve is not original and does not comply, ELGI exempt from any liability.



	USER'S AND MAINTENANCE MANUAL	Date:	09/04/2024
		Code	MAN D185T4F ENG
Motor compressor : D185T4F		Revision	04

13 MAINTENANCE



The machine must be subjected to regular periodic maintenance in order to keep unchanged the technical characteristics, and safety originate.

Maintenance work must be performed by qualified personnel of patterns and designs, the machine stopped and power switched off to the electrical panel. Therefore, all maintenance must be carried out only after turning off the machine.



The staff of the service maintenance has to check that they have withdrawn their tools at the end of surgery and before starting the machine again, to avoid damage to the moving parts.

13.1 Routine maintenance

Means with **routine maintenance**, all the maintenance actions that its sole objective was to bring back a system (or one of its components) from a state of failure, the state is working properly before the onset of the problem, without changing or improving the functions performed by the system, nor to increase the value, or improve performance.

Maintenance includes all those periodic operations including:

In the following chapter are listed in order of frequency, all transactions concerning the compressor part, while as regards the part of the engine, it will be necessary to refer to OPERATING AND MAINTENANCE, which is prepared by the manufacturer of the engine and that is as supplied with the machine



	USER'S AND MAINTENANCE MANUAL	Date:	09/04/2024
		Code	MAN D185T4F ENG
Motor compressor : D185T4F		Revision	04

13.2 Maintenance program

In this program are listed all the interventions and their frequency to be executed on the various components of the machine. Such interventions are essential for the proper functioning of the machine and its mechanical durability over time.

<i>RECOMMENDED OPERATIONS</i>	<i>FREQUENCY</i>
Checking the oil level compressor	Daily
Check engine oil level (refer to the manufacturer's manual)	Daily
Checking Coolant Level	Daily
Check fuel level and top up (if necessary)	Daily
Check oil or fuel leakage	Daily
Check operation indicator lights	Daily
Check the readability of measuring instruments	Daily
General cleaning operations	Daily
Control of the absence of obstructions to the ventilation system	Daily
Control and clean up the air filter	Every 100 hours
Control and thorough cleaning air filter in dusty	Daily
Check operation lights and license plate lights (only for the approved version of the road)	Daily
Control of the air filter Compressor	weekly
Control of the engine air filter	(Ref. Manual of the engine manufacturer).
Checking the battery electrolyte level	Monthly
Checking tire pressure	Monthly
Checking belt tension Quarterly	Three months
Speed control the minimum and maximum engine	Three months
Control of the efficiency of the safety valve	Three months





USER'S AND MAINTENANCE MANUAL

Date: 09/04/2024

Code MAN D185T4F ENG

Motor compressor : D185T4F

Revision 04

RECOMMENDED OPERATIONS	FREQUENCY
Cleaning the oil cooler	Three months
Control nozzle oil recovery	Three months
Drainage of the fuel tank	Three months
Replacing diesel pre-filter	Every 500 hours
Control of the efficiency of the braking system	Three months
Control and wheel lock	Three months
Change engine oil	(Ref. Manual of the engine manufacturer).
Oil Filter Replacement compressor	After the first 50 hours
Replacing compressor oil	After the first 50 hours
Control of tightening screws and bolts of the compressor and engine silent-blocks	Every 50 hours
Control of tightening screws and bolts	Every 100 hours
Check tightness of all pipe connections	Every 100 hours
Replace Air Filter Compressor	After 500 hours
Replace oil filter compressor	After 500 hours
Replacing compressor oil	After 1500 hours
Replacing oil separator element	After 2000 hours
Check-up by the service "authorized ELGI".	Every 3000 hours
Control readability nameplate EC Annual	Annual
Control valves from service "authorized ELGI".	Biennial









The ELGI disclaims any responsibility for the failure to comply with maintenance requirements in the table above.



13.3 Values of tightening screws and bolts

For the correct tightening of screws and bolts on the machine please observe the tightening values corresponding to the class of coupling illustrated in the table below.

We recommend the use of torque wrenches for tightening the screws and bolts on the machine.

Torques not binding N.m (Newton meters)							Couples test sockets for hexagonal screws																												
<p>These pairs are reference values for normal metric threads according to DIN ISO 261 and measures supporting heads according to DIN EN ISO 4762, DIN ISO EM 4032, DIN EN ISO 4014 and DIN 931-2, 6912, 7984 and 7990. With these values obtains an exploitation of 90% of the yield strength of the screws, on the basis of a coefficient of friction equal to 0.14 (screw new, untreated, not lubricated). Important: In extreme cases, e.g. screws lubricated with MOS2 and coupling elements cadmium-plated on both sides, the value of torque should be reduced by about 20%.</p>							No. 2, 2A, 2B		No. 4		No. 6, No. 1B, 7, 400		No. 25		No. 26 R No. 626		No. 35 A No. 35 B No. 3112		No. 894 No. 895																
							No. 1B, 308, 7																												
	Tightening values for classes of coupling according to DIN 267							      																											
	4.6	5.6	6.9	8.8	10.9	12.9		4	4,5*	5	5,5	6*	7	7	8	8	9*	10	11	12	13	14*	15	16	17	18	19*	20*	21	22*	23*	24	25*	26*	
M 2	0,123	0,162	0,314	0,373	0,520	0,628	4							1,90																					
M 2,2	0,196	0,265	0,510	0,598	0,843	1,010	4,5*							2,64																					
M 2,5	0,284	0,373	0,726	0,863	1,206	1,451	5							3,55																					
M 3	0,441	0,588	1,128	1,344	1,883	2,256	5,5							4,64			14,4																	2,32	
M 3,5	0,677	0,902	1,736	2,060	2,893	3,481	6*	17,6	7,4	5,92				17,6			17,6																	2,96	
M 4	1,000	1,344	2,599	3,040	4,315	5,148	7	25,2	11,4	9,12				25,2																				4,56	
M 5	1,916	2,648	5,099	6,031	8,483	10,200	8 9*	34,5 45,4	16,6 23	13,3 18,4				34,5 45,4	34,5 45,4	6,65 9,20																			
M 6	3,432	4,511	8,728	10,300	14,710	17,652	10	58,1	31	24,8	58,1	58,1	58,1	58,1	58,1	12,4																			
M 7	5,590	7,453	14,220	17,162	24,517	28,439	11 12	72,7 89,1	40,4 51,5	32,3 41,2	72,7 89,1	72,7 89,1	72,7 89,1	72,7 89,1	72,7 89,1	16,1 20,6																			
M 8	8,238	10,787	21,575	25,497	35,304	42,168	13 14*	107 128	64,5 79,4	51,6 63,5	107 128	107 128	107 128	107 128	107 128	25,8 31,7																			
M 10	16,67	21,575	42,168	50,014	70,608	85,317	15 16 17	150 175 201	96,2 115 134	77,0 92,3 107	150 175 201	150 175 201	150 175 201	150 175 201	150 175 201	38,5 46,1 53,5																			
M 12	28,44	38,246	73,550	87,279	122,60	147,10	18 19* 20*	230 261 294	160 186 215	128 149 172	230 261 294	230 261 294	230 261 294	230 261 294	230 261 294	64,0 74,5 86,0																			
M 14	45,11	60,801	116,70	138,30	194,20	235,40	21 22* 23*	330 368 408	247 281 319	198 225 255	330 368 408	330 368 408	330 368 408	330 368 408	330 368 408	99,0 112 127																			
M 16	69,63	93,163	178,5	210,80	299,10	357,90	24 25* 26*	451 496 544	359 402 449	287 322 359	451 496 544	451 496 544	451 496 544	451 496 544	451 496 544	143 161 179																			

13.4 Maintenance

13.4.1 CHECKING AND CLEANING AIR FILTERS AIR INTAKE

This check should be performed periodically every 100 hours of work;

If the machine operates in a very dusty environment, it will also be necessary on a daily basis.

- COMPRESSOR AIR FILTER

**B**

Figure 13.4-1A Aspiration air filter

1-The filter consists of two filtering cartridges (1st and 2nd stage): to check them loosen the nut (fig.13.4-1A part 1) and extract the cartridge of the 1st stage part 3.

2- Should any traces of dust be noticed on the cartridge of the 2nd stage also part 5, extract this one also, unscrewing the nut part 4.

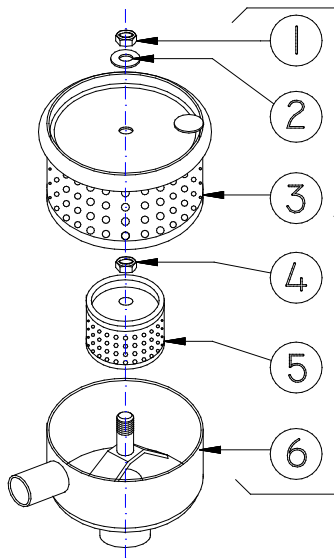

The filter cartridge must never be washed with water or other substances and never cleaned with compressed air but replaced;



It must, however, be replaced every 500 hours of work.

	USER'S AND MAINTENANCE MANUAL	Date:	09/04/2024
		Code	MAN D185T4F ENG
Motor compressor : D185T4F		Revision	04

13.4.2 CONTROL THE ELECTRICAL BATTERY



Figure 13.4-2 Battery compartment



Extended not-use of the machine - battery charge status



- To avoid complete discharge of the battery, if the machine is not to be used for > 3 months, disconnect the negative terminal of the electrical system.
- Periodically check the battery charge and recharge it every 3 months.

Cleaning the terminals

The battery terminals (poles) must be cleaned and greased periodically. The accumulation of dirt can hinder the passage of electric current.

For cleaning it is necessary to switch off the machine, disconnect the terminals starting from the negative terminal and clean the terminals.

Checking the clamps

Generally the negative and positive pole of the battery are greased (eg. Pulp vaseline or similar product) to avoid the oxidation of metals. The paste on the clamps must be periodically replaced.

In the same way, check that the terminals are firmly connected to the battery poles and if necessary tighten them. In fact, it may happen that vibrations loosen the grip of the clamps. A mobile connection can cause malfunctions and even failures to the vehicle's electrical devices.

Checking the battery fluid (in the case of an unsealed battery)

The electrolyte must always reach the covering level of the element plates.

If the battery fluid is low, it may compromise its operation.

In these cases, if the level of covering is below the minimum level it is necessary to have it checked by a qualified electric maintenance technician and if necessary to provide the addition of cold water distilled water to restore the liquid level.

If, despite top-up, the battery continues to discharge frequently, it must be replaced.



CAUTION: Take special care when handling battery fluid. Potentially corrosive liquid.



	USER'S AND MAINTENANCE MANUAL	Date:	09/04/2024
		Code	MAN D185T4F ENG
Motor compressor : D185T4F		Revision	04

13.4.3 FUSO REPLACEMENT

Fuse replacement should be performed when one or both fuses were damaged or not intervene.

To replace the fuse proceed as follows:

- 1) Stop the machine;
- 2) Open the bonnet;
- 3) Open the fuse box;
- 4) Pull the fuse to be replaced with tweezers (to fuse 15 A), and unscrew the screws for the 40 A fuse:
- 5) Once removed the fuse concerned, observe the internal filament, this must be intact to function properly, if this is the case simply up item. If this filament is sectioned into two means this is to be replaced;
- 6) In the event of a damaged fuse replace it by choosing a fuse with identical characteristics. The characteristics of the fuses are described 8.3in this manual;
- 7) After inserting the new fuse in the housing close the fuse box;
- 8) Close the bonnet;
- 9) Now you can restart the machine.



13.4.5 CLEAN THE RADIATOR COOLER

The coolants of the compressor and the motor are cooled by a radiator which, consequently, must be kept clean so that the ventilation air can pass freely and easily through its fins honeycomb.

A radiator fins clogged with dust or any other bodies, because of the harmful and dangerous overheating to the mechanical screw compressor, greatly jeopardizing the operation and durability. We recommend that you check it periodically and, if necessary, clean it with compressed air or clean it with a jet of water under pressure.

13.4.6 PERCENTAGE DOSAGE OF COOLING LIQUID

To determine the proper amount of antifreeze to be paid within the tank of the radiator (Figure 13.4-3) must follow the following table:

T (°C / °F)	Total volume of the cooling plant	Water volume	Antifreeze volume	Antifreeze percentage*
(°C / °F)	(lt - gal)	(lt - gal)	(lt - gal)	%
- 10 / 14	14 – 3,70	10,5 – 2,80	3,50 – 0,90	25%
- 15 / 5	14 – 3,70	9,1 – 2,40	4,90 – 1,30	35%
- 20 / -4	14 – 3,70	7,7 – 2,00	6,3 – 1,70	45%

*Cooling liquid suggestions: ROLOIL ROL-ICE BLU



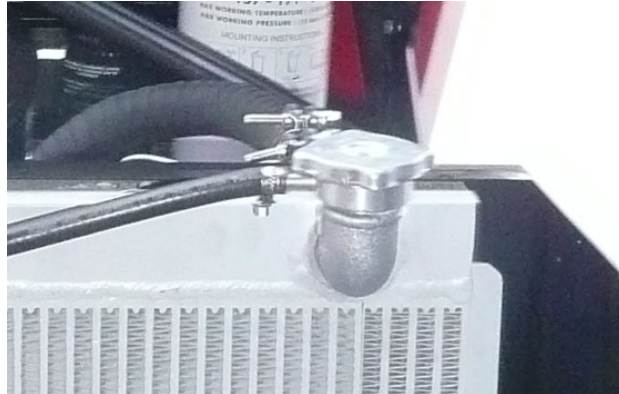

Figure 13.4-3 Checking the coolant radiator



WARNING: He radiator cap (Figure 10.1-3) must never be removed in a warm engine: in this condition would occur a sudden leakage, which could cause serious burns to the person. The possible filling must be done with a mixture of water and antifreeze liquid, in the percentage indicated on the container of the latter.

13.4.7 CHECKING AND CLEANING OIL RECOVERY ORIFICE

Control and clean the oil recovery is to be performed, should you find a leak of oil mist mixed with air compressed, operating as follows (Figure 13.4-4).

- 1) Unscrew the fitting located at the center of the tank (Letter Z in Figure 13.4-4);
- 2) Inside the ring (Letter Z in Figure 13.4-4) is a nozzle (Letter U in Figure 13.4-4): make sure that its calibrated hole is not blocked (blow with compressed air);
- 3) Replace the fitting.



WARNING: During normal operation of the compressor, in the pipe from the fitting transparent part (Z), you will notice a certain amount of oil flow from the said fitting (Z) towards the head of the compressor

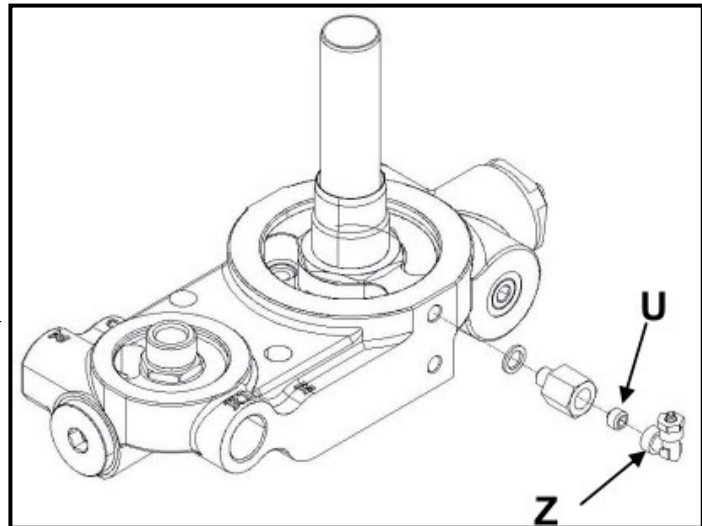

Figure 13.4-4 Oil recovery orifice

13.4.8 DRAINAGE OF THE FUEL TANK

The draining of the fuel tank has the aim to eliminate the water possibly settled on the bottom of the tank due to the formation of condensation or refilling fuel polluted.

Avoid fuel filling with cans because sometimes, these may contain traces of water which, being heavier than the gas oil, is deposited on the bottom and can build up to reach the level of the dip tube.



Periodically carry out the drains to prevent even small parts of water can be aspirated and injected into the engine.

It is also advisable to carry refuel at the end of the work shift to prevent the temperature range of the tank walls make possible the formation of condensation inside it.

In conjunction with the drainage of the tank, also proceed to the replacement of the fuel filter to eliminate from the fuel every trace of water.

	USER'S AND MAINTENANCE MANUAL	Date:	09/04/2024
		Code	MAN D185T4F ENG
Motor compressor : D185T4F		Revision	04



The draining of the tank must be performed at least 30 minutes after stopping the machine, to allow water to separate from the diesel fuel and to settle to the bottom of the tank.

The polluted fuel spilled from the purges should be collected and delivered to specialized centres and authorized the collection and disposal of hazardous waste.



Remember that the residual fuel should not be totally discarded in the environment.

13.4.9 REPLACING DIESEL FILTER AND PRE-FILTER



As for the controls of the engine and replacing diesel filter, timing belt, motor oil, and other specific controls refer to the owner's manual of the engine manufacturer attached to this documentation.

13.4.11 CONTROL OF LOCKING WHEEL BOLTS

Periodically check the tightness of the wheel bolts using a spanner, avoiding the use of air screwdrivers that may damage the bolt threads.



	USER'S AND MAINTENANCE MANUAL	Date:	09/04/2024
		Code	MAN D185T4F ENG
Motor compressor : D185T4F		Revision	04

13.4.12 OIL FILTER REPLACEMENT COMPRESSOR

For proper filter replacement compressor oil must do the following:

- 1) Stop the machine and open the hood of the engine compartment;
- 2) Use a chain wrench to unscrew the filter to be replaced (Figure 13.4-6);
- 3) Oil the seal of the new filter to be tightened and only by hand;
- 4) Start the machine and make sure that there are no oil leaks in the vicinity of the seal, in this case to stop the machine and recheck the status and the correct positioning of the seal in its housing.



Figure 13.4-6 Compressor oil filter



WARNING: The filter is impregnated exhausted mineral oil pollution and harmful to the environment, therefore it must be disposed of at specialized centres of collection and treatment of waste.



	USER'S AND MAINTENANCE MANUAL	Date:	09/04/2024
		Code	MAN D185T4F ENG
Motor compressor : D185T4F		Revision	04

13.4.13 REPLACEMENT OF COMPRESSOR OIL

The oil compressor must be performed taking into consideration the working conditions in which the machine operates (dusty, very high temperatures, etc.).

The oil change intervals must never exceed 1,500 hours of work.

In conjunction with the replacement of the oil must be changed, the corresponding filter (Paragraph 13.4.12).

RECOMMENDED OIL	QUANTITY	PART NUMBER
AIRLUBE PORTABLE LUBRICANT	2.5 Gallons	512-12-0000
	5 Gallons	512-12-0001
	55 Gallons	512-12-0002
	330 Gallons	512-12-0003



WARNING: It is strictly recommended to use ONLY OIL FOR SCREW COMPRESSORS. ELGI declines any responsibility if other oils will be used.



13.4.14 CHECKING THE OIL MIST SEPARATOR

Filter life oiler is expected around 2000 hours of work, but is closely related to a careful observance of all maintenance requirements given in this manual.

A quantity of oil or excessively low in the tank, the breach of the frequency of oil changes or the use of the machine with cooling radiator clogged may determine an anticipated and irreparable deterioration of the filters. Therefore, if, after the control and clean the recovery (operation described in the paragraph 13.4.8) and making sure the proper oil level in the tank, you are still traces of oil in the compressed air, is will have to replace the exhaust cleaner.

To ascertain the degree of clogging of the filter separator operate as follows:

- 1) Install a pressure gauge upstream of the separator and make sure that on the machine is efficient.
- 2) Start the machine.
- 3) Partially open the faucet flow until the pressure gauge on the control panel shows the value of the operating pressure.
- 4) Read the value of the pressure gauge located upstream of the oil separator filter and compare two values: if, between the two readings, is a difference of more than 1 bar replace the filter separator

The oil separator filter must never be washed with water.



WARNING: *Pressure vessel*



	USER'S AND MAINTENANCE MANUAL	Date:	09/04/2024
		Code	MAN D185T4F ENG
Motor compressor : D185T4F		Revision	04

13.4.15 REPLACEMENT OF THE OIL SEPARATOR FILTER

To replace the oil separator filter proceed as follows:

- 1) The operation must be performed with the machine stopped and in the absence of pressure in the oil separator tank.
- 2) We recommend applying a cloth in order to contain any oil leakage that may occur during the replacement of the oil filter.
- 3) Unscrew the oil separator filter: the filter is situated above the oil separator tank
- 4) Replace the new filter making sure to lubricate the gasket.
- 5) The filter must be tightened by hand only.



Figure 13.4-7 Oil separator filter



WARNING: *Pressure vessel*

13.4.16 ENGINE CONTROL AND MAINTENANCE



As for the controls of the engine and replacing diesel filter, timing belt, motor oil, and other specific controls refer to the owner's manual of the engine manufacturer attached to this documentation.

14 SPARE PARTS



In case of need to order a single component contact your authorized service center ELGI.



	USER'S AND MAINTENANCE MANUAL	Date:	09/04/2024
		Code	MAN D185T4F ENG
Motor compressor : D185T4F		Revision	04

15 FAULTS AND TROUBLESHOOTING

Abnormal	Cause	Solution
The engine will not start.	Battery discharged or defective.	Recharge and replace if necessary.
	Terminals of the battery cables oxidized or loose.	Cleaning of the same and their tightening.
	No fuel.	Top up the fuel in the diesel tank.
	Solenoid faulty fuel.	Seek customer service by the manufacturer of the engine.
	Air in the fuel pipe.	Locate the infiltration by careful verification of all pipes.
	Injection pump defective.	Call in Customer Service by the engine manufacturer.
	Temperature sensors defective.	They are located at: - Headed-cylinder engine; - Output air compressor; - Tank separator. One at a time, unplug its power cable from the probes to identify the defective sensor and replace it. The temperature light on the control panel should go off.
Opening the taps the motor does not accelerate.	Starter defective Injectors failures	Call in Customer Service by the engine manufacturer.
	Control valve of maximum pressure defective.	Remove the control valve max and accurately control the spring and the conical seat. If the defect cannot be repaired, the valve must be replaced.
The engine speeds up but no air come out	Minimum pressure control valve blocked.	Disassemble and check that the piston is free to move. Check that the spring is intact. If the defect cannot be repaired the valve must be replaced. Reassemble and adjust the minimum pressure following the instructions in Section 11.3.
The machine stops suddenly and can only be restarted after a few minutes of waiting.	A temperature sensor detects a temperature anomaly and consequently stops the machine.	Take off one at a time, locate the probe that determines the stop. If that proves to be placed on the engine, check the oil level of the motor, the voltage and the conditions of the alternator belt. For water-cooled engines, check the coolant level. If it turned out to be the probe placed on the compressor control the level of 'oil in the tank and



	USER'S AND MAINTENANCE MANUAL	Date:	09/04/2024
		Code	MAN D185T4F ENG
Motor compressor : D185T4F		Revision	04

Abnormal	Cause	Solution
		if necessary top up; Check the cooling fan and clean the radiator; replace the oil filter of the compressor. If that proves to be positioned on the oil separator tank, check the oil separator filter following the instructions to Par. 13.4-15, proceeding to its eventual replacement Par 13.4-16.
Abnormal	Cause	Solution
The engine does not reach the maximum speed of the speed indicated and the compressor does not do.	The spring piston accelerator is broken or to be put under tension.	Check the tension of the spring piston accelerator (Par. 11.1.2).
	Engine speed lower than expected.	Have the injection apparatus of the motor by qualified personnel. Replace the fuel filter. Run the draining of the fuel tank (Par. 13.4.9).
Oil leaking from the taps.	Minimum working pressure too low.	Adjust it according to the instructions of Par. 11.3.
	Too much oil in the tank.	To the correct level (Par.13.4).
	The machine works in non-horizontal position.	Ensure position the machine level
	Nozzle clogged oil recovery.	See Par. 13.4.8.
	Defective exhaust cleaner.	See Par. 13.4.15.

	USER'S AND MAINTENANCE MANUAL	Date:	09/04/2024
		Code	MAN D185T4F ENG
Motor compressor : D185T4F		Revision	04

16 DISPOSAL, ELIMINATION, DISPOSAL OF THE MACHINE

16.1 Instructions for dismantling

To dismantle the machine safely, proceed as follows:

- 1) Place the machine in a wide and make sure it is turned off.
 - 2) Empty the liquid waste in the tanks of motor oil, fuel, coolant, hydraulic oil and store them in special containers. For disposal of these types of waste follow the next paragraph.
 - 3) Loosen the screws of the body and remove covers
 - 4) Remove all the components of the machine one by one dividing them according to their material composition
- The various components of the machine have to be disposed in relation to the type of waste to which they belong.

The following describes the different types of waste that can be generated during the life of the machine:

- Waste motor oil
- Waste compressor oil
- Residues of coolant
- Residual fuel
- Liquid remaining battery power
- Rags or paper impregnated with a diluents or other substances used for the cleaning of the various organs of the machine

17 ELIMINATING THE MACHINE

The operations of destruction and disposal must be carried out in a safe condition by a qualified specialist and after carefully reading and incorporated the recommendations and instructions provided in this section of the manual of use and maintenance and consulting the safety data sheets relating to substances in the machine mentioned in the previous chapter..

Once you reach the end of the mechanical life of the compressor, this has to be taken out of service so that it cannot be used for other purposes.



18 WASTE MANAGEMENT



The withdrawal of special waste and / or hazardous should be entrusted with the written contract to authorized firms; and those who physically transport and handling must be in possession of the required authorizations. The hauliers authorized must be enrolled in the relevant register.

18.1 Special waste

They are considered a hazardous waste residue from industrial, agricultural, crafts, commercial and service, for quality or quantity, is declared similar to municipal waste. These include also: machinery, equipment and metal parts of engines deteriorated and obsolete.



18.2 Toxic and hazardous waste



Are considered hazardous toxic waste all waste containing or contaminated by the substances listed in Directives 75/442 / CEE, 76/403 / CEE and 768/319 / CEE or other regulations in the countries of use and installation of the machines.



18.3 Temporary storage



Are considered hazardous toxic waste all waste containing or contaminated by substances listed in Directives 75/442 / CEE, 76/403 / CEE and 768/319 / CEE or other regulations in the countries of use and installation of the machines.

Temporary storage of toxic and hazardous waste is allowed according to the expected disposal of waste by treatment and / or final disposal. In any case, observe the mandatory laws of the country of the user in the field of environmental protection.

18.4 Features of the containers

The fixed and mobile containers, designed to contain toxic and hazardous waste must possess adequate strength requirements in relation to the chemical-physical properties and to its hazardous characteristics of the waste contained. The containers in which products are stored or dangerous or harmful materials must, in order to disclose the nature of their content, carry signs and markings prescribed.



18.5 Registration requirements

In accordance with the EU Directive 75/439 / CEE on the disposal of waste oil, the records of loading / unloading must be kept by all companies that produce hazardous waste or hazardous toxic from industrial and artisanal (in each case the 'Users should refer to the regulations implementing that Directive in the country of installation and use of the machines).

PARTS LIST

MOTORCOMPRESSOR

D 185T4F



4610 Entrance Drive St A - Charlotte, NC 28273

PHONE: 704-523-4123

E-MAIL: Portableservice@elgi.com - Portablesales@elgi.com;

Copyright © 2014, ROTAIR S.P.A. - All rights reserved This manual is intellectual property of ROTAIR S.P.A. Its full or partial reproduction is forbidden under any form, on any support and by any means, without the written authorization by ROTAIR S.P.A.

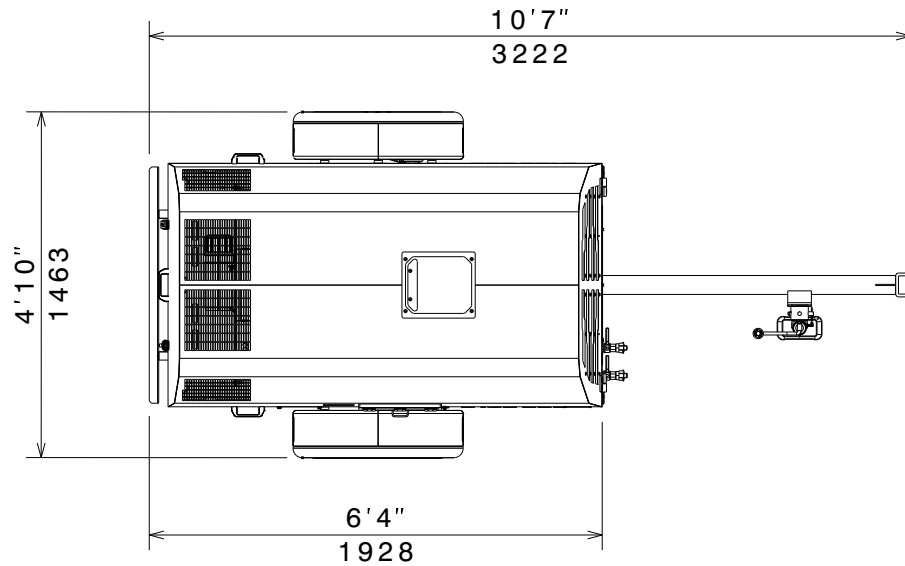
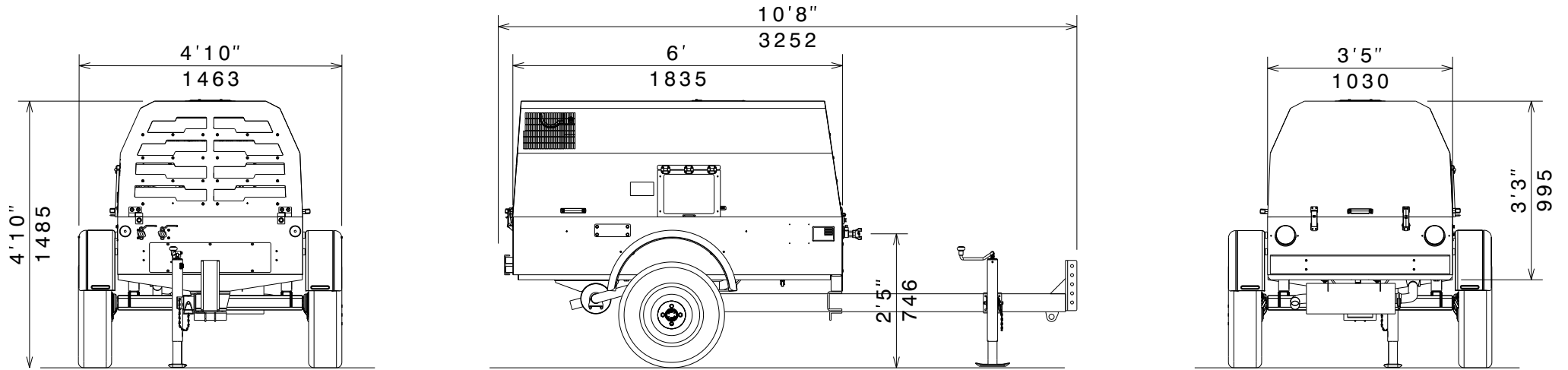

Feet/Inches
mm



This page has been intentionally left blank

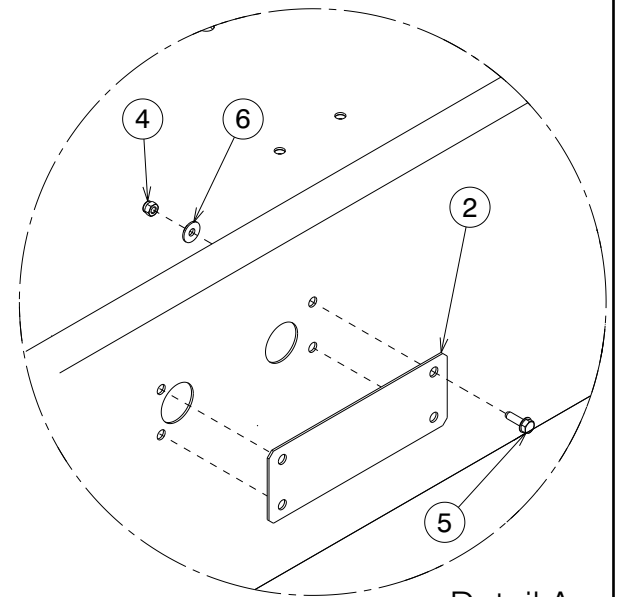
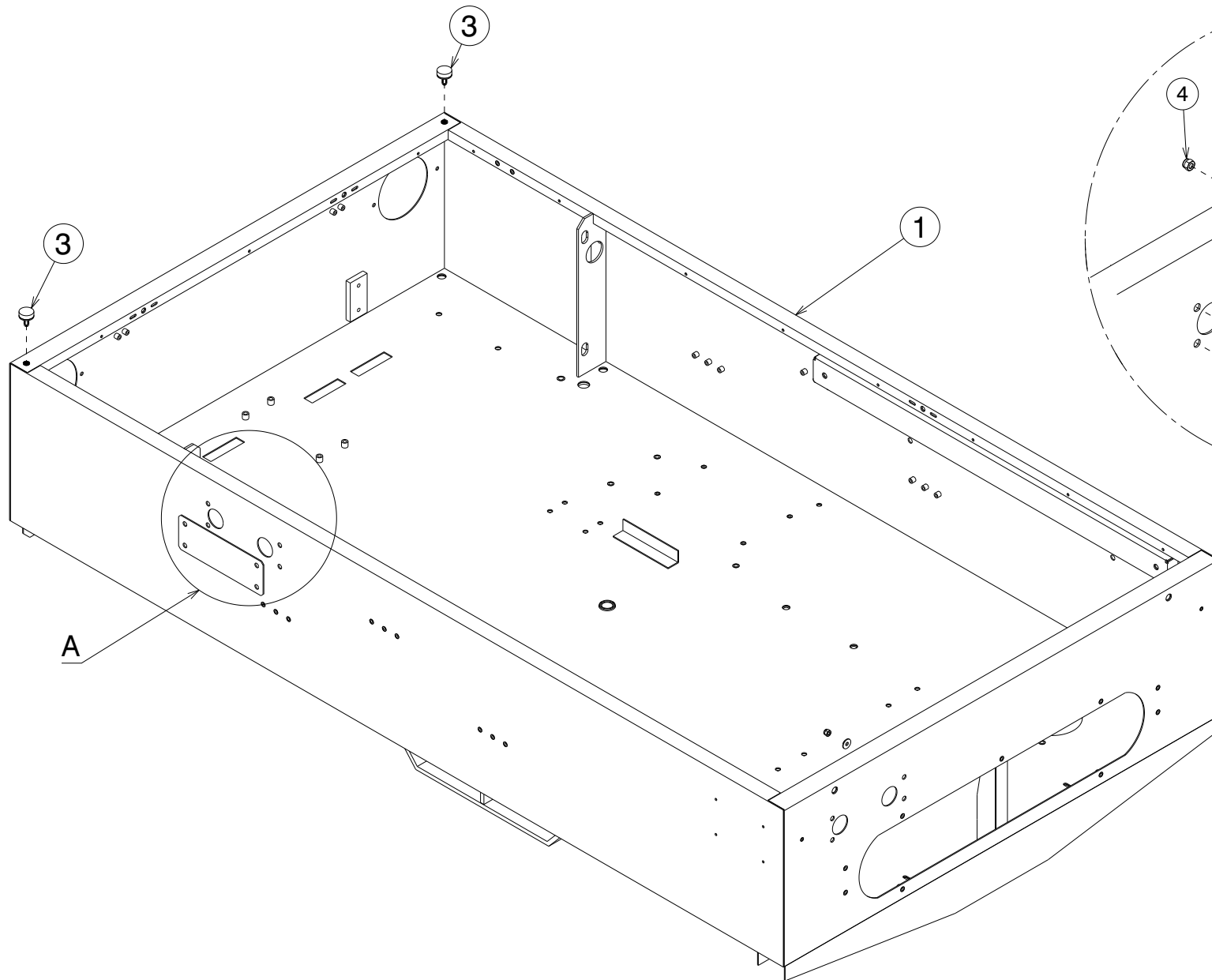

Detail A



PARTS LIST

Motocompressor – D185T4F

PARTS LEGENDA: Chassis

Tab. 01.1

REF	NAME	CODE	QUANTITY
1	Chassis	038-0525990-S	1
2	Closing panel	124-307899-S	1
3	Silent block	061-900-S	2
4	Hex nut M8 UNI 7473	137-040-S	4
5	Hex head screw . M8x20	132-10105-S	4
6	Washer d. 8x17x1,5	015-030-S	4

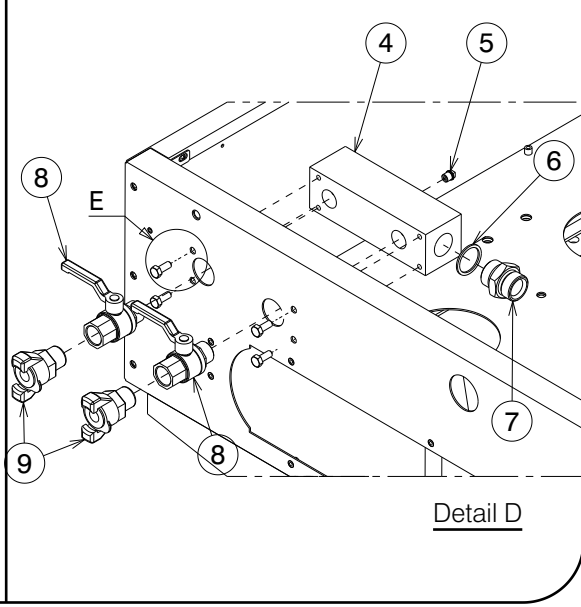
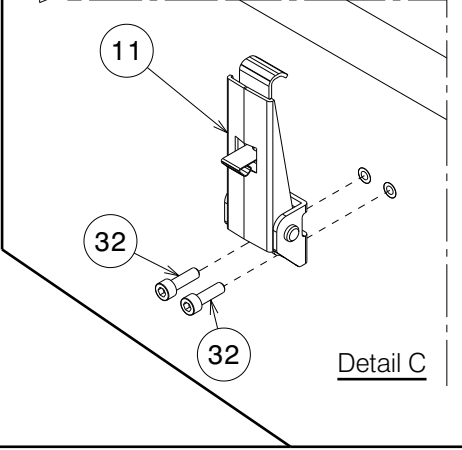
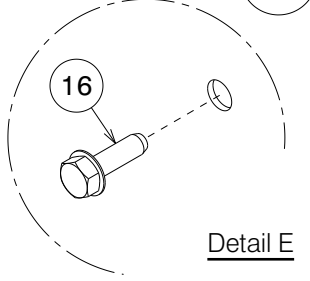
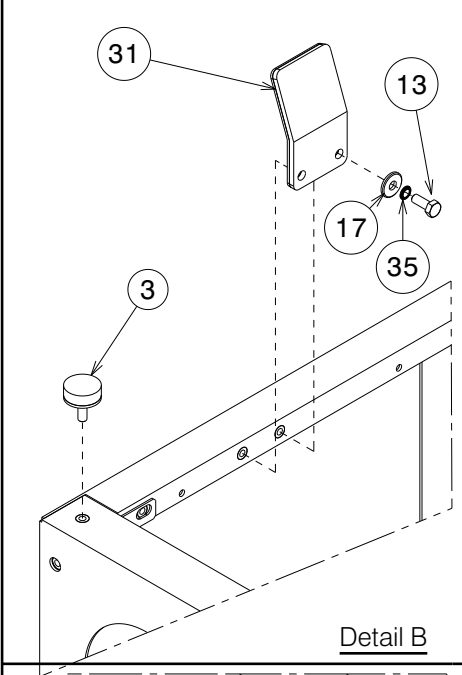
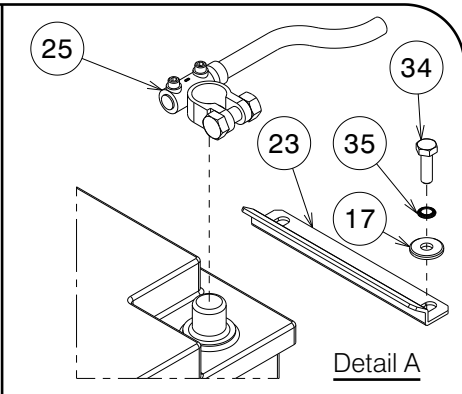
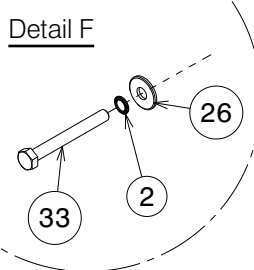
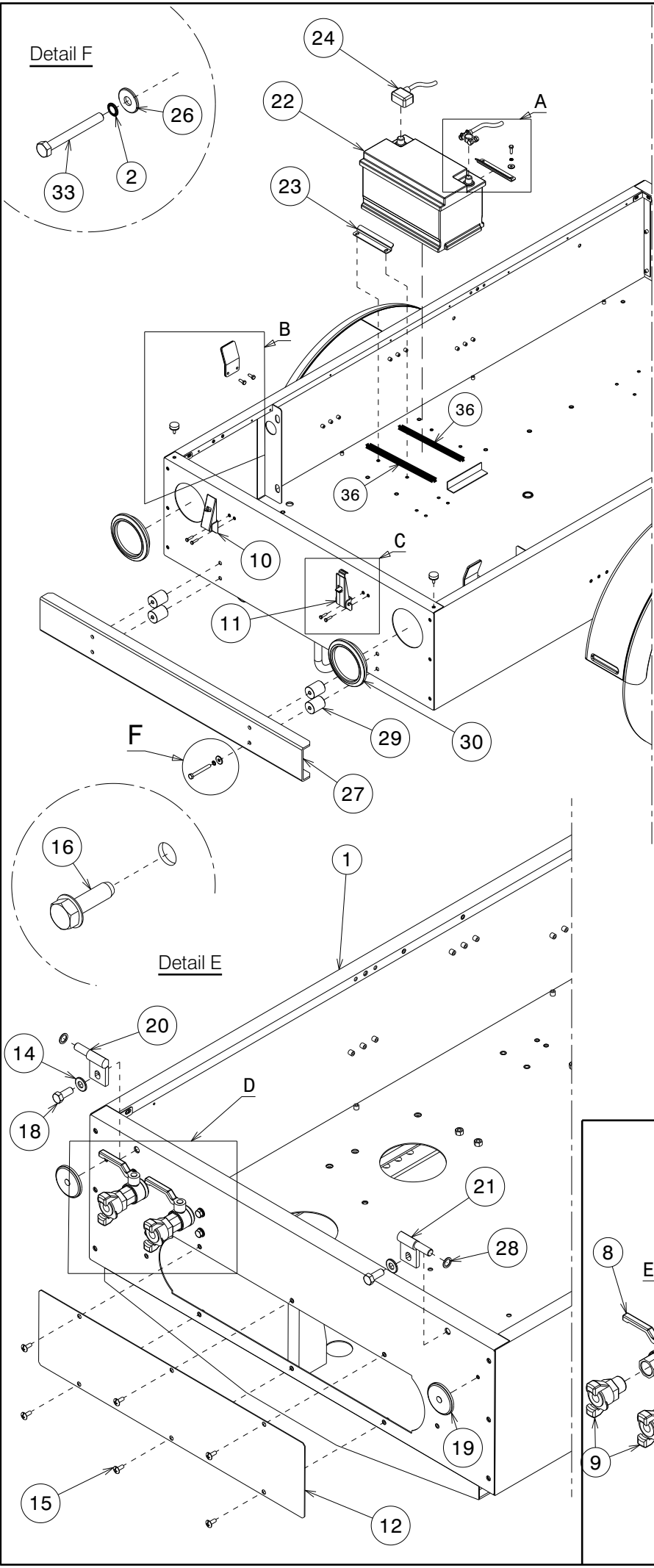



PARTS LIST

Motocompressor – D185T4F

PARTS LEGENDA: Chassis

Tab. 01.2

REF	NAME	CODE	QUANTITY
1	Chassis	038-0525990-S	1
2	Schnorr washer d.8	015-251-S	4
3	Silent block	061-900-S	2
4	Exit valves clamping sleeve	063-106700-S	1
5	Square head plug (1/8")	106-020-S	1
6	Copper washer 33,1x40x2	015-018-S	1
7	Double screw G 1"	187-070-S	1
8	Ball valve	152-030-S	2
9	Bayonet fitting	148-651-S	2
10	Lock with hole	128-0065-S	1
11	Lock without hole	128-006-S	1
12	Front closing panel	124-291-S	1
13	Hexagonal head Screw M6x16 UNI 5739	132-062-S	4
14	Flat washer D.13x27x2,5	015-047-S	2
15	Large head screw M6x16	243-009-S	6
16	Flanged hex head screw	132-10105-S	4
17	Flat washer d.6	015-029-S	8
18	Hexagonal head screw M.12x30 UNI 5739	132-192-S	2
19	White reflector d.60	147-071-S	2
20	Fixed right hinge	007-022-S	1
21	Fixed left hinge	007-023-S	1
22	Battery	174-030-S	1
23	Battery clamp	115-009-S	2
24	Positive battery cable	252-054-S	1
25	Negative battery cable	252-055-S	1
26	Flat washer 8x24x2 UNI6593	015-031-S	4
27	Bumper	032-11763-S	1
28	Copper washer D.14x20x1,5	015-008-S	2
29	Bumper spacer	009-3123-S	4
30	USA Light	142-0050-S	2
31	Centering blade	120-039522-S	2
32	Hex socket head cap screw M6x20	133-092-S	4
33	Hexagonal head screw M8x70 UNI 5739	132-111-S	4
34	Hex head screw . M6x20	132-063-S	4
35	Schnorr washer d.6	015-250-S	8
REF	NAME	CODE	LENGTH
36	Adhesive gasket 20X5	023-351-S	12"
			12"

Detail A

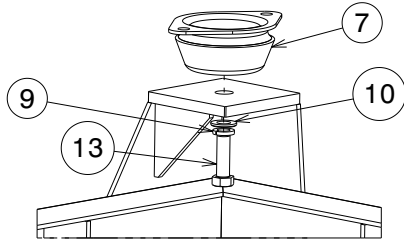

Detail C

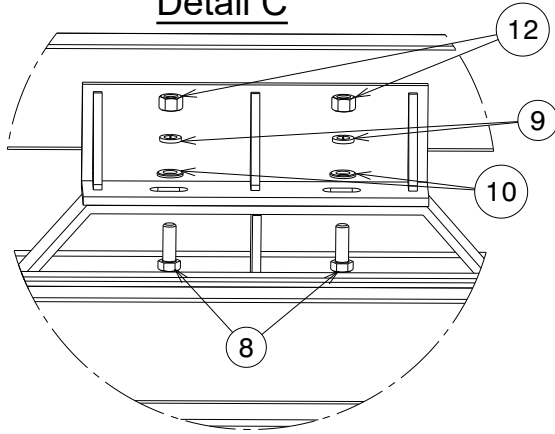

Detail B

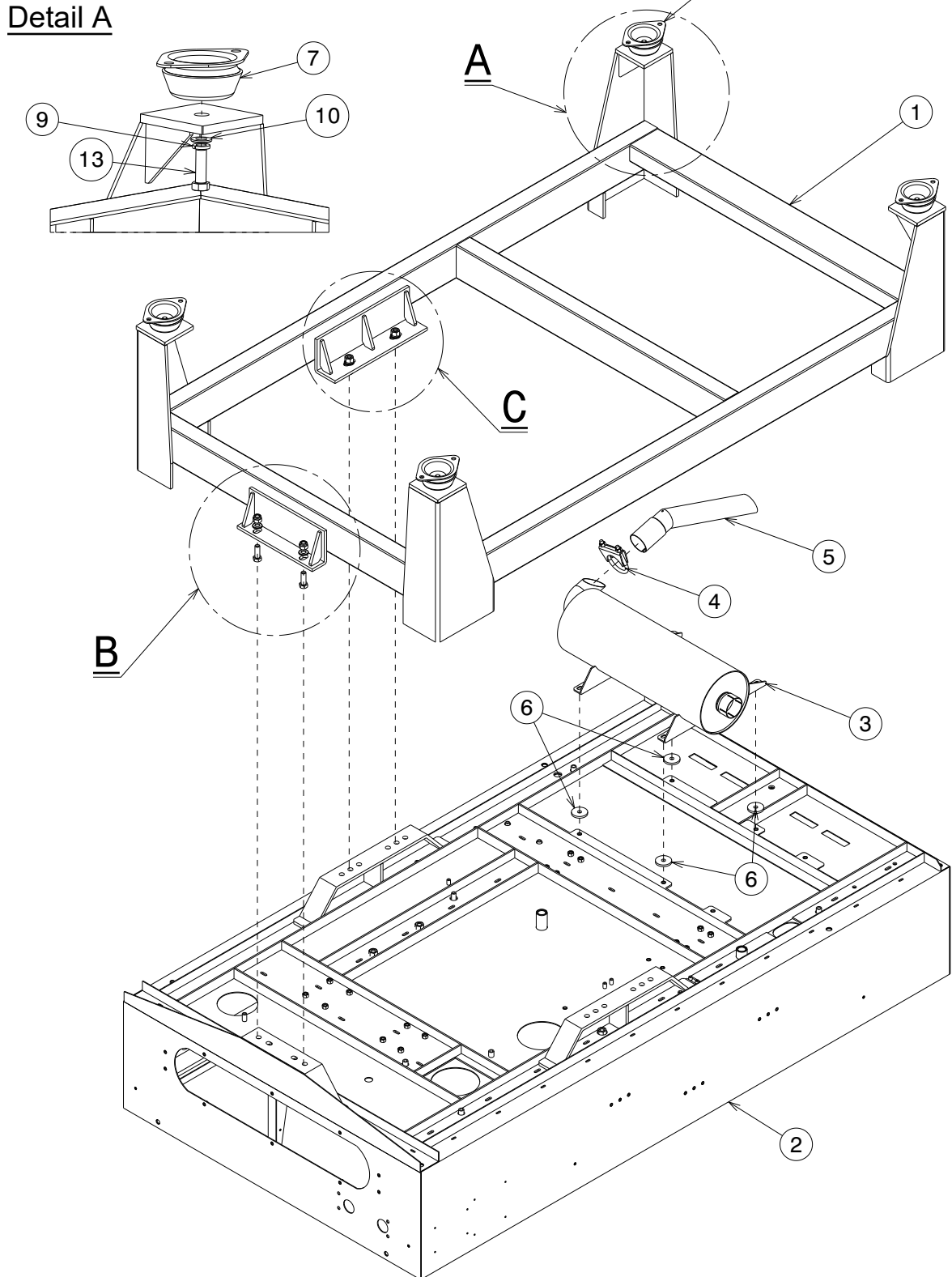
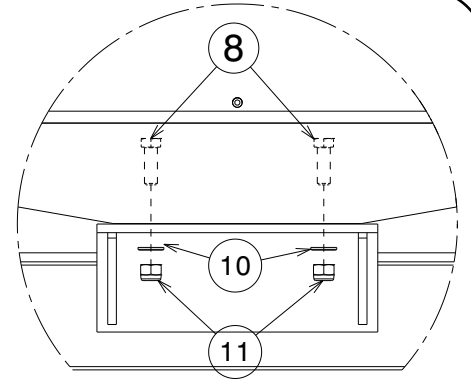



PARTS LIST

Motocompressor – D185T4F

PARTS LEGENDA: Skid subframe

Tab. 01.3

POSITION	DESCRIPTION	PART No.	QUANTITY
1	Skid subframe	038-052601020-S	1
2	Hexagonal head M12x40 screw	132-194-S	4
3	Muffler	042-087801-S	1
4	Pipes clamp d.54x8	149-070-S	1
5	Muffler extension (Skid version)	119-049560-S	1
6	Seal for muffler d.40 th..5	023-077-S	4
7	Silent Block	061-0065-S	4
8	Hexagonal head screw	132-193-S	6
9	Elastic washers	139-060-S	8
10	Flat washer d.13	015-034-S	10
11	Self-locking nut M12	137-060-S	2
12	Hex nut M12 UNI 5587	135-060-S	4

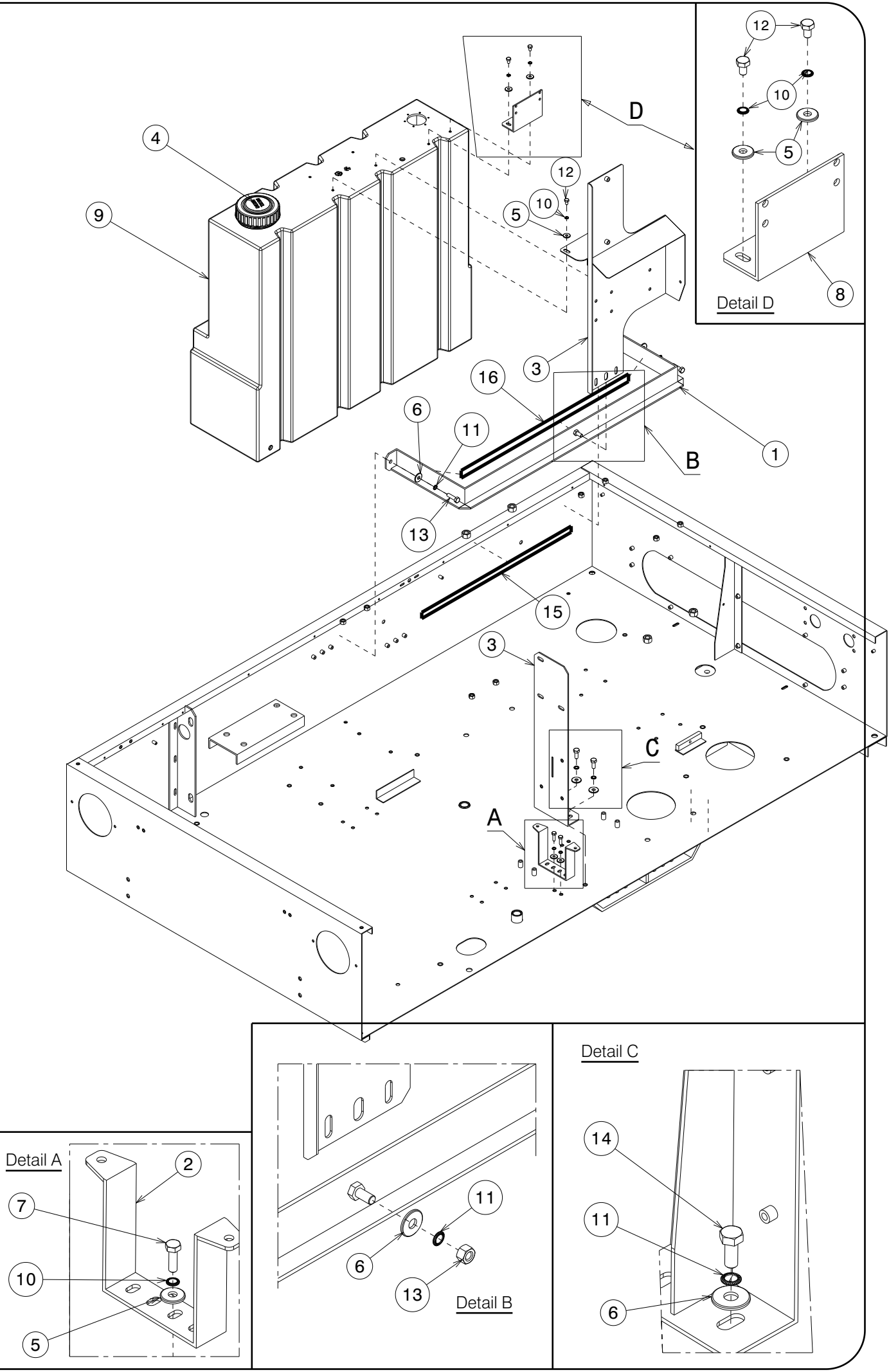



PARTS LIST

Motocompressor – D185T4F

PARTS LEGENDA: Clampings to the chassis

Tab. 01.4

REF	NAME	CODE	QUANTITY
1	Gasoil tank clamping blade	120-35032-S	1
2	Fuses box support blade	120-21977-S	1
3	Control panel support	010-315903-S	1
4	Tank cap	193-0420-S	1
5	Flat washer 6,6X18X2	015-029-S	6
6	Flat washer 8x24x2 UNI6593	015-031-S	6
7	Screw T.E. M6x20	132-063-S	2
8	Valves block support blade	010-3159047-S	1
9	Polyethylene gasoil tank	201-02370-S	1
10	Schnorr washer d.6	015-250-S	6
11	Schnorr washer d.8	015-251-S	5
12	Hex head screw M 6x10	132-060-S	4
13	Hex head screw M8x30	132-103-S	2
14	Screw T.E. M8x20 UNI 5739	132-101-S	2
REF	NAME	CODE	LENGTH
15	Adhesive gasket 20X5	023-351-S	30"
16			47"

Detail A

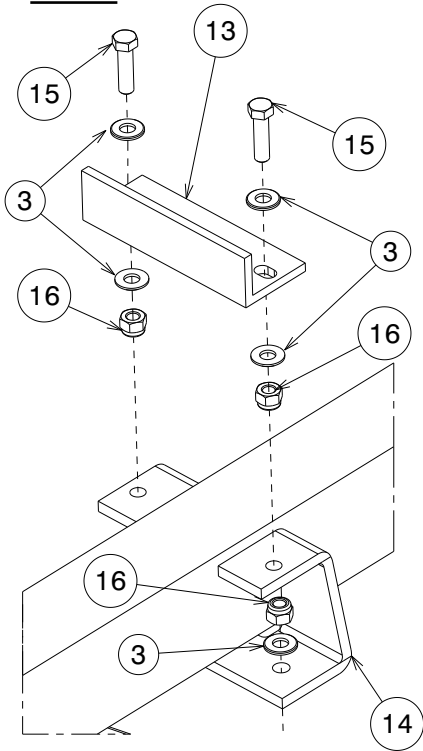

Detail B

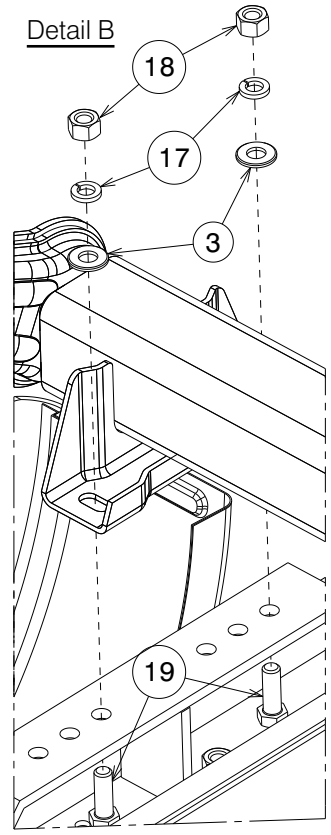

Detail D

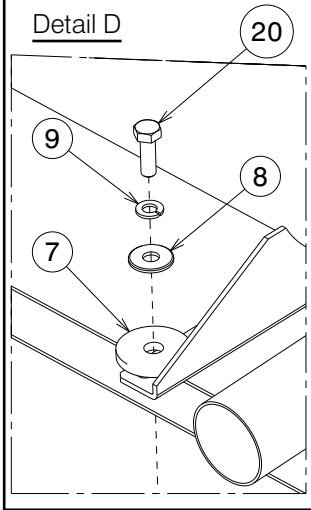

Detail C

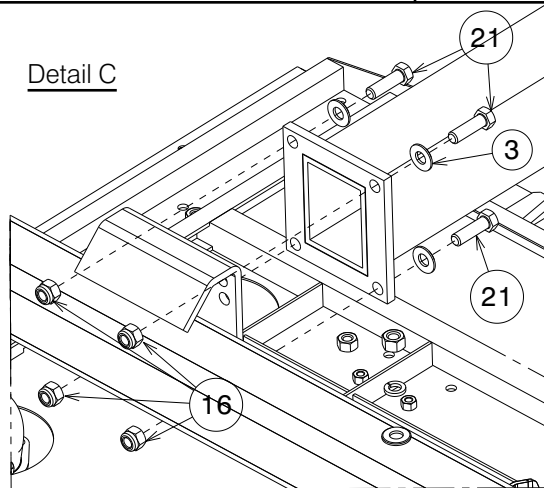

Detail E

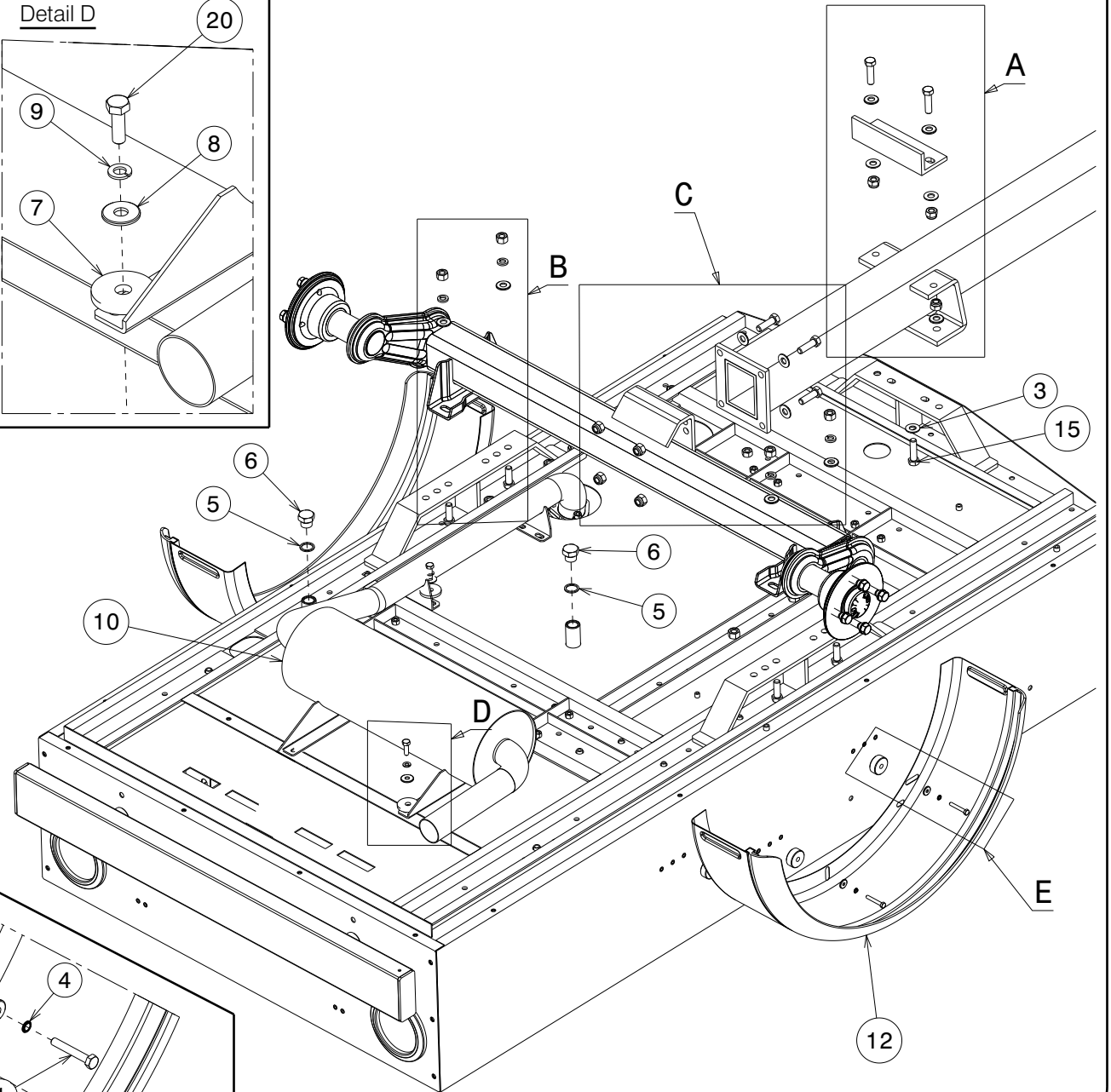
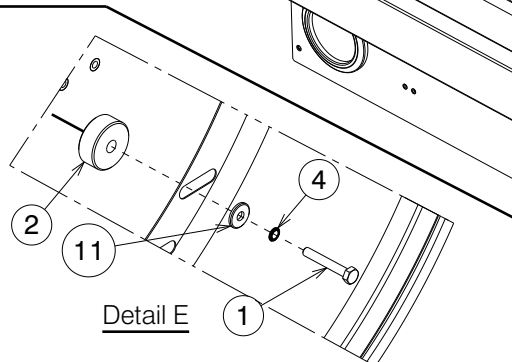



PARTS LIST

Motocompressor – D185T4F

PARTS LEGENDA: Clampings to chassis

Tab. 01.5

REF	NAME	CODE	QUANTITY
1	Screw T.E. M6x40 UNI 5739	132-068-S	6
2	Mudguards spacers	009-312-S	6
3	Flat washer 13x27x2,5	015-047-S	16
4	Schnorr washer d.6	015-250-S	6
5	Copper washer (1/2")	015-0121-S	2
6	Iron plug (1/2")	106-125-S	2
7	Seal for muffler d.40 th..5	023-077-S	4
8	Flat washer 8x24x2 UNI6593	015-031-S	4
9	Elastic washer d.8	139-040-S	4
10	Muffler	042-087801-S	1
11	Washer d. 6.6x18x2	015-029-S	6
12	Mudguards	055-0154-S	2
13	Upper axle clamping section	120-39648101-S	1
14	Lower axle clamping section	120-39648121-S	1
15	Screw T.E. M12x45 UNI 5739	132-195-S	4
16	Self-locking nut M12	137-060-S	8
17	Elastic washer d.12	139-060-S	4
18	Hex nut M12 UNI 5587	135-060-S	4
19	Screw T.E. M12x35 UNI 5739	132-193-S	4
20	Screw T.E. M8x25 UNI 5739	132-102-S	4
21	Screw T.E. M12x40 UNI 5739	132-194-S	4

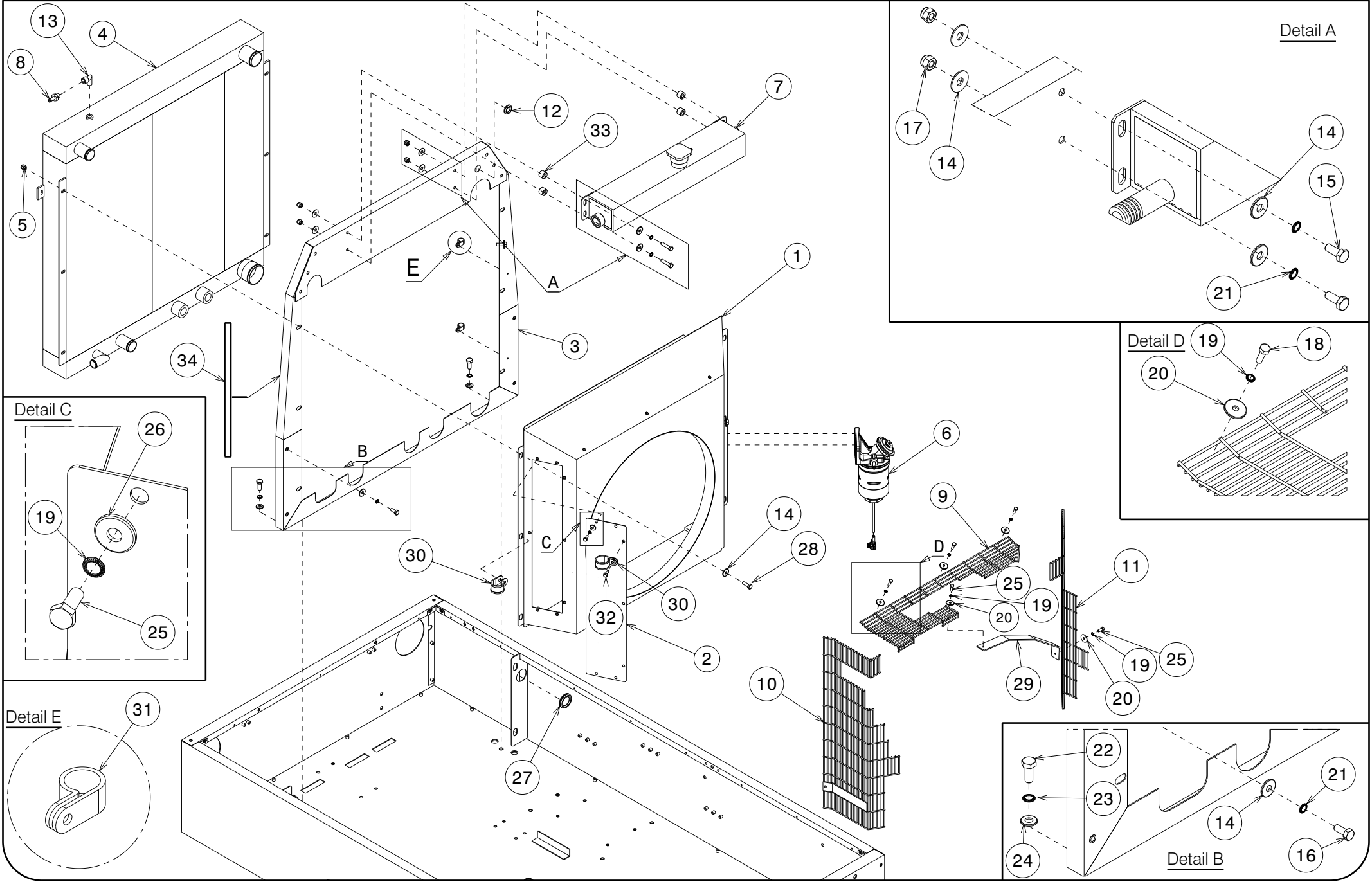



PARTS LIST

Motocompressor – D185T4F

PARTS LEGENDA: Fan cover – Radiator

Tab. 02

REF	NAME	CODE	QUANTITY
1	Fan cover	001-175840-S	1
2	Fan cover panel	124-28520-S	1
3	Radiator support	049-115535-S	1
4	Water-oil radiator	011-10430-S	1
5	Hex nut M8 UNI 7473	137-040-S	6
6	Gasoil filter	191-0950-S	1
7	Compensation tank	201-018505-S	1
8	Fitting (1/4") M for pipe d.8	148-198.2-S	1
9	Upper grid	124-307910-S	1
10	Left side grid	124-307912-S	1
11	Right side grid	124-307914-S	1
12	Diaphragm fairlead	239-016-S	1
13	90° fitting M + F (1/4")	148-143-S	1
14	Flat washer 8x24x2 UNI6593	015-031-S	14
15	Hexagonal head screw M8x30 UNI 5739	132-104-S	4
16	Hex head screw . M8x20 UNI 5739	132-101-S	4
17	Self locking nut M8 UNI 7473	137-040-S	4
18	Hex head screw . M6x20	132-063-S	9
19	Washer d.6	015-250-S	21
20	Flat washer 6x24x2 UNI6593	015-038-S	11
21	Schnorr washer d.8	015-251-S	8
22	Hex head screw M10x25 UNI 5739	132-142-S	2
23	Schnorr washer d.10	015-252-S	2
24	Flat washer 10,2x21x2	015-032-S	2
25	Hexagonal head Screw M6x16 UNI 5739	132-062-S	10
26	Washer d. 6.6x18x2	015-029-S	8
27	Fairlead	239-040-S	1
28	Hex head screw M8x25 UNI 5739	132-102-S	6
29	Fan protection grid support blade	120-3964816-S	1
30	Clamp	149-237-S	2
31	Cable fastener clamp	149-220-S	2
32	Flanged hex head screw 6x20	132-10105-S	4
33	Spacer	009-2320-S	4
REF	NAME	CODE	LENGTH
34	Adhesive gasket 20X5	023-351-S	42"

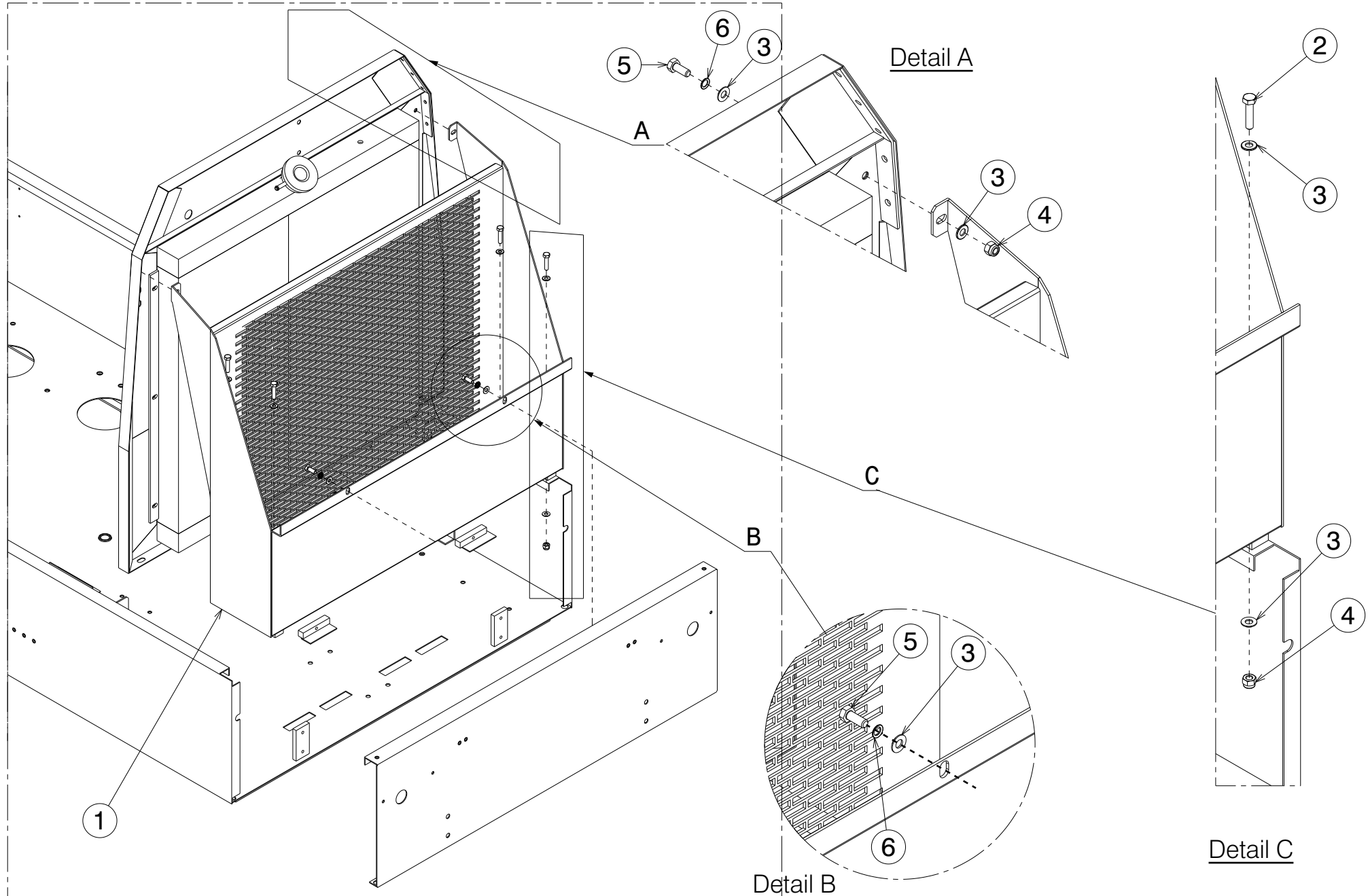



PARTS LIST

Motocompressor – D185T4F

PARTS LEGENDA: Toolbox

Tab. 02.1

REF	NAME	CODE	QUANTITY
1	Toolbox (Up to Serial No.C39008)	029-04951-S	1
	Toolbox (From Serial No.C40726)	029-049511-S	1
2	Hexagonal head screw M8x40	132-105-S	4
3	Washer 8x17	015-030-S	14
4	Self-locking Nut M8	137-040-S	6
5	Hexagonal head screw M8x20	132-101-S	4
6	Schnorr washer d.8	015-251-S	2

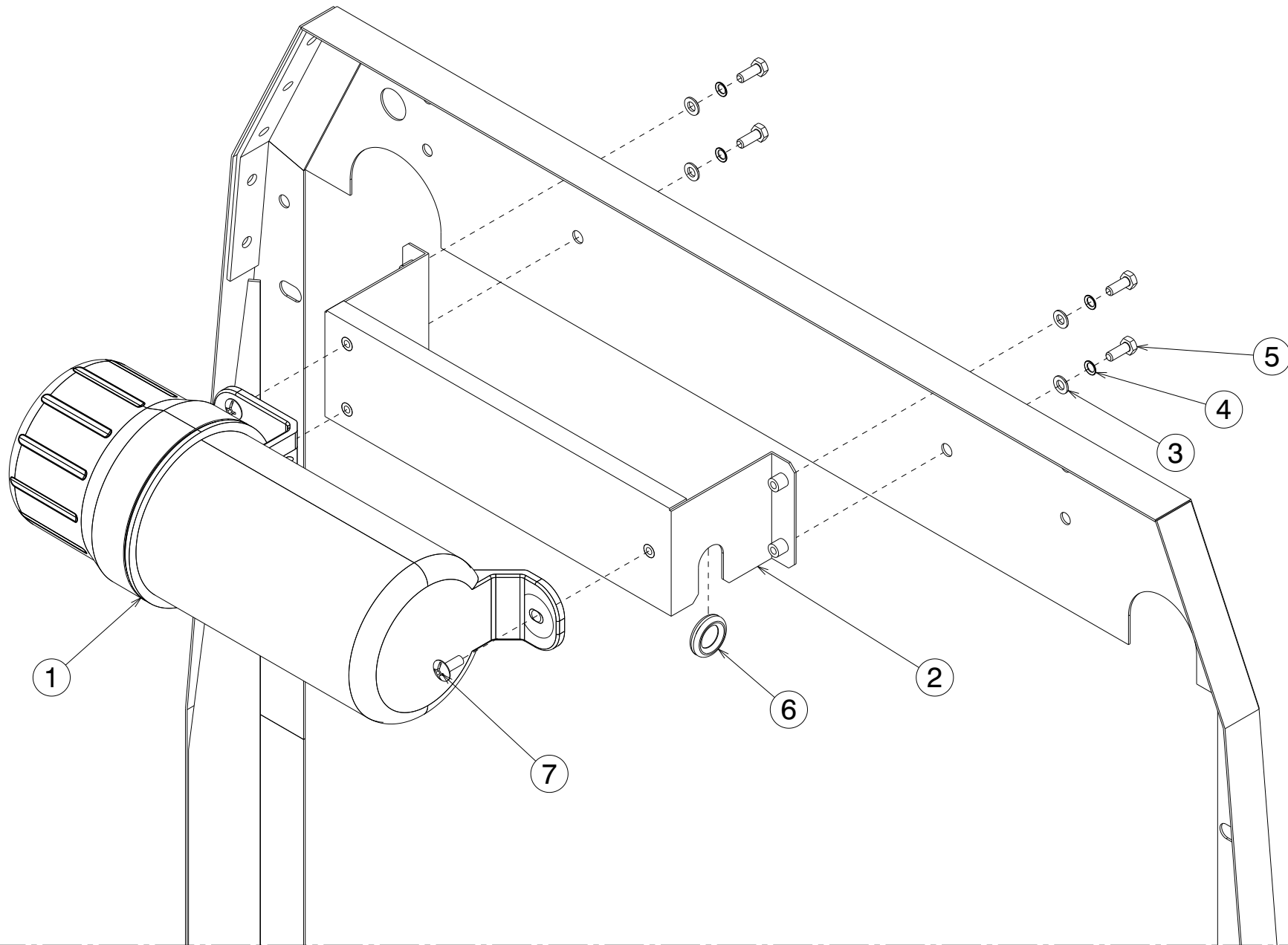



PARTS LIST

Motocompressor – D185T4F

PARTS LEGENDA: Document holder

Tab. 02.2

REF	NAME	CODE	QUANTITY
1	Document holder box	029-3010-S	1
2	Document holder box support	010-3159156-S	1
3	Flat washer 6,6x12x1,5 DIN125/1	015-027-S	4
4	Washer d.6	015-250-S	4
5	Hex head screw M6x16	132-062-S	4
6	Fairlead	239-016-S	2
7	Large head screw M6x16	243-009-S	3

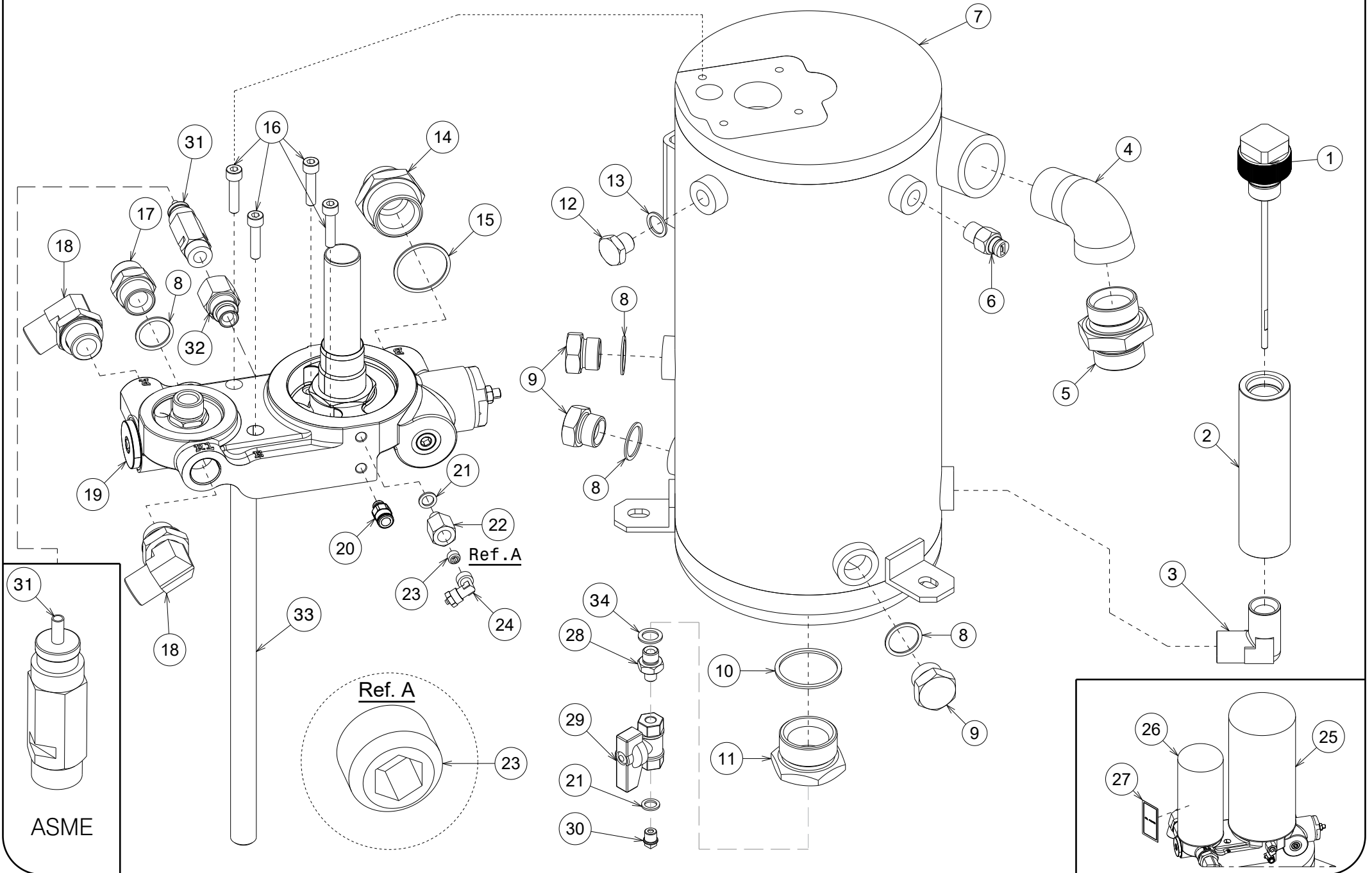



PARTS LIST

Motocompressor – D185T4F

PARTS LEGENDA: Separator tank

Tab. 03

REF	NAME	CODE	QUANTITY
1	Oil level rod plug	106-01060-S	1
2	Oil sleeve	063-1205-S	1
3	Conical 90° M+M adapter coupling ($\frac{3}{4}$ ")	148-287.35-S	1
4	Short radius curve M+F (1 $\frac{1}{4}$ ")	111-060-S	1
5	Double screw (1 $\frac{1}{4}$ ")	187-0852-S	1
6	Compressor thermal contact 115'	103-008-S	1
7	ASME Separator tank (20 lt – 5.30 gal)	037-056825-S	1
8	Copper washer ($\frac{3}{4}$ ")	015-015-S	4
9	Male hexagonal head iron plug ($\frac{3}{4}$ ")	106-130-S	3
10	Copper washer (1 $\frac{1}{2}$ ")	015-019.1-S	1
11	Reduction M 1"1/2 - F 1/4"	190-0845-S	1
12	Male hexagonal head iron plug (M16x1.5)	106-100-S	1
13	Copper washer (d. 16.2x22x1.5)	015-009-S	1
14	Double screw (1 – 1 $\frac{1}{4}$ ")	187-075-S	1
15	Copper washer (1 $\frac{1}{4}$ ")	015-019-S	1
16	Screw TC.E.I (M8x35)	133-135-S	4
17	Double screw ($\frac{3}{4}$ ")	187-060-S	1
18	90° fitting M+M ($\frac{3}{4}$ ")	148-2985-S	2
19	Valve assembly	024-021530-F	1
20	Straight quick coupling (1/8") for pipe d.8	148-577-S	1
21	Copper washer (1/8")	015-005-S	2
22	Extension F+M L=30 ($\frac{1}{4}$ " – 1/8")	189-302-S	1
23	S.T screw with conical hexagon (1/8")	218-0012-S	1
24	Elbow fitting ($\frac{1}{4}$ ") for pipe d.6	148-090-S	1
25	Separator filter	157-171-S	1
26	Compressor oil filter P<10 bar	099-008-S	1
27	Oil filter sticker	238-002-S	1
28	Double screw $\frac{1}{4}$ - 1/8	187-002-S	1
29	Ball valve (1/8")	152-005-S	1
30	Square head plug (1/8")	106-020-S	1
31	Safety valve (ASME)	033-059-S	1
32	Reduction 1/2F to 3/8M l=33	190-1512-S	1
33	Draft pipe	064-1030-S	1
34	Copper washer $\frac{1}{4}$ "	015-007-S	1

Detail C

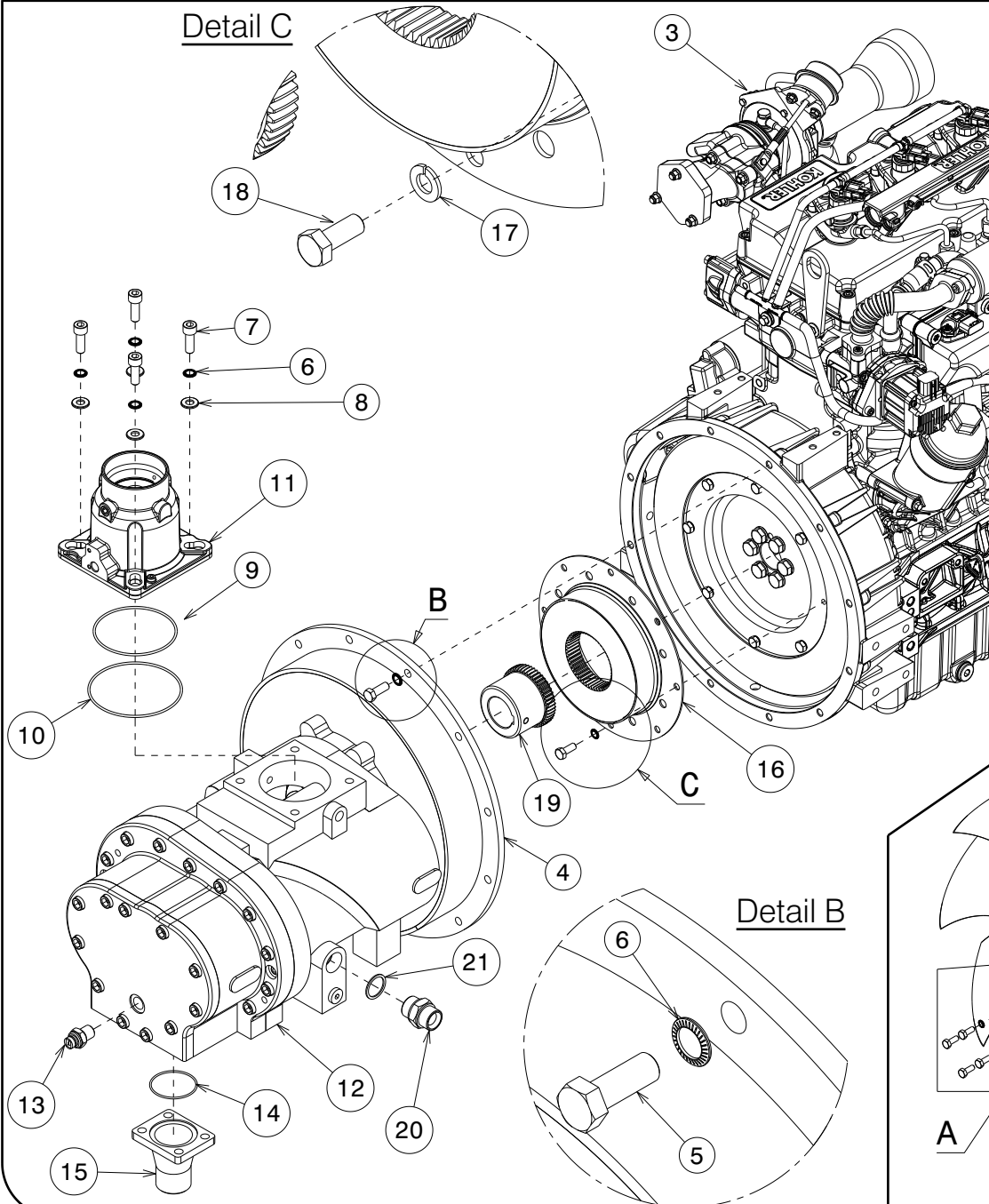

Detail A

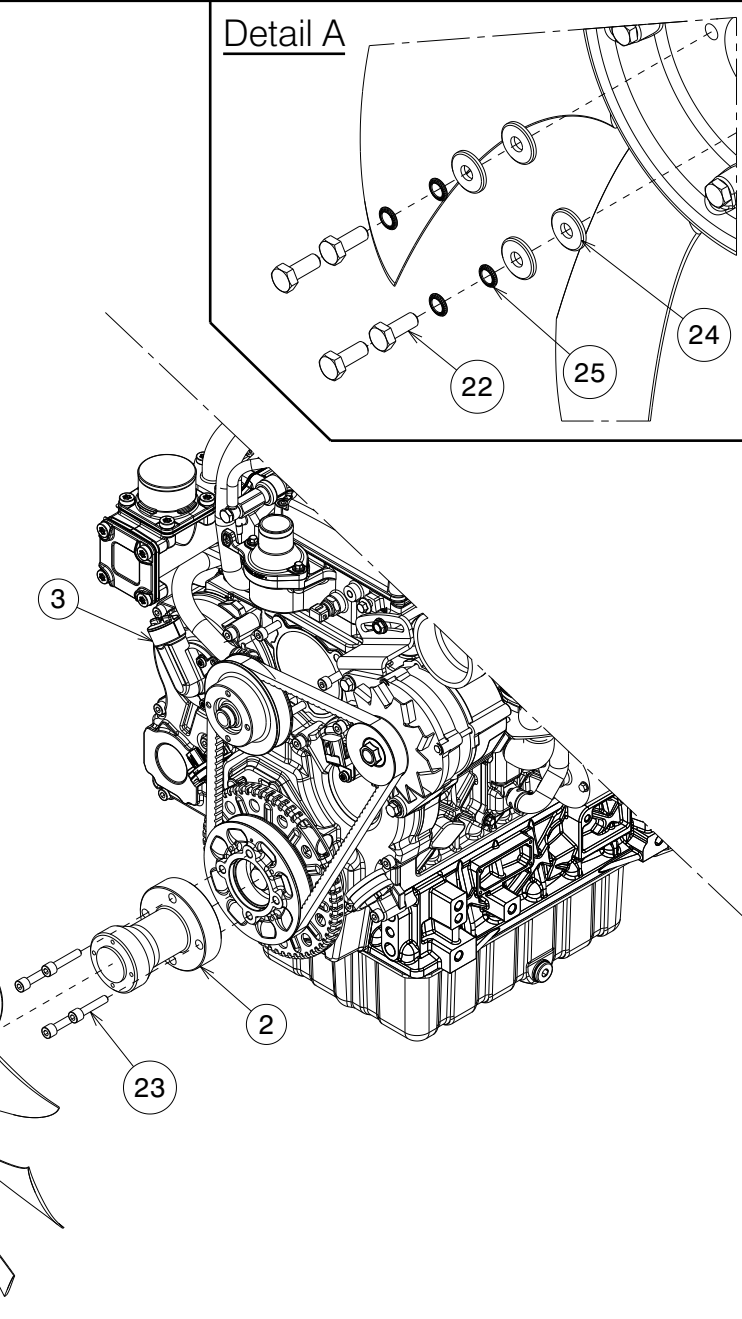



PARTS LIST

Motocompressor – D185T4F

PARTS LEGENDA: Engine – Air end

Tab. 04.1

REF	NAME	CODE	QUANTITY
1	Fan (From Serial No.C40401)	083-14133-S	1
2	Fan support (From Serial No.C40401)	028-08351-S	1
	Fan support (Up to Serial No.C40400)	028-0835-S	1
3	Engine	165-42492-S	1
4	Fly wheel housing	020-089310-S	1
5	Hexagonal head screw 3/8-16 UNC L=1	132-701-S	12
6	Schnorr washer d.10	015-252-S	16
7	Hex socket head cap screw M10 x 30	133-183-S	4
8	Plane washer	015-032-S	4
9	OR seal 3375	023-3035-S	1
10	OR seal 3425	023-2885-S	1
11	Regulator	024-138181-F	1
12	Air end	024-032914614-F	1
13	Thermal contact	103-0125-S	1
14	OR seal 3206	023-067-S	1
15	Flex clamping flange	004-0695-S	1
16	KTR Engine joint	006-10800-S	1
17	Grover washer d.8	139-040-S	4
18	Hexagonal head screw 5/16-18 UNC L=20mm	132-70180-S	8
19	KTR air end joint	006-10802-S	1
20	Double screw 3/4 hole 19,1 Din standard	187-060-S	1
21	Copper washer (3/4")	015-015-S	1
22	Hexagonal head Screw M6x20 UNI 5739	132-063-S	4
23	Hex socket head cap screw M10x 40	133-137-S	4
24	Washer d. 6.6x18x2	015-029-S	4
25	Schnorr washer d.6	015-250-S	4

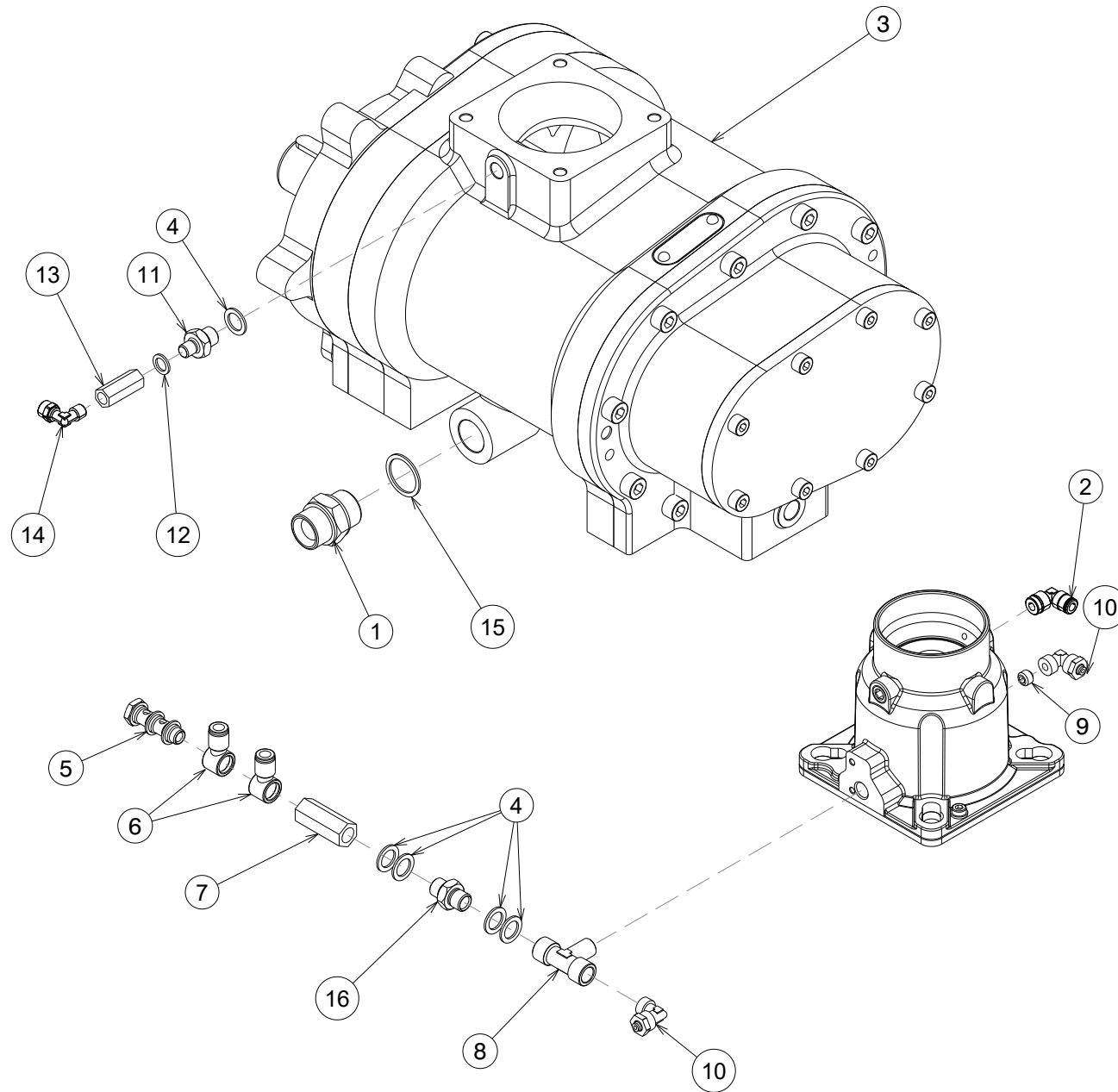



PARTS LIST

Motocompressor – D185T4F

PARTS LEGENDA: Pneumatic Regulation system

Tab. 04.2

REF	NAME	CODE	QUANTITY
1	Double screw G 3/4"	187-060-S	1
2	Quick coupling 90° (1/4") for pipe d.8	148-573.5-S	1
3	Air end assembly	024-032914614-F	1
4	Copper washer (1/4")	015-007-S	5
5	Quick coupling (1/4")	148-59005-S	1
6	Super quick coupling (1/4")	148-5901-S	2
7	Non return valve (1/4")	033-017-S	1
8	T fitting F+M+F (1/4")	148-194-S	1
9	S.T screw with hexagon (1/8")	218-001-S	1
10	90° fitting (1/4") for pipe d. 8	148-110-S	2
11	Double screw (1/4" – 1/8")	187-002-S	1
12	Copper washer (1/8")	015-005-S	2
13	Non-return valve (1/8")	033-001-S	1
14	90° fitting (1/8") for pipe d.6	148-080-S	1
15	Copper washer	015-015-S	1
16	Double screw 1/4"	187-005-S	1

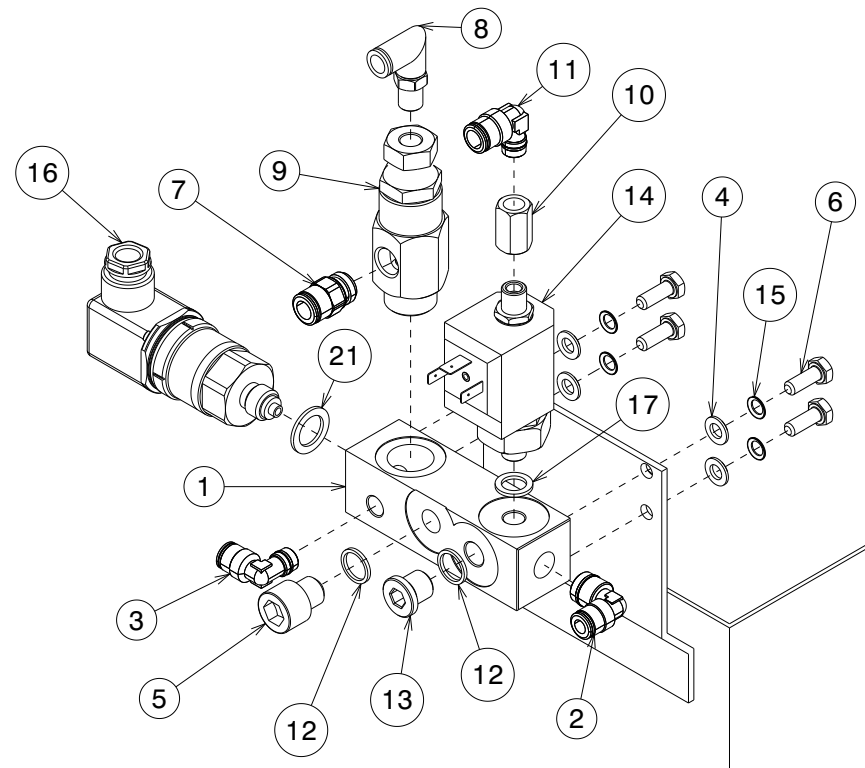
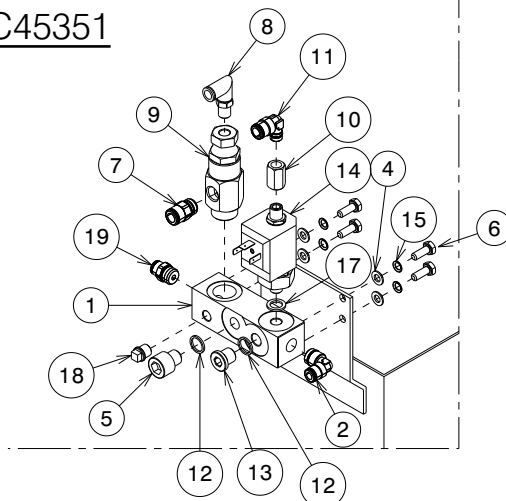
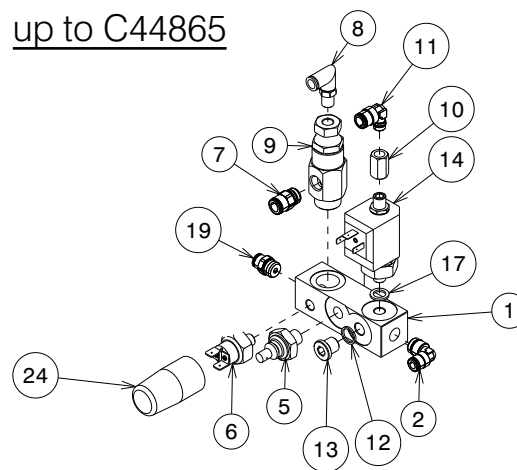
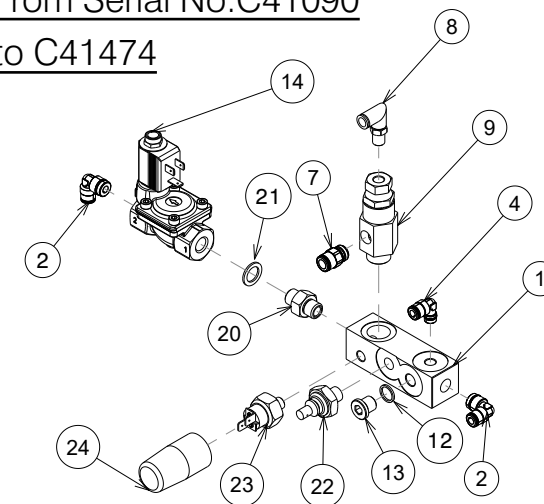
A - From Serial No.C45352B - From Serial No.C44866
up to C45351C - From Serial No.C41475
up to C44865D - From Serial No.C41090
up to C41474



PARTS LIST

Motocompressor – D185T4F

PARTS LEGENDA: Pneumatic Regulation system

Tab. 04.2.1

REF	NAME	CODE	QUANTITY
A - From Serial No.C45352			
1	Devices coupling block	053-300-S	1
2	Quick coupling 90° (1/4") for pipe d.8	148-573.5-S	1
3	90° quick coupling (1/8") for pipe d.6	148-570-S	1
4	Flat washer 6,6x12x1,5 DIN125/1	015-027-S	4
5	Hex socket head cap screw M12x12	133-2285-S	1
6	Hexagonal head Screw M6x16 UNI 5739	132-062-S	4
7	Straight quick coupling (1/4") for pipe d.8	148-575-S	1
8	Straight quick coupling (1/8")	148-8001-S	1
9	Pressure regulation valve assembly(Up to S/N C37341)	024-032.1-F	1
	Pressure regulation valve assembly(From S/N C38470)	024-0323-F	1
10	Spacer 20 D. 1/8"	009-014-S	1
11	Quick coupling 90° (1/8") for pipe d.8	148-572-S	1
12	Copper washer int. d. 12.2	015-006-S	2
13	Built-in hexagonal head plug M12x1.5	106-092-S	1
14	Solenoid valve (From S/N C41475)	160-052-S	1
15	Washer d.6	015-250-S	4
16	Pressure transducer	205-030-S	1
17	Copper washer (1/8")	015-005-S	1
21	Copper washer (1/4")	015-007-S	1
B - From Serial No.C44866 up to C45351			
REF	NAME	CODE	QUANTITY
1	Devices coupling block	053-300-S	1
2	Quick coupling 90° (1/4") for pipe d.8	148-573.5-S	1
4	Flat washer 6,6x12x1,5 DIN125/1	015-027-S	4
5	Hex socket head cap screw M12x12	133-2285-S	1
6	Hexagonal head Screw M6x16 UNI 5739	132-062-S	4
7	Straight quick coupling (1/4") for pipe d.8	148-575-S	1
8	Straight quick coupling (1/8")	148-8001-S	1
9	Pressure regulation valve assembly(Up to S/N C37341)	024-032.1-F	1
	Pressure regulation valve assembly(From S/N C38470)	024-0323-F	1
10	Spacer 20 D. 1/8"	009-014-S	1
11	Quick coupling 90° (1/8") for pipe d.8	148-572-S	1
12	Copper washer int. d. 12.2	015-006-S	2
13	Built-in hexagonal head plug M12x1.5	106-092-S	1
14	Solenoid valve (From S/N C41475)	160-052-S	1
15	Washer d.6	015-250-S	4
17	Copper washer (1/8")	015-005-S	1
18	Square head plug (1/8")	106-020-S	1
19	Straight quick coupling (1/4") for pipe d.6	148-574-S	1
31	Copper washer int. d. 12.2	015-006-S	1
34	Straight quick coupling (1/4") for pipe d.6	148-574-S	1



PARTS LIST

Motocompressor – D185T4F

PARTS LEGENDA: Pneumatic Regulation system

Tab. 04.2.1

<u>C - From Serial No.C41475 up to C44865</u>			
REF	NAME	CODE	QUANTITY
1	Devices coupling block	053-300-S	1
2	Quick coupling 90° (1/4") for pipe d.8	148-573.5-S	1
7	Straight quick coupling (1/4") for pipe d.8	148-575-S	1
8	Straight quick coupling (1/8")	148-8001-S	1
9	Pressure regulation valve assembly(Up to S/N C37341)	024-032.1-F	1
	Pressure regulation valve assembly(From S/N C38470)	024-0323-F	1
10	Spacer 20 D. 1/8"	009-014-S	1
11	Quick coupling 90° (1/8") for pipe d.8	148-572-S	1
12	Copper washer int. d. 12.2	015-006-S	1
13	Built-in hexagonal head plug M12x1.5	106-092-S	1
14	Solenoid valve (From S/N C41475)	160-052-S	1
17	Copper washer (1/8")	015-005-S	1
19	Straight quick coupling (1/4") for pipe d.6	148-574-S	1
31	Copper washer int. d. 12.2	015-006-S	1
<u>D - From Serial No.C41090 up to C41474</u>			
REF	NAME	CODE	QUANTITY
1	Devices coupling block	053-300-S	1
2	Quick coupling 90° (1/4") for pipe d.8	148-573.5-S	2
7	Straight quick coupling (1/4") for pipe d.8	148-575-S	1
8	Straight quick coupling (1/8")	148-8001-S	1
9	Pressure regulation valve assembly(Up to S/N C37341)	024-032.1-F	1
	Pressure regulation valve assembly(From S/N C38470)	024-0323-F	1
12	Copper washer int. d. 12.2	015-006-S	1
13	Built-in hexagonal head plug M12x1.5	106-092-S	1
14	Solenoid valve (Up to S/N C41474)	160-0871-S	1
20	Double screw G 1/4"	187-006-S	1
31	Copper washer int. d. 12.2	015-006-S	1
21	Copper washer (1/4")	015-007-S	1
22	Oil pressure switch 1,4bar	154-030-S	1
23	Oil pressure switch 3,5bar	150-025-S	1
24	Oil pressure switch cap	284-020-S	1

This page has been intentionally left blank

From Serial No.C44866

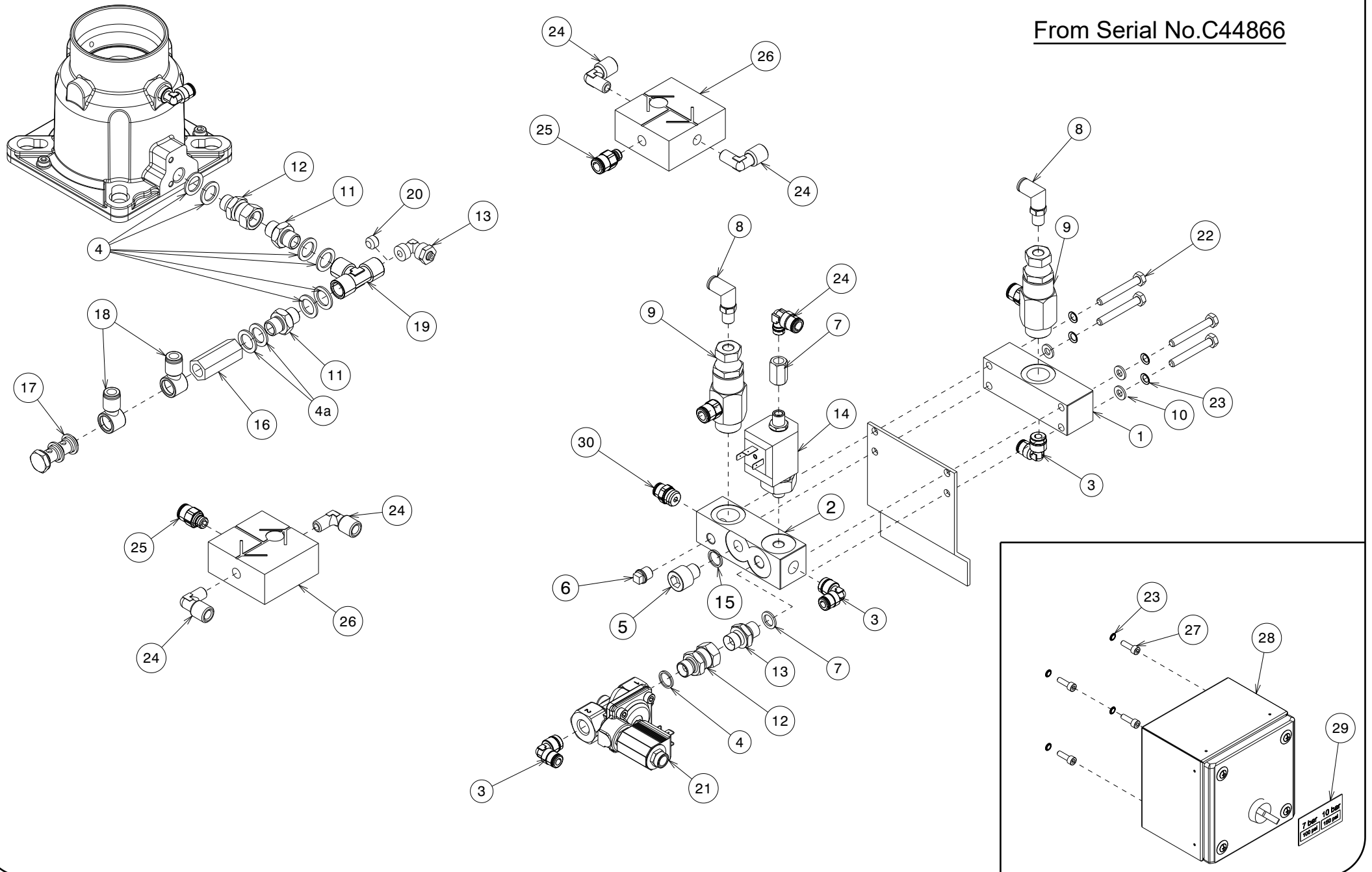



PARTS LIST

Motocompressor – D185T4F

PARTS LEGENDA: Pneumatic Regulation system
Double pressure version

Tab. 04.3

REF	NAME	CODE	QUANTITY
2	Devices coupling block	053-300-S	1
3	Quick coupling 90° (1/4") for pipe d.8	148-573.5-S	1
4	Copper washer 1/4"	015-007-S	7
5	Hex socket head cap screw M12x12	133-2285-S	1
6	Square head plug (1/8")	106-020-S	1
7	Copper washer 1/8"	015-005-S	1
8	Straight quick coupling (1/8")	148-8001-S	1
9	Pressure regulation valve assembly	024-0323-F	1
11	Double screw (1/4")	187-005-S	2
12	Straight adapter coupling M+F rotating (1/4")	148-003.2-S	1
13	90° fitting (1/4") for pipe d. 8	148-110-S	1
14	Solenoid valve	160-052-S	1
15	Copper washer int. d. 12.2	015-006-S	1
17	Quick coupling (1/4")	148-59005-S	1
18	Super quick coupling (1/4")	148-5901-S	2
19	T fitting F+F+F (1/4")	148-142-S	1
20	Hex head screw with hexagon (1/8")	218-0012-S	1
24	Quick coupling 90° (1/8") for pipe d.8	148-572-S	1
30	Straight fitting (1/4") for pipe d. 6	148-574-S	1
DOUBLE PRESSURE CONVERSION KIT			
REF	NAME	CODE	QUANTITY
1	Devices coupling block	053-3005-S	1
3	Quick coupling 90° (1/4") for pipe d.8	148-573.5-S	2
4	Copper washer 1/4"	015-007-S	1
4a	Copper washer 1/4"(replace in case of breakage during disassembly)	015-007-S	2
7	Copper washer 12x18x1,5 (replace in case of breakage during disassembly)	015-006-S	1
8	Straight quick coupling (1/8")	148-8001-S	1
9	Pressure regulation valve assembly	024-0323-F	1
10	Plane washer 6x12	015-027-S	4
12	Straight adapter coupling M+F rotating (1/4")	148-003.2-S	1
13	Double screw M12x1.5 – 1/4"	187-049-S	1
16	1/4" non-return valve (Replace 033-017-S standard version valve)	033-0178-S	1
21	Solenoid valve	160-0871-S	1
22	Hex head screw M6x45	132-069-S	4
23	Schnorr washer d.6	015-250-S	8
24	Quick coupling 90° (1/8") for pipe d.8	148-572-S	4
25	Straight quick coupling (1/8") per tubo d.8	148-577-S	2
26	Pneumatic valve OR	033-0850-S	2
27	Hex socket head cap screw M6x20	133-092-S	4
28	Electrical box and harness	269-5480-S	1
29	"Double pressure 7 – 10 bar" sticker	238-0465-S	1
--	Rylsan pipe d.8x6	089-0705-S	L = 6,50 ft

Replace 033-017-S non return valves
with 033-0178-S

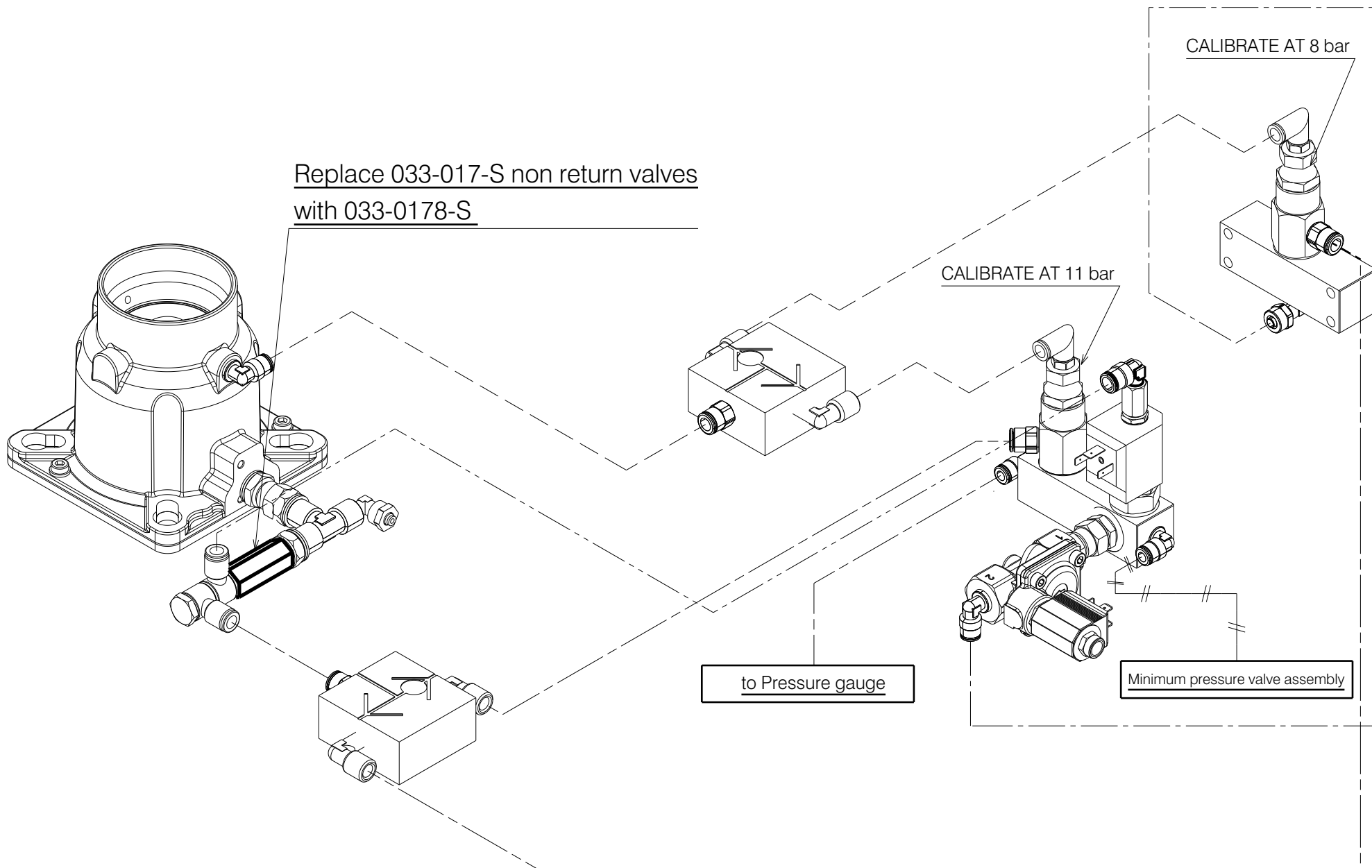

This page has been intentionally left blank

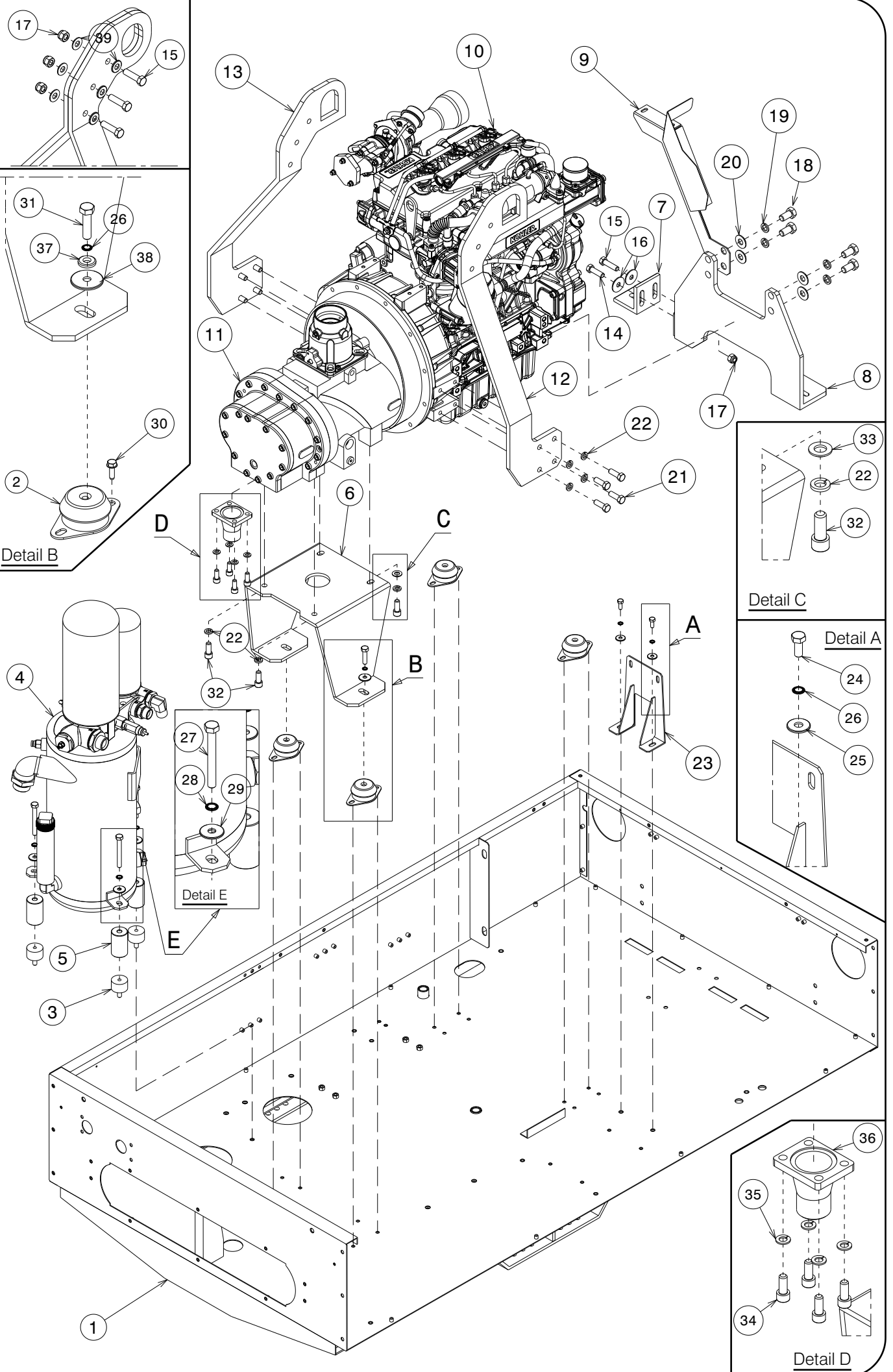



PARTS LIST

Motocompressor – D185T4F

PARTS LEGENDA: Clampings to the frame

Tab. 05

REF	NAME	CODE	QUANTITY
1	Chassis (Up to serial No. C42374)	038-05260001-S	1
	Chassis (From serial No. C42375 – Up to C44380)	038-05260003-S	1
	Chassis (From serial No. C44381)	038-0525990-S	1
2	Silent Block	061-02370-S	4
3	Silent Block	061-0570-S	3
4	Separator tank assembly	024-6149025-F	1
5	Separator tank spacer	009-12270-S	3
6	Compressor support	027-0901-S	1
7	Engine support L-swinging	039-1153-S	1
8	Engine support	039-115430-S	1
9	Intercooler (OUT) clamping blade	120-3964802-S	1
10	Engine	165-42492-S	1
11	Air end	024-032914614-F	1
12	Right hoisting hook	017-0478505-S	1
13	Left hoisting hook	017-0478525-S	1
14	Hex head screw M12x40 UNI 5739	132-194-S	1
15	Hex head screw M12x45 UNI 5739	132-195-S	4
16	Flat washer d.12,5x40x3	015-0405-S	2
17	Self-locking nut M12	137-060-S	4
18	Hexagonal head screw M.16x40	132-294-S	4
19	Elastic washers d. 16	139-080-S	4
20	Plane washer d. 16x35x3	015-048-S	4
21	Hex head screw M12x35 UNI 5739	132-193-S	8
22	Elastic washer	139-060-S	8
23	Intercooler (IN) clamping blade	120-3964800-S	1
24	Hex head screw . M8x20 UNI 5739	132-101-S	2
25	Flat washer 8x24x2 UNI6593	015-031-S	2
26	Schnorr washer d.8	015-251-S	8
27	Hex head screw partially threaded M.10x 80	132-153-S	3
28	Schnorr washer d.10	015-252-S	3
29	Flat washer 10x30x2,5 UNI6593	015-033-S	5
30	Flanged hex head screw M8x20	132-10105-S	8
31	Hex head screw M.10x40 UNI 5739	132-145-S	4
32	Hex socket head cap screw M12x30	133-233-S	4
33	Flat washer d.13	015-034-S	2
34	Hex socket head cap screw M10x25	133-182-S	4
35	Elastic washer	139-050-S	4
36	Flex clamping flange	004-0695-S	1
37	Flat washer d.10x22x4	015-0325-S	4
38	Flat washer d.10x40x2.5	015-037-S	4
39	Flat washer 13x27x2,5	015-047-S	6

Detail B

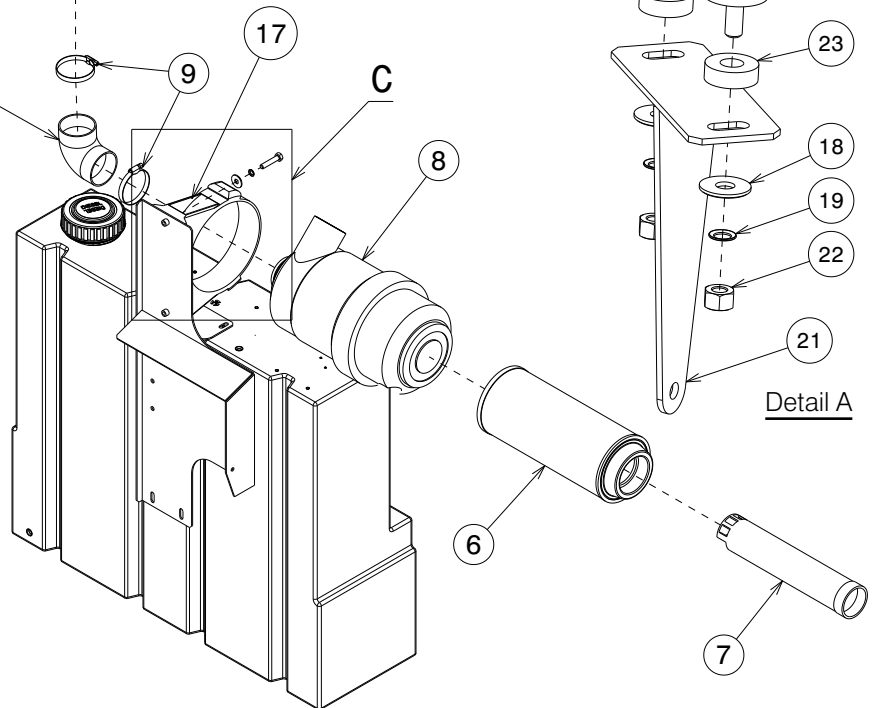
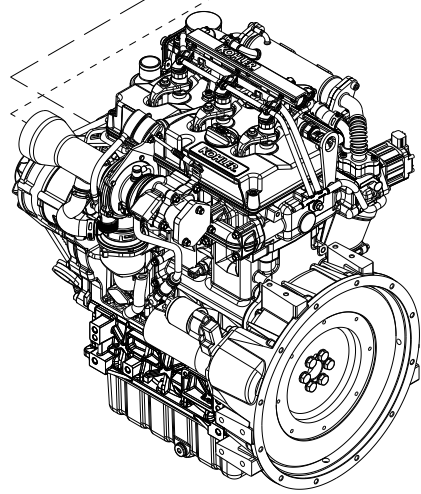
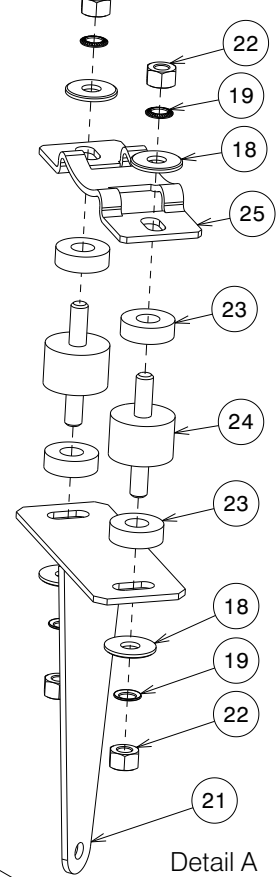
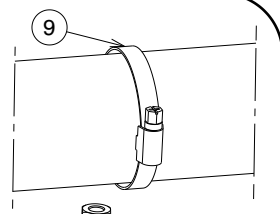
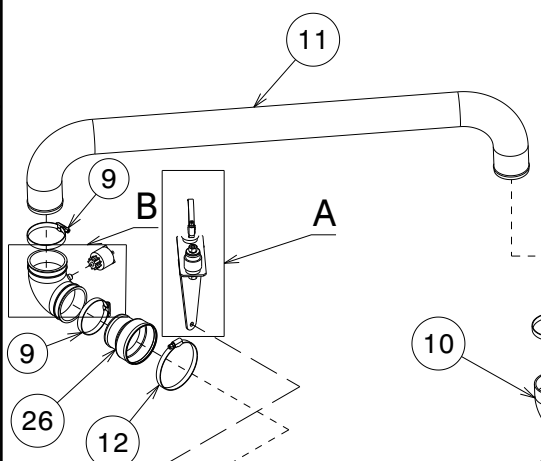
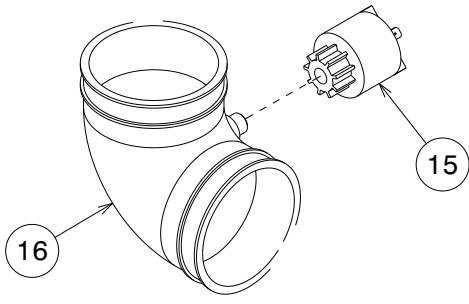

Detail C

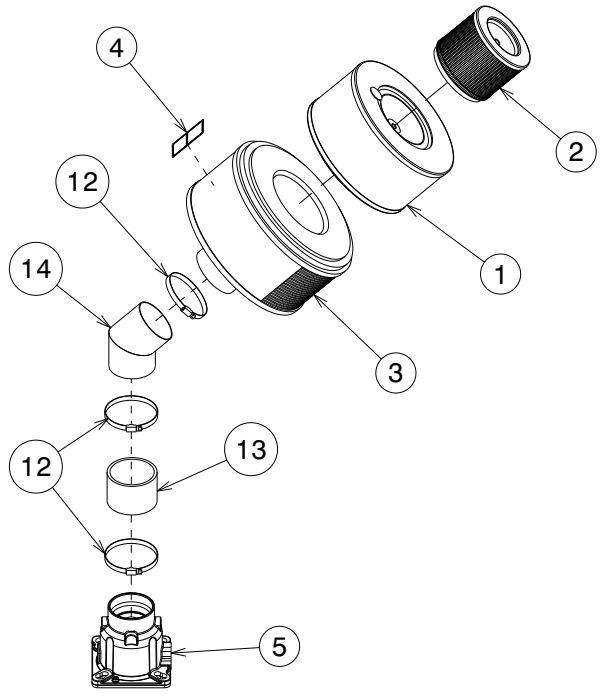
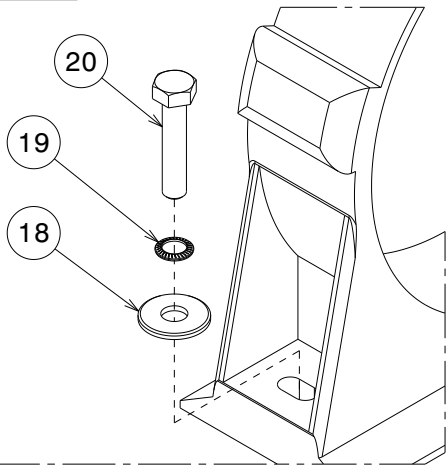



PARTS LIST

Motocompressor – D185T4F

PARTS LEGENDA: Air intake

Tab. 06

REF	NAME	CODE	QUANTITY
1	1° Air filter – Comp.	162-576-S	1
2	2° Air filter – Comp.	162-577-S	1
3	Air cleaner - Compressor	014-28962-S	1
4	Air filter sticker	238-001-S	1
5	Regulator assembly	024-138181-F	1
6	1° Air filter – Engine	162-0086-S	1
7	2° Air filter – Engine	162-0087-S	1
8	Air cleaner – Engine	014-4221-S	1
9	Pipe clamp d. 50x70	149-1420-S	4
10	Curve d. 60	111-106-S	2
11	Engine inlet pipe	064-16804045-S	1
12	Pipe clamp d.70x90	149-145-S	3
13	Pipe d.76	089-05630-S	1
14	Air filter inlet curve	111-10125-S	1
15	Air filter clogging sensor	257-0470-S	1
16	90° silicone elbow (Up to serial No.C40000)	111-10590-S	1
17	Mann air filter support	010-2418-S	1
18	Flat washer 8x24x2 UNI6593	015-031-S	4
19	Schnorr washer d.8	015-251-S	2
20	Hex head screw M8x40 UNI 5739	132-105-S	2
21	Pipe clamping blade	120-39648045-S	1
22	Hex nut M8 UNI 5587	135-040-S	4
23	Spacer	009-0875-S	4
24	Silent block	061-013-S	2
25	Clamp support	010-1530-S	1
26	Reduction 75 to 60 (From to serial No.C40000)	190-60454-S	1

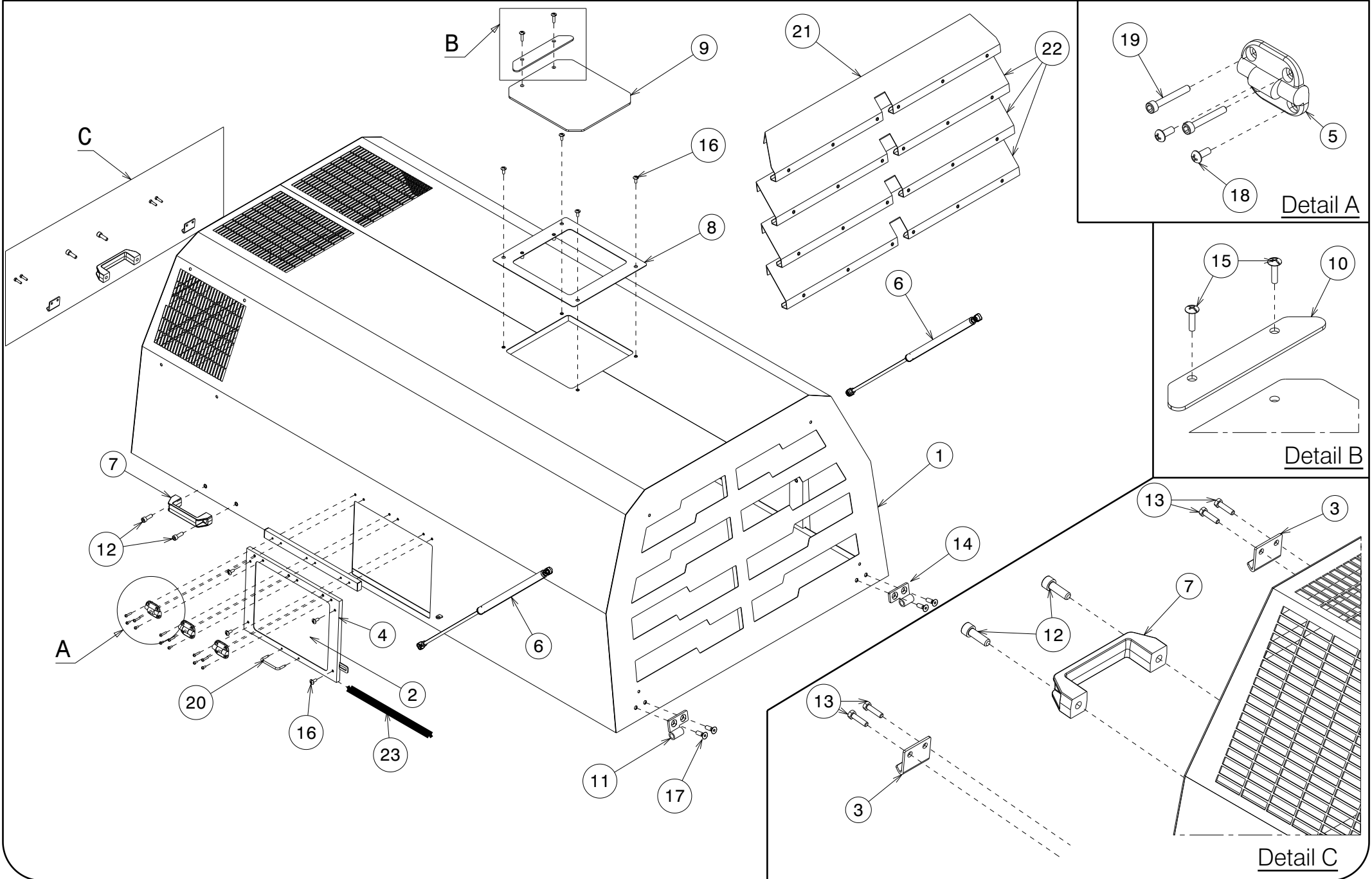



PARTS LIST

Motocompressor – D185T4F

PARTS LEGENDA: Canopy

Tab. 07

REF	NAME	CODE	QUANTITY
1	Canopy	036-178621-S	1
2	Control panel plexiglas door	057-0205-S	1
3	Lock plate	208-001-S	1
4	Control panel door	110-10031-S	1
5	Hinge	007-032-S	3
6	Lifting piston	091-09720-S	2
7	Plastic handle	209-009-S	3
8	Rubber plate closing plate	124-30789402-S	1
9	Rubber plate for hosting hook	177-1915-S	1
10	Rubber fastener plate	208-0042-S	1
11	Fixed left hinge	007-007502-S	1
12	Hex socket head cap screw M8x25 UNI 5931	133-133-S	6
13	Hex head screw M5x20 UNI 5739	132-040-S	4
14	Fixed right hinge	007-007500-S	1
15	Large head screw M6x25	243-012-S	2
16	Large head screw M6x16	243-009-S	8
17	Hexagon socket countersunk head 10x20 UNI 5933	146-151-S	4
18	Large head screw M6x10	243-088-S	6
19	Hex socket head screw M4x30	133-046-S	6
20	Panel door hinge	209-021-S	1
21	Upper soundproofing panel	124-307908-S	1
22	Soundproofing panel	124-307906-S	3
REF	NAME	CODE	LENGTH
23	Gasket rubber reinforced profile	023-209-S	13.50"

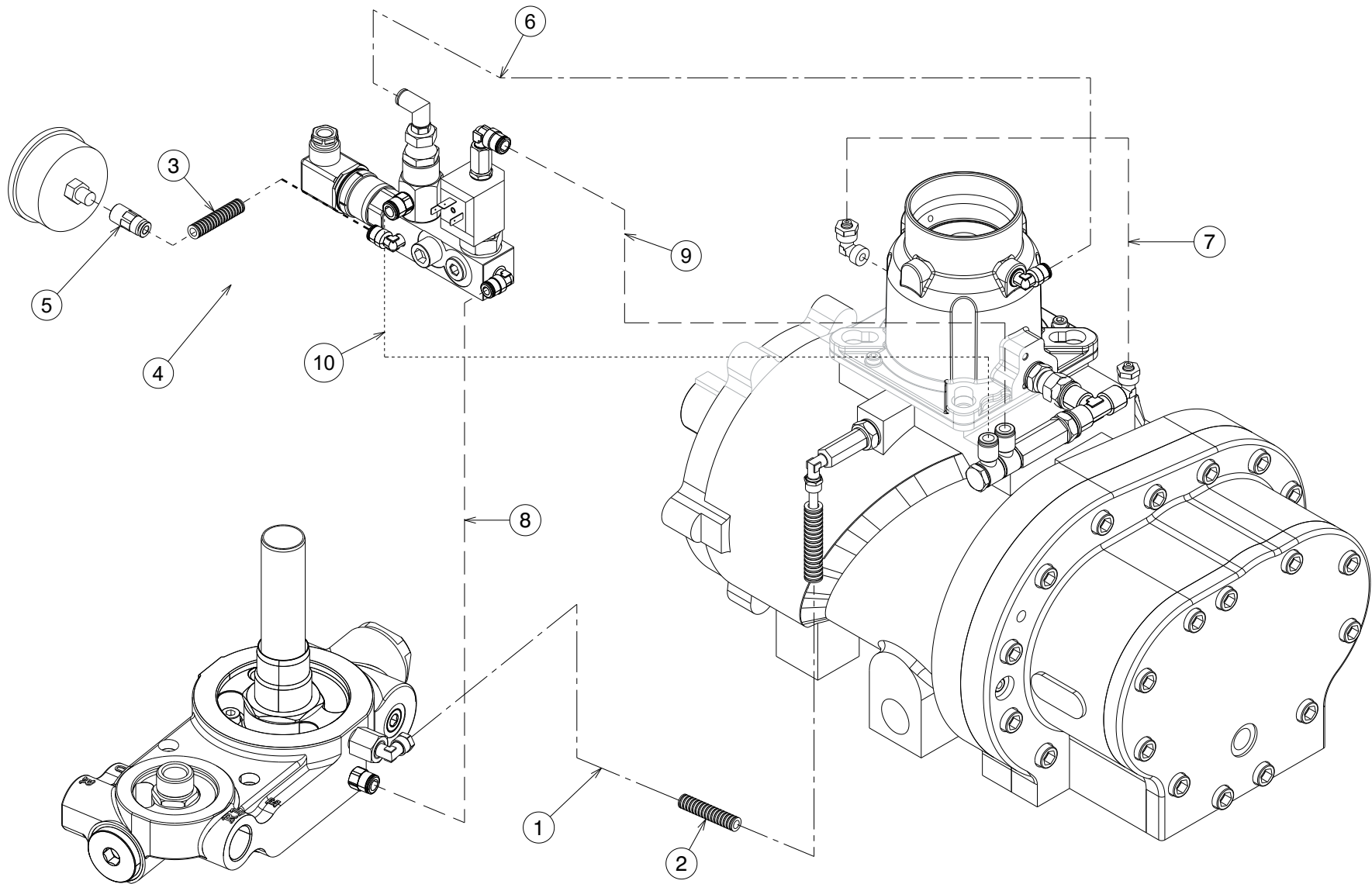



PARTS LIST

Motocompressor – D185T4F

PARTS LEGENDA: Pneumatic system

Tab. 08.1

REF	NAME	CODE	QUANTITY
1	Polyamides pipe d.6	089-060-S	24 in
2	Corrugated pipe d.7.5	089-191-S	21,50 in
3	Rilsan pipe d.6	089-0605-S	78 in
4	Corrugated pipe d.7.5	089-191-S	76 in
5	Straight quick coupling F (1/8") for pipe d.6	148-5765-S	1
6	Rilsan pipe d.8	089-0705-S	25,60 in
7			15 in
8			24 in
9			25 in

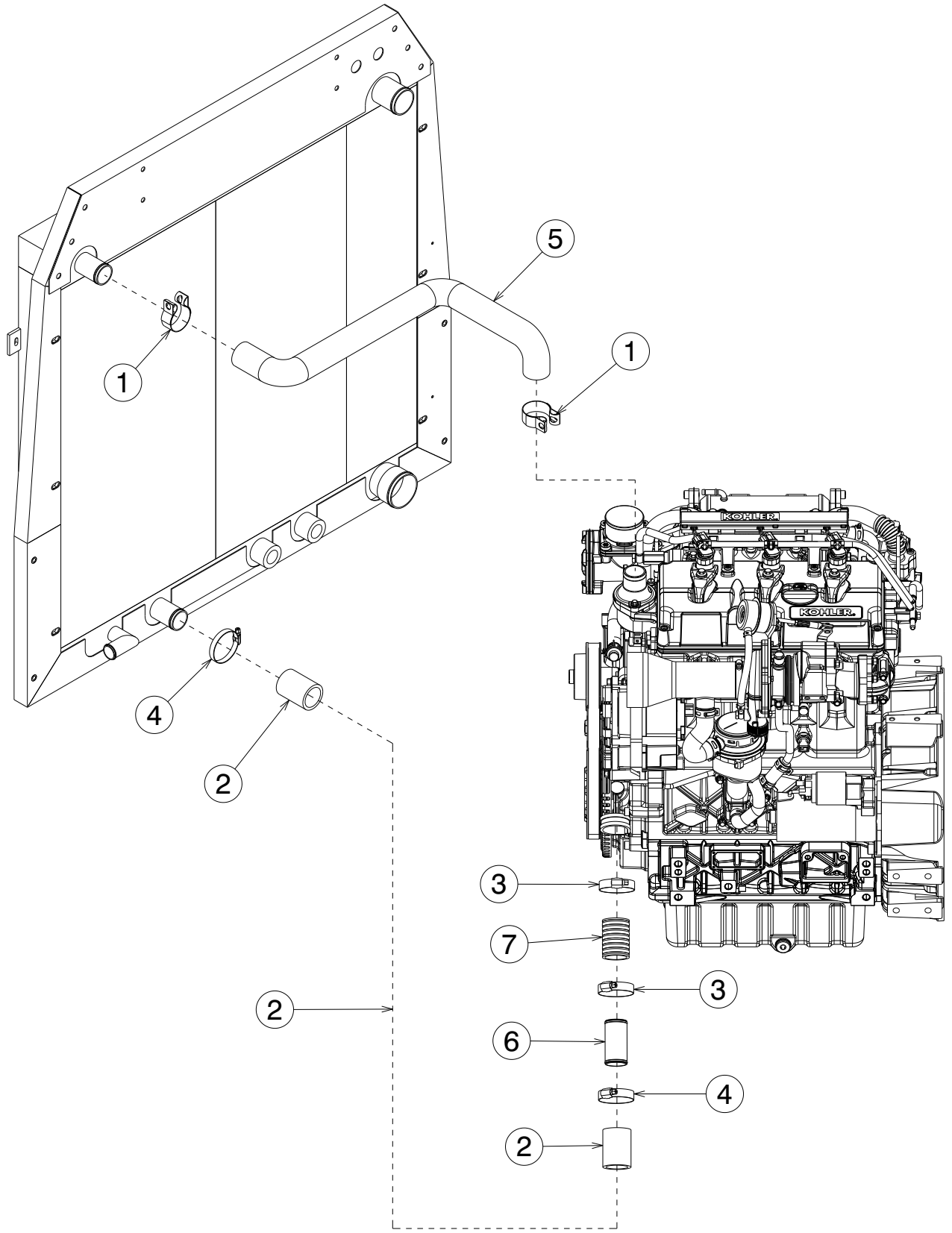



PARTS LIST

Motocompressor – D185T4F

PARTS LEGENDA: Cooling system

Tab. 08.2

REF	NAME	CODE	QUANTITY/ LENGHT
1	Clamp cost.torque 40-43	149-309-S	2
2	Calorflex pipe diam.35x45	089-006-S	21"
3	Clamp 32x50	149-131-S	2
4	Clamp cost.torque 32-54	149-1321-S	2
5	Rubber pipe	090-17500-S	1
6	Reduction d.35 L=70 (From serial No.C39796)	190-613953-S	1
7	Radiator pipe d.35x43 (From serial No.C39796)	089-00560-S	9.80 "

Compensation tank

Tab. 8.2.1

D185T4F - Compensation tank

ELGi

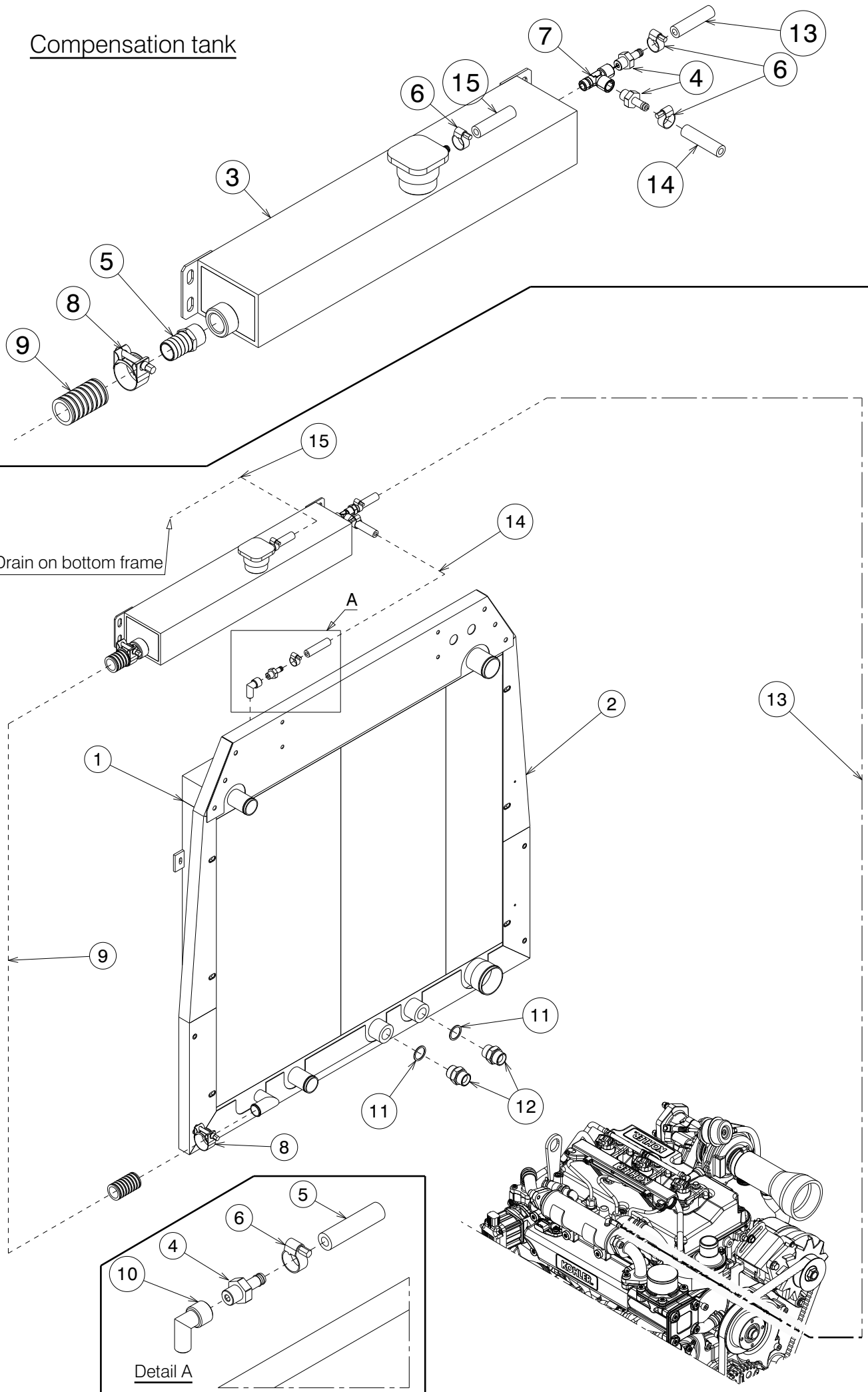

Drain on bottom frame

Detail A



PARTS LIST

Motocompressor – D185T4F

PARTS LEGENDA: Compensation tank

Tab. 08.2.1

REF	NAME	CODE	QUANTITY/ LENGTH
1	Water – oil radiator	011-10430-S	1
2	Radiator support	049-115535-S	1
3	Compensation tank	201-018505-S	1
4	Fitting M (1/4") for pipe d. 8	148-198.2-S	3
5	Joint M (3/4") for pipe d. 25	148-19970-S	1
6	Clamp diam. 8-11	149-005-S	4
7	T Fitting M+F+F 1/4"	148-1942-S	1
8	Clamp SA 34-37	149-308-S	2
9	Calorflex pipe	089-009.5-S	45"
10	Fitting 90' M+F 1/4"	148-143-S	1
11	Copper washer (3/4")	015-015-S	2
12	Double screw 3/4 hole 19,1 Din standard	187-060-S	2
13	Anti-oil pipe for fuel 15x8	089-1203-S	21"
14			31"
15			56"

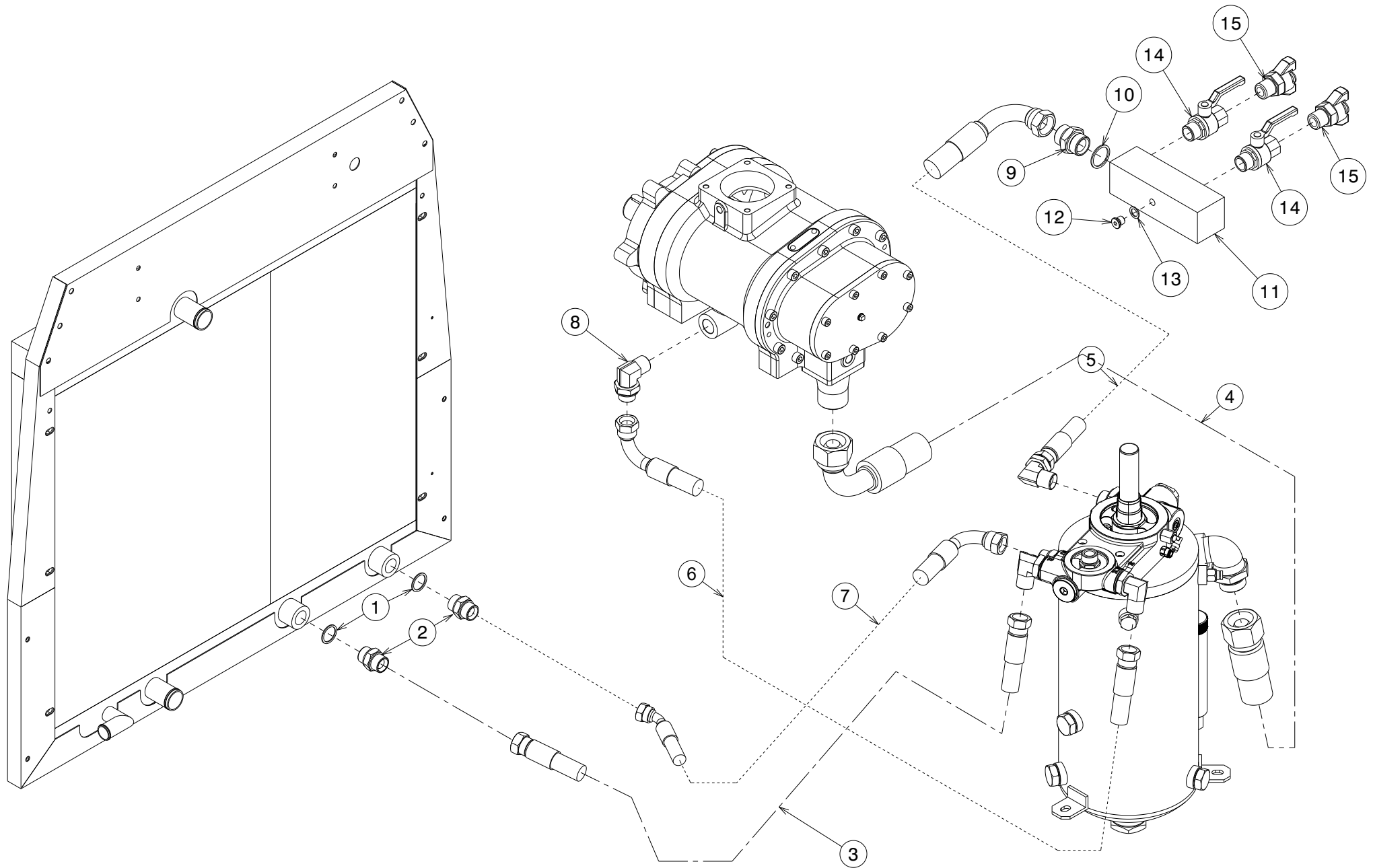



PARTS LIST

Motocompressor – D185T4F

PARTS LEGENDA: Oleopneumatic system

Tab. 08.3

REF	NAME	CODE	QUANTITY
1	Copper washer ($\frac{3}{4}$ ")	015-015-S	2
2	Double screw ($\frac{3}{4}$ ")	187-060-S	2
3	Hose ($\frac{3}{4}$ ")	065-725.2-S	1
4	Hose (1 $\frac{1}{4}$ ")	065-3019.500-S	1
5	Hose (1")	065-852.95-S	1
6	Hose ($\frac{3}{4}$ ")	065-717-S	1
7	Hose ($\frac{3}{4}$ ")	065-779.744-S	1
8	90° fitting M+M ($\frac{3}{4}$ ")	148-2985-S	1
9	Double screw (1")	187-070-S	1
10	Copper washer (1")	015-018-S	1
11	Exit valves clampings sleeve	063-106700-S	1
12	Plug (1/4")	106-086-S	1
13	Copper washer ($\frac{1}{4}$ ")	015-007-S	1
14	Ball valve connection M+F (3/4")	152-030-S	2
15	Bayonet coupling (3/4")	148-650-S	2

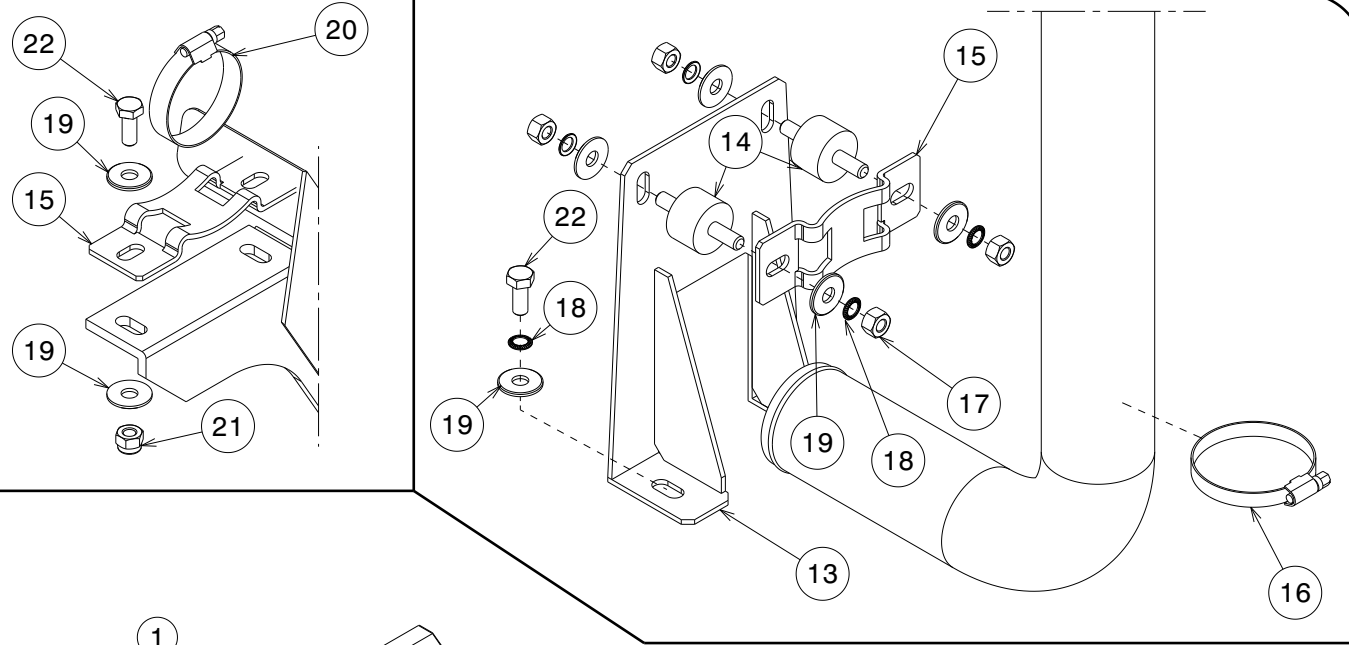
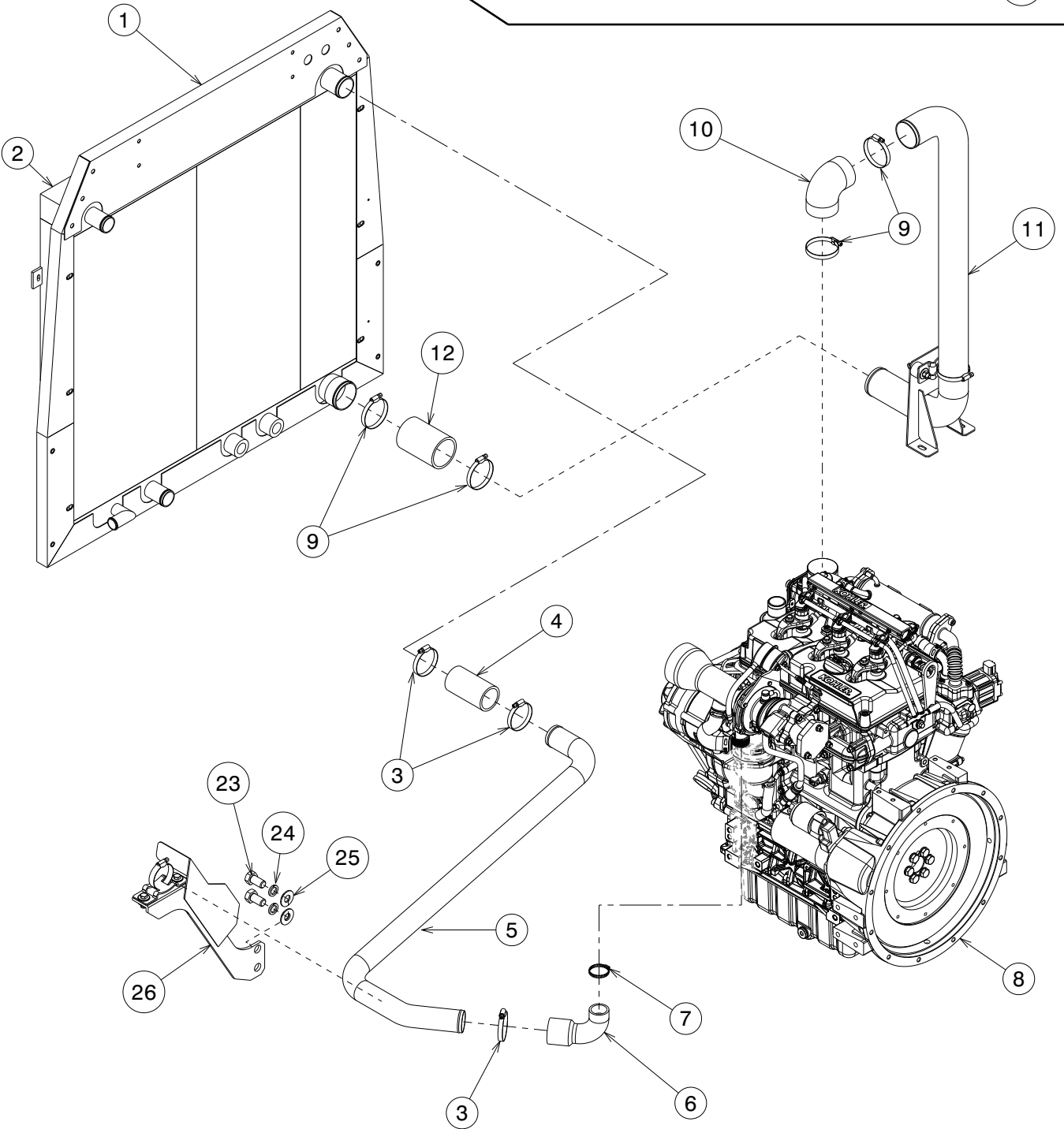



PARTS LIST

Motocompressor – D185T4F

PARTS LEGENDA: Intercooler system

Tab. 08.4

REF	NAME	CODE	QUANTITY
1	Radiator support	049-115535-S	1
2	Water-Air-Oil radiator	011-10430-S	1
3	Clamp diam.45-67	149-1360-S	3
4	Silicone pipe d.45	089-0155-S	4.70 "
5	Intercooler output pipe	064-16802-S	1
6	Curve 90° diam.45x32	111-106720-S	1
7	Clamp diam.32x54	149-1321-S	1
8	Engine	165-42492-S	1
9	Clamp diam. 57-79	149-1420-S	4
10	Curve d.60	111-10605-S	1
11	Intercooler input pipe	064-16800-S	1
12	Silicone pipe d.60	089-0325-S	4.70 "
13	Engine air intake clamping blade	120-3964800-S	1
14	Silent block M8x20	061-013-S	2
15	Normafix Clamp support K1 D.63-80	010-1530-S	2
16	Clamp diam. 50x70	149-140-S	1
17	Hex nut M8 UNI 5587	135-040-S	4
18	Schnorr washer d.8	015-251-S	6
19	Flat washer 8x24x2 UNI6593	015-031-S	8
20	Clamp diam.32x50	149-131-S	1
21	Self locking nut M8 UNI 7473	137-040-S	2
22	Hex head screw . M8x20 UNI 5739	132-101-S	4
23	Hex head screw . M16x30	132-292-S	2
24	Elastic washers d.16	139-080-S	2
25	Plane washer d. 16x35x3	015-048-S	2
26	Intercooler pipe support	120-3964802-S	1

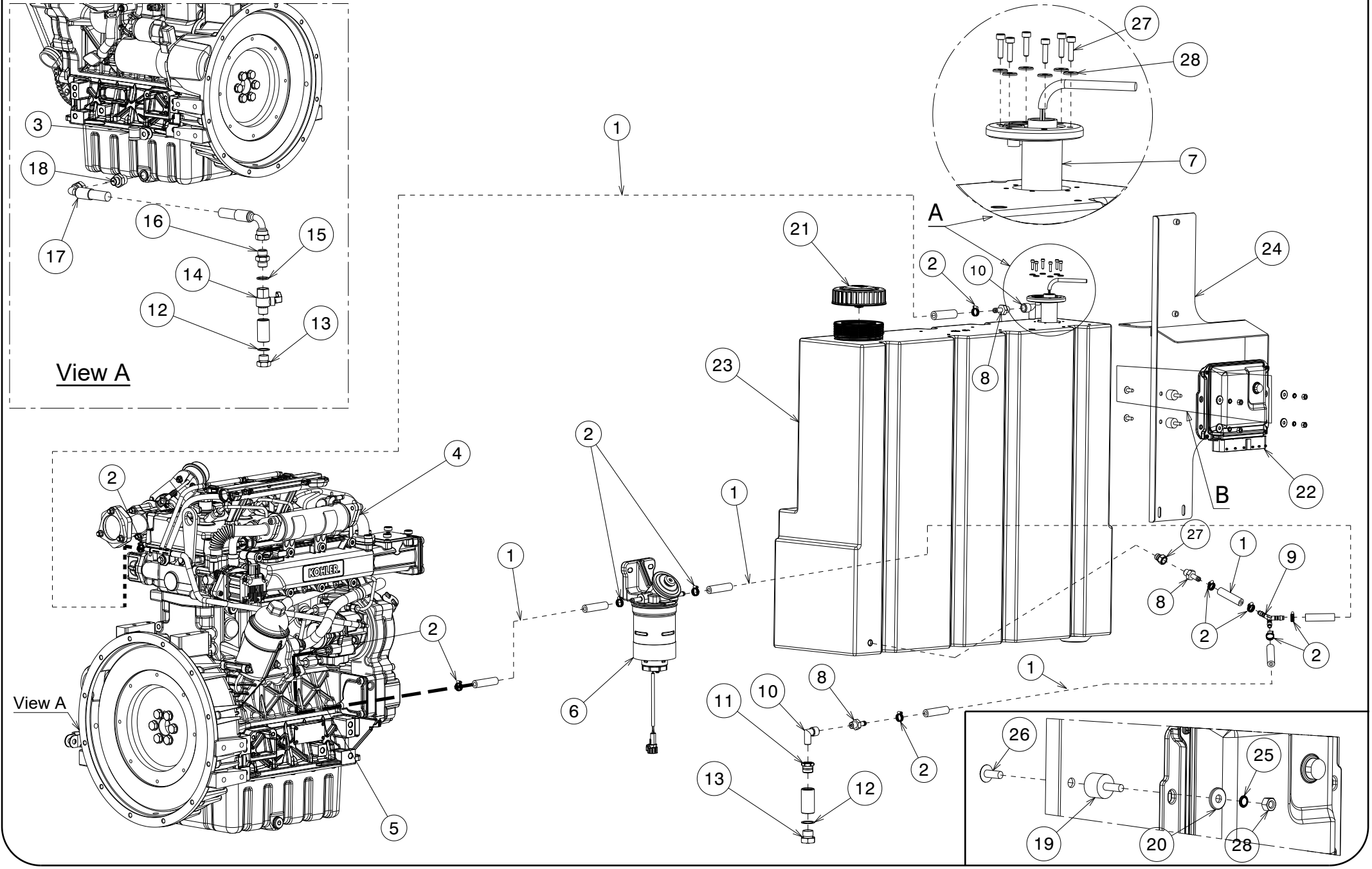



PARTS LIST

Motocompressor – D185T4F

PARTS LEGENDA: Fuel system

Tab. 08.5

REF	NAME	CODE	QUANTITY
1	Anti-oil pipe for fuel 15x8	089-120-S	5
2	Pipe clamp 10x16	149-0092-S	11
3	Clamp	149-236-S	2
4	Engine	165-42492-S	1
5	Engine oil filter	099-1010-S	1
6	Fuel filter	191-0950-S	1
7	Gasoil level control assembly	024-0192-S	1
8	M fitting (1/4") d.8 with OR	148-198.21-S	3
9	Y Fitting	148-1976-S	1
10	90° M+F fitting (1/4")	148-143-S	2
11	Reduction (1/2") M conical to (1/4") F cylindrical	190-001-S	1
12	Copper washer (1/2")	015-012-S	2
13	Iron plug (1/2")	106-125-S	2
14	Ball valve	152-020-S	1
15	Copper washer	015-0121-S	1
16	Double screw (1/2" foro 12.6)	187-045-S	1
17	Pipe 1/2 F90 + F90	065-383.5-S	1
18	Double screw	187-040-S	1
19	Silent block	061-019800-S	4
20	Washer d. 6.6x18x2	015-029-S	12
21	Fuel tank plug	193-0420-S	1
22	Electronic card (it comes with the engine)	---	1
23	Gasoil tank	201-02370-S	1
24	Engine's control support blade	010-31590485-S	1
25	Washer d.6	015-250-S	4
26	Hexagonal head Screw M6x12 UNI 5739	132-061-S	4
27	Straight adapter fitting 1/4"M conical – 1/4"F cil.	148-03600-S	1
28	Hex nut d.6	135-030-S	4

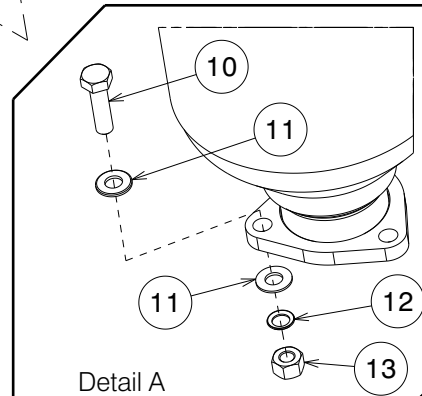
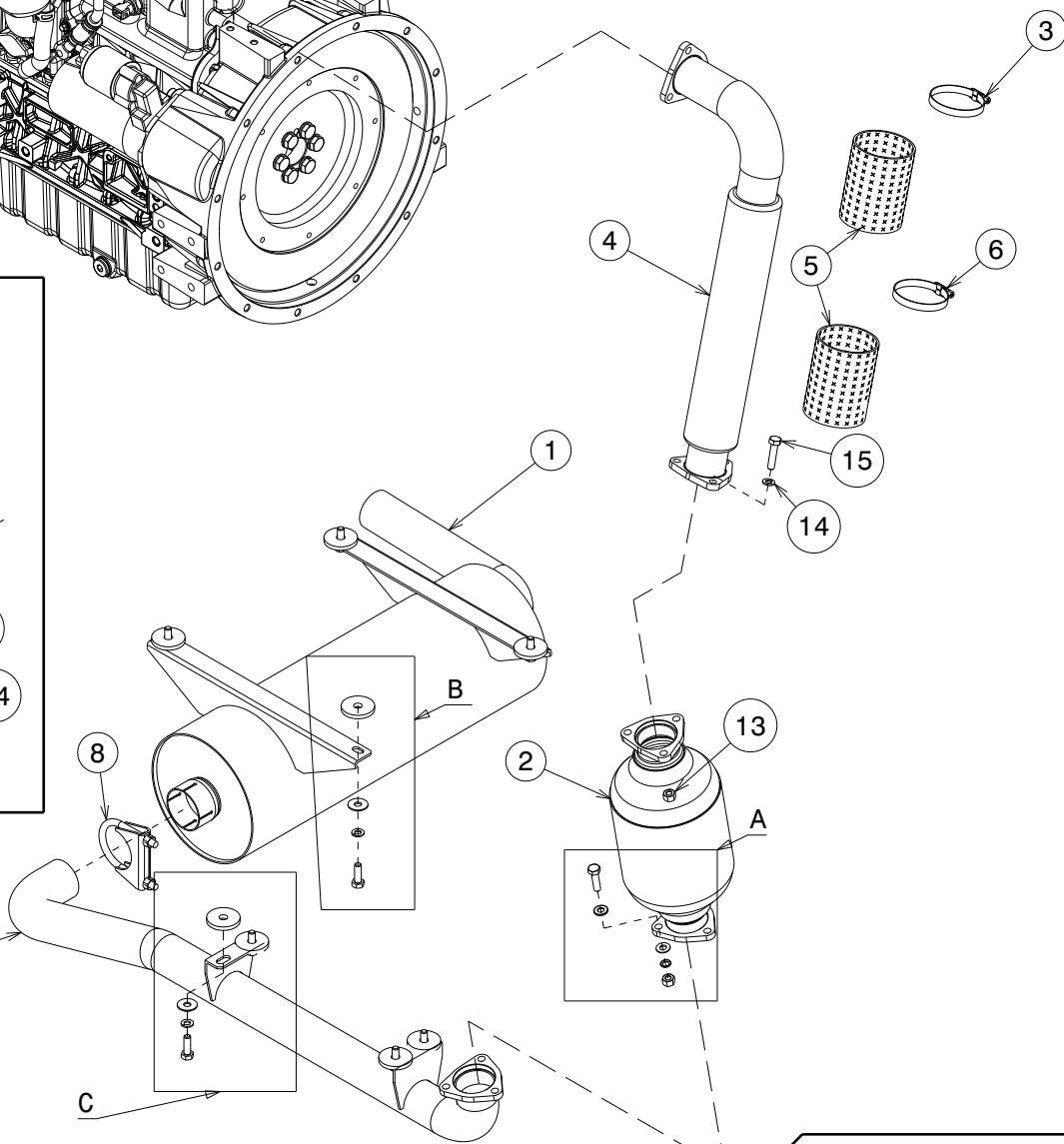
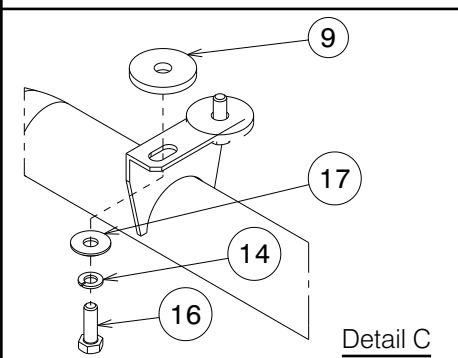
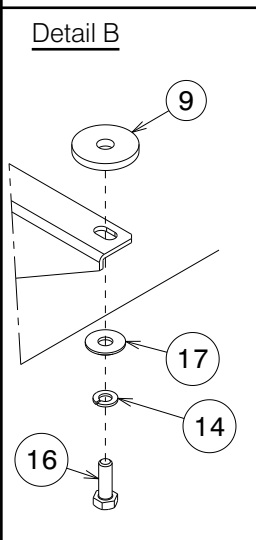
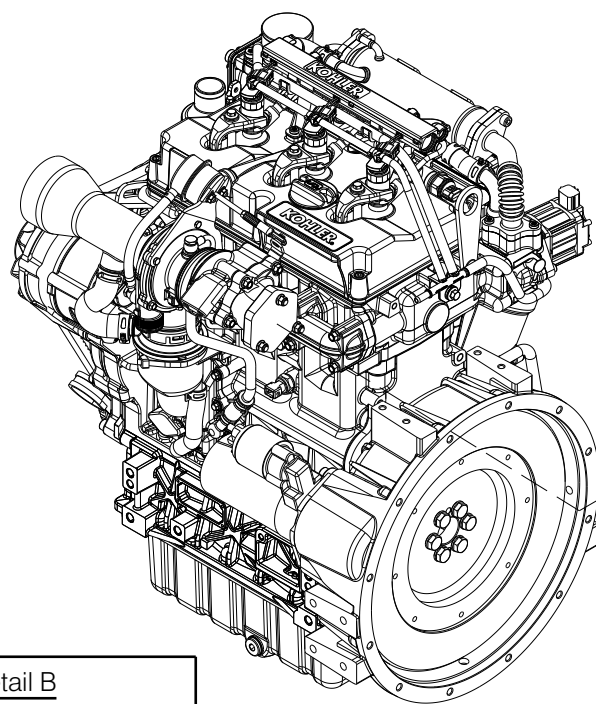



PARTS LIST

Motocompressor – D185T4F

PARTS LEGENDA: Exhaust system

Tav. 08.6

REF	NAME	CODE	QUANTITY
1	Muffler	042-087801-S	1
2	Catalyst	----	1
3	Pipe clamp d.40x60	149-135-S	1
4	Flex pipe	090-101800-S	1
5	Fiber glass braiding d.70	097-0325-G	1
6	Pipe clamp d.50x70	149-140-S	1
7	Exhaust collector pipe	119-07601-S	1
8	Pipes clamp d.54x8	149-070-S	1
9	Seal for muffler d.40 th..5	023-077-S	8
10	Hex head screw M8x30	132-103-S	3
11	Flat washer 8,4x17x1,5 UNI 6592	015-030-S	6
12	Schnorr washer d.8	015-251-S	3
13	Hex nut M8 UNI 5587	135-040-S	6
14	Elastic washer d.8	139-040-S	11
15	Hexagonal head screw M8x30 UNI 5739	132-104-S	3
16	Hex head screw M8x25 UNI 5739	132-102-S	8
17	Flat washer 8x24x2 UNI6593	015-031-S	6



1

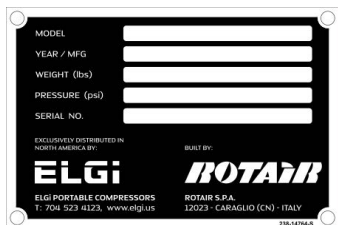

3



4

2



5

7

6

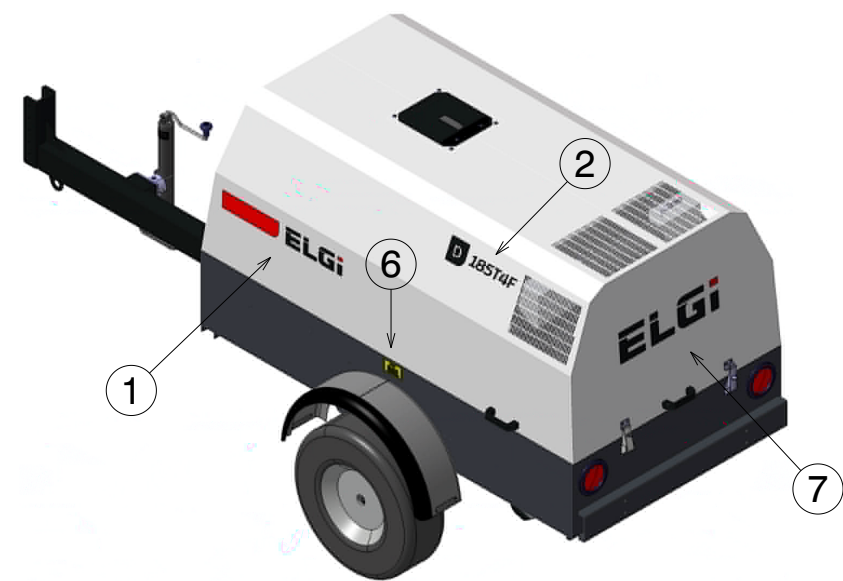



PARTS LIST

Motocompressor – D185T4F

PARTS LEGENDA: Decals

Tab. 09

REF	NAME	CODE	QUANTITY
1	"ELGI Brand" decal	238-3274010-S	2
2	"D 185 T4F" decal	238-3258235-S	2
3	Warnings decal	238-01030-S	1
4	Serial No.plate	238-14764-S	1
5	"ELGI white" decal	238-3274014-S	1
6	"CAUTION DIESEL ONLY" decal	238-097600-S	1
7	"ELGI black" decal	238-3274018-S	1

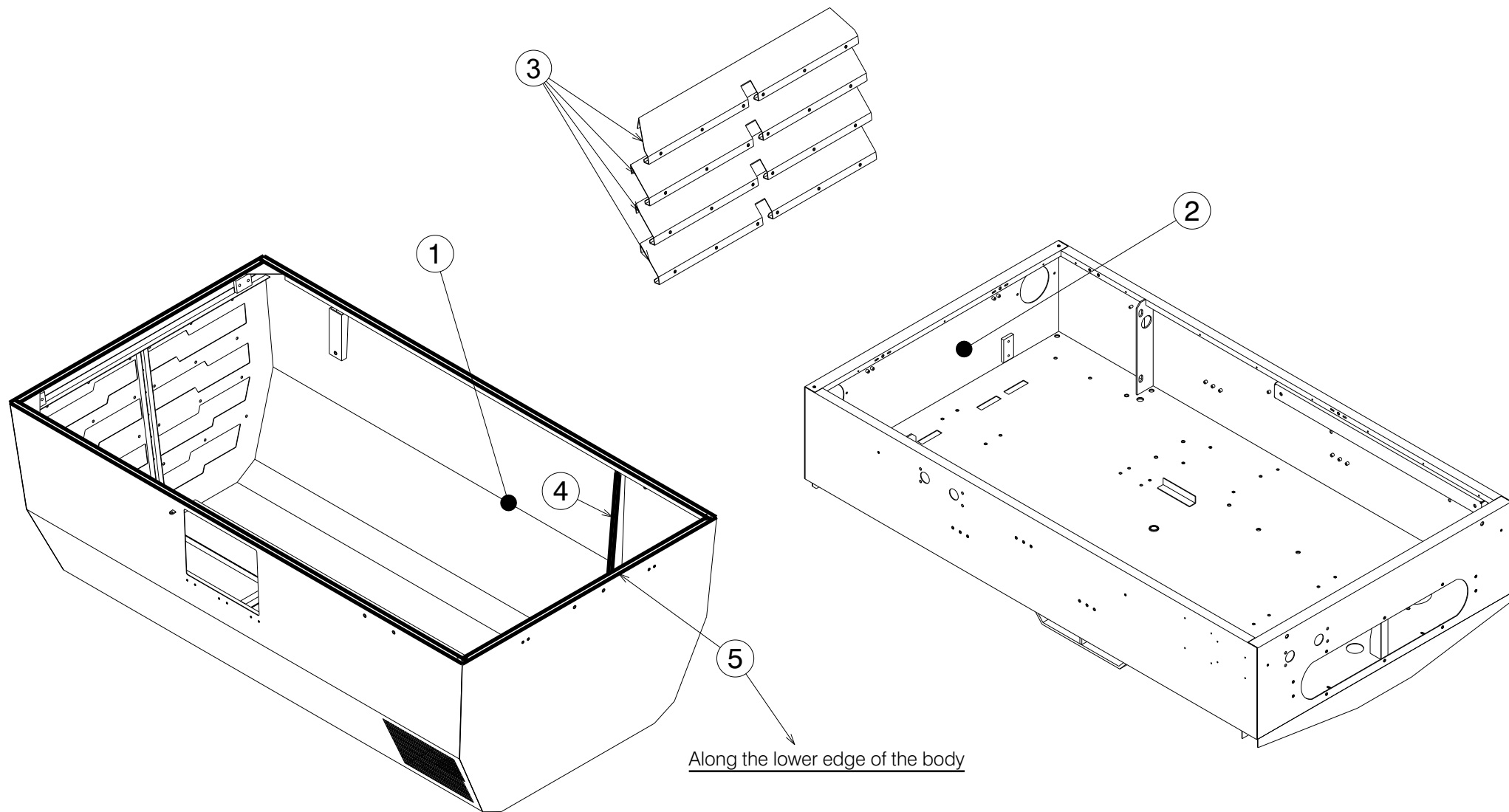



PARTS LIST

Motocompressor – D185T4F

PARTS LEGENDA: Sound-proofing

Tab. 10

REF	NAME	CODE	QUANTITY/ LENGTH
1	Canopy fix part sound-proofing kit	204-313015-S	1
2	Chassis sound-proofing kit	204-34402-S	1
3	Air intake sound-proofing kit	204-34404-S	1
4	Straight SIC profile gasket	023-231-S	45"
5	Adhesive gasket 20X5	023-351-S	110 "

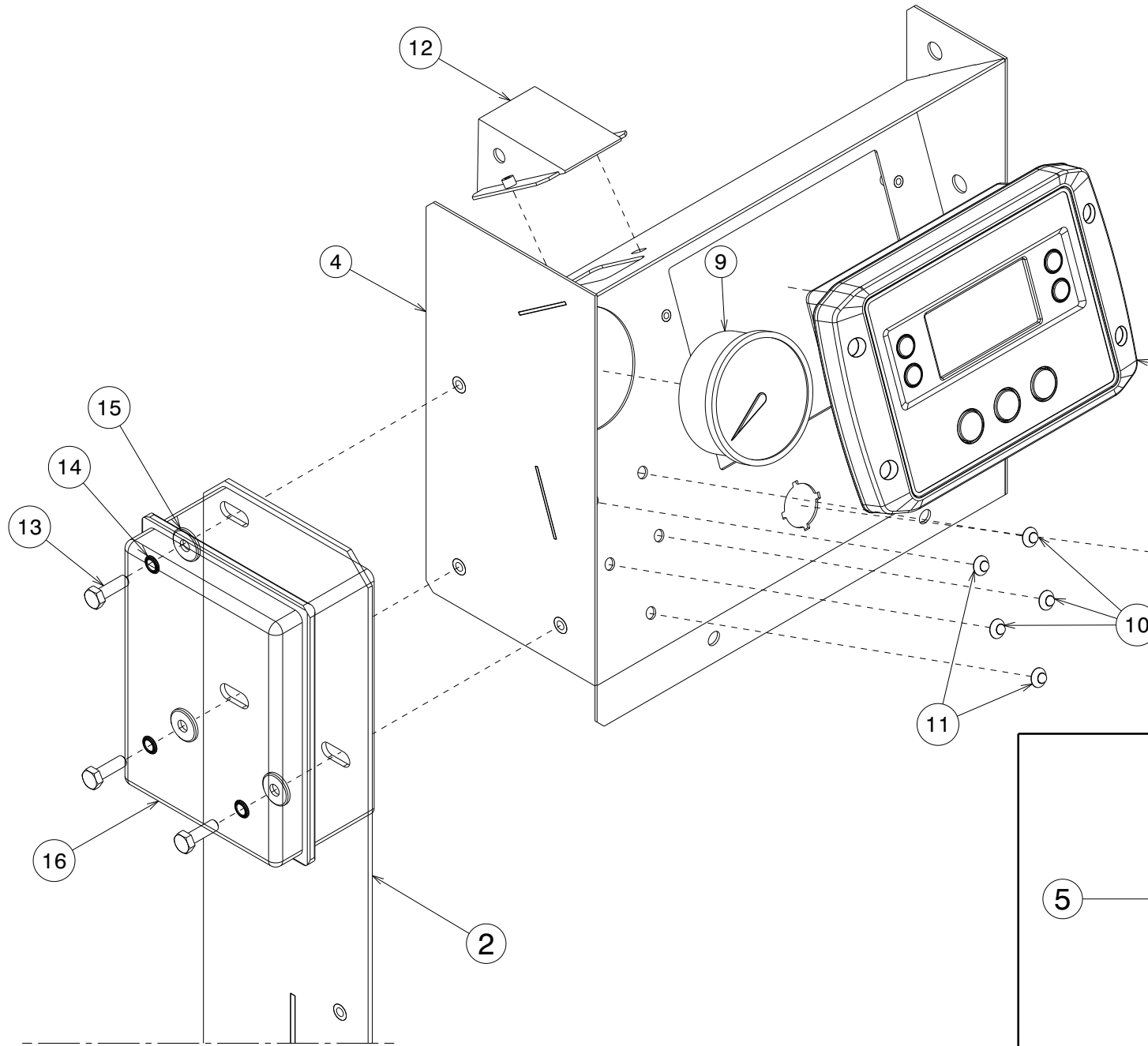

Electrical Harness

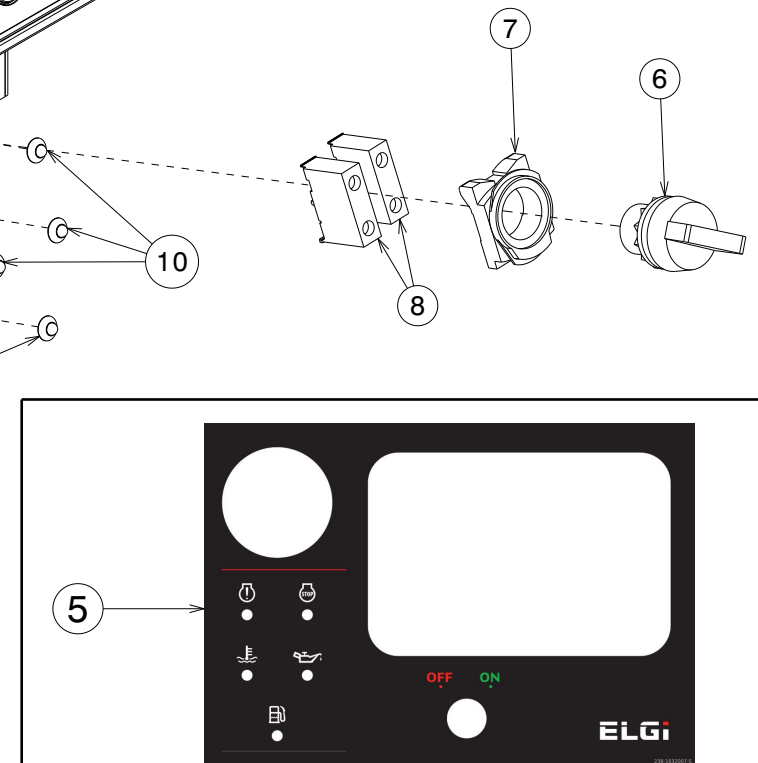
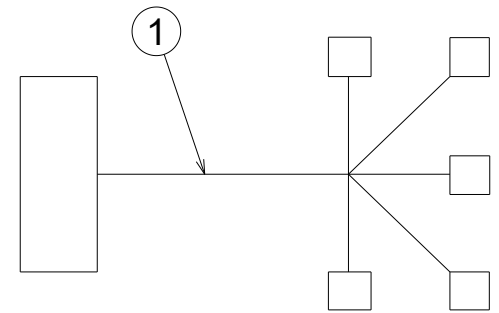



PARTS LIST

Motocompressor – D185T4F

PARTS LEGENDA: Control panel – Electrical harness

Tab. 11

REF	NAME	CODE	QUANTITY
1	Electrical harness	224-470621-S	1
2	Control panel support blade	010-315903-S	1
3	Control board	269-423725-S	1
4	Control panel	040-04270-S	1
5	Control panel sticker	238-1632007-S	1
6	Two-positions selector	249-022-S	1
7	Contact holder	127-376-S	1
8	Contact	127-375-S	2
9	Pressure gauge	206-020-S	1
10	Red warning light	183-011-S	3
11	Yellow warning light	183-041-S	2
12	Temperature sensor protection carter	005-063900-S	1
13	Hex head screw . M6x25	132-065-S	3
14	Schnorr washer d.6	015-250-S	3
15	Washer d. 6.6x12x1,5	015-027-S	3
16	Electrical box	029-200-S	1
Control panel Assembly		024-566100-F	

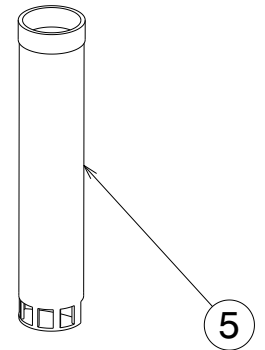
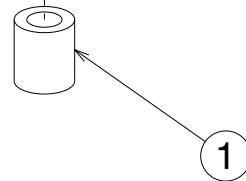
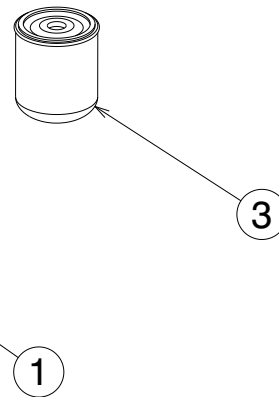
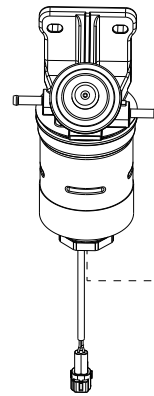
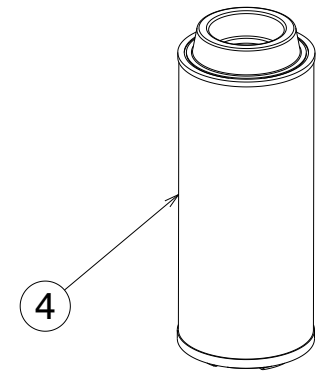
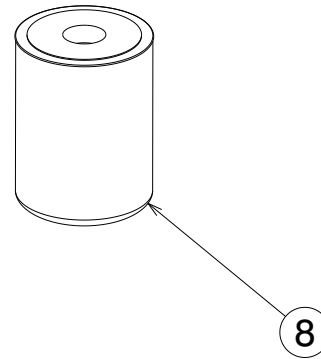
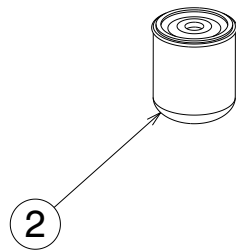
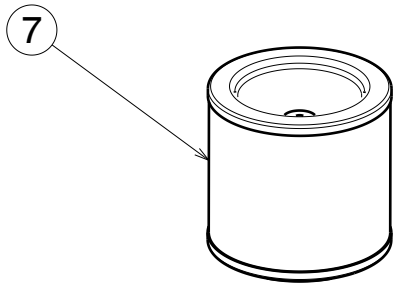
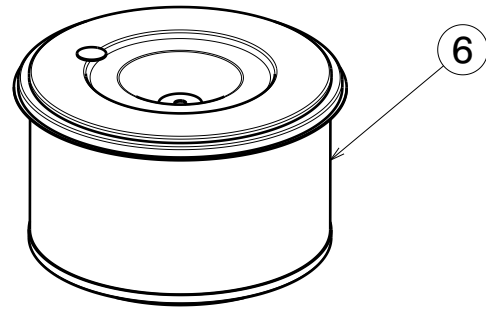



PARTS LIST

Motocompressor – D185T4F

PARTS LEGENDA: Filters Kit

Tab. 12

REF	NAME	CODE	QUANTITY
500 HRS FILTERS KIT		204-0925-S	
1	Engine fuel filter	191-0950-S	1
2	Compressor oil filter	099-008-S	1
3	Engine oil filter	099-1010-S	1
4	1° engine air filter	162-0086-S	1
5	2° engine air filter	162-0087-S	1
6	1° compressor air filter	162-576-S	1
7	2° compressor air filter	162-577-S	1

2000 HRS FILTERS KIT			
1	Engine fuel filter	191-0950-S	4
2	Compressor oil filter	099-008-S	4
3	Engine oil filter	099-1010-S	4
4	1° engine air filter	162-0086-S	4
5	2° engine air filter	162-0087-S	4
6	1° compressor air filter	162-576-S	4
7	2° compressor air filter	162-577-S	4
8	Separator filter	157-171-S	1