

**ELGi**<sup>TM</sup>**USER'S AND MAINTENANCE MANUAL****MOTOR COMPRESSOR****D** *300T4F*



**USER'S AND  
MAINTENANCE MANUAL**

<b>Date:</b>	<b>09/04/2024</b>
<b>Code</b>	<b>MAN D300T4F ENG</b>
<b>Revision</b>	<b>06</b>

**Motor compressor : D300T4F**

Dear customer,

Thanks for having purchased this ELGI motor compressor, which is designed and manufactured in compliance with high standards, in order to ensure high quality performance, as well as easy use and installation.

For any information, you can contact our customer service at the following address:

**ELGI PORTABLE COMPRESSORS**

4610 Entrance Drive St A

Charlotte, NC 28273

704-523-4123

[Portableservice@elgi.com](mailto:Portableservice@elgi.com)

[Portablesales@elgi.com](mailto:Portablesales@elgi.com)



	<b>USER'S AND MAINTENANCE MANUAL</b>	<b>Date:</b>	<b>09/04/2024</b>
		<b>Code</b>	<b>MAN D300T4F ENG</b>
<b>Motor compressor : D300T4F</b>		<b>Revision</b>	<b>06</b>

### FOREWORD

These service instructions have been drafted to facilitate the knowledge of the machinery purchased and its modes of use.

In drafting them, we have intentionally omitted the technical in-depth description of some operations linked to the motor and the axle, since such information is contained in the user's and maintenance of the respective manufacturers.

The service instructions contain indications of utter importance concerning the safe appropriate and cost-effective operation of the machine.

The compliance with said operations helps prevent potentially hazardous situations, additional costs and loss of time, increasing at the same time its life-span.

The service instructions and safety measures reported in this manual must be complied with by the user of the machinery.

Besides the service instructions and the accident prevention prescriptions which apply in the countries and places of installation, all the more general rules of safety at the workplace must be complied with.

It is therefore recommended to carefully read the instructions reported in this manual.

This manual cannot be disclosed, duplicated or copied without the previous authorization by the Manufacturer. Any lack of compliance with the above shall be pursued under the Law, in particular if the illicit action involves advantage for competing companies.





**USER'S AND  
MAINTENANCE MANUAL**

Date:	09/04/2024
Code	MAN D300T4F ENG
Revision	06

**Motor compressor : D300T4F**

**TABLE OF CONTENTS**

**1 General.....7**

1.1 Definitions.....7

1.1.1 Qualified personnel .....7

1.1.2 Hazard.....7

1.1.3 Hazardous area.....7

1.1.4 Exposed person .....7

1.1.5 Operator .....7

1.1.6 Risk .....7

1.1.7 Guard .....7

1.1.8 Protection Equipment.....7

1.1.9 Expected use .....7

1.1.10 Reasonably expectable incorrect use .....7

1.1.11 Component.....7

1.1.12 Control Device.....7

1.1.13 Safety interlock.....8

1.1.14 Manufacturer .....8

1.2 Machinery Identification .....8

1.3 Harmonized technical standards.....9

1.4 General description of the machinery .....10

**2 Technical features of the machinery .....11**

2.1 General technical characteristics .....11

2.2 Technical characteristics of the compressor.....11

2.3 Technical characteristics of the engine .....11

2.4 Technical characteristics of the electric battery .....12

2.5 Service temperatures .....12

**3 Symbols and warnings.....13**

3.1 Hazards .....13

3.2 Forbiddances.....14

3.3 Obligations and notices .....15

3.4 General notices .....15

**4 Use of the machinery .....17**

4.1 Use allowed.....17

4.2 Use not allowed.....17

4.3 Residual risk.....18

**5 Levels and qualifications of the personnel.....19**

**6 Safety provisions .....19**

6.1 Safety provisions concerning transport.....19

6.2 Safety provisions concerning lifting.....19

6.3 Safety provisions relevant to towing (for road-certified compressors only) .....21

6.4 Prescriptions for the installation and parking of the motor compressor .....22

6.5 Safety provisions concerning maintenance .....23

**7 Machinery components.....24**





**USER'S AND  
MAINTENANCE MANUAL**

Date:	09/04/2024
Code	MAN D300T4F ENG
Revision	06

**Motor compressor : D300T4F**

7.1	Chassis and axle .....	24
7.2	Body .....	24
7.3	Engine .....	24
7.4	Compression unit .....	24
7.5	Separator tank .....	25
7.6	Bell and flexible coupling .....	25
7.7	Control panel .....	25
<b>8</b>	<b>Electrical equipment of the machinery .....</b>	<b>26</b>
8.1	Operator's panel tools .....	26
8.3	Fuses .....	29
8.4	Lights (for road-certified version) .....	30
<b>9</b>	<b>Hydraulic and pneumatic systems .....</b>	<b>32</b>
9.1	Hydraulic lubrication system .....	32
9.2	Pneumatic system .....	33
9.2.1	Automatic adjustment of the engine rpm .....	34
<b>10</b>	<b>Provisions for the appropriate utilization of the motor compressor .....</b>	<b>35</b>
10.1	Before starting-up .....	35
10.2	Start-up .....	36
10.3	During the work cycle .....	38
10.4	Stop .....	38
10.5	After stopping the machine .....	38
<b>11</b>	<b>Monitoring and testing of the machine .....</b>	<b>39</b>
11.1	Monitoring and testing of engine speed .....	39
11.1.1	Control system of maximum engine speed .....	39
11.1.2	Control system of minimum engine speed .....	39
11.2	Monitoring and control of the air pressure of the compressor .....	41
11.3	Monitoring and control of air pressure minimum compressor .....	42
<b>12</b>	<b>SAFETY DEVICE (only eu version) .....</b>	<b>43</b>
12.1	Emergency stop buttons .....	43
12.1.1	Operation of the emergency button .....	43
12.2	Verification of the safety valve .....	44
<b>13</b>	<b>Maintenance .....</b>	<b>45</b>
13.1	Routine maintenance .....	45
13.2	Maintenance program .....	46
13.3	Values of tightening screws and bolts .....	48
13.4	Maintenance .....	49
13.4.1	Checking and cleaning air filters air intake .....	49
13.4.2	Control the electrical battery .....	50
13.4.3	Fuse replacement .....	51
13.4.4	Replacement lamps light (for version approved) .....	51
13.4.5	Tyre pressure monitoring .....	52



13.4.6	Clean the radiator cooler.....	53
13.4.7	Percentage dosage of cooling liquid .....	53
13.4.8	Checking and cleaning nozzle oil recovery.....	54
13.4.9	Drainage of the fuel tank.....	54
13.4.10	Replacing diesel pre-filter and filter.....	55
13.4.11	Check break device.....	55
13.4.12	Control of locking wheel bolts .....	56
13.4.13	Oil filter replacement compressor .....	56
13.4.14	Replacement of compressor oil.....	57
13.4.15	Checking the oil mist separator.....	57
13.4.16	Replacement of the oil separator filter .....	57
13.4.17	Engine control and maintenance .....	58
<b>14</b>	<b>Spare parts .....</b>	<b>59</b>
<b>15</b>	<b>Faults and troubleshooting .....</b>	<b>60</b>
<b>16</b>	<b>Disposal, elimination, disposal of the machine .....</b>	<b>62</b>
16.1	Instructions for dismantling .....	62
<b>17</b>	<b>Eliminating the machine .....</b>	<b>62</b>
<b>18</b>	<b>Waste management .....</b>	<b>63</b>
18.1	Special waste .....	63
18.2	Toxic and hazardous waste .....	63
18.3	Temporary storage .....	63
18.4	Features of the containers .....	63
18.5	Registration requirements .....	63





# USER'S AND MAINTENANCE MANUAL

Date:	09/04/2024
Code	MAN D300T4F ENG
Revision	06

**Motor compressor : D300T4F**

## 1 GENERAL

### 1.1 Definitions

The most significant definitions contained in this manual are reported hereinafter

#### 1.1.1 QUALIFIED PERSONNEL

"Qualified personnel" are those personnel who are familiar with the rules for installation, assembly, repair and servicing of the machinery and who are provided with the specified technical qualification, such as e.g.:

Technical training authorizing to operate in compliance with the safety standards as related to the hazards the presence of electric current, pressure circuits, etc. may involve.

Technical background or - in any case - specific training relevant to the user's and maintenance procedures of the machinery in safety conditions.

Training in the basic first-aid activities.

#### 1.1.2 HAZARD

A potential source of injury or damage to health

#### 1.1.3 HAZARDOUS AREA

Any area within and/or in proximity of machinery where the presence of a person constitutes a risk for the health and safety of said person.

#### 1.1.4 EXPOSED PERSON

Any person being fully or partially in a hazardous area

#### 1.1.5 OPERATOR

The person/people charged to install, operate, adjust, clean, repair or move a Machinery or perform its maintenance.

#### 1.1.6 RISK

Combination of the likelihood and severity of an injury or damage to health which may arise in a hazardous situation.

#### 1.1.7 GUARD

Part of the machinery utilized to ensure protection by means of a material barrier.

#### 1.1.8 PROTECTION EQUIPMENT

Device (different from a guard) which reduces the risk, by itself or associated to a guard.

#### 1.1.9 EXPECTED USE

The use of the machinery in compliance with the user's information.

#### 1.1.10 REASONABLY EXPECTABLE INCORRECT USE

The use of the machinery in a different way than the one indicated in the user's instructions, but which may derive from the easily expectable human behaviour.

#### 1.1.11 COMPONENT

A constituent part of the electrical/pneumatic equipment, usually specified by its function, but used in various applications.

#### 1.1.12 CONTROL DEVICE

A device introduced in a control circuit and used to control the operation of the system (e.g. position sensors,



	<b>USER'S AND MAINTENANCE MANUAL</b>	Date:	09/04/2024
		Code	MAN D300T4F ENG
<b>Motor compressor : D300T4F</b>		Revision	06

manual control switches, relays, electro-magnetic control valves).

### 1.1.13 SAFETY INTERLOCK

Mechanical, electrical or other device whose purpose is to prevent the parts of the machinery from operating in specified conditions (generally, until the guard is closed)

### 1.1.14 MANUFACTURER

Physical or legal person who designed and/or develops machinery or partly-completed machinery which is subject of this directive and who is liable for the compliance of the machinery or partly-completed machinery with this directive as related to its marketing with his/her name or brand, or for personal use. In absence of a Manufacturer as defined above, the Manufacturer shall be considered the physical or juridical person who markets or puts into service machinery or partly-completed machinery.

## 1.2 Machinery Identification

The CE identification nameplate is attached on the motor compressor chassis.

Such nameplate reports the Manufacturer's data, the denomination of the machinery, the code and year of manufacturing.

For any requests for spare parts or actions by our technicians, please refer to the data reported in the nameplate; in particular the code number of the machinery must always be mentioned.

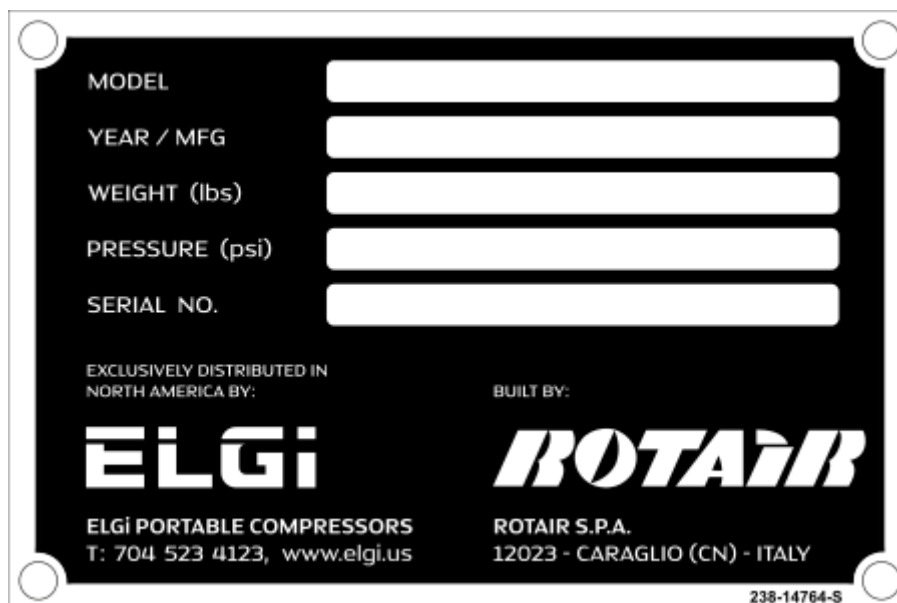

Figure 1.2-1 Nameplate of motor compressor D300T4F



### 1.3 Harmonized technical standards

The machinery has been designed and developed in compliance with the provisions contained in the technical standards reported herein under:

UNI EN ISO 12100	Safety of machinery -General design principles - Risk assessment and risk reduction.
UNI EN ISO 13857	Safety of machinery– Safety distances to prevent from reaching the hazardous areas with the upper or lower limbs.
UNI EN ISO 13850	Safety of machinery - Emergency stop system, functional aspects
CEI EN 62061	Safety of machinery - Functional safety of the programmable electrical and electronic control systems as related to safety
CEI EN 60204-1	Safety of machinery - Electrical equipment of the machineries. Part I: General rules.
UNI EN 983	Safety of machinery. Safety requirements relevant to systems and related components for hydraulic and pneumatic transmission. Pneumatics.
UNI EN 349	Safety of machinery - Minimum openings to prevent the crushing of parts of the human body.
D. LGS. January 27th 2010 no.17	Implementation of Directive 2006/42/CE relevant to machinery, which modifies directive 95/16/CE relevant to elevators.
UNI EN ISO 14121-1	Safety of machinery - Risk assessment. General principles
UNI EN ISO -TR 14121-2	Safety of machinery - Examples



#### **Machine directive 2006/42/CE.**

##### Article 7. Presumption of conformity and harmonized standards

1. The Member States deem that the machinery provided with the "CE" marking and accompanied by the CE declaration of conformity, whose elements are provided for in Annex II, Part 1, Section A, comply with the provisions of this directive.
2. The machinery manufactured in compliance with an authorized standard, whose reference has been published on the Official Journal of the European Union is assumed to be compliant with the essential health and safety requirements covered by such harmonized standard.
3. The Commission published the references of the harmonized standards in the Official Journal of the European Union.
4. The Member States shall take the appropriate measures to allow the social partners influencing - at national level - the development and control process of the harmonized standards.



	<b>USER'S AND MAINTENANCE MANUAL</b>	Date:	09/04/2024
		Code	MAN D300T4F ENG
<b>Motor compressor : D300T4F</b>		Revision	06

#### 1.4 General description of the machinery

The machinery described in this manual is motor compressor D300T4F.

The motor compressor is a piece of machinery with the capacity of generating a given quantity of compressed air in l/m by using a diesel engine as primary energy.

The pneumatic energy finds applications in different fields of use, where "pneumatic" operation tools, accessories and equipment are utilized. For instance: demolition hammers, drilling hammers, vibrators, drilling machines, rammers, coating machines, etc.

Each of these tools/-accessories has its own consumption of compressed air, expressed in liters per minute.

The optimum coupling between the compressor and the tool is achieved when the compressed air consumption does not exceed 85% of the air generated by the compressor (furthermore, it must be taken into consideration that the quantity of compressed air required by the tool shall increase in time, proportionally to the wear of the tool itself).

The correct compressor-tool coupling ratio allows the machinery operating in optimum conditions, as appropriate to ensure long life-span at the highest performance.

An oversized tool - besides creating unfavourable conditions for the appropriate operation of the machinery - shall not develop full performance, since it cannot resort to the required quantity of compressed air.

This machinery has been designed to work at ambient temperature ranging from -10 (14°F) and +40°C (105°F).



## 2 TECHNICAL FEATURES OF THE MACHINERY

The general technical characteristics of the machinery are reported hereinafter.

### 2.1 General technical characteristics

DESCRIPTION	D300T4F
	TECHNICAL VALUES AND DATA
Length (Body)	2100 mm – 82,7 inches
Width	1590 mm – 62,6 inches
Height (with hood closed)	1640 mm – 64,6 inches
Mass of the braked version	1400 kg – 3086 lbs
Mass of the non- braked version	1375 kg – 3031 lbs
Compression system	Screw single-stage
Fuel tank capacity	130 Lt – 24,3 gal
Tire data	185 R14
Pressure value of inflation	2,4 Atm

### 2.2 Technical characteristics of the compressor

DESCRIPTION	D300T4F
	TECHNICAL VALUES AND DATA
Service pressure	7 bars – 102 psi
Minimum pressure	5 bars – 73 psi
Max. pressure	8,5 bars – 123 psi
Rated payload at service pressure	8200 lt/min–290 CFM
Cooling typology	Specific oil for screw compressors (*)
Hydraulic system capacity	17 lt – 4,50 gal

(\*) For the recommended oil see Paragraph 13.4.13

### 2.3 Technical characteristics of the engine

DESCRIPTION	D300T4F
	TECHNICAL VALUES AND DATA
Engine brand	Kohler
Type	KDI2504 – Turbo Common Rail
Number of cylinders	4
Fuel	Diesel
Cooling	By liquid
Power available	55 Kw (74Hp) at 2600 r.p.m.
Max. rotation speed	2600 r.p.m.
Min. rotation speed	1500 r.p.m.
Emissions	Interim Tier 4 Final / Stage III B
Engine oil tank capacity	11,5 lt – 3 gal





## USER'S AND MAINTENANCE MANUAL

Date:	09/04/2024
Code	MAN D300T4F ENG
Revision	06

Motor compressor : D300T4F

### 2.4 Technical characteristics of the electric battery

DESCRIPTION	TECHNICAL VALUES AND DATA
Rated voltage	12 Vcc
Capacity	132 Ah
Discharge current	950 A

### 2.5 Service temperatures

DESCRIPTION	TECHNICAL VALUES AND DATA
Minimum ambient temperature limit	-10°C [14°F]
Maximum ambient temperature limit	+40°C [105°F]
Humidity limits	≤ 50% (à +40°C-105°F)
Altitude	3280 feet above sea level



### 3 SYMBOLS AND WARNINGS

The pictograms and main warning for the operators are reported herein under and indicated by the following denominations and symbols:

#### 3.1 Hazards

**WARNING**

The pictogram calls the attention of specific provisions in order to prevent damage.

**WARNING FOR ELECTRICAL HAZARD**

The pictogram calls the attention of specific provisions in order to prevent damage.

**WARNING FOR CRUSHING HAZARD**

The pictogram calls the attention on a likely hazardous situation with risk of crushing the upper limbs.

**WARNING HAZARD OF ORGANS IN MOTION**

The pictogram calls the attention to the hazard of organs in motion.

**WARNING ON RISK OF SCALDING OR HAZARD DUE TO HIGH-TEMPERATURE ELEMENTS**

The pictogram calls the attention on the hazard of high-temperature elements and risk of scalding.



**WARNING:  
OVERHANG  
ING LOADS**

**OVERHANGING LOAD WARNING**

The pictogram calls the attention to the hazard due to the presence of overhanging loads

**WARNING OF THE PRESENCE OF PRESSURE VESSELS**

The pictogram calls the attention to the presence of pressure vessels.



### 3.2 Forbiddances

**FORBIDDANCE TO REMOVE THE PROTECTION EQUIPMENT AND THE GUARDS**

The pictogram calls the attention on the forbiddance to remove protection equipment such as fixed, movable, interlock guards or to tamper with photocells or photocell barriers.

**FORBIDDANCE TO PERFORM CLEANING OR MAINTENANCE WHEN THE MACHINERY IS IN MOTION**

The pictogram calls the attention on the forbiddance to perform cleaning or maintenance operations with organs in motion.

**FORBIDDANCE TO TRANSIT UNDER OVERHANGING LOADS**

The pictogram calls the attention on the forbiddance to transit under overhanging loads.

**FORBIDDANCE TO START THE MACHINERY WHEN THE HOOD IS OPEN**

### 3.3 Obligations and notices

**NOTICES**

This symbol recommends to consult the manual before undertaking a given action.

**OBLIGATIONS TO USE THE PPE (PERSONAL PROTECTION EQUIPMENT)**

The pictogram calls the attention on the obligation to use the personal protection equipment.

**NOTICES**

This symbol highlights that the description involves significant parts, since they may cause severe mechanical and electrical damage and malfunctions if the relevant standards are not complied with. It is recommended to comply with the information contained in this manual and with the law provisions in force as related to health and safety at the workplace.

**HIGHLIGHTING OF THE HOOKING POINT TO LIFT THE MACHINERY.****OBLIGATION TO USE THE SUPPORT FOOT, THE PARK BRAKE AND WHEEL LOCKING WEDGES.**

### 3.4 General notices

This manual includes the user's and routine maintenance instructions of the machinery. Whenever it is not specified otherwise, the operational and maintenance actions are to be considered as "specialized", i.e. they can only be performed by a technician appointed to the purpose.

Before undertaking any operation on the machinery, carefully read this manual.

ELGI declines any responsibility for any operation performed in conflict with the contents of this document.

Before utilizing the machinery, carefully read this document and comply with the safety law, regulations and standards in force.

This manual and the annexed documents must be considered as an integral part of the machinery they refer to and must always accompany the machinery, even if the latter is transferred to another user. It is therefore appropriate to preserve them for further reference.

This manual and the annexed documents are specific for the machinery they have been drafted for.



**Do NOT utilize this manual and the annexed documents to run operations on similar machinery, of the same brand or typology.**

	<b>USER'S AND MAINTENANCE MANUAL</b>	Date:	09/04/2024
		Code	MAN D300T4F ENG
<b>Motor compressor : D300T4F</b>		Revision	06

ELGI is available to its Customer for any further information. Please report the information (type of machinery, model and code) contained in the machinery identification nameplate. All the specific data not indicated in the text are mentioned in chapter "Technical characteristics of the Machinery" as well as in the technical annexes of this user's and maintenance manual.

This manual thoroughly describes:

- The information relevant to towing, lifting and parking of the machinery;
- The general rules and recommendations useful for routine and extraordinary maintenance;
- The modalities to identify and order the spare parts.

*Remark: the instructions for the appropriate use of the engine are described in the manual drafted by the engine manufacturer.*

This manual must be preserved with care, in its folder, far from sources of humidity, heat and sun rays, so that it can be consulted at any time by both the personnel appointed to the use and by those who need to perform routine and extraordinary maintenance.

This machinery has been exclusively designed and manufactured to deliver compressed air in the conditions stated by the Manufacturer. Every other utilization not mentioned in the "expected uses" shall relieve the manufacturer from any liabilities, which will be at full charge of the user.

"Approved purpose" assumes compliance with the provisions reported hereinafter and related to the appropriate use and maintenance, as well as to the transport of the unit.

All the accident prevention regulations and standards in force need to be complied with as well, besides complying with the general rules in terms of safety and occupational medicine which are governed by the legislation in force.

The manufacturer declines any responsibility in case of changes made on the machinery without its authorization.

Before commissioning, the buyer must ascertain that ANY equipment or machinery, components and protection installations that are not part of the supply of this machinery comply with Machine Directive 2006/42/CE and to the other applicable European Directives (2006/95/CE - 2004/108/CE, etc.).



## 4 USE OF THE MACHINERY

### 4.1 Use allowed

The machinery described in this manual is motor compressor D300T4F.

The machinery is allocated to work outdoor.

The motor compressor is a piece of machinery with the capacity of generating a given quantity of compressed air in l/m by using a diesel engine as primary energy.

The pneumatic energy finds applications in different fields of use, where "pneumatic" operation tools, accessories and equipment are utilized. For instance: demolition hammers, drilling hammers, vibrators, drilling machines, rammers, coating machines, etc.

Each of these tools/-accessories has its own consumption of compressed air, expressed in litres per minute.

The optimum coupling between the compressor and the tool is achieved when the compressed air consumption does not exceed 85% of the air generated by the compressor (furthermore, it must be taken into consideration that the quantity of compressed air required by the tool shall increase in time, proportionally to the wear of the tool itself).

The correct compressor-tool coupling ratio allows the machinery operating in optimum conditions, as appropriate to ensure long life-span at the highest performance.

An oversized tool - besides creating unfavourable conditions for the appropriate operation of the machinery - shall not develop full performance, since it cannot resort to the required quantity of compressed air.

This machinery has been designed to work at ambient temperature ranging from -10(14°F) and +40°C(105°F).



**WARNING:** *It must be highlighted that the compressed air generated by this unit may contain some very fine traces of oil, therefore it is not appropriate to be utilized with those systems that call for fully oil-free air (e.g.: food processing and pharmaceutical industry, transports of flours and powders, cement, etc...).*

### 4.2 Use not allowed

It is not allowed to use the machinery for other processes than those which are mentioned in the section above. ELGI declines any responsibility as related to injuries or accidents due to lack of compliance with the specific provisions for use.

#### 4.3 Residual risk



Avoid standing in front of the compressed air discharges. The direct exposure to the air jet may cause medium severity injuries because of the strength and speed of the compressed air.



The machine must operate outdoor, because of the presence of the engine and of the relevant exhaust gases.



**It is strictly forbidden to operate the machine in indoor environments whose atmosphere is made of vapours or mixtures of corrosive or explosive gases.**

When performing demolition, drilling, sandblasting activities or any other operation that generates dust the tool needs to be connected to the compressor through a pressure-resistant hose of sufficient length to keep the machinery away from the work area, thus preventing the clogging of both the exhaustion filters mounted on the unit and of the radiator for the cooling of the lubrication and cooling liquids. Even in this case, a good operator will locate the machinery leese side versus the work area.

The machinery has been designed and built to work with the hood closed and - consequently - it is forbidden to keep it open when the engine is on, because - besides generation harmful sound emissions - the required internal ventilation would be interrupted, and this is instead indispensable for the appropriate operation of the compressor.

Make sure that the hood is closed, as well as the hinges located on the rear side of the motor compressor.

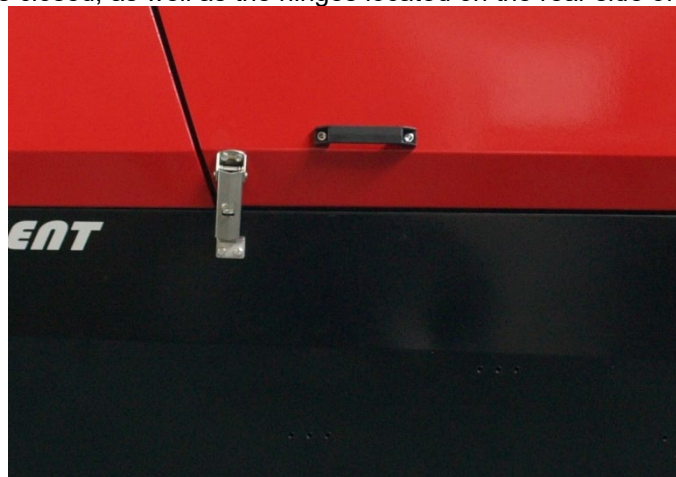

Figure 4.3-1 Engine compartment hood closing hinges

Even selecting the hoses to connect the machinery to the tool, make sure that they are sized as appropriate, taking into account their length, the volume of air which needs to pass through them and the service pressures: if the hoses show a too small diameter or excessive length, the air flow would interrupt, with subsequent loss of load and poor performance of the tool.

The hoses which convey compressed air to from the machinery to the tool, or to any device applied, is to be provided with a tap located at the end which is connected to the tool; the tap shall be held closed during the connection of the hoses to both the machinery and the tool in order to prevent an inappropriate opening of the tap on board the machine from generating strong flickering of the piping, which may cause injuries. Before disconnecting any hose, make sure there is no pressure inside.

## 5 LEVELS AND QUALIFICATIONS OF THE PERSONNEL

The actions on the machinery must be performed by qualified, trained and informed personnel only. "Qualified personnel" means people who - based upon their profession - have acquired experience and instructions as well as knowledge on the relevant standards and provisions on accident prevention and operational conditions. Such personnel, appointed by the machinery safety managers, must be able to perform the required operations as well as to recognize and anticipate the potential hazards.



Entrust the activities to appropriately trained or instructed personnel only; determine unmistakably the competences of the personnel as related to the fine tuning and to the maintenance and repair activities.

Define the responsibility of the operators appointed to run the equipment, also through accurate written provisions and authorize them to reject provisions by third parties if in conflict with the safety regulations and standards.

Make sure that the activities are performed by purposely-appointed personnel only.

The actions on the electrical equipment of the machinery can be performed - in compliance with the electro-technical regulations and standards - only by qualified electricians or by people with an appropriate level of competences in the electro-technical field.

The mechanical and pneumatic maintenance can be performed by the operators of the authorized workshops only.

## 6 SAFETY PROVISIONS

### 6.1 Safety provisions concerning transport

The motor-compressors which are not certified for towing need to be loaded onto another means of transport. The motor compressor shall have to be attached as appropriate to the floor of the means of transport in order to prevent and unbalancing of the load during transport.

The unit is shipped attached to a support appropriate for its handling by means of fork-lift trucks; such wooden platform facilitates the anchorage to the floor of the transport vehicle and prevents the load from sliding. For safe transport, operate as follows:

- 1) Locate the unit with the towing steer opposed to the cockpit of the transport vehicle.
- 2) Locate the towing bar as in Figure 6.1-1.
- 3) Make the ropes pass around the towing bar and tighten them by means of the winches provided with the means of transport.
- 4) Set two wedges (Part A Figure 6.1-1) on each wheel, attaching them to the vehicle floor, in order to prevent the machinery from moving. Utilize wedges of appropriate sizes, both in height and in width.
- 5) Travel at moderate speed.

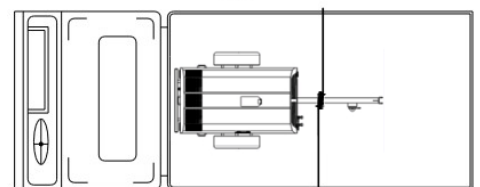
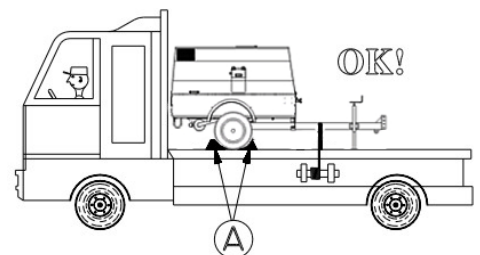

## 6.2 Safety provisions concerning lifting

A purposely-allocated opening, protected by a rubber membrane, is obtained in the upper panel of the hood and allows for easy access to the lifting hook.

List of the operations for the safe lifting of the machine.

- 1) Make sure that the lifting organ (crane, hoist, etc.) is of the appropriate payload to the weight of the unit and that it is maintained as appropriate.
- 2) In case of lifting installed on truck, use the side anti-tilting stabilizes of the means.
- 3) Attach the hook of the lifting means to the hooking point of the compressor (Figure 6.2-1).
- 4) Lift the unit slowly and without sudden pulls. In the side displacements, prevent the load from swaying excessively.

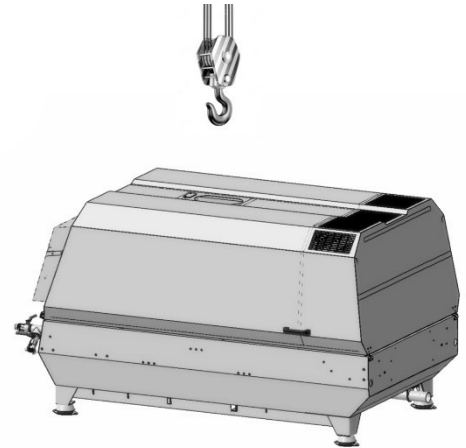

Figure 6.2-1 Lifting system of the machinery



The user must periodically check the efficiency of the lifting equipment and replace it if it results to be no longer appropriate or safe.

No other hooking and lifting systems are allowed except those which are provided with the machine.



This pictogram allows pointing out the hooking system to lift the machine.

- 5) Always check - before handling - that there are no moving parts that may fall. In such case, attach them as appropriate.
- 6) Check the status of ropes and chains before starting the handling operations.
- 7) In any case, always make sure that the machine is solidly fixed to the rope and balanced as appropriate.
- 8) Communicate the start-up of the maneuver as appropriate.
- 9) Never leave the maneuver area with an overhanging load
- 10) Do not stand or transit under the overhanging load.



**WARNING  
OVERHANGING  
LOADS**



### 6.3 Safety provisions relevant to towing (for road-certified compressors only)

This paragraph concerns the machinery enabled to road circulation and therefore provided with regular certification.

For the appropriate towing of the motor compressor, comply with the following prescriptions:

- 1) Make sure that the large towing eyebolt or the sphere connection is compatible with the towing device located on the towing vehicle. Make sure that the vehicle is enabled to tow a weight equal to or greater than the one of the motor compressor you intend to tow.
- 2) Check the pressure of the tires.
- 3) Adjust the height of the eyebolt so that it corresponds to the one of the towing vehicle hook; this can be obtained by acting on the articulate joints of the steer, until the towing bar that supports the eyebolt is as horizontal as possible.
- 4) Solidly lock the articulations by means of the appropriate levers, make sure that there is no clearance between the joint teeth.
- 5) Fit the safety plugs.
- 6) Hook the trailer to the vehicle, connecting also the safety cable.
- 7) Release the park brake.
- 8) Lock the foot, or the support wheel, in the highest possible position, making sure that the wheel cannot rotate on itself, and remove the wheel if required.
- 9) Connect the lighting system by introducing the motor compressor plug into the purposely-allocated power outlet located on the vehicle and make sure that all the lights (position, turn, stop, number plate) are operational.
- 10) If the machinery is provided with inertial brake, the latter disengages automatically when maneuvering at reverse speed.
- 11) Periodically check the brakes and - if required - maintain them.

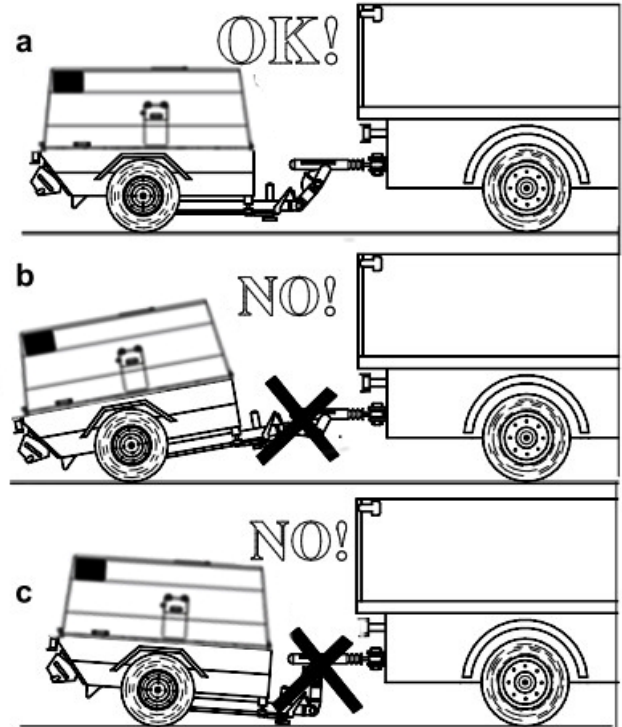

Figure 6.3-1 Instructions for safe towing

For the maintenance of the towing steer, of the axle and for the adjustment of the brakes, refer to the Manufacturer's manual enclosed to this documentation.

**WARNING:** To know the maximum speed for towing on the road, refer to the standards in force in the country where the towing is performed. On site or in a towing area, do not exceed the towing speed of 10 km/h (6 mph).



#### 6.4 Prescriptions for the installation and parking of the motor compressor

Before disconnecting the drawing vehicle, or from the lifting hook, adjust the height of the support foot (Part B Figure 6.4-1) or the pivoting wheel, so that the motor compressor is in horizontal position.

In case the machinery is on incline, locate the wedges (Part A Figure 6.4-1) provided with the machine, in front of or behind the wheels to prevent any displacements, which might also occur during the working stage.

Engage the park brake, if provided (Part C Figure 6.4-1). It is forbidden to operate with the machine hooked to the towing vehicle.

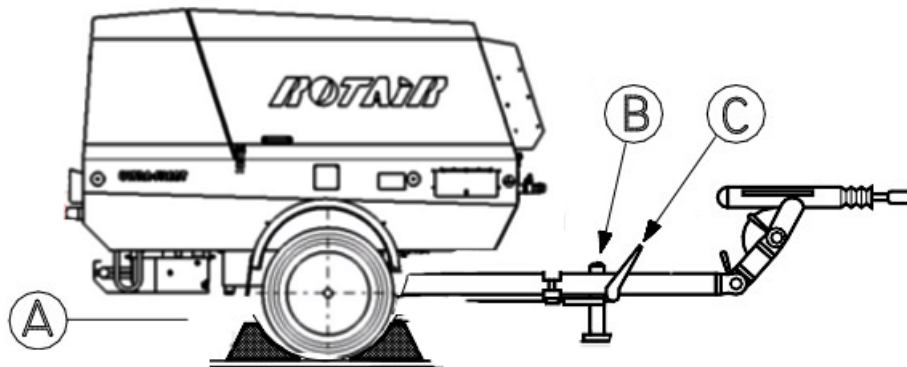

Figure 6.4-1 Instructions for parking and installation of the motor compressor



**When parking, it is mandatory to use the support foot, of the hand brake and of the wheel locking wedges.**

The lever of the manual parking brake is illustrated hereinafter for the braked version only.



Figure6.4-2 Lever of the manual park brake with release red push-button

## 6.5 Safety provisions concerning maintenance

In order to perform the maintenance operations in safety conditions, the following provisions need to be complied with:

- The control and maintenance operations need to be performed by specialized qualified personnel aware of the indications shown in this manual. "Specialized qualified personnel" means people with the appropriate educational background and whose level of skills is appropriate to the kind of intervention and who have acquired experience and instructions on accident prevention and on the procedures required to perform maintenance operations;
- all the maintenance activities need to be performed after a safe stop of the machine and interrupting power supply to the engine;
- if the machinery is stopped during the maintenance and repair operations, it must be protected against accidental restart;
- in case of replacement of parts, the spare parts must be ordered at ELGI 's customer service and must correspond to the technical standards defined by ELGI;
- the electrical equipment of the machinery must be periodically inspected. Any component's' faults must be immediately pointed out and replaced after careful assessment of their effectiveness and efficiency;
- keep the greatest possible cleanness during the maintenance operations, avoiding using flammable solvents;
- before restarting the machinery after maintenance or overhaul, make sure that all the guards and safety devices are restored and operational.
- never use water to extinguish the flames in case of fire (Figure 6.5-1).



Figure 6.5-1

**After performing the maintenance operations, it is mandatory to restore the protections and - in particular -on the area of the cooling fan moving organs**



## 7 MACHINERY COMPONENTS

This unit is a single-phase, silenced oil injection screw mobile motor compressor.

The engine is internal-combustion, fuelled by gas oil, and is connected to the compressor by a flexible coupling.

### 7.1 Chassis and axle

The chassis is made from contoured and electrowelded metal sheet and is of load-bearing type. This chassis undergoes two painting treatments which guarantee corrosion resistance and rust-proofing.

In the chassis there is the control panel which is protected by a transparent polycarbonate lid and which allows the compressed air pressure and the compressor oil temperature values to be read and allows a visual control of the warning lights each of which will indicate any anomalies of the machine element to which it is connected.

A sprung axle of large dimensions supports the machine weight. It also has a drawbar which can be fitted with hook and eyelet or sphere type. It consists of articulated, elements which permit correct attachment to the various pulling means.

To tow the motor-driven compressor on the road it must be of homologated version fitted for towing complete with lighting system, headlights and licence plate, braking system and relative authorization from the "Motorization" department.

The braking system includes the parking brake and the inertia braking system. Both act on the wheel-carrier drums of the axle.

### 7.2 Body

The body is built entirely out of galvanized sheet iron. It can easily be turned over thanks to a gas hoist and thus allows convenient access to the main machine elements. The whole machine is entirely lined with sound absorbent and fire-retardant material.

Special holes have been created in the elements forming the body, complete with baffles, which allow the cool air necessary for engine and compressor cooling to be sucked in from one side and the heated air to be expelled from the other side. These baffles have been carefully designed in terms of size and shape so as to allow the most efficient internal ventilation of the machine: it is advisable, therefore, to make sure that these openings are kept free and undamaged.

All the parts of the body have been treated with a special painting process which guarantees excellent finishing quality together with maximum impact and rust resistance.

### 7.3 Engine

The unit is equipped with a Diesel engine whose features are described in Section 2.

As related to the user's and maintenance instructions, refer to the manual provided by the Manufacturer and enclosed to the documentation relevant to this machinery.

### 7.4 Compression unit

It is completely manufactured in the factory and consists of a central body (cylinder) inside which are fitted two screw rotors with asymmetric section, a male one with 5 lobes and female one with 6 lobes.

The cylinder is closed at the ends by two head sections which contain the bearings which bear the radial and axial loads created by the air compression. A series of channels, inside the cylinder and heads, undertake to deliver the oil to the various components. The distribution of the lubricant, serves to lubricate the bearings and to maintain a coating of oil between the rotors and the bearings themselves as well as the internal cylinder walls, thereby promoting compression resistance. Another important function of the oil injected between the rotors is that of absorbing the heat generated by the air compression.

The compressed air supplied by this compressor is free of any pulsations and compression comes about axially.





## USER'S AND MAINTENANCE MANUAL

Date:	09/04/2024
Code	MAN D300T4F ENG
Revision	06

**Motor compressor : D300T4F**

A "regulator" unit is mounted on the compression unit, the purpose of which is to regulate the quantity of air taken in according to the amount of air consumed. A double-stage filter mounted on the top of this unit guarantees maximum purity of the suctioned air.

### 7.5 Separator tank

Consists of a pressurized container, and due to its construction features it is exempt from the annual I.S.P.E.L. inspection and is supplied with a conformity certificate issued by the manufacturer. The identification and inspection details are impressed on a plate which is welded to the machine.

The lid features the following elements: safety valve for overpressure, a thermal switch which intervenes if the temperature inside the tank exceeds 100°C and valves which regulate the maximum and minimum pressure of the machine.

### 7.6 Bell and flexible coupling

The engine and the compressor are interconnected by a bell which guarantees concentricity between the engine flywheel and the compressor shaft.

A large-size block joint with rubber pieces interspaced transmits power in a smooth and silent way without splitting.

The engine-compressor thus assembled is clamped to the frame with four flexible supports (silent-blocks) which completely absorb the vibrations it generates. A fan is splined to the engine shaft on the opposite side to the flywheel which generates large air displacement which cools the machine fluids and elements.

### 7.7 Control panel

The control panel layout, on the RH, was specifically designed so as to have all the controls within reach of a single person.

All the necessary instruments to control the unit are located on the control panel.



**8 ELECTRICAL EQUIPMENT OF THE MACHINERY**

WARNING: any action on the electrical system must be performed by qualified personnel.

**8.1 Operator's panel tools**

- 1) Pressure gauge;
- 2) Hour counter;
- 3) START button;
- 4) ON/OFF switch.

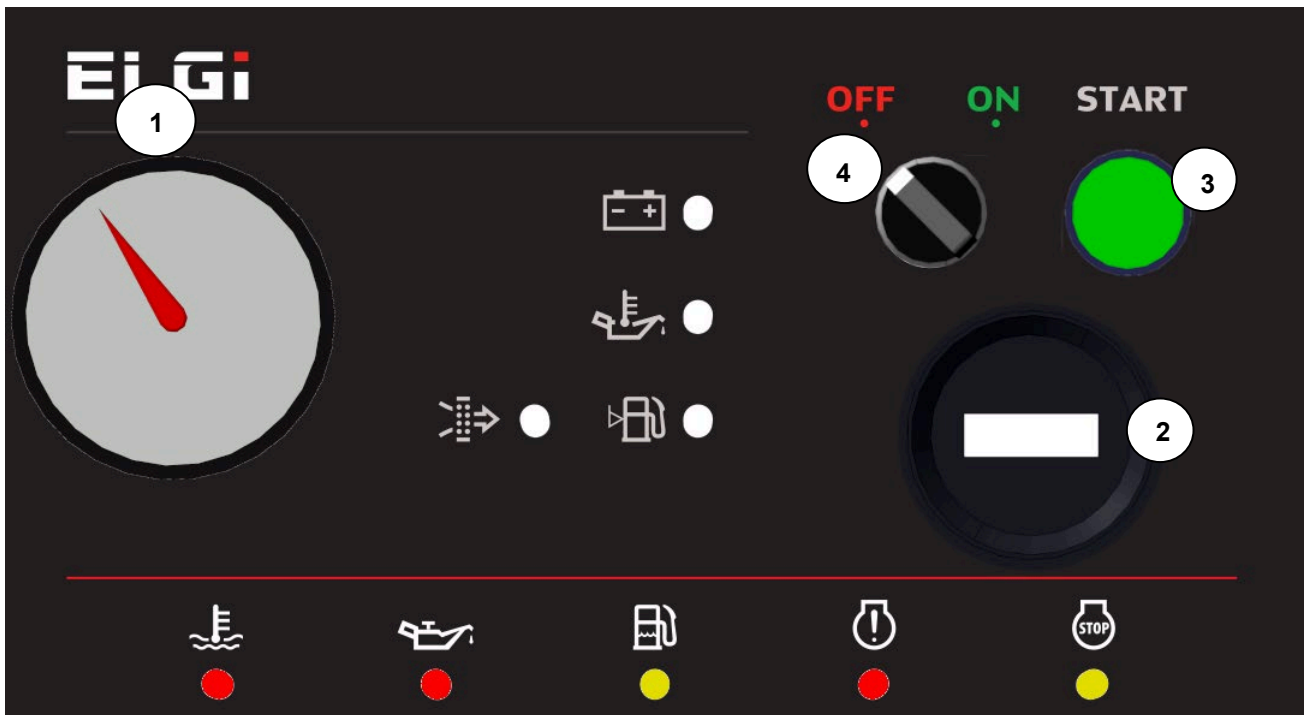

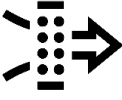









Figure 8.1-1 Instrument panel and control devices

PILOT LAMP	DEFINITION	FUNCTION	OPERATION TO BE PERFORMED
	FUEL	The fuel lamp highlights the minimum level of fuel in the Diesel tank of the motor compressor	Top up the fuel (Diesel only)
	AIR FILTER CLOGGED	This pilot lamp highlights that the air filter is clogged.	Clean the filter or replace it
	HIGH TEMPERATURE LAMP	This pilot lamp highlights that the radiator cooling liquid have reached an excessive temperature	Immediately switch off the machinery and verify the following cases 1) check the liquid level in the radiator and clean it; 2) the cooling liquid pump does not operate as appropriate (contact ELGI customer service); 3) the liquid valve does not close or open at the right moment (replace); 4) if the cooling liquid is leaking, contact ELGI customer service; 5) the radiator is obstructed (contact ELGI assistance).
	HIGH TEMPERATURE COMPRESSOR OIL	This pilot lamp highlights that the compressor oil have reached an excessive temperature	Immediately the compressor automatically switch off, then verify the following cases 1) check the oil level; 2) check the the radiator; if the radiator is obstructed clean it; (contact ELGI assistance).
	ENGINE OIL PRESSURE LAMP	This pilot lamp highlights the insufficient pressure of the engine oil. The lamp is off when the engine oil is in pressure Pilot lamp lit: engine oil not in pressure.	The oil pilot lamp highlights the insufficient pressure of the oil. Such insufficient pressure may be caused by: 1) engine oil level check; 2) breakage of the delivery pump; 3) oil not reaching the delivery pump
	ALTERNATOR CHARGE LAMP	This pilot lamp monitors the efficiency of the alternator. The pilot lamp must be off when the engine is running.	Should it light up during the normal operation, check the efficiency of both the battery and the alternator.
	STOP ENGINE	This warning light lit when the engine control unit detects a serious malfunction.	<b>STOP</b> the engine immediately and contact ELGI assistance service.
	WATER IN THE FUEL	The fuel warning light lit when the engine sensor detects the presence of water in the fuel system.	<b>STOP</b> the engine immediately, empty the fuel tank and fuel system. Replace with new fuel.
	CHECK ENGINE	This light signals lit when the engine sensor detects a problem (a broken sensor, etc.)	The problem detected by the engine is of medium entity and allows the compressor to continue to be used; to identify the status of the problem, check the electronic control board.

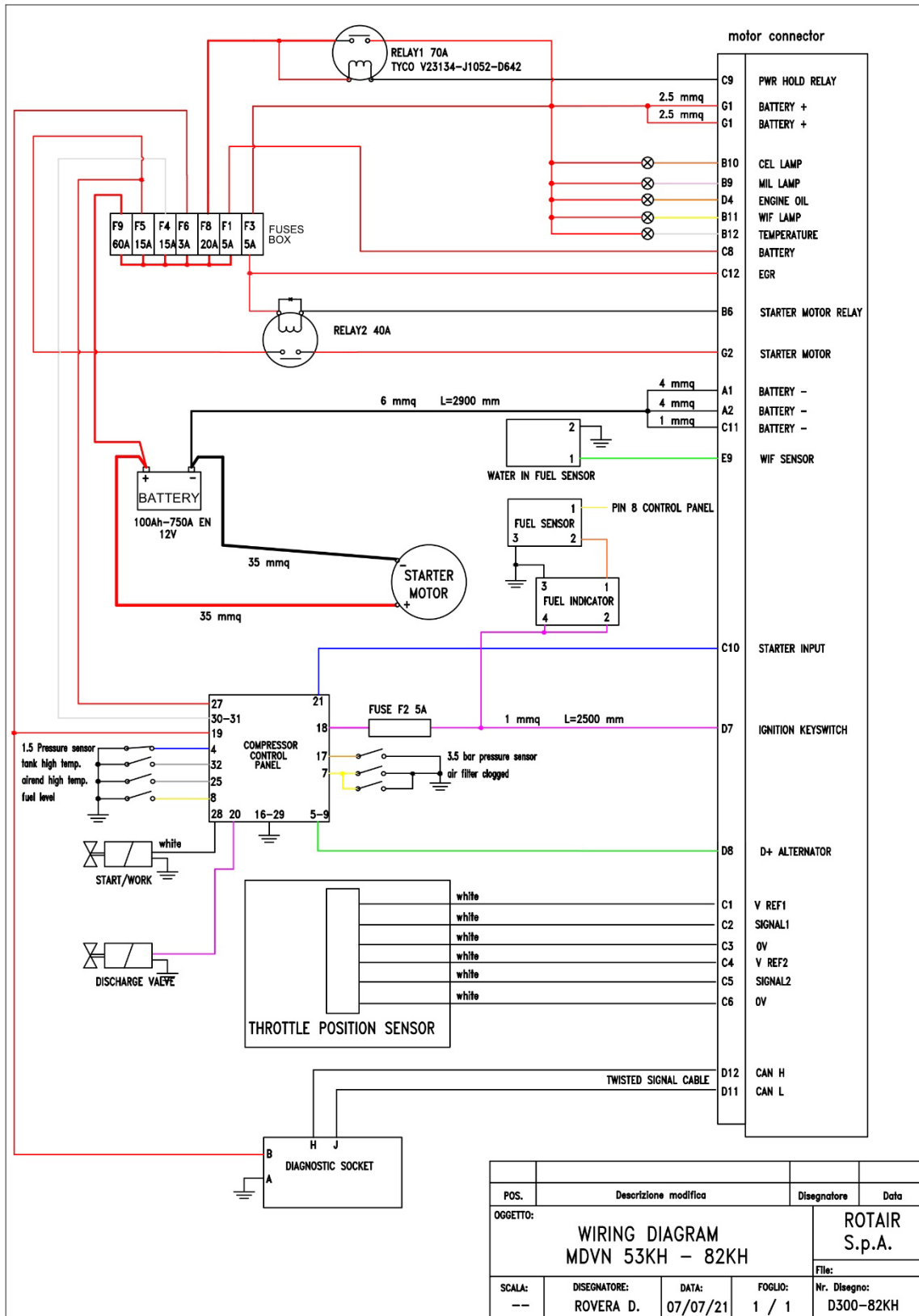

Figure 8.2-2 Diagram machine's electrical system D300T4F



### 8.3 Fuses

The fuse is an electrical device which can protect a circuit or a device from over current.

The fuse consists of a cartridge provided by a thin lead wire through which the rated current of the circuit/element transits; this wire is the actual fuse, with a precise Amp load. In case of overcurrent, the filament melts and causes the circuit to open.

Fuse holder	Fuse	Description	Ampere
		Secondary fuse: device to protect against overcurrent which might damage the fuel solenoid	16 A
		Operator Panel Fuse: protection device against overcurrent that may damage the operation panel	40 A
		Protection device against overcurrent that could damage the engine glow plugs during warm.	40 A



**WARNING:** When replacing the fuses, we recommend always utilizing the sale type as indicated in this table and to follow the procedure reported in section 13.4.3 of the manual.

#### 8.4 Lights (for road-certified version)



In the road-certified machinery, the electrical system is completed by the light wiring (Figure 8.4-3). The table here in under reports the connections of the wires within the 7-pole outlet and their connection to the rear lighting equipment. This system is directly connected to the towing machine through an extension supplied with the motor compressor.

##### Rear lights:

- 1) Turn light
- 2) Position and stop light (stop detected by light intensity)

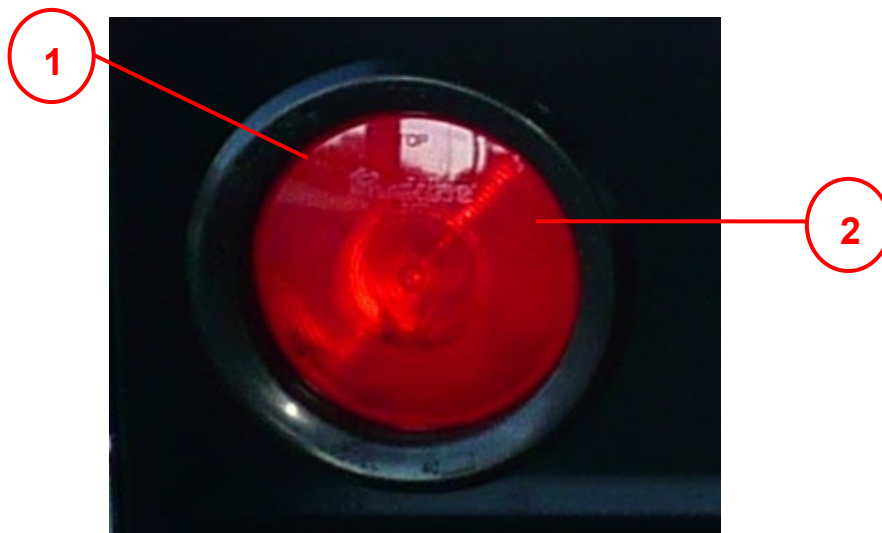
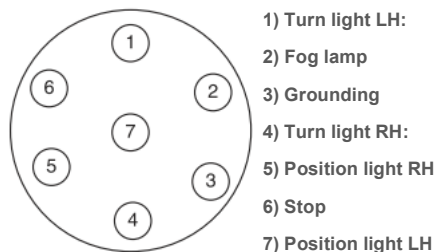

Figure 8.4-1 Rear light

##### SCHEMA SPINA A 7 POLI



**WARNING:** To replace the lamps, refer to the Maintenance chapter.



Date:	09/04/2024
Code	MAN D300T4F ENG
Revision	06

Motor compressor : D300T4F

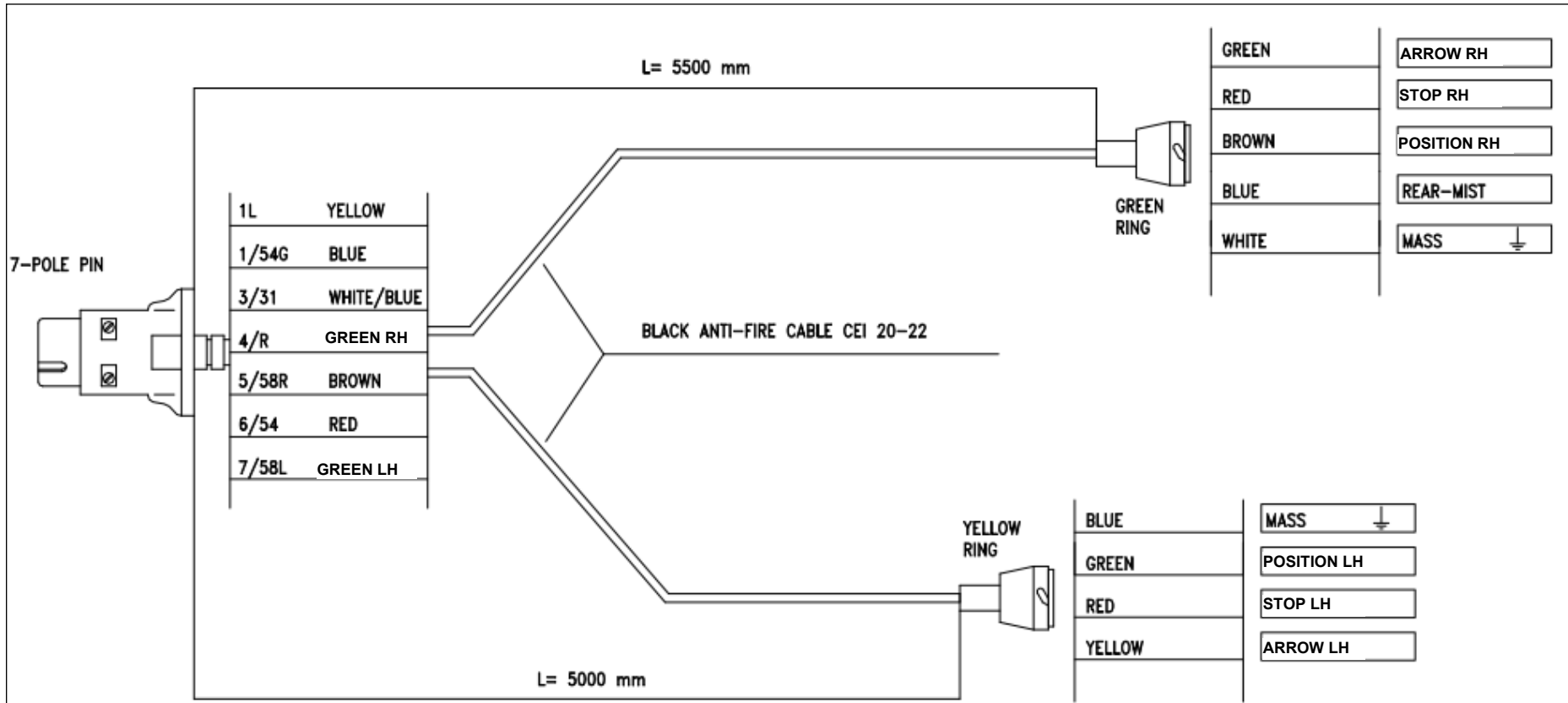

Figure 8.4-3 Light wiring harness



**9 HYDRAULIC AND PNEUMATIC SYSTEMS**

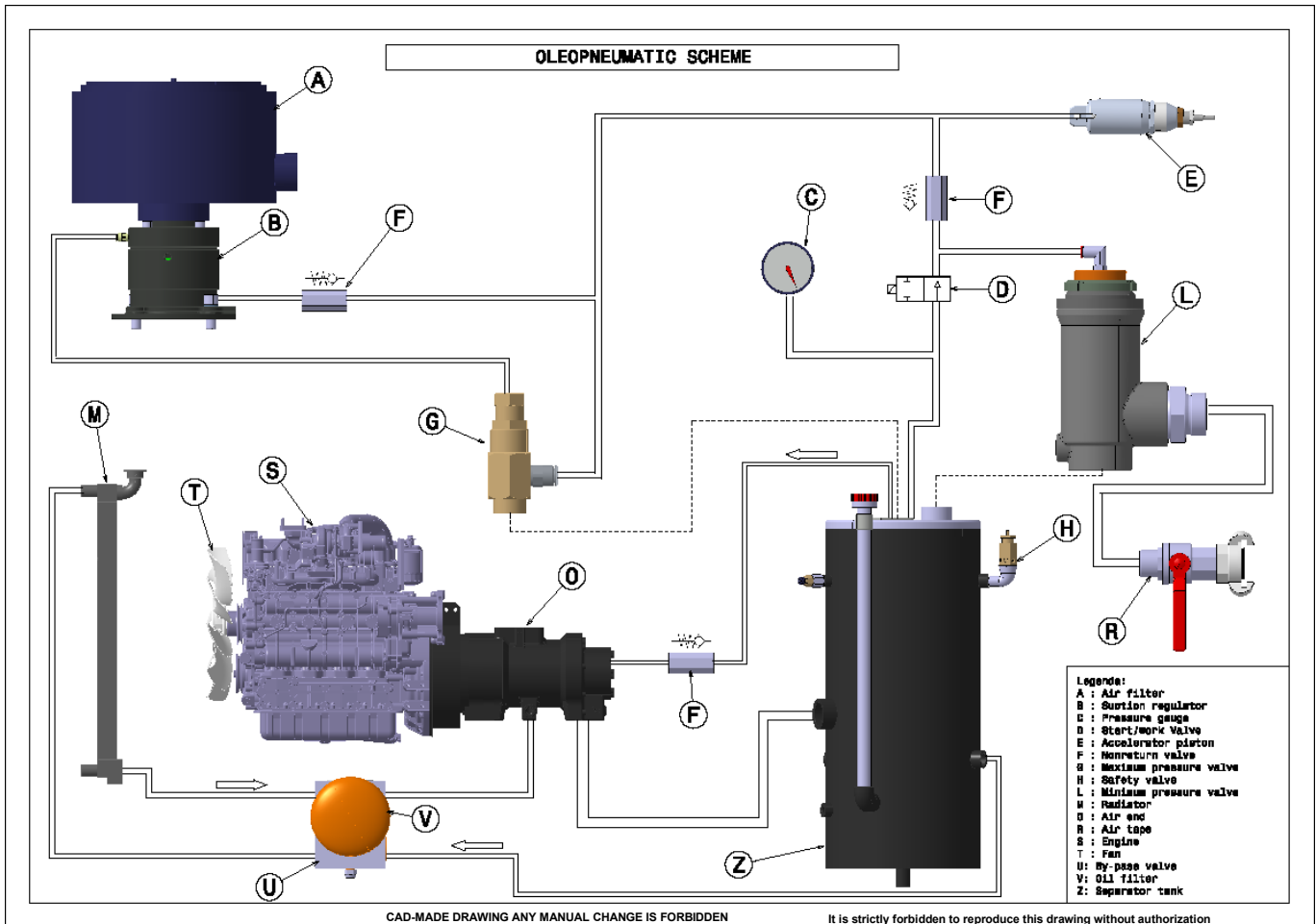

Figure 8.4-1 Hydraulic and pneumatic systems

**9.1 Hydraulic lubrication system**

The system includes the oil separator tank (Z), the thermostatic valve (U) on which, at the entrance, the oil filter (V) and the oil cooling radiator (M) are mounted.

As shown in fig.8.4-1 the lower part of the oil separator tank (Z) acts as an oil tank, with the filtering part is situated at the top which separates the air from the oil.

On starting up the machine, the pressure generated by the compressor, makes the oil inside the tank flow through the conduit in the direction indicated by the arrow. A thermostatic valve (U) is positioned along the route, which according to the actual oil temperature, conveys it all or partially to the cooling radiator (M), more specifically:

- at temperatures of below 65°C, the thermostatic valve remains open and the oil in circulation is directly injected into the compressor, without going through the radiator (M).

During the working cycle the oil is heated and when it reaches a temperature of 65°C, the thermostatic valve (U) begins to close, thereby making it necessary for part of the oil to go through the cooling radiator (M).

When the oil temperature reaches 75°C, the thermostatic valve (U) closed completely and from then on all the oil in circulation goes through the radiator and is thereby cooled (M).



From the radiator (M) the oil is injected into the compressor (O).

The filter (V) has an internal "by-pass" valve which permits oil circulation even if it gets blocked. In which case the oil will circulate regularly without being filtered. It is therefore necessary to replace the filter at regular intervals, as indicated in the maintenance programme.

The cooled and filtered oil thereby reaches the compressor (O) and by means of the various internal channels it is distributed to the various parts (rotors, bearings etc) which are thereby cooled and lubricated. From the compressor (O), the oil mixed with compressed air is sent to the tank (Z), inside which the separator undertakes to separate it from the air.

We have mentioned that the separator filter provides to separate the air from the oil; however a very small quantity is still able to penetrate the inside of the filter, and deposits itself on the low and concave part of the same. It is sucked through the piping on which the calibrated nozzle and the single-direction valve are positioned. The latter impedes the return of oil into the oil separator filter when the machine is stopped.



**WARNING: The filter needs therefore to be replaced at regular intervals, as specified in the maintenance program.**

## 9.2 Pneumatic system

The system includes: the suction filter (A), the suction regulator (B), compressor (O), tank (Z) and the oil separator element, the minimum pressure and non-return valve (L), the cock (R) and the maximum pressure valve (G), and the discharge solenoid valve (P).

The suctioned air, after having passed through the double stage filter (A) reaches the suction regulator, followed by the compressor which conveys it, together with the injected oil, into the oil separator tank. Where the air is separated from the oil. This separation process firstly comes about by means of centrifugal spinning and in the second stage with the use of the oil separator filter.

The air which is cleansed of the oil, is conveyed by the minimum pressure valve (L), and only opens when the pressure in the tank reaches the pre-set value. This minimum pressure formed in the tank guarantees oil circulation even when the air discharge taps (R) are in fully open position.

It is however a good idea not to use tools and equipment, which excessively consume compressed air, and which may cause the tank pressure to fall to below 5-5.1 bar.

In fact prolonged working conditions at below 5 bar, may cause compressor overheating, due to insufficient lubrication, and inadequate air and oil separation, resulting in excessive lubricant consumption.

The solenoid valve, on stopping the machine, opens automatically, gently discharging all the compressed air still inside the system into the atmosphere.

The minimum pressure valve (L) also acts as a single-direction valve, impeding return into the compressed air unit of air coming from channels or tools connected to the machine.



**WARNING: pressure vessel**

**9.2.1 AUTOMATIC ADJUSTMENT OF THE ENGINE RPM**

The system controls the speed of the diesel motor according to the compressed air taken in and consists of: maximum pressure valve (G), suction regulator (B), accelerator control piston (E), contrast spring (H).

- With motor on and the cock (R) fully open, the motor speed is at the maximum and the suction regulator is fully open.
- By slightly closing the cock (R) reduced air consumption is simulated with consequent increase in pressure in the tank (Z).
- On closing the cock (R), the pressure reaches the pre-set value and the maximum pressure valve (G) opens, allowing compressed air to flow out, which acts on the accelerator control piston (E) and beneath the suction regulator valve (B).
- Being stimulated by this pressure the piston (E) is able to exceed the contrast force of the spring (H), and by means of a lever system, the motor is proportionally decelerated.
- At the same time the suction regulation valve (B) also closed proportionally, thereby reducing the suction air passage. Therefore with cock (R) closed and with no air suction, the motor stabilizes at the minimum set speed while the suction valve (B) of the regulator reaches almost total closure position.
- In this stage of the cycle the suctioned air is minimal and it serves to compensate for any leakage within the circuit itself.
- At this stage the maximum final pressure will be indicated on the pressure gauge of the control panel.
- On resumption of air intake stage the maximum pressure valve (G) will start to close up and it will be totally closed when the pressure value falls to below approx. 1 bar in relation to the maximum final pressure value.
- During this stage the compressor delivers the maximum capacity to the working pressure as the spring (H), without the contrasting effect of the accelerator piston (E), accelerates the motor to maximum speed and the suction regulator valve reaches fully open position.
- In the event of use of tools with a consumption exceeding the nominal capacity of the compressor, a reduction in the pressure will be noted on the gauge, which must however never be less than 5 bar.
- Avoid any sudden opening of the cocks: they cause excessive stress on the oil separator filter and serious damage to the same.



	<b>USER'S AND MAINTENANCE MANUAL</b>	Date:	09/04/2024
		Code	MAN D300T4F ENG
<b>Motor compressor : D300T4F</b>		Revision	06

## 10 PROVISIONS FOR THE APPROPRIATE UTILIZATION OF THE MOTOR COMPRESSOR

Consult this user's and maintenance manual before starting-up the machinery.

### 10.1 Before starting-up

Before starting-up the machinery, strictly follow the instructions here in under:

1. Level the planarity of the machine by acting on the support foot or on the wheel: no incline greater than 15° is allowed;
2. make sure that the electric wires are connected to the battery terminals; if the connection is to be performed, use the greater care so that the cable coming from the starter motor is connected to the positive pole (+) of the battery and the earthing one is connected to the negative pole (-) of the battery.
3. Check the fuel level in the tank\*.
4. Check the level of the engine oil: as related to the types of lubricant and relevant quantities, comply with the prescriptions contained in the engine manufacturer's users and maintenance manual enclosed to the machinery documentation.
5. Check the oil level in the compressor: this operation must be performed not before than five minutes have passed from the time the machinery was stopped, and this to allow the lubricant in circulation to flow completely into the separator tank.
  - a) Before unscrewing the filler plug where the level gauge is attached, make sure that there is no longer pressure in the system. (The pressure gauge shall indicate 0 bar).
  - b) Take off the plug and clean the level gauge.
  - c) Thoroughly screw back the filler plug and then take it off again to verify that the lubricant level is included between the two marks (min. and max. level) engraved on the gauge.
  - d) Top up if required: the level must never exceed the max. mark.
  - e) Exclusively utilize the types of oil recommended in this user's and maintenance manual.



Figure 10.1-1 Checking the oil level in the compressor



**DIESEL**

\* Only use Diesel fuel for topping up.



	<b>USER'S AND MAINTENANCE MANUAL</b>	Date:	09/04/2024
		Code	MAN D300T4F ENG
<b>Motor compressor : D300T4F</b>		Revision	06

- 6 If the motor compressor is equipped with a liquid-cooling diesel engine, check the level of the cooling liquid contained in the radiator (Figure 10.1-3).



Figure 10.1-3 Checking the radiator cooling liquid

Recommended cooling liquid: ROLOIL ROL-ICE BLU



**WARNING:** *the radiator plug (Figure 10.1-3) must never be removed when the engine is hot: this would cause a sudden outflow of liquid which might cause severe scalding. Topping up - if required - must be made by means of a blend of water and anti-freeze liquid, in the percentage indicated on the container of the latter.*

## 10.2 Start-up

Operations to be performed for a correct start-up of the machinery:

- 1) By turning the starting block key (part. 4 Figure 8.1-1) to the right in the position "ON", the panel is powered and the following warning lights come on:

Engine oil pressure warning light

This indicates whether the engine oil circuit is in pressure (warning light off) or not (warning light on).

Alternator warning light

This indicates alternator efficiency.

Glow plug warning light

The first two warning lights are red and when the engine has been started they must be off.

The glow plug warning light stays on for as long as it takes to heat the glow plugs after which it switches itself off automatically. At this point it is possible to start the engine-compressor by the push button (part 3 Figure 8.1-1). The starter motor is powered by the push-button which will start the diesel engine.



<b>ELGI</b> <sup>TM</sup>	<b>USER'S AND MAINTENANCE MANUAL</b>	Date:	09/04/2024
		Code	MAN D300T4F ENG
<b>Motor compressor : D300T4F</b>		Revision	06



**WARNING:** Release the key at the first signs that the diesel engine is starting.  
Do not run any lengthened starts, above 10 seconds.  
In case of difficult start-up, repeat the maneuver with short start-ups at intervals.

- 1) Wait for a few minutes, until the engine warms up. The pressure shall raise up to the max, pressure of the machinery. If one or more lamps were still lit, immediately stop the machinery and identify the cause.
- 2) Then connect the compressed air ducts to the relevant tools.
- 3) Progressively open the taps (Letter A Figure 10.2-1).



**WARNING:** It is forbidden to open the machinery with the engine hood open.

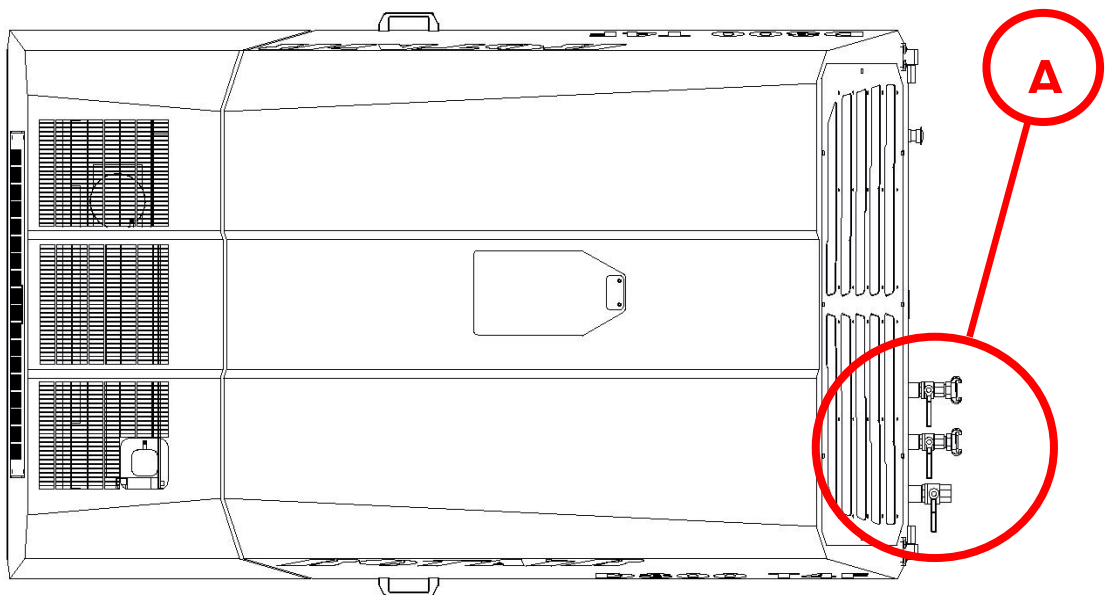



Figure 10.2-1 Location of the taps (top view)



**WARNING:** Do not breathe the compressed air produced by this unit in output from the taps



	<b>USER'S AND MAINTENANCE MANUAL</b>	Date:	09/04/2024
		Code	MAN D300T4F ENG
<b>Motor compressor : D300T4F</b>		Revision	06

### 10.3 During the work cycle



The machine must always operate with the hood down and closed.

During the work cycle it is necessary to verify that the intake openings are free of foreign bodies such as pieces of paper, plastic, etc ... as these materials can create obstructions to the ventilation system.



Figure 10.3-1 Exhaust pipe



**WARNING:** *in the vicinity of the exhaust pipe are very hot exhaust gases and harmful. Avoid the stop in the vicinity of the exhaust pipe*

### 10.4 Stop

By turning the *starting block key* (Part.4 Figure 8.1-1) to the left in the "OFF" position the pressure in the tank lowers up to 3-3,5 bar.

As soon as the pressure reaches 3-3,5 bar the engine automatically stops.

In machines approved for road use the electrical system is completed by lighting wiring. In the table, the wire connections inside the 7-pole socket are given and their connection to the rear light apparatus. This system is connected directly to the towing machine via an extension lead which is supplied with the engine-compressor.

### 10.5 After stopping the machine

- 1) If the machine has operated in dusty environments, it will be necessary to clean or replace the air filter and check the status of cleaning the cooling radiator; where this is clogged, it will proceed as indicated in paragraph maintenance.
- 2) Check that during the working phase there are no losses of fuel or lubricating oil inside the machine
- 3) Where possible place the machine away from the elements.



**11 MONITORING AND TESTING OF THE MACHINE****11.1 Monitoring and testing of engine speed**

ALL TESTING AND CALIBRATION SYSTEMS MINIMUM AND MAXIMUM, MUST BE DONE BY A PROFESSIONAL, INFORMED, FORMAT AND TRAINED, EQUIPPED WITH A SPECIAL EQUIPMENT TACHYMERIC A STRIKER REFLECTIVE AND EQUIPPED WITH HEADPHONES NOISE.



*For all calibrations and adjustments we highlight the following residual risks*



Presence of organs of motion. Pay attention to mechanical risks.



The presence of hot surfaces at high temperatures. Pay attention to the risk burn.

**11.1.1 CONTROL SYSTEM OF MAXIMUM ENGINE SPEED**

The calibration of the maximum speed is set by the manufacturer. It should not be changed for any reason. Any tampering or variation of the maximum speed of rotation of the motor will cause an immediate voiding of the warranty.



**11.1.2 CONTROL SYSTEM OF MINIMUM ENGINE SPEED**

Figure 11.1-1 Adjusting idle speed motor

For calibration of the idle speed of the engine revs qualified maintenance personnel must do the following:

1. Start the machine as described in section 10.2 "Start"
2. Wait for the compressor reaches the maximum pressure and the engine stating the values of idle speed;
3. Close all faucets (Letter A in Figure 10.2 1);
4. Open the bonnet with the compressor in motion;
5. Unscrew with wrench 23 mm, the nut (Letter A in Figure 11.1 1);
6. If you want to increase the idle speed of the engine, you must tighten the lock nut by an 18-mm wrench (Letter B in Figure 11.1 1).
7. If you want to reduce the idle speed of the engine, you must loosen the lock nut by an 18-mm wrench (Letter

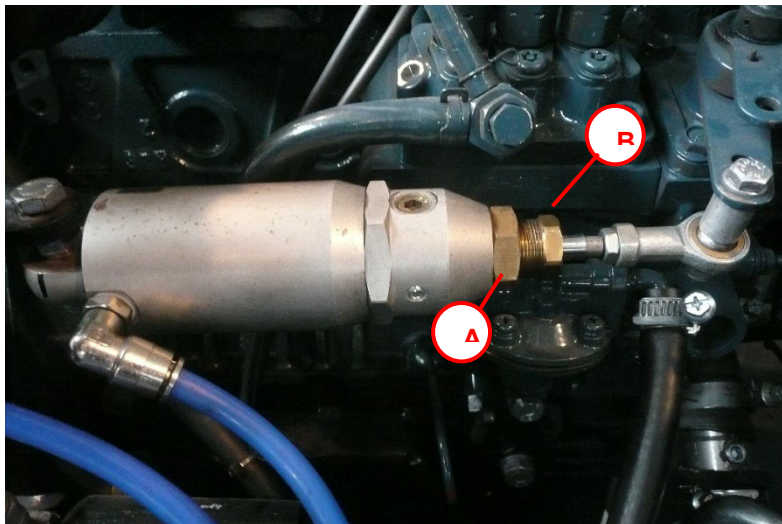

	<b>USER'S AND MAINTENANCE MANUAL</b>	Date:	09/04/2024
		Code	MAN D300T4F ENG
<b>Motor compressor : D300T4F</b>		Revision	06

B in Figure 11.1 1).

8. Measure with an optical tachometer (Letter B in Figure 11.1 2) the speed of rotation (in revolutions / minute) of the motor hub focusing the optical beam on the speedometer notch Reflective (Letter A in Figure 11.1 2);
9. Compare the measured value with that reported in Paragraph 2 a tolerance of  $\pm 2/3\%$  between the two values
10. Adjust the speed of the motor hub, as described above, to the value of idle speed indicated in paragraph 2 of this manual;
11. Once the adjustment screw, with a 23 mm wrench, nut (Letter A in Figure 11.1 1);
12. Close the bonnet.

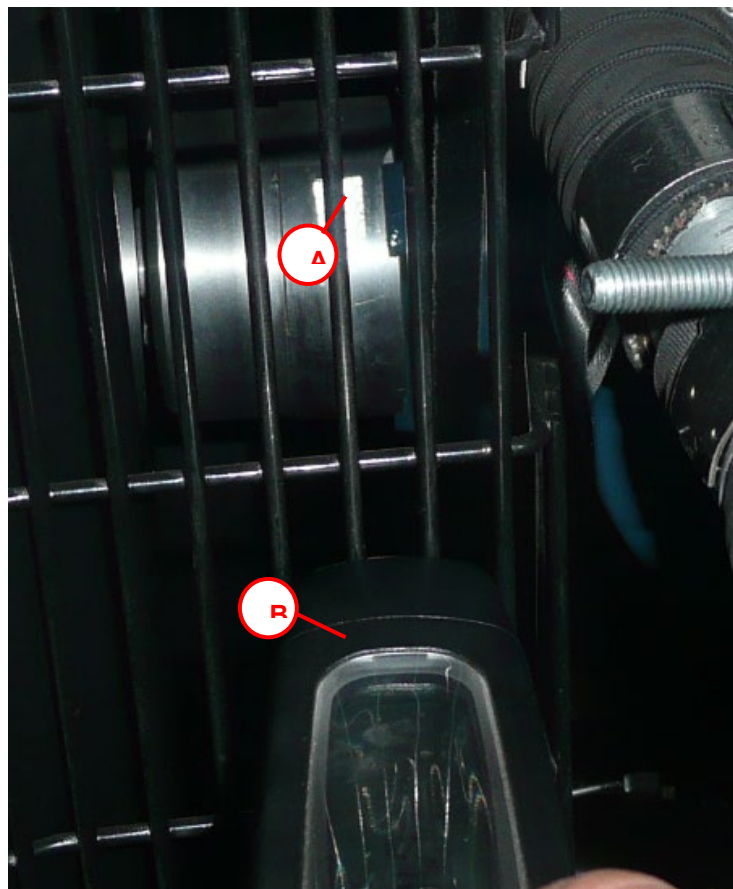



Figure 11.1-2 Measurement speed rotating motor hub



	<b>USER'S AND MAINTENANCE MANUAL</b>	Date:	09/04/2024
		Code	MAN D300T4F ENG
<b>Motor compressor : D300T4F</b>		Revision	06

## 11.2 Monitoring and control of the air pressure of the compressor

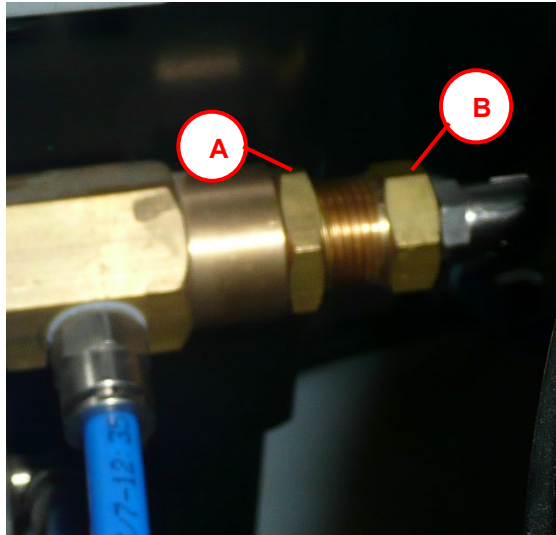

Figure 11.2-1 Adjusting maximum pressure pneumatic circuit

The maximum pneumatic pressure is calibrated during the testing phase of the machine.

If the value of the maximum pressure pneumatic, indicated by the pressure gauge on the control panel, diverged over a  $\pm 5\%$  from the value specified in Paragraph 2 of this manual, proceed as follows:

1. Start the machine as described in section 10.2 "Start",
2. Wait for the compressor reaches the maximum pressure and the engine stating the values of idle speed;
3. Close all faucets (Letter A in Figure 10.2 1);
4. Open the bonnet with the compressor in motion;
5. Unscrew with wrench 22 mm in, the nut (Letter A in Figure 11.2 1); Air filter area:
6. If you want to increase the maximum pressure must tighten with 19 mm wrench, nut (Letter B in Figure 11.2 1);
7. If you want to reduce the regime min unscrew, with a 19 mm wrench, nut (Letter B in Figure 11.2 1);
8. Once the adjustment screw, with a 22 mm wrench, nut (Letter A in Figure 11.2 1);
9. Slightly open for 3/4 seconds, the faucet supply air to the engine to accelerate, and then close it. Repeat this 2-3 times to allow the settling of the valve.
10. Reading on the pressure gauge located in the control panel, the value of the maximum pressure reached;
11. Compare the measured value with that reported in Paragraph 2, repeat the steps up to the alignment of the two values;
12. Close the bonnet.



**WARNING:** Notice: if the gauge had a discontinuous, jerky, you will have to replace it. So, before making any calibration valve high or low pressure, make sure that the gauge is efficient and reliable.



### 11.3 Monitoring and control of air pressure minimum compressor

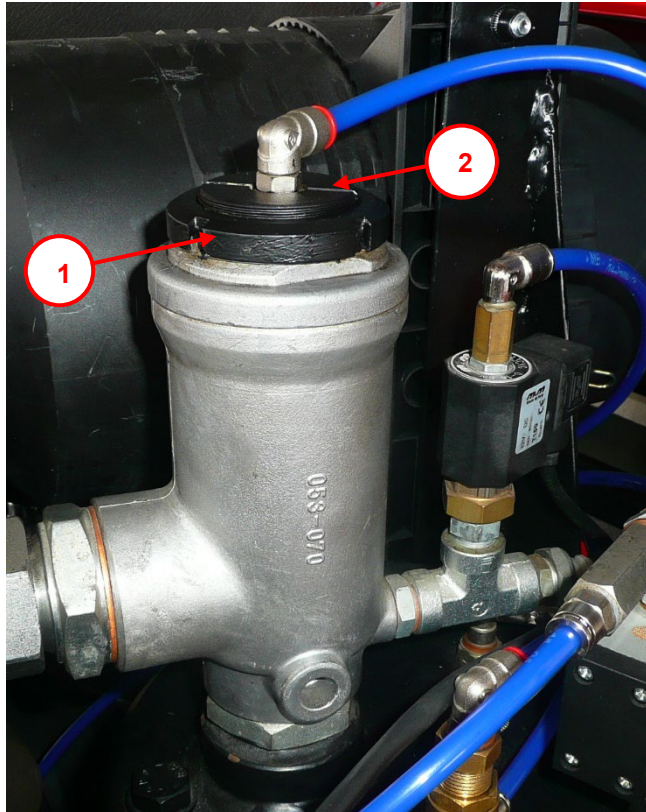

Figure 11.3-1 Adjusting minimum pressure pneumatic circuit

The minimum pneumatic pressure is calibrated during the testing phase of the machine.

If the minimum pressure pneumatic, indicated by the pressure gauge on the control panel, diverged over a  $\pm 5\%$  from the value specified in Paragraph 2 of this manual, proceed as follows:

1. Start the machine as described in section 10.2 Start.
2. Wait for the compressor reaches the maximum pressure and the engine stating the values of idle speed;
3. Gradually open the air valve (Letter A in Figure 10.2-1);
4. Open the bonnet with the compressor in motion;
5. Release the lock-nut (1).
6. Tighten the regulation screw (2) to increase the pressure to the desired value.
7. Loosen the regulation screw (2) to reduce the pressure to the desired value
8. Tighten the lock nut (1) and close the cocks.
9. Slowly re-open the air cock and then close it again repeating the operations several times in order to permit the valve to settle into place.
10. Reopen slowly the air tap (Letter A Figure 10.2 1) and close it again repeating the process a few times to allow the settling of the valve;
11. Close the bonnet.



**WARNING:** *Pressure vessel*



	<b>USER'S AND MAINTENANCE MANUAL</b>	Date:	09/04/2024
		Code	MAN D300T4F ENG
<b>Motor compressor : D300T4F</b>		Revision	06



## 12 SAFETY DEVICE (ONLY EU VERSION)

PRESENT	SAFETY DEVICE	FUNCTION
	Top buttons with rearmament rolling (fungus)	Immediate stop of the machine. Intervenes by switching off power to the electrical circuits.

### 12.1 Emergency stop buttons

On board the machine is installed an emergency stop button with self-restraint type "fungus" according to EN 418, red or yellow with priority in all operating modes with respect to other functions and activations. In case of need the machine can be locked immediately by pressing the emergency button. After pressing the power supply is cut.

#### 12.1.1 OPERATION OF THE EMERGENCY BUTTON

	Press this button to stop the machine in emergency conditions. <b>WARNING:</b> Use only for emergency and not to turn off the machine normally.
	To restore the normal working conditions, in the event of an emergency stop due to the pressure of the above buttons, the following procedure should be followed: <ul style="list-style-type: none"> <li>• Remove the cause that prompted the shutdown of the machine;</li> <li>• Turn out the emergency stop button pressed;</li> <li>• Operate the power switch turning off and on the machine.</li> </ul>



## 12.2 Verification of the safety valve

The safety valve is located on the oil separator tank and starts working to download any accidental overpressure.

The calibration of this valve is performed and verified in the testing of the factory and cannot be varied for any reason or tampered with.

Its efficiency should be checked quarterly by doing the following:

- 1) Start the machine the machine as described in section 10.2 "Start"
- 2) With the valves closed and with the engine at idle speed, using forceps, pick up the pin, as shown in Figure and release it as soon as you have the perception that the valve exhausts air.

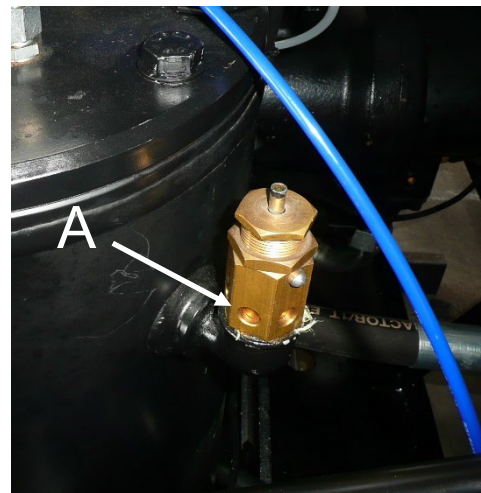
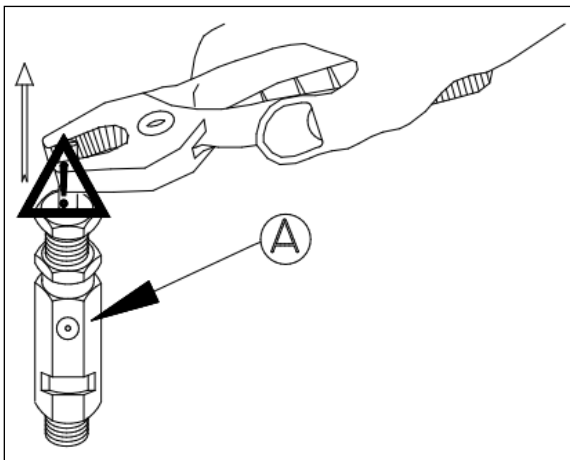

Figure 12.2-1 Control of the safety valve



**WARNING:** The air escaping from the valve during this operation control is also composed of small particles of oil.



**WARNING:** Pay attention to the danger of projection of liquids.



If, following the traction using a clamp, the pin is not raised, thus preventing the valve to vent, will require an immediate replacement of the same.



In case of replacement, it is recommended to contact the service ELGI, quoting the serial number of the machine.

*The use of a safety valve is not original and does not comply, the ELGI exempt from any liability.*

	<b>USER'S AND MAINTENANCE MANUAL</b>	Date:	09/04/2024
		Code	MAN D300T4F ENG
<b>Motor compressor : D300T4F</b>		Revision	06

## 13 MAINTENANCE



The machine must be subjected to regular periodic maintenance in order to keep unchanged the technical characteristics, and safety originate.

Maintenance work must be performed by qualified personnel of patterns and designs, the machine stopped and power switched off to the electrical panel. Therefore, all maintenance must be carried out only after turning off the machine.



The staff of the service maintenance has to check that they have withdrawn their tools at the end of surgery and before starting the machine again, to avoid damage to the moving parts.

### 13.1 Routine maintenance

Means with **routine maintenance**, all the maintenance actions that its sole objective was to bring back a system (or one of its components) from a state of failure, the state is working properly before the onset of the problem, without changing or improving the functions performed by the system, nor to increase the value, or improve performance.

Maintenance includes all those periodic operations including:

In the following chapter are listed in order of frequency, all transactions concerning the compressor part, while as regards the part of the engine, it will be necessary to refer to OPERATING AND MAINTENANCE, which is prepared by the manufacturer of the engine and that is as supplied with the machine



	<b>USER'S AND MAINTENANCE MANUAL</b>	Date:	09/04/2024
		Code	MAN D300T4F ENG
<b>Motor compressor : D300T4F</b>		Revision	06

### 13.2 Maintenance program

In this program are listed all the interventions and their frequency to be executed on the various components of the machine. Such interventions are essential for the proper functioning of the machine and its mechanical durability over time.

<b>RECOMMENDED OPERATIONS</b>	<b>FREQUENCY</b>
Checking the oil level compressor	Daily
Check engine oil level (refer to the manufacturer's manual)	Daily
Checking Coolant Level	Daily
Check fuel level and top up (if necessary)	Daily
Check oil or fuel leakage	Daily
Check operation indicator lights	Daily
Check the readability of measuring instruments	Daily
General cleaning operations	Daily
Control of the absence of obstructions to the ventilation system	Daily
Control the Compressor air filter	Every 100 hours
Control Compressor air filter in dusty conditions	Daily
Check operation lights and license plate lights (only for the approved version of the road)	Daily
Control of the air filter Compressor	weekly
Control of the engine air filter	(Ref. Manual of the engine manufacturer).
Checking the battery electrolyte level	Monthly
Checking tire pressure	Monthly
Checking belt tension Quarterly	Three months
Speed control the minimum and maximum engine	Three months
Control of the efficiency of the safety valve	Three months
Cleaning the oil cooler	Three months
Control nozzle oil recovery	Three months
Drainage of the fuel tank	Three months
Replacing diesel pre-filter	Every 500 hours
Control of the efficiency of the braking system	Three months
Control and wheel lock	Three months
Change engine oil	(Ref. Manual of the engine manufacturer).
Oil Filter Replacement compressor	After the first 50 hours
Replacing compressor oil	After the first 50 hours
Control of tightening screws and bolts of the compressor and engine silent-blocks	Every 50 hours
Control of tightening screws and bolts	Every 100 hours
Check tightness of all pipe connections	Every 100 hours
Replace Air Filter Compressor	After 500 hours
Replace oil filter compressor	After 500 hours or after a long storage period (9-12 months) whichever comes first



	<b>USER'S AND MAINTENANCE MANUAL</b>	Date:	09/04/2024
		Code	MAN D300T4F ENG
<b>Motor compressor : D300T4F</b>		Revision	06

<i>RECOMMENDED OPERATIONS</i>	<i>FREQUENCY</i>
Replacing compressor oil	After 1500 hours
Replacing oil separator element	After 2000 hours
Check-up by the service "authorized ELGI ".	Every 3000 hours
Control readability nameplate EC Annual	Annual
Control valves from service "authorized ELGI ".	Biennial



The ELGI disclaims any responsibility for the failure to comply with maintenance requirements in the table above.



### 13.3 Values of tightening screws and bolts

For the correct tightening of screws and bolts on the machine please observe the tightening values corresponding to the class of coupling illustrated in the table below.

We recommend the use of torque wrenches for tightening the screws and bolts on the machine.

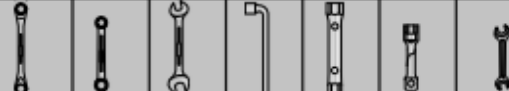
Torques not binding N.m (Newton meters)							Couples test sockets for hexagonal screws													
<p>These pairs are reference values for normal metric threads according to DIN ISO 261 and measures supporting heads according to DIN EN ISO 4762, DIN ISO EM 4032, DIN EN ISO 4014 and DIN 931-2, 6912, 7984 and 7990. With these values obtains an exploitation of 90% of the yield strength of the screws, on the basis of a coefficient of friction equal to 0.14 (screw new, untreated, not lubricated). Important: In extreme cases, e.g. screws lubricated with MOS2 and coupling elements cadmium-plated on both sides, the value of torque should be reduced by about 20%.</p>							No. 2, 2A, 2B		No. 4		No. 6, No. 1B, 7, 400		No. 25		No. 26 R No. 626		No. 35 A No. 35 B No. 3112		No. 894 No. 895	
							No. 1B, 308, 7													
	Tightening values for classes of coupling according to DIN 267																			
	4.6	5.6	6.9	8.8	10.9	12.9														
M 2	0,123	0,162	0,314	0,373	0,520	0,628	4			1,90										
M 2,2	0,196	0,265	0,510	0,598	0,843	1,010	4,5*			2,64										
M 2,5	0,284	0,373	0,726	0,863	1,206	1,451	5			3,55										
M 3	0,441	0,588	1,128	1,344	1,883	2,256	5,5			4,64		14,4			2,32					
M 3,5	0,677	0,902	1,736	2,060	2,893	3,481	6*	17,6	7,4	5,92		17,6			2,96					
M 4	1,000	1,344	2,599	3,040	4,315	5,148	7	25,2	11,4	9,12		25,2			4,56					
M 5	1,916	2,648	5,099	6,031	8,483	10,200	8 9*	34,5 45,4	16,6 23	13,3 18,4		34,5 45,4	34,5 45,4	6,65 9,20						
M 6	3,432	4,511	8,728	10,300	14,710	17,652	10	58,1	31	24,8	58,1	58,1	58,1	12,4						
M 7	5,590	7,453	14,220	17,162	24,517	28,439	11 12	72,7 89,1	40,4 51,5	32,3 41,2	72,7 89,1	72,7 89,1	72,7 89,1	16,1 20,6						
M 8	8,238	10,787	21,575	25,497	35,304	42,168	13 14*	107 128	64,5 79,4	51,6 63,5	107 128	107 128	107 128	25,8 31,7						
M 10	16,67	21,575	42,168	50,014	70,608	85,317	15 16 17	150 175 201	96,2 115 134	77,0 92,3 107	150 175 201	150 175 201	150 175 201	38,5 46,1 53,5						
M 12	28,44	38,246	73,550	87,279	122,60	147,10	18 19* 20*	230 261 294	160 186 215	128 149 172	230 261 294	230 261 294	230 261 294	64,0 74,5 86,0						
M 14	45,11	60,801	116,70	138,30	194,20	235,40	21 22* 23*	330 368 408	247 281 319	198 225 255	330 368 408	330 368 408	330 368 408	99,0 112 127						
M 16	69,63	93,163	178,5	210,80	299,10	357,90	24 25* 26*	451 496 544	359 402 449	287 322 359	451 496 544	451 496 544	451 496 544	143 161 179						

### 13.4 Maintenance

#### 13.4.1 CHECKING AND CLEANING AIR FILTERS AIR INTAKE

This check should be performed periodically every 100 hours of work;

If the machine operates in a very dusty environment, it will also be necessary on a daily basis.

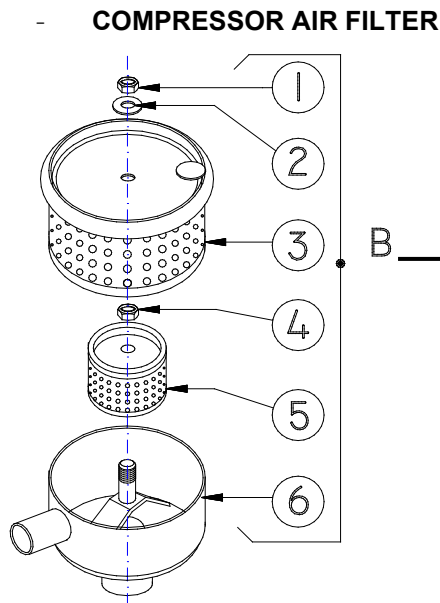

Figure 13.4-1A Aspiration air filter

For cleaning or replacement cartridge, proceed as follows:

1-The filter consists of two filtering cartridges (1<sup>st</sup> and 2<sup>nd</sup> stage): to check them loosen the nut (fig.13.4-1A part 1) and extract the cartridge of the 1<sup>st</sup> stage part 3.

2- Should any traces of dust be noticed on the cartridge of the 2<sup>nd</sup> stage also part 5, extract this one also, unscrewing the nut part 4.



**The filter cartridge must never be washed with water or other substances and never cleaned with compressed air but replaced;**



**It must, however, be replaced every 500 hours of work.**

	<b>USER'S AND MAINTENANCE MANUAL</b>	Date:	09/04/2024
		Code	MAN D300T4F ENG
<b>Motor compressor : D300T4F</b>		Revision	06

### 13.4.2 CONTROL THE ELECTRICAL BATTERY



#### Extended not-use of the machine - battery charge status



- To avoid complete discharge of the battery, if the machine is not to be used for > 3 months, disconnect the negative terminal of the electrical system.
- Periodically check the battery charge and recharge it every 3 months.

#### Cleaning the terminals

The battery terminals (poles) must be cleaned and greased periodically. The accumulation of dirt can hinder the passage of electric current.

For cleaning it is necessary to switch off the machine, disconnect the terminals starting from the negative terminal and clean the terminals.

#### Checking the clamps

Generally the negative and positive pole of the battery are greased (eg. Pulp vaseline or similar product) to avoid the oxidation of metals. The paste on the clamps must be periodically replaced.

In the same way, check that the terminals are firmly connected to the battery poles and if necessary tighten them. In fact, it may happen that vibrations loosen the grip of the clamps. A mobile connection can cause malfunctions and even failures to the vehicle's electrical devices.

#### Checking the battery fluid (in the case of an unsealed battery)

The electrolyte must always reach the covering level of the element plates.

If the battery fluid is low, it may compromise its operation.

In these cases, if the level of covering is below the minimum level it is necessary to have it checked by a qualified electric maintenance technician and if necessary to provide the addition of cold water distilled water to restore the liquid level.

If, despite top-up, the battery continues to discharge frequently, it must be replaced.



**CAUTION: Take special care when handling battery fluid. Potentially corrosive liquid.**



	<b>USER'S AND MAINTENANCE MANUAL</b>	Date:	09/04/2024
		Code	MAN D300T4F ENG
<b>Motor compressor : D300T4F</b>		Revision	06

### 13.4.3 FUSE REPLACEMENT

Fuse replacement should be performed when one or both fuses were damaged or not intervene.

To replace the fuse proceed as follows:

- 1) Stop the machine;
- 2) Open the bonnet;
- 3) Open the fuse box;
- 4) Pull the fuse to be replaced with tweezers (to fuse 15 A), and unscrew the screws for the 40 A fuse:
- 5) Once removed the fuse concerned, observe the internal filament, this must be intact to function properly, if this is the case simply up item. If this filament is sectioned into two means this is to be replaced;
- 6) In the event of a damaged fuse replace it by choosing a fuse with identical characteristics. The characteristics of the fuses are described 8.3in this manual;
- 7) After inserting the new fuse in the housing close the fuse box;
- 8) Close the bonnet;
- 9) Now you can restart the machine.



### 13.4.4 REPLACEMENT LAMPS LIGHT (FOR VERSION APPROVED)

For the replacement of a bulb must procedures as listed below:

- 1) Stop the machine;
- 2) Open the cover of the headlight using a screwdriver to remove the four screws of the lamp
- 3) Unscrew the light bulb;
- 4) Screw in a new bulb taking into account the value of the corresponding power (see table below);
- 5) Close the cover of the headlight using a screwdriver to screw the four screws of the headlights

Headlight composition		
Type of bulb	Power bulb	Number of bulbs
Lamp position, stop *	5/21 W	1
Signal light bulb	21 W	1
License plate lamp and rear fog	21 W	1

\* The lamp position/stop double stranded vary its own light intensity depending on the use of the brake



**13.4.5 TYRE PRESSURE MONITORING**

**Make sure that the tire is "cold", i.e., that has driven more than 2 km, so that the air inside is not already expanded.**

The nominal pressure of the tire expressed in BAR is 2.4 atm

**Unscrew the valve cap from the tire.** The valve is a tube of black metal placed near the hubcap, about 2-3 cm long.

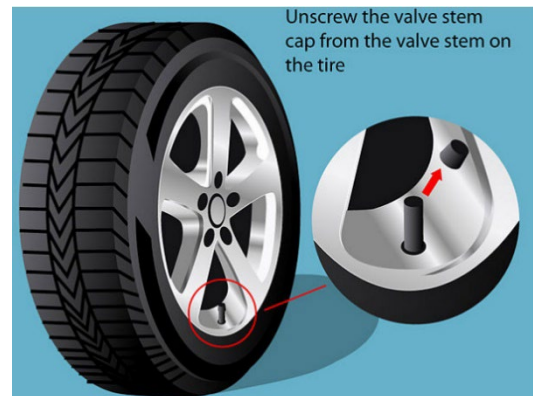

**Place the gauge on the valve and read the value reported.** If you hear a "breath", it means that the gauge was not properly connected and the measurement will not be reliable. You may need to reallocate the valve of the pressure gauge.

**If the pressure of the tire conforms to the parameters indicated in Chapter 2 of this manual, there is nothing left to do but check the remaining tires. If the pressure is lower, you must enter the air in the tire checking the value measured by the manometer**



**Replace the valve cap.**

The cap serves to keep clean and to protect the valve mechanism from dust and moisture.

	<b>USER'S AND MAINTENANCE MANUAL</b>	Date:	09/04/2024
		Code	MAN D300T4F ENG
<b>Motor compressor : D300T4F</b>		Revision	06

#### 13.4.6 CLEAN THE RADIATOR COOLER

The coolants of the compressor and the motor are cooled by a radiator which, consequently, must be kept clean so that the ventilation air can pass freely and easily through its fins honeycomb.

A radiator fins clogged with dust or any other bodies, because of the harmful and dangerous overheating to the mechanical screw compressor, greatly jeopardizing the operation and durability. We recommend that you check it periodically and, if necessary, clean it with compressed air or clean it with a jet of water under pressure.

#### 13.4.7 PERCENTAGE DOSAGE OF COOLING LIQUID

To determine the proper amount of antifreeze to be paid within the tank of the radiator (Figure 13.4-3) must follow the following table:

T (°C / °F)	Total volume of the cooling plant (lt - gal)	Water volume (lt - gal)	Antifreeze volume (lt - gal)	Antifreeze percentage*
(°C / °F)				%
- 10 / 14	18 – 4,75	13,5 – 3,55	4,5 – 1,20	25%
- 15 / 5	18 – 4,75	11,7 – 3,10	6,3 – 1,65	35%
- 20 / -4	18 – 4,75	10 – 2,65	8 – 2,10	45%

\*Cooling liquid suggestions: ROLOIL ROL-ICE BLU



Figure 13.4-3 Checking the coolant radiator



**WARNING:** He radiator cap (Figure 10.1-3) must never be removed in a warm engine: in this condition would occur a sudden leakage, which could cause serious burns to the person. The possible filling must be done with a mixture of water and antifreeze liquid, in the percentage indicated on the container of the latter.



	<b>USER'S AND MAINTENANCE MANUAL</b>	Date:	09/04/2024
		Code	MAN D300T4F ENG
<b>Motor compressor : D300T4F</b>		Revision	06

#### 13.4.8 CHECKING AND CLEANING NOZZLE OIL RECOVERY

Control and clean the oil recovery is to be performed, should you find a leak of oil mist mixed with air compressed, operating as follows (Figure 13.4-4).

- 1) Unscrew the fitting located at the center of the tank (Letter Z in Figure 13.4-4);
- 2) Inside the ring (Letter Z in Figure 13.4-4) is a nozzle (Letter U in Figure 13.4-4): make sure that its calibrated hole is not blocked (blow with compressed air);
- 3) Replace the fitting.



**WARNING:** During normal operation of the compressor, in the pipe from the fitting transparent part (Z), you will notice a certain amount of oil flow from the said fitting (Z) towards the head of the compressor

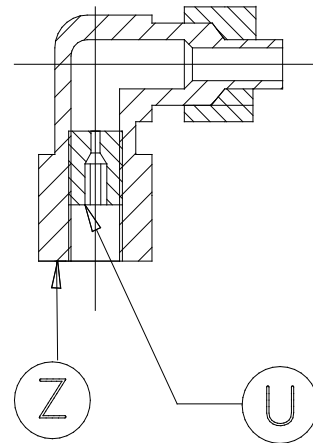
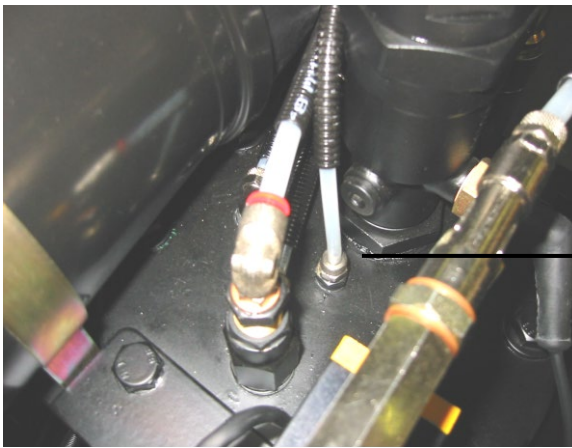

Figure 13.4-4 Nozzle oil recovery

#### 13.4.9 DRAINAGE OF THE FUEL TANK

The draining of the fuel tank has the aim to eliminate the water possibly settled on the bottom of the tank due to the formation of condensation or refilling fuel polluted.

Avoid fuel filling with cans because sometimes, these may contain traces of water which, being heavier than the gas oil, is deposited on the bottom and can build up to reach the level of the dip tube.



Periodically carry out the drains to prevent even small parts of water can be aspirated and injected into the engine.

It is also advisable to carry refuel at the end of the work shift to prevent the temperature range of the tank walls make possible the formation of condensation inside it.

In conjunction with the drainage of the tank, also proceed to the replacement of the fuel filter to eliminate from the fuel every trace of water.



The draining of the tank must be performed at least 30 minutes after stopping the machine, to allow water to separate from the diesel fuel and to settle to the bottom of the tank.



	<b>USER'S AND MAINTENANCE MANUAL</b>	Date:	09/04/2024
		Code	MAN D300T4F ENG
<b>Motor compressor : D300T4F</b>		Revision	06

The polluted fuel spilled from the purges should be collected and delivered to specialized centres and authorized the collection and disposal of hazardous waste.



*Remember that the residual fuel should not be totally discarded in the environment.*

#### 13.4.10 REPLACING DIESEL PRE-FILTER AND FILTER

To replace the pre-fuel filter and filter see the user's manual of the engine, prepared by the manufacturer, attached to the documentation provided with the machine.



#### 13.4.11 CHECK BREAK DEVICE



For this and for the replacement of the brake drum see the user's manual of the group-axle brake-repulsion, prepared by the manufacturer, attached to the documentation provided with the machine.



	<b>USER'S AND MAINTENANCE MANUAL</b>	Date:	09/04/2024
		Code	MAN D300T4F ENG
<b>Motor compressor : D300T4F</b>		Revision	06

#### 13.4.12 CONTROL OF LOCKING WHEEL BOLTS

Periodically check the tightness of the wheel bolts using a spanner, avoiding the use of air screwdrivers that may damage the bolt threads.

#### 13.4.13 OIL FILTER REPLACEMENT COMPRESSOR

For proper filter replacement compressor oil must do the following:

- 1) Stop the machine and open the hood of the engine compartment;
- 2) Use a chain wrench to unscrew the filter to be replaced (A - Figure 13.4-6);
- 3) Oil the seal of the new filter to be tightened and by hand only;
- 4) Start up the machine and make sure that there are no oil leaks in the vicinity of the seal, in this case to stop the machine and recheck the status and the correct positioning of the seal in its housing.

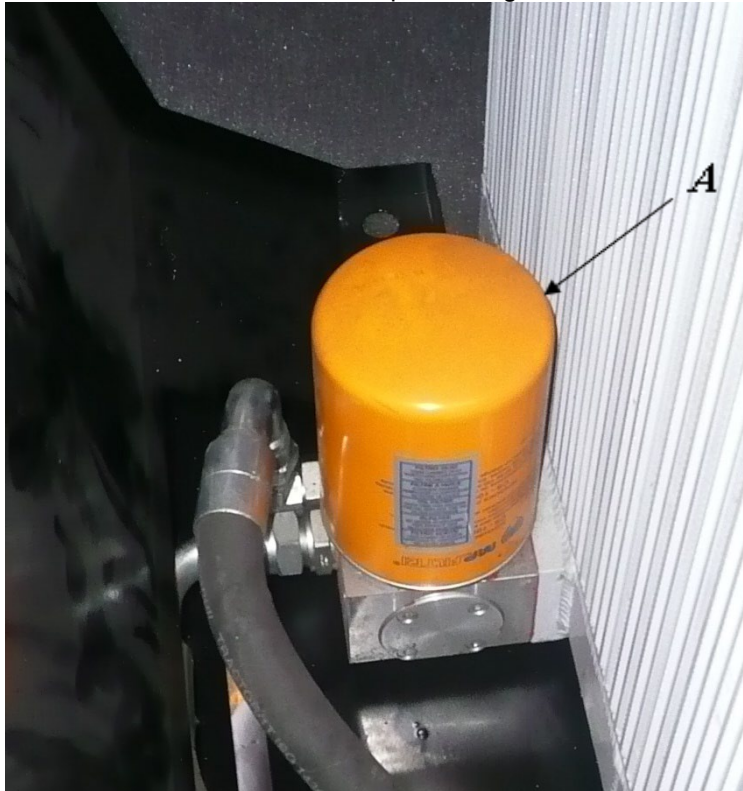

Figure 13.4-6 Compressor oil filter



**WARNING:** The filter is impregnated exhausted mineral oil pollution and harmful to the environment, therefore it must be disposed of at specialized centres of collection and treatment of waste.



**WARNING:** Replace the compressor oil filter after 500 hours or after a long storage period (9-12 months) whichever comes first before.



	<b>USER'S AND MAINTENANCE MANUAL</b>	Date:	09/04/2024
		Code	MAN D300T4F ENG
<b>Motor compressor : D300T4F</b>		Revision	06

#### 13.4.14 REPLACEMENT OF COMPRESSOR OIL

The oil compressor must be performed taking into consideration the working conditions in which the machine operates (dusty, very high temperatures, etc.).

The oil change intervals must never exceed 2,000 hours of work.

In conjunction with the replacement of the oil must be changed, the corresponding filter (Paragraph 13.4.13).

RECOMMENDED OIL	QUANTITY	PART NUMBER
AIRLUBE PORTABLE LUBRICANT	2.5 Gallons	512-12-0000
	5 Gallons	512-12-0001
	55 Gallons	512-12-0002
	330 Gallons	512-12-0003



**WARNING:** It is strictly recommended to use ONLY OIL FOR SCREW COMPRESSORS. ELGI declines any responsibility if other oils will be used.



#### 13.4.15 CHECKING THE OIL MIST SEPARATOR

Filter life oiler is expected around 2000 hours of work, but is closely related to a careful observance of all maintenance requirements given in this manual.

A quantity of oil or excessively low in the tank, the breach of the frequency of oil changes or the use of the machine with cooling radiator clogged may determine an anticipated and irreparable deterioration of the filters. Therefore, if, after the control and clean the recovery (operation described in the paragraph 13.4.8) and making sure the proper oil level in the tank, you are still traces of oil in the compressed air, is will have to replace the exhaust cleaner.

To ascertain the degree of clogging of the filter separator operate as follows:

- 1) Install a pressure gauge upstream of the separator and make sure that on the machine is efficient.
- 2) Start the machine.
- 3) Partially open the faucet flow until the pressure gauge on the control panel shows the value of the operating pressure.
- 4) Read the value of the pressure gauge located upstream of the oil separator filter and compare two values: if, between the two readings, is a difference of more than 1 bar replace the filter separator

The oil separator filter must never be washed with water.



**WARNING:** *Pressure vessel*

#### 13.4.16 REPLACEMENT OF THE OIL SEPARATOR FILTER

1. The operation must be undertaken with machine off and no pressure in the oil separator tank.
2. Disconnect all the pipes from the connections positioned on the closure flange of the separator tank, marking them so there is no problem on re-assembly.
3. Loosen the screws (fig. 13.4-7 part A) and remove the flange (B).



4. Extract the filtering element (D) together with the seals (C) and (E).
5. Assemble the new seal (E) in the relative slot which has been previously cleaned. Endure that a metallic insert has been clipped to the seal in order to avoid the isolation of the filter and the accumulation of static electricity. Otherwise there is a risk of the separator filter catching fire.
6. Insert the new separator element correctly positioning it into the relative slot.
7. Assemble the second seal (C) with the same precautions as above.
8. Reassemble the flange (B) in the pre-assembly position.
9. Tighten the bolts (A), with a tightening torque of 80 Nm.
10. Re-connect all the pipes to the respective fittings.
11. Start up the machine ensuring there is no leakage between the cap and the tank.
12. Allow the machine to operate for 10-15 minutes with closed cocks
13. Stop the machine with tank depressurized to 0 bar, re-check the screw tightening (A).

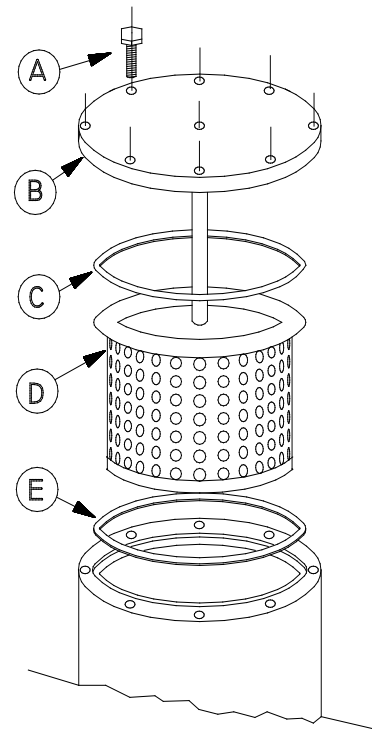



Figure 13.4-7 Oil separator filter

**WARNING:** *Pressure vessel***13.4.17 ENGINE CONTROL AND MAINTENANCE**

As for the controls of the engine and replacing air filters, diesel filter, timing belt, motor oil and other specific controls refer to the owner's manual of the engine manufacturer attached to this documentation.



	<b>USER'S AND MAINTENANCE MANUAL</b>	Date:	09/04/2024
		Code	MAN D300T4F ENG
<b>Motor compressor : D300T4F</b>		Revision	06

## 14 SPARE PARTS



In case of need to order a single component contact your authorized service center ELGI.



	<b>USER'S AND MAINTENANCE MANUAL</b>	Date:	09/04/2024
		Code	MAN D300T4F ENG
<b>Motor compressor : D300T4F</b>		Revision	06

## 15 FAULTS AND TROUBLESHOOTING

Abnormal	Cause	Solution
The engine will not start.	Battery discharged or defective.	Recharge and replace if necessary.
	Terminals of the battery cables oxidized or loose.	Cleaning of the same and their tightening.
	No fuel.	Top up the fuel in the diesel tank.
	Solenoid faulty fuel.	Seek customer service by the manufacturer of the engine.
	Air in the fuel pipe.	Locate the infiltration by careful verification of all pipes.
	Injection pump defective.	Call in Customer Service by the engine manufacturer.
	Temperature sensors defective.	They are located at: - Headed-cylinder engine; - Output air compressor; - Tank separator. One at a time, unplug its power cable from the probes to identify the defective sensor and replace it. The temperature light on the control panel should go off.
Opening the taps the motor does not accelerate.	Starter defective Injectors failures	Call in Customer Service by the engine manufacturer.
	Control valve of maximum pressure defective.	Remove the control valve max and accurately control the spring and the conical seat. If the defect cannot be repaired, the valve must be replaced.
The engine speeds up but no air come out	Minimum pressure control valve blocked.	Disassemble and check that the piston is free to move. Check that the spring is intact. If the defect cannot be repaired the valve must be replaced. Reassemble and adjust the minimum pressure following the instructions in Section 11.3.

The machine stops suddenly and can only be restarted after a few minutes of waiting.

A temperature sensor detects a temperature anomaly and consequently stops the machine.

Take off one at a time, locate the probe that determines the stop. If that proves to be placed on the engine, check the oil level of the motor, the voltage and the conditions of the alternator belt. For water-cooled engines, check the coolant level.  
If it turned out to be the probe placed on the compressor control the level of 'oil in the tank and



	<b>USER'S AND MAINTENANCE MANUAL</b>	Date:	09/04/2024
		Code	MAN D300T4F ENG
<b>Motor compressor : D300T4F</b>		Revision	06

Abnormal	Cause	Solution
		if necessary top up; Check the cooling fan and clean the radiator; replace the oil filter of the compressor. If that proves to be positioned on the oil separator tank, check the oil separator filter following the instructions to Par. 13.4-15, proceeding to its eventual replacement Par 13.4-16.
Abnormal	Cause	Solution
The engine does not reach the maximum speed of the speed indicated and the compressor does not do.	The spring piston accelerator is broken or to be put under tension.	Check the tension of the spring piston accelerator (Par. 11.1.2).
	Engine speed lower than expected.	Have the injection apparatus of the motor by qualified personnel. Replace the fuel filter. Run the draining of the fuel tank (Par. 13.4.9).
Oil leaking from the taps.	Minimum working pressure too low.	Adjust it according to the instructions of Par. 11.3.
	Too much oil in the tank.	To the correct level (Par.13.4).
	The machine works in non-horizontal position.	Ensure position the machine level
	Nozzle clogged oil recovery.	See Par. 13.4.8.
	Defective exhaust cleaner.	See Par. 13.4.15.

	<b>USER'S AND MAINTENANCE MANUAL</b>	Date:	09/04/2024
		Code	MAN D300T4F ENG
<b>Motor compressor : D300T4F</b>		Revision	06

## 16 DISPOSAL, ELIMINATION, DISPOSAL OF THE MACHINE

### 16.1 Instructions for dismantling

To dismantle the machine safely, proceed as follows:

- 1) Place the machine in a wide and make sure it is turned off.
  - 2) Empty the liquid waste in the tanks of motor oil, fuel, coolant, hydraulic oil and store them in special containers. For disposal of these types of waste follow the next paragraph.
  - 3) Loosen the screws of the body and remove covers
  - 4) Remove all the components of the machine one by one dividing them according to their material composition
- The various components of the machine have to be disposed in relation to the type of waste to which they belong.

The following describes the different types of waste that can be generated during the life of the machine:

- Waste motor oil
- Waste hydraulic oil
- Residues of coolant
- Residual fuel
- Liquid remaining battery power
- Rags or paper impregnated with a diluents or other substances used for the cleaning of the various organs of the machine

## 17 ELIMINATING THE MACHINE

The operations of destruction and disposal must be carried out in a safe condition by a qualified specialist and after carefully reading and incorporated the recommendations and instructions provided in this section of the manual of use and maintenance and consulting the safety data sheets relating to substances in the machine mentioned in the previous chapter..

Once you reach the end of the mechanical life of the compressor, this has to be taken out of service so that it cannot be used for other purposes.



## 18 WASTE MANAGEMENT



The withdrawal of special waste and / or hazardous should be entrusted with the written contract to authorized firms; and those who physically transport and handling must be in possession of the required authorizations. The hauliers authorized must be enrolled in the relevant register.

### 18.1 Special waste

They are considered a hazardous waste residue from industrial, agricultural, crafts, commercial and service, for quality or quantity, is declared similar to municipal waste. These include also: machinery, equipment and metal parts of engines deteriorated and obsolete.



### 18.2 Toxic and hazardous waste



Are considered hazardous toxic waste all waste containing or contaminated by the substances listed in Directives 75/442 / CEE, 76/403 / CEE and 768/319 / CEE or other regulations in the countries of use and installation of the machines.



### 18.3 Temporary storage



Are considered hazardous toxic waste all waste containing or contaminated by substances listed in Directives 75/442 / CEE, 76/403 / CEE and 768/319 / CEE or other regulations in the countries of use and installation of the machines.

Temporary storage of toxic and hazardous waste is allowed according to the expected disposal of waste by treatment and / or final disposal. In any case, observe the mandatory laws of the country of the user in the field of environmental protection.

### 18.4 Features of the containers

The fixed and mobile containers, designed to contain toxic and hazardous waste must possess adequate strength requirements in relation to the chemical-physical properties and to its hazardous characteristics of the waste contained. The containers in which products are stored or dangerous or harmful materials must, in order to disclose the nature of their content, carry signs and markings prescribed.



### 18.5 Registration requirements

In accordance with the EU Directive 75/439 / CEE on the disposal of waste oil, the records of loading / unloading must be kept by all companies that produce hazardous waste or hazardous toxic from industrial and artisanal (in each case the 'Users should refer to the regulations implementing that Directive in the country of installation and use of the machines).



# PARTS LIST

## D 300T4F



4610 Entrance Drive St A - Charlotte, NC 28273

PHONE: 704-523-4123

E-MAIL: [Portableservice@elgi.com](mailto:Portableservice@elgi.com) - [Portablesales@elgi.com](mailto:Portablesales@elgi.com)

Copyright © 2014, ROTAIR S.P.A. - All rights reserved This manual is intellectual property of ROTAIR S.P.A. Its full or partial reproduction is forbidden under any form, on any support and by any means, without the written authorization by ROTAIR S.P.A.



### D300T4F - Dimensions

Tab. 01.0

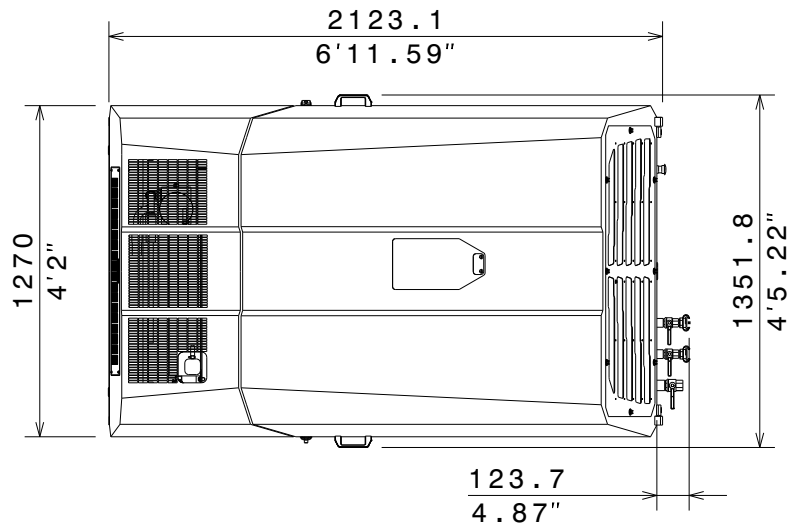
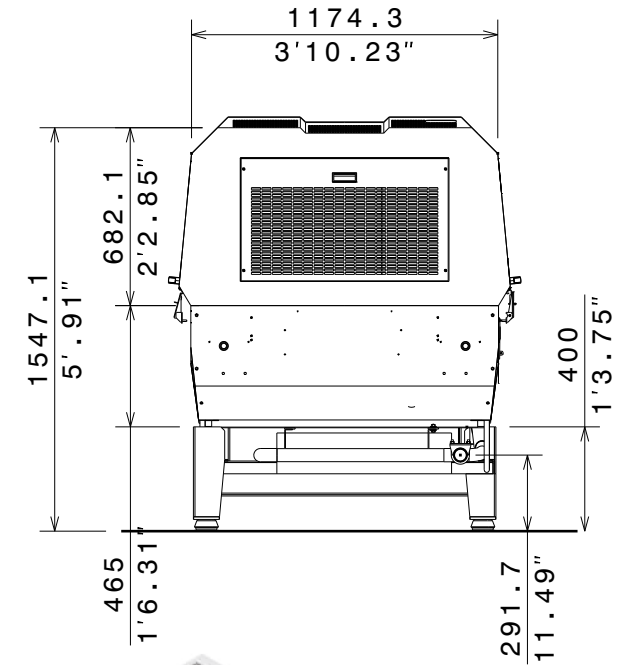
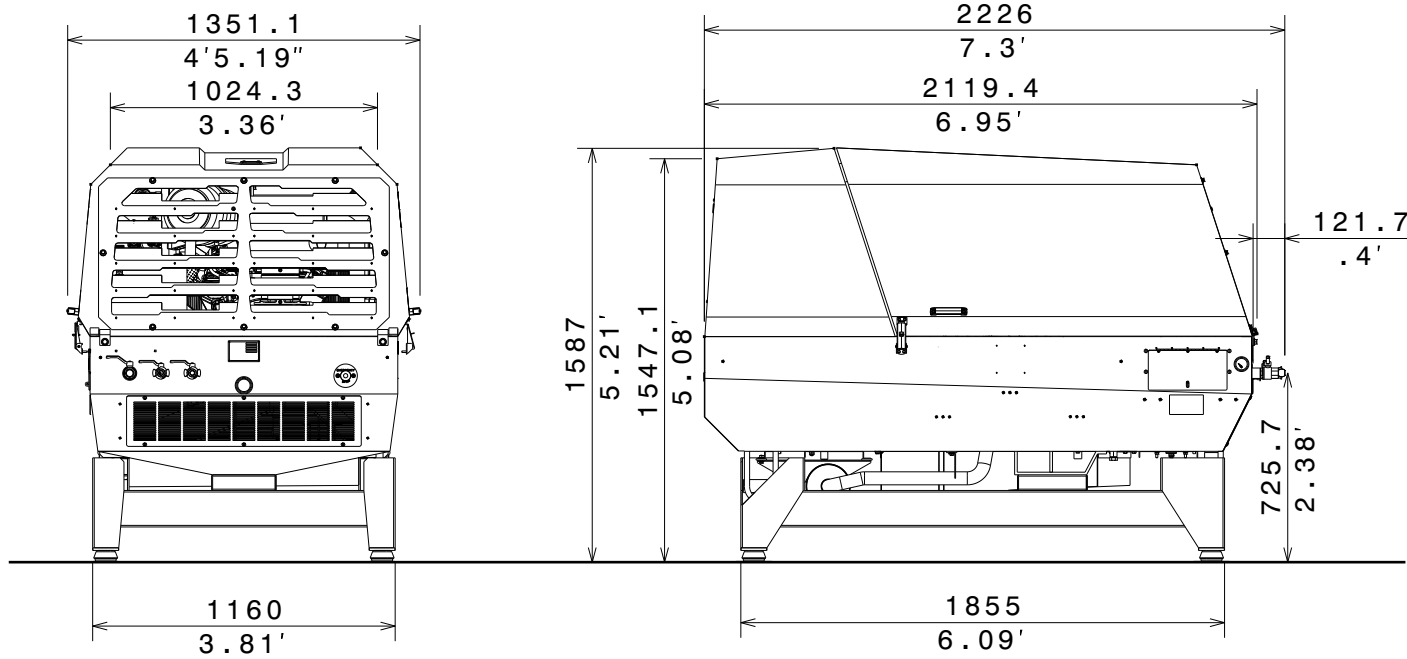

mm  
FEET / INCHES





# PARTS LIST

## Motocompressor – D300T4F

PARTS LEGENDA: Chassis

Tab. 01.0

REF	NAME	CODE	QUANTITY
1	Skid version with subframe	A	---

Detail B

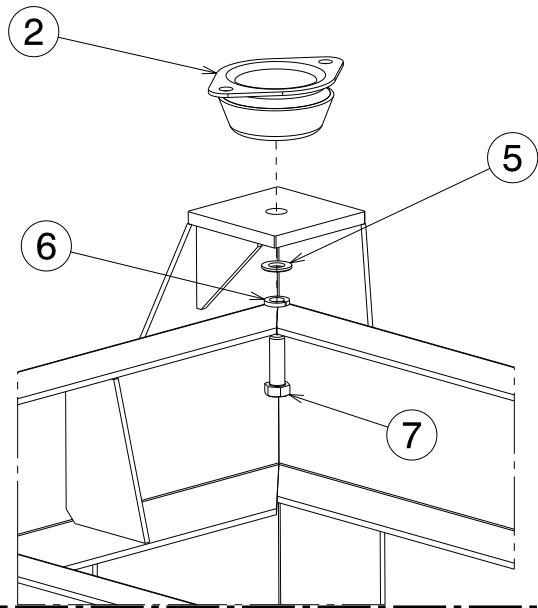

Detail A

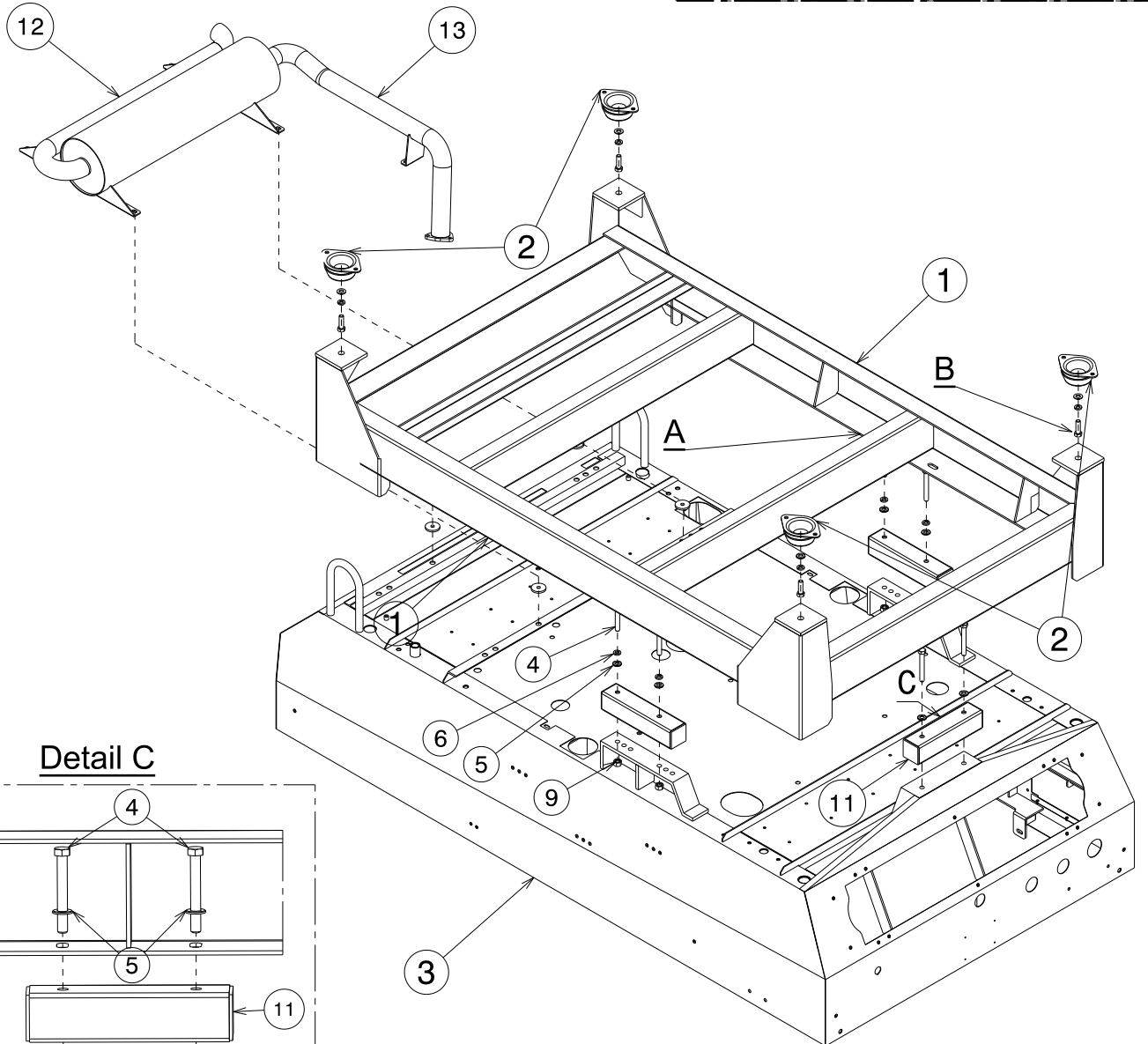
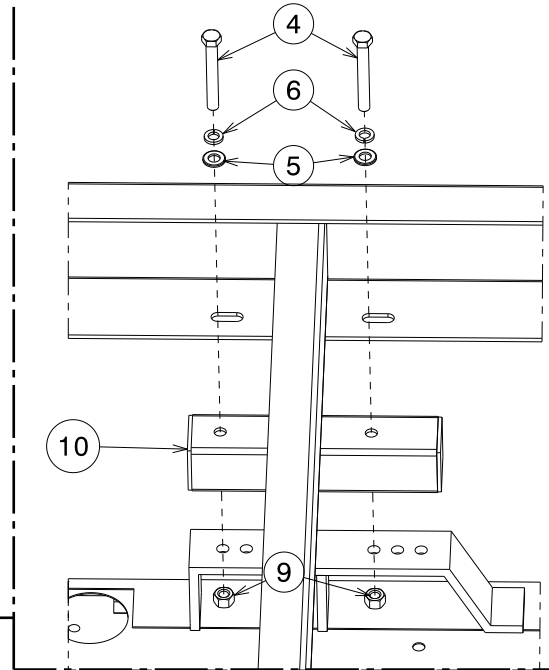

Detail C

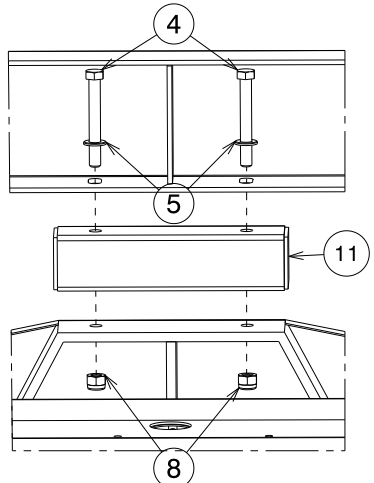



# PARTS LIST

## Motocompressor – D300T4F

PARTS LEGENDA: Skid Chassis

Tab. 01.1

REF	NAME	CODE	QUANTITY
1	Skid version chassis	038-10340020-S	1
2	Silent Block	061-0065-S	4
3	Chassis	038-10340-S	1
4	Hex head screw M12x95 screw	132-205-S	6
5	Flat washer d.13	015-034-S	10
6	Elastic washers	139-060-S	8
7	Hex head screw M12x40 screw	132-194-S	4
8	Self-locking nut M12	137-060-S	2
9	Hex nut M12 UNI 5587	135-060-S	4
10	Axle-frame spacer (side)	009-318500-S	2
11	Axle-frame spacer (center)	009-318501-S	1
12	Muffler	042-0851830-S	1
13	Muffler collector	119-07450-S	1

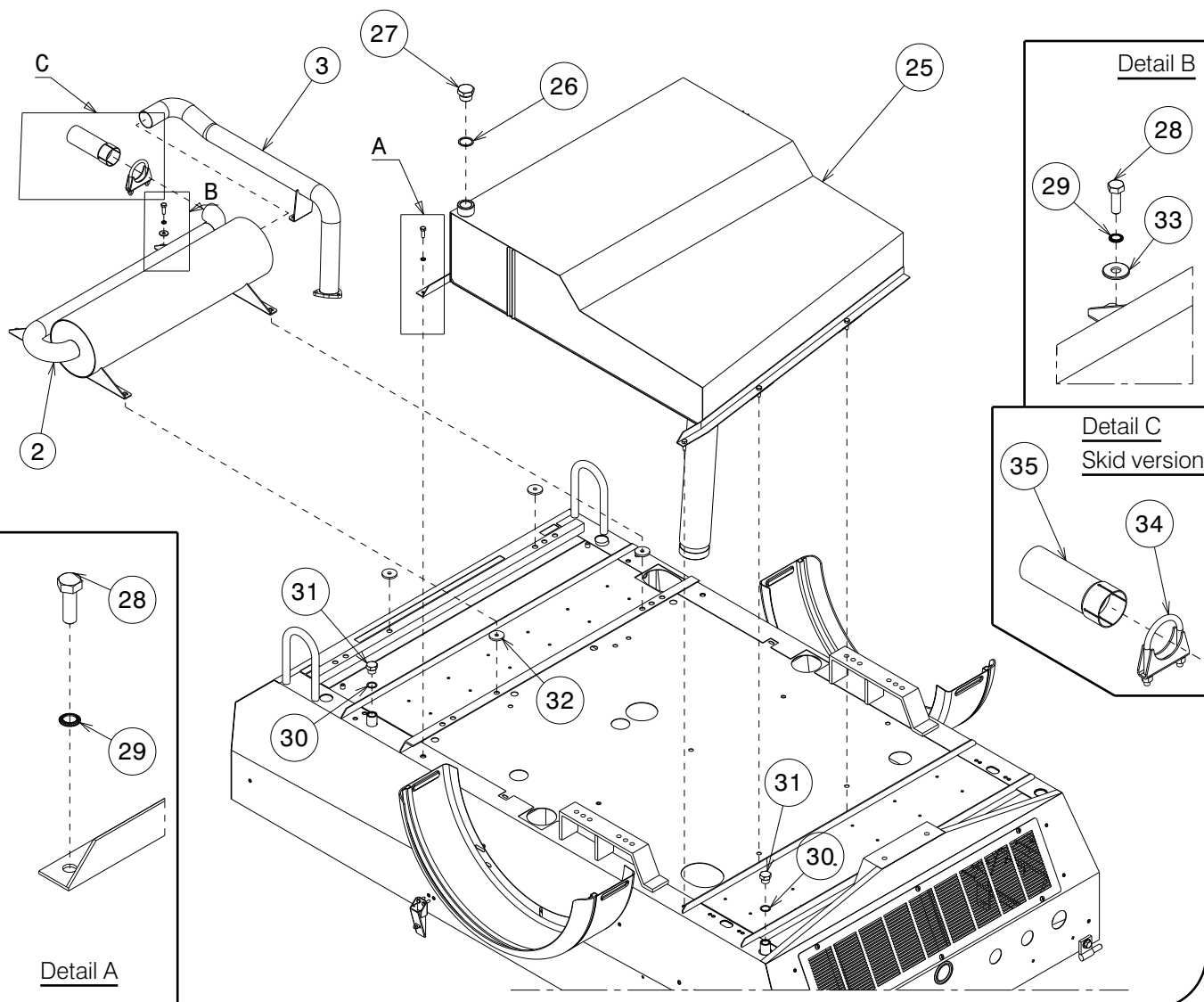
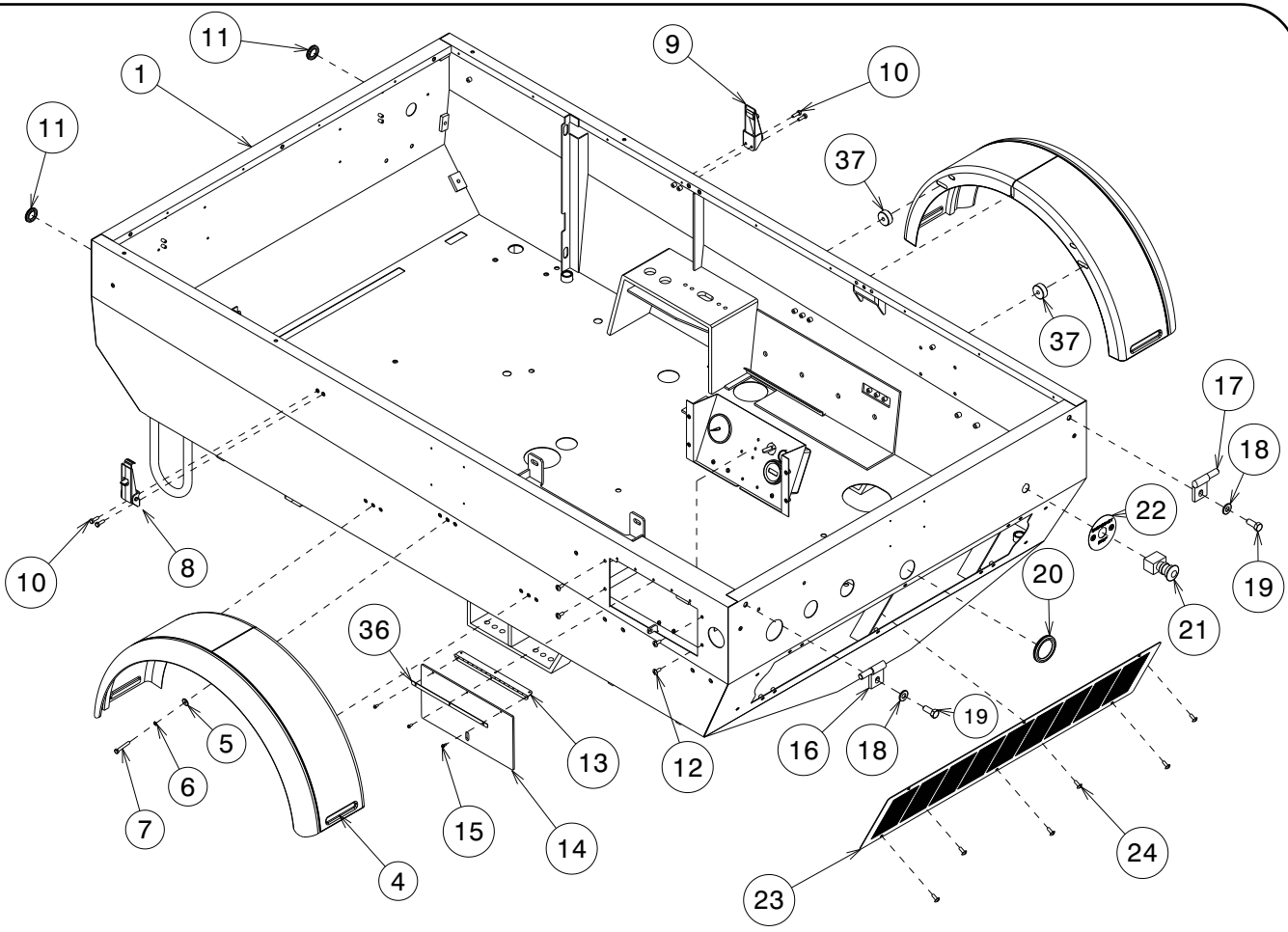

Detail A

Detail B

Detail C  
Skid version





# PARTS LIST

## Motocompressor – D300T4F

**PARTS LEGENDA:** Clampings to the frame

Tab. 01.2

REF	NAME		CODE	QUANTITY
1	Chassis		038-10340-S	1
2	Muffler		042-0851830-S	1
3	Muffler collector		119-07450-S	1
4	Mudguards		055-0154-S	2
5	Washer d. 6.6x18x2		015-029-S	6
6	Washer d.6		015-250-S	6
7	Hex head screw M6x40 UNI 5739		132-068-S	6
8	Lock without hole		128-006-S	1
9	Lock (possible with padlock)		128-0065-S	1
10	Hex head screw . M6x20		132-063-S	4
11	Diaphragm fairlead		239-021-S	2
12	Large head screw M6x16		243-009-S	4
13	Control panel hinge		007-029-S	1
14	Plexiglass door		057-0203-S	1
15	Large head screw 4x10		243-088-S	3
16	Right hinge		007-022-S	1
17	Left hinge		007-023-S	1
18	Flat washer d. 13		015-047-S	2
19	Hexagonal head screw M.12x30 UNI 5739		132-192-S	2
20	Diaphragm fairlead		239-048-S	1
21	Emergency button		154-066-S	1
22	"Emergency button" sticker		238-3113-S	1
23	Tropicalized air radiator closing panel		124-3010-S	1
24	Large head screw M6x16		243-009-S	6
25	Gasoil tank	Up to serial No. C39748	201-027332-S	1
	Gasoil tank	From serial No. C39749	201-02733201-S	1
26	Copper washer ( 1" )		015-018-S	1
27	Iron plug ( 1" )		106-135-S	1
28	Hex head screw M8x25 UNI 5739		132-102-S	11
29	Schnorr washer d.8		015-251-S	11
30	Copper washer ( ½" )		015-012-S	2
31	Iron plug ( ½" )		106-125-S	2
32	Seal for muffler d.40 th..5		023-077-S	4
33	Flat washer 8x24x2 UNI6593		015-031-S	4
34	Pipes clamp d.54x8		149-070-S	1
35	Muffler extension (Skid version)		119-04957-S	1
36	Plexiglass hinge protection blade		120-219402-S	1
37	Spacer		009-312-S	4

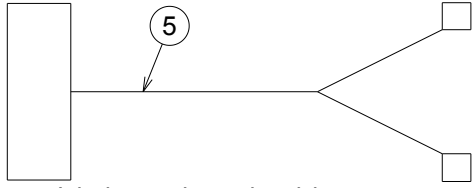

Lights electrical harness

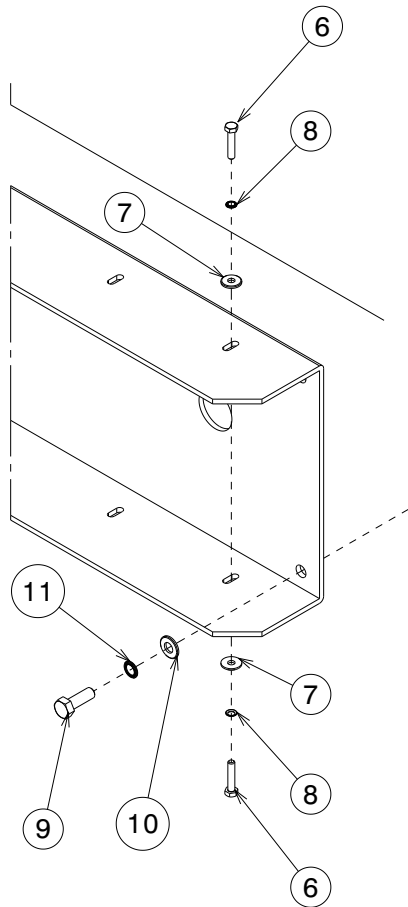

Detail A

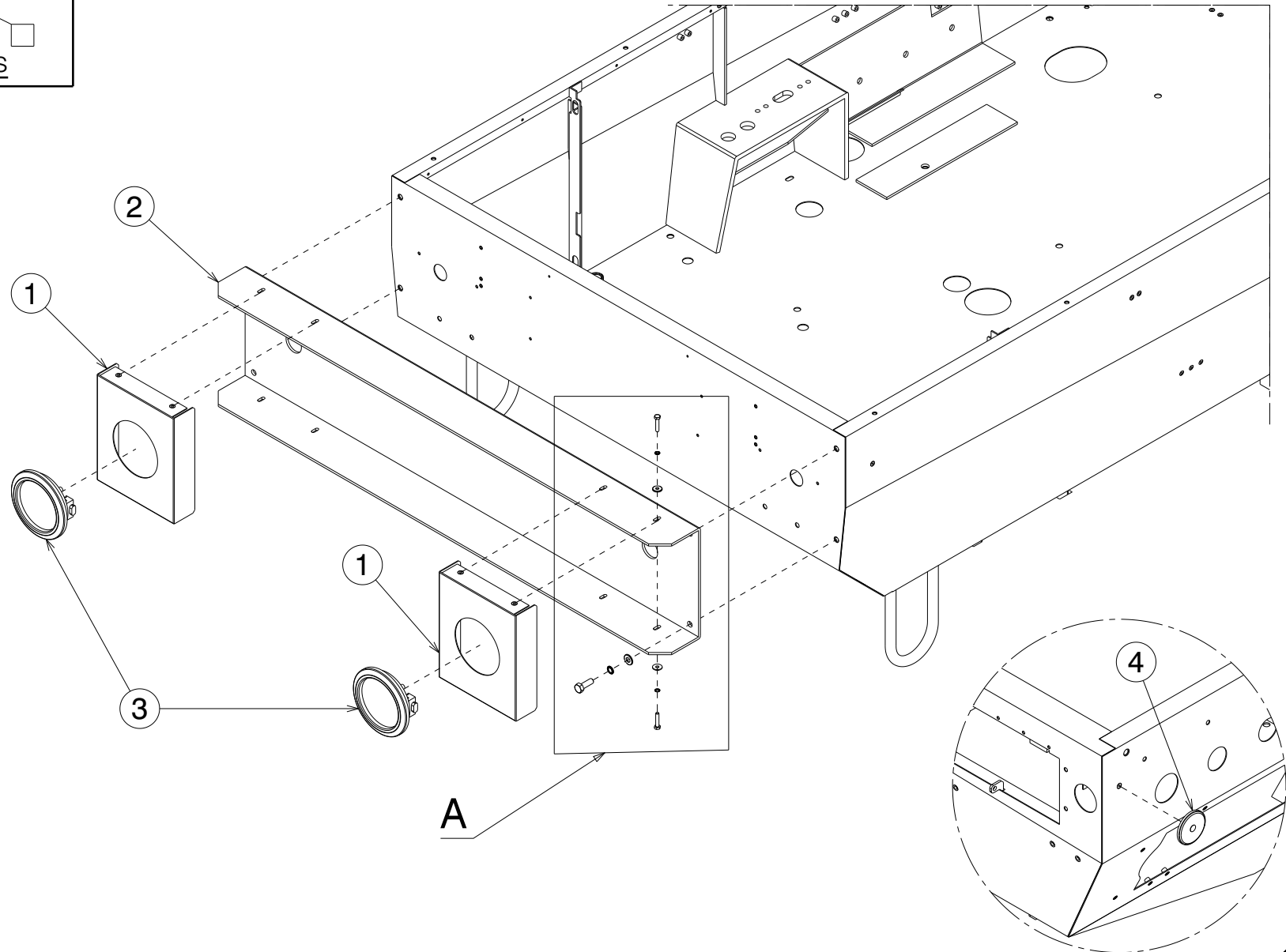



# PARTS LIST

## Motocompressor – D300T4F

PARTS LEGENDA: Bumper and lights Kit

Tab. 01.3

REF	NAME	CODE	QUANTITY
<b>BUMPER AND LIGHTS KIT: 240-07800048-S</b>			<b>1</b>
It includes:			
1	Lights support	010-113400-S	2
2	Bumper	032-11450-S	1
3	USA Light	142-0850-S	2
4	White reflector d.60	147-071-S	2
5	Electrical harness	224-53900-S	1
6	Hexagonal head Screw M6x30 UNI 5739	132-066-S	8
7	Washer d. 6.6x18x2	015-029-S	8
8	Washer d.6	015-250-S	8
9	Hexagonal head screw M10x30 UNI 5739	132-143-S	4
10	Flat washer 10,2x21x2	015-032-S	4
11	Schnorr washer d.10	015-252-S	4





# PARTS LIST

## Motocompressor – D300T4F

PARTS LEGENDA: Radiator - Fancover

Tab. 02.1

REF	NAME	CODE	QUANTITY
1	Radiator	011-09650-S	1
2	Radiator support	049-02080-S	1
3	Fan cover closing panel	124-300-S	1
4	Hex head screw . M6x20	132-063-S	12
5	Fancover	001-153600-S	1
6	Fairlead	239-016-S	1
7	Right fan protection grid	124-267522-S	1
8	Left fan protection grid	124-267524-S	1
9	Upper fan protection grid	124-267520-S	1
10	Expansion tank	201-018150-S	1
11	Expansion tank support	010-34500-S	1
12	Hex head screw . M8x20 UNI 5739	132-101-S	8
13	Schnorr washer d.8	015-251-S	6
14	Flat washer 8x24x2 UNI6593	015-031-S	22
15	Self locking nut M8 UNI 7473	137-040-S	6
16	Flat washer 6x24x2 UNI6593	015-038-S	16
17	Washer d.6	015-250-S	18
18	Cable fastener clamp	149-220-S	1

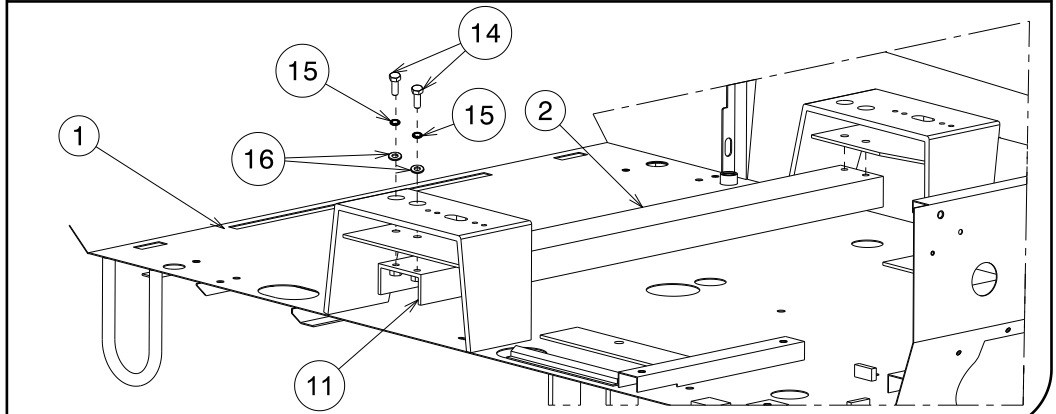
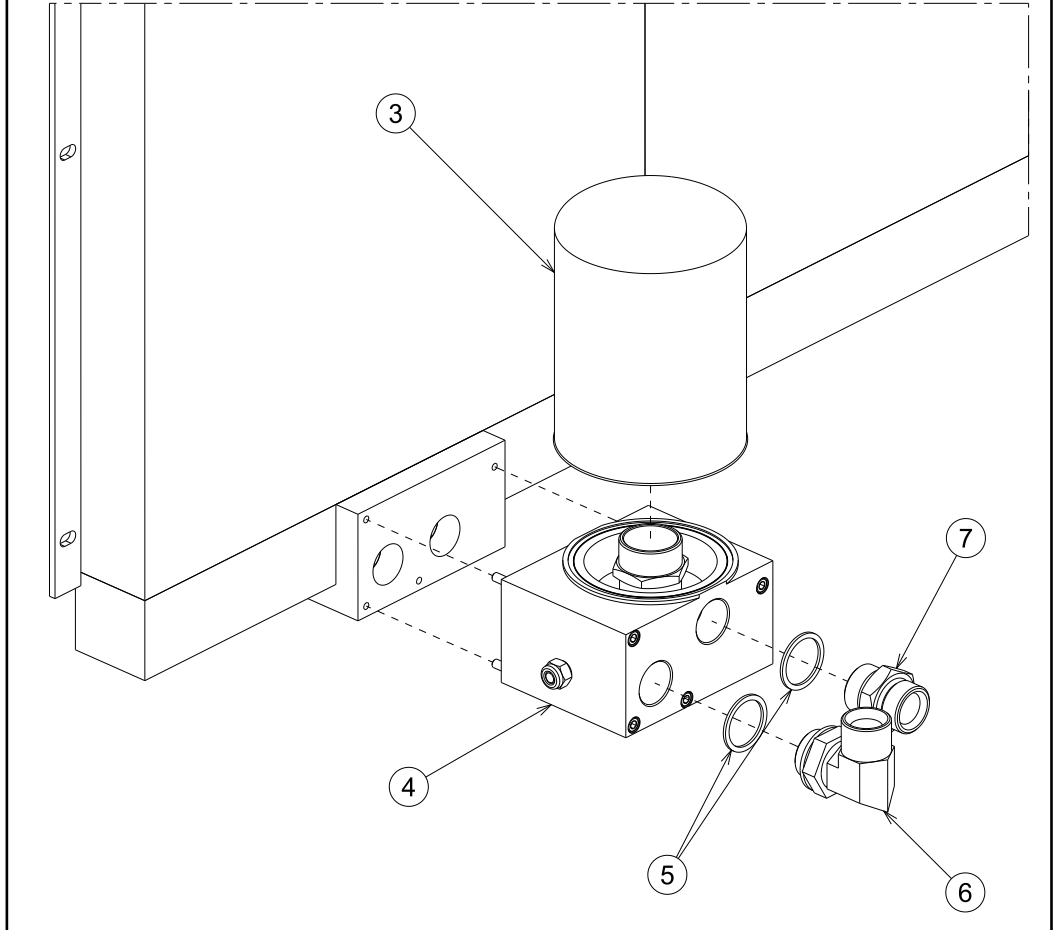
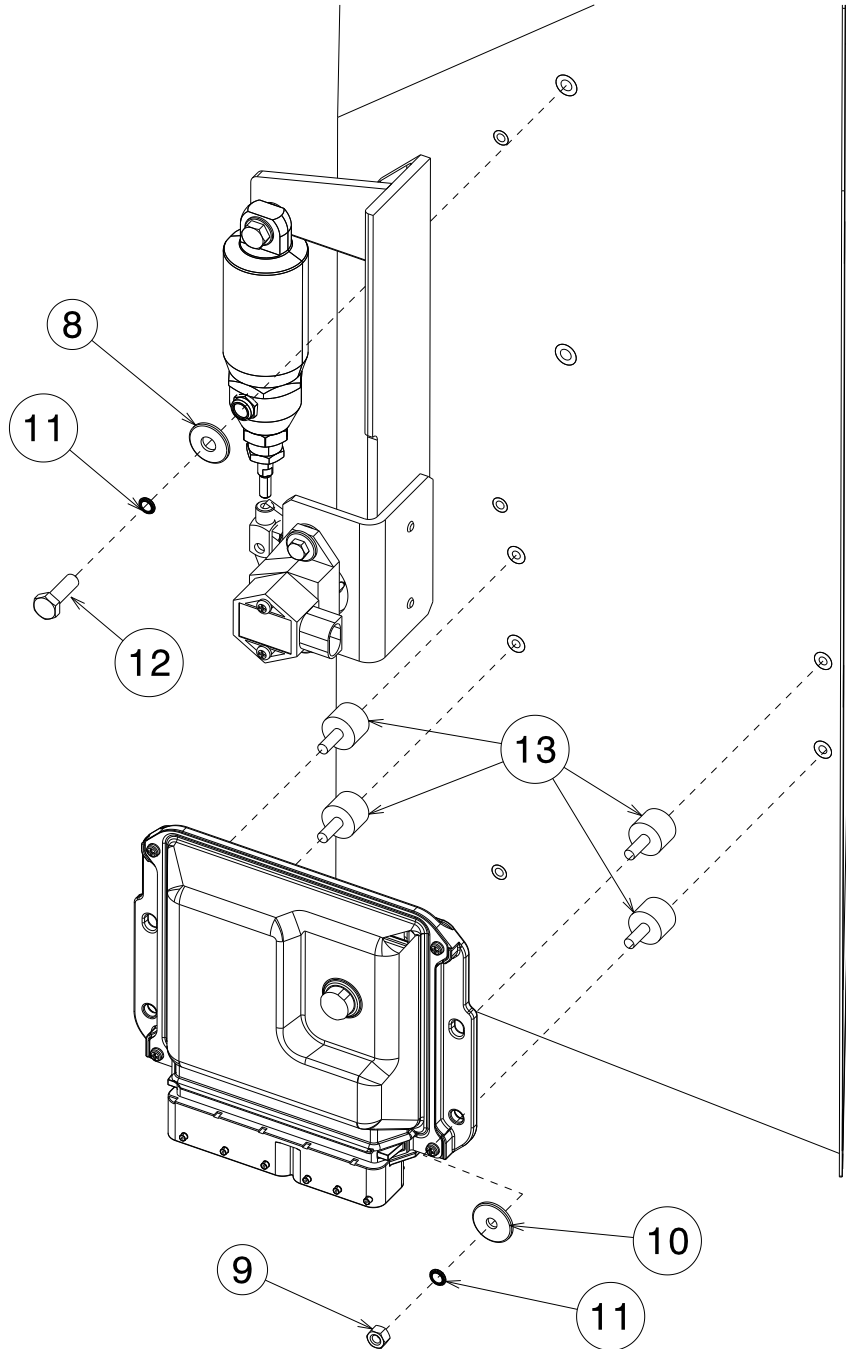



# PARTS LIST

## Motocompressor – D300T4F

PARTS LEGENDA: Radiator - Fancover

Tab. 02.2

REF	NAME	CODE	QUANTITY
1	Chassis	038-10340-S	1
2	Chassis reinforcement plate	208-3133-S	1
3	Oil filter	099-009-S	1
4	By-pass valve assembly	024-01152-F	1
5	Copper washer ( 1" )	015-018-S	2
6	90° fitting M+M ( 1" )	148-2987-S	1
7	Double screw ( 1" )	187-070-S	1
8	Flat washer 8x24x2 UNI6593	015-031-S	4
9	Hex nut M6 UNI 5587	135-030-S	4
10	Flat washer 6x24x2 UNI6593	015-038-S	4
11	Washer d.6	015-250-S	4
12	Hex head screw M8x25 UNI 5739	132-102-S	4
13	Silent block	061-019800-S	4
14	Hexagonal head screw M10x30 UNI 5739	132-143-S	4
15	Schnorr washer d.10	015-252-S	4
16	Flat washer 10,2x21x2	015-032-S	4

Tab. 03

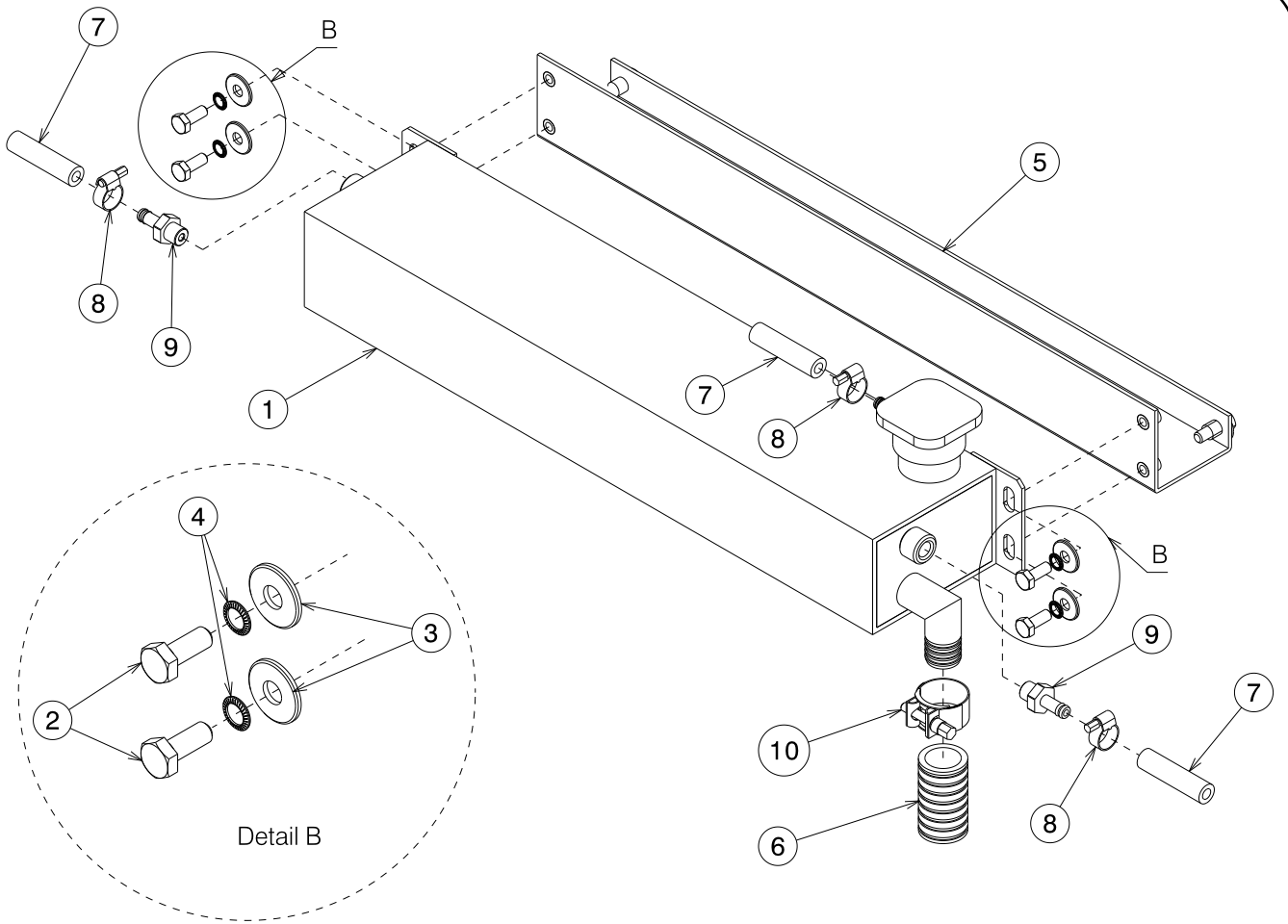

D300T4F - By-pass block - Expansion tank

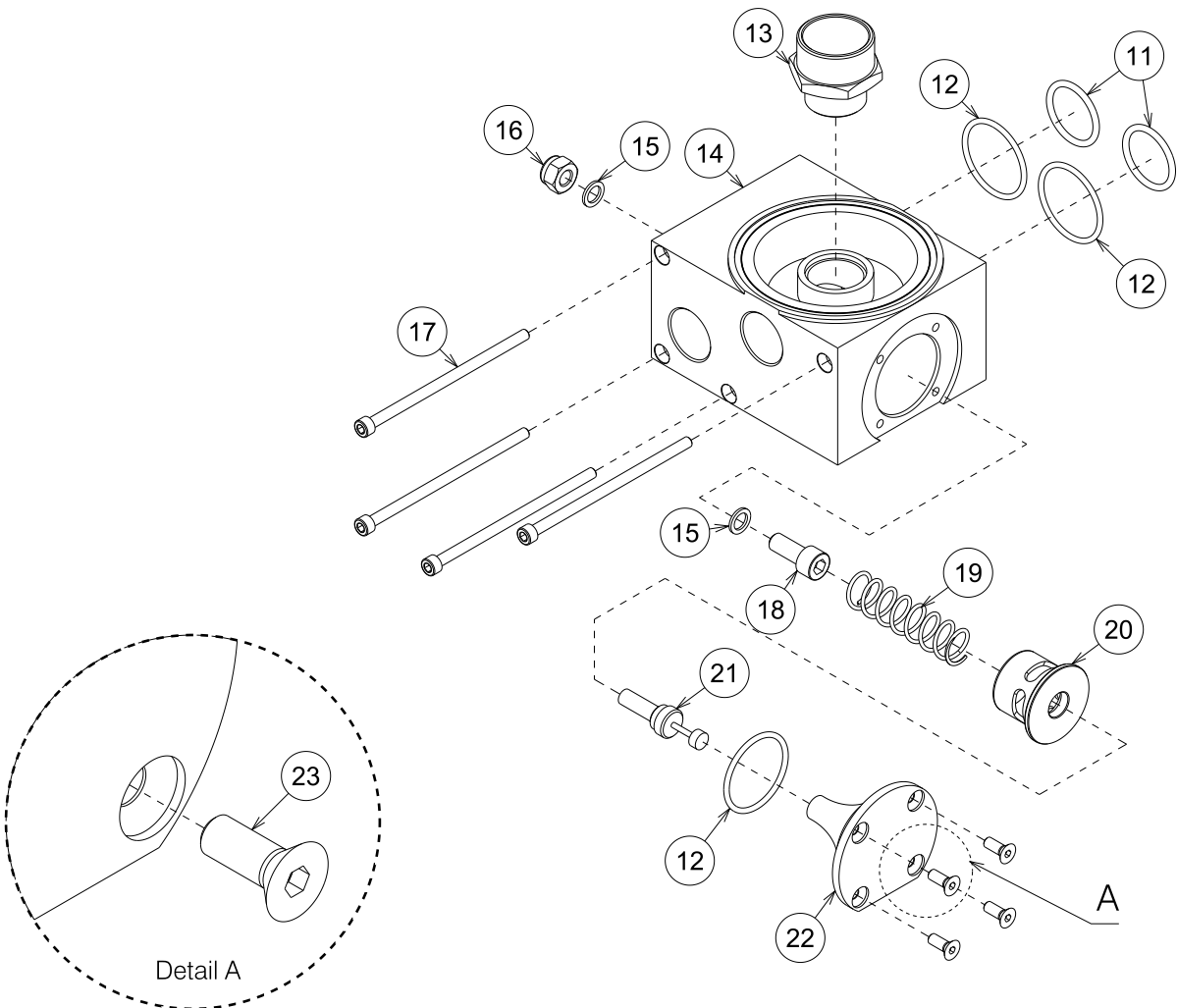

**ELGI**



# PARTS LIST

## Motocompressor – D300T4F

PARTS LEGENDA: D300T4F - By-pass block - Expansion tank

Tab. 03

REF	NAME	CODE	QUANTITY
1	Expansion tank	201-018150-S	1
2	Hex head screw . M8x20 UNI 5739	132-101-S	4
3	Flat washer 8x24x2 UNI6593	015-031-S	4
4	Schnorr washer d.8	015-251-S	4
5	Expansion tank support	010-34500-S	1
6	Pipe d. 25x34	089-009.5-S	1
7	Anti-oil pipe for fuel 15x8	089-120-S	3
8	Pipe clamp 10x16	149-007-S	3
9	M fitting ( 1/4" ) d.8	148-198.2-S	2
10	Pipe clamp	149-305-S	1
11	OR seal	023-0281-S	2
12	OR seal	023-1162-S	3
13	Double screw	187-003-S	1
14	By-pass big body	053-05662-S	1
15	Copper washer ( 1/8" )	015-005-S	2
16	Self-locking nut M10	137-050-S	1
17	Hex socket head cap screw M6x120	133-120-S	4
18	Hex socket head cap screw M10x25	133-182-S	1
19	Spring	043-053-S	1
20	Big by-pass valve spacer	009-1495-S	1
21	By-pass thermostat	103-015-S	1
22	Plug for big by-pass valve	106-411-S	1
23	Screw T.S.E.I.M M6x16	146-092-S	4

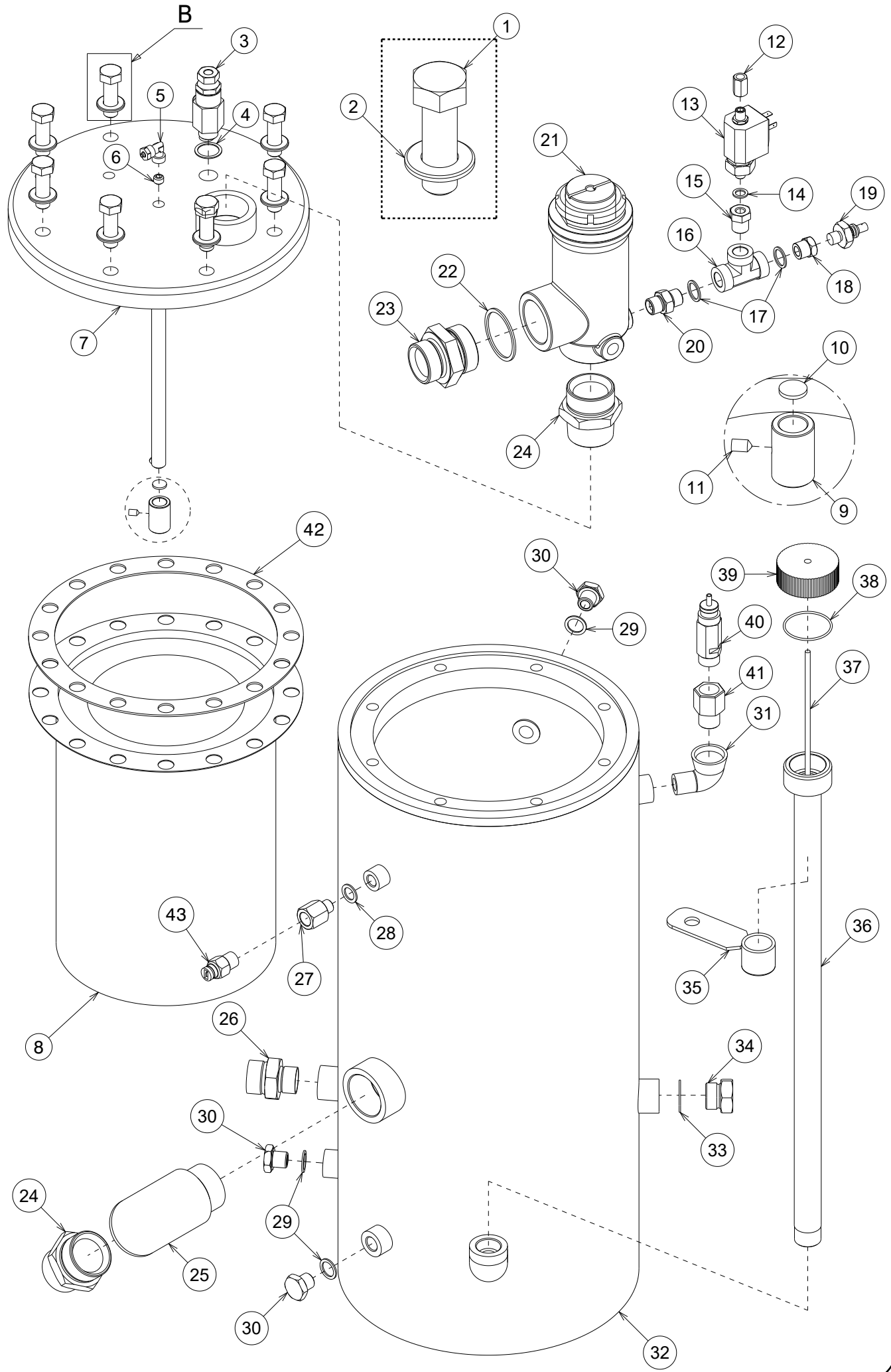



# PARTS LIST

## Motocompressor – D300T4F

PARTS LEGENDA: D300T4F – Separator tank

Tab. 04

REF	NAME	CODE	QUANTITY
1	Hexagonal head screw M14x35x1,5 UNI 5739	132-2435-S	8
2	Washer Diam. 15 x 28 x 2,5	015-036-S	8
3	Pressure regulation valve	024-032.1-F	1
4	Copper washer ( 1/2" )	015-012-S	1
5	Fitting 90' ( 1/4" ) for pipe d. 6	148-090-S	1
6	S.T screw ( 1/8" )	218-001-S	1
7	Separator tank closing flange	004-0635-S	1
8	Separator filter	157-1462-S	1
9	Oil filter support bush	223-506-S	1
10	Filter d.14x2	099-225-S	1
11	S.T screw M.6x10	218-1405-S	1
12	Spacer 20 D. 1/8"	009-014-S	1
13	Solenoid valve D.1/8 12V	160-052-S	1
14	Copper washer ( 1/8" )	015-005-S	1
15	Reduction 3/8"M to 1/8"F	190-021-S	1
16	T Fitting ( 3/8" )	148-282.5-S	1
17	Copper washer d.int. 17x22x1.5 (3/8")	015-010-S	2
18	Reduction M12x1.75 female to 3/8"M	190-027-S	1
19	Oil pressure switch 1,4bar	154-030-S	1
20	Double screw 3/8" cil a 3/8" conical	187-0252-S	1
21	Minimum pressure valve assembly	024-03111-F	1
22	Copper washer ( 1 1/2" )	015-019.1-S	1
23	Double screw ( 1 1/4" a 1 1/2" )	187-094-S	1
24	Double screw con+cil ( 1 1/2" )	187-0906-S	2
25	Short radius elbow M+F ( 1 1/2" )	111-061-S	1
26	Double screw ( 3/4" a 1" ) foro 19.1	187-065-S	1
27	Extension 16x1.5F – 1/4 M L=34	189-350-S	1
28	Copper washer ( 1/4" )	015-007-S	1
29	Copper washer ( d. 16.2x22x1.5 )	015-009-S	3
30	Iron plug ( M16x1.5 )	106-100-S	3
31	Short radius elbow M 1/2 + F 1/2	111-035-S	1
32	Separator tank 43 lt ASME	037-0345-S	1
33	Copper washer ( 3/4" )	015-015-S	1
34	Iron plug ( 3/4" )	106-130-S	1
35	Clamping ring	214-004.5-S	1
36	Oil level check	059-029-S	1
37	Oil level rod	086-026-S	1
38	OR seal CC2-4175	023-047-S	1
39	Oil level rod plug	106-010-S	1
40	Safety valve ASME	033-059-S	1
41	Extension M+F 1/2" (for ASME tank)	189-007-S	1
42	Separator tank seal	023-0744-S	1
43	115' thermo contact	103-008-S	1

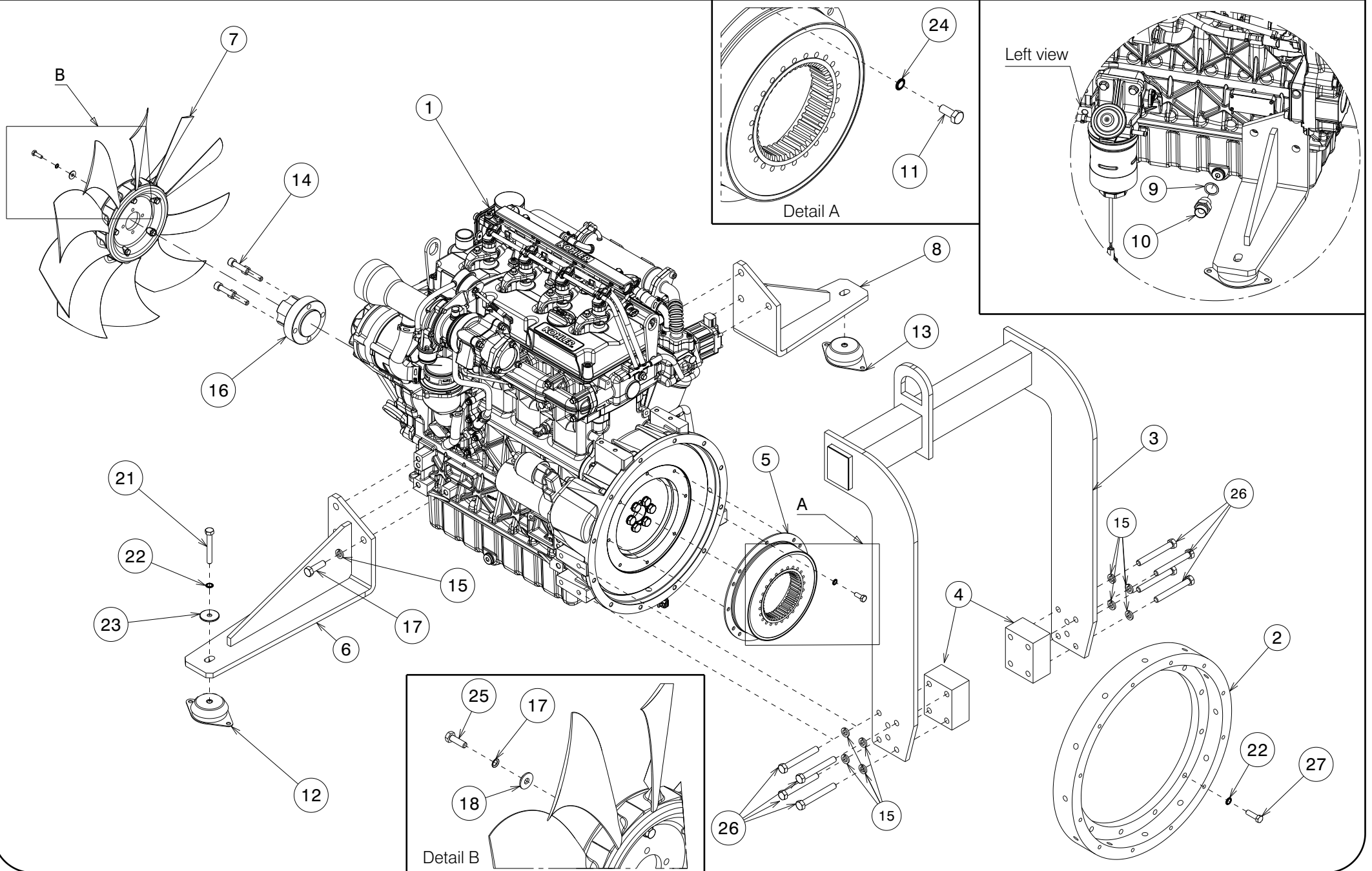



# PARTS LIST

## Motocompressor – D300T4F

PARTS LEGENDA: D300T4F – Engine

Tab. 05

FROM SERIAL NO. C43112			
REF	NAME	CODE	QUANTITY
1	Engine	165-4280-S	1
2	Fly-wheel housing	020-1010-S	1
3	Hoisting hook	017-0438220-S	1
4	Hoisting hook spacer	009-318550-S	2
5	KTR Engine joint	006-10811-S	1
6	R Engine support	039-112932-S	1
7	Fan	083-14143-S	1
8	L Engine support	039-112930-S	1
9	Copper washer ( 1/2" )	015-012-S	1
10	Double screw ( 1/2" – M22x1.5 )	187-014-S	1
11	Hex head screw 5/16-18	132-70180-S	8
12	Silent block	061-02375-S	1
13	Silent block	061-02470-S	1
14	Hex socket head cap screw M10x40 UNI 5931	133-185-S	4
15	Elastic washers d.12	139-060-S	14
16	Fan support	028-06561-S	1
17	Schnorr washer d.6	015-250-S	4
18	Flat washer d.6	015-029-S	4
19	Hexagonal head screw 3/8-16 UNC L=1"	132-701-S	12
20	Schnorr washer d.12	015-254-S	12
21	Hex head screw M10x75 UNI 5739	132-152-S	2
22	Schnorr washer d.10	015-252-S	14
23	Washer d. 10x40x2.5	015-037-S	2
24	Schnorr washer d.8	015-251-S	8
25	Hex head screw . M6x20	132-063-S	4
26	Hex head screw M12x95 screw	132-205-S	8
27	Hex head screw 3/8-16 UNC L=1"1/4	132-7012-S	12

FROM SERIAL NO. C45565			
REF	NAME	CODE	QUANTITY
7	Fan	083-141431-S	1
16	Fan support	028-06564-S	1
17	Schnorr washer d.8	015-251-S	4
18	Flat washer d.8	015-030-S	4
25	Hex head screw . M8x25	132-102-S	4

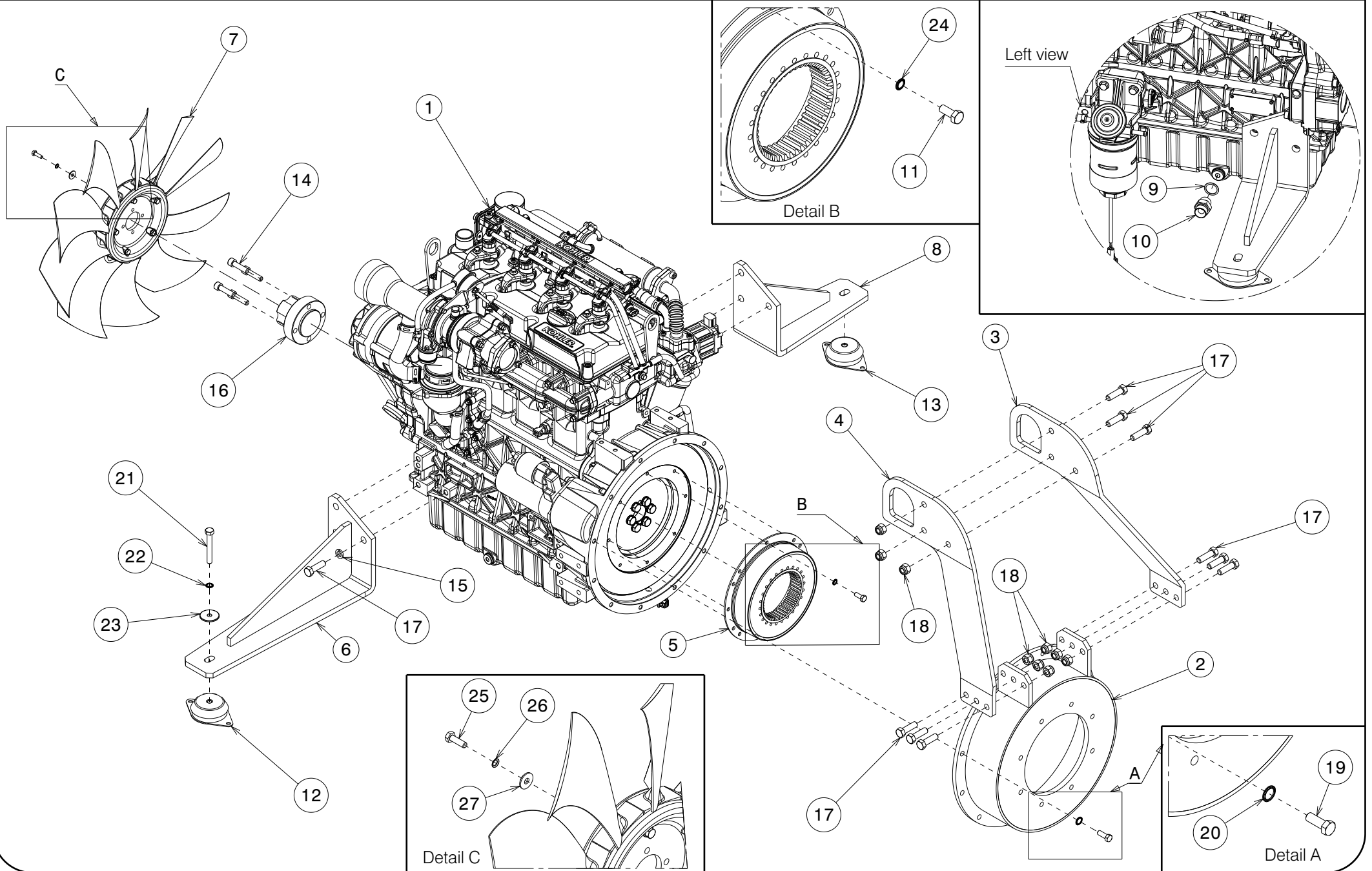



# PARTS LIST

## Motocompressor – D300T4F

PARTS LEGENDA: D300T4F – Engine

Tab. 05.1

UP TO SERIAL NO. C43111			
REF	NAME	CODE	QUANTITY
1	Engine	165-4280-S	1
2	Fly-wheel housing (Up to serial No.	020-10031-S	1
3	Left hoisting hook (Up to serial No.	017-0438015-S	1
4	Right hoisting hook (Up to serial No.	017-0438215-S	1
5	KTR Engine joint	006-10810-S	1
6	R Engine support	039-112932-S	1
7	Fan	083-14143-S	1
8	L Engine support	039-112930-S	1
9	Copper washer ( ½" )	015-012-S	1
10	Double screw ( ½" – M22x1.5 )	187-014-S	1
11	Hex head screw 5/16-18	132-70180-S	8
12	Silent block	061-0233-S	1
13	Silent block	061-0243-S	1
14	Hex socket head cap screw M10x40 UNI 5931	133-185-S	4
15	Elastic washers d.12	139-060-S	6
16	Fan support	028-06561-S	1
17	Hex head screw M12x40 screw	132-194-S	15
18	Self-locking nut M12	137-060-S	9
19	Hexagonal head screw 3/8-16 UNC L=1"	132-701-S	12
20	Schnorr washer d.12	015-254-S	12
21	Hex head screw M10x75 UNI 5739	132-152-S	2
22	Schnorr washer d.10	015-252-S	2
23	Washer d. 10x40x2.5	015-037-S	2
24	Schnorr washer d.8	015-251-S	8
25	Hex head screw . M6x20	132-063-S	4
26	Washer d.6	015-250-S	4
27	Washer d. 6.6x18x2	015-029-S	4

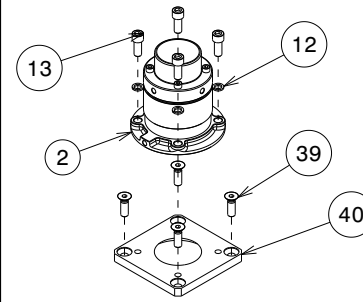
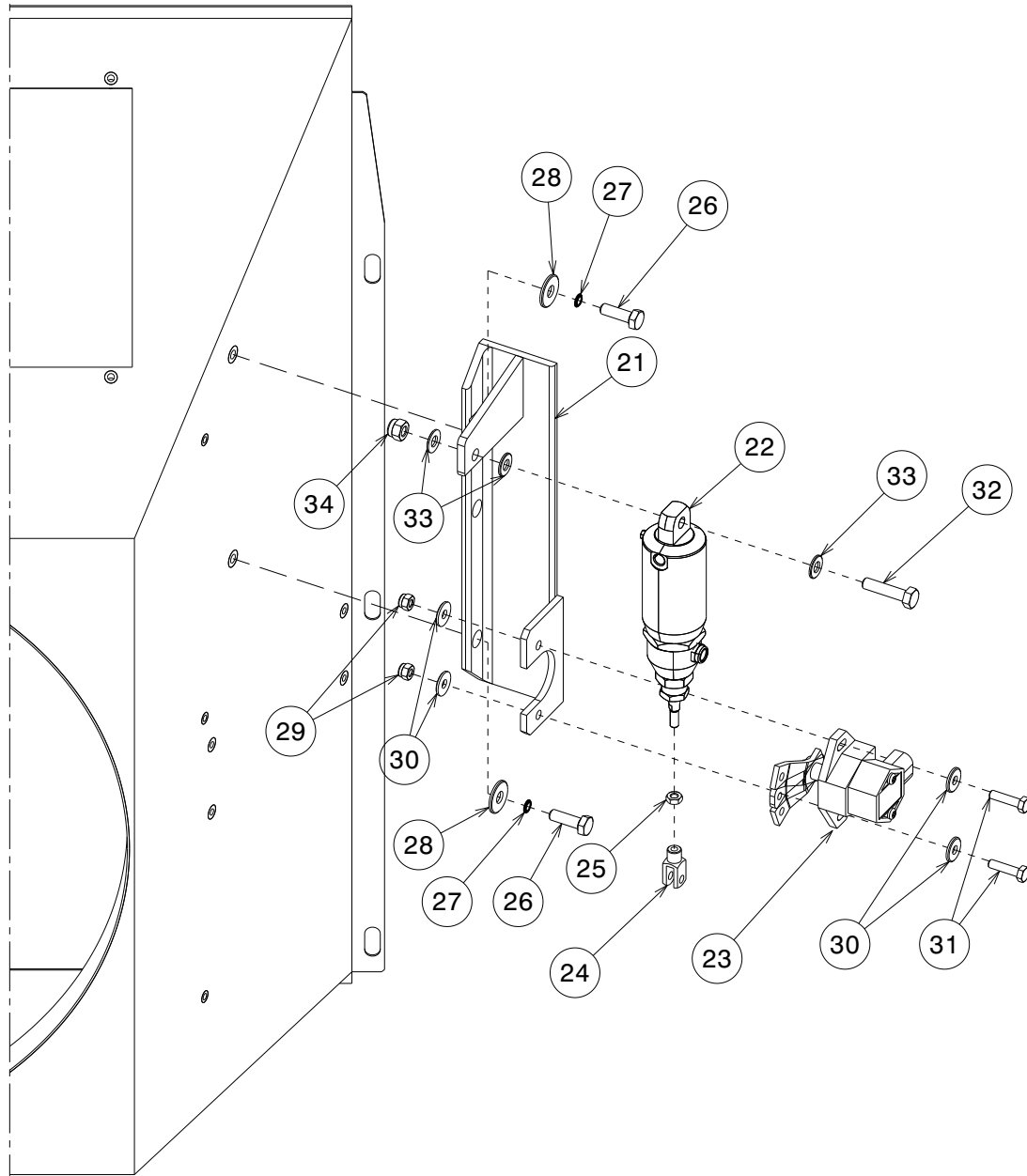

Up to Serial No.C42954

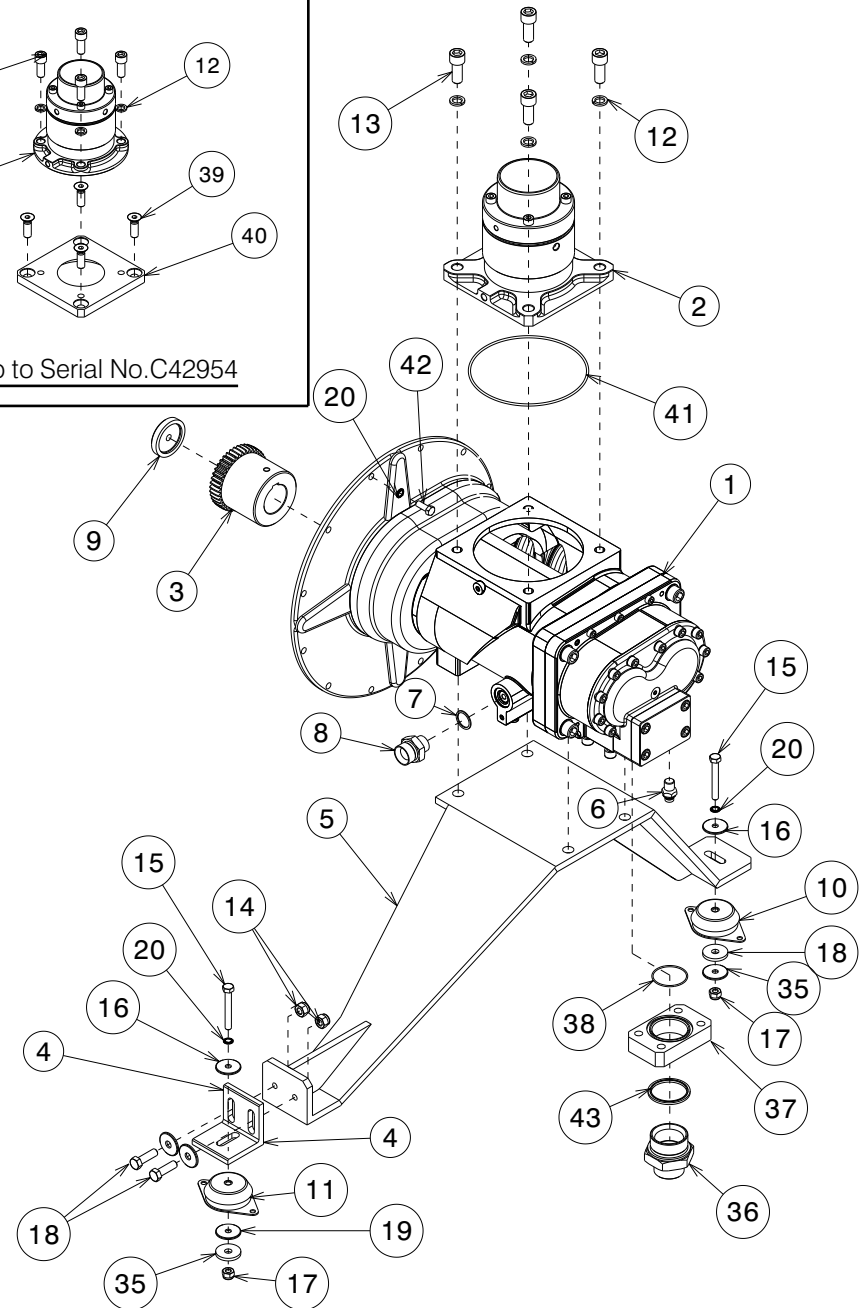



# PARTS LIST

## Motocompressor – D300T4F

PARTS LEGENDA: D300T4F – Air end – Acc.Piston

Tab. 05.2

FROM SERIAL No. C43112			
REF	NAME	CODE	QUANTITY
1	Air end assembly (From Serial No. C43112)	024-03291596-F	1
2	Regulator assembly (Up to Serial No. C42954)	024-130-F	1
	Regulator assembly (From Serial No. C42955)	024-1302-F	1
3	KTR Compressor joint	006-10813-S	1
4	"L" air end support	039-1153-S	1
5	Air end support	027-07755-S	1
6	Compressor thermo contact 125°	103-0125-S	1
7	Copper washer	015-013-S	1
8	Double screw 1" - 22x1,5	187-0730-S	1
9	Washer	015-090510-S	1
10	Silent block	061-02375-S	1
11	Silent block	061-02470-S	1
12	Elastic washers d. 16	139-080-S	4
13	Hex socket head cap screw M16x 35 (Up to Serial No. C42954)	133-332-S	4
	Hex socket head cap screw M16x 40 (From Serial No. C42955)	133-333-S	4
14	Self-locking nut M12	137-060-S	2
15	Hex head screw M10x75 UNI 5739	132-152-S	2
16	Flat washer d.10x40x2.5	015-037-S	2
17	Self-locking nut M10	137-050-S	2
18	Hex head screw M12x40	132-194-S	2
19	Flat washer d.12,5x40x3	015-0405-S	2
20	Schnorr washer d.10	015-252-S	14
21	Accelerator piston support	010-10950-S	1
22	Accelerator piston Kit	044-0040523-S	1
23	Accelerator signal transducer	205-0502-S	1
24	Accelerator piston fork	196-010-S	1
25	Hex nut M6 UNI 5589	135-031-S	1
26	Hex head screw M8x25 UNI 5739	132-102-S	2
27	Washer d.6	015-250-S	2
28	Flat washer 8x24x2 UNI6593	015-031-S	2
29	Hex nut M6 UNI 7473	137-030-S	2
30	Washer d. 6.6x18x2	015-029-S	2
31	Hex head screw screw M6x25 UNI 5739	132-065-S	2
32	Hexagonal head screw M8x30 UNI 5739	132-104-S	1
33	Flat washer 8,4x17x1,5 UNI 6592	015-030-S	1
34	Self locking nut M8 UNI 7473	137-040-S	1
35	Rubber washer	015-051-S	2
36	Double screw (2" – 2" ½)	187-100-S	1
37	Delivery clamping flange	004-047150-S	1
38	OR seal 3206	023-067-S	1
39	Hexagon socket countersunk head 16x35 UNI 5933	146-301-S	4
40	Flange	004-204250-S	1
41	OR seal 4725	023-065-S	1
42	Hexagonal head screw 3/8-16 unc l=1	132-701-S	12
43	Bonded washer	015-206-S	1

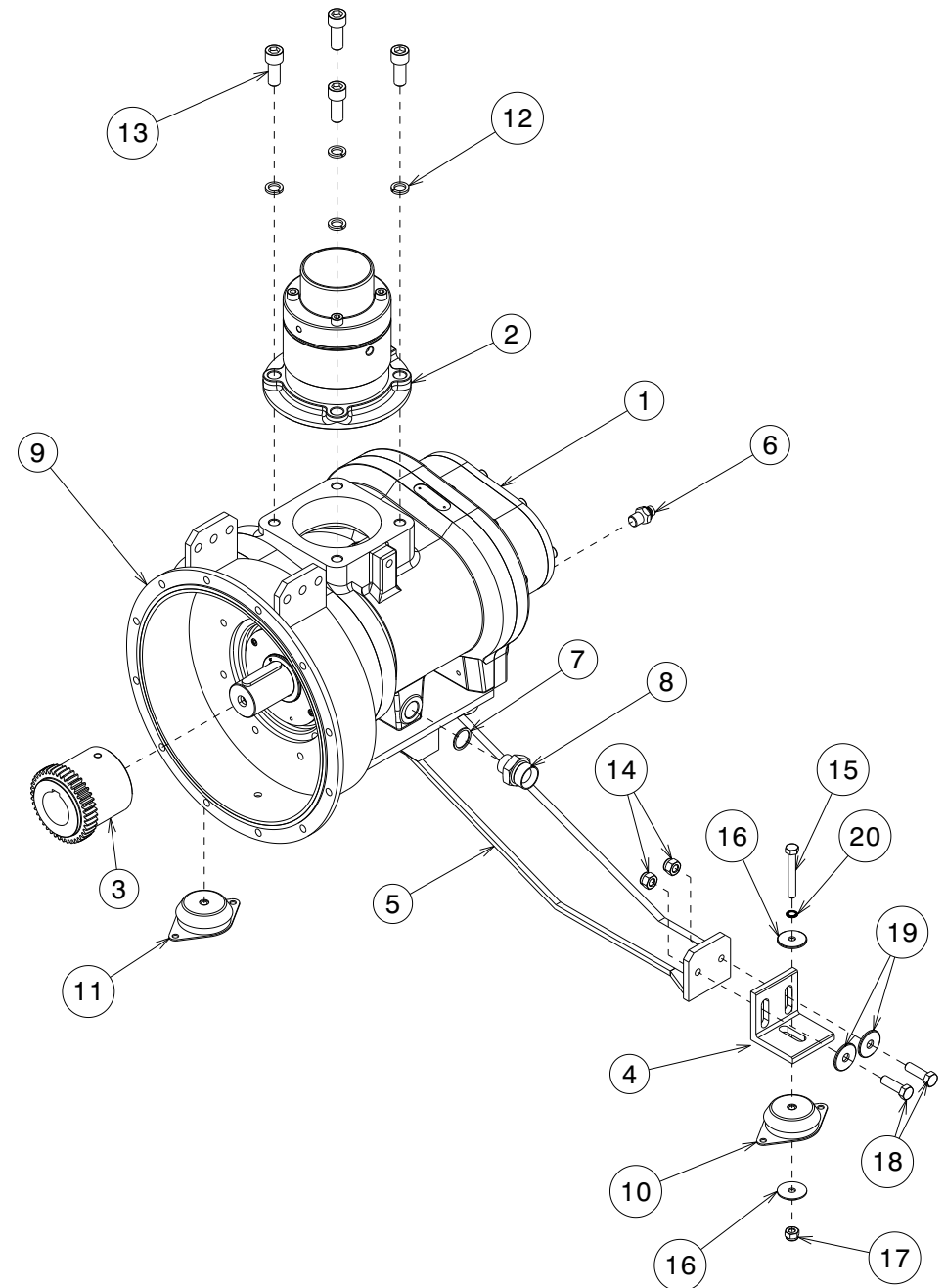
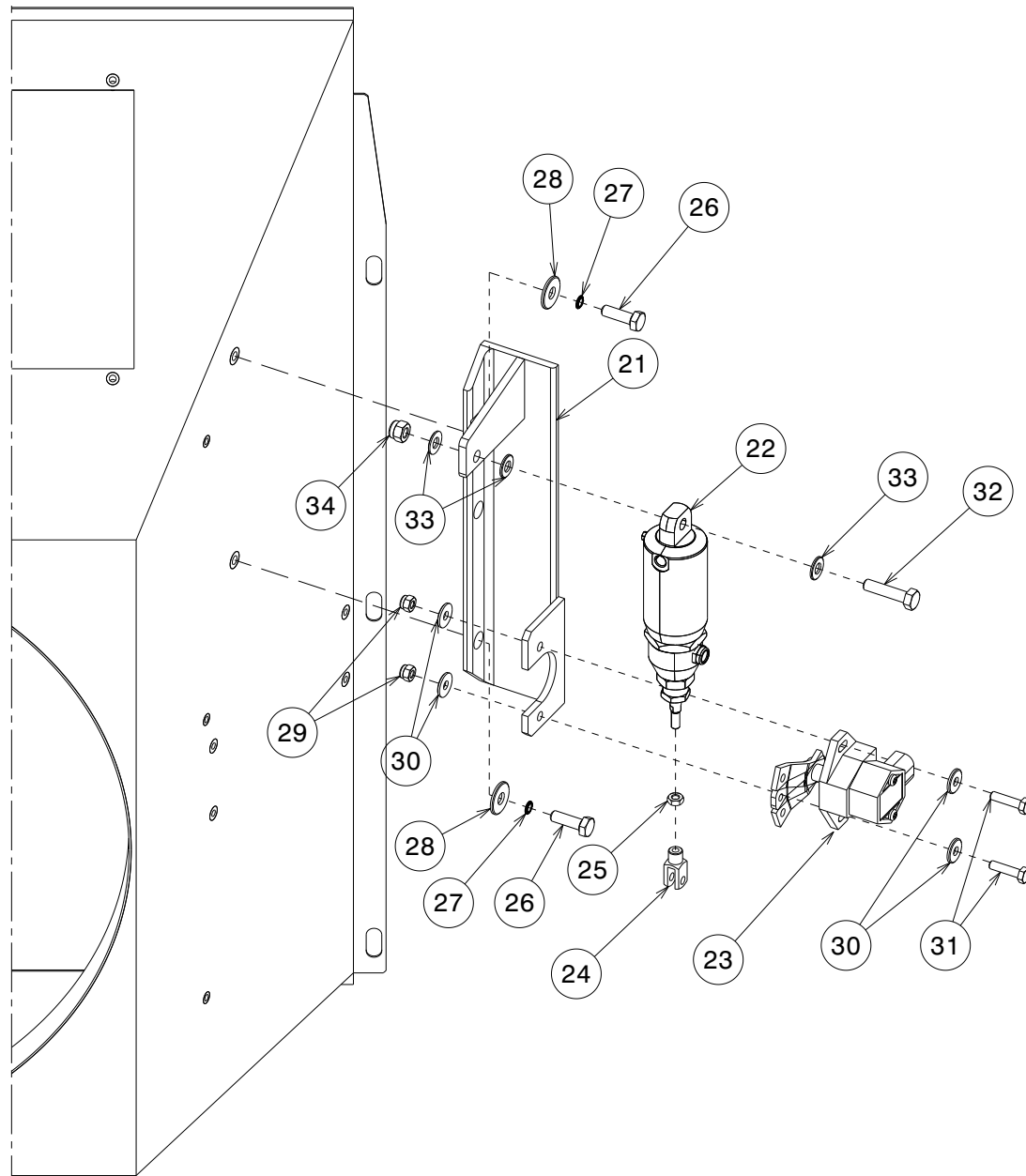



# PARTS LIST

## Motocompressor – D300T4F

PARTS LEGENDA: D300T4F – Air end – Acc.Piston

Tab. 05.2.1

UP TO SERIAL No. C43111			
REF	NAME	CODE	QUANTITY
1	Air end assembly	024-0971-F	1
2	Regulator assembly	024-130-F	1
3	KTR Compressor joint	006-10812-S	1
4	"L" air end support	039-1153-S	1
5	Air end support	027-07754-S	1
6	Compressor thermo contact 125°	103-0125-S	1
7	Copper washer ( 3/4" )	015-015-S	1
8	Double screw ( 3/4" a 1" ) foro 19.1	187-065-S	1
9	Fly-wheel housing	020-10031-S	1
10	Silent block	061-0233-S	1
11	Silent block	061-0243-S	1
12	Elastic washers d. 16	139-080-S	4
13	Hex socket head cap screw M16x 40	133-333-S	4
14	Self-locking nut M12	137-060-S	2
15	Hex head screw M10x75 UNI 5739	132-152-S	2
16	Flat washer d.10x40x2.5	015-037-S	2
17	Self-locking nut M10	137-050-S	2
18	Hex head screw M12x40	132-194-S	2
19	Flat washer d.12,5x40x3	015-0405-S	2
20	Schnorr washer d.10	015-252-S	2
21	Accelerator piston support	010-10950-S	1
22	Accelerator piston Kit	044-0040523-S	1
23	Accelerator signal transducer	205-0502-S	1
24	Accelerator piston fork	196-010-S	1
25	Hex nut M6 UNI 5589	135-031-S	1
26	Hex head screw M8x25 UNI 5739	132-102-S	2
27	Washer d.6	015-250-S	2
28	Flat washer 8x24x2 UNI6593	015-031-S	2
29	Hex nut M6 UNI 7473	137-030-S	2
30	Washer d. 6.6x18x2	015-029-S	2
31	Hex head screw screw M6x25 UNI 5739	132-065-S	2
32	Hexagonal head screw M8x30 UNI 5739	132-104-S	1
33	Flat washer 8,4x17x1,5 UNI 6592	015-030-S	1
34	Self locking nut M8 UNI 7473	137-040-S	1

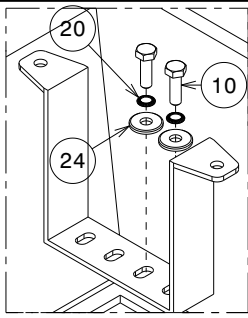

Detail A

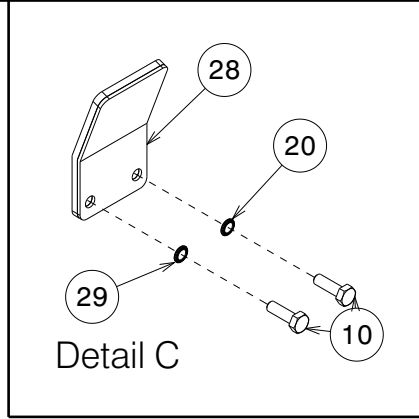

Detail C

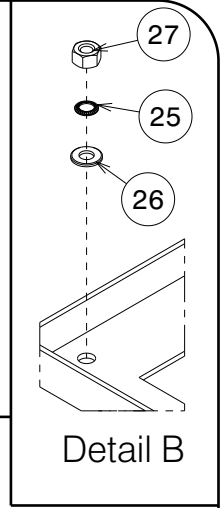

Detail B

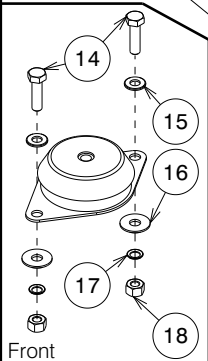
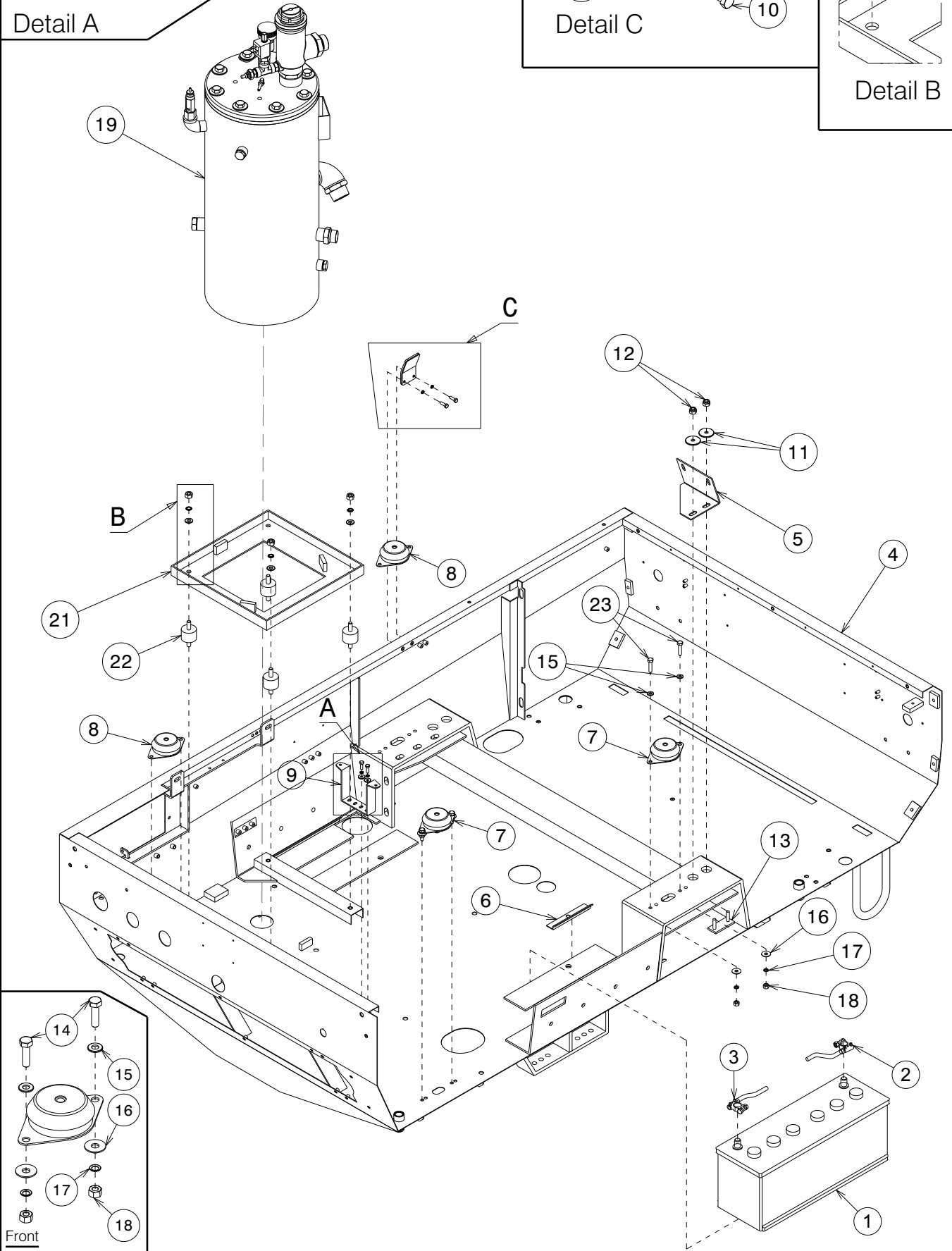

Front  
Silent block (7 & 8)



# PARTS LIST

## Motocompressor – D300T4F

PARTS LEGENDA: D300T4F – Clampings to the chassis

Tab. 06

REF	NAME	CODE	QUANTITY
1	Battery	174-040-S	1
2	Positive battery cable L=1270	252-054-S	1
3	Negative battery cable L=600	252-041-S	1
4	Chassis	038-10340-S	1
5	Intercooler pipe support	010-34504-S	1
6	Battery clamp	115-010-S	1
7	Silent block (Up to Serial No.C43143)	061-0243-S	2
	Silent block (From Serial No.C43144)	061-02470-S	2
8	Silent block (Up to Serial No.C43143)	061-0233-S	2
	Silent block (From Serial No.C43144)	061-02375-S	2
9	Fuses box support blade	120-21977-S	1
10	Hex head screw M6x20	132-063-S	4
11	Flat washer d.10x40x2.5	015-037-S	2
12	Self-locking nut M10	137-050-S	2
13	Intercooler pipe support clamping section	120-396500-S	1
14	Hex head screw M8x30	132-103-S	2
15	Flat washer 8,4x17x1,5 UNI 6592	015-030-S	8
16	Flat washer 8x24x2 UNI6593	015-031-S	8
17	Schnorr washer d.8	015-251-S	8
18	Hex nut M8 UNI 5587	135-040-S	8
19	Separator tank assembly	024-61656-S	1
20	Washer d.6	015-250-S	4
21	Separator tank support	010-070501-S	1
22	Silent block	061-028-S	4
23	Hexagonal head screw M8x30 UNI 5739	132-104-S	2
24	Washer d. 6.6x18x2	015-029-S	2
25	Schnorr washer d.10	015-252-S	4
26	Flat washer 10,2x21x2	015-032-S	4
27	Hex nut M10 (galvanized)	135-0502-S	4
28	Centering blade	120-039522-S	2

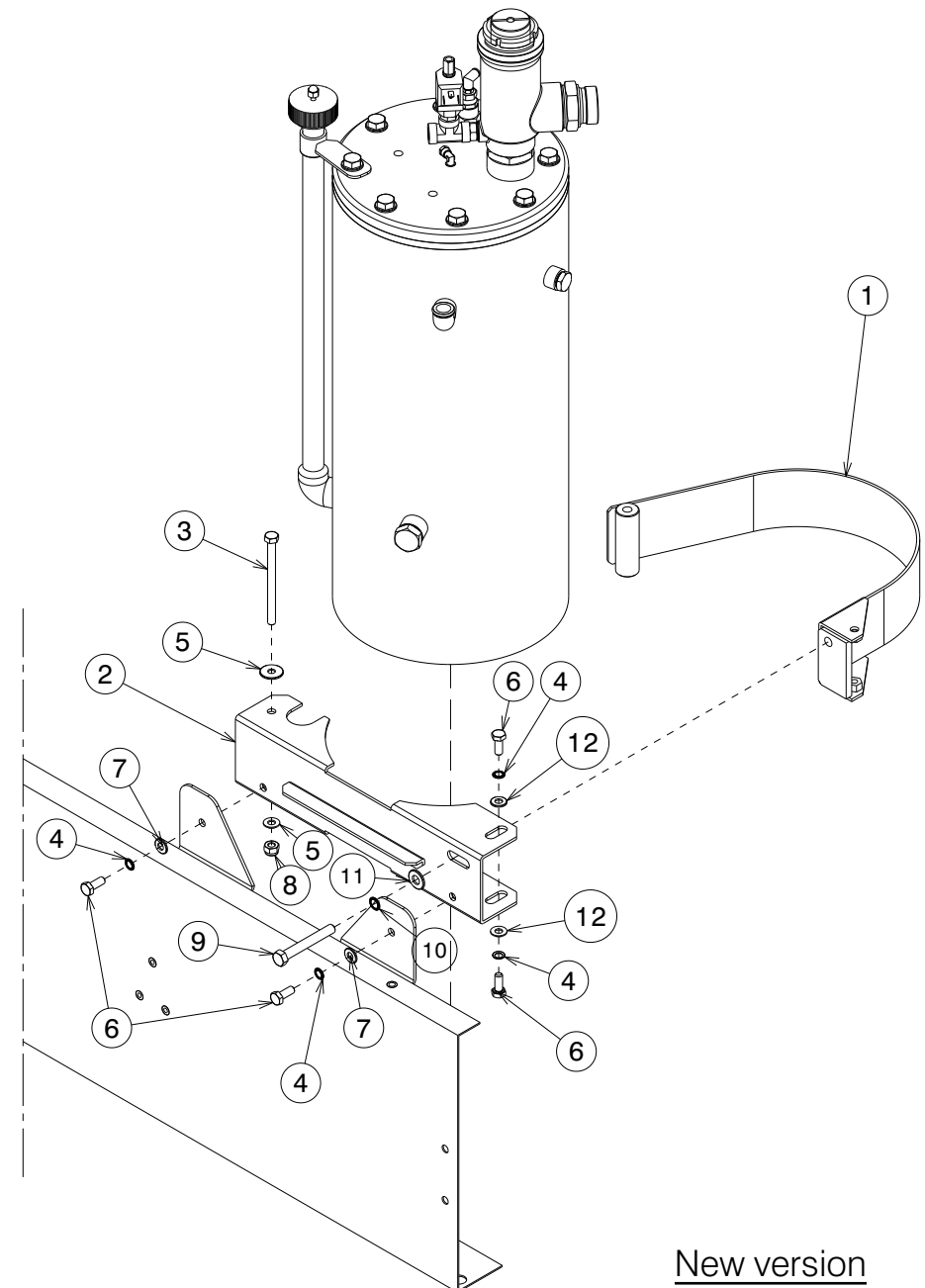
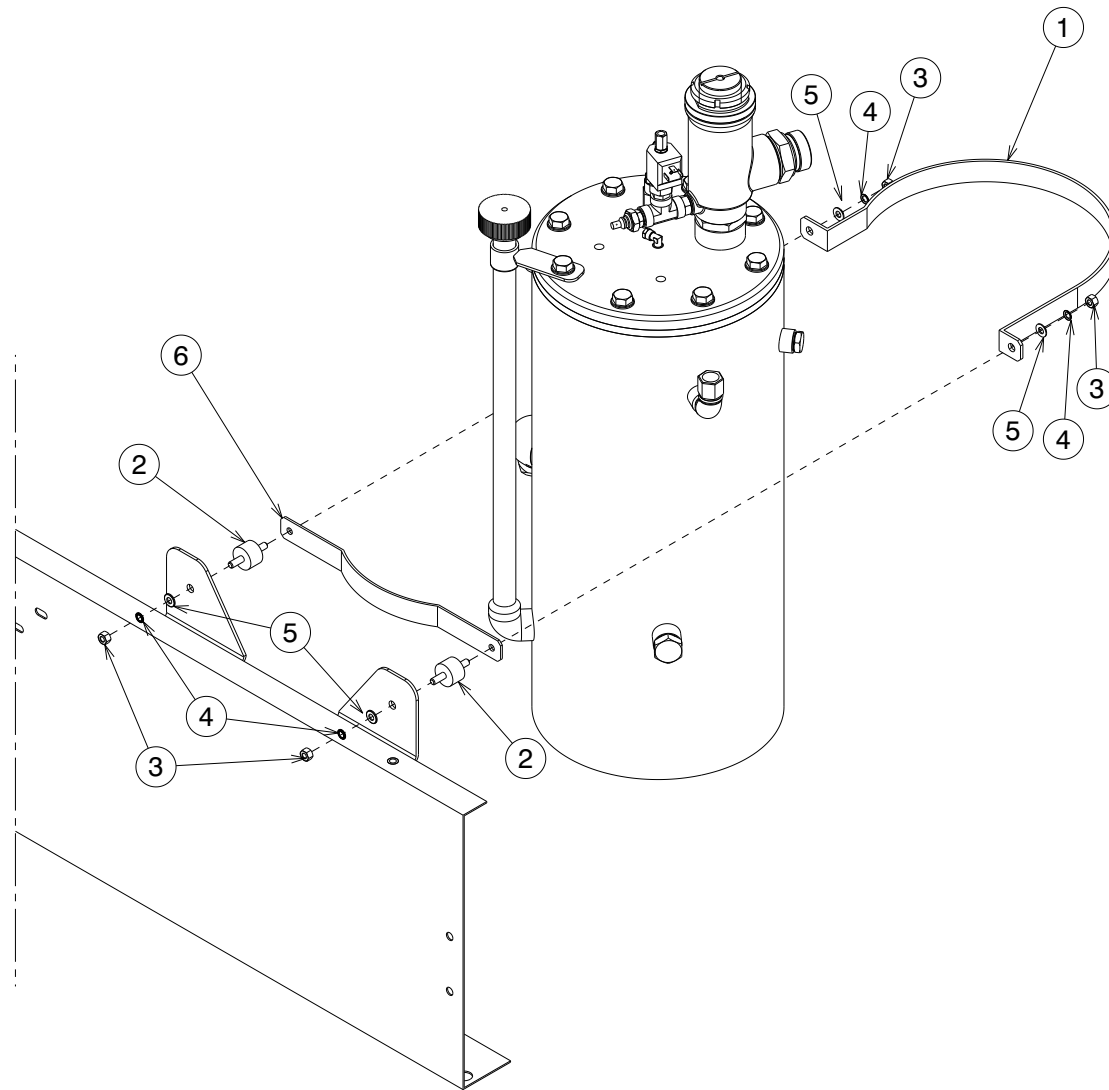
Old versionNew version



# PARTS LIST

## Motocompressor – D300T4F

PARTS LEGENDA: Separator tank support

Tab. 06.1

POSITION	DESCRIPTION	PART No.	QUANTITY
<b>Old version</b>			
1	Separator tank clamping ring	214-045-S	1
2	Silent block	061-013-S	2
3	Hex nut M8 UNI 5587	135-040-S	4
4	Schnorr washer d.8	015-251-S	19
5	Flat washer 8,4x17x1,5 UNI 6592	015-030-S	8
6	Separator tank support blade	120-2193-S	1
<b>New version</b>			
1	Separator tank clamping ring	214-04450-S	1
2	Separator tank support blade	120-212520-S	1
3	Hexagonal head screw M10x130	132-163-S	1
4	Schnorr washer d.10	015-252-S	4
5	Flat washer 10x30x2,5 UNI6593	015-033-S	2
6	Hex head screw . M10x25	132-142-S	4
7	Flat washer 10,2x21x2	015-032-S	2
8	Self-locking nut M10	137-050-S	1
9	Hex head screw . M12x65	132-199-S	1
10	Schnorr washer d.12	015-254-S	1
11	Flat washer d. 12x30x4	015-03980-S	1
12	Flat washer d. 10x40	015-037-S	2

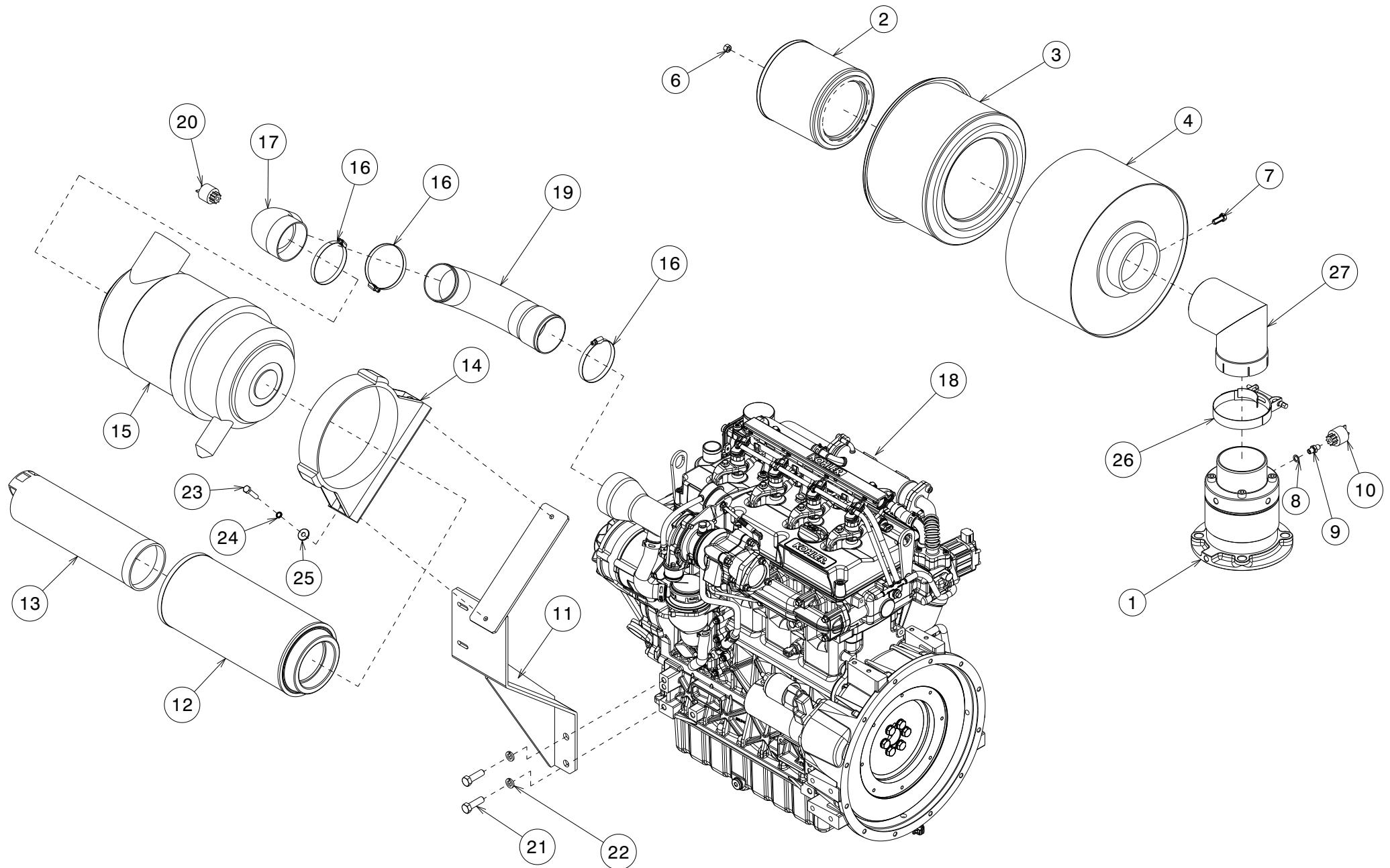



# PARTS LIST

## Motocompressor – D300T4F

LEGENDA: Air filters

Tab. 07

REF	NAME	CODE	QUANTITY
1	Regulator assembly	024-130-F	1
2	Air filter cartridge	162-583-S	1
3	Air filter cartridge	162-582-S	1
4	Air filter container	014-293-S	1
5	Elbow	111-10505-S	1
6	Hex nut M8 UNI 5587	135-040-S	1
7	Hex head screw M8x25 UNI 5739	132-102-S	1
8	Copper washer ( 1/8" )	015-005-S	2
9	Double screw ( 1/8" )	187-001-S	2
10	Air filter clogging signaller	257-048-S	1
11	Air filter container support (Up to Serial No. C39951)	010-345021-S	1
	Air filter container support	010-345022-S	1
12	Primary air filter	162-0085-S	1
13	Secondary air filter	162-0084-S	1
14	MANN air filter support	010-2417-S	1
15	MANN filter group	014-418-S	1
16	Pipe clamp d.70x90	149-145-S	3
17	MANN curve d.80 (Up to Serial No. C39951)	111-107-S	1
	MANN curve d.80	111-10705-S	1
18	Engine	165-42801-S	1
19	Engine intake pipe (Up to Serial No. C39951)	064-1706041-S	1
	Engine intake pipe	064-1706042-S	1
20	Air filter clogging sensor	257-0470-S	1
21	Hex head screw M12x40 screw	132-194-S	2
22	Elastic washers	139-060-S	2
23	Hex head screw M8x40 UNI 5739	132-105-S	2
24	Schnorr washer d.8	015-251-S	2
25	Flat washer 8x24x2 UNI6593	015-031-S	2
26	Pipe clamp d.97-104	149-1672-S	1





# PARTS LIST

## Motocompressor – D300T4F

PARTS LEGENDA: D300T4F – Canopy

Tab. 08

REF	NAME	CODE	QUANTITY
1	Handle	209-003-S	1
2	Rear removable panel	124-308801-S	1
3	Fixed canopy	036-158151-S	1
4	Mobile canopy (Up to Serial No. C40499)	036-159151-S	1
	Mobile canopy (From serial No. C40500)	036-1591512-S	1
5	Lifting piston	091-09470-S	2
6	Lifting piston clamping support	120-39340-S	2
7	Hexagon socket countersunk head 8x 16 UNI 5933	146-120-S	4
8	Handle	209-009-S	2
9	Plate	208-004-S	1
10	Rubber plate	177-201-S	1
11	Large head screw 6x20	243-010-S	2
12	Air intake panel	022-059251-S	1
13	Air intake sound proof panel	124-3054120-S	5
14	Hex head screw M8x40 UNI 5739	132-105-S	4
15	Flat washer 8x24x2 UNI6593	015-031-S	4
16	Hex socket head cap screw M8x25 UNI 5931	133-133-S	4
17	Plate	208-001-S	2
18	Hex head screw . M6x20	132-063-S	4
19	Socket head cap screw 6x40 UNI7380	150-505-S	4
20	Large head screw M6x16	243-009-S	30
21	Hex head screw . M8x20 UNI 5739	132-101-S	8
22	Schnorr washer d.8	015-251-S	8
23	Flat washer 8x24x2 UNI6593	015-031-S	8
24	Hinge (From serial No. C40500)	007-007501-S	2
25	Hex socket countersunk head 10x20(From serial No. C40500)	146-151-S	4

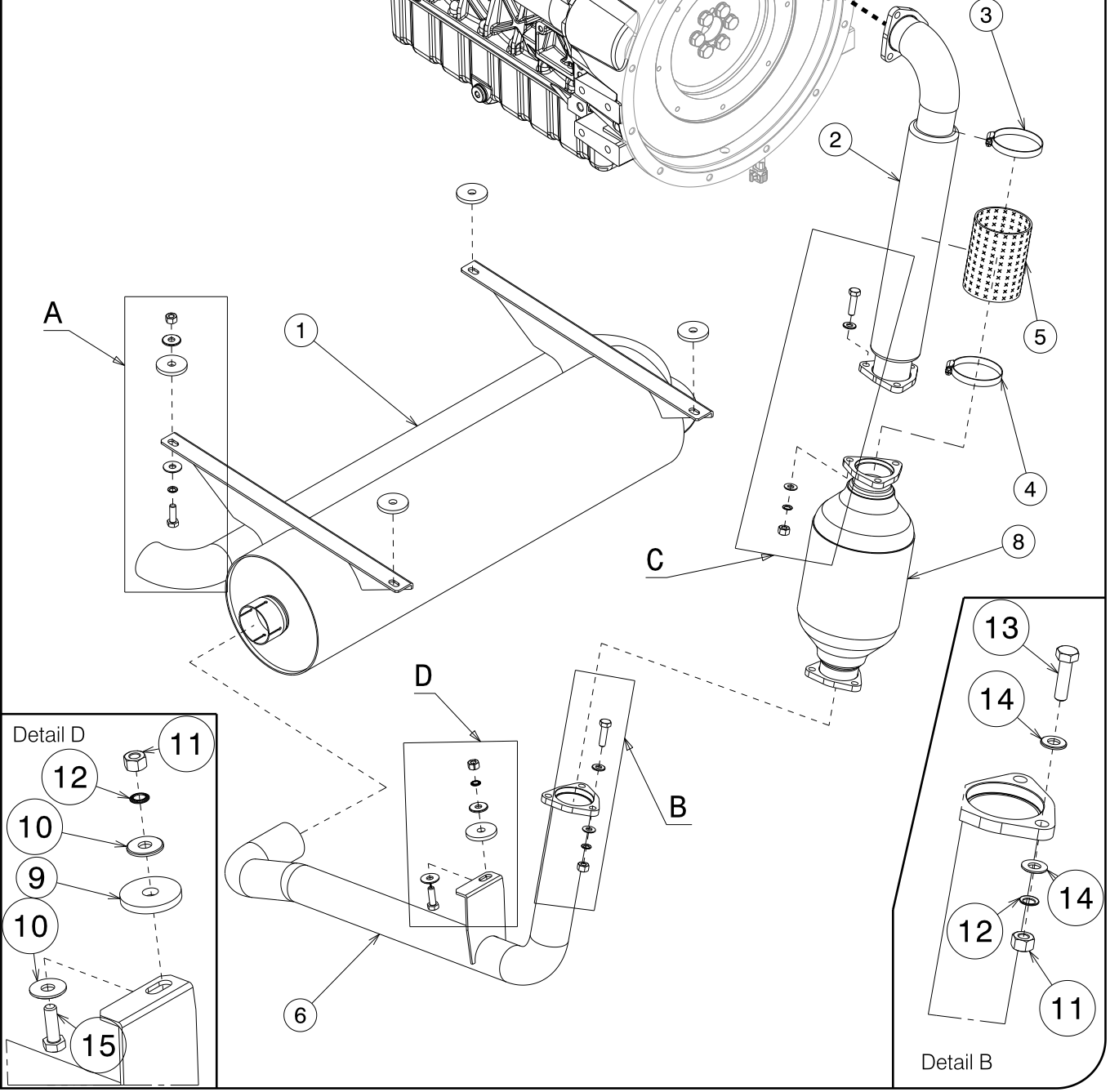
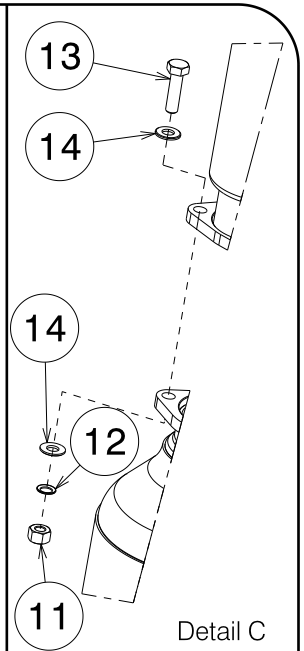
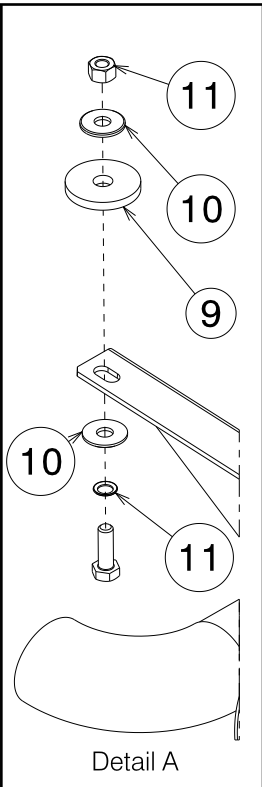



# PARTS LIST

## Motocompressor – D300T4F

PARTS LEGENDA: D300T4F – Connections

Tab. 09.1

REF	NAME	CODE	QUANTITY
1	Muffler	042-0851830-S	1
2	Flex pipe	090-101805-S	1
3	Pipe clamp d.50x70	149-140-S	1
4	Pipe clamp d.40x60	149-135-S	1
5	Fiber glass braiding d.70	097-0325-G	1
6	Muffler collector	119-07450-S	1
7	Engine	165-4280-S	1
8	Catalyst (supplied with engine)	---	1
9	Seal for muffler d.40 th..5	023-077-S	5
10	Flat washer 8x24x2 UNI6593	015-031-S	10
11	Hex nut M8 UNI 5587	135-040-S	11
12	Schnorr washer d.8	015-251-S	11
13	Hex head screw M8x30	132-103-S	6
14	Flat washer 8,4x17x1,5 UNI 6592	015-030-S	12
15	Hex head screw M8x25 UNI 5739	132-102-S	1

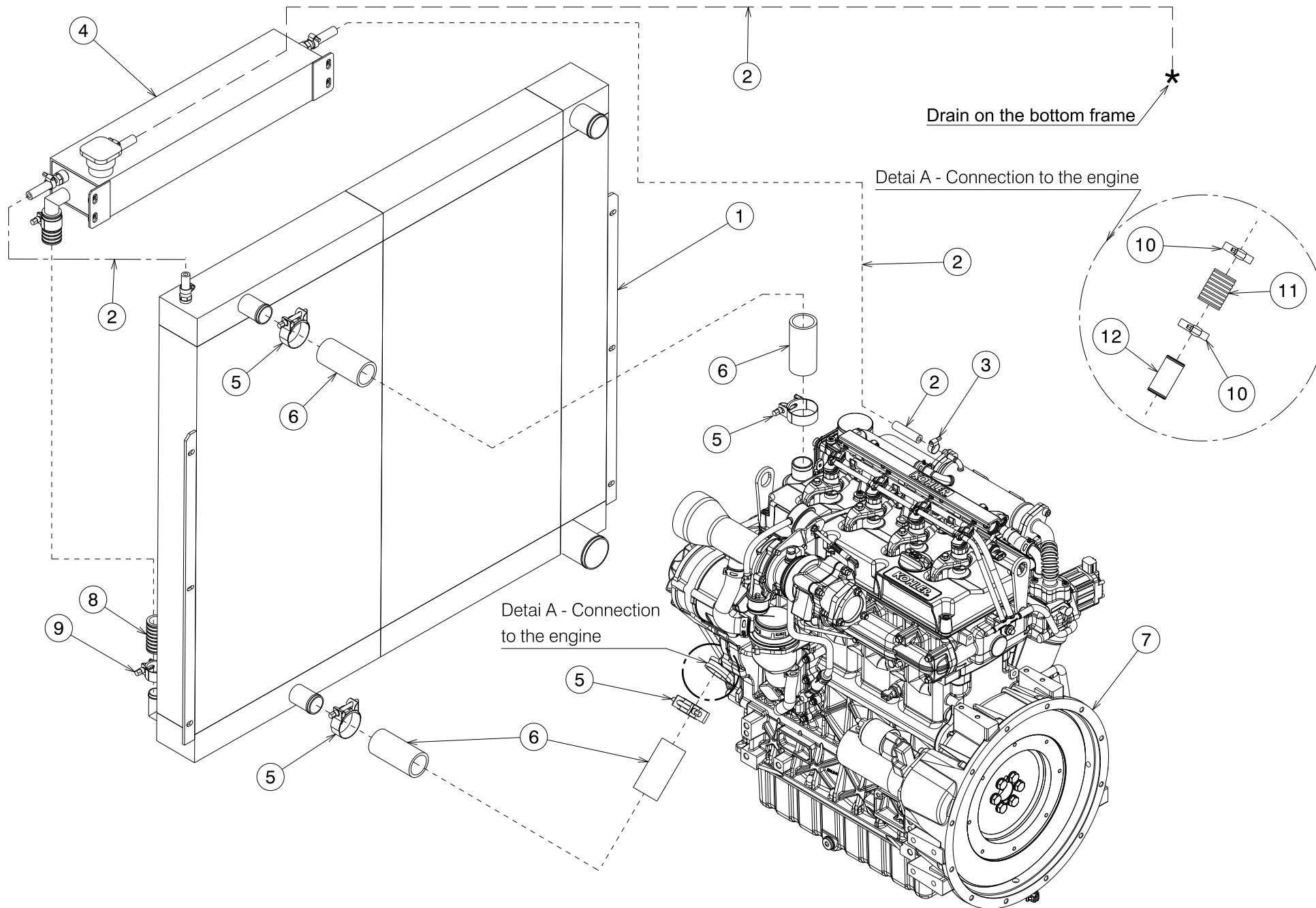



# PARTS LIST

## Motocompressor – D300T4F

PARTS LEGENDA: D300T4F – Connections

Tab. 09.2

REF	NAME	CODE	QUANTITY
1	Air-Oil radiator	011-09650-S	1
2	Anti-oil pipe for fuel 15x8	089-1203-S	3
3	Pipe clamp 10x16	149-007-S	1
4	Expansion tank	201-018150-S	1
5	Clamp cost.torque d.32-54	149-1321-S	4
6	Calorflex pipe d.38x48	089-006-S	2
7	Engine	165-4280-S	1
8	Pipe d. 25x34	089-009.5-S	1
9	Clamp 31-34	149-305-S	1
10	Pipe clamp 32x50 (From Serial No.C40100)	149-131-S	2
11	Radiator pipe d.35x43 (From Serial No.C40100)	089-00560-S	10"
12	Reduction d.35 L=70 (From Serial No.C40100)	190-613953-S	1

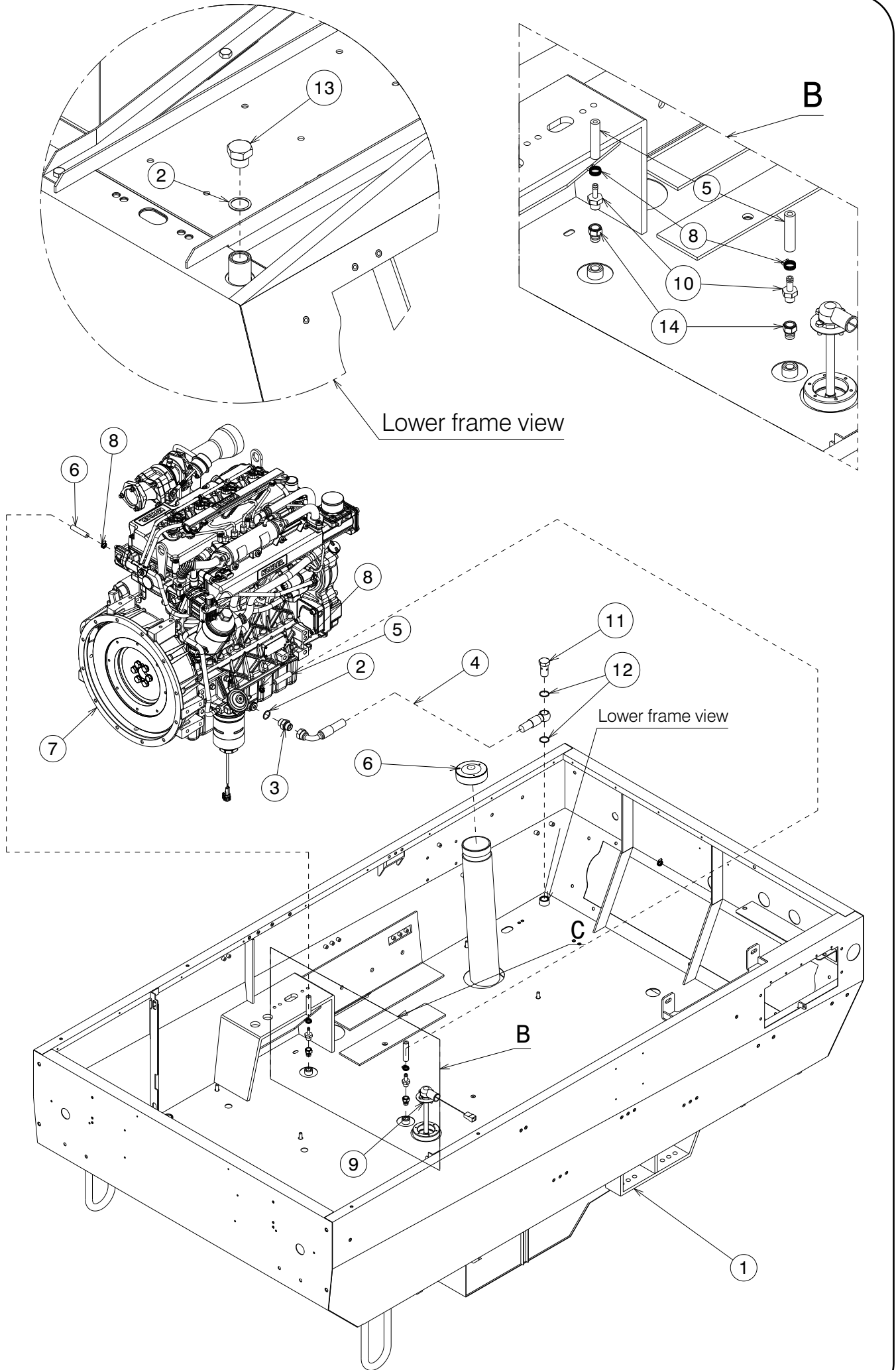



# PARTS LIST

## Motocompressor – D300T4F

PARTS LEGENDA: D300T4F – Connections

Tab. 09.3

REF	NAME	CODE	QUANTITY
1	Chassis	038-10340-S	1
2	Copper washer ( 1/2" )	015-012-S	2
3	Double screw ( 1/2" foro 12.6 )	187-045-S	1
4	Pipe 1/2"	065-176.402-S	1
5	Anti-oil pipe for fuel 15x8	089-120-S	1
6	Gasoil plug	193-016-S	1
7	Engine	165-4280-S	1
8	Pipe clamp 10x16	149-007-S	4
9	Gasoil level control assembly	024-0193-S	1
10	M fitting ( 1/4" ) d.8 with OR	148-198.21-S	2
11	Screw ( 1/2" )	188-100-S	1
12	Copper washer ( d. 24.1 )	015-014-S	2
13	Iron plug ( 1/2" )	106-125-S	1
14	Straight adapter fitting 1/4"M conical – 1/4"F cil.	148-03600-S	1

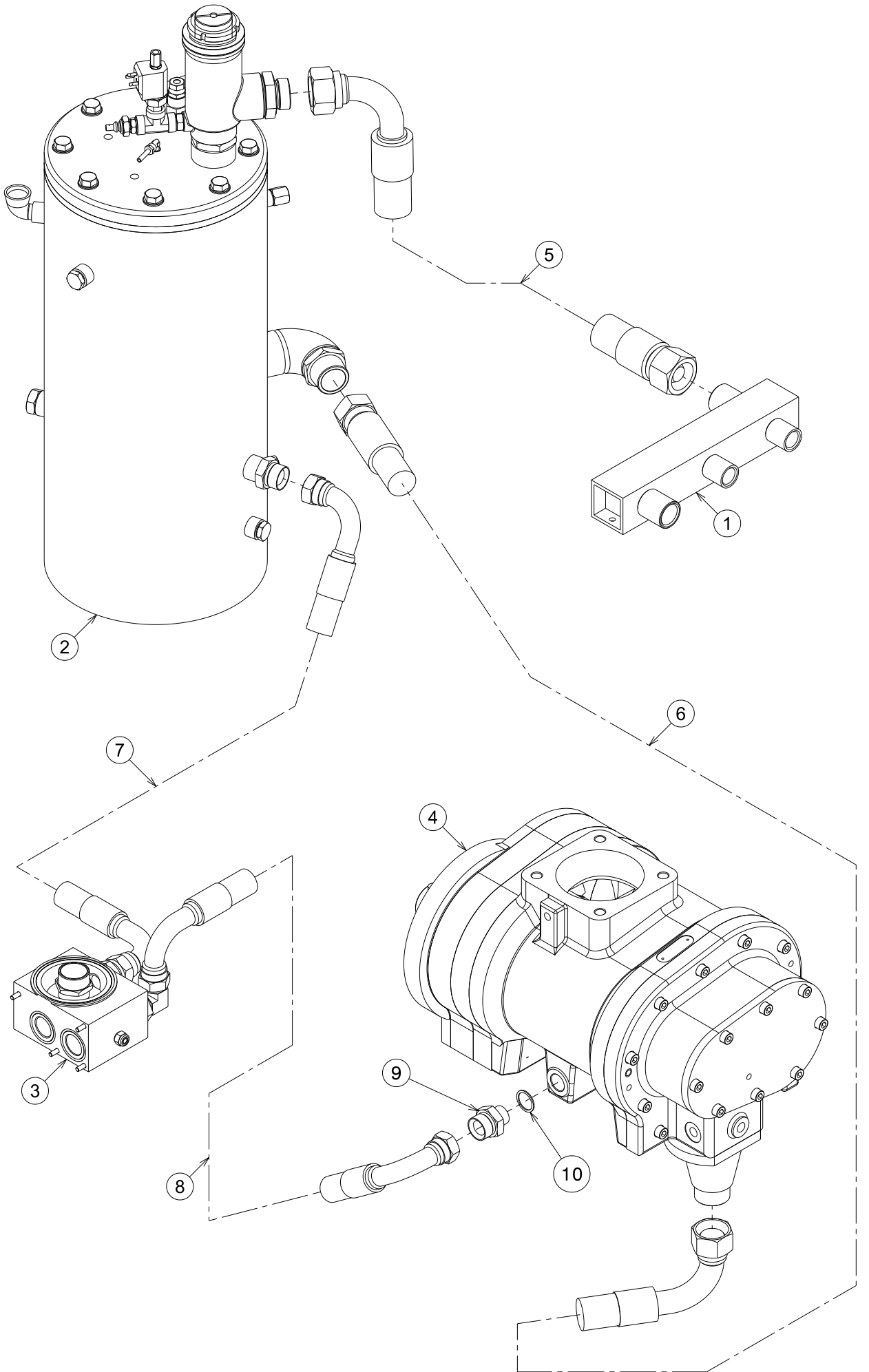



# PARTS LIST

## Motocompressor – D300T4F

PARTS LEGENDA: D300T4F – Connections

Tab. 09.4

REF	NAME	CODE	QUANTITY
1	Exit valves clamping sleeve	063-109-S	1
2	Separator tank	024-61656-F	1
3	By-pass valve assembly	024-01152-F	1
4	Air end assembly	024-0971-F	1
5	Pipe (1 1/4")	065-3019.59-S	1
6	Pipe (1 1/2")	065-314.016-S	1
7	Pipe (1")	065-882.39-S	1
8	Pipe (1")	065-882.87-S	1
9	Double screw ( 3/4" a 1" ) foro 19.1	187-065-S	1
10	Copper washer ( 3/4" )	015-015-S	1

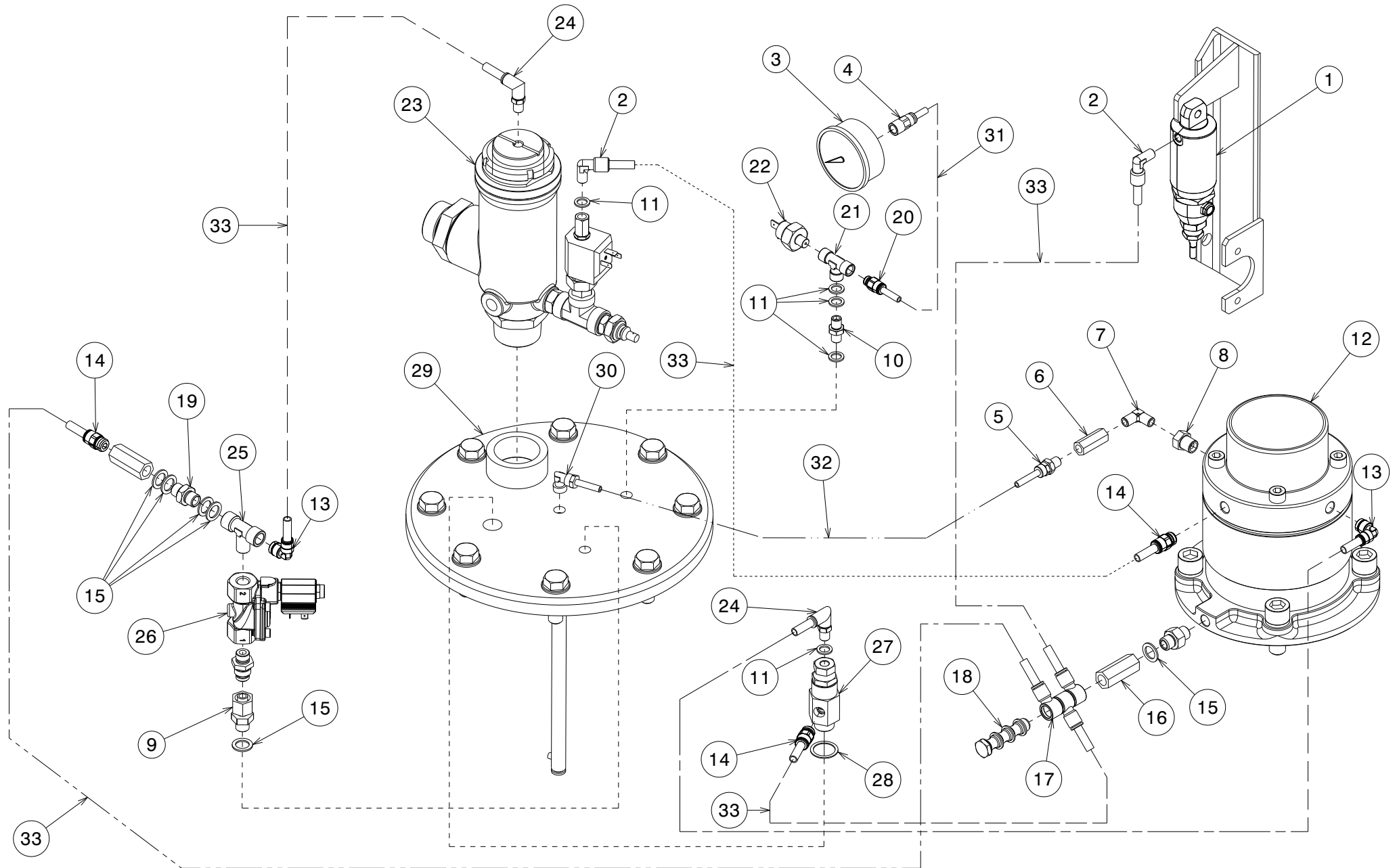



# PARTS LIST

## Motocompressor – D300T4F

PARTS LEGENDA: D300T4F – Pneumatic connections

Tab. 09.5

REF	NAME	CODE	QUANTITY
1	Accelerator piston assembly	044-0040523-S	1
2	Quick coupling 90° ( 1/8" ) for pipe d.8	148-572-S	2
3	15 Bar pressure gauge	206-020-S	1
4	Straight quick coupling F ( 1/8" ) for pipe d.6	148-5765-S	1
5	Straight coupling ( 1/8" ) for pipe d.6	148-040-S	1
6	Non return valve ( 1/8" )	033-001-S	1
7	Adaptor clamping 90° M+M ( 1/8" )	148-288-S	1
8	Reduction M with + F cil ( 1/4" – 1/8" )	190-010-S	1
9	Straight coupling ( 1/4" )	148-7115-S	1
10	Double screw ( 1/8" )	187-001-S	1
11	Copper washer ( 1/8" )	015-005-S	5
12	Regulator assembly	024-130-F	1
13	Quick coupling 90° ( 1/4" ) per tubo d.8	148-573.5-S	2
14	Straight quick coupling ( 1/4" ) per tubo d.8	148-575-S	3
15	Copper washer ( 1/4" )	015-007-S	6
16	Non return valve ( 1/4" )	033-0178-S	1
17	Super quick coupling ( 1/4" )	148-5901-S	3
18	Quick coupling ( 1/4" )	148-5900-S	1
19	Double screw ( 1/4" )	187-005-S	1
20	Straight quick coupling F ( 1/8" ) for pipe d.6	148-576-S	1
21	T fitting F+F+F ( 1/8" )	148-141-S	1
22	Oil pressure switch	154-025-S	1
23	Minimum pressure valve assembly	024-03111-F	1
24	Straight quick coupling ( 1/8" ) for pipe d.6	148-8001-S	2
25	T fitting F+M+F ( 1/4" )	148-194-S	1
26	Solenoid valve	160-0871-S	1
27	Pressure regulation valve	024-032.1-F	1
28	Copper washer ( 1/2" )	015-012-S	1
29	Separator tank closing flange	004-0635-S	1
30	Fitting 90' ( 1/4" ) for pipe d. 6	148-090-S	1
31	Rilsan blue pipe 6x4	089-0605-S	1
32	Polyamidis pipe 6x4	089-060-S	1
33	Rilsan blue pipe 8x6	089-0705-S	5

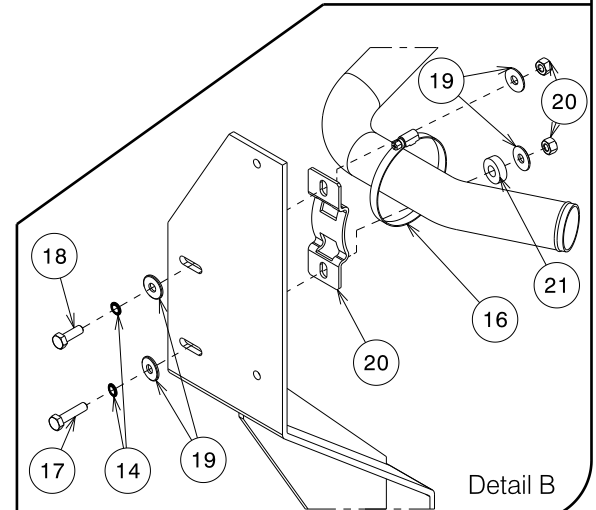
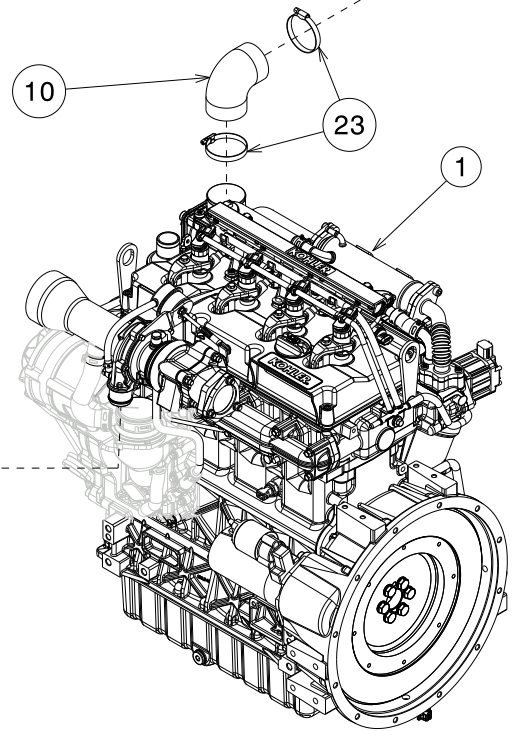
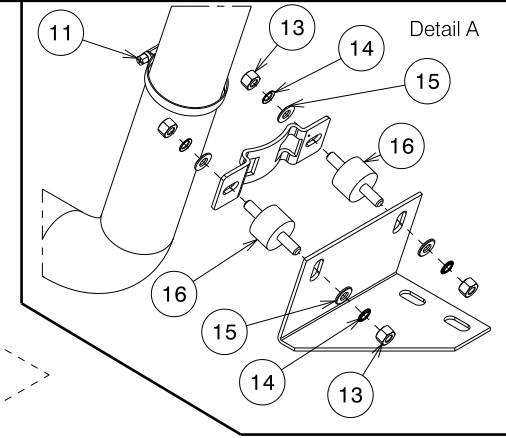
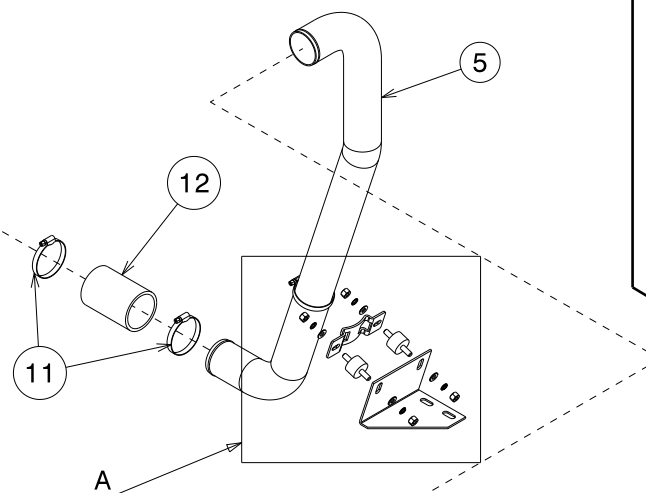
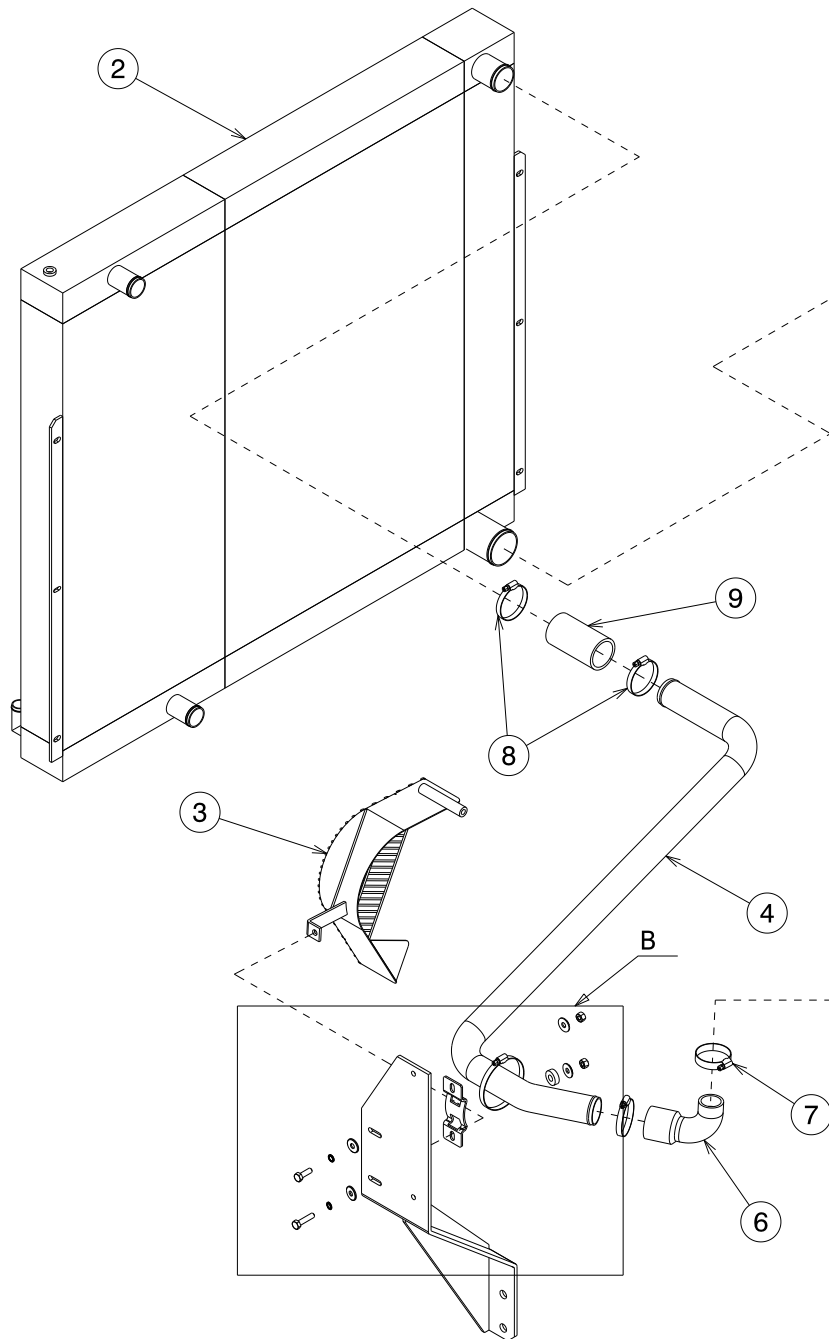

Detail B



# PARTS LIST

## Motocompressor – D300T4F

PARTS LEGENDA: D300T4F – Intercooler connections

Tab. 09.6

REF	NAME	CODE	QUANTITY
1	Engine	165-4280-S	1
2	Air-Oil radiator	011-09650-S	1
3	Protection belts grid	005-0955-S	1
4	Intercooler outlet pipe	064-170600-S	1
5	Intercooler inlet pipe	064-170602-S	1
6	Silicone elbow	111-106720-S	1
7	Pipe clamp 32x54	149-1321-S	1
8	Pipe clamp d.45x67	149-1360-S	3
9	Silicone pipe	089-0155-S	4.70 "
10	Silicone elbow	111-10605-S	1
11	Pipe clamp d.50x70	149-140-S	1
12	Silicone pipe	089-0325-S	4.70 "
13	Hex nut M8 UNI 5587	135-040-S	4
14	Schnorr washer d.8	015-251-S	6
15	Flat washer 8,4x17x1,5 UNI 6592	015-030-S	4
16	Pipe clamp d.70x90	149-145-S	1
17	Hexagonal head screw M8x30 UNI 5739	132-104-S	1
18	Hex head screw M8x25 UNI 5739	132-102-S	1
19	Flat washer 8x24x2 UNI6593	015-031-S	4
20	Clamp support	010-1530-S	1
21	Spacer	009-0875-S	1
22	Silent block	061-013-S	2
23	Pipe clamp d.57x79 (From Serial No.C40224)	149-1420-S	4

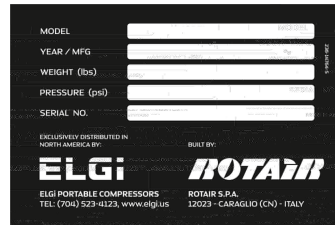

<b>⚠ DANGER</b>	<b>⚠ WARNING</b>	<b>⚠ CAUTION</b>
<p><b>Hazardous Voltage.</b> Presence of 24 V DC battery charger. Use of equipment with a damaged battery can cause personal injury or death.</p> <p><b>Crush Hazard.</b> Moving parts can crush. Keep hands clear.</p> <p><b>Ensure Guards.</b> Ensure guards are in place before operating the equipment.</p> <p><b>Qualified Personnel.</b> Only a qualified person can correct and only the qualified personnel.</p>	<p><b>Do Not Remove.</b> Do not remove tags, plugs or other components when compressor is operational or in pressure.</p> <p><b>Relieve Pressure.</b> Relieve compressor and release all internal pressure before opening or closing any other components, plugs or other components.</p> <p><b>Corrosive Substances.</b> Presence of corrosive fluids inside the equipment. Improper handling can cause severe injury.</p> <p><b>Hot Surfaces.</b> Compressor can create severe burning steam. Do not touch hot surfaces.</p>	<p><b>Read Manual.</b> Read instruction manual before start of operations with the equipment.</p> <p style="background-color: #0056b3; color: white; text-align: center;"><b>NOTICE</b></p> <p style="background-color: #0056b3; color: white; text-align: center;"><b>Starting Instructions</b></p> <p>1. Should the machine be operated with a temperature lower than 0°C, let it run with the fuel system (generator, generator oil) for 10 minutes before starting.</p> <p>2. In the case of problems in starting, check the fuel system (generator oil) and the generator system.</p>

4

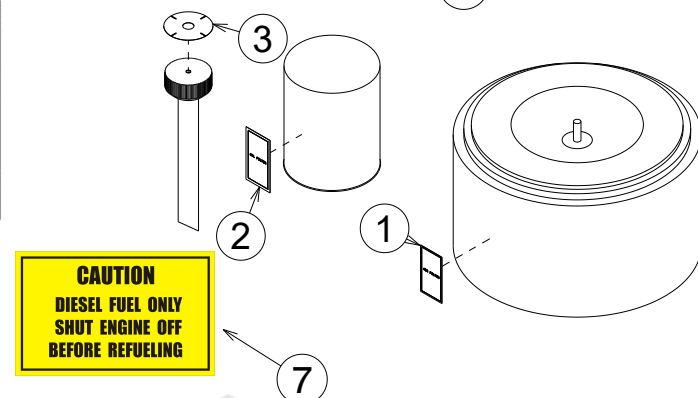



# PARTS LIST

## Motocompressor – D300T4F

**PARTS LEGENDA:** D300T4F – Strickers

Tab. 10

REF	NAME	CODE	QUANTITY
1	Satiny air filter sticker	238-001-S	1
2	Satiny oil filter sticker	238-002-S	2
3	Oil level control sticker	238-003-S	1
4	Warnings sticker	238-1240.2-S	1
5	“Designed in the U.S.A.” sticker	238-35830-S	1
6	Rotair sticker	238-0213.2-S	2
7	“Caution Diesel Only” sticker	238-097600-S	1
8	Serial No. plate	238-14763-S	1
9	“D300T4F” sticker	238-325843.1-S	2

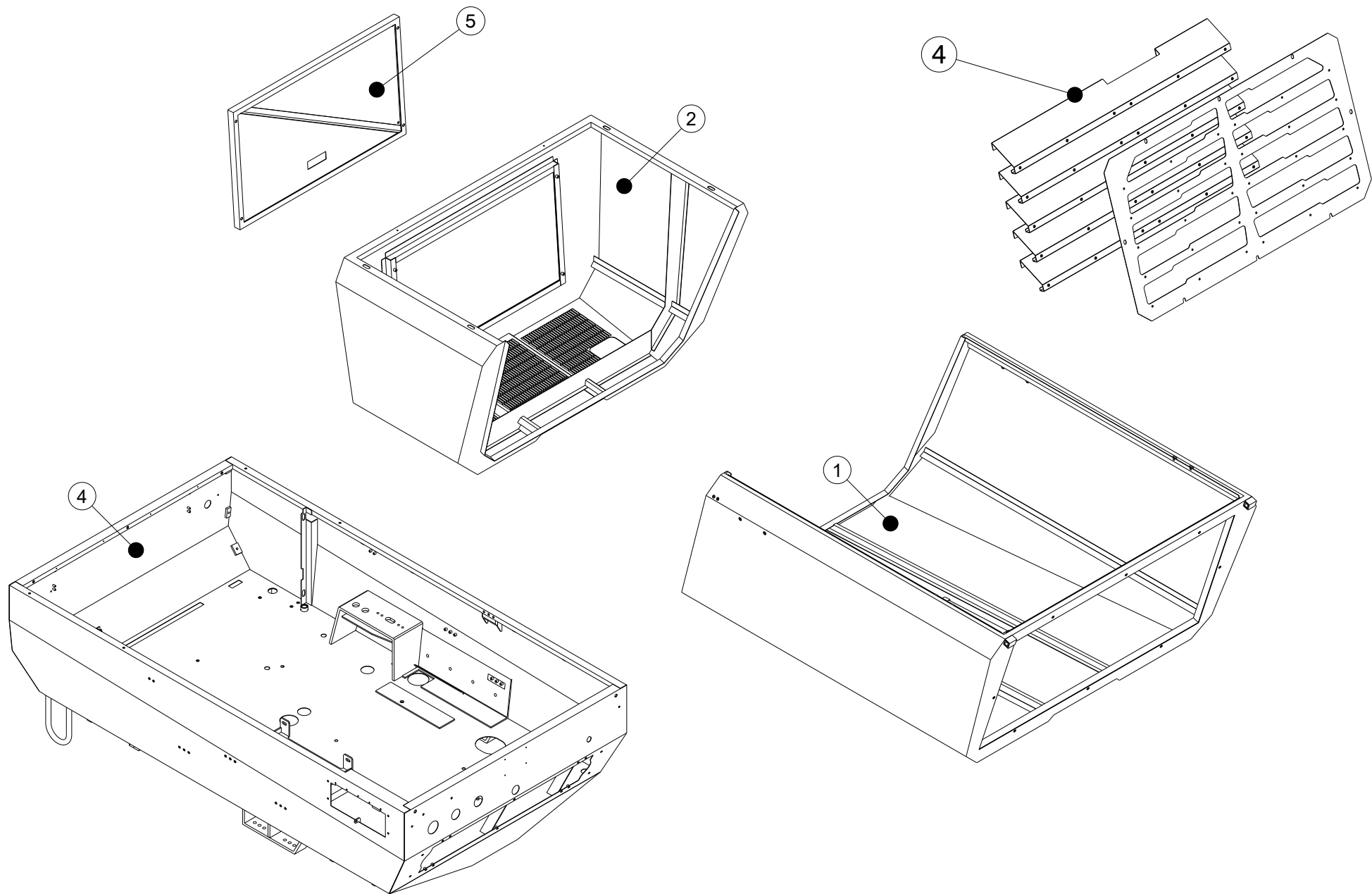



# PARTS LIST

## Motocompressor – D300T4F

**PARTS LEGENDA:** D300T4F – Soundproofing

Tab. 11

REF	NAME	CODE	QUANTITY
1	Mobile canopy sound-proof kit	204-309221-S	1
2	Fixed canopy sound-proof kit	204-309121-S	1
3	Chassis sound-proof kit	204-345508-S	1
4	Air intake sound-proof kit	204-335432-S	1
5	Rear removable panel sound-proof kit	204-345506-S	1



Electrical harness

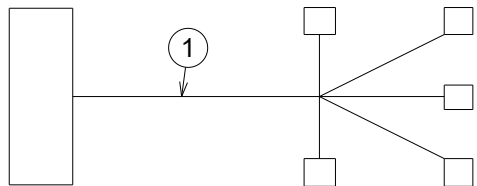



# PARTS LIST

## Motocompressor – D300T4F

PARTS LEGENDA: D300T4F – Control panel – Electrical harness

Tab. 12

REF	NAME	CODE	QUANTITY
1	Electrical harness	224-46575-S	1
2	Control panel	040-051600-S	1
3	Electronic card	269-408-S	1
4	15 Bar pressure gauge	206-020-S	1
5	Green button switch	154-054-S	1
6	Contact Holder	127-376-S	1
7	Two-positions selector	249-022-S	1
8	Contact holder	127-376-S	1
9	Contact	127-375-S	4
10	Anti-dust plastic plug for push-buttons	106-290-S	1
11	Electronic hour counter	180-010-S	1
12	Rubber seal for hour counter	023-219-S	1
13	Control panel sticker	238-1632008-S	1
14	"Yellow" led	183-041-S	2
15	"Red" led	183-011-S	3
16	Fuel level indicator	186-020-S	1

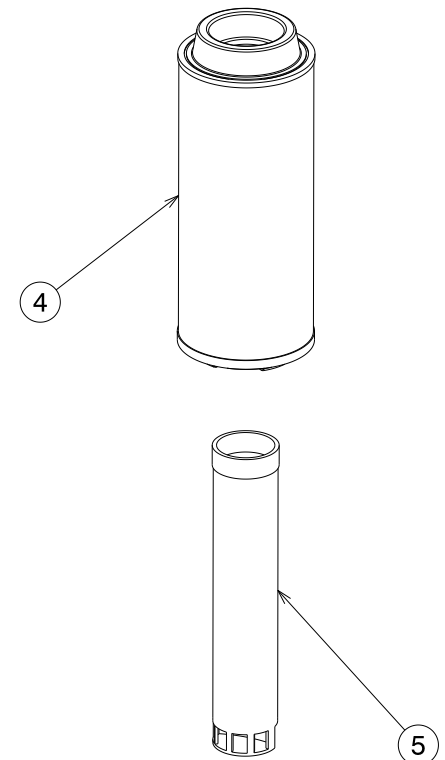
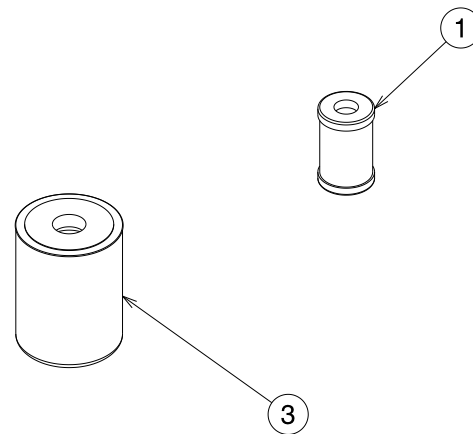
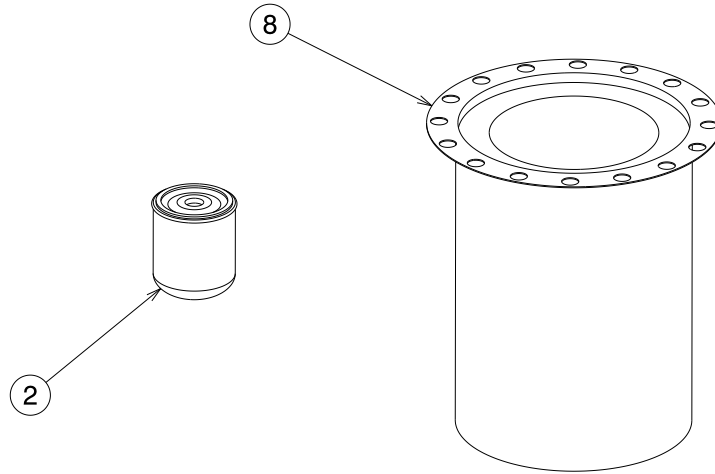
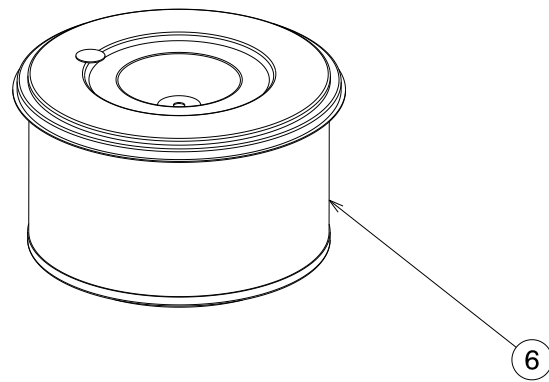
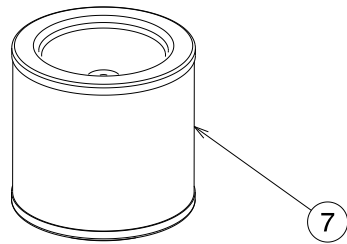



## PARTS LIST

### Motocompressor – D300T4F

PARTS LEGENDA: Maintenance Kit

Tab.13

REF	NAME	CODE	QUANTITY
<b>Filter kit 500 Hrs</b>			
1	Engine gasoil filter	191-0950-S	2
2	Compressor oil filter	099-009-S	1
3	Engine oil filter	099-1010-S	2
4	1° engine air filter	162-0085-S	1
5	2° engine air filter	162-0084-S	1
6	Compressor air filter 1°	162-582-S	1
7	Compressor air filter 2°	162-583-S	1
<b>Filter kit 2000 Hrs</b>			
1	Engine gasoil filter	191-0950-S	8
2	Compressor oil filter	099-009-S	4
3	Engine oil filter	099-1010-S	8
4	1° engine air filter	162-0085-S	4
5	2° engine air filter	162-0084-S	4
6	Compressor air filter 1°	162-582-S	4
7	Compressor air filter 2°	162-583-S	4
8	Separator filter	157-180-S	1