



Metal Platform Cart

Owner's Manual



⚠ WARNING: Read carefully and understand all ASSEMBLY AND OPERATION INSTRUCTIONS before operating. Failure to follow the safety rules and other basic safety precautions may result in serious personal injury.

Items #63755, #63756, #63757, and #63758

READ & SAVE THESE INSTRUCTIONS

Thank you very much for choosing an Ironton® product!

For future reference, please complete the owner's record below:

Serial Number/Lot Date Code: _____

Purchase Date: _____

Save the receipt, warranty, and this manual. It is important that you read the entire manual to become familiar with this product before you begin using it.

This platform cart is designed for certain applications only. Northern Tool and Equipment is not responsible for issues arising from modification or improper use of this product such as an application for which it was not designed. We strongly recommend that this product not be modified and/or used for any application other than that for which it was designed.

For technical questions, please call **1-800-222-5381**.

Table of Contents

Intended Use.....4

Packaging Contents.....4

Technical Specifications4

Important Safety Information4

Specific Operation Warnings5

Main Parts of Cart6

Assembly Instructions.....6

Operating Instructions.....9

After Each Use.....9

Maintenance9

Troubleshooting.....9

Parts Diagram10

Parts List10

Replacement Parts11

Limited Warranty12

Intended Use

The Ironton Metal Platform Cart makes it easy to move large, awkward, and heavy loads. The quick-release handle can be assembled on either side.

Packaging Contents

- Platform
- Casters (4)
- Handle
- Pins (2)
- Bolts (16)
- Washers (32)

Technical Specifications

Property	63755	63756	63757	63758
Capacity (lb.)	1000	1000	1000	1000
Platform Size (in.)	24x48	30x48	30x60	36x72
Caster Size (in.)	8	8	8	8

Important Safety Information

⚠️WARNING

- Read and understand all instructions. Failure to follow all instructions may result in serious injury or property damage.
- The warnings, cautions, and instructions in this manual cannot cover all possible conditions or situations that could occur. Exercise common sense and caution when using this tool. Always be aware of the environment and ensure that the tool is used in a safe and responsible manner.
- Do not allow persons to operate or assemble the product until they have read this manual and have developed a thorough understanding of how it works.
- Do not modify this product in any way. Unauthorized modification may impair the function and/or safety and could affect the life of the product. There are specific applications for which the product was designed.
- Use the right tool for the job. DO NOT attempt to force small equipment to do the work of larger industrial equipment. There are certain applications for which this equipment was designed. This product will be safer and do a better job at the capacity for which it was intended. DO NOT use this equipment for a purpose for which it was not intended.
- Industrial or commercial applications must follow OSHA requirements.

⚠️WARNING

WORK AREA SAFETY

- Inspect the work area before each use. Keep work area clean, dry, free of clutter, and well-lit. Cluttered, wet, or dark work areas can result in injury. Using the product in confined work areas may put you dangerously close to cutting tools and rotating parts.
- Keep children and bystanders away from the work area while operating the tool. Do not allow children to handle the product.

⚠️WARNING

PERSONAL SAFETY

- Stay alert, watch what you are doing, and use common sense when operating the tool. Do not use the tool while you are tired or under the influence of drugs, alcohol, or medication. A moment of inattention while operating the tool may result in serious personal injury.
- Dress properly. Do not wear loose clothing, dangling objects, or jewelry. Keep your hair, clothing and gloves away from moving parts. Loose clothes, jewelry, or long hair can be caught in moving parts. Air vents on the tool often cover moving parts and should be avoided.
- Wear the proper personal protective equipment when necessary. Use ANSI Z87.1 compliant safety goggles (not safety glasses) with side shields, or when needed, a face shield. Use a dust mask in dusty work conditions. Also use non-skid safety shoes, hardhat, gloves, dust collection systems, and hearing protection when appropriate. This applies to all persons in the work area.
- Do not overreach. Keep proper footing and balance at all times.

⚠️CAUTION

CART USE AND CARE

- Do not force the cart. Products are safer and do a better job when used in the manner for which they are designed. Plan your work, and use the correct product for the job.
- Check for damaged parts before each use. Carefully check that the product will operate properly and perform its intended function. Replace damaged or worn parts immediately. Never operate the product with a damaged part.
- Store the product when it is not in use. Store it in a dry, secure place out of the reach of children. Inspect the tool for good working condition prior to storage and before re-use.
- Use only accessories that are recommended by the manufacturer for use with your product. Accessories that may be suitable for one product may create a risk of injury when used with another tool. Never use an accessory that has a lower operating speed or operating pressure than the tool itself.

Specific Operation Warnings

⚠️WARNING

- Do not exceed the rated load capacity of 1000 lb.
- Use only on a hard, level surface.

- Do not use to transport people or animals.
- Do not use to sit or ride on cart.
- Before moving the load, ensure that the load is centered and properly secured. Do not move unstable loads.
- Do not use a damaged cart or a cart that is not working properly.

Main Parts of Cart

Subassembly
Platform
Casters
Handle
Pins, Bolts, and Washers

Assembly Instructions

Tools required (not provided): a 15mm adjustable wrench.

1. Attach the four casters (#2 and #3) to the platform (#1) using the flat washers (#7), the spring washers (#8), and the M10 x 20 bolts (#6).

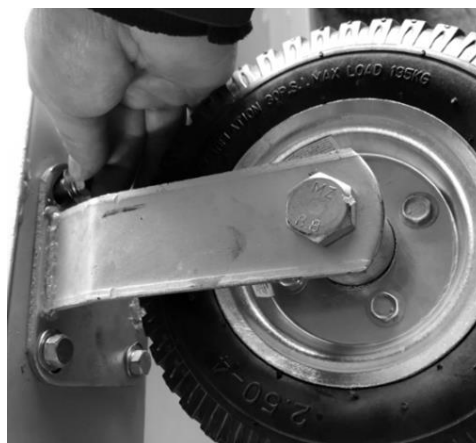



2. Insert the handle (#4) into the holes of the platform and secure the handle with the provided pins (#5) firmly. The handle can be put on either side. If put on the swivel caster side, the cart will be easier to steer.





Operating Instructions

⚠WARNING

- Do not exceed the rated load capacity of 1000 lb.

Place the load on the platform cart and move it by pushing the handle with both hands.



After Each Use

Store the cart in a clean, dry area. Clean the cart with a damp cloth.

Maintenance

Maintain the cart by adopting a program of conscientious repair and maintenance in accordance with the following recommended procedures. It is recommended that the general condition of any tool be examined before it is used. Keep your tool in good repair. Keep handles dry, clean, and free from oil and grease. The following chart is based on a normal operation schedule.

Maintenance Interval	Maintenance Point
After the first 20 operating hours	Tighten loose bolts. Clean the casters and platform.

Troubleshooting

Use the table below to troubleshoot problems before contacting service personnel or your local dealer. If the problem continues after troubleshooting, call your local dealer for assistance.

Failure	Possible Cause	Corrective Action
Casters do not roll smoothly.	Bolts are loose.	Check all the bolts and fasten if needed.
	Casters' inner bearings are dirty or rusted	Apply oil to inner bearings if needed.

Parts Diagram

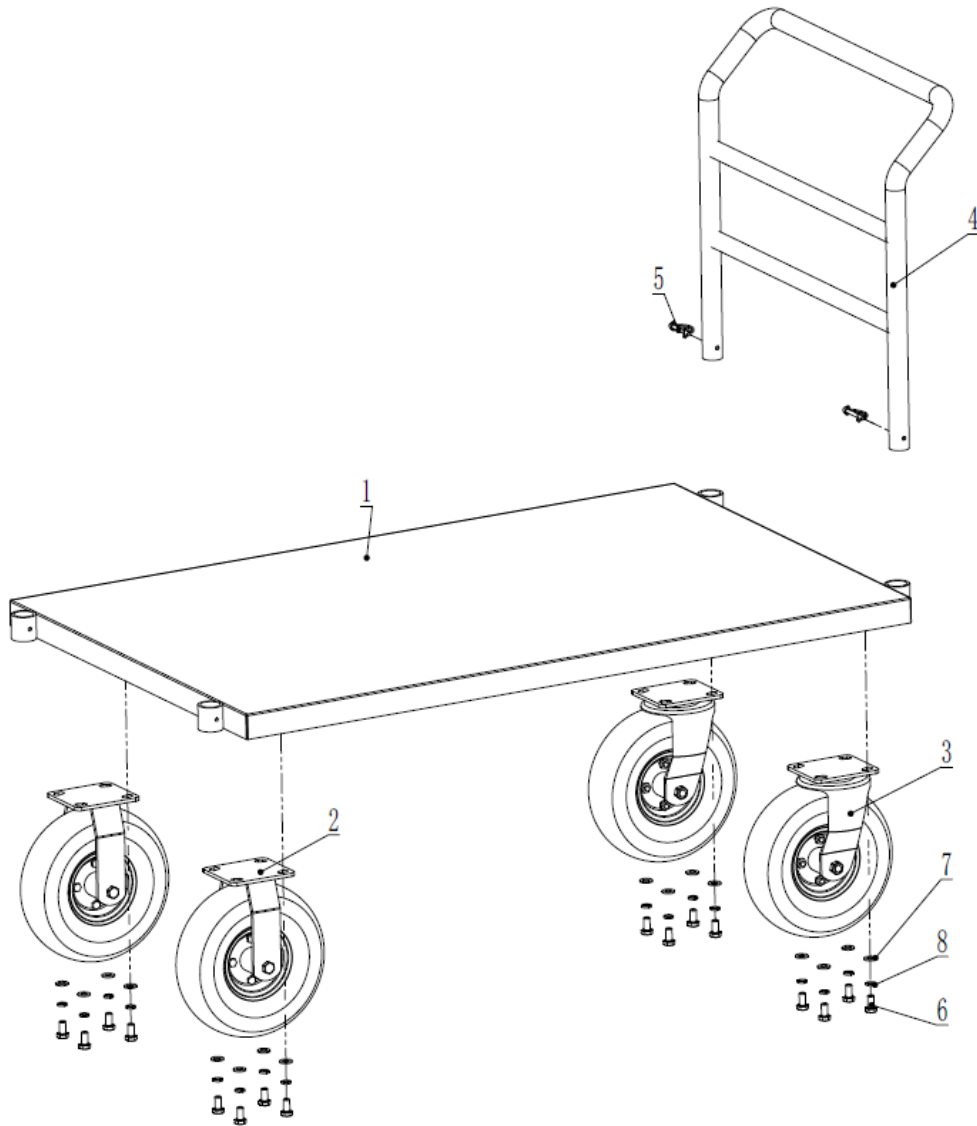

Parts List

Reference	Part Description	Quantity
1	Platform	1
2	Swivel Casters	2
3	Rigid Casters	2
4	Handle	1
5	Pins	2
6	M10x20 Bolts	16
7	Flat Washers	16
8	Spring Washers M10	16

Replacement Parts

- For replacement parts and technical questions, please call Customer Service at **1-800-222-5381**.
- Not all product components are available for replacement. The illustrations provided are a convenient reference to the location and position of parts in the assembly sequence.
- When ordering parts, the following information will be required: item description, item model number, item serial number/item lot date code, and the replacement part reference number.
- The distributor reserves the rights to make design changes and improvements to product lines and manuals without notice.

Limited Warranty

Northern Tool and Equipment Company, Inc. ("We" or "Us") warrants to the original purchaser only ("You" or "Your") that the Ironton product purchased will be free from material defects in both materials and workmanship, normal wear and tear excepted, for a period of **90 days** from date of purchase. The foregoing warranty is valid only if the installation and use of the product is strictly in accordance with product instructions. There are no other warranties, express or implied, including the warranty of merchantability or fitness for a particular purpose. If the product does not comply with this limited warranty, Your sole and exclusive remedy is that We will, at our sole option and within a commercially reasonable time, either replace the product or product component without charge to You or refund the purchase price (less shipping). This limited warranty is not transferable.

Limitations on the Warranty

This limited warranty does not cover: (a) normal wear and tear; (b) damage through abuse, neglect, misuse, or as a result of any accident or in any other manner; (c) damage from misapplication, overloading, or improper installation; (d) improper maintenance and repair; and (e) product alteration in any manner by anyone other than Us, with the sole exception of alterations made pursuant to product instructions and in a workmanlike manner.

Obligations of Purchaser

You must retain Your product purchase receipt to verify date of purchase and that You are the original purchaser. To make a warranty claim, contact Us at 1-800-222-5381, identify the product by make and model number, and follow the claim instructions that will be provided. The product and the purchase receipt must be provided to Us in order to process Your warranty claim. Any returned product that is replaced or refunded by Us becomes our property. You will be responsible for return shipping costs or costs related to Your return visit to a retail store.

Remedy Limits

Product replacement or a refund of the purchase price is Your sole remedy under this limited warranty or any other warranty related to the product. We shall not be liable for: service or labor charges or damage to Your property incurred in removing or replacing the product; any damages, including, without limitation, damages to tangible personal property or personal injury, related to Your improper use, installation, or maintenance of the product or product component; or any indirect, incidental or consequential damages of any kind for any reason.

Assumption of Risk

You acknowledge and agree that any use of the product for any purpose other than the specified use(s) stated in the product instructions is at Your own risk.

Governing Law

This limited warranty gives You specific legal rights, and You also may have other rights which vary from state to state. Some states do not allow limitations or exclusions on implied warranties or incidental or consequential damages, so the above limitations may not apply to You. This limited warranty is governed by the laws of the State of Minnesota, without regard to rules pertaining to conflicts of law. The state courts located in Dakota County, Minnesota shall have exclusive jurisdiction for any disputes relating to this warranty.



Distributed by:
Northern Tool & Equipment Company, Inc.
Burnsville, Minnesota 55306
www.northerntool.com

Made in China