



SERVICE PARTS LIST

BULLETIN NO.
54-26-2850

SPECIFY CATALOG NO. AND SERIAL NO. WHEN ORDERING PARTS		REVISED BULLETIN	DATE
M18 Fuel™ High Torque Impact Wrench w/One-Key™ - 3/4"			June 2024
CATALOG NO.	2864-20	SERIAL NO.	J40A
		WIRING INSTRUCTION See Pages 2 & 3	

FIG.	PART NO.	DESCRIPTION OF PART	NO. REQ.
1	05-81-0002	M5 x 40mm Pan Hd. ST T-20 Screw	(4)
7	02-02-0251	6.6mm Steel Ball	(1)
9	02-02-2050	3/16" Steel Ball	(28)
10	45-88-2015	Washer	(1)
11	40-50-1925	Spring	(1)
14	44-60-1960	Planet Gear Pin	(3)
15	45-88-2020	Washer	(1)
16	02-04-0375	Ball Bearing	(1)
17	-----	Gasket	(1)

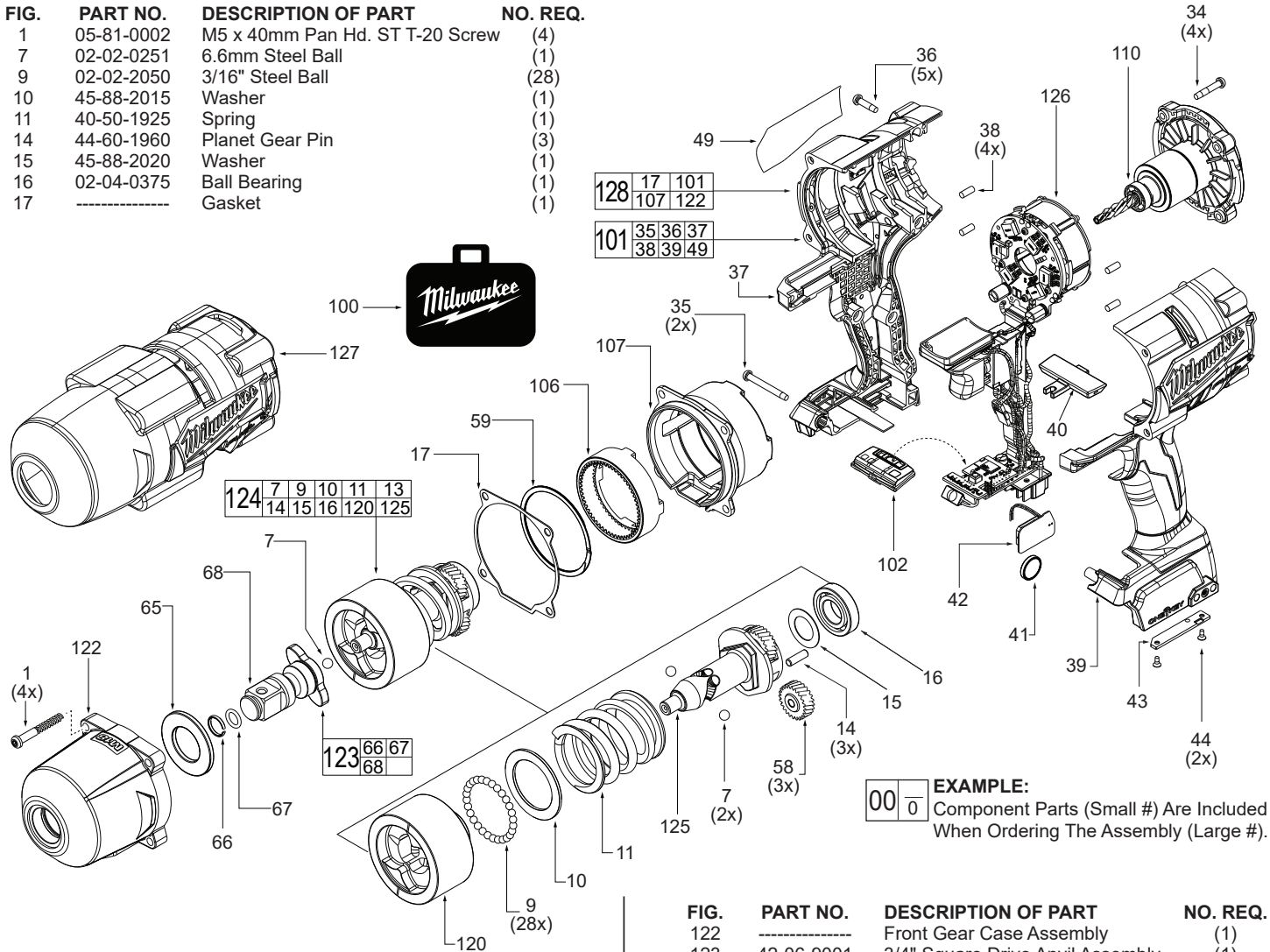

EXAMPLE:

00	0
----	---

 Component Parts (Small #) Are Included When Ordering The Assembly (Large #).

FIG.	PART NO.	DESCRIPTION OF PART	NO. REQ.
34	06-82-4001	M4 x 22mm Pan Hd. ST T-20 Screw	(4)
35	06-82-4002	M4 x 35mm Pan Hd. ST T-20 Screw	(2)
36	06-82-4003	M4 x 16mm Pan Hd. ST T-20 Screw	(5)
37	-----	Right Housing Halve - Cover	(1)
38	45-30-0255	Rubber Slug	(4)
39	-----	Left Housing Halve - Support	(1)
40	45-24-0022	Forward/Reverse Shuttle	(1)
41	-----	3V Coin Cell Battery (CR 2032)	(1)
42	22-09-2757	Coin Cell Board Assembly	(1)
43	31-15-0011	Coin Cell Cover	(1)
44	05-81-1100	M2.6 x 6mm ST Phillips Screw	(2)
49	12-20-2810	Service Nameplate	(1)
58	32-62-0500	Planet Gear	(3)
59	30-40-0052	Retaining Ring	(1)
65	45-88-4001	Front Case Washer	(1)
66	44-90-4540	C-Ring	(1)
67	34-40-1210	O-Ring	(1)
68	-----	3/4" Square Drive Anvil	(1)
100	42-55-0063	Blow Molded Carrying Case	(1)
101	-----	Housing Assembly	(1)
102	45-24-0061	Speed Selector Assembly	(1)
106	32-65-0025	Ring Gear	(1)
107	-----	Rear Gear Case	(1)
110	16-01-0400	Rotor/End Cap Assembly	(1)
120	43-81-0310	Hammer	(1)

FIG.	PART NO.	DESCRIPTION OF PART	NO. REQ.
122	-----	Front Gear Case Assembly	(1)
123	42-06-9001	3/4" Square Drive Anvil Assembly	(1)
124	14-46-3001	Gear Box Assembly	(1)
125	36-10-1011	Camshaft	(1)
126	14-20-4001	Electronics Assembly	(1)
127	49-16-2864	Rubber Boot, Accessory	(1)
128	14-46-0368	Gearcase and Handles Service Kit	(1)

LUBRICATION
 Use Type 'J' Grease, No. 49-08-4220 (1 lb. can)
 NOTE: Service grease may not be compatible with grease used during manufacturing. 90-95% of the old grease must be removed prior to any new grease being added. *See grease application to gear and hammering mechanism on page two.*

SCREW TORQUE SPECIFICATIONS				
FIG.	PART NO.	WHERE USED	SEAT TORQUE	
			(kgf-cm)	(lb-in)
1	06-82-4000	Front Gear Case	36±3	31±2
34	06-82-4004	Rotor/End Cap Assy.	16±2	14±1
35	06-82-4002	Right Housing Halve	16±2	14±1
36	06-82-4003	Right Housing Halve	16±2	14±1
44	05-81-1100	Coin Cell Cover	2.5-3.5	2-3

LUBRICATION

Use Type 'J' Grease, No. 49-08-4220 (1 lb. can)

NOTE: Service grease may not be compatible with grease used during manufacturing. 90-95% of the old grease must be removed prior to any new grease being added. See *grease application to gear and hammering mechanism on page two.*



NOTE

Regarding parts to be lubricated:
Apply a light coating of grease to all highlighted parts shown prior to installation. Reference key above for grease types.

1. Apply a light coat of grease to bushing surface of front gear case assembly.
2. Prior to installation, coat both sides of front case washer with a light film of grease.
3. Apply a light coat of grease to the shaft of anvil. Coat steel ball behind anvil with grease.
4. Place a heavy coat of grease to anvil cavity of hammer as shown. Place a light film of grease in ball groove on opposite side.
5. Coat both sides of washer with grease.

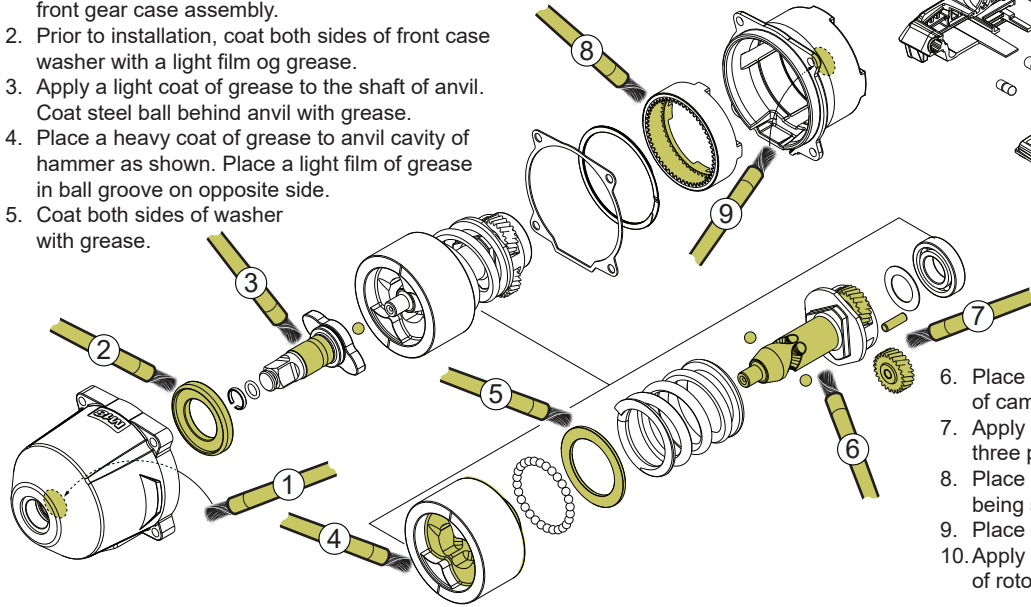

6. Place grease around shaft and in ball groove of camshaft.
7. Apply a liberal amount of grease to teeth of the three planet gears. Coat corresponding three pins.
8. Place a liberal amount of grease in the ring gear being sure all teeth are coated.
9. Place grease in back cavity of rear gear case.
10. Apply a heavy coat of grease to pinion gear teeth of rotor assembly.

WIRING

Prior to installing the electronics assembly in left housing half, PCBA Assembly must be installed in bottom cavity of front and rear gear case assemblies. Orient PCBA so wires can be inserted through slot in the bottom of rear gear case as shown.

With PCBA squarely and firmly seated, place gasket onto rear gear case. Install gear/hammer/anvil mechanisms in front gear case assembly. Carefully place those assemblies into and onto the rear gear case, trapping the PCBA inside.

