

CNP SERIES

Ultra Quiet, Compact Design Exhaust Fans



Canarm's CNP fans come complete with high efficiency motors. The CNP fans are ultra quiet, compact and easily customizable with optional accessories.

FEATURES

- Ultra quiet.
- Compact design.
- High performance and efficiency
- Holds an ETL evaluation and conforms to UL and cUL safety standards.
- 4" polymeric collar which includes a light weight built-in back draft damper.
- Elegant yet simple, low profile grille.

ACCESSORIES

- LED light kit
- Humidity sensor
- Motion sensor
- Speed controller
- Ceiling radiation damper

PERFORMANCE SPECIFICATIONS

MODEL	STATIC PRESSURE (IN W.G.)	CFM	SONES	WATTS	POWER (V/Hz)	DUCT DIAMETER
CNP80	0.1	80	0.6	18W	120/60	4"
	0.25	60	N/A			
CNP100	0.1	100	0.8	23W	120/60	4"
	0.25	97	N/A			

DIMENSIONS

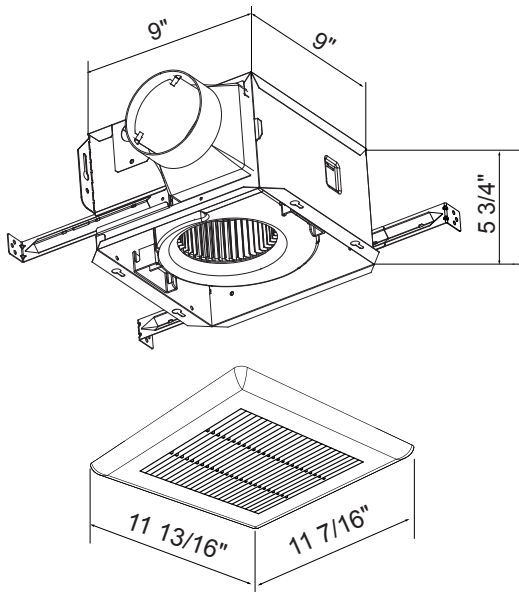

FAN CURVES

