

Clear Floor Two-Post Lifts

Installation and Operation Manual

Manual P/N 5900374 — Revision A2 — June 2024

Models:

- 12APX
- 12APX-192

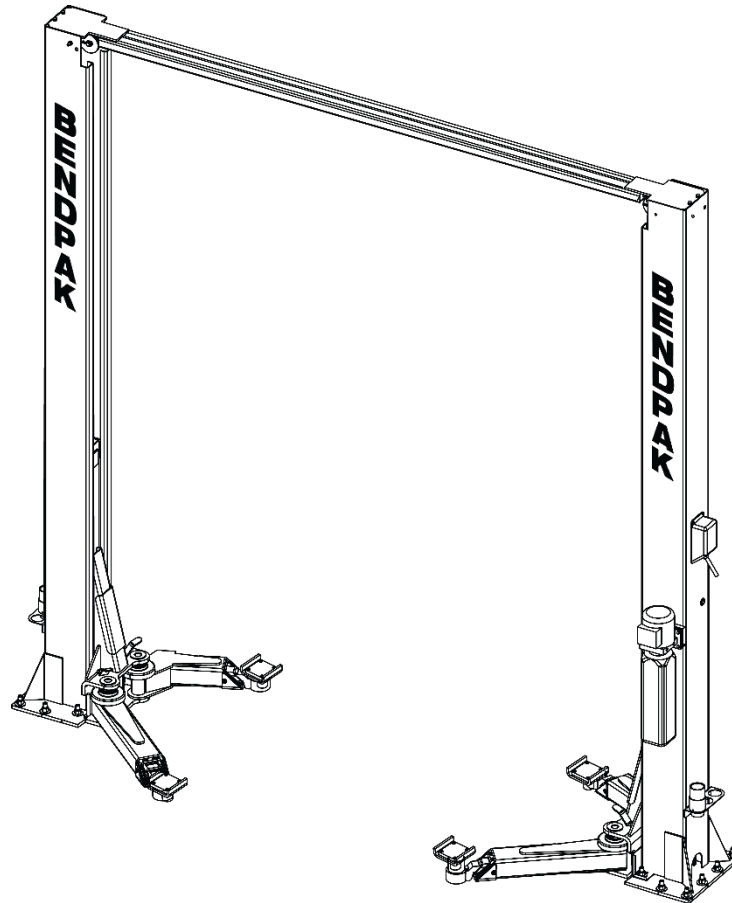

*Original instructions in
the English language.*

12APX Shown

Designed and engineered by BendPak Inc. in Southern California, USA. Made in China.

 **DANGER**

IMPORTANT Safety Instructions, save these instructions! Read the *entire* contents of this manual *before* using this product. Failure to follow the instructions and safety precautions in this manual can result in severe injury or death. Make sure all other operators also read this manual. Keep the manual near the product for future reference. *By proceeding with setup and operation, you agree that you fully understand the contents of this manual and assume full responsibility for product use.*

Manual. 12APX Series Two-Post Lifts, *Installation and Operation Manual*, Manual Part Number 5900374, Revision A2, released June 2024.

Copyright. Copyright ©2024 by BendPak Inc. All rights reserved. You may make copies of this document if you agree that: full attribution goes to BendPak Inc., you are not authorized to make changes to the content, you do not gain any rights to this content, and you will not use the copies for commercial purposes.

Trademarks. BendPak and the BendPak logo are registered trademarks of BendPak Inc. All other company, product, and service names are used for identification only. All trademarks and registered trademarks mentioned in this manual are the property of their respective owners.

Limitations. Every effort has been made to ensure complete and accurate instructions are included in this manual. However, product updates, revisions, and/or changes may have occurred since this manual was published. BendPak reserves the right to change any information in this manual without incurring any obligation for equipment previously or subsequently sold. All drawings are reference only – do not scale. BendPak is not responsible for typographical errors in this manual. You can always find the latest version of the **manual for your product on the BendPak website.**



SCAN FOR
DIGITAL PDF

Warranty. The BendPak warranty is more than a commitment to you: it is also a commitment to the value of your new product. Contact your nearest BendPak dealer or visit www.bendpak.com/support/warranty for full warranty details. Go to bendpak.com/support/register-your-product/ and fill out the online form to register your product (be sure to click **Submit**).

Safety. Your Lift was designed and manufactured with safety in mind. Your safety also depends on proper training and thoughtful operation. Do not set up, operate, maintain, or repair the Lift without reading and understanding this manual and the labels on the unit; **do not use your Lift unless you can do so safely!**

Owner Responsibility. In order to maintain your product properly and to ensure operator safety, it is the responsibility of the product owner to read and follow these instructions:

- Follow all installation, operation, and maintenance instructions.
- Make sure product installation conforms to all applicable local, state, and federal codes, rules, and regulations, such as state and federal OSHA regulations and electrical codes.
- Read and follow all safety instructions. Keep them readily available for operators.
- Make sure all operators are properly trained, know how to safely operate the unit, and are properly supervised.
- Do not operate the product until you are certain all parts are in place and operating correctly.
- Carefully inspect the product on a regular basis and perform all maintenance as required.
- Service and maintain the unit only with approved replacement parts.
- Keep the manual with the product and make sure all labels are clean and visible.
- **BendPak** makes no promises, guarantees or assurances that our products meet any state, county, federal or international mandated permit, license, code, standard, certification, or any other mandate other than what is listed or shown on BendPak website(s), or any BendPak or Ranger online or published catalog. Not all BendPak Lift models meet the standards as prescribed by ANSI/ALI ALCTV-(current edition) or ANSI/UL 201. Consult www.autolift.org for a complete list of Lift models that meet ANSI/ALI ALCTV-(current edition) or ANSI/UL 201, or contact BendPak via contact@bendpak.com. **Buyer assumes full responsibility for any state, county, federal or international mandated permit, license, code, standard, certification, or any other mandate required related to the installation and/or operation of any BendPak product.** BendPak will not be responsible for any charges, fines, liens, or other levies imposed on the Buyer related to any special or regional structural, seismic or any other building code and/or codes such as the Uniform Building Code (UBC), International Building Code (IBC), or any other state, county, federal or international mandated permit, license, code, standard, certification, or other mandate, law, rule, regulation or directive by any other agency, government, administrations, or corporations whether state, county, federal, or international mandated.

Only use the Lift if it can be used safely!

Unit Information. Enter the Model Number, Serial Number, and the Date of Manufacture from the ID label on your unit. This information is required for part or warranty issues.

Model: _____

Serial: _____

Date of Manufacture: _____

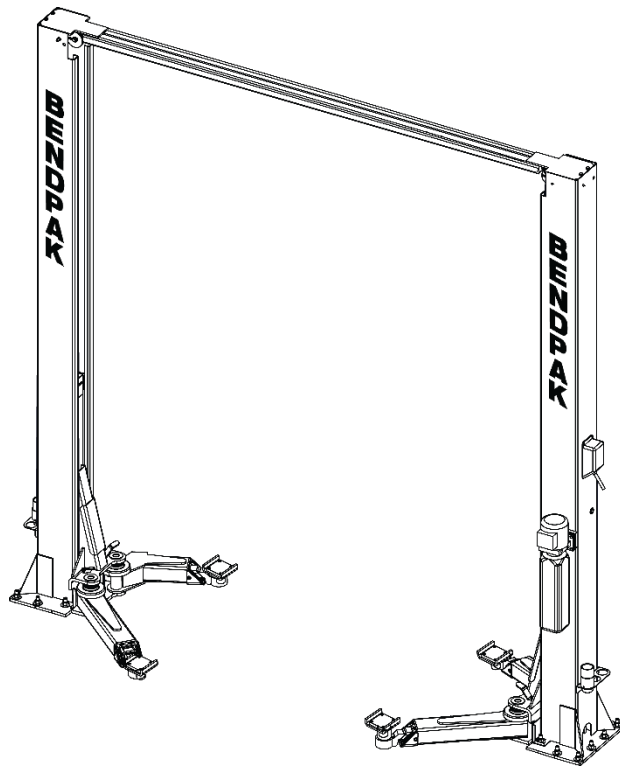

Table of Contents

Introduction	4	Maintenance	75
Shipping Information	5	Troubleshooting	80
Safety Considerations	5	Wiring Diagrams	84
Components	8	Labels	90
Specifications	9	Parts Drawings	94
Installation Checklist	11	ALI Store	107
Installation	12	Maintenance Log	108
Operation	64		

Introduction

This manual describes the four BendPak Two-Post Lift models:

- **12APX** A Two-Post Lift with an overall height of 169 in. (4,294 mm) that raises Vehicles up to 12,000 pounds (4,536 kg).
- **12APX-192** A taller version of the 12APX with an overall height of 193 in. (4,904 mm), designed to accommodate taller Vehicles while raising Vehicles up to 12,000 pounds (4,536 kg).

Both models have Overhead Assemblies and clear floors.

⚠ DANGER Be very careful when installing, operating, maintaining, or repairing this equipment; failure to do so could result in property damage, product damage, injury, or (in very rare cases) death. Make sure only authorized personnel operate this equipment. An authorized technician must perform all repairs. Do not make modifications to the unit; this voids the warranty and increases the chances of injury or property damage. Make sure to read and follow the instructions on the labels on the unit.

This manual is mandatory reading for all users of 12APX Series Two-Post Lifts, including anyone who installs, operates, maintains, or repairs them. Always keep this manual on or near the equipment.

Technical support and service is available from your dealer, on the Web at bendpak.com/support, by email at support@bendpak.com, or by phone at **(800) 253-2363**, option 7, then 4.

Online chat is also available at www.bendpak.com click the chat icon.



Scan this QR Code for up-to-date information and videos on the 12APX Lift series.



Shipping Information

Your equipment was carefully checked before shipping. Nevertheless, you should thoroughly inspect the shipment **before** you sign to acknowledge that you received it.

When you sign the bill of lading, it tells the carrier that the items on the invoice were received in good condition. **Do not sign the bill of lading until after you have inspected the shipment.** If any of the items listed on the bill of lading are missing or damaged, do not accept the shipment until the carrier makes a notation on the bill of lading that lists the missing or damaged goods.

If you discover missing or damaged goods **after** you receive the shipment and have signed the bill of lading, notify the carrier at once and request the carrier to make an inspection. If the carrier will not make an inspection, prepare a signed statement to the effect that you have notified the carrier (on a specific date), and that the carrier has failed to comply with your request.

It is difficult to collect for loss or damage after you have given the carrier a signed bill of lading. If this happens to you, file a claim with the carrier promptly. Support your claim with copies of the bill of lading, freight bill, invoice, and photographs, if available. Our willingness to assist in helping you process your claim does not make us responsible for collection of claims or replacement of lost or damaged materials.

Safety Considerations

Read this entire manual carefully before using your new product. Do not install or operate the product until you are familiar with all operating instructions and warnings. Do not allow anyone else to operate the product until they are familiar with all operating instructions and warnings.

 **WARNING California Proposition 65.** This product can expose you to chemicals including styrene and vinyl chloride which are on the list of over 900 chemicals identified by the State of California to cause cancer, birth defects or reproductive harm. Always use this product in accordance with BendPak's instructions. For more information, visit www.p65warnings.ca.gov.

Important Safety Information

When using this equipment, basic safety precautions should always be followed, including:

1. Read all instructions. Use only as described in this manual.
2. Only operate your Lift between temperatures of 41°F to 104°F (5°C to 40°C).
3. Make sure all operators read and understand this *Installation and Operation Manual*. **Keep the manual near the Lift at all times.** The Lift should only be operated by authorized personnel. Keep children and untrained personnel away from the Lift.
4. BendPak recommends referring to the ANSI/ALI ALIS Standard *Safety Requirements for Installation and Service* for more information about safely installing, using, and servicing your Lift.
5. The Lift should only be operated by authorized personnel. Keep children and untrained personnel away from the Lift.
6. Do not make any modifications to the Lift; this voids the warranty and increases the chances of injury or property damage. Use only factory-approved attachments.
7. Do not use the Lift while tired or under the influence of drugs, alcohol, or medication.
8. Do not touch hot parts; you could be burned. Always use care with the equipment.

-
9. Do not operate equipment with a damaged cord or if the equipment has been dropped or damaged – until a qualified service person has examined it.
 10. Do not let a cord hang over the edge of a table, bench, or counter or come in contact with hot manifolds or moving fan blades. Loop the power cord around equipment when storing.
 11. If an extension cord is necessary, a cord with a current rating equal to or greater than that of the equipment should be used. Cords rated for less current than the equipment may overheat. Care should be taken to arrange the cord so that it will not be tripped over or pulled out.
 12. Always unplug equipment from electrical outlets when not in use. Never use the cord to pull the plug from the outlet. Grasp plug and pull to disconnect.
 13. To reduce the risk of a fire, do not operate equipment in the vicinity of open containers of flammable liquids (such as fuel, thinners, etc.).
 14. Adequate ventilation should be provided when working on operating internal combustion engines.
 15. Keep hair, loose clothing, fingers, and all parts of the body away from moving parts.
 16. To reduce the risk of electric shock, do not use the unit on wet surfaces or expose to rain.
 17. Always wear safety glasses! Everyday glasses only have impact resistant lenses, they are not safety glasses.
 18. 12APX Series Lifts are Two-Post Service Lifts. *Use them only for their intended purpose.*
 19. You must wear OSHA-approved (publication 3151) personal protective equipment **at all times** when installing, using, maintaining, or repairing the Lift. Leather gloves, steel-toed work boots, eye protection, back belts, and hearing protection are **mandatory**.
 20. **Never** exceed the rated capacity of the Lift.
 21. When the Lift is in use, keep hands and all body parts well away from it.
 22. Keep loads balanced on the Lift Arm Assemblies. Clear the area immediately if a Vehicle is in danger of falling off the Lift.
 23. Modifications void the warranty and increases the chances of injury or property damage. *Do not modify any safety-related features in any way.*
 24. The Lift uses electrical energy; if your organization has Lockout/Tagout policies, make sure to implement them after connecting the Lift to a power source.
 25. When handling the Hydraulic components, **always wear safety gloves!** In rare cases, a needle-like stream of Hydraulic Fluid (even at low pressure) can penetrate fingers, hands, or arms. Such a puncture can feel like a bite, electric shock, or a prick. While it may seem like a minor issue, any amount of Hydraulic Fluid injected into the human body is a serious issue. Anyone suffering such a puncture wound should be **immediately** taken as an emergency to the hospital to determine the extent of the injury. Explain the circumstances of the injury to the attending physician, including what type of Hydraulic Fluid was involved. Do not assume a puncture wound that could have been caused by Hydraulic Fluid is a minor issue; it could be life-threatening.
 26. Make a visual inspection of the Lift before using it. Do not use the Lift if you find any missing or damaged parts. Instead, take it out of service, then contact an authorized repair facility, your distributor, or BendPak at **(805) 933-9970** option 7 then 5, or email support@bendpak.com.
 27. BendPak recommends making a **thorough** inspection of the Lift at least once a year. Replace any damaged or severely worn parts, decals, or warning labels.

Symbols

Following are symbols used in this manual:



DANGER Calls attention to a hazard that **will** result in death or injury.



WARNING Calls attention to a hazard or unsafe practice that **could** result in death or injury.



CAUTION Calls attention to a hazard or unsafe practice that could result in personal injury, product damage, or property damage.



NOTICE Calls attention to a situation that could result in product or property damage.

Liability Information

BendPak assumes **no** liability for damages resulting from:

- Use of the equipment for purposes other than those described in this manual.
- Modifications to the equipment without prior, written permission from BendPak.
- Injury or death caused by modifying, disabling, overriding, or removing safety features.
- Damage to the equipment from external influences.
- Incorrect operation of the equipment.

Components

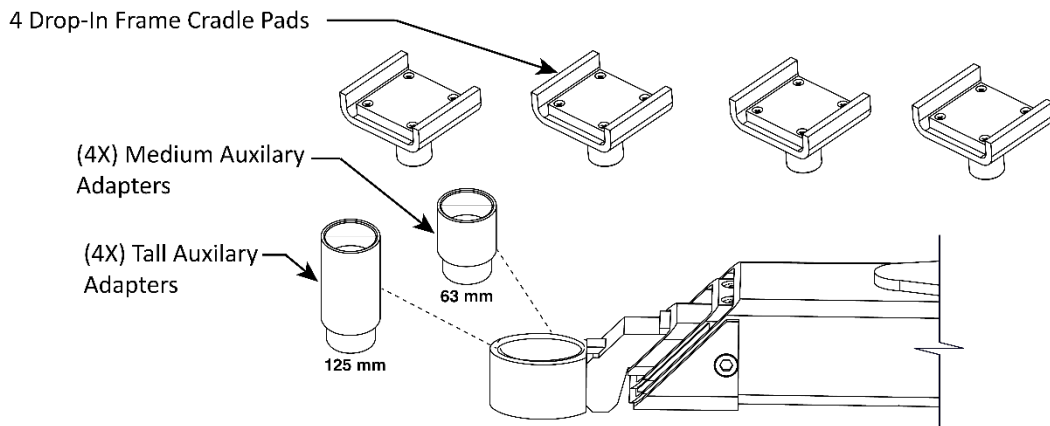
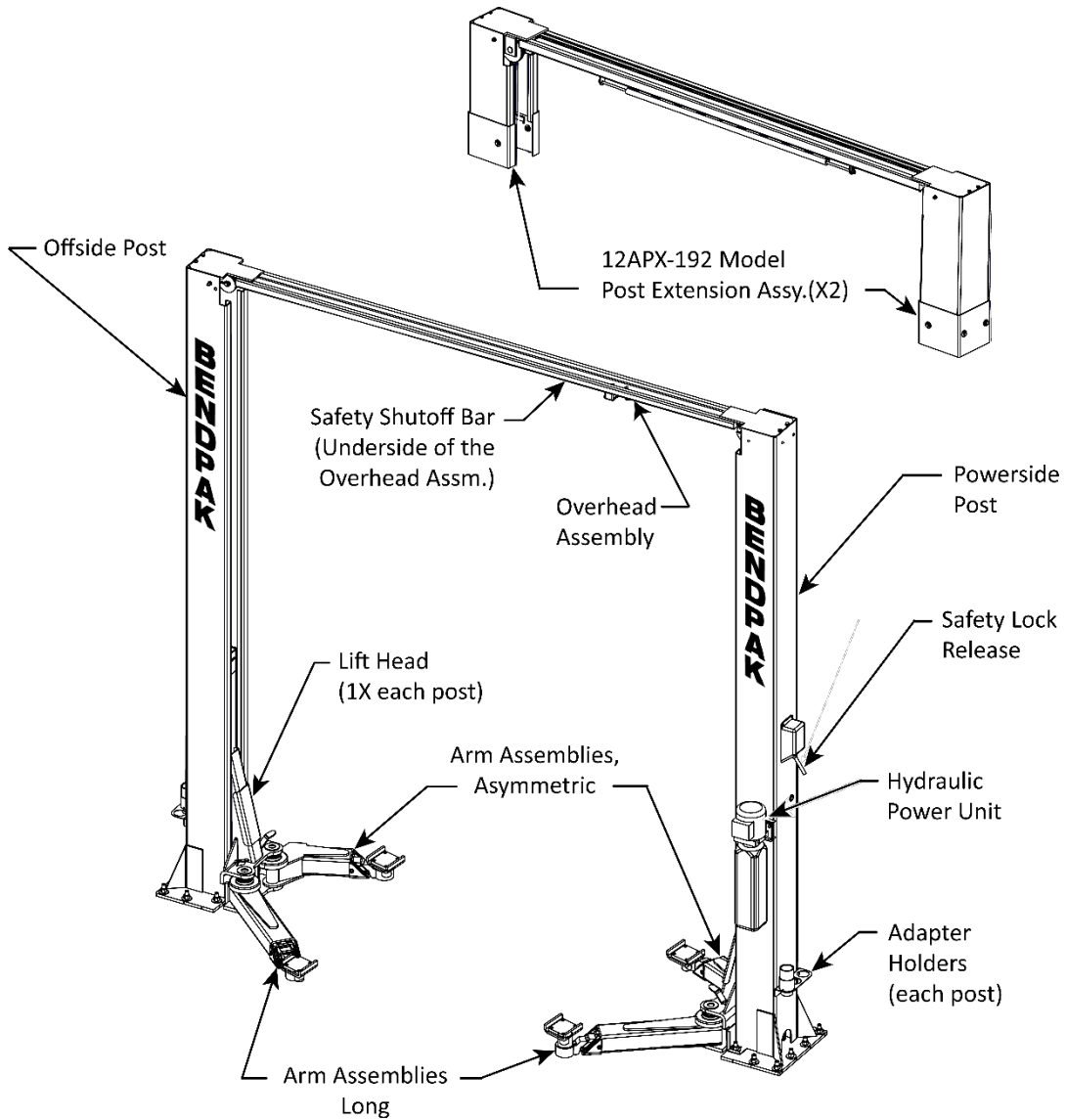

Not all components shown. Models with extensions are taller. Reference only – do not scale.

Specifications

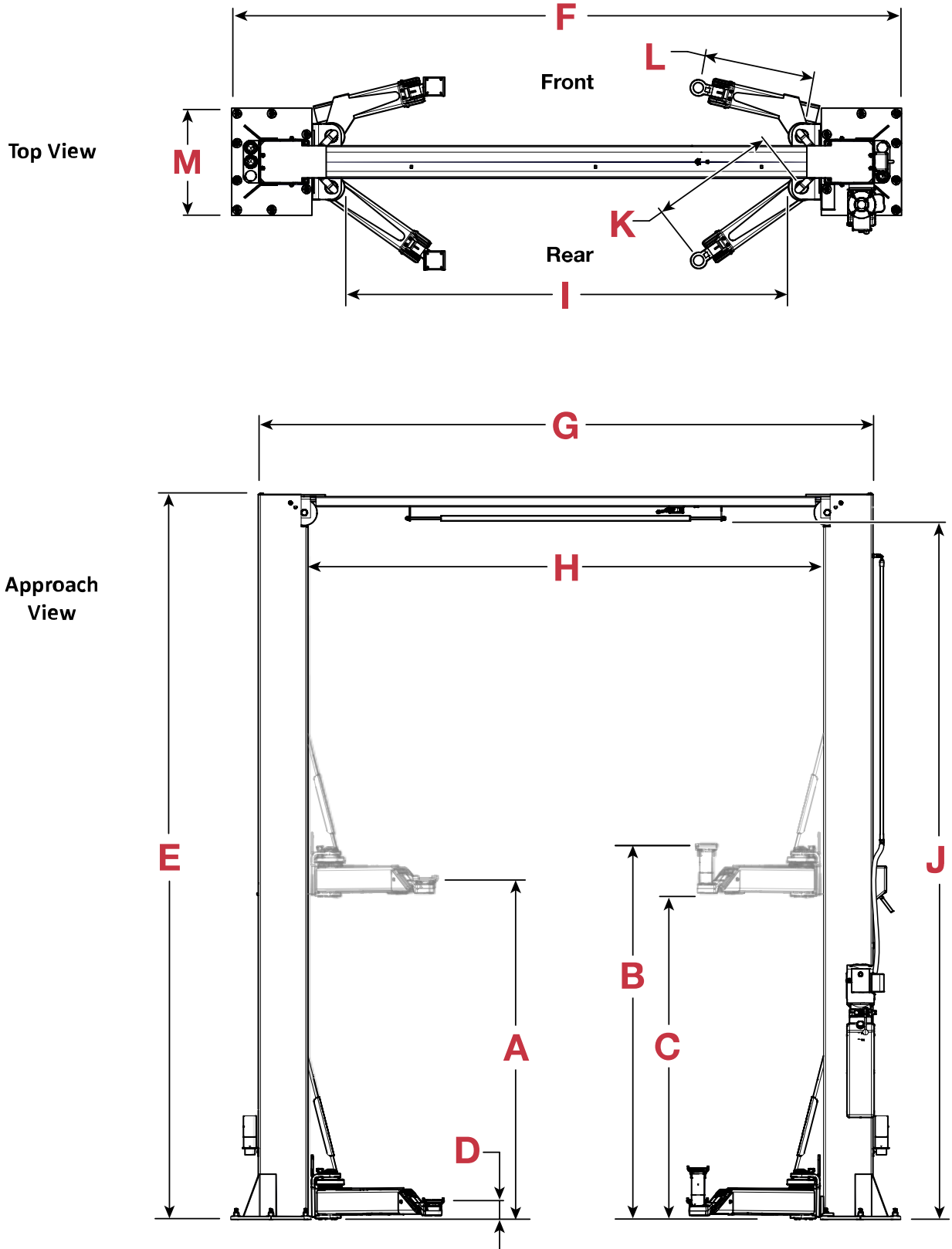

Reference only – do not scale.

Model	12APX	12APX-192
Lifting Capacity	12,000 lbs. (5,443 kg)	
Max. Capacity — Front Axle	6,000 lbs. (2,722 kg)	
Max. Capacity — Rear Axle	6,000 lbs. (2,722 kg)	
Max. load per Lift Arm	3,000 lbs. (2,268 kg)	
A – Max. Lifting Height w/ Pad (Top Lock) ¹	79 in. (2,005 mm)	
B – Max. Lifting Height w/Adapters (Top Lock) ²	86.25 in. (2,193 mm)	
C – Max. Rise (No lock engaged)	76 in (1,929 mm)	
D – Min. Height w/ Pad	4.5 in. (113 mm)	
E – Overall Height	169 in. (4,294 mm)	193 in. (4,904 mm)
F – Width Overall	156 in. (3,959 mm)	
G – Outside Posts	143 in. (3,632 mm)	
H – Inside Posts	120 in. (3,047 mm)	
I – Drive-Thru Width	103 in. (2,616 mm)	
J – Floor to Top Switch	162.5 in. (4,128 mm)	186.50 in. (4,738 mm)
K – Rear Arm Reach (min. – max.) ³	29.50 in. (745 mm) min. to 60 in. (1,524 mm) max.	
L – Front Arm Reach (min. - max) ³	26 in. (660 mm) min. to 55.25 in. (1,404 mm) max.	
M – Base Plate Width	25 in. (634 mm)	
Operating Pressure at Maximum Load	2,220 psi	
Time to Full Rise	≈ 68 seconds	
Motor Power Consumption Range (typical) ⁴	208 to 230 VAC, 50/60 Hz, 1 Ph, 5 HP, Approx. 23 Amps	
Hydraulic Fluid Required	3.6 gallons (13.6 Liters)	
Sound Pressure	<70 dB	

¹ *Lifting Height w/Pad* is the maximum lifting height at top lock with Pad only and no adapter(s).

² *Maximum Lifting Height w/Adapters* is the maximum lifting height with both tall and medium Adapters installed.

³ Lift Arms are measured from the Lift Arm's axis of rotation to the Frame Cradle Pad mounting pin center.

⁴ Special voltages available upon request.

Specifications subject to change without notice.

Installation Checklist

Following are the steps needed to install a 12APX Series Two-Post Lift; perform them in this order.

- 1. Review the Safety Rules.
- 2. Make sure you have the necessary tools.
- 3. Plan for Electrical Work.
- 4. Review the installation orientation and required clearances around the Lift.
- 5. Select the Installation Location.
- 6. Install the Safety Assemblies and position the Safety Cable.
- 7. Put Equalizing Cables into position.
- 8. Add Extension Pieces (12APX-192 Model only).
- 9. Learn about Liquid Thread Sealant.
- 10. Learn about Hydraulic Fluid contamination.
- 11. Read Hydraulic System Warnings
- 12. Route the Hydraulic Hoses.
- 13. Create Chalk Line Guides for the Posts.
- 14. Raise and anchor the Posts.
- 15. Prepare and install the Overhead Assembly and Safety Shutoff Bar.
- 16. Install the Limit Switch.
- 17. Complete the Equalizing Cables installation.
- 18. Mount the Power Unit (*do not connect to power*).
- 19. Route and install the Safety Lock Cable.
- 20. Connect the Hydraulic Hoses.
- 21. Install the Lift Arm Assemblies.
- 22. Install the Double Threaded Rod.
- 23. Level the Lift.
- 24. Contact the Electrician.
- 25. Connect the Overhead Limit Switch (Electrician Required)
- 26. Connect the Power Unit (Electrician Required).
- 27. Install the Power Disconnect (Electrician required).
- 28. Install a Thermal Disconnect if required by local code (Electrician required).
- 29. Lubricate the Lift.
- 30. Review the Final Checklist.
- 31. Test the Lift
- 32. Leave the Manual at the Lift for the Owner/Operator.

Installation

The installation process includes multiple steps. Perform them in the order listed.

⚠ WARNING Use only the factory-supplied parts shipped with your Lift. If you use attachments, accessories, or configuration modifying components that are in the path and/or affect the operation of the equipment, affect the equipment's electrical listing, or affect the intended Vehicle accommodation, and if they are not certified for use with this Lift, then you void the warranty of the Lift as well as compromising the safety of everyone who sets up or uses the Lift. If you are missing parts, visit [BendPak.com/Support](https://www.bendpak.com/Support), email support@bendpak.com or contact BendPak technical support by phone at **(800) 253-2363**, option 7 then 4. Online chat is also available at www.bendpak.com click the chat icon. 

Review the Safety Rules

When installing a Lift, your safety depends on proper training and thoughtful operation. BendPak recommends referring to the ANSI/ALI ALIS Standard *Safety Requirements for Installation and Service* for more information about safely installing, using, and servicing your Lift.

⚠ WARNING Do not install this equipment unless you have automotive lift installation training. Always use proper lifting tools, such as a Forklift or Shop Crane, to raise heavy components. Do not install this equipment without reading and understanding this Manual and the Labels on the unit.

⚠ WARNING Many of the Lift components are heavy and awkward to work with. Installation should be accomplished by competent personnel ensuring all heavy components are properly rigged and balanced for lifting. Installation personnel should have knowledge, training, and experience in lifting, rigging, and securing heavy objects.

⚠ WARNING You must always wear appropriate protective equipment during installation: leather gloves, steel-toed work boots, eye protection, back belts, and hearing protection.

Gather Your Tools

You may need some or all the following tools:

- Rotary hammer drill (or similar)
- 3/4 in. carbide bit (conforming to ANSI B212.15)
- Hammer
- Four-foot level
- Open-end wrench set, SAE, and metric
- Socket and ratchet set, SAE, and metric
- Hex-key wrench set
- Crescent and pipe wrenches
- Red and White Lithium Grease
- Crowbar
- Chalk line
- Medium-sized flat screwdriver
- Tape measure, 25 feet or more
- Needle-nose pliers
- Forklift or Hoist/Crane
- Two 12-foot ladders
- Two sawhorses
- Torque wrench

Prepare for Electrical Work

You will need to have a licensed Electrician available at some point during the installation.

⚠ DANGER All wiring must be performed by a licensed Electrician in accordance with applicable national, state, and local electrical codes, rules, and regulations, such as state and federal OSHA regulations and electrical codes.

NOTICE Notify your Electrician in advance so they arrive prepared with the items required to connect to the facility's power system, or an appropriate power cord with plug to connect to a power source, and a Power Disconnect Switch. A Thermal Disconnect Switch may be required by local electrical code. **These items are not supplied with the Lift.**

The Electrician needs to:

- **Connect to the VAC power source.** The Power Unit comes with a pigtail for wiring to a power source. Have your Electrician connect a power cord with plug to the electrical box on the Lift for connection to a power outlet or have them wire it directly into the electrical system at the Lift location. The Lift's Power Unit must be protected by an appropriate circuit breaker.
- **Connect the Limit Switch wiring to the Power Unit.** The Limit Switch must be wired to the Power Unit. The required 2-conductor cable is included with the Lift.
- **Install a Power Disconnect Switch.** A Power Disconnect Switch is used to shut down the Lift in the event of an electrical circuit fault, emergency, or when the Lift is being serviced. Refer to [Installing a Power Disconnect Switch](#) for more information.
- **Install a Thermal Disconnect Switch**, if required by local electrical code. Refer to [Installing a Thermal Disconnect Switch](#) for more information.

Review the Installation Orientation

Keep these factors in mind when deciding how to orient the Lift:

- The first thing to figure out is which direction you will be driving the Vehicles in, called the **Approach**.
 - In most cases there is a driveway on one side and a wall on the other side. The driveway is your Approach. This makes the wall side the Front of the Lift and the driveway side the Rear of the Lift.
 - If both sides are open, decide which way you will be driving Vehicles onto the Lift. This is the Approach; the drive-**on** side is the Rear of the Lift and the drive-**off** side is the Front.
- While the Power Unit **must** be installed on the Power Side Post, that Power Side Post may be mounted on either side of the Lift. You can identify the Power Side Post by the Mounting Bracket to which the Power Unit attaches. Refer to the figures below.

⚠ CAUTION

When installing the Overhead Assembly, always orient the assembly to place the Limit Switch on the Power Unit side of the Lift.

**Top View
Approach Side**

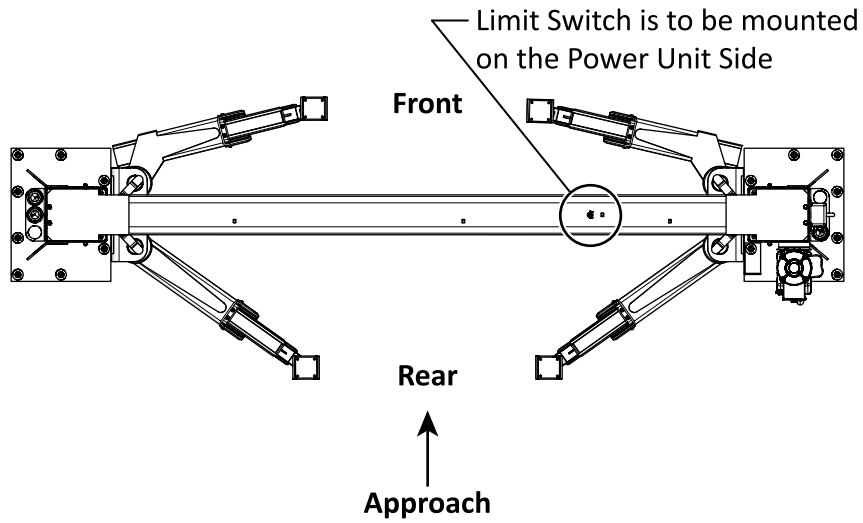

**Top View
Power Unit
Opposite Approach**

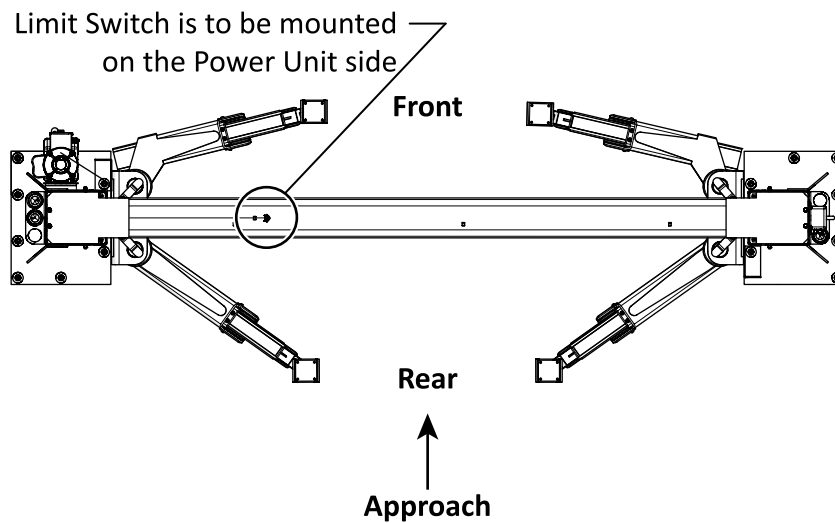

Check the Clearances

Clearance around and above the Lift is **required for safety**. Refer to the figures below.

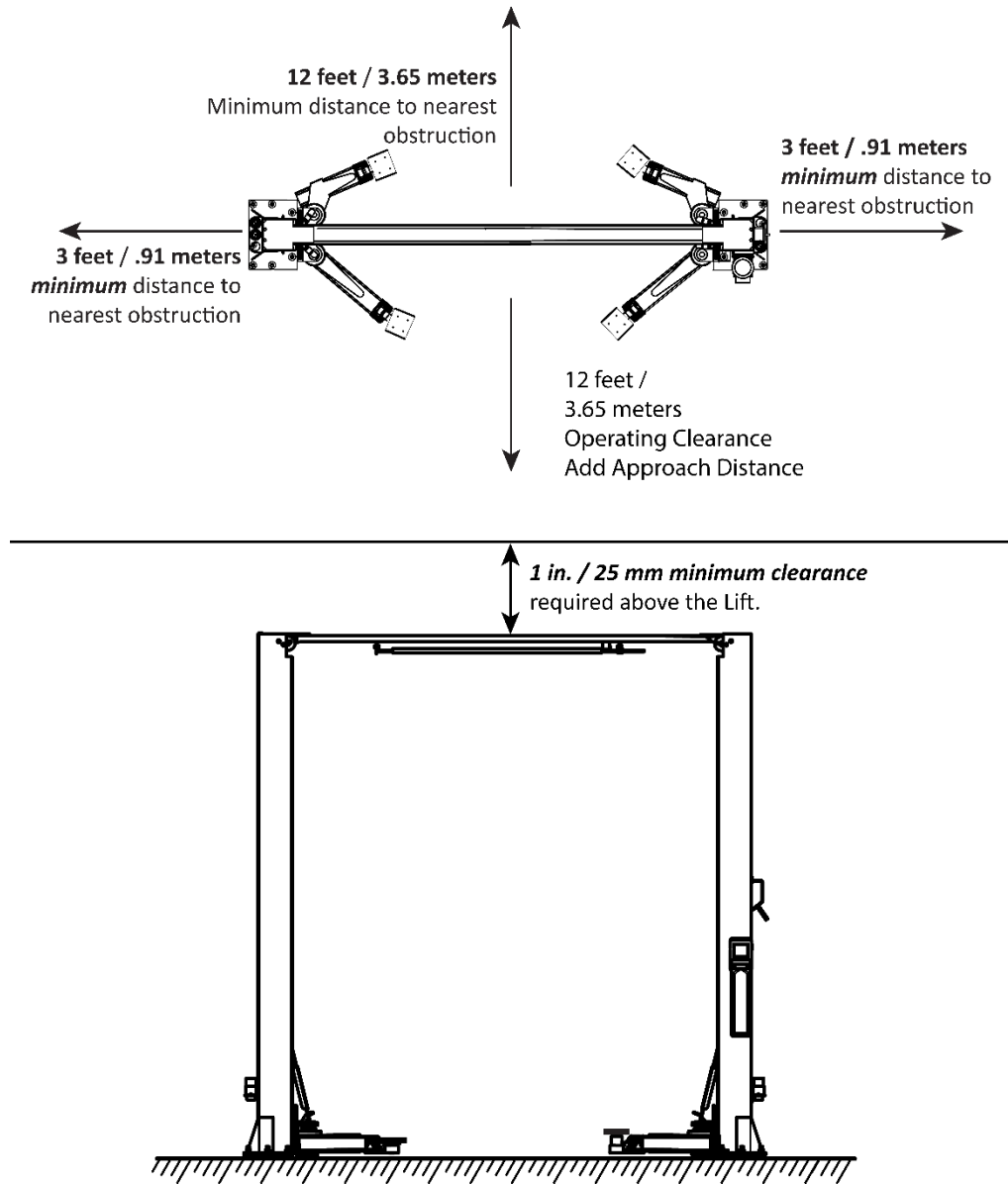

Figures are not to scale. Not all components shown. Sufficient distance WILL be required on the Front and/or Rear to allow Vehicles to be driven in or backed out from these directions.

Select a Location

When selecting the location for your Lift, consider the following:

- **Architectural plans.** Consult the architectural plans for the desired location. Make sure there are no contradictions between what you want to do and what the plans allow.
- **Available space.** Make sure there is enough space for the Lift: front, back, sides, and **above**. Refer to **Specifications** for exact measurements. Check for overhead obstructions such as building supports, heaters, lights, electrical lines, low ceilings, and/or other obstacles.
- **Power.** You need an appropriate VAC power source for the Lift's Power Unit.
- **Outdoor installations.** 12APX Series Two-Post Lifts are approved for indoor installation and use only. **Outdoor installation is prohibited.**
- **Floor.** Only install the Lift on a flat, concrete floor; do not install on asphalt or any other surface. The surface must be level; do not install if the surface has a slope greater than or equal to 3°.

 **WARNING** Installing your Lift on a surface with more than three degrees of slope could lead to injury or even death. Only install your Lift on a level floor (defined as no more than 3/8 in. (9.5 mm) difference over the installation area). If your floor is not level, consider making the floor level or using a different location.

 **DANGER** **Risk of explosion:** This equipment has internal arcing or parts that may spark and should not be exposed to flammable vapors. The Power Unit's motor should not be located in a recessed area or below floor level. Mount the motor at least 18 in. (457 mm) above the floor. Never expose the motor to rain or other damp environments; damage to the motor caused by water is not covered by the warranty.

- **Concrete specifications.** The concrete must be steel reinforced, a minimum 6 in. (150 mm) thick, 3,000 PSI minimum compressive strength, and cured for a minimum of 28 days. Do not install the Lift on cracked or defective concrete. Anchor Bolts must be more than six inches from cracks and expansion joints in the concrete or from a wall.

 **CAUTION** BendPak Lifts are supplied with installation instructions and concrete anchors that meet the criteria set by the latest version of the American National Standard in Automotive Lifts – Safety Requirements for Construction, Testing, and Validation in., ANSI/ALI ALCTV. Consult with an expert for any special regional structural and/or seismic anchoring requirements specified by any other agencies and/or codes such as the Uniform Building Code (UBC) and/or International Building Code (IBC).

Check your floor for the possibility of it being a post-tension slab. In this case, contact the building architect **before** drilling. Using ground penetrating radar may help you find tensioned steel.

 **WARNING** Cutting through a tensioned cable can result in injury or death. Do not drill into a post-tension slab unless the building architect confirms you are **not** going to hit tensioned steel, or you have located it using ground penetrating radar. **If colored sheath comes up during drilling, stop drilling immediately.**

- **Unloading the components.** Unload the Lift components as close to the installation location as possible. The Lift includes several heavy pieces, so the closer you unload them to the installation location, the better.

⚠ WARNING Some Lift components are very heavy; if handled incorrectly, they can damage materials they are placed on like tile, sandstone, and brick. Try to handle the Lift components just twice: once when delivered and once when moved into a suitable position. You must have a Forklift or Shop Crane to move some of the Lift components into position. **Use care when moving Lift components.**

Install the Safety Assemblies and Position the Safety Lock Cable

Leaving both Lift Posts flat on the ground with access to the inside of the Post will ease the Safety Lock installation and threading of the Safety Lock Cable into position. This procedure is intended to leave the cable coiled at the top of the Off Side Post, ready for routing after the Posts are standing. This position will also make it easier to put the Equalizing Cables into position.

12APX Series Lifts have two Safety Assemblies: one on the Power Side Post (above the Power Unit) and the other on the Off Side Post at the same height.

The two Safety Assemblies engage the Lift head and prevent it from lowering. The Safety Release mechanism allows the Lift Head to move past the Safety Locks and lower to the ground. The Safety Assemblies must be disengaged **at the same time** so that both Lift Heads lower together. To accomplish this, the two Safety Assemblies are connected to each other via a Safety Lock Cable, which is routed through the Lift Posts and the Overhead Assembly.

The following illustrations display the Off Side and Power Side Safety Mechanisms.

Off Side Safety: Similar to the Power Side Safety, except that it does not have a Safety Lock Release Handle.

Power Side Safety: The Power Side Safety includes a Safety Lock Release Handle and spring, which is pushed down and used to disengage the Safety Locks when lowering the Lift.

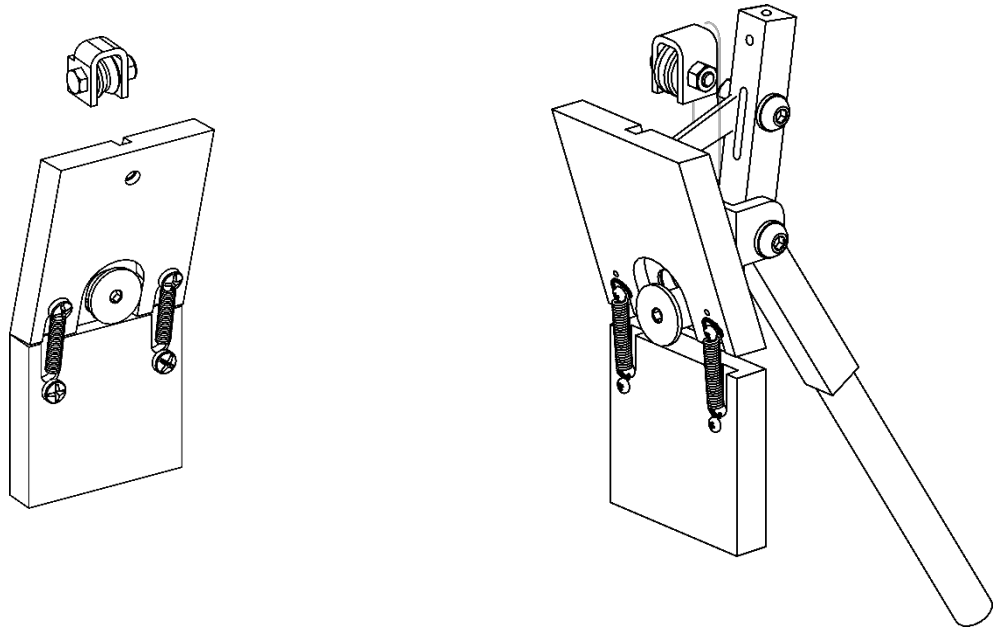

To assemble and install the two Safety Assemblies and pre-position the safety release cable:

1. Put both Posts either flat on the ground or elevated on a sawhorse or similar. The **insides** of the Posts must be accessible, facing up.
2. Slide the Lift Heads away from the bottom of both Posts. Far enough to clear the Latch Support Plate and provide room to work.

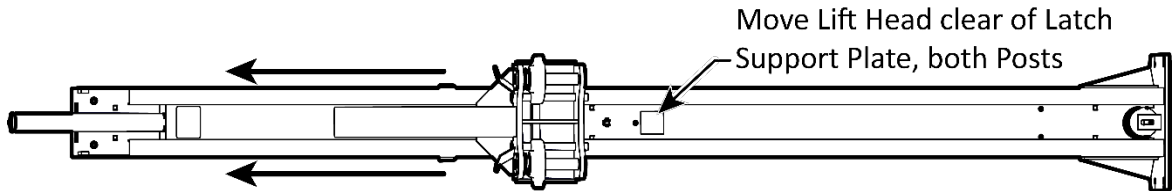
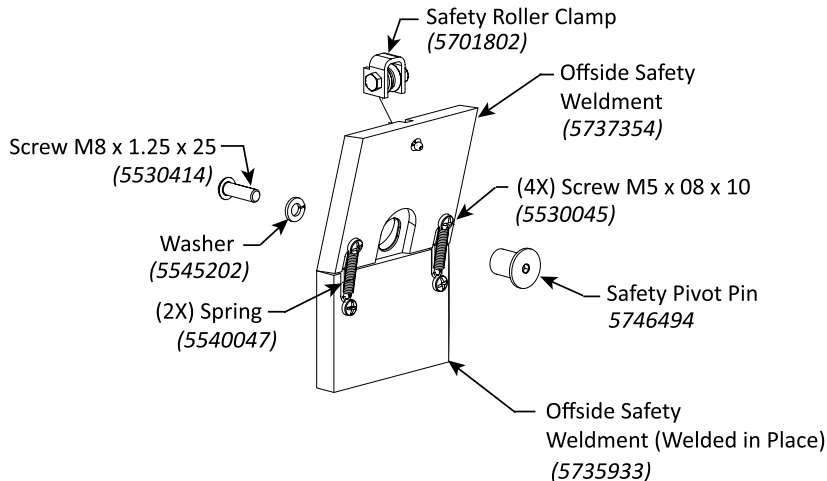
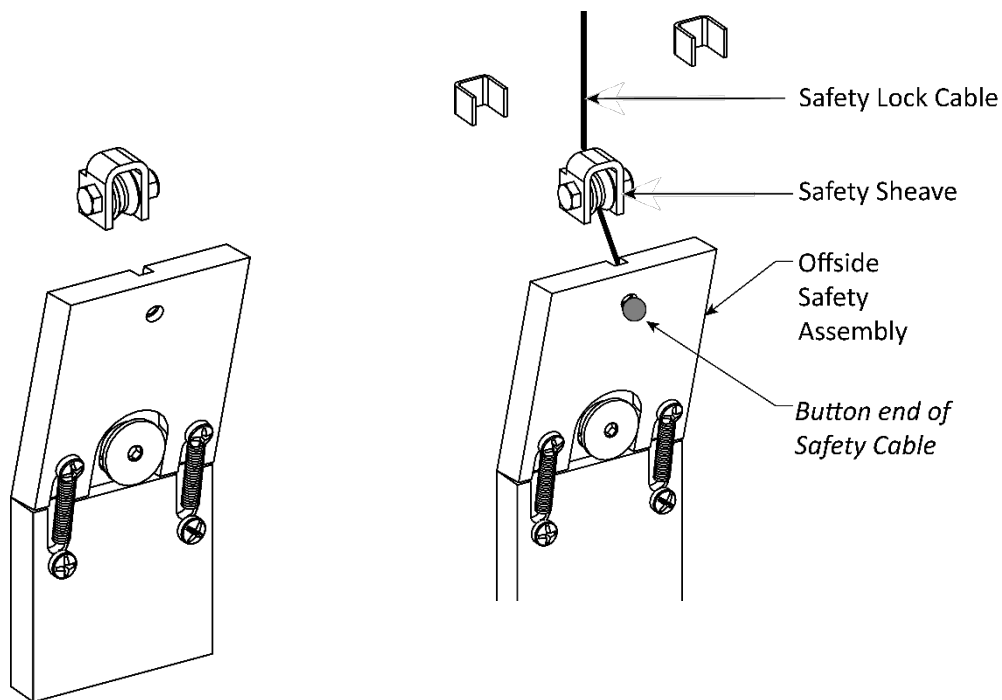

Illustration above is a top view looking at the inside of the Lift Post. Not to Scale. Some components removed for clarity.

3. **Begin on the Off Side Post**, retrieve the Off Side Safety Block (5737354), two extension springs (5540047), four M6 x 20 machine screws (5530045) and the Pivot Pin (5746494) from the Parts Bag. Overlap the Safety Block over the Latch Support Plate welded to the Off Side Lift Post. Then attach the extension Springs. Overlapping these parts will ease the Extension Spring installation. Then move the Safety Block to overlap the Latch Support Plate and secure using the Safety Pivot Pin as shown below.



Not to scale. Components removed for clarity.



Reference only – do not scale.

4. Locate the Safety Lock Cable. This is a long, thin Wire Rope Cable with a Button swaged onto one end and nothing on the other end. Thread the cable through the Off Side Safety Block as shown above. *Part Number and Cable length varies based on Lift Model.*

Model	Part Number	Safety Cable Dia. and Length
12APX	5595759	Ø1.8 x 8,850 mm
12APX-192	5595761	Ø1.8 x 10,070 mm

Thread the remainder of the Safety Lock Cable under the Safety Cable Sheave and Lift Head, then up to the top of the Off Side Post. **Coil the cable and secure with tape or a Zip Tie at the top of the Off Side Lift Post until called for later in the assembly.**

5. **Move to the Power Side Post**, Retrieve the Power Side Safety Weldment (5601905), the two extension springs (5540047) and four BHPS M5 x 0.8 x 10 machine screws (5530045), then attach over the Safety Latch Support Block that is welded inside the Post, as shown next. Attach the Safety Pivot Holder (5700404) to the Power Side Post, as depicted in the next step.

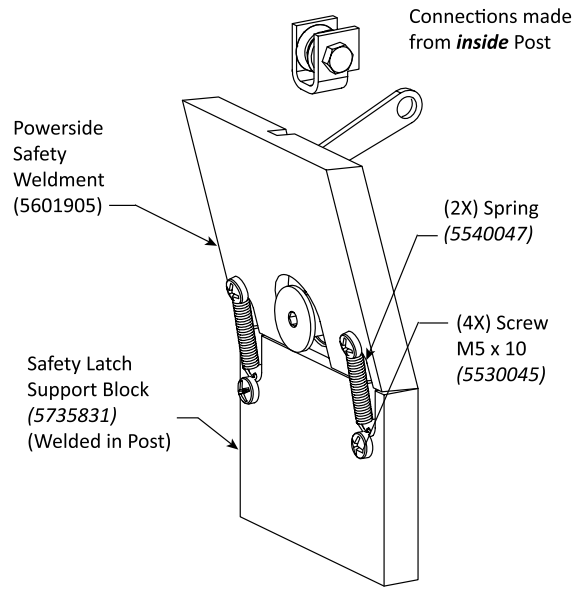

Reference only – do not scale.

6. Connect the Pivot Pin and Safety Pivot Holder using the M8 x 25 Machine Screw through the Power Side Post.

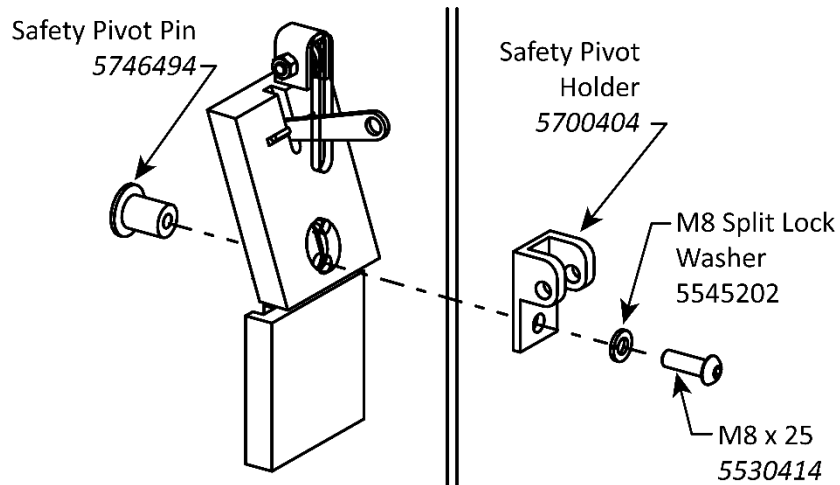

7. After the Safety Pivot Holder is in place, attach the Safety Release Handle (5761017) as depicted below.

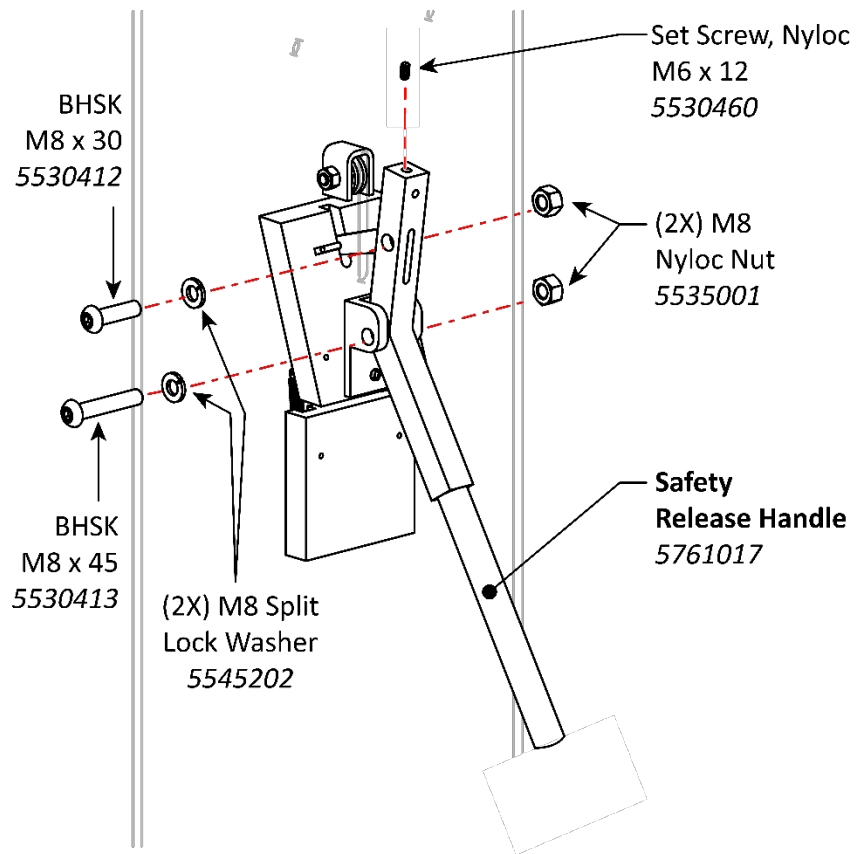

Reference only – do not scale.

Put the Equalizing Cables into Position

It is much easier to put the Equalizing Cables into position **before** you stand up the Posts. Note that this is not a full install of the Equalizing Cables, just putting them into position and looping the excess at the top of the Post secured with a Zip Tie or Tape.

NOTICE The two Equalizing Cables are the same length.

CAUTION BendPak recommends wearing safety gloves when handling the Equalizing Cables. The following graphic provides an overview of the Equalizer Cable routed into position.

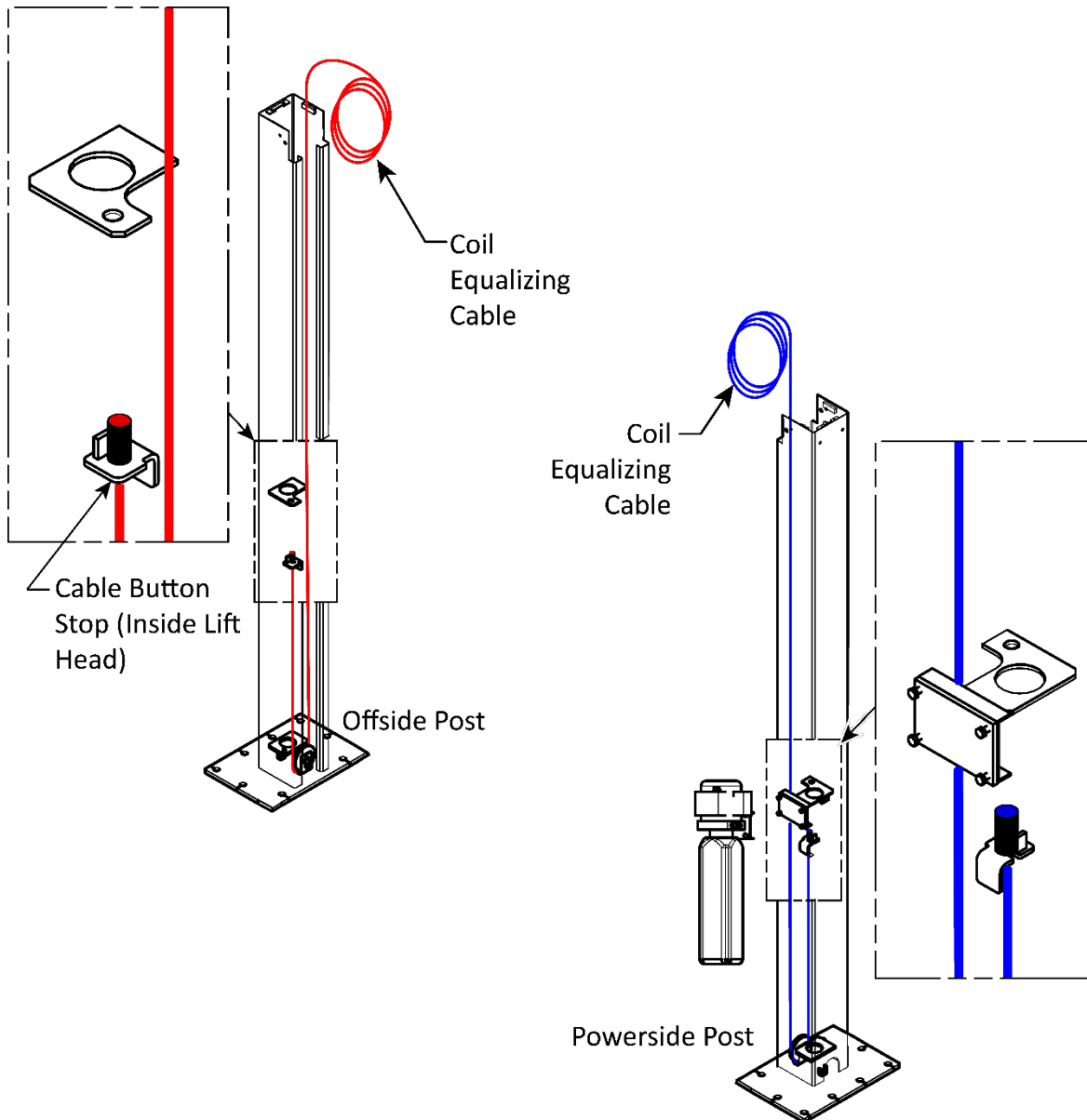

Not to scale, components removed for clarity.

To put the Equalizing Cables into position:

1. Put both Posts either flat on the ground or elevated on a sawhorse or similar. The **insides** of the Posts must be accessible, facing up.
2. Slide the Lift Heads away from the bottom of both Posts. Far enough to provide access to the bottom of the Lift Post and the Post Sheave.

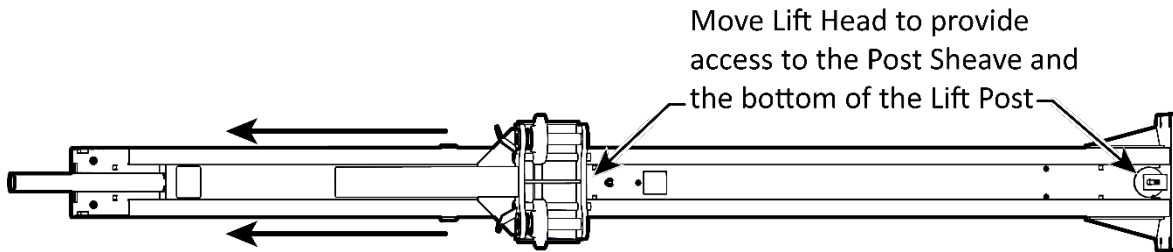

Reference only – do not scale.

3. Retrieve the two Equalizing Cables for your Lift. Each model has a specific Equalizing Cable length as noted in the table below.

Model	Part Number	Equalizing Cable Assembly Dia. and Length
12APX	5595758	Ø12 x 10,440 mm
12APX-192	5595760	Ø12 x 11,660 mm

4. Remove the Post Sheave from the bottom of both Posts.

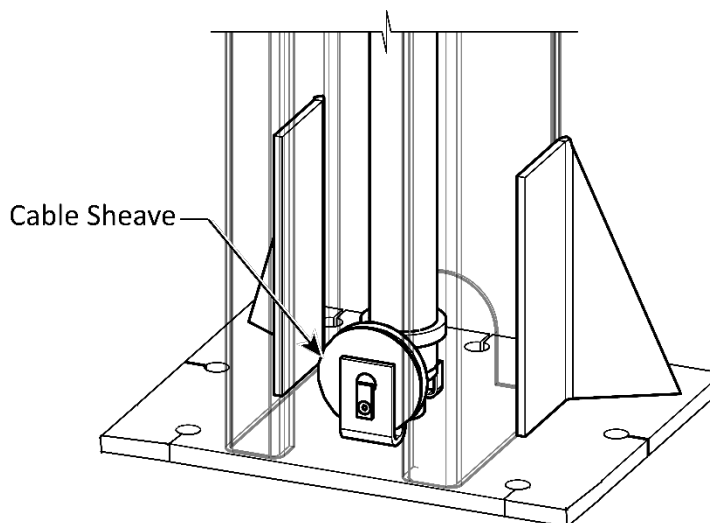

*Illustration shows the Cable Sheave near the bottom of the Post.
Reference only – do not scale.*

NOTICE Keep the Post Sheave, Sheave Pin, and Bolt nearby; you will be re-installing them soon.

5. Select an Equalizing Cable and locate the Button End you are going to use:
6. Push the Button end up through the bottom of the Lift Head up towards the Cable Button Stop, then push the Button end into the Slot in the Cable Button Stop.

Important

If you are having problems getting the Button end into the Slot, try pushing the Button end past the Button Stop and out the Hole at the Top of the Lift Plate; now, move the Equalizing Cable around to get the Cable into the Slot. Once the cable is in the Slot, pull back on the other end of the Cable to slide the Button end into the Slot. Try to keep the Cable taut until the Equalizing Cable is connected at the other end, done later in the installation. Note that it can be difficult to get the cable back into the Slot if it comes out.

7. Route the Equalizing Cable down to where the Post Sheave used to be and then up again towards the top of the Post.
8. Lubricate the Sheave Pin and Bearing with Red Lithium Grease, then replace the Post Sheave, making sure the Equalizing Cable is routed under it and in the Sheave.
9. Push the Threaded end of the Equalizing Cable through the Lift Head and out the Hole at the Top of the Lift Head.

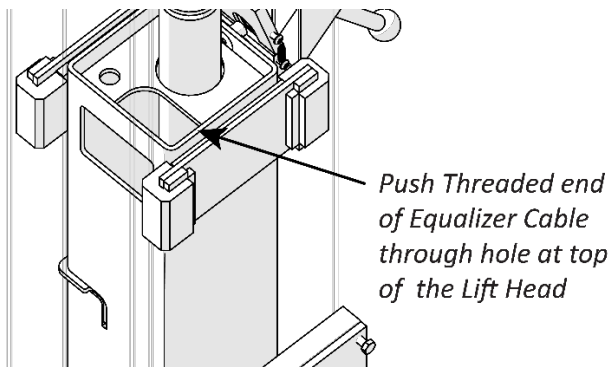
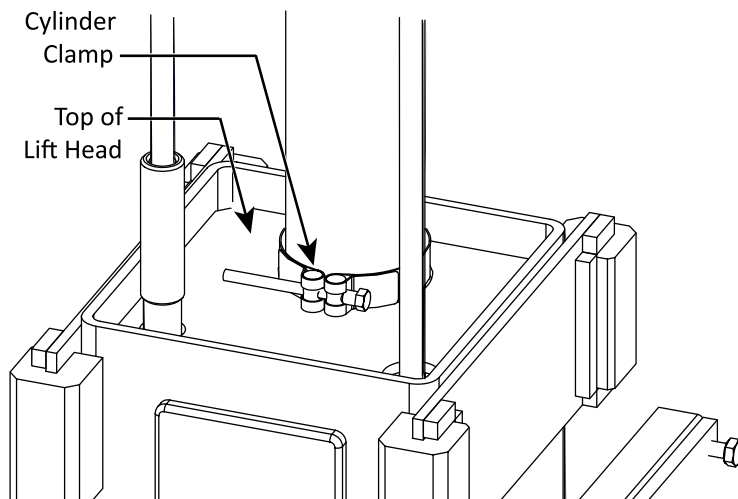

Illustration shows the opening in the Lift Head, which is where you route the Threaded end of the Equalizing Cable.

Not all components are shown. Reference only – do not scale.

10. Coil up and bind the remainder of the Cable (the portion above the Hole at the Top of the Lift Head), then leave it resting on top of the Post until later in the installation.
11. Move both Lift Heads back down to the bottom of each Post.
12. Verify the Cylinder Clamps are secured in place above the Hydraulic Cylinders.



Reference only – do not scale.

⚠ WARNING Verify the Cylinder Clamps are positioned at the top of the Lift Head and secured.
Do not operate the Lift if the Cylinder Clamps are not secured on the Hydraulic Cylinders.

Note: 12APX-192 Series models are supplied with **Post Extensions** that raise the height of the Posts to allow you to raise taller Vehicles.

The Post Extensions are slipped over the top of both Posts and then bolted into place.

Reference only – do not scale.

To install the Post Extensions:

1. Locate the two Post Extensions and the 4 Hex Head Bolts, 8 Flat Washers, 4 Split-Lock Washers, and 4 Nuts. Reference the illustration above for part numbers.
2. Slide one of the Post Extensions over the top of one of the Posts.
The opening in the Post Extension faces the inside of the Lift.
3. Secure the Post Extension to the Lift Post, using the hardware listed in the illustration above.
4. Install the remaining Post Extension on the remaining Lift Post and secure it the same manner.

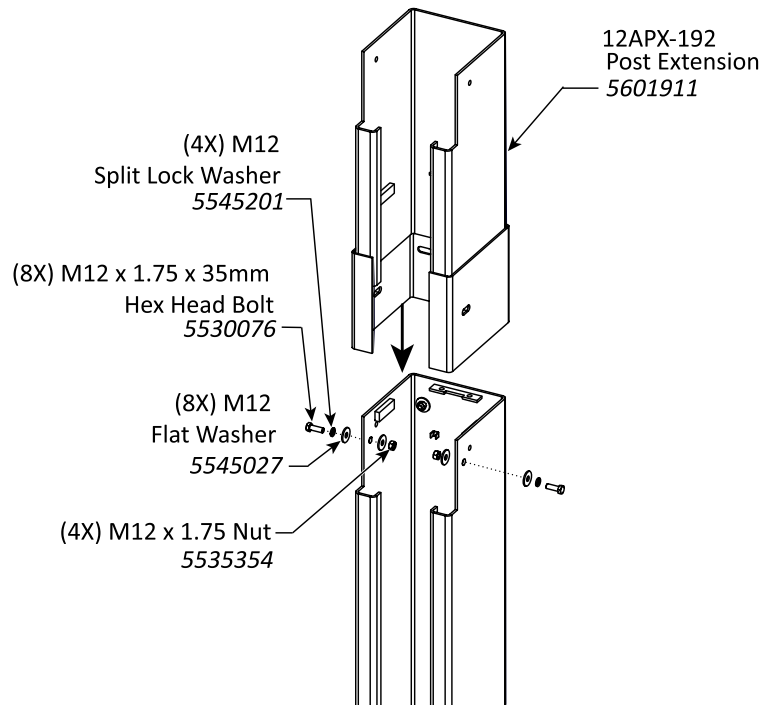



IMPORTANT! PLEASE READ NOW



Hydraulic Fluid Contamination poses a serious issue for your Lift; contaminants such as water, dirt, or other debris can get into the Hydraulic Hoses and Fittings on the Lift, making your new Lift inoperable and unusable.

Your Lift is shipped with clean components; however, BendPak strongly recommends that you take secondary precautions and clean all Hydraulic Hoses and Fittings prior to making connections. It is better and less costly to take these extra steps now so that you do not need to take your Lift out of service later to fix issues that could have been prevented at the time of installation.

There are several ways to clean Hydraulic Hoses and Fittings:

- **Compressed Air.** Use an air compressor to blow out contaminants from each Hydraulic Hose and Fitting prior to installation. Clean, dry air is preferred. Wear ANSI-approved eye protection (safety glasses, goggles, or face shield) when using compressed air for cleaning. Never point an air hose nozzle at any part of your body or any other person.
- **Fluid Flushing.** If the Hydraulic Fluid is clean and compatible with the system fluid, you can flush Hoses and Fittings to create turbulent flow and remove particulates. Always ensure that the fluid itself is contaminant-free.

Some additional steps that will help keep the Hydraulic Fluid clean:

- **Remove old thread seal tape.** Some ports on the Hydraulic Cylinders are shipped with temporary plugs secured with thread seal tape, so make sure to thoroughly remove any leftover thread seal tape that may inadvertently enter the Hydraulic System.
- **Use a liquid thread sealant only.** Liquid thread sealant (Loctite™ 5452 or similar) is recommended. Do not use thread seal tape on any fitting. Liquid thread sealant is recommended for NPT connections, fine for JIC connections, but *not* necessary for O-ring (ORB) connections.
- **Always use clean equipment.** If you use a dirty bucket or funnel to transfer the Hydraulic Fluid into the Hydraulic Fluid Reservoir, the contaminants will likely be introduced into the Fluid. When using cleaning rags, use a lint-free rag.
- **Proper storage.** Keep the Hydraulic Fluid sealed in its container until ready for use; store the Fluid in a clean, dry, and cool area.
- **Cover the Hoses and Fittings.** Before installation, do not leave the ends of the Fittings exposed; the same applies for the Hydraulic Hoses. As a general rule, keep the Hydraulic Hoses and Fittings capped and in a clean area until ready for use.
- **Filter the new Hydraulic Fluid.** Just because it is new does not necessarily mean it is *clean*. Use an offline filtration cart or kidney loop system to make sure the Hydraulic Fluid is clean before being transferred into the Hydraulic Fluid Reservoir (even using a heavy-duty nylon mesh screen is better than trusting what is left at the bottom of the barrel).
- **Avoid mixing different types of Hydraulic Fluid.** If Hydraulic Fluid needs to be replaced, make sure to flush the Hydraulic System of the old Hydraulic Fluid before you add the replacement Fluid; do not mix the two together.

About Thread Sealants

Liquid Thread Sealant lubricates and fills the gaps between the Fitting threads and leaves no residue that could contaminate the Hydraulic Fluid.

Other types of Thread Sealants (like Teflon Tape) can shred during installation or removal and eventually enter the Hydraulic System.

Thread Sealant can be used with most Hydraulic Fittings, although you probably only need to use with NPT connectors.

Apply the thread sealant when the ambient temperature is between +46.5°F to +70°F (+8°C to 21°C).

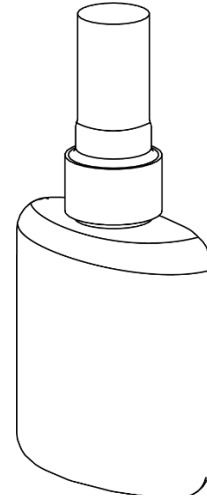

To apply Thread Sealant:

1. Make sure the Fittings and connectors you are going to use are clean and dry.

If you are adding Thread Sealant to a Fitting or connector that has already been used with a different sealant, use a wire brush to thoroughly remove the old sealant before adding more.

2. Skipping the first thread, apply a small amount of Thread Sealant to the next four threads of the Fitting.

⚠ WARNING Always wear the proper protective equipment when handling Thread Sealant.

You only need a small amount because the sealant spreads to the other threads as it is tightened into place.

If you put too much, the excess liquid will be pushed out when the Fitting is tightened; use a rag to wipe the excess.

3. Tighten the Fitting into the connector; do **not** over tighten the Fitting.
4. Allow the **24-hour** manufacturer-recommended curing time before pressurizing the system.

Identifying Hydraulic Fittings

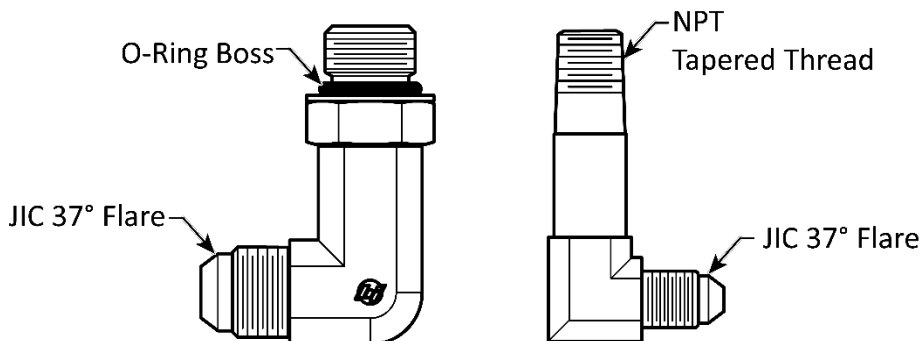











Joint Industry Council (JIC)

National Pipe Thread (NPT)

Hydraulic System Warnings

Before applying power to the Hydraulic System note the following Warnings:

-  **WARNING** Failure to observe these warnings can result in serious personal injury including, in rare cases, death.
-  **WARNING** The Hydraulic hoses and connections **must** be inspected before any attempt to raise a Vehicle is made.
-  **WARNING** Verify all Hydraulic Hose connections and fittings, including unused auxiliary port plugs on the Power Unit, the Flow Divider, the Cylinders and anywhere else in the Hydraulic System are tightened.
-  **WARNING** The Power Unit is a Hydraulic Pump capable of developing pressures in excess of 5,000 psi (345 BAR). A pressure relief valve is used to set the pressure at the desired level. Tampering with, adjusting, modifying, or removing the relief valve is extremely dangerous and is not permitted. Only trained Hydraulics technicians are permitted to adjust the relief valve, using calibrated hydraulic pressure gauges to ensure the proper pressure setting is achieved.
-  **WARNING** Changes to the output pressure may render the power unit incompatible with pressure limitations of other components in the hydraulic circuit. This may cause catastrophic failure of those components, and could result in property damage, serious personal injury, or death.
-  **WARNING** The Hydraulic System may contain high pressure which, if suddenly released, can cause severe injury, or death.
-  **WARNING** Do **not** attempt to connect or disconnect Hydraulic Hoses while the equipment is loaded or while a Vehicle is on the Lift, or the Hydraulic System is under pressure.
-  **WARNING** Keep bare hands away from Hydraulic Fluid; always wear gloves when handling Hydraulic Fluid, Cylinders or Hydraulic Hoses.
-  **WARNING** When handling Hydraulic Fluid, always observe the safety instructions from the manufacturer.
-  **WARNING** **Always** promptly clean any Hydraulic Fluid spills. If a leak is the source of the spill, lockout the Lift to prevent use until the Hydraulic System is repaired.

Route the Hydraulic Hoses

It is easier to put some hydraulic components into position **before** standing up the Posts.

All 12APX Series Lifts use three Hydraulic Hoses (Hose C longer on 12APX-192):

Lift Model	12APX Hose size	12APX Part No.	12APX-192 Hose Size	12APX-192 Part No.
Hose A	Ø10 x 2,790 mm	5570290	Ø10 x 2,790 mm	5570290
Hose B	Ø6.4 x 3,870 mm	5570238	Ø6.4 x 3,870 mm	5570238
Hose C	Ø6.35 x 7,950 mm	5570254	Ø6.35 x 9,168 mm	5570255

Hydraulic Hoses and Hydraulic Fitting locations are detailed in the drawing below.

Completed routing and locations shown for clarity.

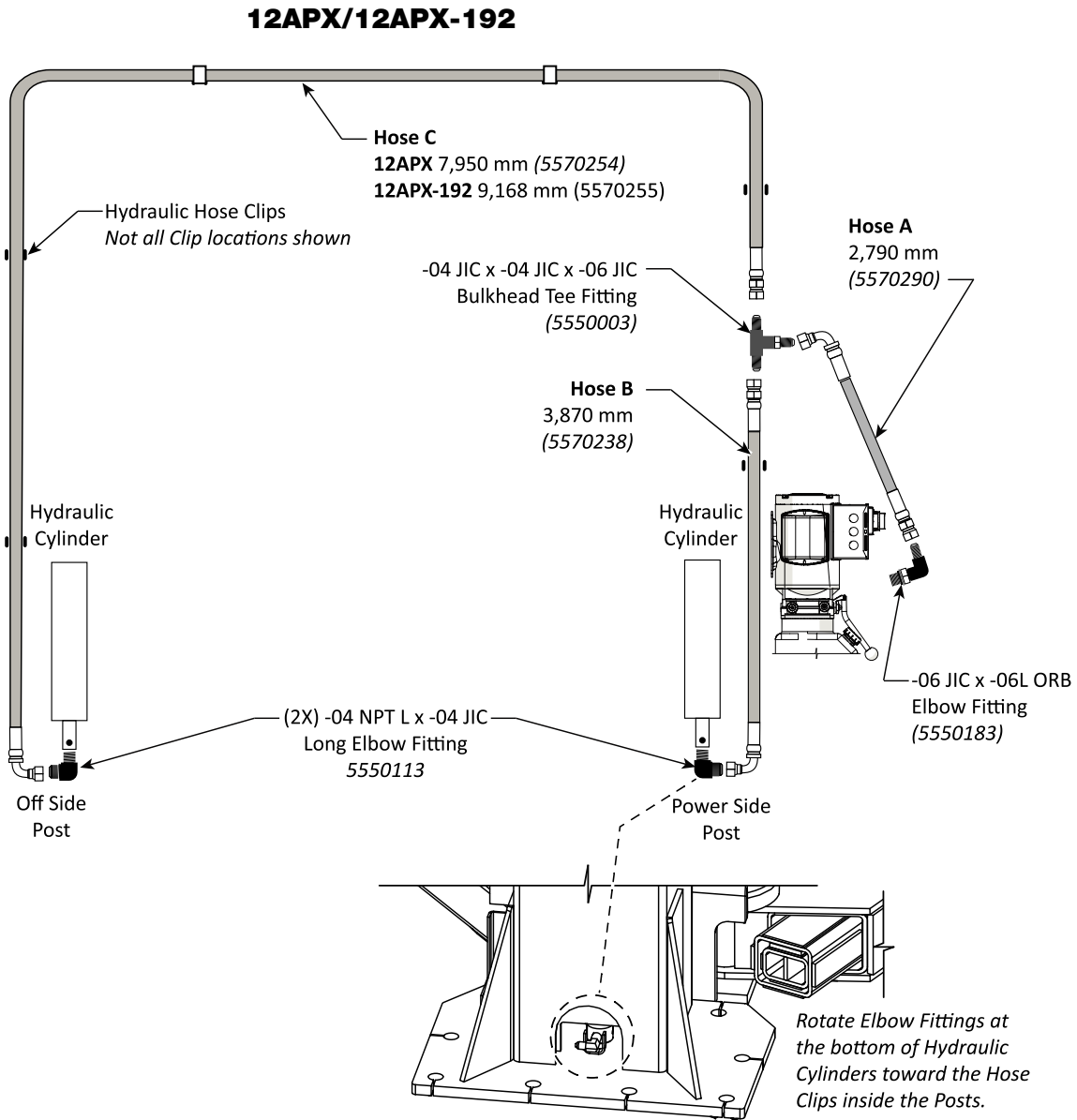

Figure for reference only – do not scale.

To put the Hydraulic Hoses into position:

Note: Use liquid thread sealant on the NPT male threads only. (See “About Thread Sealant”).

1. Locate the 3 Hydraulic Hoses and necessary Hydraulic Fittings: Two matching Long Elbow Fittings (5550113), one Bulkhead Tee Fitting (5550003), and one Elbow Fitting (5550183).

NOTICE The Power Unit Elbow Fitting (5550183) and the Short Hydraulic **Hose A** will not be installed until the Power Unit is installed.

2. **Starting most of the way up the Power Side Post**, install the (-06 JIC) Bulkhead Tee Hydraulic Fitting (5550003) in the Power Side Post through the hole above the Power Unit Mounting Bracket from inside the Power Side Post.
3. Secure the Tee with the Jam Nut on the **outside** of the Power Side Post to secure the Bulkhead Tee in place.
4. **Switching to the bottom of the Power Side Post**, remove the Shipping Plug from the Hydraulic Cylinder.

Important Keep a rag nearby in case fluid leaks out of the Cylinder when the Plug is removed.

5. Apply Thread Sealant to the NPT side of a Long Elbow Fitting (5550113) and thread the NPT side into the Hydraulic Cylinder and tighten appropriately. Point the JIC end of the Fitting toward the side of the Post with the Clips.
6. Turn the Hydraulic Cylinder so that the Long Elbow Hydraulic Fitting is accessible from the bottom back side of the Power Side Post.

NOTICE When routing Hydraulic Hoses, after they are positioned correctly, place them into the nearby Clips inside the Posts and lightly crimp the Clips together. When all Hydraulic Hoses have been installed, go back and fully crimp all the Clips. Making sure the hoses are flat against the inside of the post and will not interfere with any moving components.

7. Connect the Straight End of Hydraulic **Hose B** to the bottom of the Bulkhead Tee Fitting (5550003) and tighten securely.
8. Push the 90° End of the Medium Hydraulic Hose down to the bottom of the Power Side Post and connect it to the JIC end of the Long Elbow Hydraulic Fitting (5550113) and tighten securely.
9. **Switching to the Off Side Post**, remove the shipping plug from the Hydraulic Cylinder.
10. Apply Thread Sealant to the NPT side of the remaining Long Elbow Fitting (5550113). Thread this fitting into the Port at the bottom of the Hydraulic Cylinder. **Use liquid thread sealant on the NPT male threads only. (See “About Thread Sealant”).**
11. Tighten the Elbow Fitting securely. Make sure to leave the unconnected end of the fitting pointing towards the side of the post with the Clips.
12. Take the Long Hydraulic **Hose C**, push the 90° End down through the Post, then connect that End to the Elbow Fitting (5550113) just connected to the cylinder and tighten securely.
13. Clip the Long Hydraulic Hose into the Clips along the inside of the Post.
14. Carefully coil up and bind the rest of the Long Hydraulic **Hose C**, then leave it resting at the top of the Off Side Post until later in the installation.

Create Chalk Line Guides

Based on the Specifications for your Lift, create Chalk Line Guides on the ground for the two Posts prior to moving them into position.

Use the **Overall Width** value in **Specifications** for your Lift model to determine where to place the Chalk Line Guides. The Overall Width value is defined as the distance from the back of one base plate to the back of the other base plate.

The following illustration shows how to create Chalk Line Guides for a 12APX Series Lift.

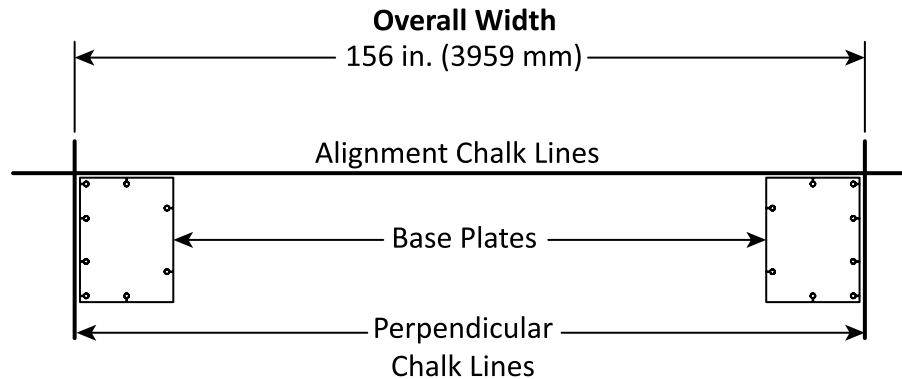

Top View of the Base Plates. Not all components are shown.

To add Chalk Line Guides:

1. Decide where the Lift will be located. Verify the clearances around the Lift area.
2. Create an Alignment Chalk Line at the Front of the Lift.

Make the Alignment Chalk Line longer than the **Overall Width** setting for your Lift model.

3. Create two Perpendicular Chalk Lines at 90° angles to the Alignment Chalk Lines at the **Overall Width** distance for the Lift model you are installing.

The two Perpendicular Chalk Lines must be a specified distance from each other, the **Overall Width setting 156 in. (3,959 mm)**.

4. When you move the Posts into position, put the Base Plates into the corners created by the Chalk Line Guides, as shown in the figure above.

Anchoring the Posts

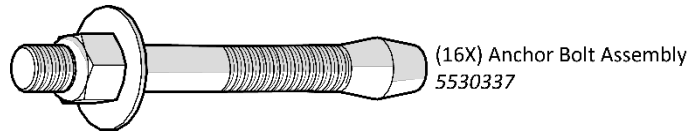

⚠ DANGER Pay special attention when installing the Posts. If done incorrectly, the Lift could fall over, potentially causing damage to the Vehicle, the Lift, and injuring bystanders. BendPak strongly recommends consulting a Concrete Specialist early in your planning process for Lift installations. A Concrete Specialist will make adjustments to account for national, state, and local building codes as well as local weather conditions, soil composition, base preparation, load bearing, seismic requirements and any other structural concerns that may arise.

Concrete specifications are:

- **Depth:** 6 in. (150 mm) thick, minimum, steel reinforced.
- **PSI:** 3,000 PSI, minimum
- **Cured:** 28 days, minimum

Anchor Bolt specifications are:

- **Length:** 6.3 in. (160 mm)
- **Diameter:** 0.75 in. (19 mm)
- **Anchor torque:** 85 – 95 pound feet
- **Effective embedment:** 3.25 in. (82.5 mm) or more

The Concrete floor where the Lift will be installed must meet the following requirements:

- The floor must be a flat, level concrete floor. **Do not install the Lift on a surface with more than three degrees of slope.**
- Do not install the Lift on cracked or defective Concrete.
- Check the floor for the possibility of it being a post-tension slab. In this case, contact the building architect before drilling. Contact a qualified professional to locate the tensioned cables before drilling.

⚠ WARNING Cutting through a tensioned cable can result in injury or death. Do not drill into a post-tension slab unless the building architect confirms you are **not** going to hit a tensioned cable, or you have located it using ground penetrating radar. **If colored sheath comes up during drilling, stop drilling immediately.**

⚠ WARNING The concrete and Anchor Bolts **must** meet these specifications. Only install your Lift on a Concrete surface. If you install a Lift on asphalt or any other surface, or your Concrete or Anchor Bolts do not meet these specifications, it could lead to product damage, Vehicle damage, personal injury, or even loss of life.

BendPak Lifts are supplied with installation instructions and concrete fasteners meeting the criteria as prescribed by the latest version of the American National Standard “Automotive Lifts – Safety Requirements for Construction, Testing, and Validation.”

⚠ WARNING Use **only** the ALI-certified Anchor Bolts that came with your 12APX Series Two-Post Lift. If you use components from a different source, you void your warranty and compromise the safety of everyone who installs or uses the Lift.

Lift buyers are responsible for conforming to all regional, structural, and seismic anchoring requirements specified by any other agencies and/or codes, such as the Uniform Building Code and/or International Building Code.

NOTICE Consider *not* torquing the Anchor Bolts into position yet. Installing the Overhead Assembly and doing final leveling may be easier if there is some play in the Posts. Torque to specification after final leveling.

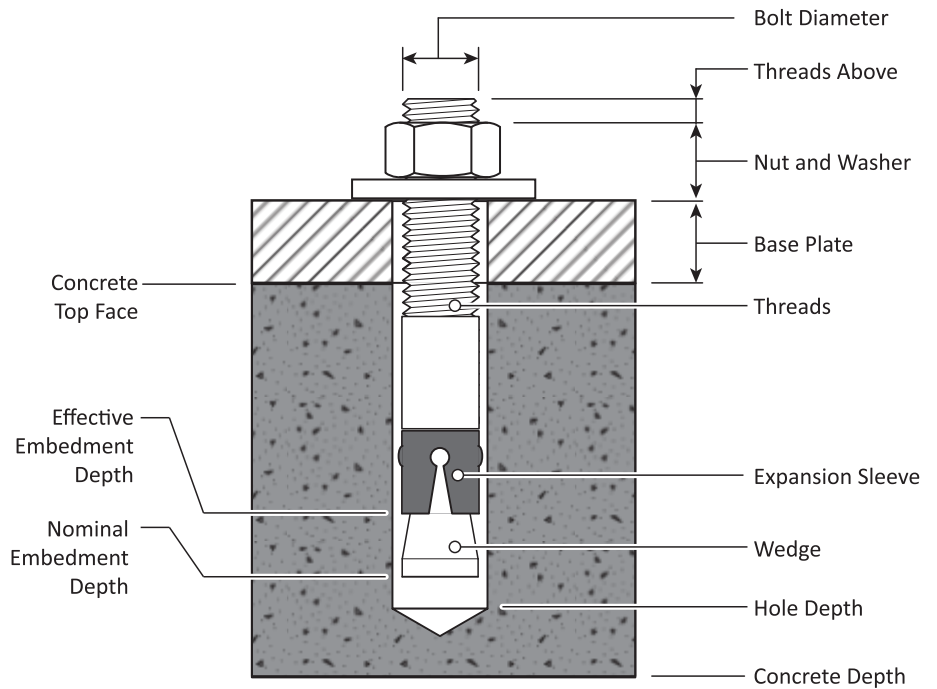

Effective Embedment is the location in the Hole where the Expansion Sleeve presses into the Concrete. This is where the Anchor Bolts get their holding strength, the farther down into the Hole, the greater the holding strength.

Nominal Embedment is how far down into the Hole the bottom of the Anchor Bolt is, which does not tell you anything about the holding strength.

To Raise and Anchor the Posts:

WARNING Verify the Cylinder Clamp is in place above the lift head **prior** to raising the Lift Posts.

WARNING **Pinch and crush hazards! Keep hands and feet clear of the Lift Head and Lift Post as it is raised.** You **must** use the appropriate safety gear including safety glasses, dust masks, gloves, steel-toed work boots and heavy work clothes when anchoring the Posts.

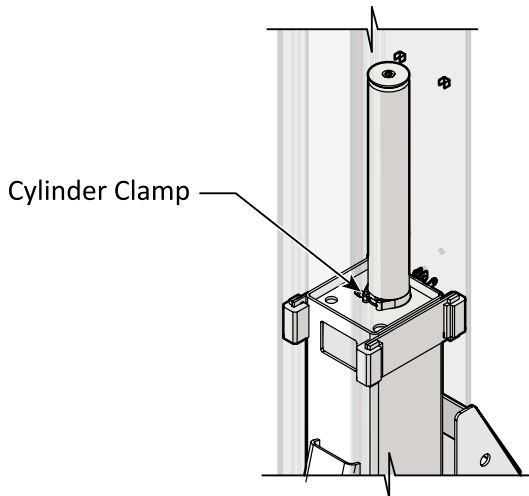

1. Using a Forklift or Shop Crane, move the Posts to the Chalk Line Guides you created earlier. Carefully stand up each Post, *one at a time*, and move them to the appropriate location.

⚠ WARNING Many of the Lift components are heavy and awkward to work with. Installation should be accomplished by competent personnel ensuring all heavy components are properly rigged and balanced for lifting. Installation personnel should have knowledge, training, and experience in lifting, rigging, and securing heavy objects.

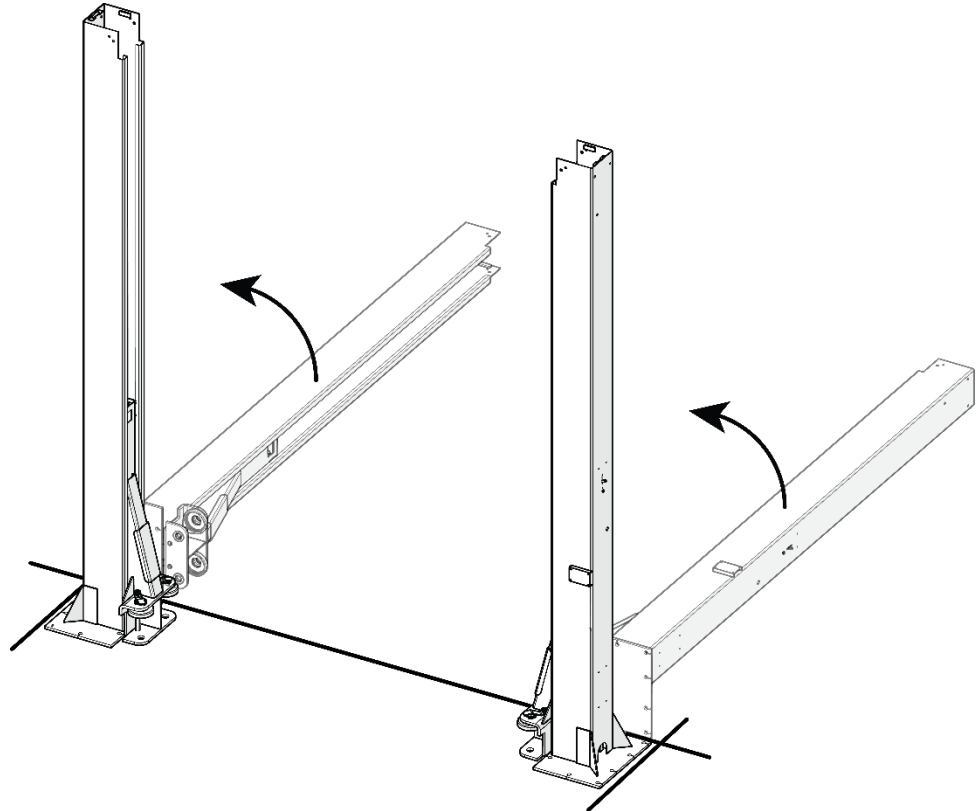

2. Double check your chalk Line measurements against the **Specifications** for your Lift model.

⚠ WARNING You **must** use the appropriate safety gear including safety glasses, dust masks, gloves, steel-toed work boots and heavy work clothes when anchoring the Posts.

3. Using the Base Plates as guides, drill each hole to a depth of **5 inches min.** using a masonry drill bit. Drill into the concrete straight; do not let the drill wobble.

The diameter of the drill bit must be the same as the diameter of the anchor bolt. Ensure the drill flutes are at least as long as the depth of the hole to effectively remove material as you drill.

Drill a pilot hole! Pilot holes allow straighter, cleaner drilling by removing the material directly from the center of the final drill. This reduces the amount of force required to keep the final drill straight and perpendicular to the floor.

If the drill hits rebar embedded in the concrete and the hole is not ruined, by making it too big or out of round, switch to a rebar cutting drill bit. Slow the drill speed to avoid overheating the drill bit. Continue drilling until you are past the rebar.

Do not rush. Pull the drill out of the hole frequently to remove debris and clear the opening.

Do not drill all the way through the Concrete; if you punch completely through the slab, you could compromise the holding strength of the Anchor Bolts.

4. Vacuum each hole clean. BendPak recommends using a vacuum to get the hole very clean.

A wire brush, hand pump, or compressed air may also be used. **Make sure to thoroughly clean each hole.**

Do **not** ream the hole. Do **not** make the hole any wider than the drill bit made it.

⚠ WARNING You **must** use the appropriate safety gear including safety glasses, dust masks, gloves, steel-toed work boots and heavy work clothes when anchoring the Posts.

NOTICE The holding strength of an Anchor Bolt is partially based on the how cleanly the Expansion Sleeve presses against the Concrete. If the hole is dirty or too wide, there is less holding strength.

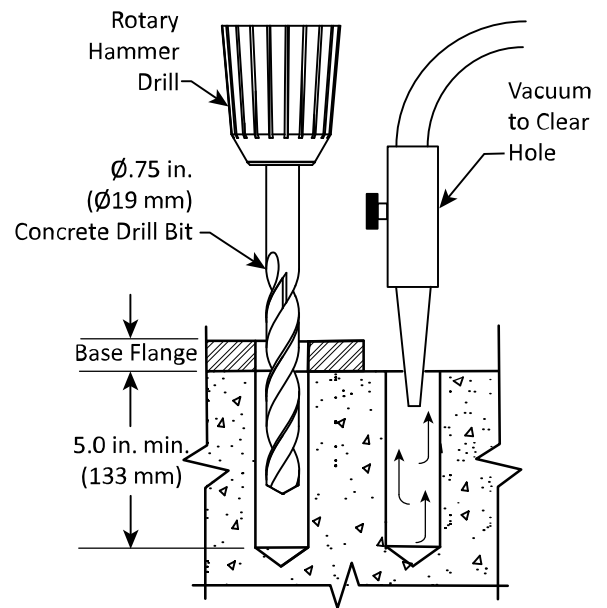

5. Make sure the Washer and Nut are in place, then insert the Anchor Bolt into the hole.

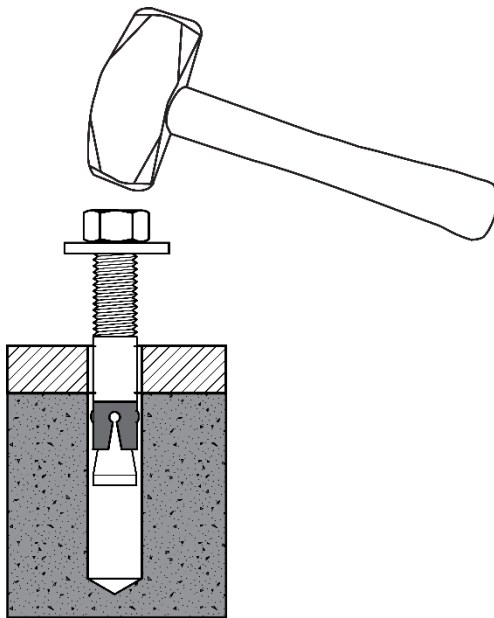

The expansion sleeve of the Anchor Bolt may prevent the Anchor Bolt from passing through the hole in the Base Plate; this is normal. Use a hammer or mallet to get the Expansion Sleeve through the Base Plate and into the hole.

Even using a hammer or mallet, the Anchor Bolt should only go into the hole part of the way; this is normal. If the Anchor Bolt drops in with little or no resistance, the hole is too large.

Once past the hole in the Base Plate, the Anchor Bolt eventually stops going down into the hole as the Expansion Sleeve contacts the sides of the hole; this is normal.

6. Hammer or mallet the Anchor Bolt the rest of the way down into the hole, and then stop when the Washer is snug against the Base Plate.
7. Verify each Post is plumb. Install Shims as required. See **Troubleshooting Lift Arm Lock Disengagement** if you are required to shim $\geq .5$ in. (13 mm).
8. Install the optional Adapter Trays which provide storage for Auxiliary Adapters — also called Extenders — conveniently near the Lift Arms.

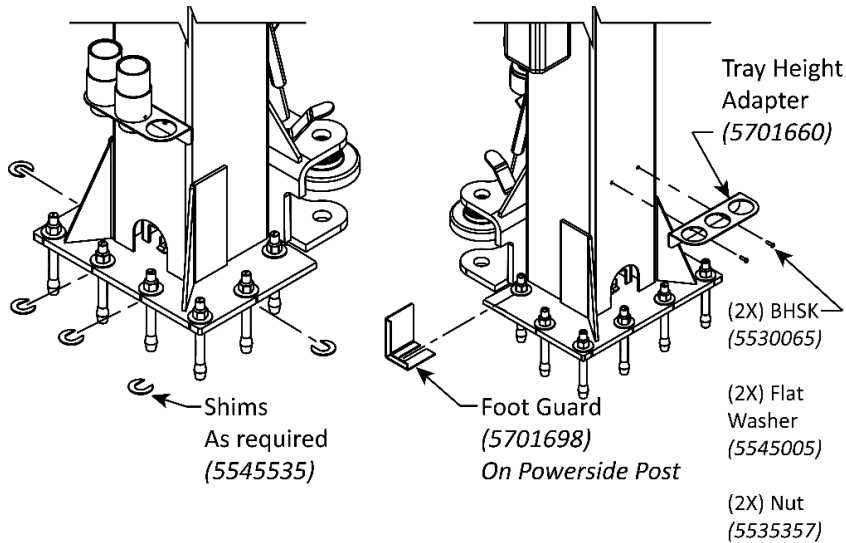

Tip

If planning to torque the Anchor Bolts later, so that installing the Overhead Assembly and final leveling is a little easier, skip the next step. Make sure the Anchor Bolts are securely in position. This will ensure that the Posts will not move too much during the rest of the installation.

9. Tighten each Nut **clockwise** to the recommended installation torque, 85 – 95 pound feet, using a Torque Wrench.



CAUTION

Do **not** use an impact wrench to torque the Anchor Bolts.

10. Install the Foot Guard on the Power Side Post as shown above.

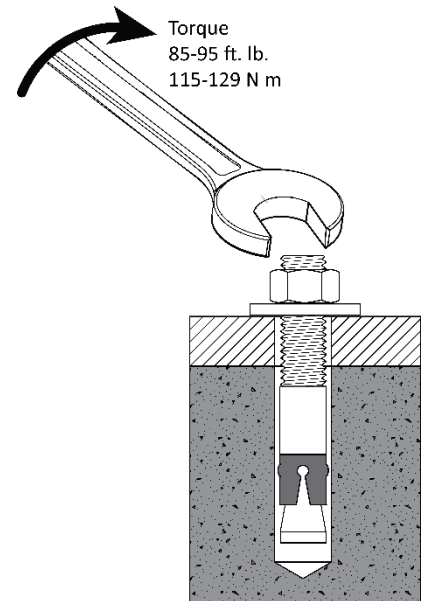

Install the Overhead Assembly and Limit Switch

The Overhead Assembly is installed above and between the Power Side and Off Side Posts. It supports the Equalizing Cables, the Hydraulic Hoses, the Limit Switch wiring, and the Safety Lock Cable.

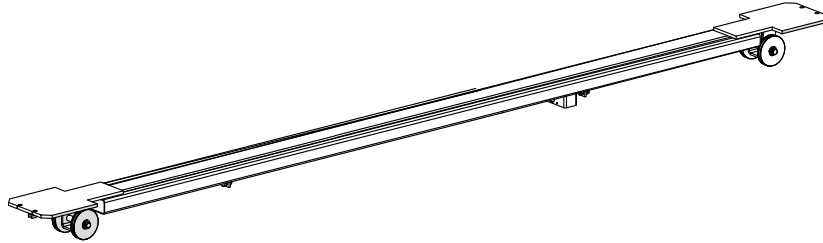

The Overhead Assembly and the Safety Shutoff Bar are assembled at the factory.

To prepare and install the Overhead Assembly:

1. Remove all four Overhead Assembly Sheaves, and their Pins from the ends of the Overhead Assembly pieces. Keep the Sheave components nearby, you will be reinstalling them in the same order in the next section.
2. Attach one end of the Stop Bar to the Overhead Assembly, as shown below; use the same type of M12 hardware to secure the other end of the Stop Bar.
3. The Overhead Assembly must be installed to place the Limit Switch closest to the Power Side Post.

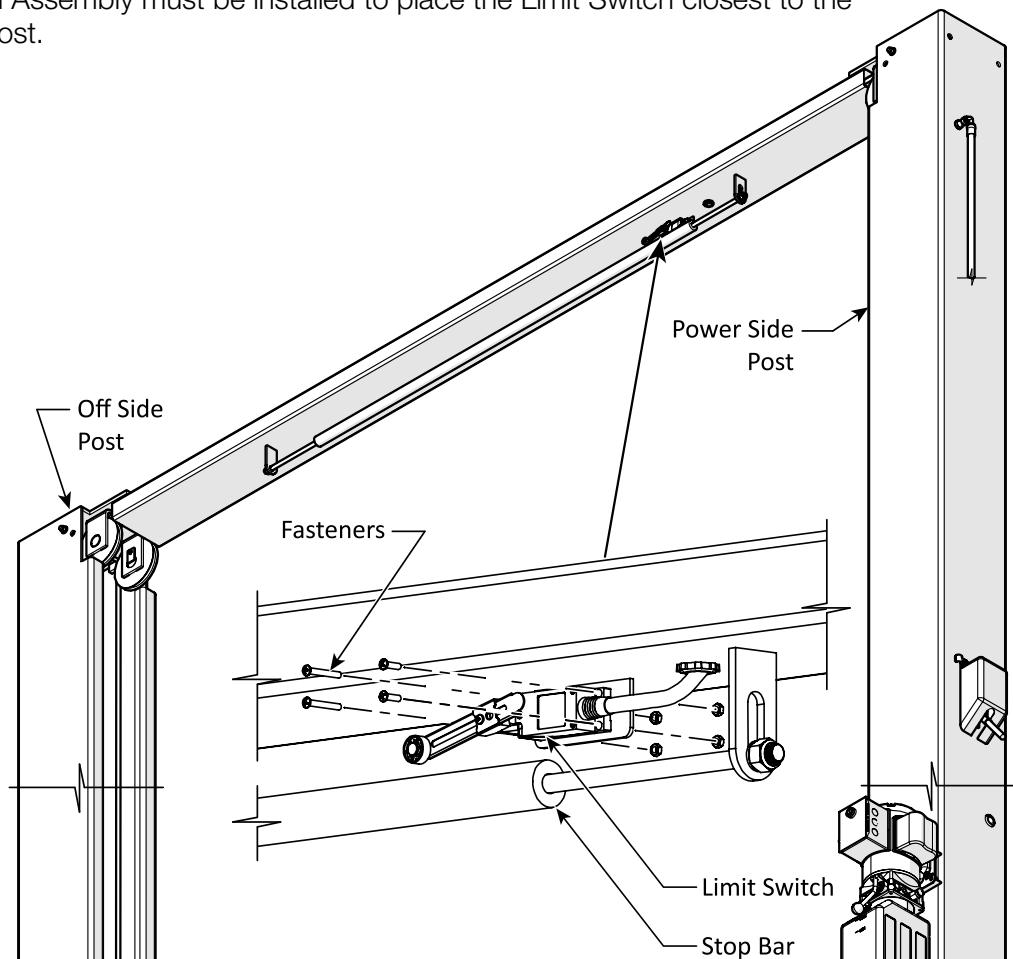

To install the Limit Switch:

1. Locate the Limit Switch and hardware required to install the Limit Switch.
2. Install the Limit Switch on the Limit Switch Bracket positioned so that the Safety Shutoff Bar, when moved upwards, will contact the Limit Switch Actuator Arm.

For Three-Phase Installations see [Three-Phase Limit Switches Installation](#).

3. Loosen the Arm Rotation Set Screw and rotate the Arm downwards until it contacts the Safety Shutoff Bar in its rest position. If necessary, adjust the arm length by loosening the Arm Length Set Screw. The Limit Switch should be free to travel and follow the Safety Shutoff Bar as it moves up and down. Refer to the figures below.

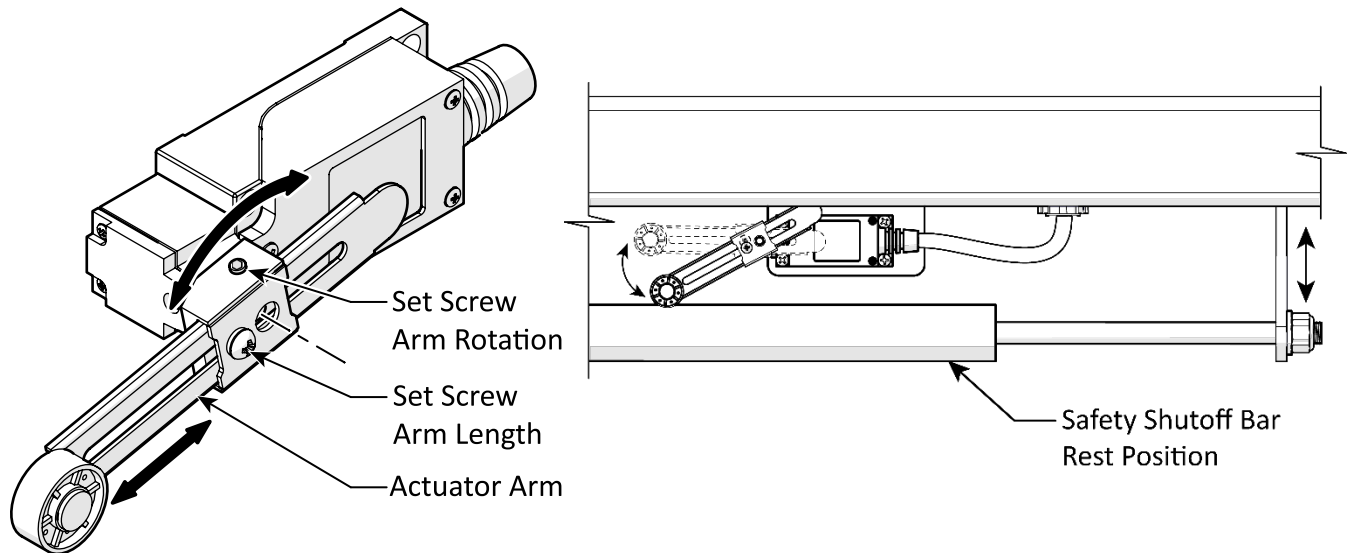

4. Use the supplied hardware to secure the Limit Switch and Limit Switch Cover in place.
5. Use an appropriate lifting device to put the Overhead Assembly into position, **making sure to position the Limit Switch Bracket on the same side as the Power Side Post.**
6. Bolt the Overhead Assembly to the top of the Posts using two Bolts, Lock Washers and M10 Nuts on each end.

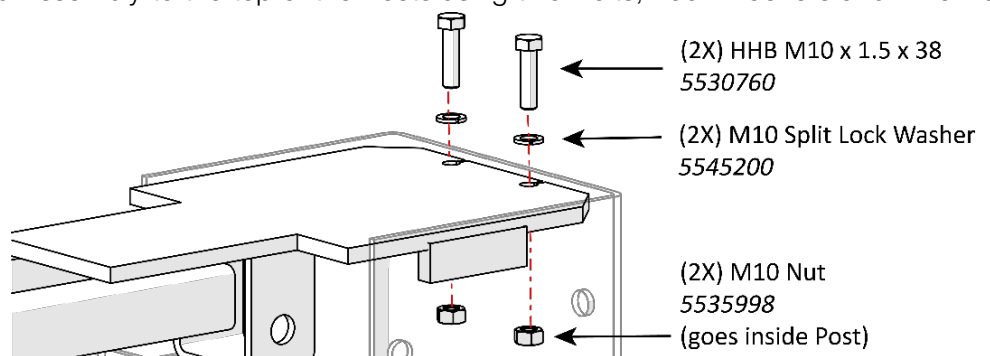

7. Route the Limit Switch wiring as shown on the next page and secure the Cable with the clips on the Overhead and inside the Power Side Post. Do not connect the cable to the Limit Switch. This task will be accomplished by the Electrician.

Leave enough of the 14-2 Cable near the switch and near the Power Unit for the electrician to make the connections.

The Limit Switch Cable exits the Power Side Lift Post below the Safety Release through a cable grommet and is routed to the Power Unit.

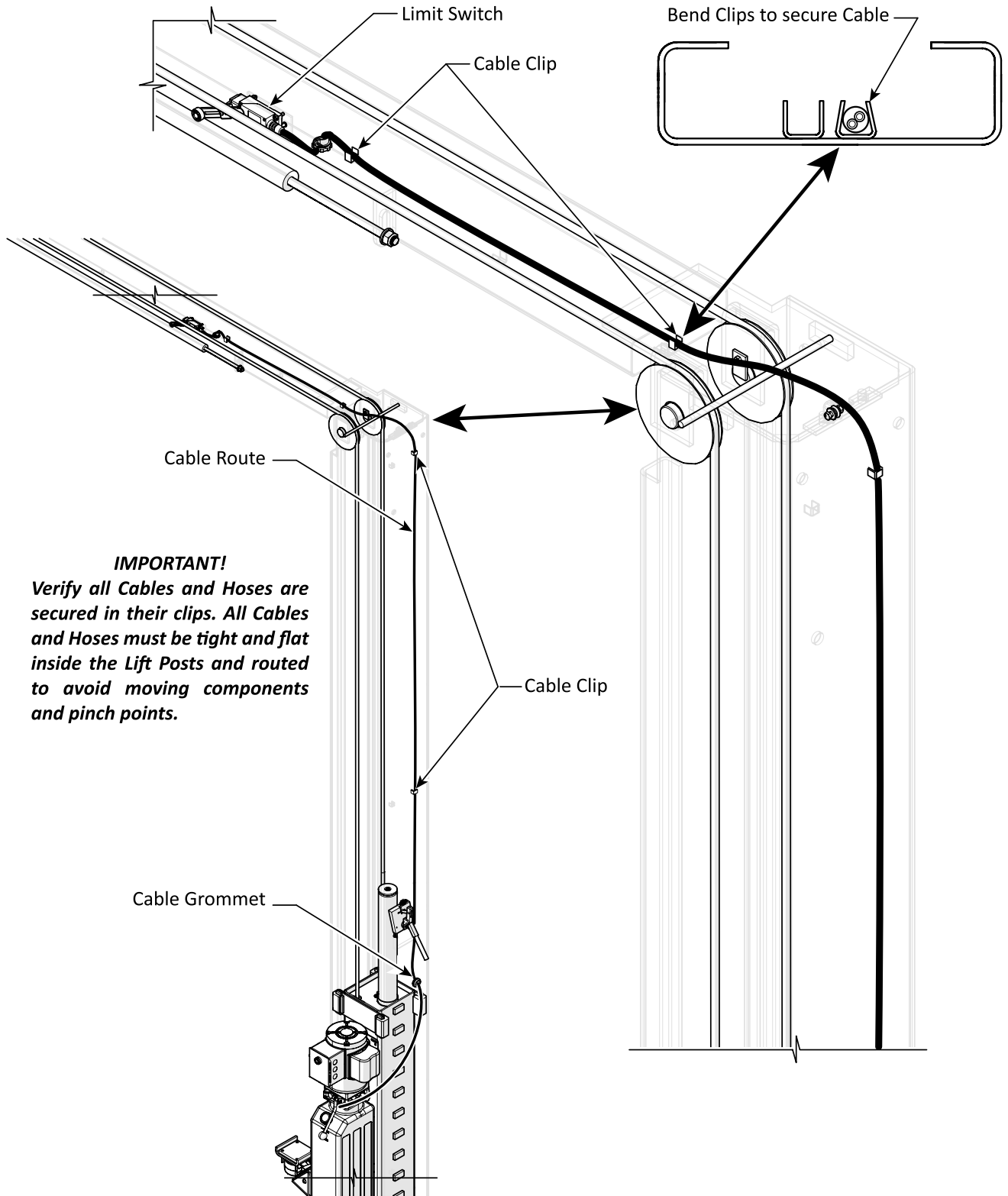

Complete the Equalizing Cables Installation

Both Equalizing Cables should have been put into position coiled at the top of the Lift Posts before the Posts were raised, which is covered in [Putting the Equalizing Cables into Position](#).

This section picks up where that section left off: the Button Ends of the Equalizing Cables (on both Posts) have been installed, routed around the Post Sheaves, and then pushed up above the Lift Head. They now need to be routed over the Overhead Assembly and then down to the top of the Lift Head.

NOTICE If your Equalizing Cables are not yet in position, you must go back and put them into position before performing the following procedure.

When Equalizing Cables are fully routed, they are mirror images of each other. Refer to the following figure for both 12APX and 12APX-192.

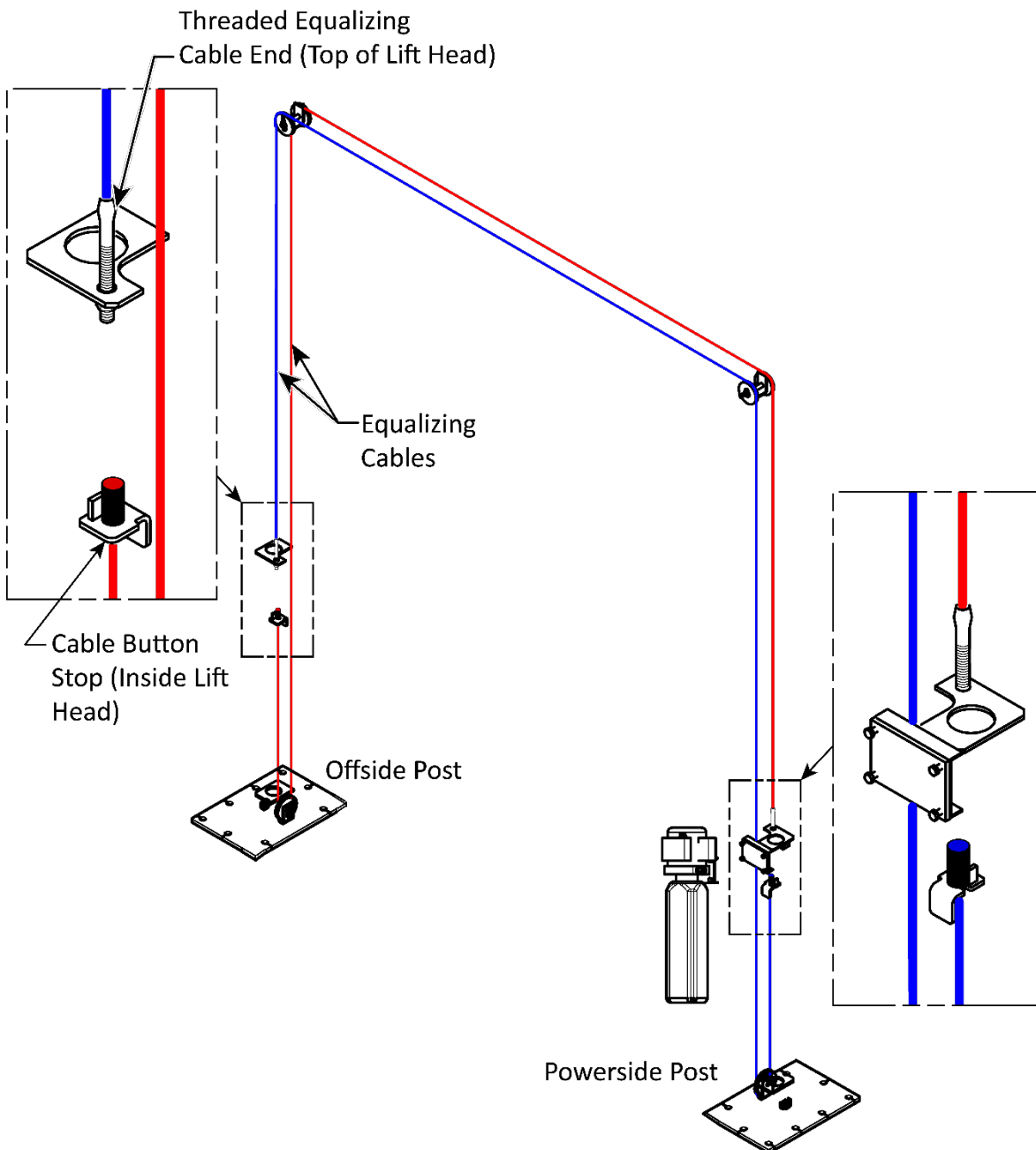

Components removed for clarity.

To Complete the Equalizing Cable installation:

1. Using a Forklift or Shop Crane, manually raise both Lift Heads about 28 in. (711 mm) off the ground and **engage them on the closest Safety Lock**.

Measure to verify both Lift Heads are the same distance off the ground.

⚠ WARNING You must use a 4 x 4 or jack stands to block and prevent the Lift Head downward movement while working under it.

⚠ WARNING You must use a proper lifting device such as a Forklift or Shop Crane to raise and position the Lift components. Make sure the Button Ends of both Equalizing Cables are still in the Slots in their Cable Button Stops, that both Equalizing Cables go under the Post Sheave in their Posts.

2. If either cable is not correct, correct it at this point; you cannot continue until the Equalizing Cables are in their correct starting positions.

Choose which one of the two Equalizing Cables you are going to put into position first, then remove the Nut from the Threaded End of that Cable.

NOTICE The Overhead Assembly Sheave, Sheave Pin, and Hair Pin were previously removed. If they were mistakenly re-installed, you need to remove them again.

3. Route the Threaded End of the Equalizing Cable up on the inside of the Post, over the Overhead Sheave Assembly, and then out over the top of the Overhead Assembly.

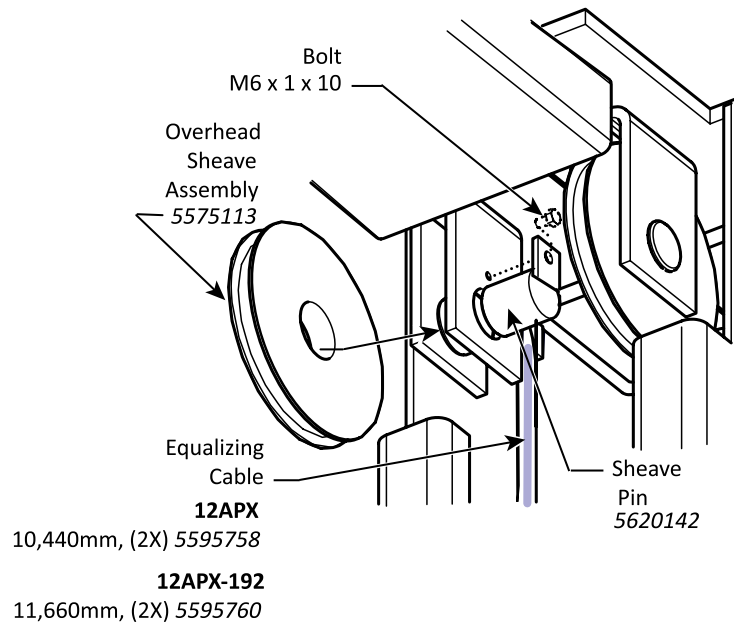

4. Lubricate the Sheave Pin and Bearing with Red Lithium Grease, then re-install the Overhead Assembly Sheave, Sheave Pin, and Hair Pin.
5. At the other Post, remove the Nut from the Threaded End of the other Equalizing Cable.
6. Route the Threaded End over the top of the Overhead Assembly Sheave, and then down the Post towards the Lift Head.

7. Lubricate the Sheave Pin and Bearing with Red Lithium Grease, then re-install the Overhead Assembly Sheave, Sheave Pin, and Hair Pin.
8. Place the Threaded End of the Equalizing Cable through the hole at the top of the Lift Head, then install the Nut and securely tighten.

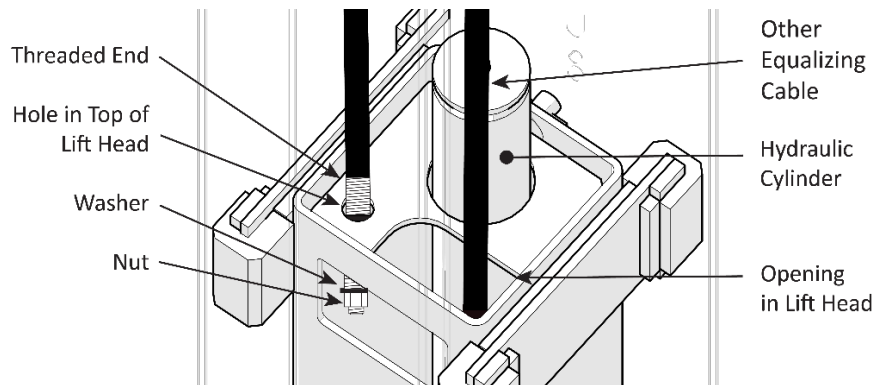

Reference only – do not scale.

9. Perform Steps 3 through 9 for the other Equalizing Cable.

Mount the Power Unit

This section describes mounting the Power Unit to the power side post. You do **not** need an Electrician to **mount** the Power Unit, but you do need an Electrician to **connect** the Power Unit to the facilities electrical system. Refer to **Connecting the Power Unit** for installation information for your Electrician and specific information about the Power Unit that came with your Lift.

NOTICE Do not connect the Power Unit to the Hydraulic System or to the power source at this point in the installation; those connections will be made later.

CAUTION The Power Unit is heavy. BendPak recommends having one person hold the Power Unit while a second person bolts it into place.

To mount the Power Unit:

1. Retrieve the supplied four M8 Hex Head Bolts, M8 Lock Washers, and one Vibration Dampener.
2. Remove the Power Unit from the packaging material.

Important The Power Unit is heavy. BendPak recommends having one person hold the Power Unit while a second person bolts it into place.

3. Move the Vibration Dampener into place next to the Mounting Bracket on the power side Post.
4. Move the Power Unit Mount Plate next to the Vibration Dampener.
5. Secure the Power Unit and Vibration Dampener using the fasteners listed in step 1, using all four openings to secure the Power Unit. Refer to the figure below.

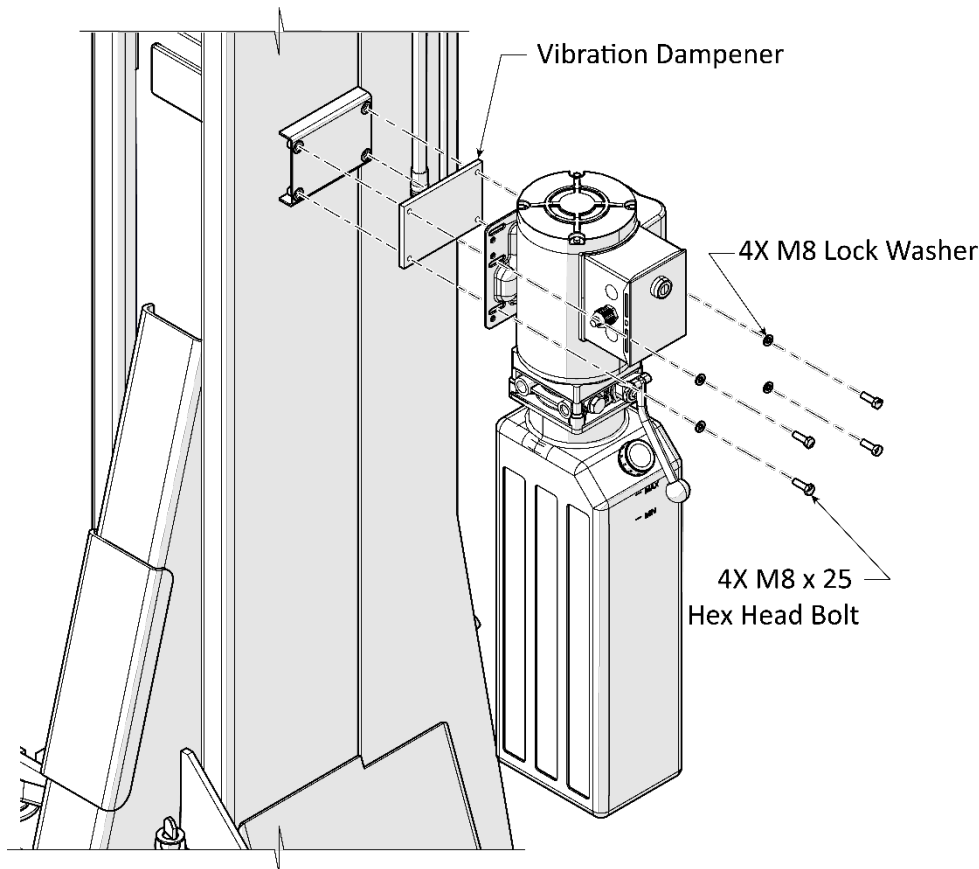

Install the Safety Lock Cable

The Safety Lock Cable and the Safety Lock Release Handle are used to release the Safety Locks, allowing the Lift to be lowered.

The Safety Lock Cable should have been installed and left in place in the [Installing the Safety Assemblies](#) section,

The following drawing shows the path the Safety Lock Cable travels from Safety Assembly on the Off Side Post to the Safety Assembly on the Power Side Post.

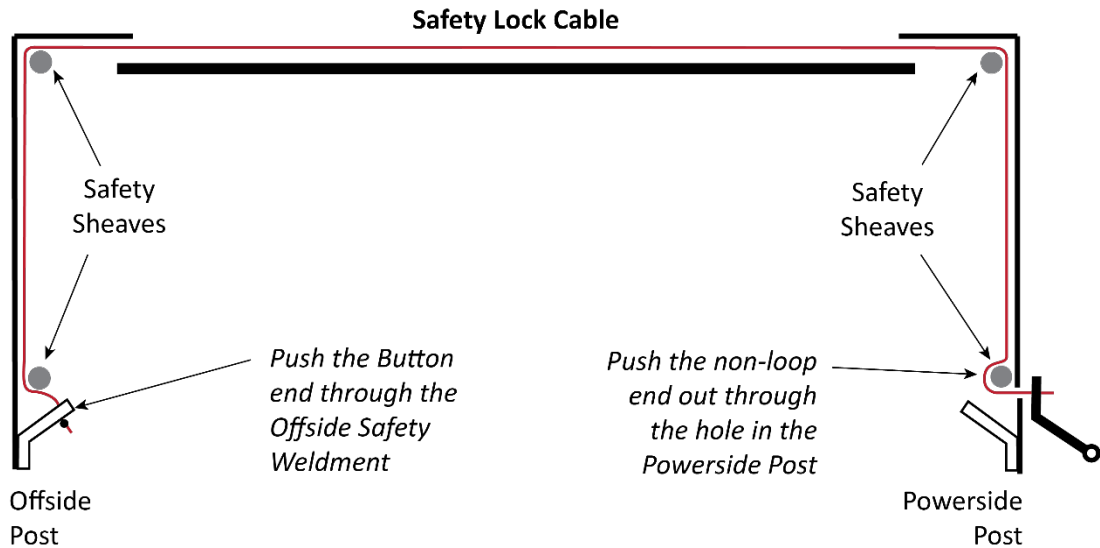

Not drawn to scale. Some components exaggerated or not shown for clarity.

The following illustration shows the Safety Lock Cable connections to the Safety Assemblies.

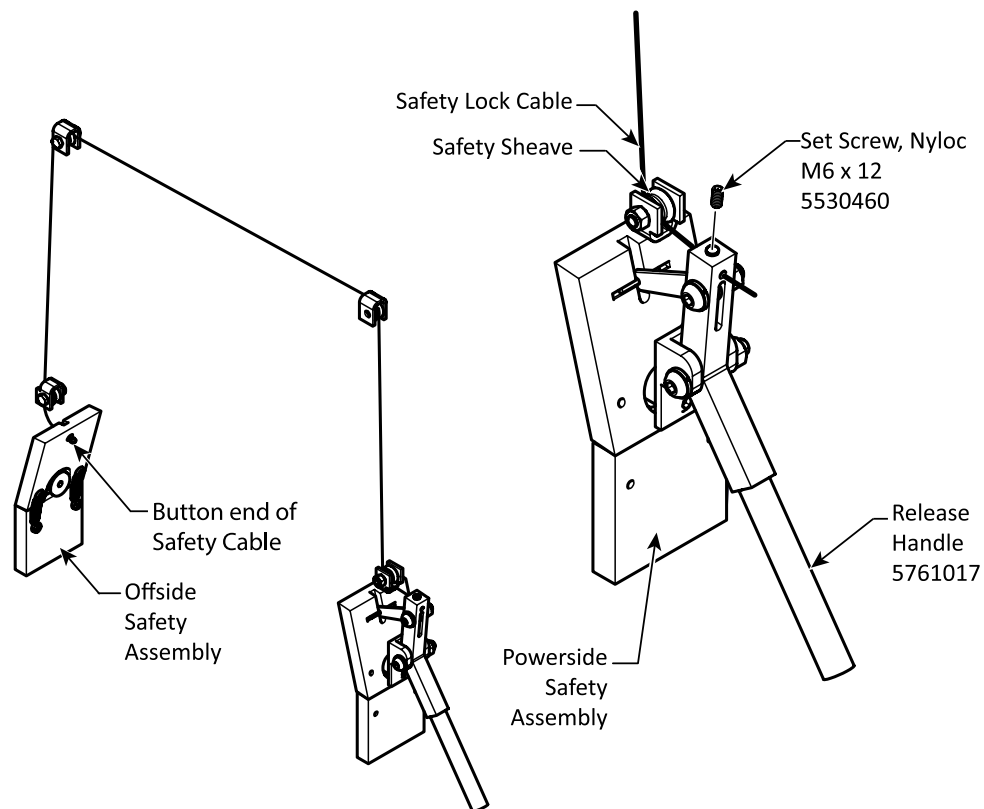

Reference only – do not scale.

⚠ WARNING You will need to access the Overhead Assembly to route the Safety Lock Cable. Use care to avoid falling when working on a ladder or other lifting device.

To route and connect the Safety Lock Cable:

1. Locate the Safety Lock Cable. This should be coiled at the top of the Off Side Post.
2. Route the non-button end under the Safety Sheave, upwards on the inside of the Off Side Post, up and over the Safety Sheave at the top of the Off Side Post, across the Overhead Assembly, over the Safety Sheave at the top of the Power Side Post, and then downwards, on the inside of the Power Side Post, towards the Power Side Safety Assembly.
3. **Switching to the Power Side Post**, route the non-button end of the Safety Lock Cable through the Safety Sheave.
4. Temporarily remove the M6 Set Screw (5530460) that is loosely secured in the Safety Lock Release Handle.
5. Route the Safety Lock Cable through the hole in the Safety Release Handle and apply tension, then replace the Set Screw. Tightly secure the connection.
6. Install the Safety Cover (5716072) to the Power Side Post; there is no Safety Cover for the Off Side Post. Make sure the Safety Lock Release is usable through the slot on the front.

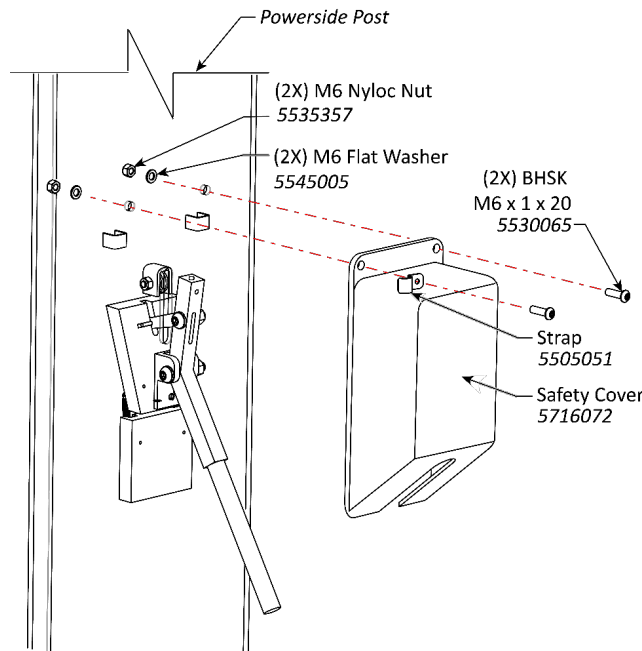

Figure not to scale. Components removed for clarity.

⚠ CAUTION Verify the Safety Lock Cable stays on its Safety Sheaves; this keeps it out of the way of the Equalizing Cables and the Hydraulic Hoses.

⚠ DANGER Verify both the Power Side and the Off Side Safety Assemblies engage properly **before** operating the Lift.

Finish Connecting the Hydraulic Hoses and Fittings

Some of the Hydraulic Hoses were put into place much earlier in the installation. If they were **not** put into position earlier, you must do so now, **before** beginning the following procedure. Refer to [Routing the Hydraulic Hoses](#) for full instructions.

To finish connecting the Hydraulic Hoses:

1. Locate the Ø10mm Short Hydraulic **Hose A** and the remaining Elbow ORB Hydraulic Fitting (5550183).
2. **On the Power Unit**, ensure that the Hydraulic Pressure Port on the Power Unit has the shipping plug removed and install the Elbow Hydraulic Fitting (5550183). Pressure ports are usually labelled P, P1 or P2.

IMPORTANT! Place a few drops of hydraulic fluid on the Elbow's O-ring before installing on the Power Unit.

Note: There are multiple Ports on the Power Units that are used with 12APX Series Lifts. However, each 12APX Series Lift *uses only one* Hydraulic Pressure Port (labeled **P1** in the drawing below). Do **not** connect to any of the other Ports and do **not** connect to more than one Hydraulic Pressure Port. All other Active Ports should remain plugged. Verify these plugs are tight.

3. Tighten the Elbow Fitting appropriately; make sure to leave the -06 JIC connector facing up, towards the Tee Fitting.
4. Connect the Curved End of the Short Hydraulic **Hose A** to the Tee Fitting; finger tighten the connection.

This connection is made on the outside of the Power Side Post. If the -06 JIC connector of the Tee Fitting is **not** on the outside of the Power Side Post, this means the Tee Fitting was not installed correctly. Return to **Routing the Hydraulic Hoses** for more information.

⚠ CAUTION Do not overtighten JIC fittings! Damage to the hose or fitting is likely.

5. Connect the Straight End of the Short Hydraulic Hose on the Elbow Fitting; finger tighten the connection.
6. **Switching to the Off Side Post**, take the Long Hydraulic Hose and route it over the Overhead Assembly towards the Power Side Post, making sure to put the hose through the Clips in the Post.
7. Connect the Straight End of the Long Hydraulic Hose to the -04 JIC connector facing up on the Tee Hydraulic Fitting; finger tighten the connection.
8. Using appropriate tools, go back and securely tighten all finger-tightened connections.

Power Ports Location

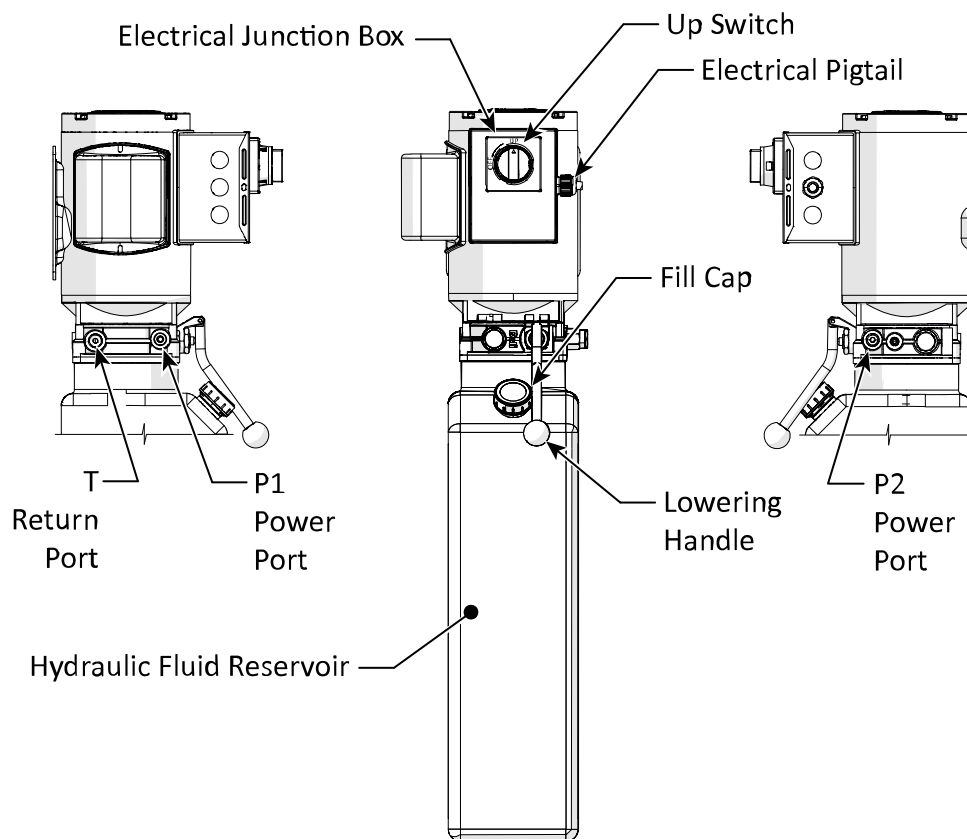

Hydraulic Hose Route Components

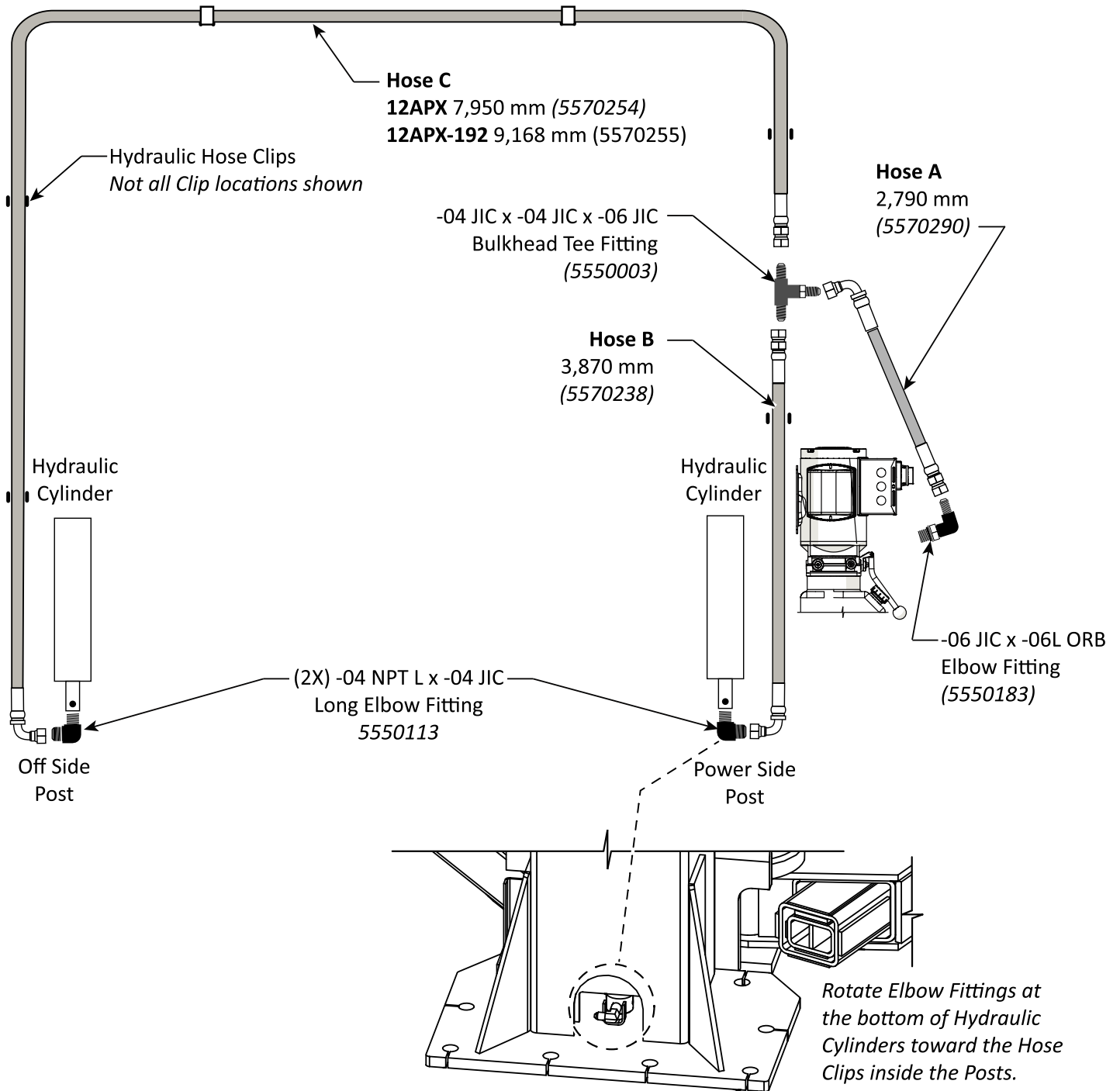

IMPORTANT! Verify all Hydraulic Hoses are seated and secured in the clips on the inside of the Lift Posts and will not interfere with any moving components.

Completed Hose Routing

Power Side Post

Completed Hydraulic Hose Routing shown below. Verify all Cables and Hydraulic Hoses are flat and tight against the Lift Posts. Clear of all moving components inside the Posts.

Secure the Hydraulic Hoses in the Clips. Failure to secure the Hoses in the Clips may result in damaged or ruptured Hydraulic Hoses.

Off Side Post

Bend **all** Clips to secure the Hydraulic Hoses

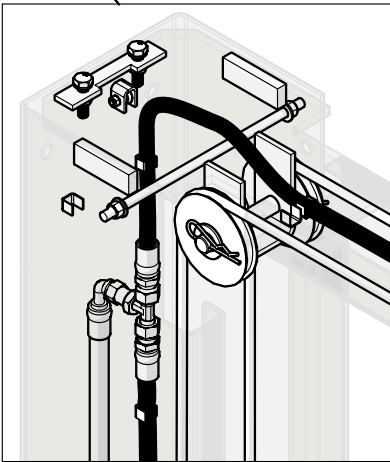

Power Side Post Bulkhead Tee Connections

Power Side Post Connections (Far Side)

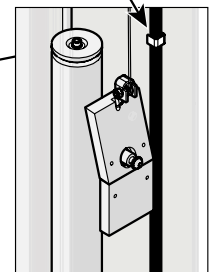
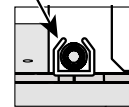
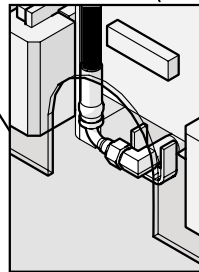

Off Side Post Connections

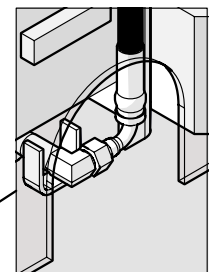

Install the Lift Arms

The 12APX Lift is delivered with four Lift Arms that are installed, as detailed in the following figures. Observe the Front and Rear sides of the Lift as you have chosen to position them:

- If you can only drive in **one way**. The approach side is the Rear, the other side is the Front.
- If you can drive in **either way**. Choose one side as the Front and the other side as the Rear. The rear will be the dedicated approach direction for the Vehicles you will be putting on the Lift; even though you can drive in either way. Also consider the ease of backing out from your chosen approach. Again, you approach the Lift from the Rear, opposite side is the Front.

Next, set into position and install each of the 4 arm assemblies. The front positions hold the respective asymmetric arms, left and right sides.

The remaining two long arms, install to either post in the rear positions.

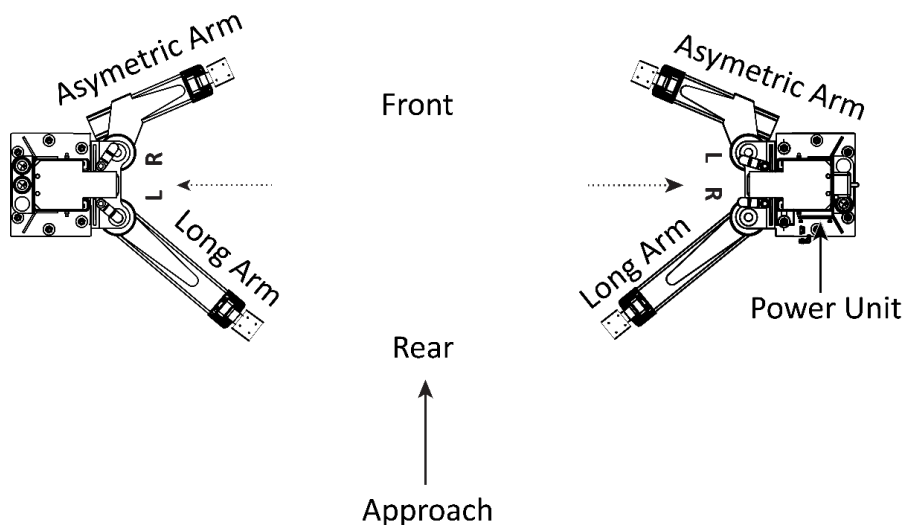

To install a Lift Arm in a Lift Head:

1. Using a Forklift or Shop Crane, raise the desired Lift Head to the first locking position.
2. Loosen the M6 Set Screw and remove the Arm Lock Guide Rod, Release Handle, Compression Spring and Arm Internal Gear Stop.

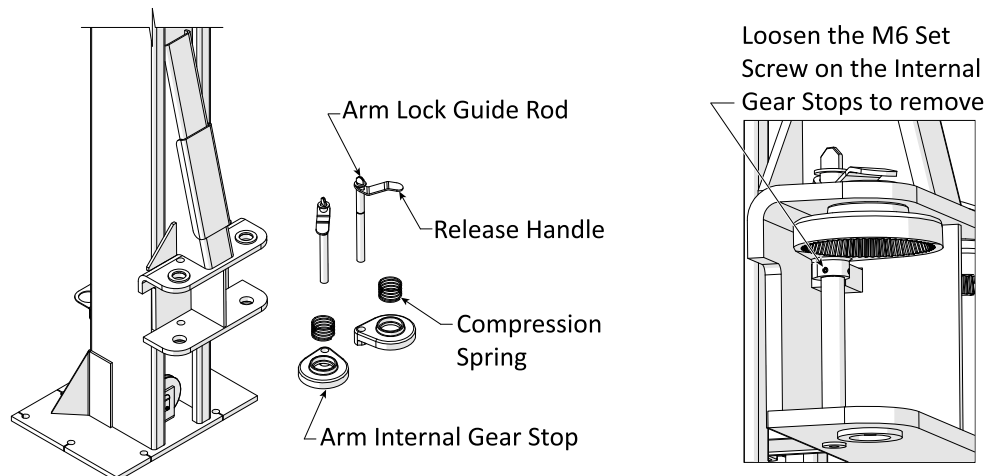

⚠ CAUTION The Lift Head and Lift Arms are heavy. Exercise caution when raising the Lift Head to the first locking position using a Forklift or Shop Crane.

3. Retrieve a Lift Arm Assembly then place a Gear Stop and Spring on the Lift Arm Assembly.

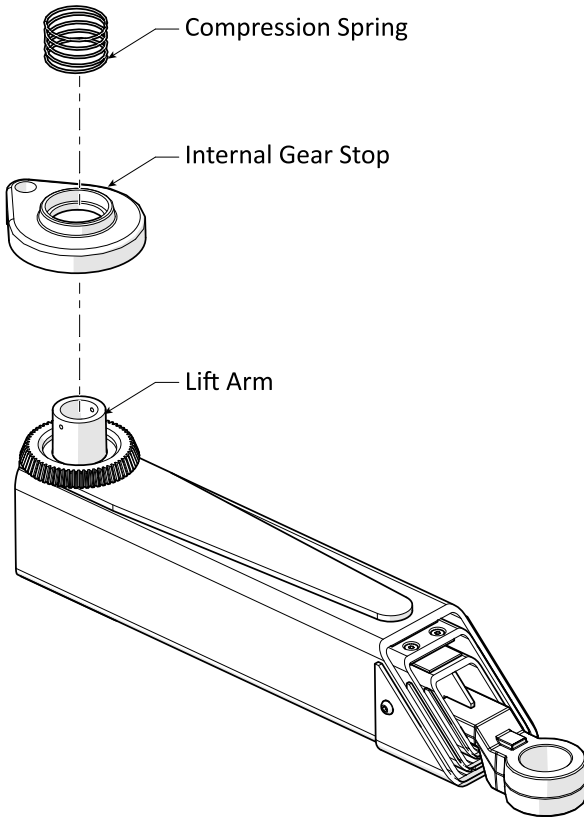

4. Move the Lift Arm with its Gear Stop and Spring into place in the Lift Head, then Slide the Arm Lock Guide Rod with its Arm Lock Release Handle through the holes in the Lift Head and Gear Stop then through the hole at the bottom of the Lift Head.

The Lift Arm openings must be inside the Lift Head and lined up with the holes in the Lift Head.

Reference only – do not scale.

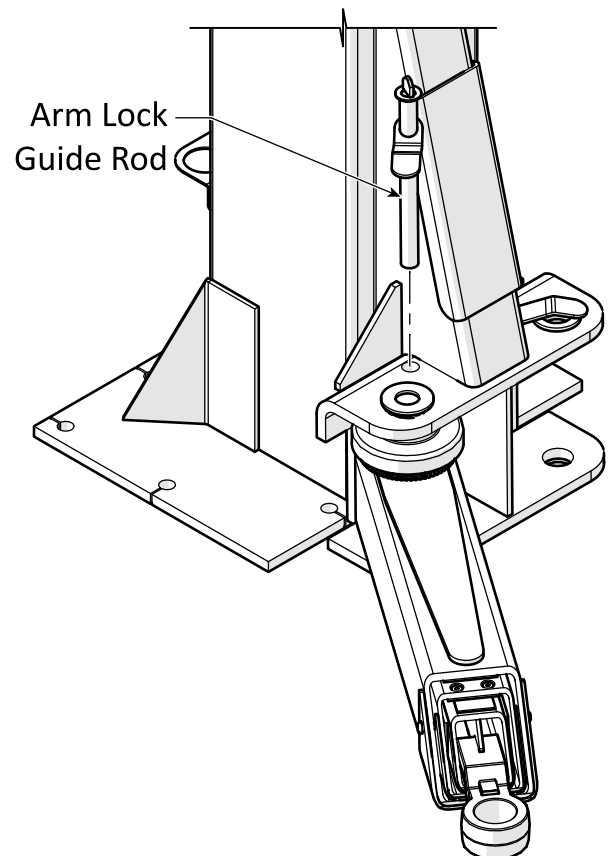

-
5. Tighten the Set Screw into the groove machined into the Arm Lock Guide Rod.

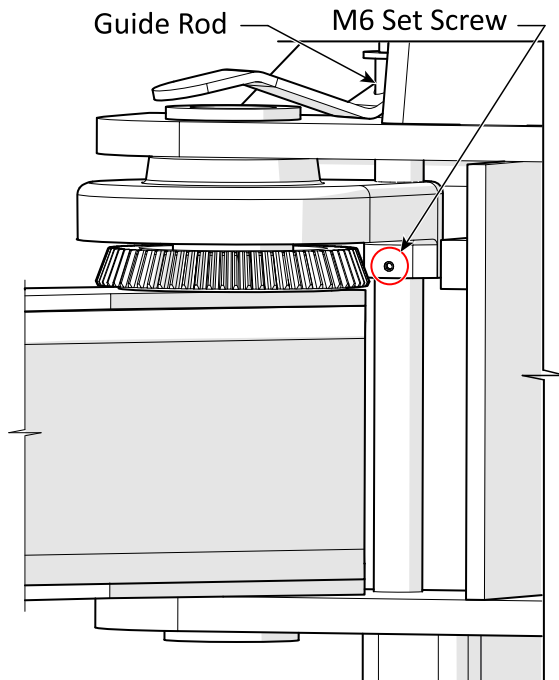

6. Slide the Arm Lock Pin through the holes in the Lift Head and the Lift Arm Assembly.

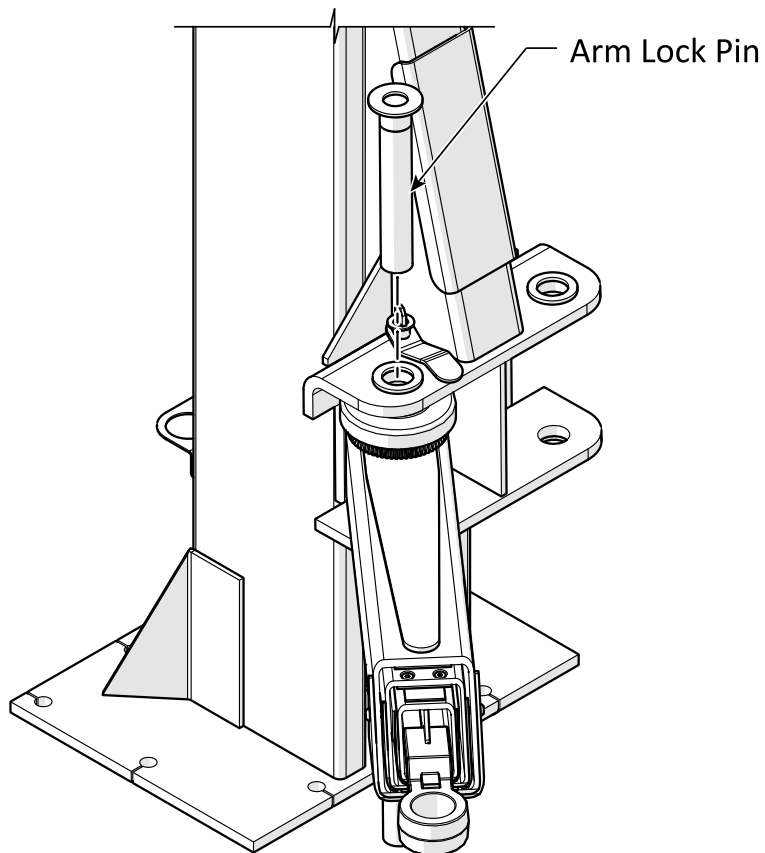

- Secure one M6 Set Screw into the threaded hole on the Arm Mount Tube to secure the Arm Lock Pin.

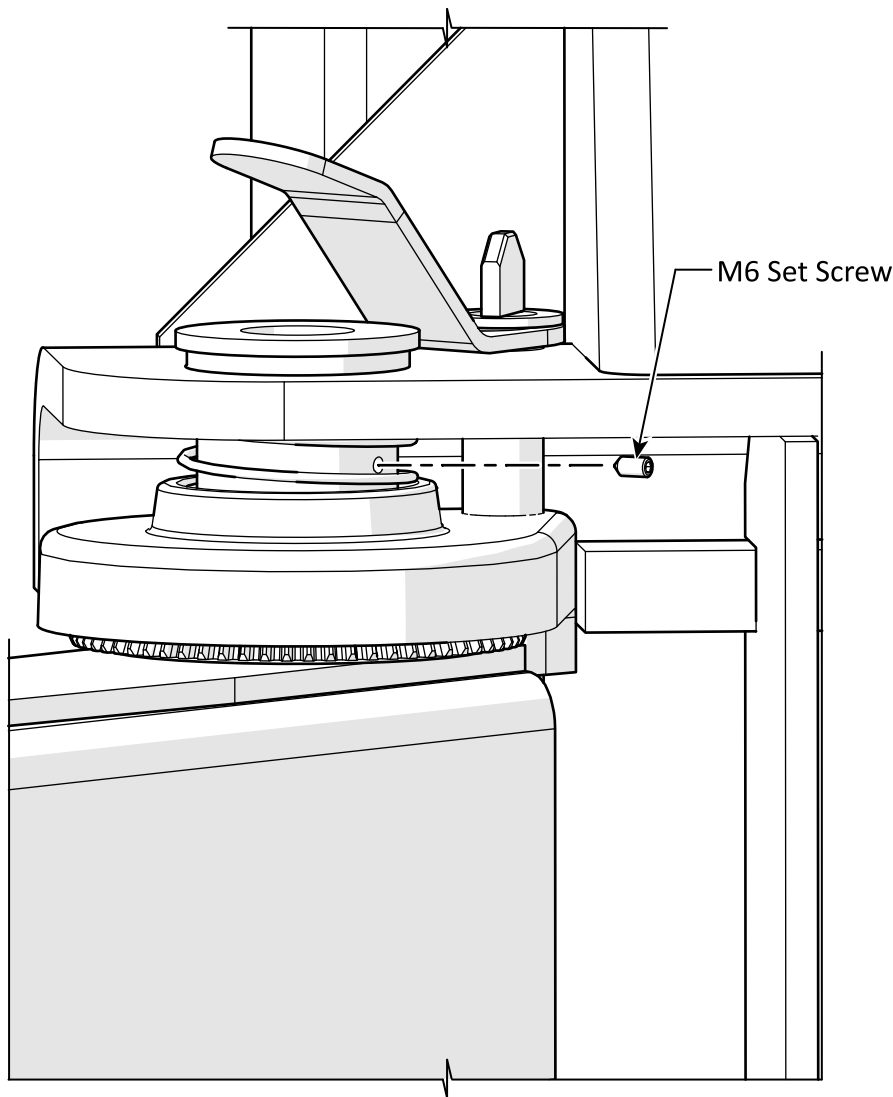

- Repeat Steps 1 – 7 for the remaining three Lift Arm Assemblies.

⚠ WARNING Verify that the Arm Restraint Gears and the Gear Stops are meshing and stay in place when up to 150 pounds of lateral force is applied before putting the Lift into normal operation.

⚠ DANGER Each Lift Arm Assembly **must** be inspected and adjusted as required before each use. Do **not** operate the Lift if any of the four Lift Arm restraint systems are not functioning correctly. Replace any damaged components with approved replacement parts only.

Double Threaded Rod Installation

The Double Threaded Rods (5746167) as shown below, must be installed with M10 flat washers (5545341) and M10 x 1.5 Hex Nuts (5535013) on each Lift Post. Torque the Hex Nuts to 2-3 ft. lb. Hydraulic Hoses are to be routed over the Double Threaded Rods as shown below.

⚠ WARNING The Double Threaded Rods must be installed to ensure proper operation of the Lift.

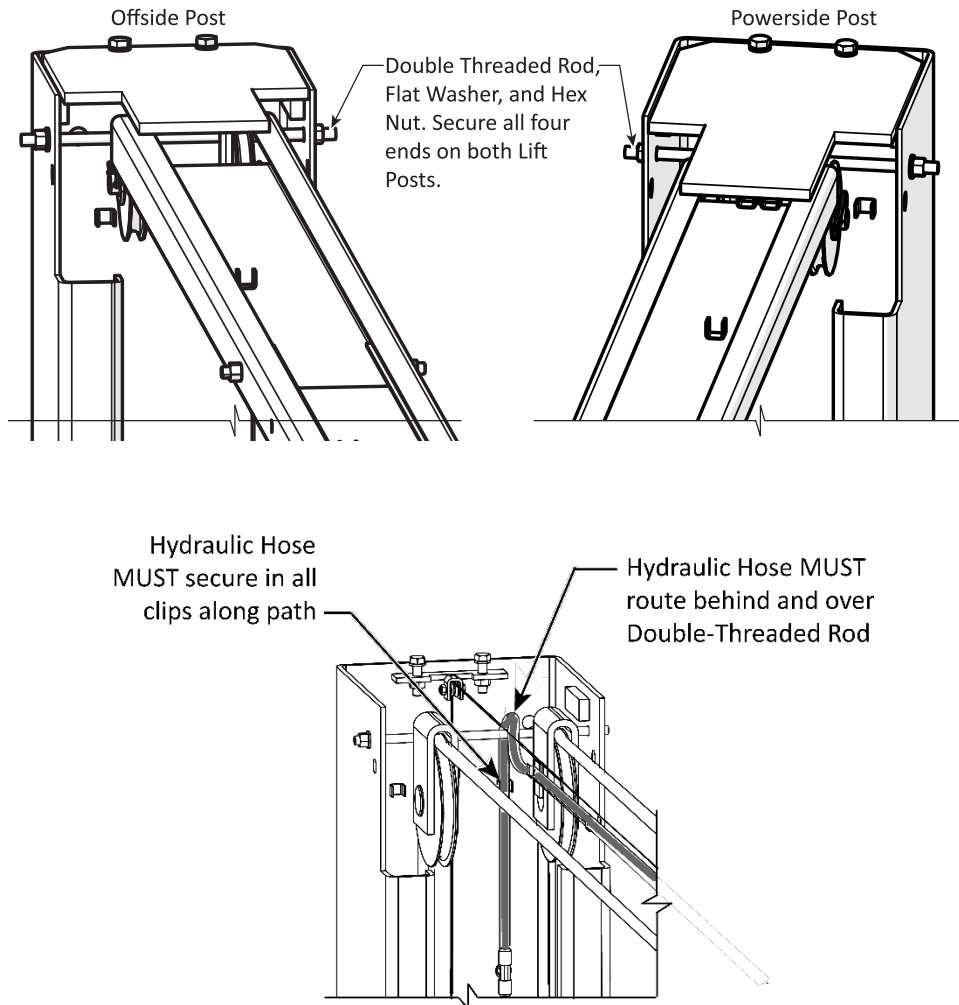

Leveling

Before operating your Lift, verify the Lift Posts are straight, and the Lift Arms are level:

- **Lift Posts:** The Posts **must** be the same distance apart at the top and at the bottom.

Measure the distance between the two Posts six inches below the Overhead Assembly and one foot off the ground (you will need to move the Lift Arms out of the way). The two measurements (**A** and **B** in the figure below) must be the same.

If the Posts are not straight, shim them as required.

⚠ CAUTION If your Lift Posts are not straight or your Lift Arms are not level, this is a safety risk. The Vehicles you put on the Lift will be less secure; they could fall and cause injuries or damage to the Vehicle or to the Lift.

- **Lift Arms:** When the Lift Posts are straight, make sure the Lift Arms are level. Raise the arms to the first locking position and put a level across the Pads.

Adjust the Equalizing Cables. Determine which Lift Arm is low, then adjust the Nut on the bottom of the Threaded End of the Equalizing Cable until the Lift Arms are level. When you believe the Lift Arms to be level, raise the Lift and listen for the Lift Heads passing the Safety Locks (there is a distinct thump). The thumps to be simultaneous or close to it.

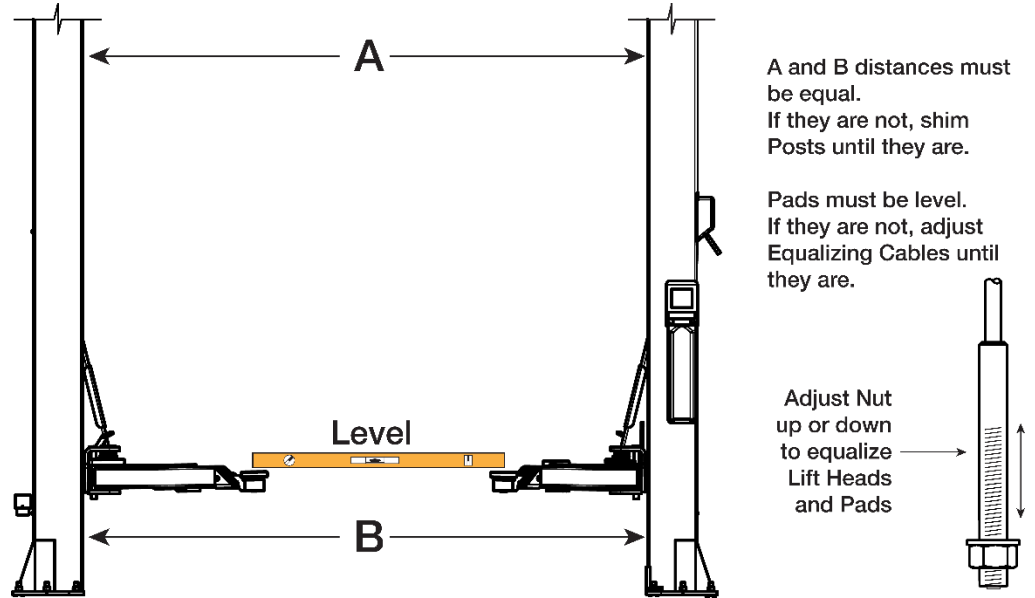

NOTICE

If you have **not** yet torqued the Anchors you can torque them to specification (85 – 95 ft lb.) once you have completed final leveling.

NOTICE

The Equalizing Cables will stretch and should be checked weekly for equal tension. Failure to do so will cause uneven lifting. Cables should always be adjusted so that there is equal tension when resting on the safety locks.

Contact the Electrician

The following installation tasks require an Electrician.

⚠ DANGER All wiring **must** be performed by a licensed Electrician in accordance with all applicable national and local electrical codes.

The Electrician needs to:

- **Connect to power.** The Power Unit comes with a pigtail for wiring to a power source. Have your Electrician connect a power cord with plug to the electrical box on the Lift (for connection to a power outlet) or have them wire it directly into the electrical system at the Lift location.
- **Connect the Limit Switch to the Power Unit.** The Limit Switch (above the Safety Shutoff Bar) must be wired to the Power Unit. The necessary wiring is included.
- **Install a Power Disconnect Switch.** Ensures you can quickly and completely interrupt electrical power to the Lift in the event of an electrical circuit fault, emergency, or when equipment is undergoing service or maintenance. You must put it within sight and easy reach of the Lift operator. Refer to **Installing a Power Disconnect Switch** for more information.
- **Install a Thermal Disconnect Switch**, if required by local electrical code. Refer to **Installing a Thermal Disconnect Switch** for more information.

These installation tasks are described in detail in the following sections.

The Electrician is responsible for providing:

- A power cord and appropriate 220 VAC plug for connecting to a power source or the items required to connect to the facility's power system protected by a circuit breaker or fuse.
- A Power Disconnect Switch.
- A Thermal Disconnect Switch, if required by local electrical code.

Additional information is supplied in the following sections describing these tasks.

Electrical Information

⚠ DANGER All wiring **must** be performed by a licensed Electrician in accordance with all applicable national and local electrical codes. Do not perform any maintenance until main electrical power has been disconnected from the Lift and cannot be re-energized until all procedures are complete.

Important electrical information:

- Improper electrical installation can damage the Power Unit motor, which is not covered by the warranty.
- The Lift uses electrical energy; if your organization has Lockout/Tagout policies, make sure to implement them after connecting to a power source.
- Use a separate circuit breaker for each Power Unit.
- Protect each circuit with a time delay fuse or circuit breaker:
 - 208 to 230 VAC, **single phase** circuit, protected by a 30 Amp time delay fuse or circuit breaker for the 5585685 power unit delivered with the Lift.

Wiring the Overhead Limit Switch

This section describes how to wire the Limit Switch; *installing* the Limit Switch was described in [Installing the Limit Switch](#).

The Lift is delivered with a Limit Switch:

- **Single Phase Power Units require** one Limit Switch, which must be wired between incoming power and the Electrical Box on the Power Unit on one of the two “hot” wires.
- **Three-Phase Power Units require** two Limit Switches, which must be wired between incoming power and the Electrical Box on the Power Unit on two of the three hot legs. Both Limit Switches delivered are identical. If wiring *two* Limit Switches, they **must** be wired on two **different** hot legs. **For Three-Phase Installations see [Three-Phase Limit Switches Installation](#).**

Refer to the diagrams in [Wiring Diagrams](#) for detailed Limit Switch wiring information.

The following procedure assumes the Limit Switch is already in place. If it is not, refer to [Installing the Limit Switch](#) to install it.

 **WARNING** Keep all wiring flat and secured with the cable clips provided in the Lift. Verify all wiring and hydraulic hoses are clear of all moving parts and pinch points.

To wire a Limit Switch on the Lift:

Refer to the figure on the next page.

1. Verify the Limit Switch mounting on the Overhead assembly is on the same side as the power unit. If not, the Overhead assembly must be removed and rotated to place the Limit Switch on the Power Unit side.
2. Locate the 14/2 Limit Switch Cable supplied with the Lift.
3. **On the Overhead Assembly**, connect one end of the Limit Switch Cable to the Limit Switch (or two Limit Switches, for a 3-Phase Power Unit). Refer to [Wiring Diagrams](#) for wiring information.
4. Route the Cable from the Limit Switch through the clips on the Overhead Assembly over the Double Threaded Rod to the Power Side Post, down the inside of the Power Side Post, through the clips, out the Grommet in the Post below the Safety Lock Release, and over to the Electrical Box on the Power Unit. All wiring is to be straight with no slack and secured in the wiring clips. Refer to the figure on the next page.
5. Once the Cable is routed from the Limit Switch to the Power Unit, secure the Cable in the Cable Clips on the Overhead Assembly and inside the Power Side Post. This will secure the cable and keep it clear of any moving Lift components.
6. **On the Power Unit**, open the Electrical Box and connect the Limit Switch Cable as per the instructions found in [Connecting the Power Unit](#).

Important! Verify all Cables and Hoses are tight and flat against the inside of the Lift Posts and routed to avoid interfering with moving components inside the Lift Posts.

 **DANGER** All wiring must be performed by a licensed Electrician in accordance with all applicable national and local electrical codes.

Connecting the Power Unit

The Power Unit and the Limit Switch must be connected to an appropriate power source.

⚠ DANGER All wiring **must** be performed by a licensed Electrician. Do not perform any maintenance or installation on the Lift without first verifying that main electrical power has been disconnected from the Lift and cannot be re-energized until all procedures are complete. If your organization has Lockout/Tagout policies, make sure to implement them after connecting to a power source.

⚠ DANGER Make clear to the Electrician that all electrical work **must** conform to applicable local, state, and federal electrical codes.

⚠ DANGER **Risk of explosion:** This equipment has internal arcing or parts that may spark and should not be exposed to flammable vapors. The Power Unit's motor should not be located in a recessed area or below floor level. Mount the motor at least 18 in. (457 mm) above the floor. Never expose the motor to rain or other damp environments; damage to the motor caused by water is not covered by the warranty.

Your 12APX Series Lift is available with the following Power Unit: **208-230VAC, 60 Hz, 1 Phase, 5 HP, 23 Amps (5585685)**

NOTICE 110 VAC Power Units are currently **not** available for 12APX Series Lifts.

To install Three-Phase Power units see [Three-Phase Power Unit Wiring](#).

The following drawing is a front view of a Power Unit. Your specific Power Unit may look different based on what type you purchased.

Note: The **Up** Switch shown in the drawing below may be in a different location on the unit or could be a pushbutton instead of a rotary switch, depending on the Power Unit you have.

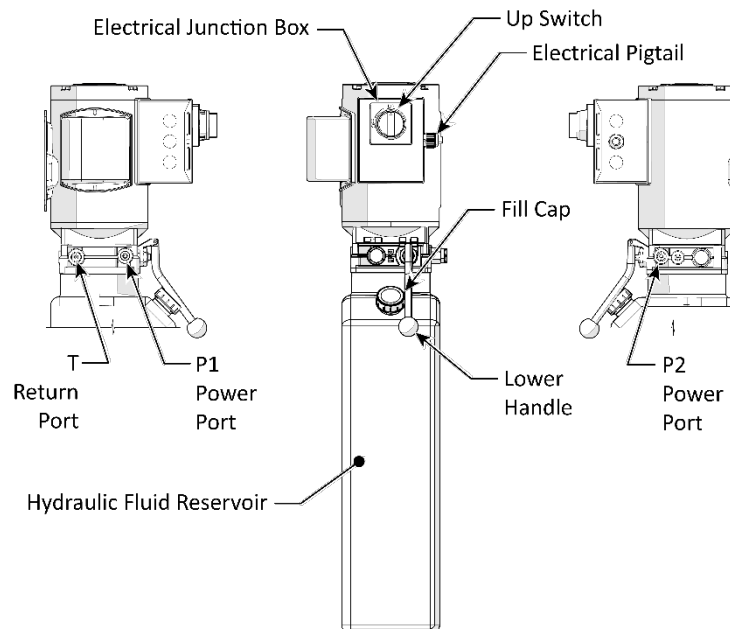

NOTICE Wiring information is either on the outside of the Power Unit under the Electrical Junction Box or inside the cover of the Electrical Junction Box. Have the Electrician use that wiring information to wire the Power Unit to the power source.

To prepare the Power Unit:

1. Have the Electrician locate the Pigtail exiting of the Electrical Junction Box on the Power Unit.
2. Open the Electrical Junction Box, remove the Pigtail, and then either:
 - Wire the Power Unit directly into the facility's electrical system and protected by an appropriate circuit breaker or time delayed fuse.
 - Wire a power cord (with appropriate plug) *inside the Electrical Junction Box* to the wiring that was connected to the Pigtail.
3. Wire the Limit Switch(es) into the incoming power. Refer to **Wiring Diagrams** for wiring information.
4. Fill the Hydraulic Fluid reservoir with approved Hydraulic Fluid.

The reservoir holds **≈3.5 gallons** of Hydraulic Fluid, depending on which Power Unit you have.

Approved Hydraulic Fluids are any general-purpose ISO-32, ISO-46, or ISO-68 hydraulic oil or approved automatic transmission fluids such as Dexron III, Dexron VI, Mercon V, Mercon LV, Shell Tellus S4 / S3 / S2, or any synthetic multi-vehicle automatic transmission fluid.

 **WARNING** Do not run the Power Unit without Hydraulic Fluid; you will damage it.

 **WARNING** Running high electrical current that exceeds the motor's full load amps (FLA) rating may result in permanent damage to the motor. BendPak strongly recommends you **do not** exceed the rated duty cycle of the Lift motor.

Installing a Power Disconnect Switch

⚠ WARNING A Power Disconnect Switch is **not** provided with this equipment.

A Power Disconnect Switch is a National Electrical Code (NEC) requirement. They are designed to allow the operator to interrupt the main electrical power in the event of an emergency or circuit fault, or when the equipment is undergoing service or maintenance.

Make sure to install a Power Disconnect Switch that is properly rated for the incoming power source.

Your Power Disconnect Switch must be readily accessible and installed so that it is in easy reach of the operator or in their line of sight. The Power Disconnect Switch must be clearly marked to indicate its purpose.

The figure to the right details a Power Disconnect Switch located between the Lift's power source and its Power Unit. A quick flip of the switch immediately cuts power to the Lift.

On 12APX Series Lifts, the location directly above the Power Unit is used by the Lowering Handle, so your Electrician may want to move the Power Disconnect Switch location up to accommodate.

⚠ DANGER Installing a Power Disconnect Switch **must** be performed by a licensed Electrician in accordance with local and national electrical codes.

Have the Electrician select a **UL-listed** Power Disconnect Switch.

Installing a Thermal Disconnect Switch

The Power Unit supplied with this Lift **does not** include thermal overload protection. Under NEC 430, UL 201, and CSA C22.2 No. 68 intermittent duty motors are not required to include thermal protection. Local electrical codes may vary, and other requirements may exist that the installing electrician will address, if required.

⚠ DANGER If local Electrical codes require the installation of a Thermal Disconnect, the disconnecting device and the installation **must** be provided by a licensed Electrician in accordance with local electrical codes. Do not perform **any** maintenance or installation on the Lift without first verifying that main electrical power has been disconnected from the Lift and **cannot** be re-energized until all procedures are complete.

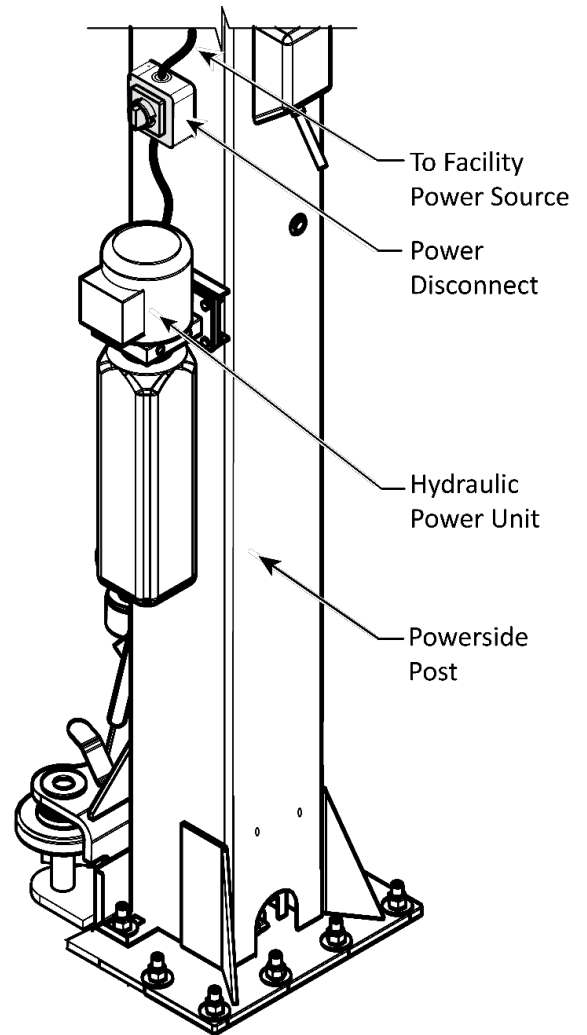

Lubricating the Lift

Lubricate the following with a white lithium grease or similar:

- All Cable Sheaves and Cable Sheave Pins
- The four inside corners of both Posts
- Safety Sheaves
- All Lift Arm Pivot Points

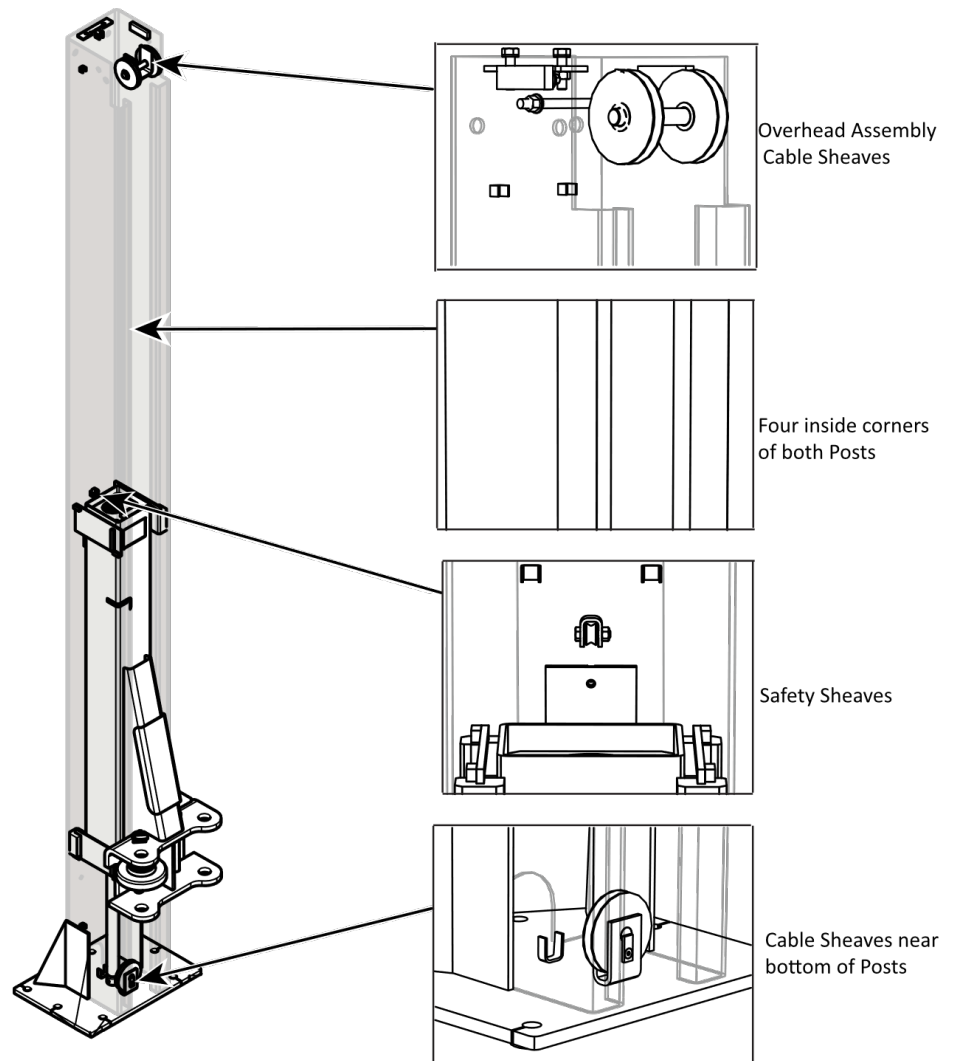

Some Components Removed for Clarity

Review Final Checklist Before Operation

Make sure these things have been done before putting the Lift into normal operation:

- Review the **Installation Checklist** and verify all steps have been performed.
- Make sure the Power Unit is getting power from the power source.
- Check the Hydraulic Fluid reservoir; it must be full of approved Hydraulic Fluid or automatic transmission fluid. **You can damage the motor by running it without enough fluid.**
- Check the Hydraulic System for leaks. Verify all Hydraulic Hose connections, Hydraulic Fittings, and Auxiliary Port Plugs on the Lift and Power Unit are tight.
- Make sure both Posts are properly plumbed, shimmed, and stable.
- Check to see that all Anchor Bolts are correctly torqued.
- Lubricate all Cable Sheaves and the inside of the Posts where the Slide Blocks move.
- Verify both Double Threaded Rods are in place and tightened near the top of both Posts.
- Verify all Cables are properly positioned in their Sheaves.
- Verify sure all Cable Sheave retaining pins and/or clips are secure.
- Verify both Safety Assemblies are connected and working normally.
- Verify the Cylinder Clamps are secured in place above the Hydraulic Cylinders.
- Verify that all Safety Locks are clear and free.
- Verify an Operational Test has been performed.

Leave the Manual with the Owner/Operator

Leave the *Installation and Operation Manual* with the owner/operator so that it is available to everyone who is going to use the Lift.



Perform an Operational Test

Before putting your Lift into normal operation, we recommend raising and lowering it several times with a typical Vehicle on the Lift. This will help you get a feel for how to operate the controls and help get any residual air out of the Hydraulic System (sometimes called “bleeding” the system).

⚠ DANGER Automotive Lifts are dangerous tools when used by inexperienced or impaired technicians. Remember that lifting a Vehicle is a serious endeavor with life-threatening risks if lifting precautions are ignored.

During the Operational Test, check for proper installation and operation. Do not raise any additional Vehicles until a thorough Operational Test has been completed with a typical Vehicle.

⚠ WARNING Never raise a Vehicle whose weight exceeds the rated capacity of the Lift. Do not leave the controls until the Lift is engaged on its Safety Locks. Only trained personnel should raise or lower the Lift.

To perform an Operational Test:

1. Make sure you have covered all the areas in **Review Final Checklist before Operation** before proceeding further.
2. Follow the instructions in **Raising a Vehicle** and **Lowering a Vehicle** to safely raise and lower a Vehicle on the Lift.

⚠ DANGER Follow the instructions carefully when it comes to contacting the manufacturer's recommended Lifting Points on the underside of the Vehicle. If you do not, the Vehicle could become unstable and fall, which could damage the Vehicle, damage the Lift, and injure or even kill anyone under the Vehicle.

3. Adjust the Lift Arms under the Vehicle so the Adapters are directly under the Lifting Points for the Vehicle you are raising. If necessary, use Auxiliary Adapters (accessories available separately) for extra height.
4. Press the **Up** button to raise the Lift until **just before** the Adapters contact the Lifting Points.
5. Check the Arm Restraint Gears on all four Lift Arm Assemblies to make sure they are engaged. If they are not engaged, move the Lift Arms back and forth until they engage.
6. Raise the Lift until the tires of the Vehicle are a few inches above the ground.
7. Verify all four Adapters are making solid contact with all Lifting Points.

If any of the Adapters are **not** making solid contact with the Lifting Points, carefully lower the Lift and start over again; the Adapters **must** make solid contact with all Lifting Points.

8. Raise the Vehicle approximately three feet off the ground, then release **Up**, then *press and hold* the Safety Lock Release Handle and the Lowering Handle to lower the Lift back down.

NOTICE Residual air in the Hydraulic System can cause the Lift to shake, move erratically, or squeak; this is normal when you first start using the Lift. It will soon stop doing this, as the Hydraulic System is self-bleeding.

9. Wait for one minute.

⚠ WARNING The Power Unit is not a constant duty motor; **do not run continuously**.

10. Repeat the process, this time raising the Lift, engaging it on a Safety Lock position, taking it off the Safety Lock position, and then lowering it back down to the ground.
11. If the Lift is working without shaking, moving erratically, or squeaking, there is no need to repeat the procedure. If the Lift is shaking, moving erratically, or squeaking, repeat the procedure one more time. If you continue to have issues, refer to **Troubleshooting** for assistance.
12. When the Lift is on the ground and the Vehicle is on all four tires, move the four Lift Arms to their full drive-through positions, then drive the Vehicle out.
13. With no Vehicle on the Lift Arms, press and hold the **Up** button on the Power Unit.
14. Have another person push up the Safety Shutoff Bar with a broom or long pole until it triggers the Limit Switch.

If the Lift Arms do not stop rising when the Limit Switch is triggered, this means the Limit Switch is either not installed correctly or not wired correctly. Return to the sections in this manual where installation and wiring of the Limit Switch is described to identify and correct the issue.

⚠ CAUTION Do not put the Lift into normal operation until you have confirmed that triggering the Limit Switch stops the Lift Arms from rising.

Operation

This section describes how to operate your BendPak 12APX Series Lift.

 **DANGER** Automotive Lifts are dangerous tools when used by inexperienced or impaired technicians. Lifting a Vehicle is a serious endeavor with life-threatening risks if mandatory lifting precautions are ignored.

Lift Operation Safety Rules

 **DANGER** Your safety depends on reading, understanding, and implementing these Safety Rules. Do not skip over them; read them carefully and follow them!

Do the following **before** you raise or lower a Vehicle on your Lift:

Check the Lift. A complete inspection of the Lift is required before using it. Check the Hydraulic System for loose connections including Hydraulic Fittings, Hydraulic Hoses, and any Auxiliary Port Plugs. Check the Lift for any missing, heavily worn, or damaged parts. Do not operate the Lift if you find any issues; instead, take it out of service, contact your dealer, email support@bendpak.com, or call **(800) 253-2363**, option 7 then 4.

- **Check the area.** Keep the area around the Lift clean and free of obstructions; anything that could cause a problem for the Lift. Do not forget to check **above** the Lift. If you find an obstruction, move it out of the way. Do not allow any people or animals within 30 feet of the Lift while it is in motion.
- **Check the operators.** Make sure that everyone who is going to operate the Lift has been trained in its use, has read the labels on the unit, and has thoroughly read the manual and understands how this equipment works. Only the operator should be within 30 feet of the Lift when it is in motion. Do not allow children to operate the Lift. Do not allow anyone under the influence of drugs or alcohol to operate the Lift.
- **Check for safety.** Make sure everyone who is going to be walking near the Lift is aware of its presence and takes appropriate safety measures. Only put Vehicles on the Lift Arms. **When raising a Vehicle on the Lift, do not leave it until it is positioned on Safety Locks.** When lowering the Lift, do not leave it until it is on the ground.
- **Check the Vehicle.** Never exceed the Lift's weight rating. Do not allow people inside a Vehicle you are going to raise. Make sure the Vehicle is not overbalanced on either end. Make sure you know the manufacturer's recommended Lifting Points for the Vehicle. Never raise just one side, one corner, or one end of a Vehicle.

 **WARNING** Always use care when you are around your Lift. When it is in a lowered position, be careful not to trip over it. When it is raised, be careful not to hit your head on the Lift Arms or the Vehicle. **When you are raising or lowering a Vehicle, keep all personnel and objects at least 30 feet away from the Lift.**

About Lifting Points, Adapters, and Auxiliary Adapters

A crucial point to keep in mind when using a frame-engaging Lift is that the raised Vehicle must be balanced on the four Lift Arms. If the Vehicle is not balanced, it is more likely to become unstable and slide off the Lift, possibly damaging the Lift, the Vehicle, and anything under the Lift, including injuring people.

⚠ WARNING You **must** use all four Lift Arms when raising a Vehicle. Never use just one, two, or three Lift Arms to raise a Vehicle. The Vehicle will be unstable and could slip off the Lift, possibly damaging the Lift, damaging the Vehicle, and injuring anyone under it.

To balance a Vehicle on a frame-engaging Lift, you need to have the Adapters (also called Pads) contact the Vehicle on the manufacturer's recommended Lifting Points. When you raise a Vehicle by its Lifting Points, the Vehicle is balanced.

NOTICE The manufacturer's recommended Lifting Points do not take into consideration any major changes that might have been made to the Vehicle. If the motor is removed, for instance, or there is heavy weight in the trunk, the Vehicle's Lifting Points will not be the best balancing points.

Some Vehicles have indicators on the underside that identify the Lifting Points; many do not.

Your best approach is to find the Vehicle in the guide provided with your Lift. *Vehicle Lifting Points for Frame Engaging Lifts* or contact the manufacturer of the Vehicle. This guide also includes a page of safe lifting suggestions, which everyone who uses the Lift should read.

Lifting it Right: A Safety Manual from the Automotive Lift Institute, also provided with your Lift, includes a variety of information about Lifts and how to use them safely.

⚠ DANGER **Never** place any Contact Pads on non-approved, non-load holding Sill Covers or Side Skirts!

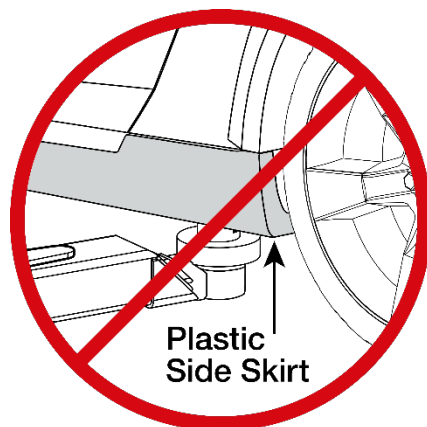

Accessories

Included with the 12APX Lift are **Four Medium Auxiliary Adapters - 2.50 in. (63 mm)** (5746192) and **Four Tall Auxiliary Adapters - 5.00 in. (125 mm)** (5746193). Additional sets are offered to allow you to position the height of the Auxiliary Adapters to make better contact with Vehicles.

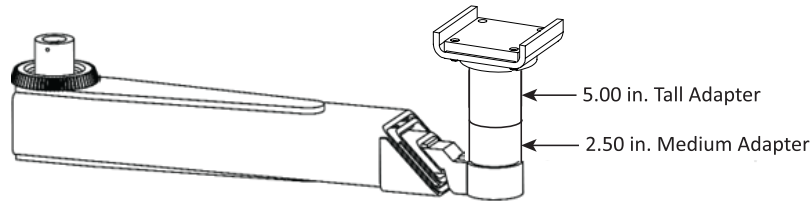

The 12APX Lift also includes **Frame Cradle Adapters** — Required for use on Perimeter Frames when lifting trucks, vans or other frame Vehicles that require additional stability. Set of 4 (5215761). Additional sets are also offered.

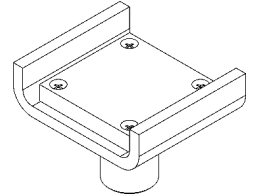

Optional Accessories

(Not included with the 12APX)

- **Four Tall Auxiliary Adapters - 5.00 in. (125 mm)** (5746193). Allows you to position the height of the Auxiliary Adapters to make better contact with Vehicles. (Set of 4 sold separately)
- **Four Medium Auxiliary Adapters - 2.50 in. (63 mm)** (5746192). Allows positioning the height of the Auxiliary Adapters to optimize contact with Vehicles. (Set of 4 sold separately)

⚠ WARNING You can stack Auxiliary Adapters, but only up to 9 in. If you stack Auxiliary Adapters above 9 in., the Vehicle could become unstable and slip off the Lift, possibly damaging the Lift, damaging the Vehicle, and injuring anyone under it.

- **SUV and Van Adapters** — Recommended for Trucks, SUVs, and Vans requiring additional lifting height.

56 mm (5746007)

63 mm (5746192)

125 mm (5746193)

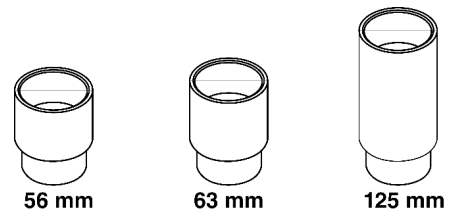

⚠ WARNING Use the correct Adapters. Do not attempt to lift trucks or other frame type vehicles with standard Rubber Contact Pads.

Quick-Fit Slotted Pinch-Weld Pucks or Pads — Always use slotted Pinch-Weld Pucks (5210263) or slotted Pinch-Weld Pads (5210254) when lifting Vehicles on Manufacturer Approved Pinch-Weld Jacking Points. These convenient tear-resistant urethane Adapters simply fit over the existing round Contact Pads.

- **Wide Frame and Super Wide Frame Cradle Adapters** — Recommended for use when lifting heavy-duty wide frame vehicles.
- **Wide Frame** version fits frames up to 5.25 in. (133 mm) (5215828) wide, Set of 2.
- **Super Wide Frame** version fits frames up to 6.5 in. (168 mm) (5210253) wide, set of 2.

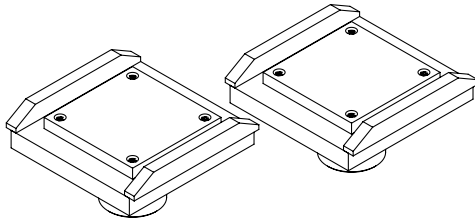

Wide Frame Cradle Adapter

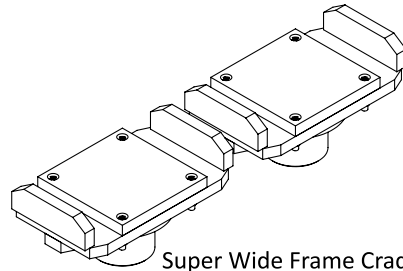

Super Wide Frame Cradle Adapter

- **Cradle Lift Pad** — Wide Polyurethane Pad, set of 4 pads (5210231).

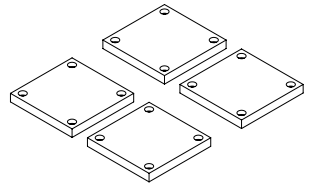

- **Steel Lift Pads** — Recommended for additional stability on all vehicles. The flanged edges grip the chassis for an extra-secure hold. (5215692)

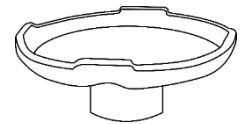

You may contact BendPak for accessories and replacement Parts information at **(800) 253-2363**, press option 7, then 5; please have the model and serial number of your Lift available. Visit bendpak.com for additional Adapters and Auxiliary Adapters (also called height adapters or extenders).

Raising a Vehicle

This section describes how to raise a Vehicle on your 12AP Series Two-Post Lift.

⚠ WARNING Never raise a Vehicle whose weight exceeds the rated capacity of the Lift. Do not leave the controls until the Lift is engaged on a Safety Lock position or fully lowered. Only trained personnel should raise and lower the Lift.

⚠ WARNING Always stay within the Safe Operator Area when using the Lift. Refer to the figure below. The safe operator area will keep the operator clear of crushing, shear and pinch points while providing an unobstructed line of sight to the vehicle and access to the Lift Controls. Personnel near the Lift but outside of the Safe Operator Area should be moved clear of the lift by a minimum of 30 ft. (9 m).

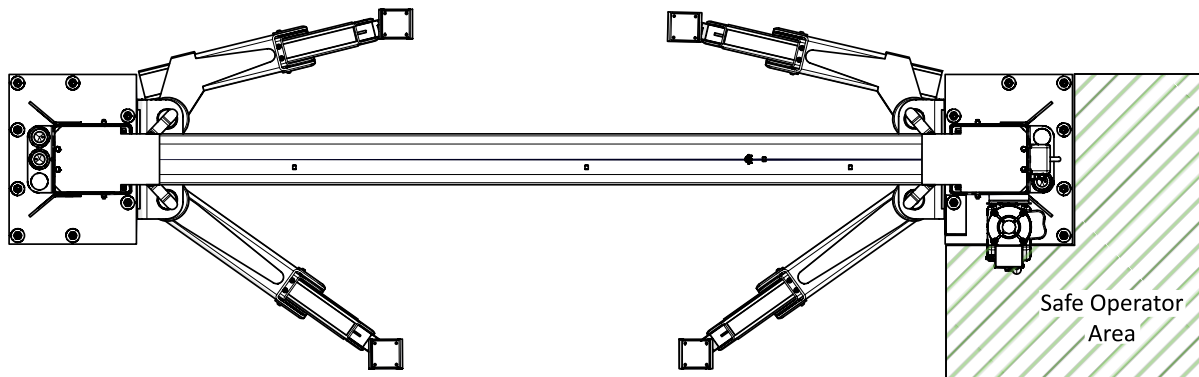

To raise a Vehicle:

1. Verify all four Lift Arms are on the ground in their full drive-through positions and all personnel are clear of the service bay.
2. Check under the Vehicle you are going to raise, check for the type of vehicle frame, and then put the most appropriate Adapters on the Lift Arms.

If you are lifting a sedan or a Vehicle with a unibody construction, a Screw Lift Pad is generally the best choice. If you are lifting an SUV, truck, or other Vehicle with a frame construction, a Frame Cradle Pad is often the best choice.

⚠ WARNING Always use the Adapter type best suited for the Vehicle you are raising. If you use the wrong Adapter type, the Vehicle could become unstable.

3. Drive the Vehicle into the service bay.

⚠ CAUTION When driving a Vehicle into position, keep to the middle area between the Posts. If you hit a Lift Arm or any other portion of the Lift, you could damage the Vehicle and/or the Lift.

4. When you are satisfied with the location of the Vehicle, put it in park, put on the parking brake, and turn off the motor.

If the Vehicle is a manual transmission, put it into first gear before turning off the motor.

5. Get out of the Vehicle; open the doors carefully to avoid damaging them on the Lift.
6. Locate the manufacturer's recommended Lifting Points for the Vehicle you are raising.

If you are unsure where the Lifting Points are, consult *Vehicle Lifting Points for Frame Engaging Lifts*, which was provided with the Lift, or the manufacturer of the Vehicle. If you no longer have

Vehicle Lifting Points for Frame Engaging Lifts, contact BendPak Support email support@bendpak.com or call **(800) 253-2363**, option 7, then 4, to secure a replacement copy.

Some Vehicles may have the manufacturers' recommended Service Garage Lift Point locations identified by a triangle mark on the underside of the Vehicle, reference SAE J2184- (Current Edition). On some Vehicles, specific Lifting Points are indicated by a label located on the driver's side door jamb.

⚠ WARNING Do not estimate the best location for the Adapters. **You must use the manufacturer's recommended Lifting Points.** If you do not, the Vehicle could become unstable and fall, which could damage the Vehicle, damage the Lift, or injure or even kill anyone under the Vehicle.

⚠ WARNING Many specialty or modified Vehicles or Vehicles with unusually short or long wheelbases cannot be on raised on a Two-Post Frame Engaging Lift. Contact the Vehicle's manufacturer for Raising or Jacking guidance.

The following figure illustrates typical lifting points based on Vehicle Frame type.

Typical Lifting Points

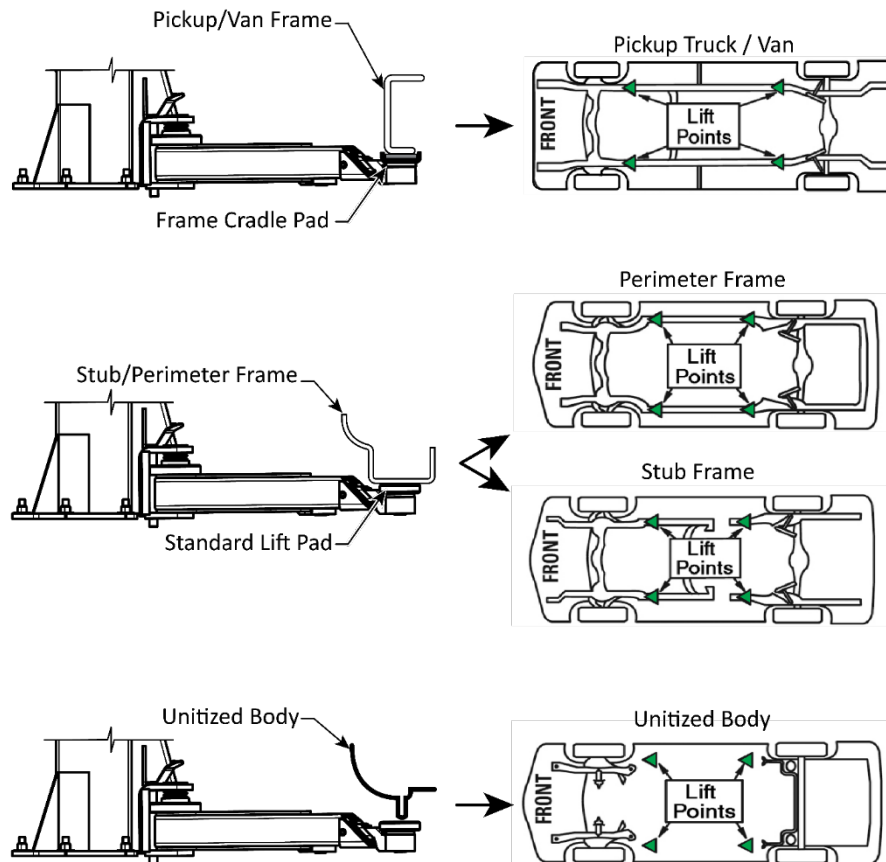

⚠ WARNING Before attempting to lift a Vehicle verify:

- The Vehicle Frame is strong enough to support its weight and has not been weakened or compromised by modification, damage, or corrosion.
- The Vehicle individual axle weight does not exceed one-half the Lift capacity.

- All- Lift Adapters are in secure contact with the Frame at the Vehicle manufacturers' recommended Lift Points.
- The Vehicle is stable on the Lift and the center of gravity is not shifted, making the Vehicle off balance.
- The overhead switch bar will contact the highest point on the Vehicle.

⚠ WARNING Always use Safety Stands when removing or installing heavy components that may affect the Vehicle's Center of Gravity.

7. Adjust the Lift Arms under the Vehicle until the Adapters are **directly under** the Lifting Points for the Vehicle you are raising. If necessary, use the included Auxiliary Adapters for extra height.

The Vehicle's Lifting Point locations and Center of Gravity will determine if the Lift is configured in an Asymmetric or Symmetric Configuration.

In an Asymmetric Configuration the Centerline of the Vehicle is behind the Lift Posts.

In a Symmetric Configuration the centerline of the Vehicle is lined up at the Lift Posts.

Refer to the figure below.

Asymmetric Configuration

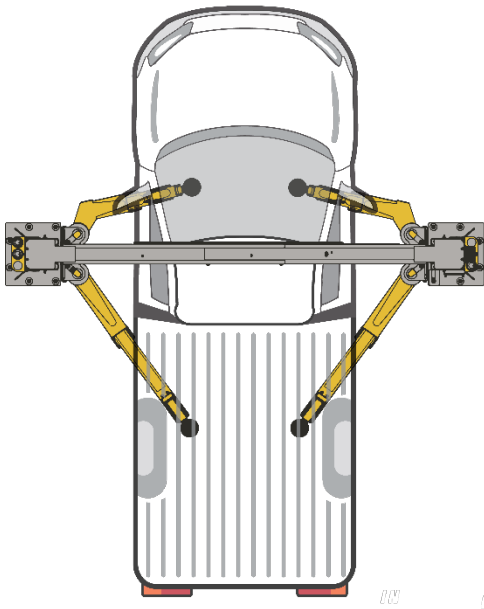

Symmetric Configuration

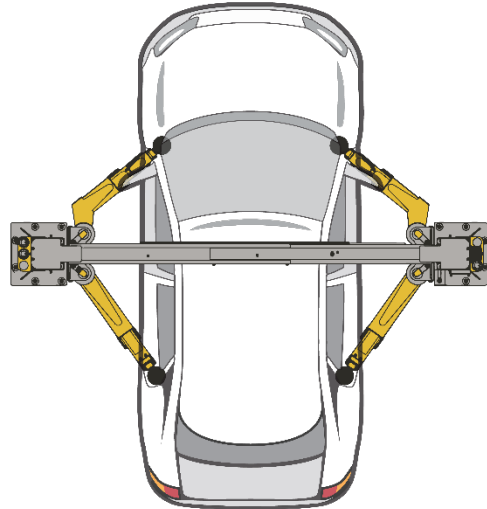

Reference only – do not scale.

8. Raise the Lift until **just before** the Adapters contact the Lifting Points.
9. Check the Arm Restraint Gears on all four Lift Arms to make sure they are engaged.
If they are not engaged, move the Lift Arms back and forth until they engage.
10. Raise the Lift until the tires of the Vehicle are a few inches off the ground.
11. Verify all four Adapters are making solid contact with the Lifting Points.

If any of the Adapters are **not** making solid contact with the Lifting Points, carefully lower the Lift and start over again; the Adapters **must** make solid contact with all Lifting Points.

12. Gently rock the Vehicle to make sure the Vehicle is stable and balanced.

- If the Vehicle is **not** stable and balanced, lower the Lift back to the ground and start over.
- If the Vehicle **is** stable and balanced, raise it to the desired height.

 **DANGER** Do not raise the Lift farther until the Vehicle on the Lift is both stable and balanced. If the Vehicle is **not** stable and balanced, it could fall, which could damage the Vehicle, damage the Lift, as well as injure or kill anyone under the Vehicle.

 **WARNING** Ensure personnel and objects are always clear of the Lift when operating. Always keep a clear line of sight on the Lift.

 **WARNING** Remain Clear of the elevated Lift until visual confirmation is made that all Safety Locks are fully engaged, and the Lift is lowered onto the Safety Locks.

13. Press and hold the **Up** Button.

14. Listen as the Lift passes the Safety Locks; you should hear a thump as each side passes by the Safety Locks at approximately the same time.

15. When the Vehicle reaches the desired height, go past the next Safety Lock position (you will hear the thump as it passes), then release the **Up** Button.

16. *Press and hold* the Lowering Handle, which lowers the Lift onto the Safety Lock position you just passed. Do **not** hold the Safety Lock Release Handle while lowering onto the Safety Locks.

17. When the Lift stops moving down, it is engaged on its Safety Locks; release the Lowering Handle.

Do not leave the Lift controls unless the Lift is engaged on its Safety Locks or fully lowered.

18. Recheck the Adapters to verify they are all still making solid contact with the Lifting Points.

19. Verify the Lift is engaged on the **same Safety Lock** on both Posts.

 **DANGER** Always ensure both Safety Locks are engaged. If the Lift Heads are engaged on Safety Locks at two different heights or only one Safety Lock is engaged, the Vehicle could become unbalanced and fall causing damage, injury, or death.

20. Support the vehicle with Jack Stands in case the vehicle becomes unbalanced while working.

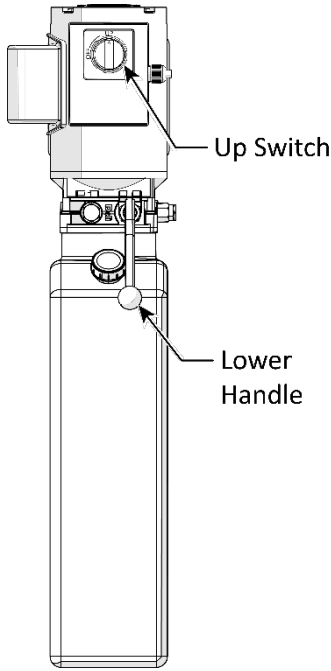
<p>To raise the Lift:</p> <ol style="list-style-type: none"> 1. Rotate and hold Up Switch. 2. When Lift is just past desired height, release the Up Switch. 3. Press and hold Lowering Handle. <p>Do not pull down the Safety Lock Release Handle. If you do, the Lift will continue to lower and will not engage on its Safety Locks.</p> <p>The Lift will engage on a Safety Lock and stop moving; release Lowering Handle when Lift stops.</p> <p><i>Only leave Lift on Safety Locks or fully lowered.</i></p>	 <p>The diagram shows a vertical lift column. At the top, there is a control panel with a circular 'Up Switch' and a 'Lower Handle' located on the side of the column. Arrows point from the text labels to the corresponding parts in the diagram.</p>	<p>To lower the Lift:</p> <ol style="list-style-type: none"> 1. Rotate and hold Up Switch for two to three seconds. This moves Lift off its Safety Locks. 2. Pull down and hold Safety Lock Release Handle <i>and</i> Lowering Handle simultaneously. The Lift begins to lower. 3. When Lift is fully lowered, release the Safety Lock Release Handle and Lowering Handle. <p><i>Only leave Lift on Safety Locks or fully lowered.</i></p>
---	---	---

Lowering a Vehicle

To lower a Vehicle off the Lift, first raise it a small amount to get it off its Safety Locks, then lower it.

To lower a Vehicle off the Lift:

1. Check under and around the Vehicle to make sure the area is clear of all obstructions. If you find any obstructions, **move them out of the way**. Verify all personnel are well clear of the Lift.
2. Press and hold the **Up** Button for a second or two to move the Lift off its Safety Locks.
Raise the Lift at least two inches to get clear of the Safety Locks.
3. Pull down and hold the Safety Lock Release Handle (on the Power Side Post above and to the right of the Power Unit).
4. Push and hold the Lowering Handle (on the front of the Power Unit). The Lift begins lowering.

NOTICE

Both the Safety Lock Release Handle **and** the Lowering Handle must be held down at the same time to lower the Lift.

WARNING

Do not override the Lift controls. For safety purposes, Lift controls are designed to stop the Lift if released. Overriding the Lift controls could lead to damage to the Lift, damage to the Vehicle on the Lift, injury, or in rare cases, death to persons nearby.

CAUTION

Remain clear of the Lift as it comes down; obey the pinch point warning decals.

5. When the Lift is on the ground, release both Handles, then rotate all four Lift Arms to their full drive-through positions to allow an unobstructed exit for the Vehicle.
6. Carefully drive the Vehicle out.

About Safety Locks

A Safety Lock **position** is defined as when the Lift is engaged on both Lift's Safety Locks at the same height on both Posts. Having multiple Safety Lock positions allows you to lock the Lift at the best height for what you need to do.

CAUTION

Verify that both Safety Locks are engaged at the same height on both Posts. The Lift should not be engaged on Safety Locks of two different heights or the Safety Lock on one Post engaged but the Safety Lock on the other Post not engaged.

Safety Lock positions are created by the Safety Lock Weldments, on the back of each Lift Head.

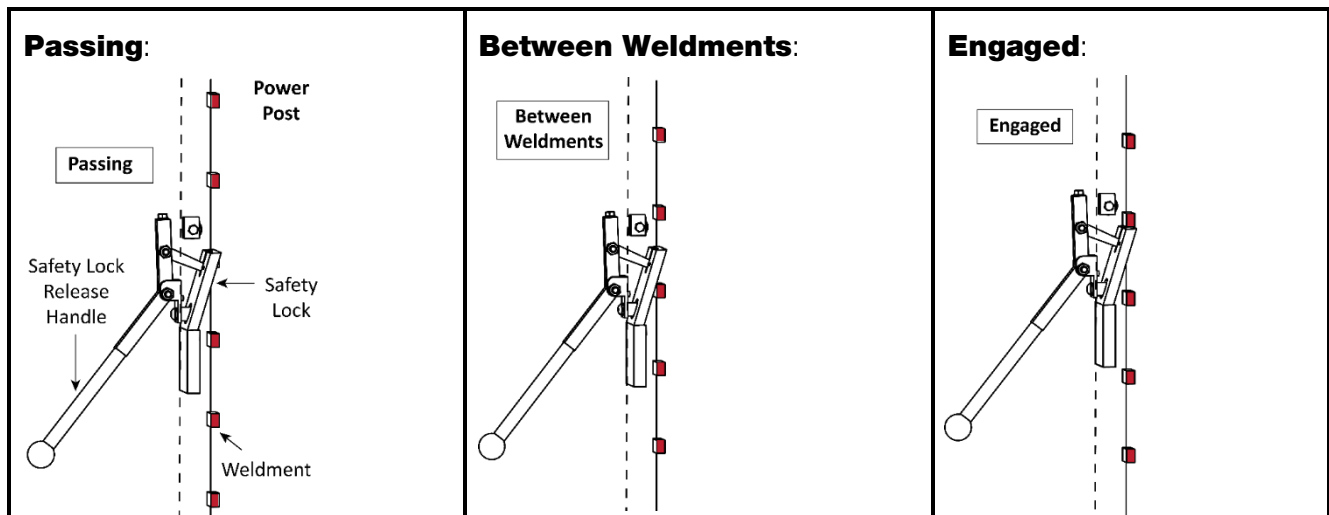





As the Safety Weldments move past the Safety Locks, the Weldments push the Safety Lock and the Safety Lock Release Handle down. When the Weldment is completely past the Safety Locks, the Safety Lock Spring pulls the Lock back into place. This happens each time Safety Locks are passed, so you will generally be hearing multiple clanks as the Lift rises and lowers.

To engage the Lift on a Safety Lock position, press the **Up** Button and wait until the Vehicle reaches the desired height for the work you are going to do, then listen for the clank as the Weldments pass the next Safety Lock position. When you hear the clank, release the **Up** Button, and then hold down the Lowering Handle (on the front of the Power Unit) for a second or two to back the Weldments down onto the just-passed Safety Locks; **do not** hold down the Safety Lock Release Handle.

 **WARNING** Only leave the Lift either fully lowered or engaged on Safety Locks. ***If you leave the Lift raised but not engaged on Safety Locks, the Vehicle is not secure.*** It could fall, possibly damaging the Vehicle, the Lift, and injuring anyone under the Vehicle.

Maintenance

-  **DANGER** Before performing any maintenance on your Lift, verify it is completely disconnected from power. The Lift uses electrical energy; if your organization has Lockout/Tagout policies, make sure to implement them before performing any maintenance. If you come into contact with high voltage, you could be injured or killed.
-  **DANGER** Do not use the Lift if the cables are damaged or extremely worn. If a Vehicle is raised when you notice the damage or extreme wear, very carefully lower the Vehicle to the ground. When the Lift is on the ground, remove it from service, disconnect it from power, and make arrangements for repair.
-  **DANGER** Always wear proper Personal Protective Equipment (PPE) when working with hydraulics. Gloves and Safety Glasses are a minimum requirement. Keep your body away from suspected leaks. Use a clean piece of sheet metal to pass along hoses and fittings to detect leaks. Shut down the equipment if a leak is suspected or
-  **WARNING** Do not operate your Lift if you find maintenance issues; instead, remove it from service and correct the maintenance issues. Technical support and service is available from your dealer, on the Web at [bendpak.com/support](https://www.bendpak.com/support), by email at support@bendpak.com, or by phone at **(800) 253-2363**, option 7 then 4. Online chat is also available at www.bendpak.com click the chat icon. 

Read the Installation and Operation manual and understand how this equipment operates before using, maintaining, or repairing. Routine maintenance and adjustments are the responsibility of the owner/user and are not covered under warranty.

Routine maintenance and adjustments should be carried out on a regular basis as outlined below. *Unless stated otherwise, all maintenance may be performed by the owner/employer and does not require trained lift service personnel.* Replace worn, damaged or broken parts with original BendPak or BendPak approved parts or with parts that meet or exceed the original specifications.

Maintenance and Interval Recommendations:

This lift's service life is dependent on the level and frequency of care and maintenance you provide. By simply following a few guidelines, you can increase the life of your lift by many years. The following care and maintenance procedures not only help to foster that, but also aid by ensuring safe operation and early detection of problems.

Tools required:

- Open End Wrench Set
- Screwdrivers (Phillips and slotted)
- Hydraulic Fluid (same type and weight as the current fluid in use.)
- Clean shop towels
- Hex Key Set
- Lubricants
 - White Lithium Multi-Purpose Lubricant
 - Red Lithium Grease
 - ALMASOL Wire Rope Lubricant or 90W Gear Oil

The following maintenance and interval recommendations are based on typical workday use and operation.

Daily Maintenance

1. Keep the Lift and work area clean, to promote both safety and better problem visibility.
2. Visually inspect that the Safety Locks are in good operating condition. Do not use your Lift if the Safety Locks are damaged or excessively worn. Check for wear and adjust the tension on the equalizing cables.
3. Check the Hydraulic Fluid Level in the Reservoir. Add fluid, if necessary.
4. Check for hydraulic fluid leaks on hoses, fittings, and cylinders. Inspect for damage. Hose covers that are cut, cracked, blistered, show signs of abrasion, kinking or flattened are to be replaced. Cylinder ports that are cracked, show signs of leaking or other damage.
5. Start the hydraulic system and pass a clean piece of sheet metal near the hydraulic hoses, fittings, and cylinders. Hydraulic fluid on the metal indicates a leak. Shut down the system and tagout the Lift to prevent use until repaired.
6. Verify the cylinder clamp is in place and tight on both hydraulic cylinders just above the Lift head.

Monthly Maintenance

1. Remove, clean, and apply new Red Lithium grease to all Cable Sheave Pins as outlined in the Lubrication Procedure.
2. Inspect the condition of all Equalizing Cables and mechanisms. Run a shop towel over the Cable surface while watching for snags. Replace as required.
3. Inspect all hydraulic hoses, fittings, and cylinders for damage and leaks.
4. Apply 90-WT gear oil or ALMASOL® Wire Rope Lubricant to both Equalizing Cables.
5. Apply White Spray Lithium MP grease to the four inside contact corners of both Posts.
6. Apply White Spray Lithium MP grease to all Lift Arm Pivot Points.

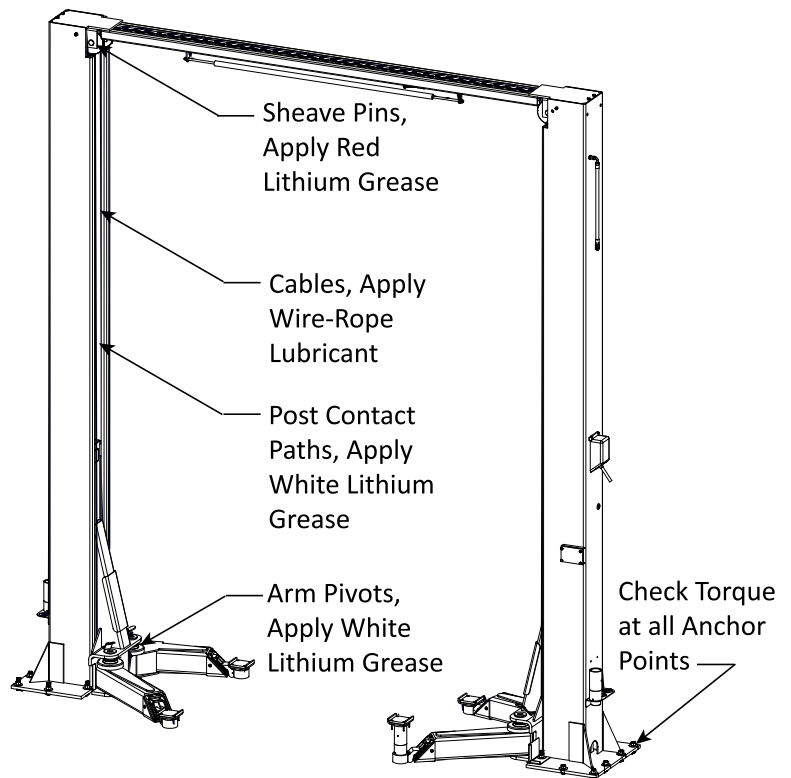

7. Inspect all Lift Arm Pins and locking mechanisms for damage and wear. Replace as required.
8. Verify all fasteners are torqued to specifications.
9. Verify all Warning labels are in good condition and legible.

Every Two Months

Verify all anchor bolts are secure and torque to 85-95 ft.-lbs.

Every three to five years or as required

1. Carefully check the Equalizing Cables for signs of damage or extreme wear. See **Wire Rope Inspection and Maintenance** for additional information.
2. If the Lift becomes inoperative in a raised position, refer to the **Troubleshooting** section.

Lubrication Procedure

To Lubricate the Upper Corner Sheaves

1. Raise the Lift Head to rest on at least the first Safety Lock.
2. Remove the Polyethylene Cover from the Lift Head then loosen the Cable Nut to relax the cable.
3. Lubricate the Upper Corner Sheave.
 - a. Remove Screw securing pin at the upper sheave.
 - b. Remove the Pin from the Sheave.
 - c. Apply Red Lithium Grease to the Pin.
 - d. Reinstall the Sheave Pin through the Sheave then insert and tighten screw.
 - e. Tighten the Cable Nut.See Leveling Section to readjust Lift Arms.

After relaxing respective cables, perform these two steps.

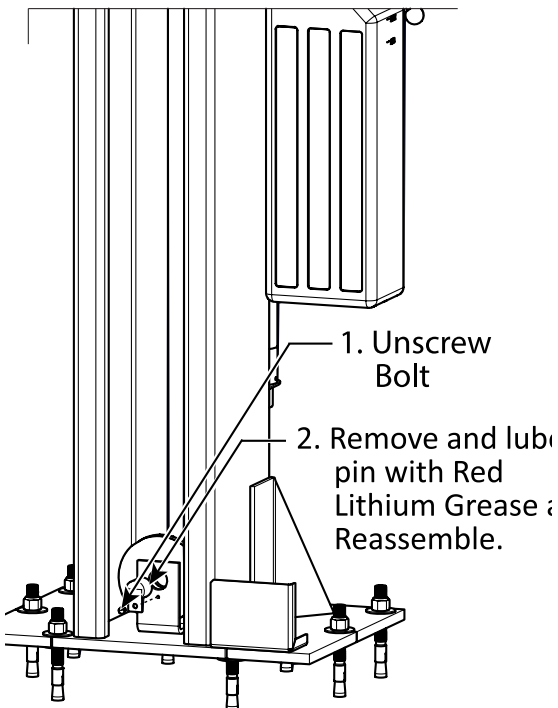

- a. Remove Screw
- b. Remove Pin
- c. Apply Grease
- d. Put in Sheave
- e. Tighten Cable

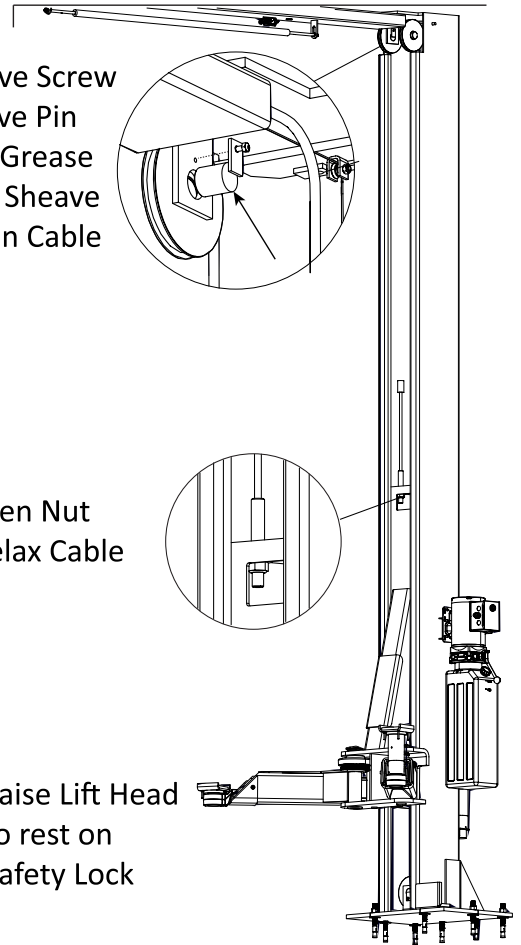

To Lubricate the Lower Sheaves

1. Relax respective cables, as outlined above.
2. Unscrew Sheave Pin Bolt.
3. Remove Sheave Pin.
4. Apply Red Lithium Grease to Sheave Pin.
5. Reassemble and tighten.

12APX Wire Rope Inspection and Maintenance

The 12APX Equalizing Cables should be inspected regularly:

- Cables should be replaced when there are visible signs of damage or extreme wear. **Do not use the Lift if it has damaged or worn cables.**
- Lifting cables should be always maintained in a well-lubricated condition.

Wire rope is fully protected when each wire strand is lubricated both internally and externally. Excessive wear shortens the life of wire rope. Use a wire-rope lubricant that penetrates to the core of the rope and provides long-term lubrication between each individual strand, such as 90-WT gear oil or ALMASOL® Wire Rope Lubricant.

To make sure that the inner layers of the rope remain well lubricated, lubrication should be carried out at intervals not exceeding three months during operation.

- All sheaves and guide rollers in contact with the moving rope should be given regular visual checks for surface wear and lubricated to make sure they run freely. This operation should be carried out at appropriate intervals generally not exceeding three months during operation.

For all sheave axles, use standard wheel bearing grease. For all sheaves and/or guide rollers, use 90-WT gear oil or a similar heavy lubricant, applied by any method including pump/spray dispensing, brush, hand, or swabbing.

- How often should the Cables be inspected?

Lifting cables should be visually inspected at least once each day when in use, as suggested by American Petroleum Institute's Recommended Practice 54 guidelines. Any lifting cables that have met the criteria for removal must be immediately replaced.

- When should you replace lifting cables due to broken wires?

Lifting cables should be removed from service when you see six randomly distributed broken wires within any one lay length, or three broken wires in one strand within one lay length.

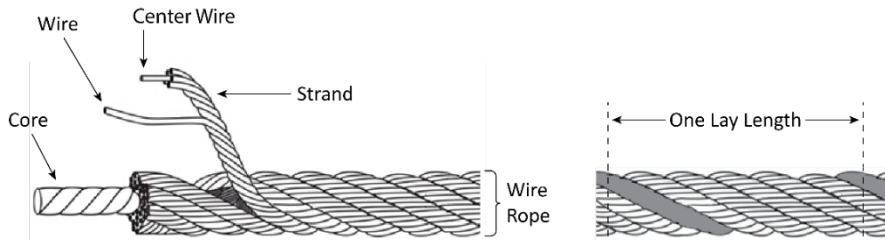



- Are there other reasons to replace your lifting cables?

Yes. Corrosion that pits the wires and/or connectors, evidence of kinking, crushing, cutting, bird-caging, or a popped core, wear that exceeds 10% of a wire's original diameter, or heat damage.

- Finding broken wires:

- a. Relax the wire rope to a stationary position and move the pick-up points off the sheaves. Clean the surface of the rope with a cloth — a wire brush, if necessary — so you can see any breaks.
- b. Flex the rope to expose any broken wires hidden in the valleys between the strands.
- c. Visually check for any broken wires. One way to check for crown breaks is to run a cloth along the rope to check for possible snags.
- d. With an awl, probe between wires and strands and lift any wires that appear loose. Evidence of internal broken wires may require a more extensive rope examination.

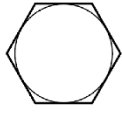
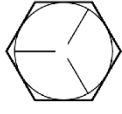
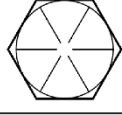
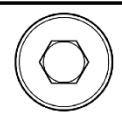
Torque Chart

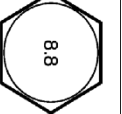
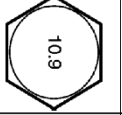
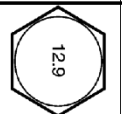
FASTENER TORQUE CHART													
Bolt Size (SAE)	Bolt Size (Metric)	Tightening Torque			Tightening Torque			Tightening Torque			Tightening Torque		
		Lubricated (ft.-lbs)	Zinc Plated (ft.-lbs)	Plain & Dry (ft.-lbs)	Lubricated (ft.-lbs)	Zinc Plated (ft.-lbs)	Plain & Dry (ft.-lbs)	Lubricated (ft.-lbs)	Zinc Plated (ft.-lbs)	Plain & Dry (ft.-lbs)	Lubricated (ft.-lbs)	Zinc Plated (ft.-lbs)	Plain & Dry (ft.-lbs)
	Bolt Grade (SAE)		SAE Grade 0-1-2		SAE Grade 5		SAE Grade 8		Socket Head Cap Screw	SAE Grade			
	Bolt Class (Metric)		Metric Class 4.6		Metric Class 8.8		Metric Class 10.9		Metric Class 12.9				
1/4-20	M6 x1.0	2.3	2.6	3.0	5.8	6.6	7.7	8.3	9.4	11.1	9.7	11.0	
5/16-18	M8 x 1.25	3.8	4.3	5.0	9.7	11.0	13.0	13.9	15.8	18.5	16.3	18.4	
3/8-16	M10 x 1.50	10.8	12.3	14.4	27.9	31.6	37.2	39.9	45.2	53.2	46.7	52.9	
7/16-14	N/A	24.0	27	30.0	35.0	42	50.0	55.0	59	70.0	61.0	68	
1/2-13	M12 x 1.75	18.9	21.4	25.2	48.7	55.1	64.9	69.6	78.9	92.8	81.4	92.2	
9/16-12	M14 x 2.00	30.2	34.2	40.2	77.8	88.1	103.7	111.3	126.1	148.4	130.0	147.4	
5/8-11	M16 x 2.00	47	53	62	121	137	161	173	196	230	202	229	
3/4-10	M18 x 2.50	65	73	86	167	189	222	239	270	318	279	316	
7/8-9	M22 x 2.50	136	155	182	320	365	430	460	515	600	510	575	

WARNING! Prior to installation, inspect all accompanying manuals, parts lists and catalogs to ensure you have all the necessary parts. Identify all fasteners and their proper torque settings as illustrated on this chart. Proper torquing practices cannot be over emphasized. Torque values are provided as a convenient method of achieving correct pre-loading of highly stressed fasteners. If the fasteners are not properly plated, the fastener threads are not clean and free of deformation, or are not properly lubricated, the correct fastener pre-load will not be achieved even though the given torque value is reached. For this reason, it is critical that all fasteners be inspected for proper plating, thread form and correctly lubricated prior to torquing. Failure to verify a fastener's serviceability or to correctly lubricate the fastener prior to assembly and torquing will result in the fastener not being properly pre-loaded and subsequent failure of the fastener may occur. The torque values can only be achieved if the nut (or tapped hole) has a proof load greater than or equal to the bolt's minimum ultimate tensile strength. Clamp loads estimated as 75% of proof load for specified bolts. Torque values are listed in foot-pounds. Torque wrenches should be calibrated on an annual basis. Never use an impact driver on a torque multiplier.

Troubleshooting

This section describes how to troubleshoot your Lift.

NOTICE If your Lift is not functioning correctly, you must take it out of service until it is repaired.

Important: Replace worn, damaged or broken parts with original BendPak or BendPak approved parts or with parts that meet or exceed the original manufacturer specifications.

⚠ DANGER Before performing maintenance on your Lift, verify it is disconnected from power. The Lift uses electrical energy; if your organization has Lockout/Tagout policies, implement them before performing any maintenance. If you come into contact with high voltage, you could be injured or killed.

⚠ DANGER Always wear proper Personal Protective Equipment (PPE) when working with hydraulics. Gloves and Safety Glasses are a minimum requirement. Keep your body away from suspected leaks. Use a clean piece of sheet metal to pass along hoses and fittings to detect leaks. Shut down the equipment if a leak is suspected or detected.

⚠ DANGER Prior to removing or tightening **any** hydraulic fitting or hose, verify the Lift Heads are secured on a Safety Lock or resting on the ground. Push in the Down Lever for an extra five to ten seconds after the Lift Heads have stopped moving to ensure that pressure is relieved from the hydraulic system.

Issue	Action to Take
Lift becomes inoperative in a raised position.	Verify there is sufficient Hydraulic Fluid in the reservoir. Verify the Lift Carriages are above and clear of the Safety Locks. Verify none of the Hydraulic Hoses are pinched or leaking. Verify the Power Unit is being supplied power. Make sure the Lift is not overloaded. Make sure the load on the Lift is balanced. Contact bendpak.com/support . or by phone at (800) 253-2363 , select option 7, then 4.
Arms move erratically or squeak when in use.	Move the Lift Arms up and down a few times to flush any residual air from the Hydraulic System.
Off Side Lift Head will not lower.	See broken Safety Cable procedure below.
Lift does not stay up.	Make sure to leave the Lift engaged on its Safety Locks. Check for Hydraulic Fluid leaks.
Vehicle on Lift is not level.	Make sure Lift is engaged on Safety Locks at the same height. Make sure the Safety Locks in both Posts are engaged. If either condition is not met, carefully lower the Vehicle back down to the ground and raise it again.
Motor is not running.	Check connection to power source; verify it is plugged in and the voltage is correct. Verify circuit breaker is not tripped. Check the wiring diagram on the Power Unit.
Hydraulic Fluid is dirty.	Replace the dirty Hydraulic Fluid with clean, approved ATF fluids, such as Dexron III, Dexron VI, Mercon V, Mercon LV, or comparable.
Lift makes odd noises.	Lubricate hinge points using white lithium grease.

Technical support and service is available from your dealer, on the Web at bendpak.com/support, by email at support@bendpak.com, or by phone at **(800) 253-2363**, select option 7, then 4.

Broken Safety Cable Procedure

If the Safety Cable breaks, the Power Side Lift head will lower but the Off Side Lift Head will not.

To release the Off Side Safety Lock:

1. Raise the Lift Heads off the Safety Locks.
2. Have an assistant reach through the access hole with a stiff wire or pick to pull the Safety Block away from the Lift Head. See figure below.
3. Hold in Safety Release on the Power Side Lift Post while holding the lower handle to Power Unit.
4. When the Lift heads are on the ground and the Lift is in a safe condition, remove power from the Lift and replace the Safety Cable.

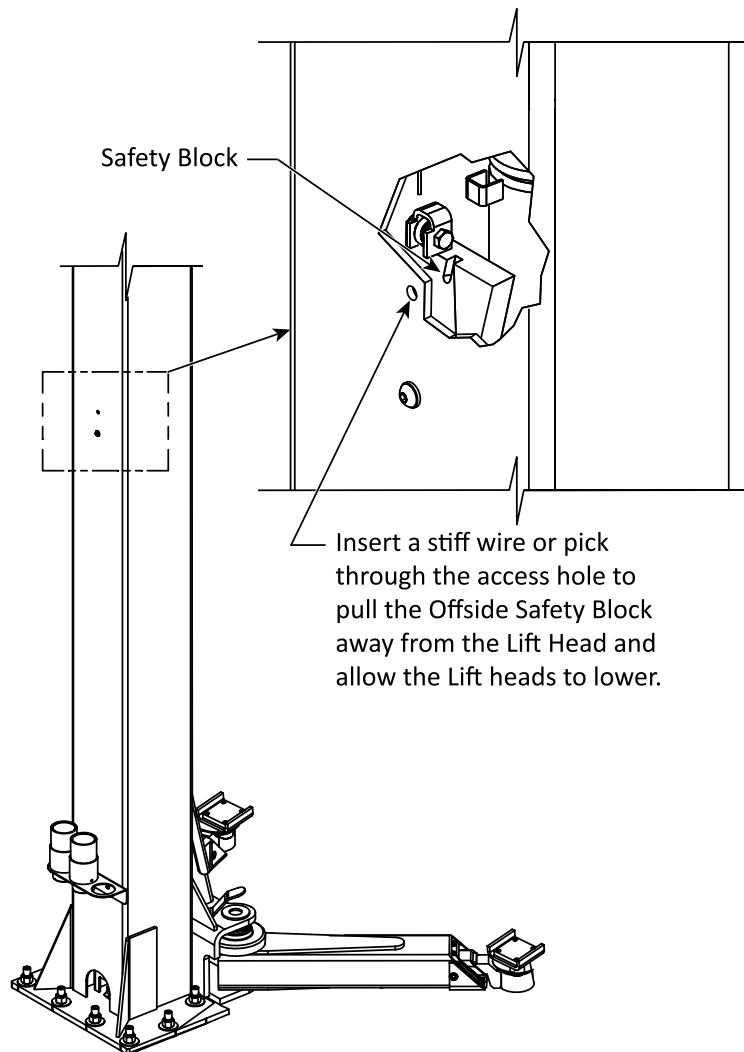

Reference only – do not scale.

Troubleshooting Lift Arm Lock Disengagement

⚠ WARNING Avoid excessive Shim heights! A new concrete cutout and steel reinforced pour are recommended to correct out of level conditions in excess of 3°.

Some floors with excessive out of level conditions may require Shim heights that reach or exceed 0.5 in. (12.7 mm). When the Shim Height reaches this level, the Lift Arm Lock Pins may not function to disengage the Lift Arms when completely lowered. To correct this condition, the Arm Lock Pins include an M12 x 1.75 internal thread, approximately 12 mm deep. A mating M12 Hex Head Bolt with Lock Washers, or a backing nut (not supplied) may be used to extend the contact point of the Arm Lock Pins. Adjust the Bolt head position to disengage the Lock as required. Refer to the figure below.

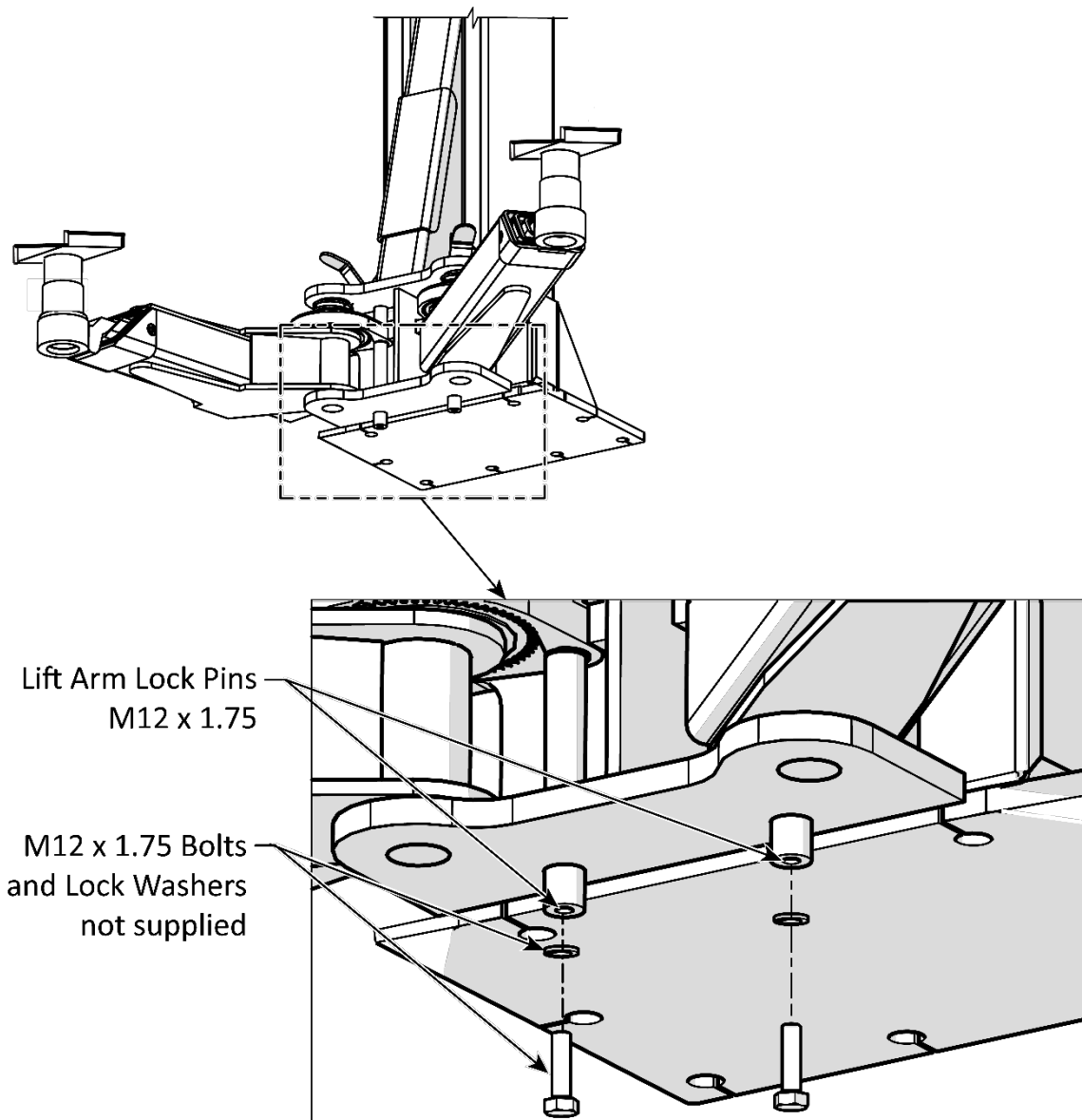

Disposing of Used Hydraulic Fluid

Used Hydraulic Fluid cannot be disposed of by dropping it into the trash or dumping into the street. Hydraulic Fluid has toxic ingredients that are harmful to the environment. Either recycle the Hydraulic Fluid or drop it off at a hazardous waste collection facility. Dirty or contaminated fluid must be treated as hazardous waste. Rags and/or granular absorbents that have soaked up Hydraulic Fluid should be treated like hazardous waste and be disposed of at a hazardous waste collection facility.

To find an appropriate facility:

- Local automotive parts stores, auto care facilities, or automobile dealerships may accept fluid for recycling or, in some cases, for disposal. Contact them for more information.
- Cities, counties, and states often support both recycling facilities and hazardous waste collection facilities. Contact them to see if and where they have these programs.

If you are unable to find an appropriate facility, the website [earth911.com](https://www.earth911.com) has resources that may be of help.

Lift Disposal - End of Service Life

Once your Lift has reached the end of its service life it must be disposed of properly. Metal recyclers will be able to advise on methods and costs to remove the Lift and will *reuse* the materials, diverting them from landfills. The best option is to contact a metal recycling center and discuss the size and weight of the Lift to determine if the facility can deconstruct and recover the usable components and metals.

The Hydraulic Cylinders, Hoses, Fittings, and the Power Unit itself must be disposed of in accordance with current national, state, and local regulations governing the use and disposal of hazardous materials. These components and any used Hydraulic Fluid **must not** be disposed of by dropping it into the trash or dumping it into the street. The Hydraulic Fluid contains toxic ingredients that are harmful to the environment.

These components and the Hydraulic Fluid are required to be recycled or must be delivered to a hazardous waste collection facility.

If you have large amounts of Hydraulic Fluid, consider contacting a commercial waste disposal company. In all cases, the best approach is to find an appropriate facility and contact them — in advance — to ask them: what kinds of fluids and materials they accept, what kind of containers it must be in, what hours they are open, their location, and any other information specific to their facility.

If you are unable to find an appropriate facility, the website [earth911.com](https://www.earth911.com) has resources that may be of help.

Wiring Diagrams

This section includes wiring information for the Overhead Limit Switch.

⚠ DANGER All wiring **must** be performed by a licensed Electrician in accordance with all local and national electrical codes. Make sure that main electrical power has been disconnected from the Lift and cannot be re-energized until all procedures are complete. If your organization has Lockout/ Tagout policies, make sure to implement them after connecting the Lift to power.

IMPORTANT! The Power Unit Consumes 23 Amps at 208-230 VAC, 50/60 Hz., Single Phase. The electrical circuit should be protected by a 30 Amp Circuit Breaker or time-delay fuse.

To Connect the Limit Switch (Single Phase):

1. Remove and retain the three Cover Screws.
2. Remove and retain the Switch Cover.
3. For Single Phase installations, feed the SJO cord through the Strain Relief in the Switch Cover.
4. Strip the insulation off two of the conductors and connect to the Normally Closed Terminals. One wire to terminal 21 and the other to terminal 22.
5. Inspect to verify no stray wire strands are bridging across the terminals. If strands are bridging, correct before proceeding.
6. Replace the Switch Cover and secure with the three screws removed in step 1.

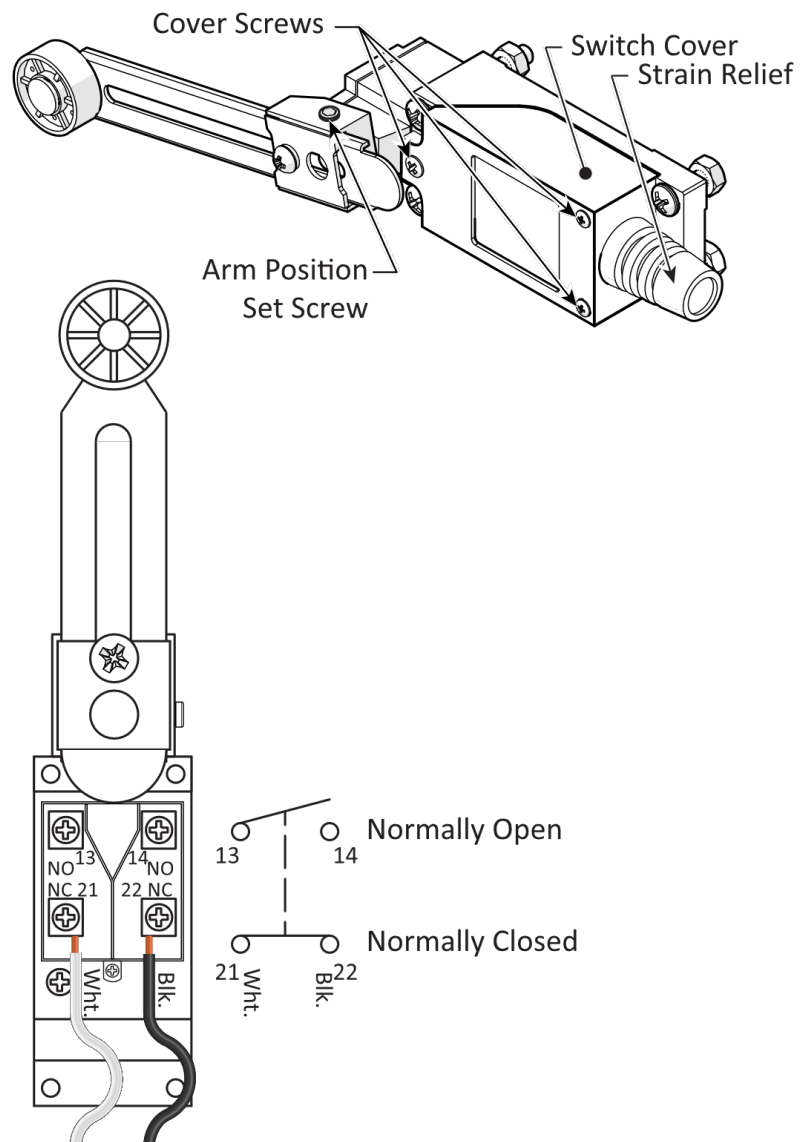

Power Unit Wiring

IMPORTANT! The Power Disconnect and Thermal Disconnect are not supplied with this Lift. These components must be supplied and installed by a licensed Electrician in accordance with the National Electrical Code (NEC). The Thermal Disconnect while not an NEC requirement may be required by local electrical code.

Single-Phase

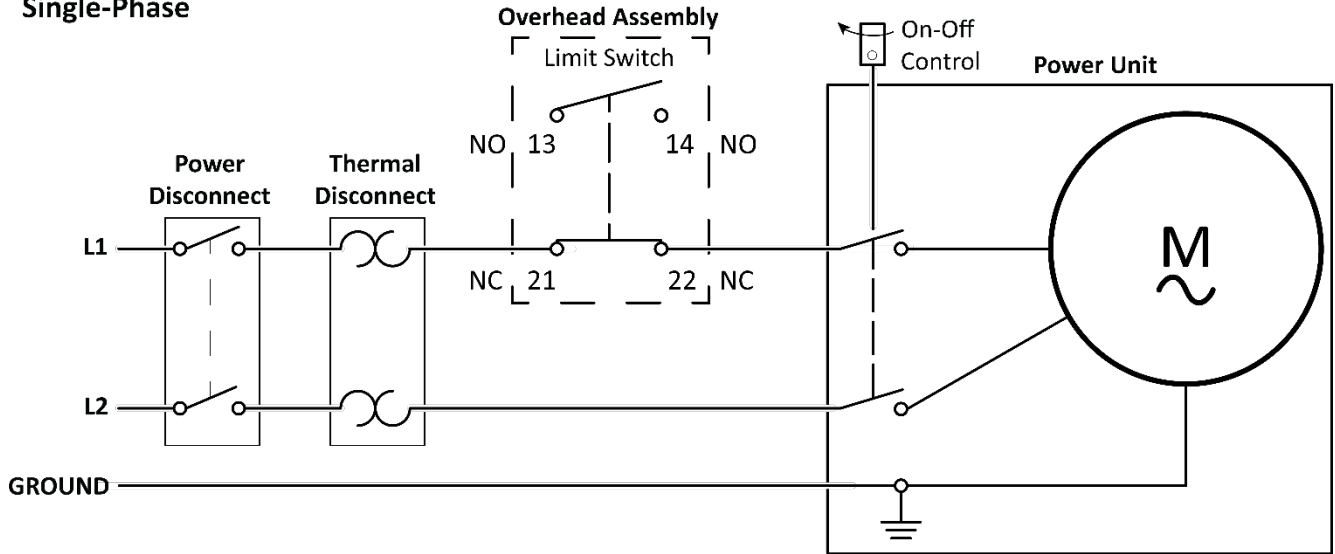

Power Unit 5585685

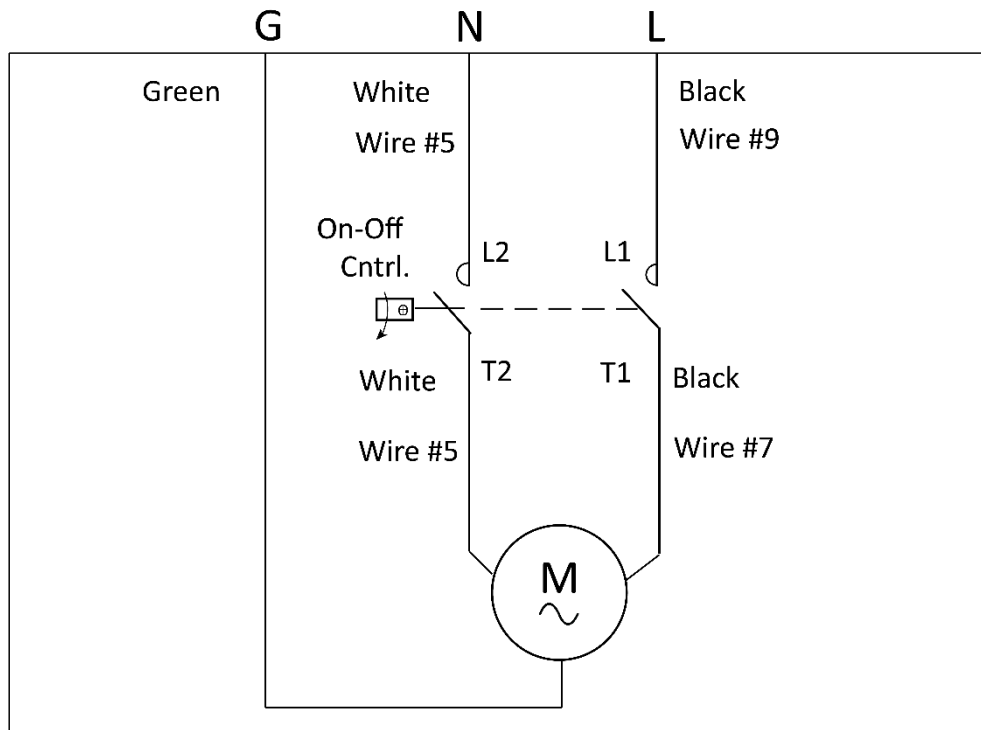

Power Unit Motor
 208-230V, 1PH, 50/60 HZ,
 2880/3450rpm, 5HP, CSA approved

Three-Phase Limit Switches Installation

This section includes assembly and wiring information for the Three-Phase Overhead Limit Switches. Requires the **AP Clear Floor 3ph Micro Switch Kit part number 5216263**.

⚠ DANGER All wiring **must** be performed by a licensed Electrician in accordance with all local and national electrical codes. Make sure that main electrical power has been disconnected from the Lift and cannot be re-energized until all procedures are complete.

To Wire the Limit Switches (Three Phase):

1. Remove and retain the three Cover Screws on both Limit Switches.
2. Remove and retain the Limit Switch Covers.
3. Strip Back the Jacket of the 14/4 Cable about 5 inches (127 mm) to expose the 4 conductors.
4. Push the black and white wires through the strain relief on one switch cover and the red and brown through the Strain Relief on the remaining cover.
5. Strip the insulation back on all four conductors about 1/2 in. (13 mm) and connect one wire to each side of the *Normally Closed Terminals* on each switch. Refer to the figure below. Inspect to verify no stray or broken wire strands are bridging across the terminals.
6. Replace the Switch Covers and secure with the three screws removed in step 1.

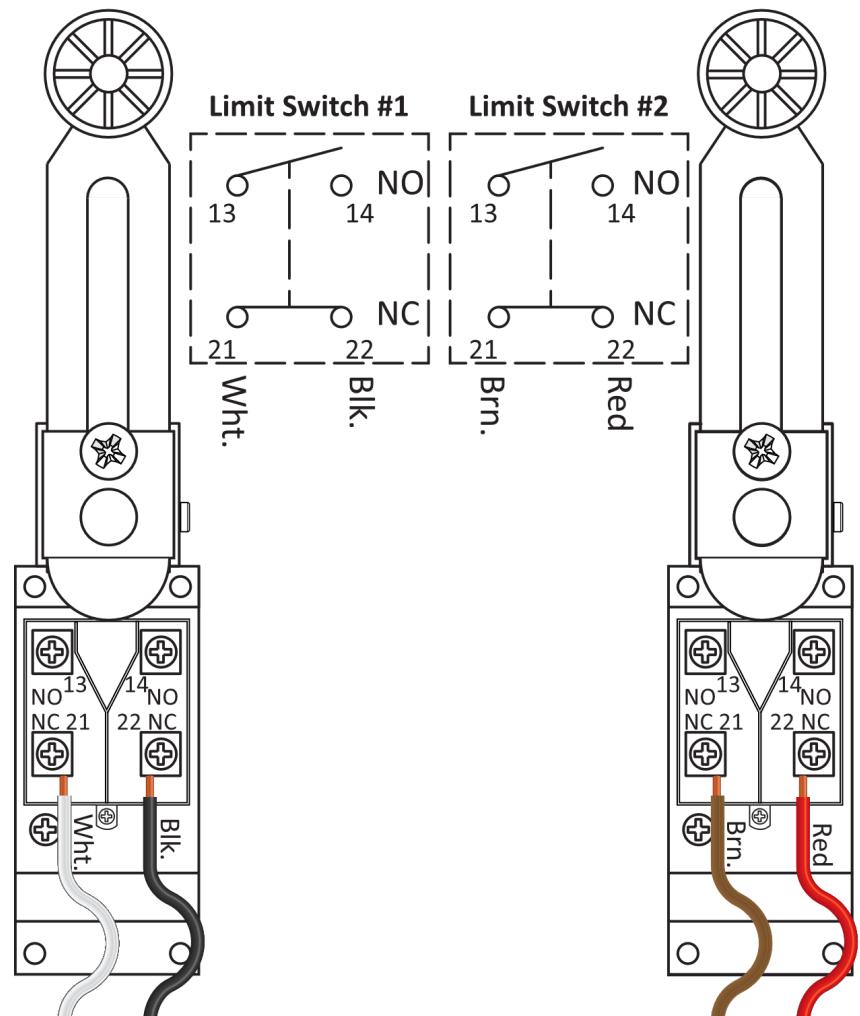

7. Secure the switches to the bracket on the Overhead assembly. Refer to the figures below Wiring removed for clarity.
8. Attach the 3-Phase Limit Switches to the Lift's Overhead Assembly using the fasteners described below.

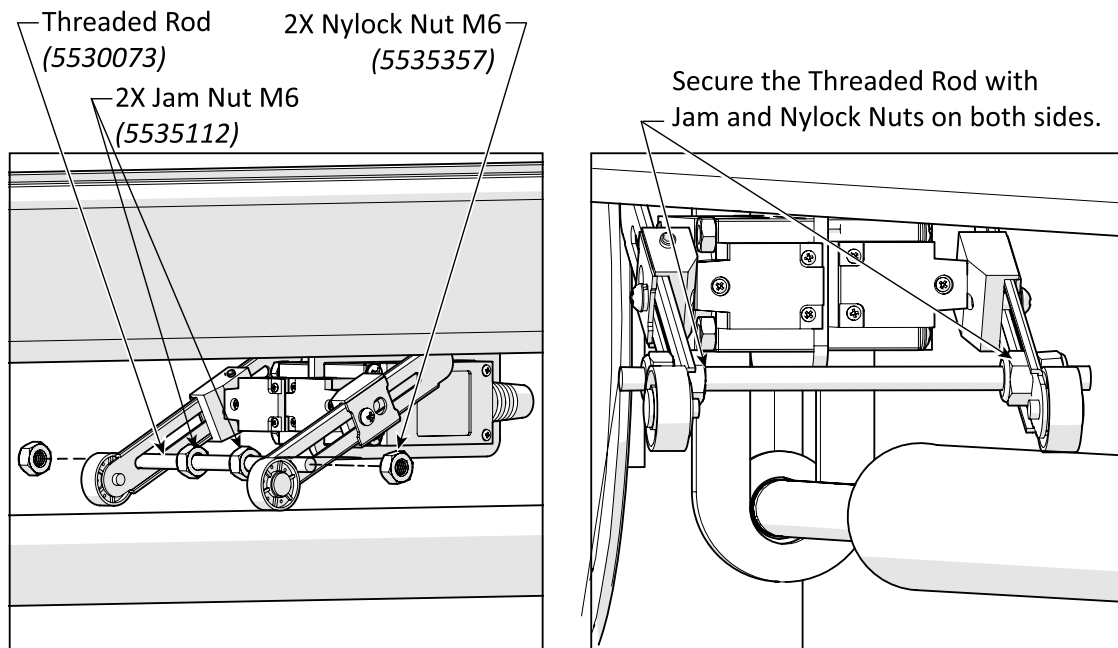
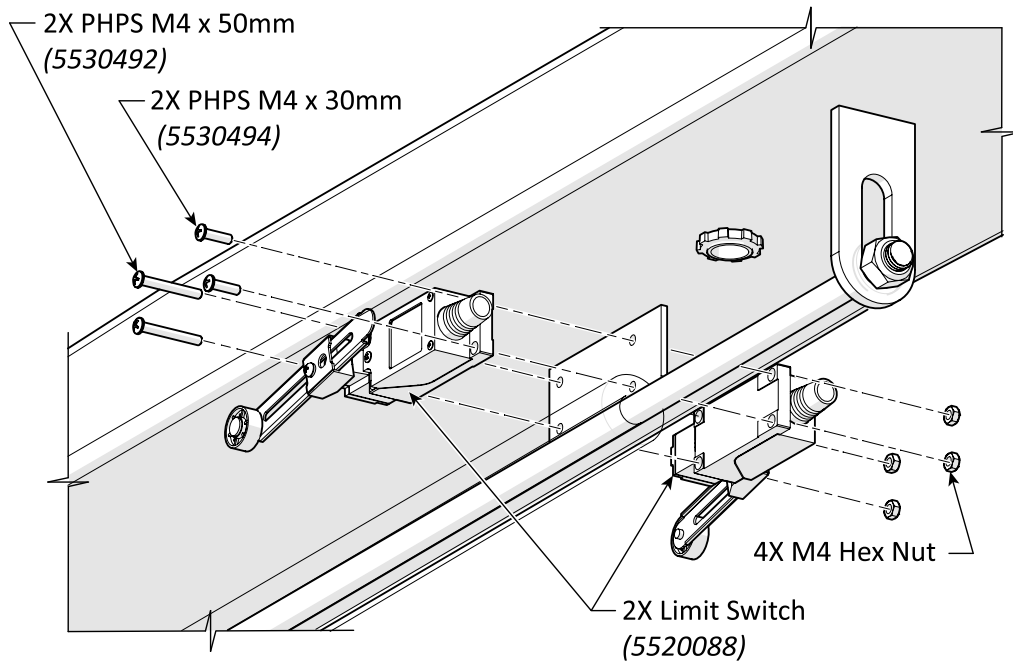

Components removed for clarity.

9. Assemble the Threaded Rod Spacer between the Actuator Arms and secure with the Jam Nuts as shown above.
10. Loosen **BOTH** Arm Rotation Set Screws and allow the Actuator Arm to rest on the Limit Switch Stop Bar. Adjust the length of the Actuator Arm, if required.

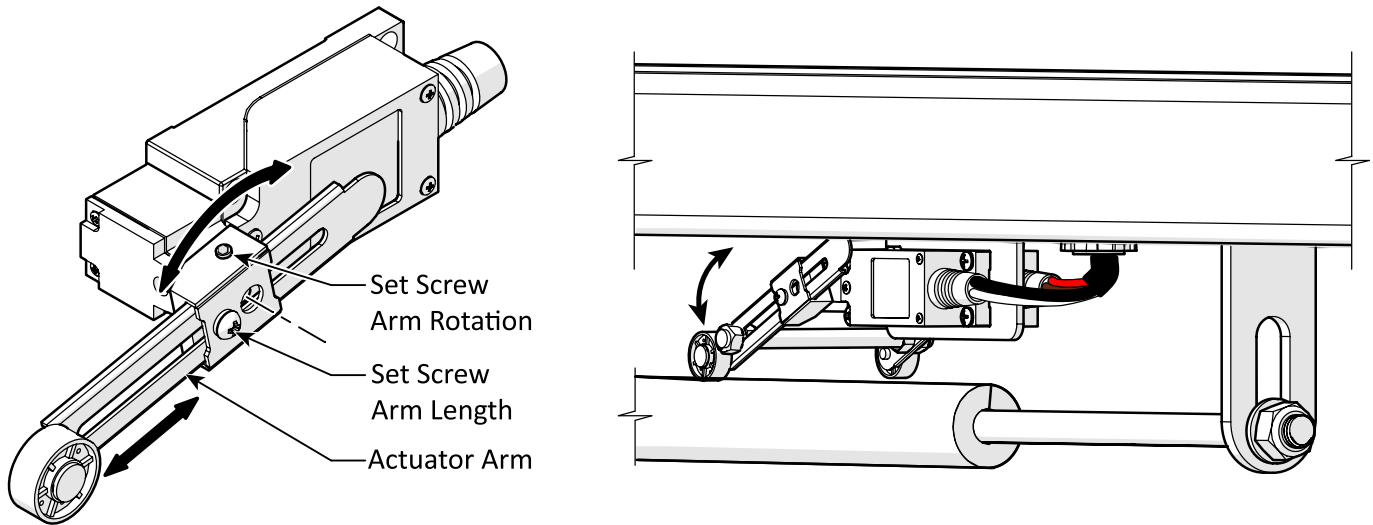

11. Tighten the Arm Rotation Set Screws on **BOTH** Limit Switches.
12. Push up on the Limit Switch Stop Bar. The Limit Switches should rise and fall with the Stop Bar.
13. Feed the 14-4 Cable up through the Cable Connector and secure using the connector's two screws.
14. Route the 14-4 Cable through the Cable Clips across the Overhead and down the Power Side Lift Post.
15. Bend the Cable Clips to secure the cable flat against the Overhead and the Lift Post.
16. Verify the Cable is held firmly in the Cable Clips and has little to no slack inside the Lift Post. Excessive slack could interfere with moving components inside the Lift Post leading to Cable damage and malfunction.
17. Feed the 14-4 Cable out through the grommets below the Safety Lock Release.

Three-Phase Power Unit Wiring

IMPORTANT! The Power Disconnect and Thermal Disconnect are not supplied with this Lift. These components must be supplied and installed by a licensed Electrician in accordance with the National Electrical Code (NEC). The Thermal Disconnect while not an NEC requirement may be required by local electrical code.

⚠ DANGER All wiring **must** be performed by a licensed Electrician in accordance with all local and national electrical codes. Make sure that main electrical power has been disconnected from the Lift and cannot be re-energized until all procedures are complete.

Three-Phase Block Diagram

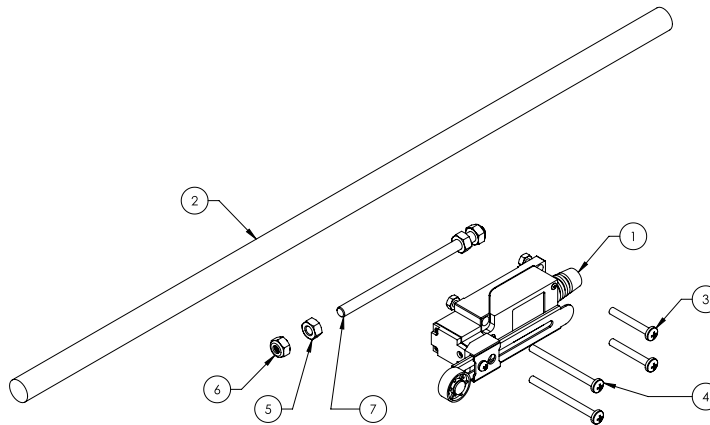
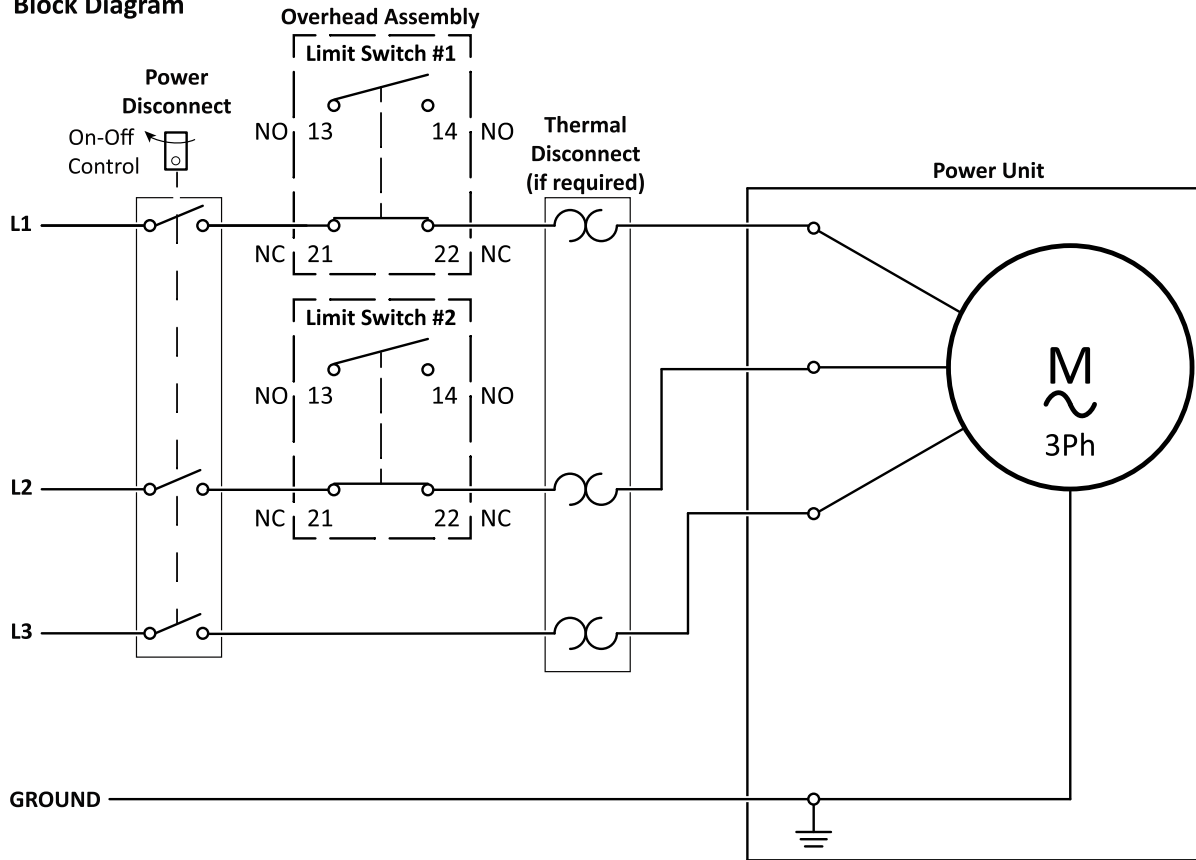

NOTE: UNLESS OTHERWISE SPECIFIED...
 1. REFER TO MODEL FOR ADDITIONAL INFORMATION
 2. SEE SHIPPING INSTRUCTIONS FOR FINAL PACKAGING

ITEM NO.	PART NUMBER	DESCRIPTION	QTY	REV
1	5520088	ROCKER LIMIT SWITCH, 25A	1	--
2	5520116	CABLE, AWG 14-4, SOOW	5000mm	--
3	5530494	PHPS M4 x 0.7 x 30 FT	2	--
4	5530492	PHPS M4 x 0.7 x 50 FT	2	--
5	5535112	NUT M6 x 1.0	2	--
6	5535357	NUT M6 x 1.0 NL, CL10.9	2	--
7	5530073	THREADED ROD M6 x 1.0 x 110 FT, CL 4.8	1	--

DO NOT SCALE DRAWING	NAME	DATE	 3040 AGOURA RD. AGOURA HILLS, CA 91301
	DRAWN: TM	03/27/2024	
DIMENSIONS ARE IN MM	CHECKED		TITLE: AP CLEARFLOOR 3ph MICROSWITCH KIT
 WHERE USED 3 PHASE LIFTS	THIRD ANGLE PROJECTION PROPRIETARY AND CONFIDENTIAL THIS INFORMATION IS UNCLASSIFIED EXCEPT WHERE SHOWN OTHERWISE FOR PROTECTION CONTACT: BENDPAK INC.	SEE DWG. NO. A 5216263	REV A
		SCALE: 1:2	SHEET 1 OF 1

PN 5905109 Label Kit

F

NOTICE	CAUTION	CAUTION
Read operating and safety manuals before using lift.	Lift to be used by trained operator only.	Authorized personnel only in lift area.
NOTICE	CAUTION	CAUTION
Proper maintenance and inspection is necessary for safe operation.	Use vehicle manufacturer's lift points.	Always use safety stands when removing or installing heavy components.
NOTICE	CAUTION	CAUTION
Do not operate a damaged lift.	Use height extenders when necessary to ensure good contact.	Auxiliary adapters may reduce load capacity.

WARNING	WARNING
Clear area if vehicle is in danger of falling.	Position vehicle with center of gravity midway between adapters.
WARNING	WARNING
Remain clear of lift when raising or lowering vehicle.	Avoid excessive rocking of vehicle while on lift.
WARNING	WARNING
Do not override self-closing lift controls.	Keep feet clear of lift while lowering.

J

TO RAISE LIFT:

1. Press and hold **UP** button.
2. When lift is just **PAST** desired height, release **UP** button.
3. Hold down Lowering Handle. **DO NOT** hold down Safety Lock Release Handle. Lift engages on safety locks.
4. Release Lowering Handle.

TO LOWER LIFT:

1. Press and hold **UP** button for two to three seconds, moving lift off safety locks.
2. Hold down Safety Lock Release Handle **and** Lowering Handle.
3. When lift is fully lowered, release both handles.

PN 5905414

PN 5905414

H

NOTICE

If attachments, accessories, or configuration modifying components used on this lift are located in the load path and affect operation of the lift, affect the lift electrical listing, or affect intended vehicle accommodation; and if they are not certified for use on this lift, then the certification of this lift shall become null and void. Contact the participant for information pertaining to certified attachments, accessories, or configuration modifying components.

www.autolift.org ©2011 by ALI, Inc. ALI / WLSIA01

PN 5905377

K

CALIFORNIA PROPOSITION 65

⚠ **WARNING** ⚠

WARNING! This product can expose you to chemicals including styrene and vinyl chloride which are on the list of over 900 chemicals identified by the State of California to cause cancer, birth defects or reproductive harm. ALWAYS use this product in accordance with the manufacturer's instructions.

For more information, go to www.p65warnings.ca.gov.

PN 5905775

PN 5905775

I

L



PN 5906044

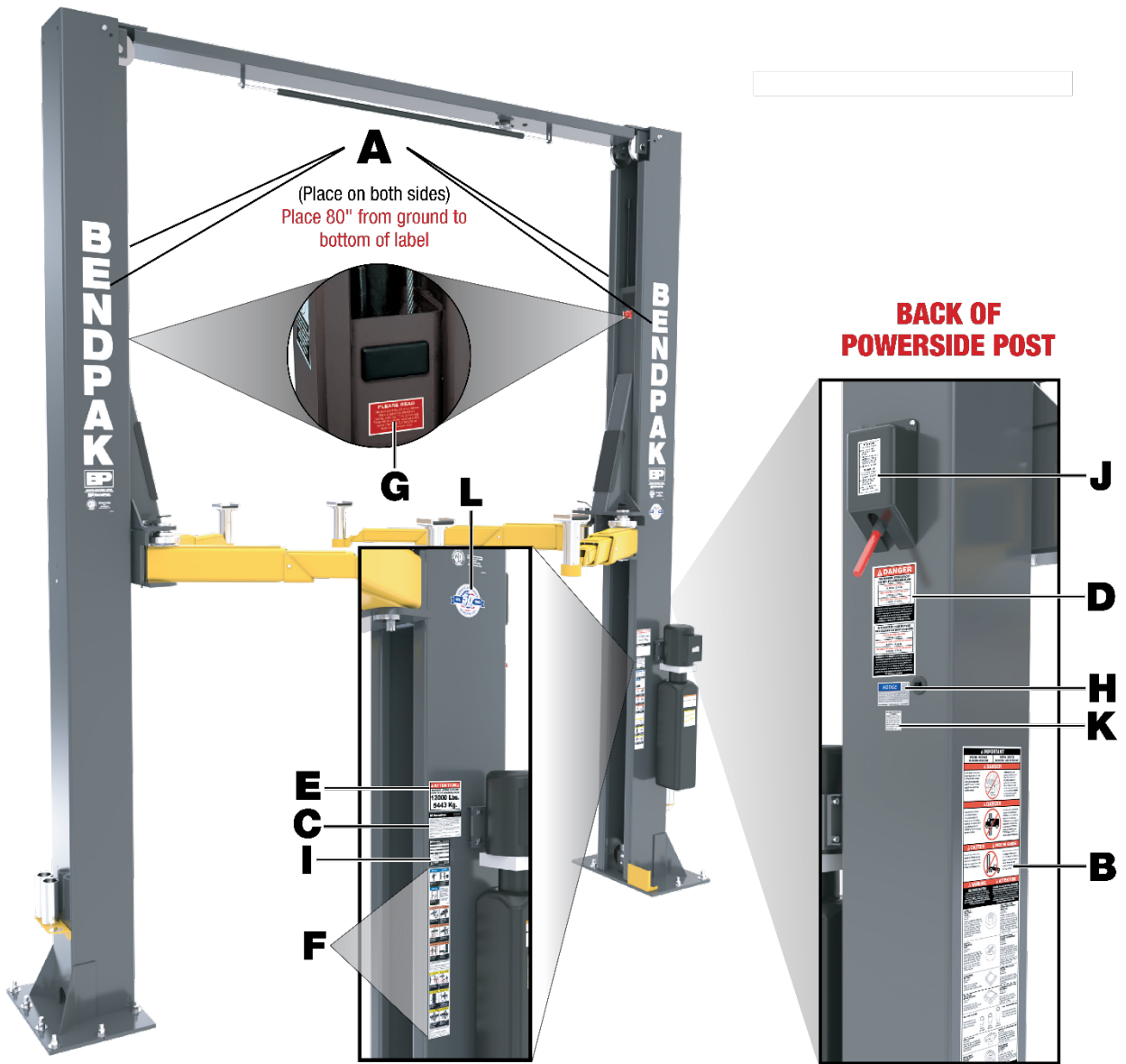

POWERSIDE POST

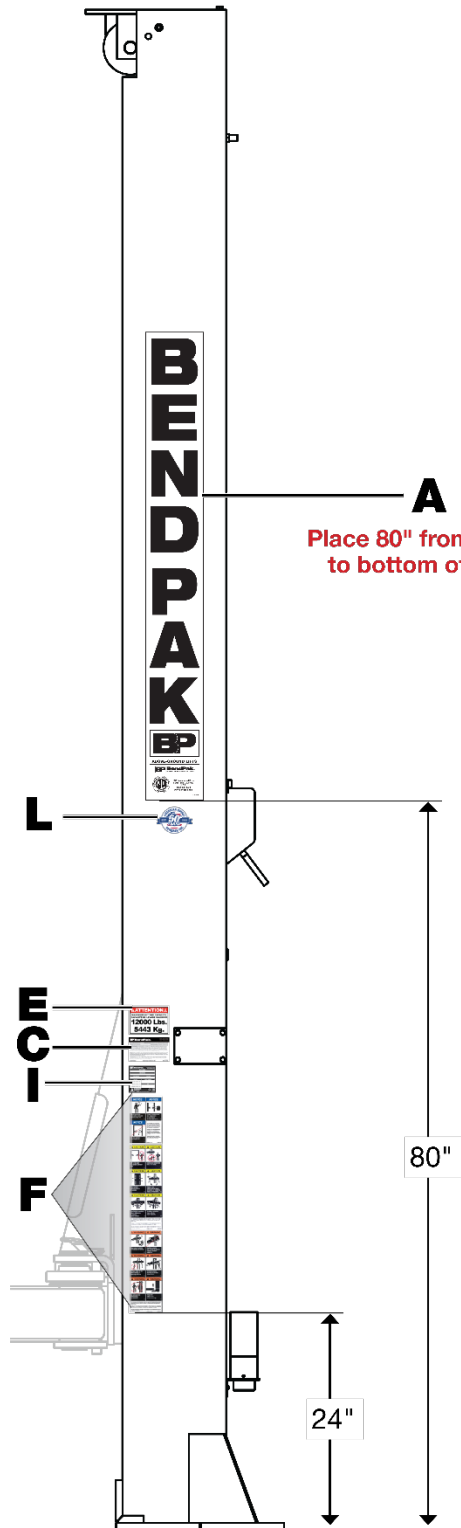

ADJACENT TO PU POWERSIDE POST

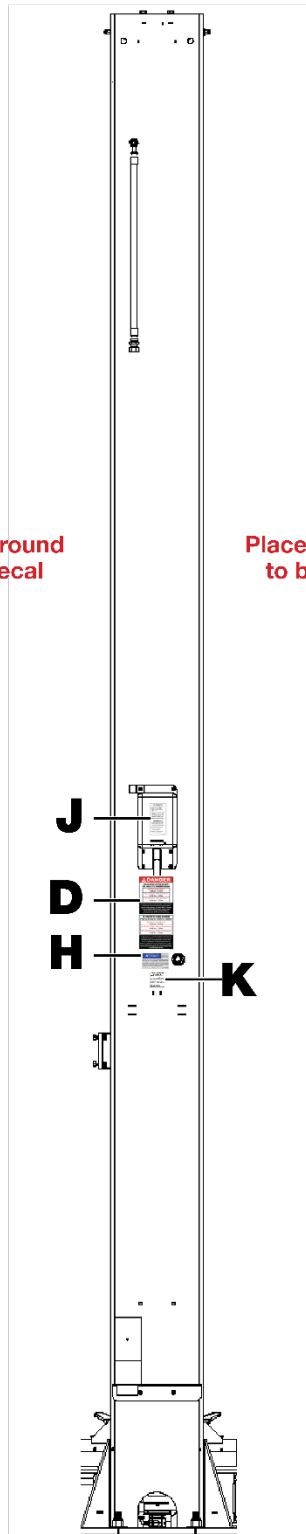

BACK OF POWERSIDE POST

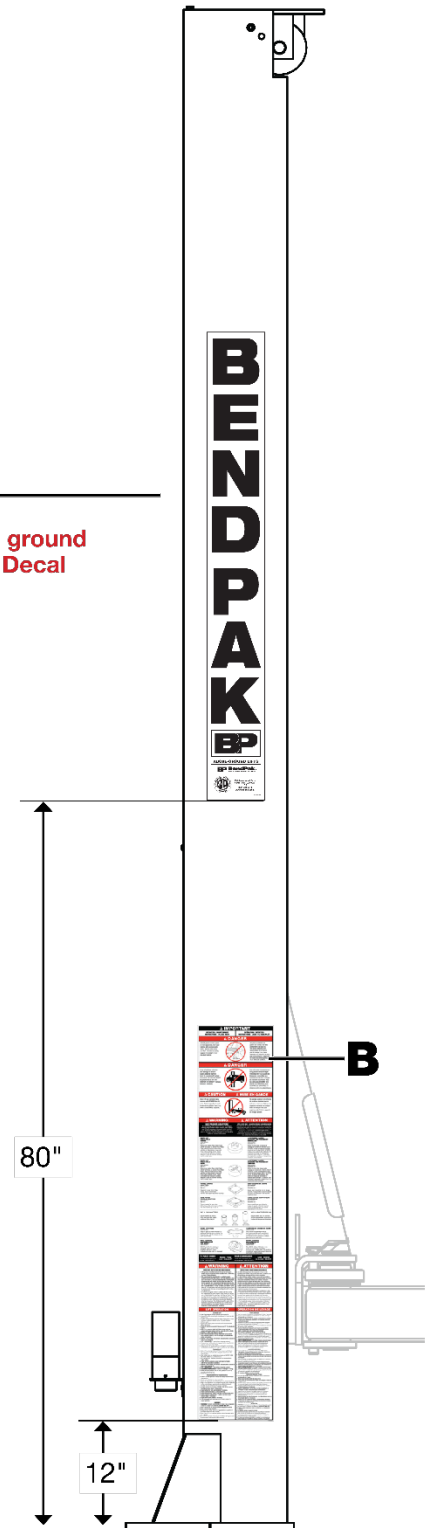

Parts Drawings

Model: 12APX

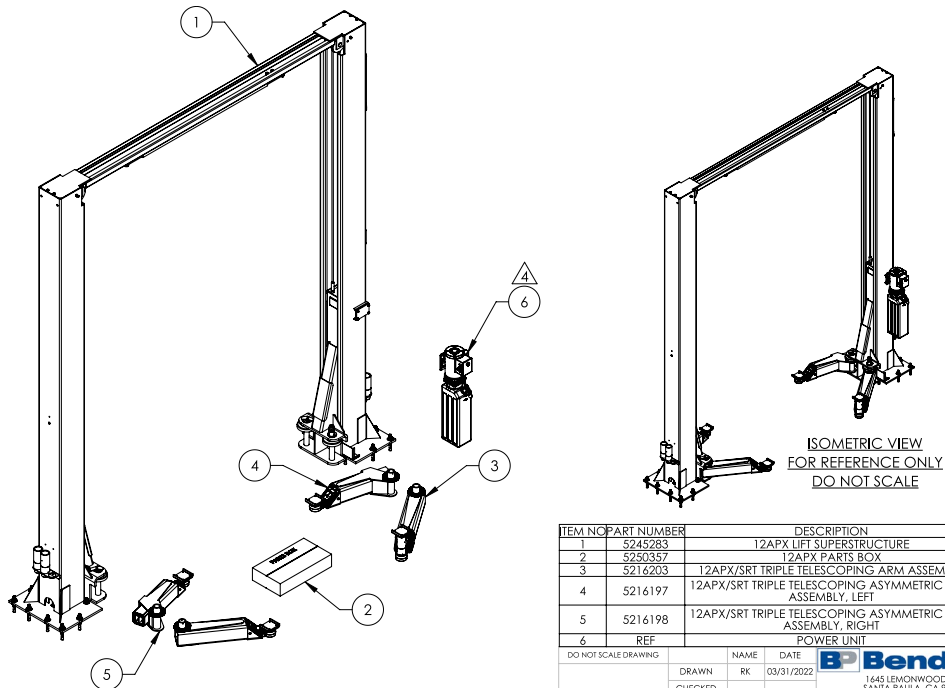

- NOTE: UNLESS OTHERWISE SPECIFIED**
1. REFER TO MODEL FOR ADDITIONAL INFORMATION
 2. SEE COLORS & GRAPHICS FOR LABEL PLACEMENT
 3. SEE SHIPPING INSTRUCTIONS FOR FINAL PACKAGING
 4. POWER UNIT REFERENCE ON PURCHASE ORDER

ITEM NO	PART NUMBER	DESCRIPTION	QTY	REV
1	5245283	12APX LIFT SUPERSTRUCTURE	1	F
2	5250357	12APX PARTS BOX	1	D
3	5216203	12APX/SRT TRIPLE TELESCOPING ARM ASSEMBLY	2	E
4	5216197	12APX/SRT TRIPLE TELESCOPING ASYMMETRIC ARM ASSEMBLY, LEFT	1	E
5	5216198	12APX/SRT TRIPLE TELESCOPING ASYMMETRIC ARM ASSEMBLY, RIGHT	1	E
6	REF	POWER UNIT	1	--

DO NOT SCALE DRAWING		NAME	DATE	 1445 LEMONWOOD DR. SANTA PAULA, CA 93060
DRAWN	RK	03/31/2022		
DIMENSIONS ARE IN MM		THIRD ANGLE PROJECTION		TITLE: 12APX PRODUCTION LIFT VER A SIZE: DWG. NO. 5260694 REV F
				SCALE: 1:35 SHEET 1 OF 3

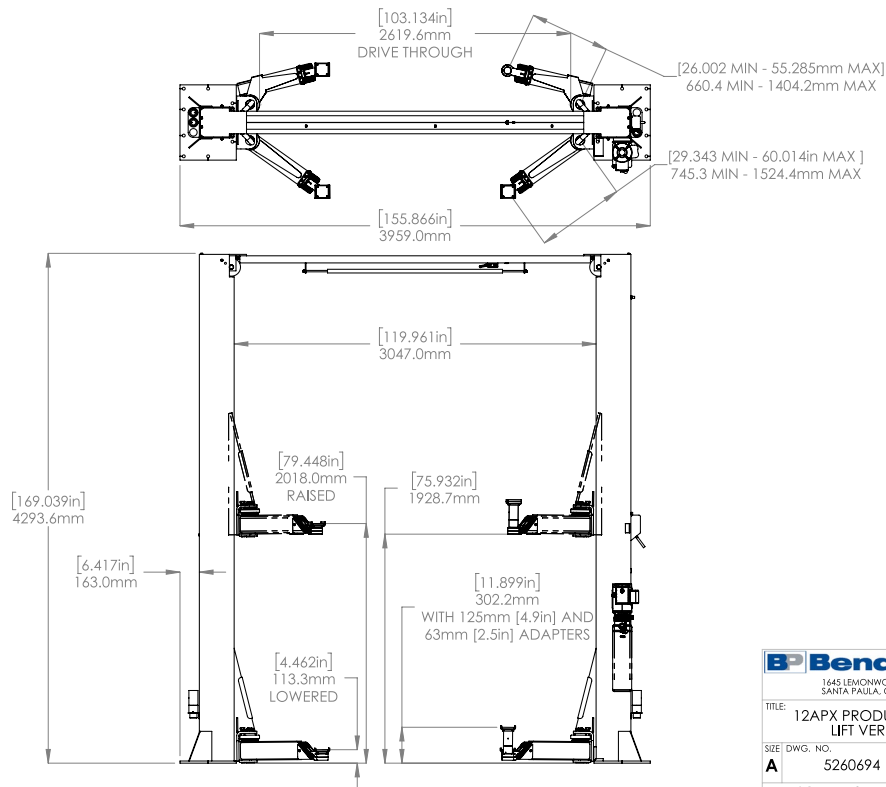

 1445 LEMONWOOD DR. SANTA PAULA, CA 93060	
TITLE: 12APX PRODUCTION LIFT VER A	
SIZE: DWG. NO. A 5260694	REV F
SCALE: 1:35 SHEET 2 OF 3	

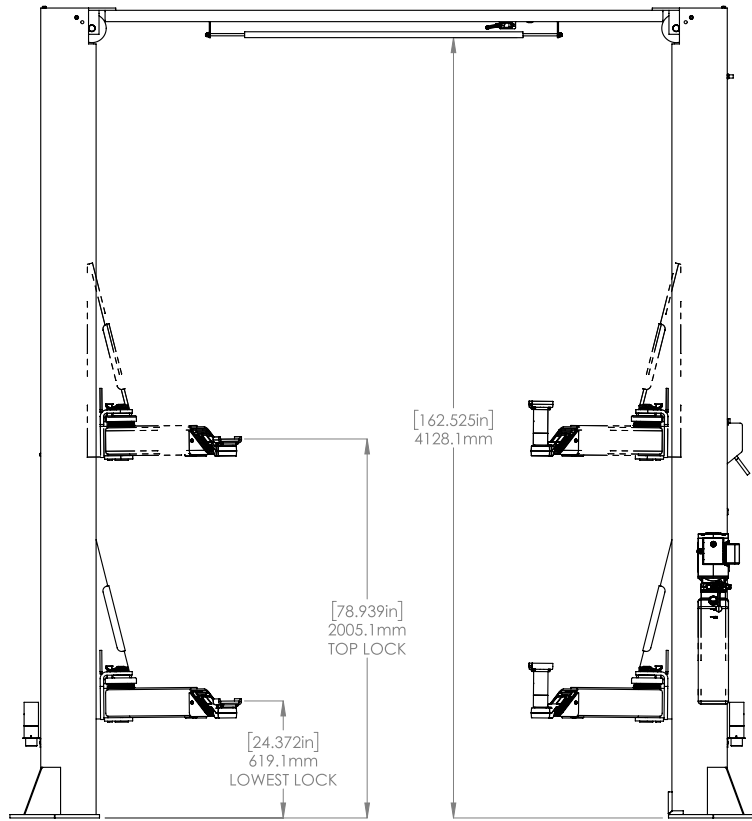

1. SAFETY LOCK POSITIONS: 15
2. SPACED EVERY: 99.0mm / 3.898"

BendPak
 1645 LEMONWOOD DR.
 SANTA PAULA, CA 92060

TITLE: 12APX PRODUCTION LIFT VER A

SIZE	DWG. NO.	REV
A	5260694	F

SCALE: 1:24 SHEET 3 OF 3

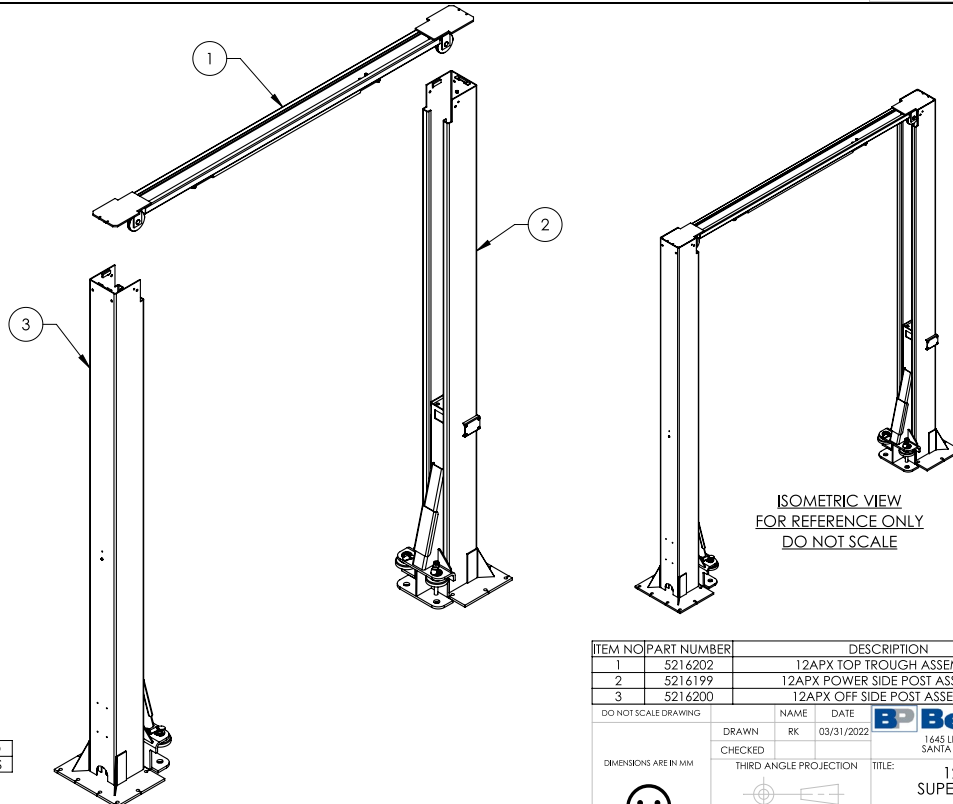

WHERE USED
12APX SERIES

- NOTE: UNLESS OTHERWISE SPECIFIED**
1. REFER TO MODEL FOR ADDITIONAL INFORMATION
 2. SEE SHIPPING INSTRUCTIONS FOR FINAL PACKAGING

NEXT ASSEMBLY
5260694
5260695

ITEM NO	PART NUMBER	DESCRIPTION	QTY	REV
1	5216202	12APX TOP TROUGH ASSEMBLY	1	B
2	5216199	12APX POWER SIDE POST ASSEMBLY	1	E
3	5216200	12APX OFF SIDE POST ASSEMBLY	1	F

DO NOT SCALE DRAWING

DRAWN	NAME	DATE
RK		03/31/2022

CHECKED

THIRD ANGLE PROJECTION

PROPRIETARY AND CONFIDENTIAL
 THE INFORMATION CONTAINED IN THIS DRAWING IS THE SOLE PROPERTY OF BENDPAK INC. ANY REPRODUCTION OR TRANSMISSION IN ANY FORM OR BY ANY MEANS WITHOUT THE WRITTEN PERMISSION OF BENDPAK INC. IS PROHIBITED.

BendPak
 1645 LEMONWOOD DR.
 SANTA PAULA, CA 92060

TITLE: 12APX LIFT SUPERSTRUCTURE

SIZE	DWG. NO.	REV
A	5245283	F

SCALE: 1:32 SHEET 1 OF 1

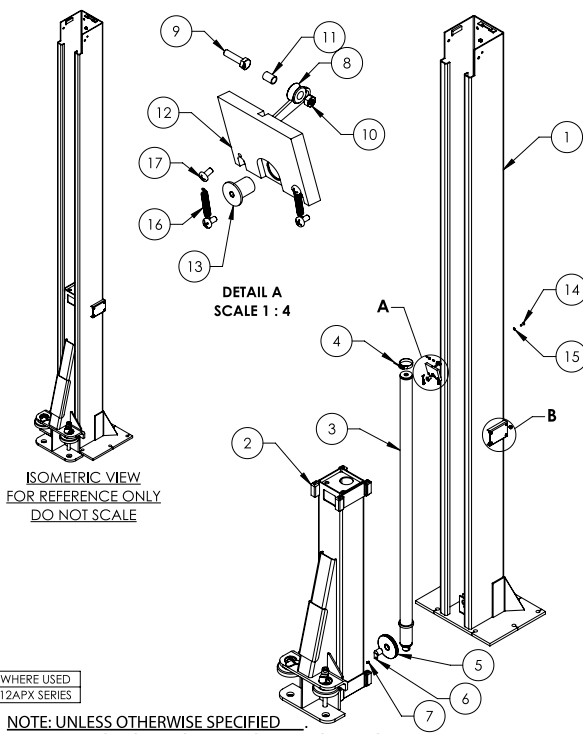

WHERE USED
12APX SERIES

- NOTE: UNLESS OTHERWISE SPECIFIED**
1. REFER TO MODEL FOR ADDITIONAL INFORMATION
 2. SEE SHIPPING INSTRUCTIONS FOR FINAL PACKAGING ASSEMBLE ITEMS AS SHOWN
 4. INSTALL RIVET NUTS INTO POST BRACKET AS SHOWN

NEXT ASSEMBLY
5245283

ITEM NO	PART NUMBER	DESCRIPTION	QTY	REV
1	5601901	12APX POWER SIDE POST WELDMENT	1	D
2	5216201	12APX LIFT HEAD ASSEMBLY	1	D
3	5502057	CYLINDER ASSEMBLY Ø2.5 x 75	1	C
4	5701115	CYLINDER CLAMP ASSY-74-79	1	-
5	5575113	12/16/20AP_XPR-12/15/18 SHEAVE ASSEMBLY	1	E
6	5620142	12/16/20AP_XPR-12/15/18C CABLE SHEAVE PIN WELDMENT	1	A
7	5530181	HHB M6 x 1.0 x 10 FT. CL 10.9	1	-
8	5575074	10/12/16/20AP SAFETY CABLE ROLLER	1	A
9	5530756	HHB M6 x 1.0 x 25 FT. CL 10.9	1	-
10	5535357	NUT M6 x 1.0 NL CL10.9	1	-
11	5565350	AP/GP/PCL/XPR/ PL-7000 SAFETY SHEAVE SPACER	1	C
12	5601905	12/16/20AP POWER SIDE SAFETY WELDMENT	1	B
13	5746494	10/12/16/20AP SAFETY PIVOT PIN	1	C
14	5530414	BHSK M8 x 1.25 x 25 CL10.9	1	-
15	5545202	WASHER M8 x Ø15 SL, CL10.9	1	-
16	5540047	EXTENSION SPRING Ø6.35 x 38mm	2	-
17	5530045	BHPS M5 x 0.8 x 10 FT. CL 8.8	4	-
18	5535057	NUT M8 x 1.25 x 17.5. RIVET	4	-

DO NOT SCALE DRAWING

NAME: **BP BendPak.**
DATE: 03/31/2022
DRAWN: RK
CHECKED: 1645 LEMONWOOD DR. SANTA PAULA, CA 93060

THIRD ANGLE PROJECTION

TITLE: 12APX POWER SIDE POST ASSEMBLY

SIZE: DWG. NO. **A** 5216199 REV **E**

SCALE: 1:25 SHEET 1 OF 1

PROPRIETARY AND CONFIDENTIAL
THE INFORMATION CONTAINED IN THIS DRAWING IS THE SOLE PROPERTY OF BENDPAK INC. REPRODUCTION IN ANY FORM OR BY ANY MEANS WITHOUT THE WRITTEN PERMISSION OF BENDPAK INC. IS PROHIBITED.

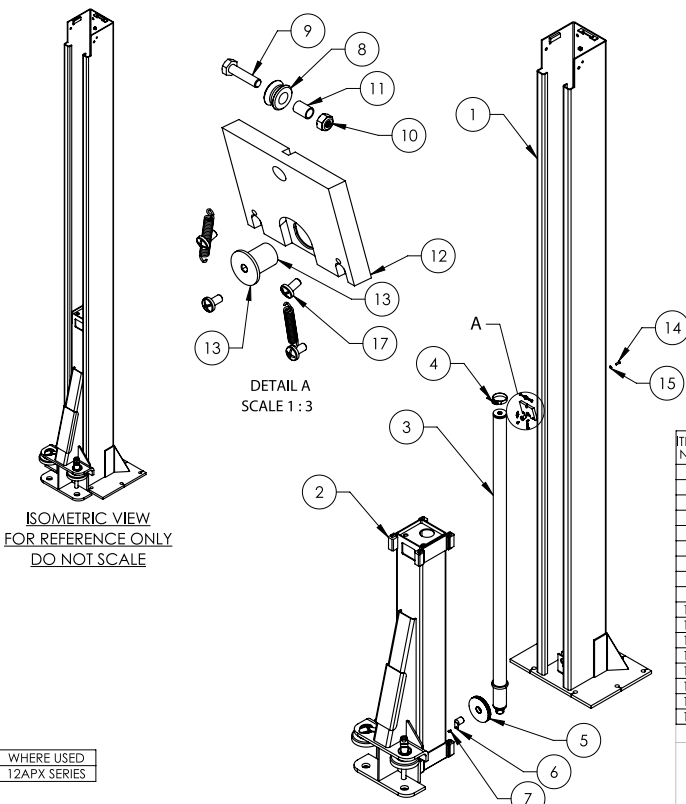

WHERE USED
12APX SERIES

- NOTE: UNLESS OTHERWISE SPECIFIED**
1. REFER TO MODEL FOR ADDITIONAL INFORMATION
 2. SEE SHIPPING INSTRUCTIONS FOR FINAL PACKAGING ASSEMBLE ITEMS AS SHOWN
 3. ASSEMBLE ITEMS AS SHOWN

NEXT ASSEMBLY
5245283

ITEM NO	PART NUMBER	DESCRIPTION	QTY	REV
1	5601902	12APX OFF SIDE POST WELDMENT	1	C
2	5216201	12APX LIFT HEAD ASSEMBLY	1	D
3	5502057	CYLINDER ASSEMBLY Ø2.5 x 75	1	C
4	5701115	CYLINDER CLAMP ASSY-74-79	1	-
5	5575113	12/16/20AP_XPR-12/15/18 SHEAVE ASSEMBLY	1	E
6	5620142	12/16/20AP_XPR-12/15/18C CABLE SHEAVE PIN WELDMENT	1	A
7	5530181	HHB M6 x 1.0 x 10 FT. CL 10.9	1	-
8	5575074	10/12/16/20AP SAFETY CABLE ROLLER	1	A
9	5530756	HHB M6 x 1.0 x 25 FT. CL 10.9	1	-
10	5535357	NUT M6 x 1.0 NL CL10.9	1	-
11	5565350	AP/GP/PCL/XPR/ PL-7000 SAFETY SHEAVE SPACER	1	C
12	5737354	12APX OFF SIDE SAFETY BLOCK	1	C
13	5746494	10/12/16/20AP SAFETY PIVOT PIN	1	C
14	5530414	BHSK M8 x 1.25 x 25 CL10.9	1	-
15	5545202	WASHER M8 x Ø15 SL, CL10.9	1	-
16	5540047	EXTENSION SPRING Ø6.35 x 38mm	2	-
17	5530045	BHPS M5 x 0.8 x 10 FT. CL 8.8	4	-

DO NOT SCALE DRAWING

NAME: **BP BendPak.**
DATE: 03/31/2022
DRAWN: RK
CHECKED: 1645 LEMONWOOD DR. SANTA PAULA, CA 93060

THIRD ANGLE PROJECTION

TITLE: 12APX OFF SIDE POST ASSEMBLY

SIZE: DWG. NO. **A** 5216200 REV **F**

SCALE: 1:25 SHEET 1 OF 1

PROPRIETARY AND CONFIDENTIAL
THE INFORMATION CONTAINED IN THIS DRAWING IS THE SOLE PROPERTY OF BENDPAK INC. REPRODUCTION IN ANY FORM OR BY ANY MEANS WITHOUT THE WRITTEN PERMISSION OF BENDPAK INC. IS PROHIBITED.

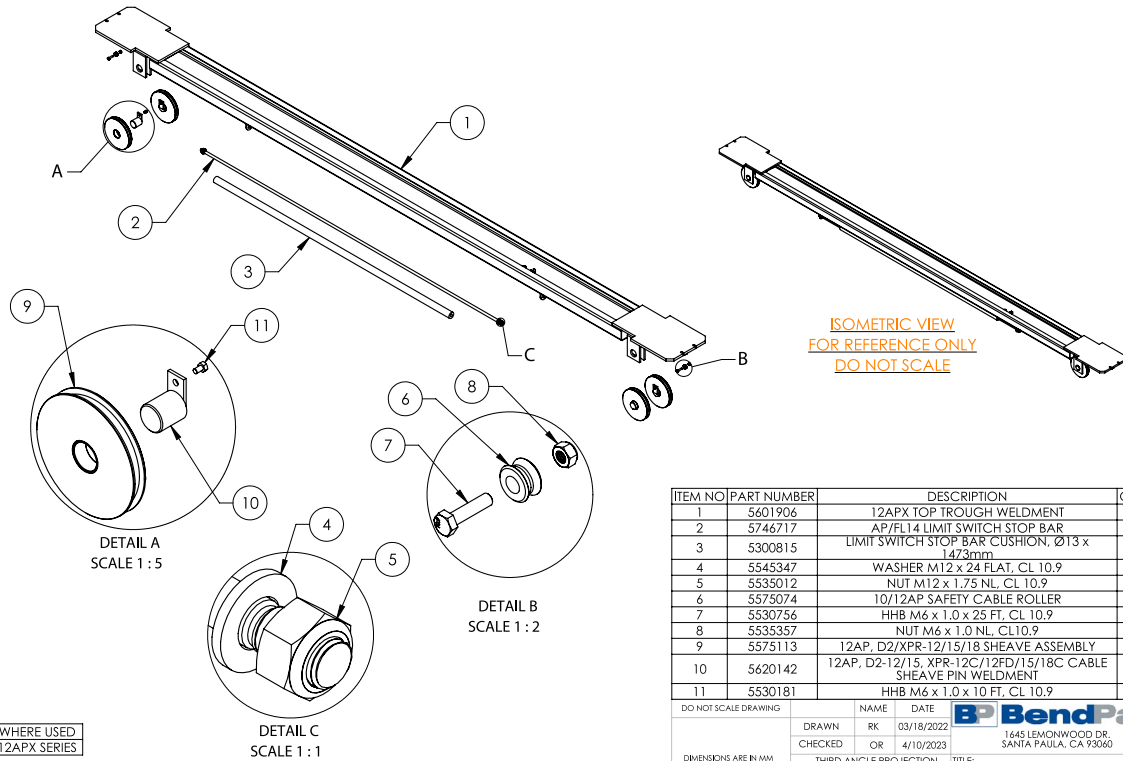

DETAIL A
SCALE 1 : 5

DETAIL B
SCALE 1 : 2

DETAIL C
SCALE 1 : 1

WHERE USED
12APX SERIES

- NOTE: UNLESS OTHERWISE SPECIFIED**
1. REFER TO MODEL FOR ADDITIONAL INFORMATION
 2. SEE SHIPPING INSTRUCTIONS FOR FINAL PACKAGING
 3. ASSEMBLE ITEMS AS SHOWN

NEXT ASSEMBLY
5245283

ITEM NO	PART NUMBER	DESCRIPTION	QTY	REV
1	5601906	12APX TOP TROUGH WELDMENT	1	B
2	5746717	AP/FL14 LIMIT SWITCH STOP BAR	1	A
3	5300815	LIMIT SWITCH STOP BAR CUSHION, Ø13 x 147.3mm	1	D
4	5545347	WASHER M12 x 24 FLAT, CL 10.9	2	-
5	5535012	NUT M12 x 1.75 NL, CL 10.9	2	-
6	5575074	10/12AP SAFETY CABLE ROLLER	2	A
7	5530756	HNB M6 x 1.0 x 25 FT, CL 10.9	2	-
8	5535357	NUT M6 x 1.0 NL, CL 10.9	2	-
9	5575113	12AP, D2/XPR-12/15/18 SHEAVE ASSEMBLY	4	E
10	5620142	12AP, D2-12/15, XPR-12C/12FD/15/18C CABLE SHEAVE PIN WELDMENT	4	A
11	5530181	HNB M6 x 1.0 x 10 FT, CL 10.9	4	-

DO NOT SCALE DRAWING

DRAWN: RK 03/18/2022
CHECKED: OR 4/10/2023

THIRD ANGLE PROJECTION

BP BendPak
1645 LEMONWOOD DR.
SANTA PAULA, CA 92060

TITLE: 12APX TOP TROUGH ASSEMBLY

SIZE: DWG. NO. 5216202 REV B

SCALE: 1:20 SHEET 1 OF 2

PROPRIETARY AND CONFIDENTIAL
THE INFORMATION CONTAINED IN THIS DRAWING IS THE SOLE PROPERTY OF BENDPAK INC. ANY REPRODUCTION OR TRANSMISSION OF THIS DRAWING WITHOUT THE WRITTEN PERMISSION OF BENDPAK INC. IS PROHIBITED.

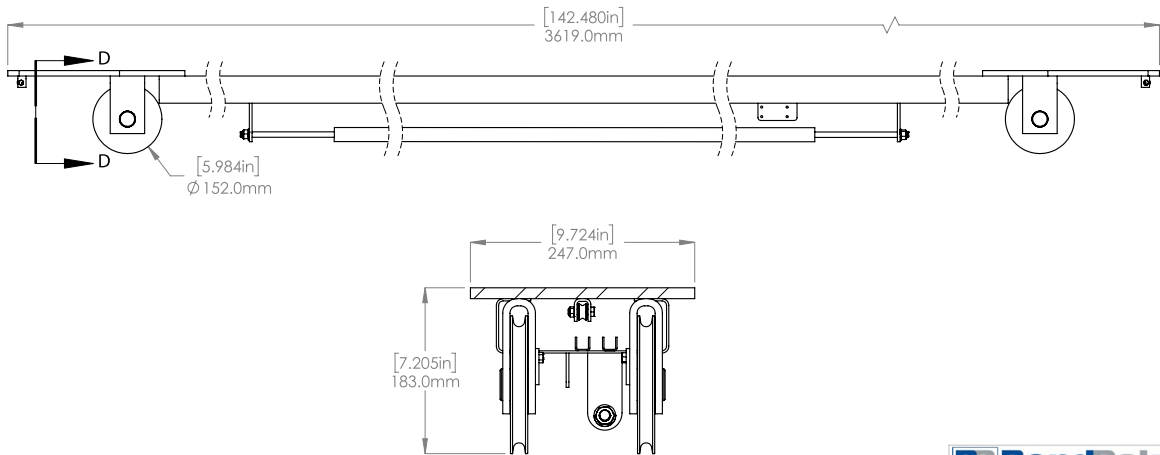

SECTION D-D
SCALE 1 : 5

BP BendPak
1645 LEMONWOOD DR.
SANTA PAULA, CA 92060

TITLE: 12APX TOP TROUGH ASSEMBLY

SIZE: DWG. NO. 5216202 REV B

SCALE: 1:10 SHEET 2 OF 2

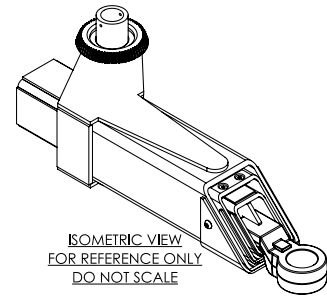
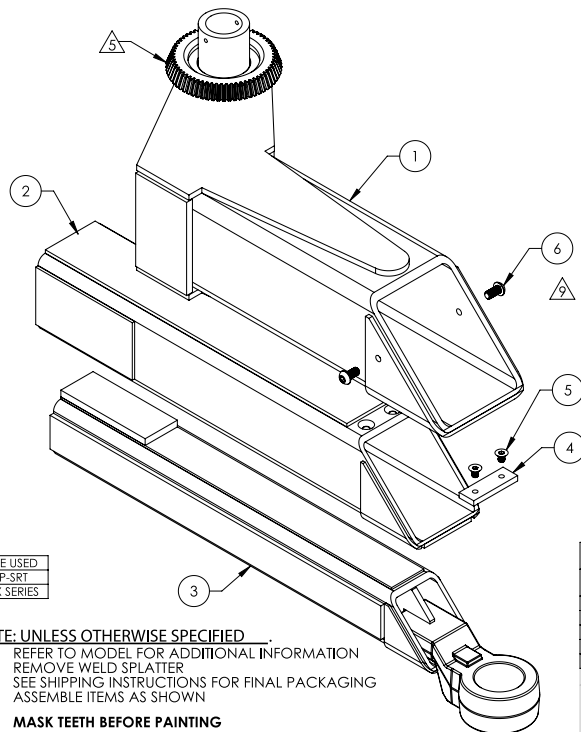

WHERE USED
12AP-SRT
12APX SERIES

- NOTE: UNLESS OTHERWISE SPECIFIED**
- REFER TO MODEL FOR ADDITIONAL INFORMATION
 - REMOVE WELD SPLATTER
 - SEE SHIPPING INSTRUCTIONS FOR FINAL PACKAGING ASSEMBLY ITEMS AS SHOWN
 - 5. MASK TEETH BEFORE PAINTING**
 - MASK BORE AND ALL THREADS BEFORE PAINTING
 - DIMENSIONS SHOWN ARE AFTER WELDING AND PAINTING
 - PAINT YELLOW (RAL-1018) 20% GLOSS
 - APPLY LOCTITE BLUE 242 AND CURE PER MANUFACTURE SPECIFICATION

NEXT ASSEMBLY
5240693
5240694
5240695

ITEM NO	PART NUMBER	DESCRIPTION	QTY	REV
1	5601899	12APX/SRT ASYMMETRIC ARM WELDMENT, OUTER SECTION, LEFT	1	D
2	5601898	12APX/SRT ASYMMETRIC ARM WELDMENT, MIDDLE SECTION	1	D
3	5601897	12APX/SRT ASYMMETRIC ARM WELDMENT, INNER SECTION	1	E
4	5737188	10/12AP MIDDLE ARM SECTION SLIDE STOP	1	B
5	5530382	FHSS M8 x 1.25 x 12 CL10.9	2	-
6	5530479	BHSS M10 x 1.5 x 20 FT. CL 10.9 B.O.	2	-

DO NOT SCALE DRAWING

DRAWN	NAME	DATE
RK		07/22/2022

CHECKED

DIMENSIONS ARE IN MM

THIRD ANGLE PROJECTION

PROPRIETARY AND CONFIDENTIAL
THE INFORMATION CONTAINED IN THIS DRAWING IS THE SOLE PROPERTY OF BENDPAK INC. ANY REPRODUCTION OR TRANSMISSION IN ANY FORM OR BY ANY MEANS WITHOUT THE WRITTEN PERMISSION OF BENDPAK INC. IS PROHIBITED.

1645 LEMONWOOD DR.
SANTA PAULA, CA 93060

TITLE: 12APX/SRT TRIPLE TELESCOPING ASYMMETRIC ARM ASSEMBLY, LEFT

SIZE: DWG. INCH: A

DWG. NO.: 5216197

REV: E

SCALE: 1:5

SHEET 2 OF 2

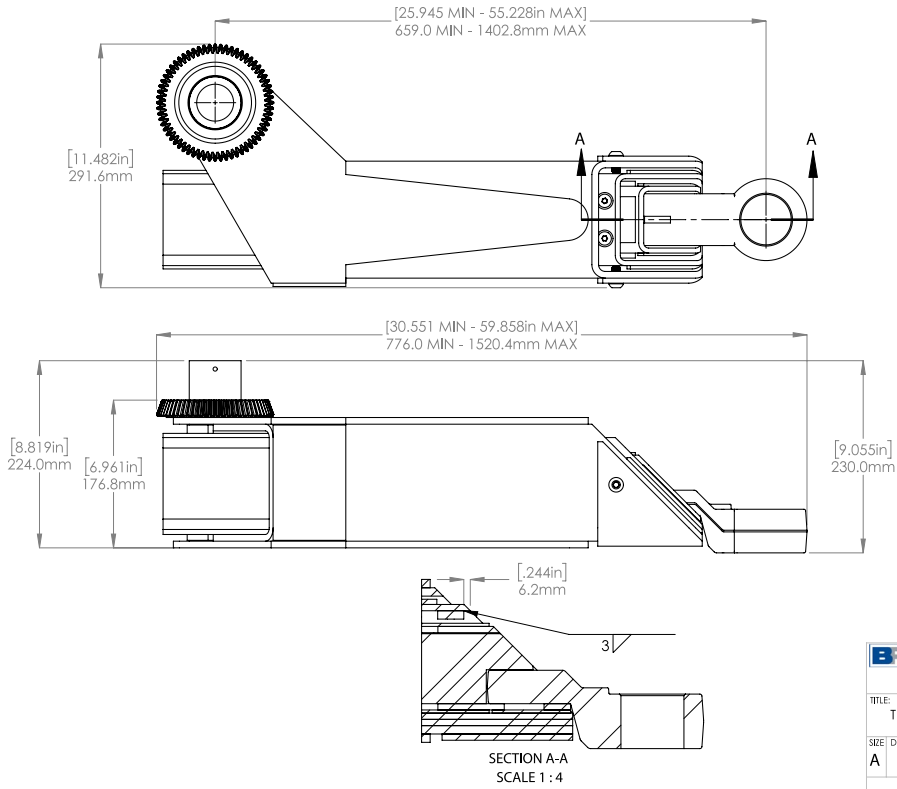

BendPak	
1645 LEMONWOOD DR. SANTA PAULA, CA 93060	
TITLE: 12APX/SRT TRIPLE TELESCOPING ASYMMETRIC ARM ASSEMBLY, LEFT	
SIZE: DWG. NO.:	REV:
A	5216197
SCALE: 1:5	
SHEET 2 OF 2	

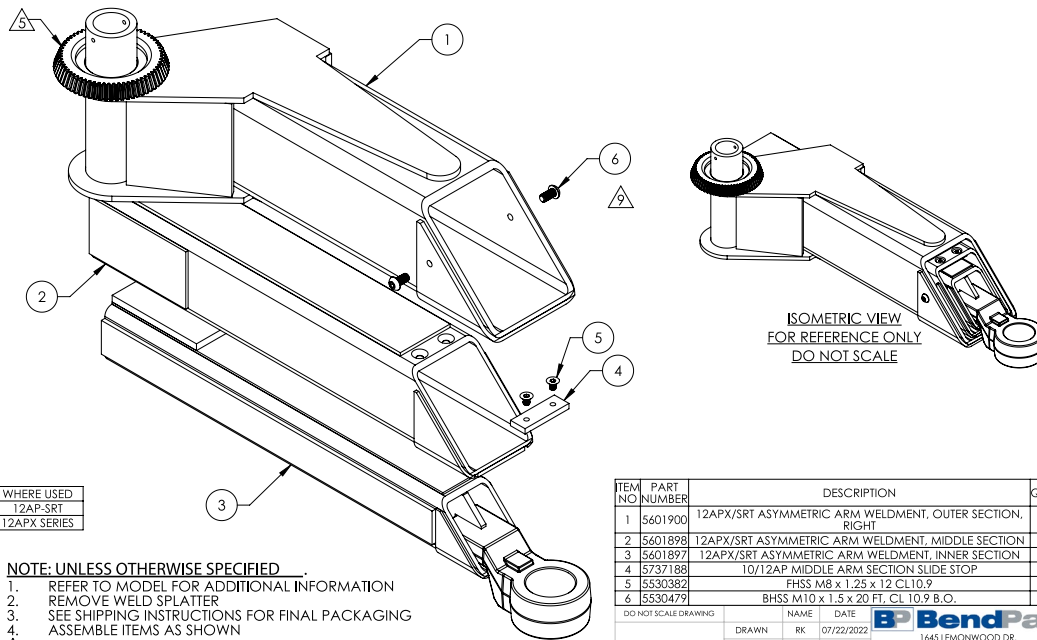

WHERE USED
12AP-SRT
12APX SERIES

- NOTE: UNLESS OTHERWISE SPECIFIED**
- REFER TO MODEL FOR ADDITIONAL INFORMATION
 - REMOVE WELD SPLATTER
 - SEE SHIPPING INSTRUCTIONS FOR FINAL PACKAGING ASSEMBLE ITEMS AS SHOWN
 - ASSEMBLE ITEMS AS SHOWN
 - MASK TEETH BEFORE PAINTING**
 - MASK BORE AND ALL THREADS BEFORE PAINTING
 - DIMENSIONS SHOWN ARE AFTER WELDING AND PAINTING
 - PAINTE YELLOW (RAL-1018) 20% GLOSS
 - APPLY LOCTITE BLUE 242 AND CURE PER MANUFACTURE SPECIFICATION

NEXT ASSEMBLY
5240693
5240694
5240695

ITEM NO	PART NUMBER	DESCRIPTION	QTY	REV
1	5601900	12APX/SRT ASYMMETRIC ARM WELDMENT, OUTER SECTION, RIGHT	1	D
2	5601898	12APX/SRT ASYMMETRIC ARM WELDMENT, MIDDLE SECTION	1	D
3	5601897	12APX/SRT ASYMMETRIC ARM WELDMENT, INNER SECTION	1	E
4	5737188	10/12AP MIDDLE ARM SECTION SLIDE STOP	1	B
5	5530382	FHSS M8 x 1.25 x 12 CL10.9	2	-
6	5530479	BHSS M10 x 1.5 x 20 FT. CL 10.9 B.O.	2	-

DO NOT SCALE DRAWING

DRAWN	CHKD	DATE
		07/22/2022

CHECKED

DIMENSIONS ARE IN MM

THIRD ANGLE PROJECTION

PROPRIETARY AND CONFIDENTIAL: THE INFORMATION CONTAINED IN THIS DRAWING IS THE SOLE PROPERTY OF BENDPAK INC. ANY REPRODUCTION OR TRANSMISSION OF THIS DRAWING WITHOUT THE WRITTEN PERMISSION OF BENDPAK INC. IS PROHIBITED.

1645 LEMONWOOD DR.
SANTA PAULA, CA 93060

TITLE: 12APX/SRT TRIPLE TELESCOPING ASYMMETRIC ARM ASSEMBLY, RIGHT

SIZE: DWG. NO. 5216198 REV E

SCALE: 1:5 SHEET 1 OF 2

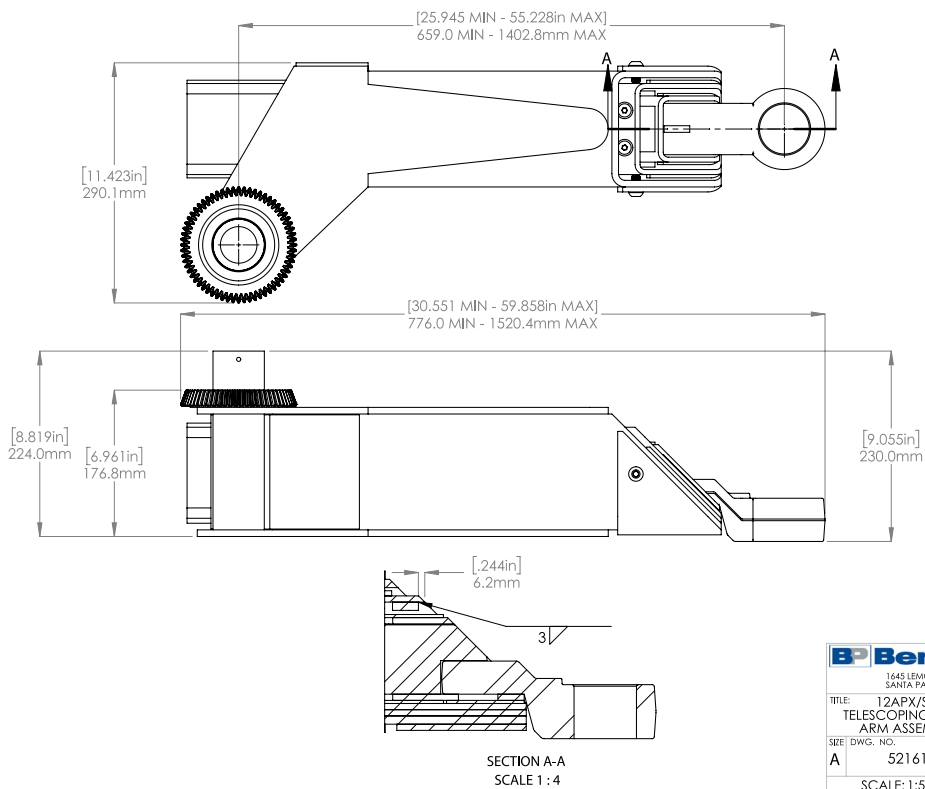

BendPak	
1645 LEMONWOOD DR. SANTA PAULA, CA 93060	
TITLE: 12APX/SRT TRIPLE TELESCOPING ASYMMETRIC ARM ASSEMBLY, RIGHT	
SIZE: DWG. NO. A	REV E
5216198	
SCALE: 1:5	SHEET 2 OF 2

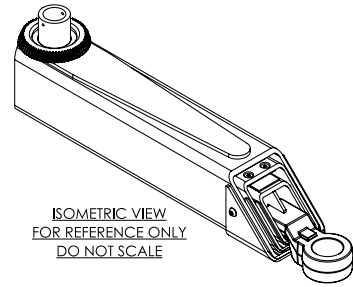
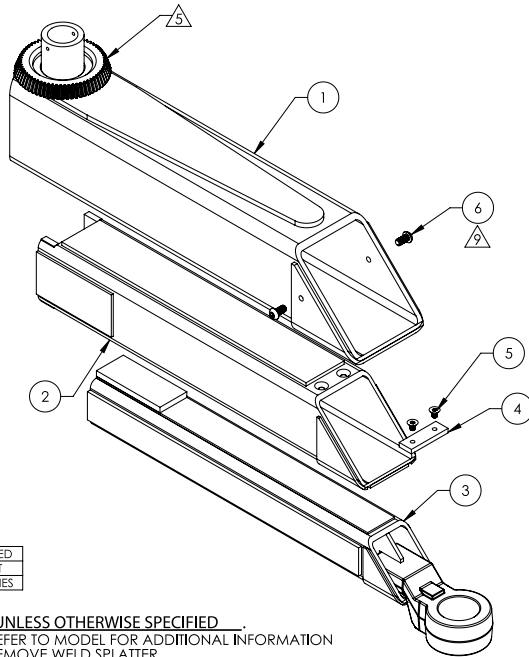

ISOMETRIC VIEW
FOR REFERENCE ONLY
DO NOT SCALE

WHERE USED
12AP-SRT
12APX SERIES

- NOTE: UNLESS OTHERWISE SPECIFIED**
- REFER TO MODEL FOR ADDITIONAL INFORMATION
 - REMOVE WELD SPLATTER
 - SEE SHIPPING INSTRUCTIONS FOR FINAL PACKAGING ASSEMBLE ITEMS AS SHOWN
 - ASSEMBLE ITEMS AS SHOWN
 - MASK TEETH BEFORE PAINTING**
 - MASK BORE AND ALL THREADS BEFORE PAINTING
 - DIMENSIONS SHOWN ARE AFTER WELDING AND PAINTING
 - PAINT YELLOW (RAL-1018) 20% GLOSS
 - APPLY LOCTITE BLUE 242 AND CURE PER MANUFACTURE SPECIFICATION

ITEM NO	PART NUMBER	DESCRIPTION	QTY	REV
1	5601907	12APX/SRT ARM WELDMENT, OUTER SECTION	1	D
2	5601908	12APX/SRT ARM WELDMENT, MIDDLE SECTION	1	E
3	5601909	12APX/SRT ARM WELDMENT, INNER SECTION	1	E
4	5737188	10/12AP MIDDLE ARM SECTION SLIDE STOP	1	B
5	5530382	FHSS M8 x 1.25 x 12 CL10.9	2	-
6	5530479	BHSS M10 x 1.5 x 20 FT. CL10.9 B.O.	2	-

NEXT ASSEMBLY
5260693
5260694
5260695

DO NOT SCALE DRAWING

DRAWN	BK	03/23/2022
CHECKED		

NAME: **BendPak**
DATE: 03/23/2022
1645 LEMONWOOD DR.
SANTA PAULA, CA 95060

THIRD ANGLE PROJECTION

EMPHASIS ARE IN INM

PROPRIETARY AND CONFIDENTIAL
THE INFORMATION CONTAINED IN THIS DRAWING IS
THE SOLE PROPERTY OF BENDPAK INC. ANY
REPRODUCTION OR TRANSMISSION WITHOUT
THE WRITTEN PERMISSION OF BENDPAK INC. IS
PROHIBITED.

TITLE: 12APX/SRT TRIPLE
TELESCOPING ARM ASSEMBLY

SIZE: DWG. NO. 5216203 REV E

SCALE: 1:6 SHEET 1 OF 2

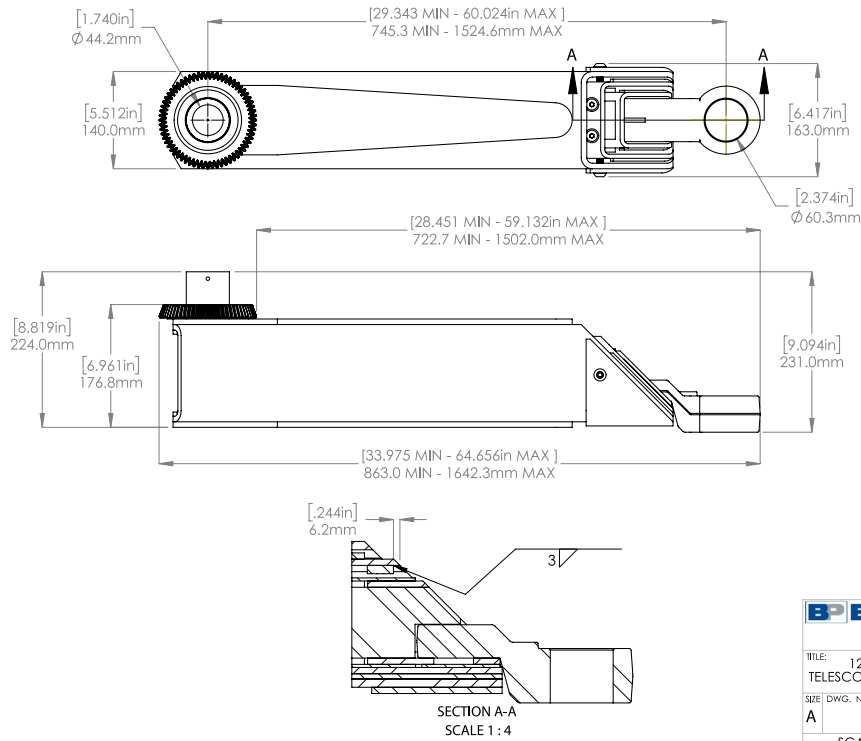

BendPak
1645 LEMONWOOD DR.
SANTA PAULA, CA 95060

TITLE: 12APX/SRT TRIPLE
TELESCOPING ARM ASSEMBLY

SIZE: DWG. NO. 5216203 REV E

SCALE: 1:6 SHEET 2 OF 2

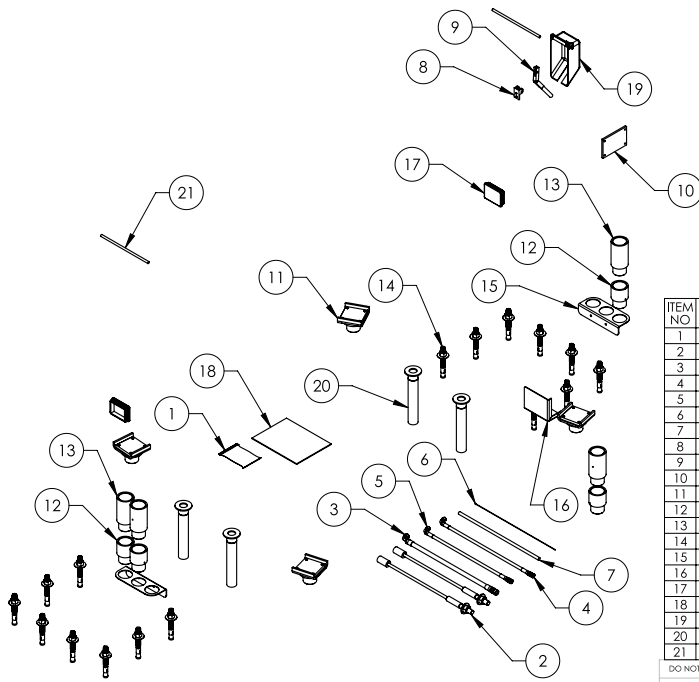

WHERE USED
12APX

NOTE: UNLESS OTHERWISE SPECIFIED

1. REFER TO MODEL FOR ADDITIONAL INFORMATION
2. INSERT PARTS BAG INTO PARTS BOX FOR SHIPMENT
3. HOSES AND CABLES SHOWN REPRESENTATIONAL FORM

NEXT ASSEMBLY
5260693

ITEM NO	PART NUMBER	DESCRIPTION	QTY	REV
1	5174126	12APX SERIES PARTS BAG	1	C
2	5595758	CABLE ASSEMBLY Ø12 x 10440mm ST	2	B
3	5570290	HYDRAULIC HOSE ASSEMBLY Ø10 x 2790mm SB	1	B
4	5570238	HYDRAULIC HOSE ASSEMBLY Ø6.4 x 3870mm SB	1	A
5	5570254	HYDRAULIC HOSE ASSEMBLY Ø6.35 x 7950mm SB	1	B
6	5595759	SAFETY CABLE Ø1.8 x 8850mm	1	B
7	5520032	CABLE, AWG 14-2, SOOW	4165mm	-
8	5700404	AP SAFETY PIVOT HOLDER	1	C
9	5761017	AP SAFETY HANDLE	1	E
10	5715003	POWER UNIT VIBRATION DAMPENER	1	B
11	5215702	CRADLE LIFT PAD LARGE ADAPTER ASSEMBLY	4	F
12	5746192	ARM ADAPTER, MEDIUM	4	F
13	5746193	ARM ADAPTER, LONG	4	E
14	5530337	AB 3/4" x 6.3"	16	-
15	5701660	HEIGHT ADAPTER HOLDER, 60mm PIN	2	B
16	5701901	12APX FOOT GUARD	1	B
17	5715196	POLYETHYLENE COVER BLOCK 105 x 80	2	D
18	5900374	12APX INSTALLATION MANUAL	1	-
19	5716072	AP POWER SIDE PLASTIC SAFETY COVER	1	A
20	5601910	12APX/SRT ARM LOCK PIN WELDMENT, Ø44	4	B
21	5746166	DOUBLE THREADED ROD M10 x 1.5 x 295	2	B

DO NOT SCALE DRAWING

DRAWN CA 08/02/2022

CHECKED

THIRD ANGLE PROJECTION

SMILEY FACE

PROPRIETARY AND CONFIDENTIAL
THE INFORMATION CONTAINED IN THIS DRAWING IS THE SOLE PROPERTY OF BENDPAK INC. AND IS NOT TO BE REPRODUCED OR TRANSMITTED IN ANY FORM OR BY ANY MEANS, WITHOUT THE WRITTEN PERMISSION OF BENDPAK INC.

BendPak.
1645 LEMONWOOD DR.
SANTA PAULA, CA 93060

TITLE: 12APX PARTS BOX

SIZE DWG. NO. A 5250357

REV D

SCALE: 1:20 SHEET 1 OF 1

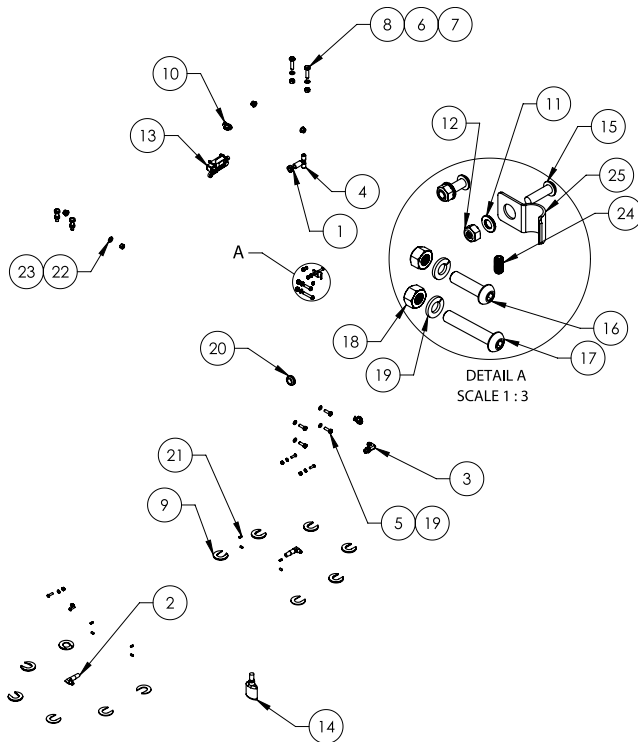

WHERE USED
12APX SERIES

NOTE: UNLESS OTHERWISE SPECIFIED

1. SEE SHIPPING INSTRUCTIONS FOR FINAL PACKAGING

NEXT ASSEMBLY
5250357
5250358

ITEM NO	PART NUMBER	DESCRIPTION	QTY	REV
1	5535022	NUT 9/16"-18 IN. Gr 5	1	-
2	5550113	FTG ELB -04 NPT L x -04 JIC	2	-
3	5550183	FTG ELB -06 JIC -06L ORB	1	-
4	5550003	FTG TEE -04JIC -04JIC -06JIC	1	-
5	5530010	HHB M8 x 1.25 x 25 FT, CL 10.9	4	-
6	5545200	WASHER M10 x Ø18 SL, CL 10.9	4	-
7	5535998	NUT M10 x 1.5, CL 10.9	4	-
8	5530302	HHB M10 x 1.5 x 40 FT, CL 10.9	4	-
9	5545535	C WASHER SHIM FOR LIFTS	20	-
10	5520140	ROMEX CONNECTOR 3/8 #6623	2	-
11	5545005	WASHER M6 x 12 FLAT, CL 10.9	6	-
12	5535357	NUT M6 x 1.0 NL, CL 10.9	6	-
13	5520088	ROCKER LIMIT SWITCH, 25A	1	-
14	5580012	LIQUID PTFE THREAD SEALANT 50ml	1	-
15	5530065	BHSK M6 x 1.0 x 20 FT, CL 10.9	6	-
16	5530412	BHSK M8 x 1.25 x 30 CL 10.9	1	-
17	5530413	BHSK M8 x 1.25 x 45 CL 10.9	1	-
18	5535001	NUT M8 x 1.25 NL, CL 10.9	2	-
19	5545202	WASHER M8 x Ø15 SL, CL 10.9	6	-
20	5520001	RUBBER GROMMET, 3/4 I.D.	1	-
21	5530423	SSS M6 x 1.0 x 12 CONE, CL 10.9	8	-
22	5545341	WASHER M10 x Ø20 FLAT, CL 10.9	4	-
23	5535013	NUT M10 x 1.5 NL, CL 10.9	4	-
24	5530460	SSS M6 x 1.0 x 12 NL FLAT	1	-
25	5505051	Ø10mm PIPE STRAP	1	A

DO NOT SCALE DRAWING

DRAWN TM 03/31/2023

CHECKED

THIRD ANGLE PROJECTION

SMILEY FACE

PROPRIETARY AND CONFIDENTIAL
THE INFORMATION CONTAINED IN THIS DRAWING IS THE SOLE PROPERTY OF BENDPAK INC. AND IS NOT TO BE REPRODUCED OR TRANSMITTED IN ANY FORM OR BY ANY MEANS, WITHOUT THE WRITTEN PERMISSION OF BENDPAK INC.

BendPak.
1645 LEMONWOOD DR.
SANTA PAULA, CA 93060

TITLE: 12APX SERIES PARTS BAG

SIZE DWG. NO. A 5174126

REV C

SCALE: 1:16 SHEET 1 OF 1

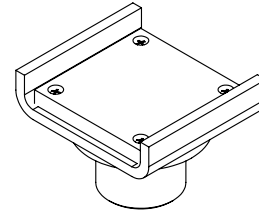
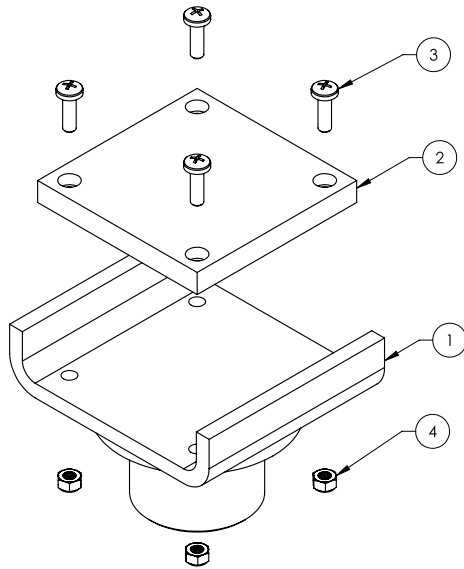

ISOMETRIC VIEW
FOR REFERENCE ONLY
DO NOT SCALE

WHERE USED
12AP SERIES
16AP SERIES
20AP SERIES
XPR-12FDL SERIES
XPR-12CL SERIES
XPR-15 SERIES
XPR-18 SERIES

NOTE: UNLESS OTHERWISE SPECIFIED

1. REFER TO MODEL FOR ADDITIONAL INFORMATION
2. SEE SHIPPING INSTRUCTIONS FOR FINAL PACKAGING
3. ASSEMBLE ITEMS AS SHOWN

ITEM NO	PART NUMBER	DESCRIPTION	QTY	REV
1	5601000	CRADLE LIFT PAD WELDMENT	1	D
2	5715020	CRADLE LIFT PAD LARGE POLYURETHANE PAD	1	C
3	5530022	PHPS M6 x 1 x 20mm ZPL	4	--
4	5535357	NUT M6 x 1.0 NL	4	--

DO NOT SCALE DRAWING	NAME	DATE	BendPak	
	DRAWN JM	06/24/2015	1645 LEMONWOOD DR. SANTA PAULA, CA 93060	
	CHECKED		TITLE: CRADLE LIFT PAD LARGE ADAPTER ASSEMBLY	
	THIRD ANGLE PROJECTION		SIZE	REV
	DIMENSIONS ARE IN MM		A	F
			DWG. NO.	SCALE: 1:2
	<small>PROPRIETARY AND CONFIDENTIAL THE INFORMATION CONTAINED IN THIS DRAWING IS THE SOLE PROPERTY OF BENDPAK INC. ANY REPRODUCTION IN PART OR AS A WHOLE WITHOUT THE WRITTEN PERMISSION OF BENDPAK INC. IS PROHIBITED.</small>		5215702	SHEET 1 OF 1

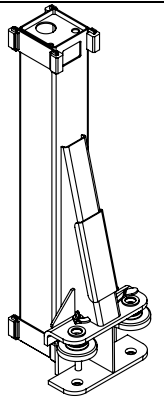

ISOMETRIC VIEW
FOR REFERENCE ONLY
DO NOT SCALE

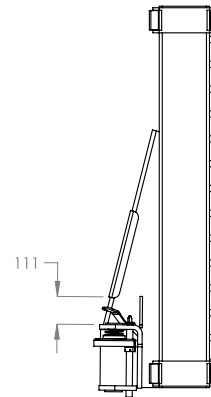
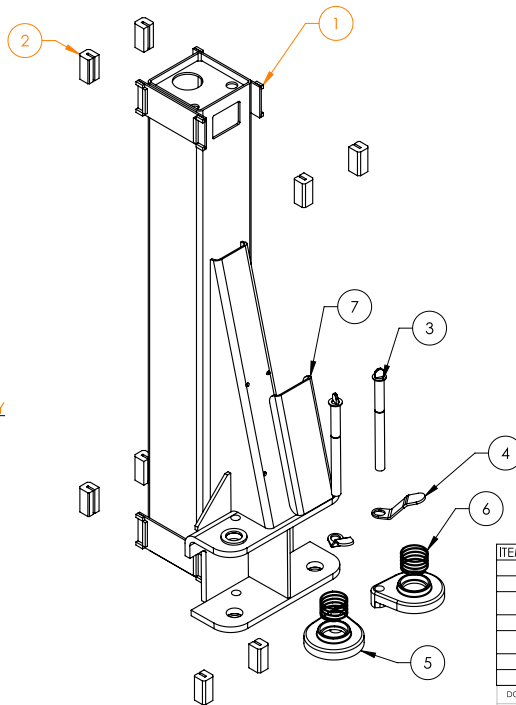

WHERE USED
12APX SERIES

NOTE: UNLESS OTHERWISE SPECIFIED

1. REFER TO MODEL FOR ADDITIONAL INFORMATION
2. SEE SHIPPING INSTRUCTIONS FOR FINAL PACKAGING
3. ASSEMBLE ITEMS AS SHOWN

NEXT ASSEMBLY
5216199
5216200

ITEM NO	PART NUMBER	DESCRIPTION	QTY	REV
1	5601903	12APX LIFT HEAD WELDMENT	1	C
2	5716001	2 POST GUIDE BLOCK	8	H
3	5602030	12APX/SRT ARM LOCK GUIDE ROD WELDMENT, GROOVE	2	A
4	5701700	AP ARM LOCK RELEASE HANDLE	2	C
5	5701954	10/12AP ARM INTERNAL FULL CIRCLE GEAR STOP, THREADED HOLES	2	A
6	5540044	COMPRESSION SPRING Ø74 x 40mm	2	-
7	5930004	12/16/20AP LIFT HEAD GUSSET COVER	1	B

DO NOT SCALE DRAWING	NAME	DATE	BendPak	
	DRAWN RK	03/31/2022	1645 LEMONWOOD DR. SANTA PAULA, CA 93060	
	CHECKED		TITLE: 12APX LIFT HEAD ASSEMBLY	
	THIRD ANGLE PROJECTION		SIZE	REV
	DIMENSIONS ARE IN MM		A	D
			DWG. NO.	SCALE: 1:12
	<small>PROPRIETARY AND CONFIDENTIAL THE INFORMATION CONTAINED IN THIS DRAWING IS THE SOLE PROPERTY OF BENDPAK INC. ANY REPRODUCTION IN PART OR AS A WHOLE WITHOUT THE WRITTEN PERMISSION OF BENDPAK INC. IS PROHIBITED.</small>		5216201	SHEET 1 OF 2

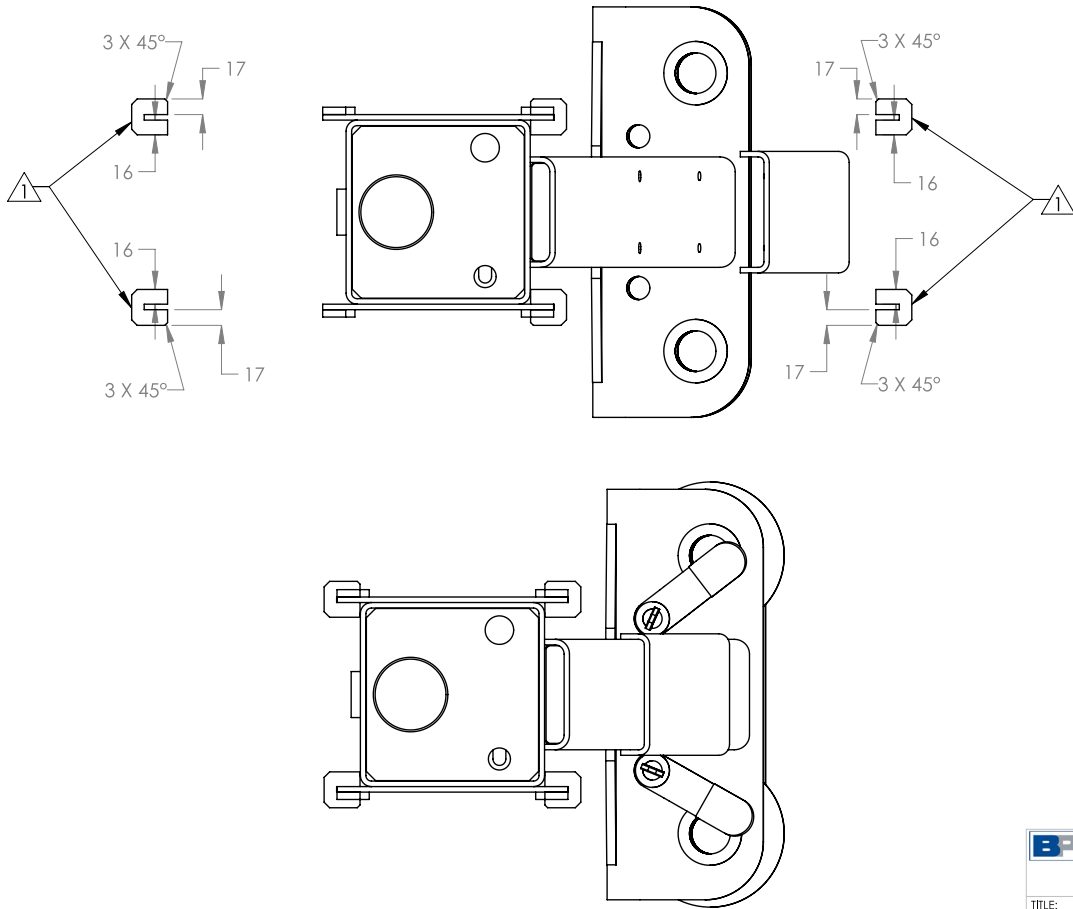

TOP VIEW

NOTE: UNLESS OTHERWISE SPECIFIED

 NOTE ORIENTATION OF PLASTIC GUIDE BLOCK

		
1645 LEMONWOOD DR. SANTA PAULA, CA 93060		
TITLE: 12APX LIFT HEAD ASSEMBLY		
SIZE	DWG. NO.	REV
A	5216201	D
SCALE: 1:10		SHEET 2 OF

Model: 12APX-192

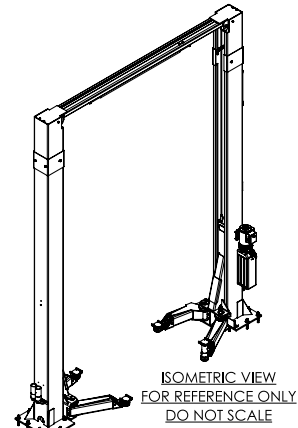
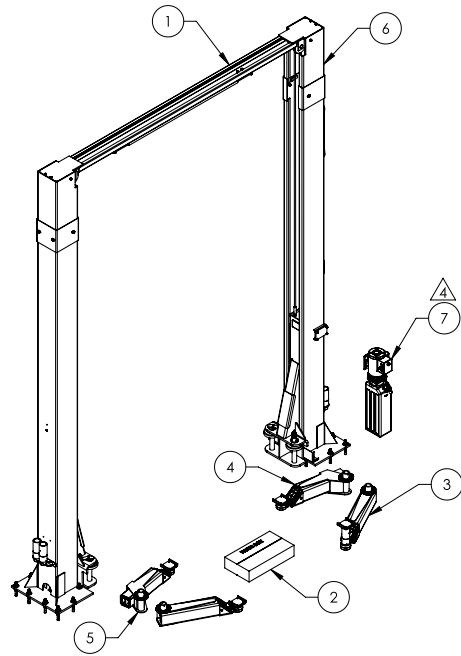

- NOTE: UNLESS OTHERWISE SPECIFIED**
1. REFER TO MODEL FOR ADDITIONAL INFORMATION
 2. SEE COLORS & GRAPHICS FOR LABEL PLACEMENT
 3. SEE SHIPPING INSTRUCTIONS FOR FINAL PACKAGING
 4. POWER UNIT REFERENCE ON PURCHASE ORDER

ITEM NO	PART NUMBER	DESCRIPTION	QTY	REV
1	5245283	12APX LIFT SUPERSTRUCTURE	1	F
2	5250358	12APX-192 PARTS BOX	1	D
3	5216203	12APX/SRT TRIPLE TELESCOPING ARM ASSEMBLY	2	E
4	5216197	12APX/SRT TRIPLE TELESCOPING ASYMMETRIC ARM ASSEMBLY LEFT	1	E
5	5216198	12APX/SRT TRIPLE TELESCOPING ASYMMETRIC ARM ASSEMBLY RIGHT	1	E
6	5216204	12APX/16/20AP-192 POST EXTENSION ASSEMBLY	2	C
7	REF	POWER UNIT	1	-

DO NOT SCALE DRAWING		NAME	DATE	
DRAWN	RK	03/31/2022	1645 LEMONWOOD DR. SANTA PAULA, CA 93060	
DIMENSIONS ARE IN MM		CHECKED		TITLE: 12APX-192 PRODUCTION LIFT VER A
THIRD ANGLE PROJECTION				SIZE DWG. NO. REV
		<small>PROPRIETARY AND CONFIDENTIAL THE INFORMATION CONTAINED IN THIS DRAWING IS THE SOLE PROPERTY OF BENDPAK INC. ANY REPRODUCTION IN ANY FORM OR BY ANY MEANS WITHOUT THE WRITTEN PERMISSION OF BENDPAK INC. IS PROHIBITED.</small>		A 5260695 F
SCALE: 1:40				SHEET 1 OF 3

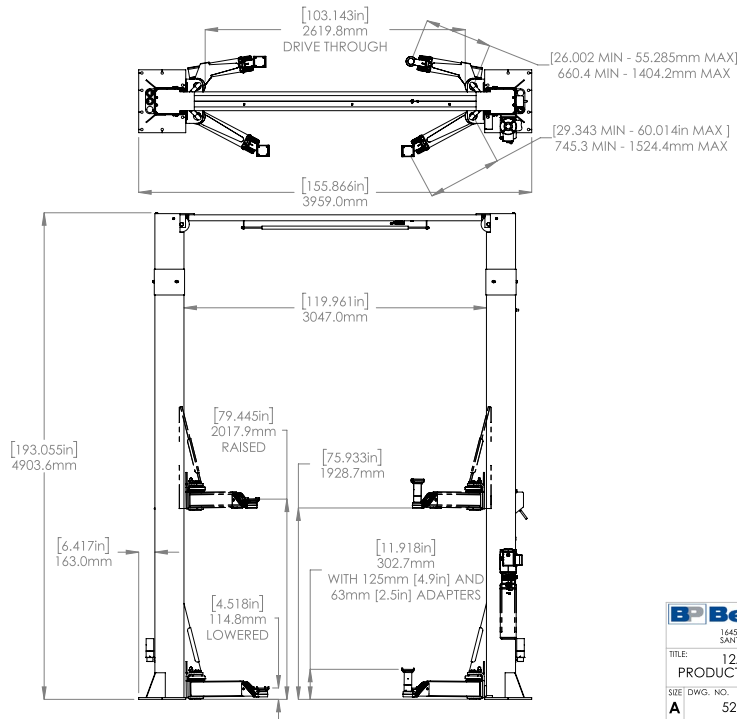

1645 LEMONWOOD DR. SANTA PAULA, CA 93060	
TITLE: 12APX-192 PRODUCTION LIFT VER A	
SIZE DWG. NO.	REV
A 5260695	F
SCALE: 1:38	
SHEET 2 OF 3	

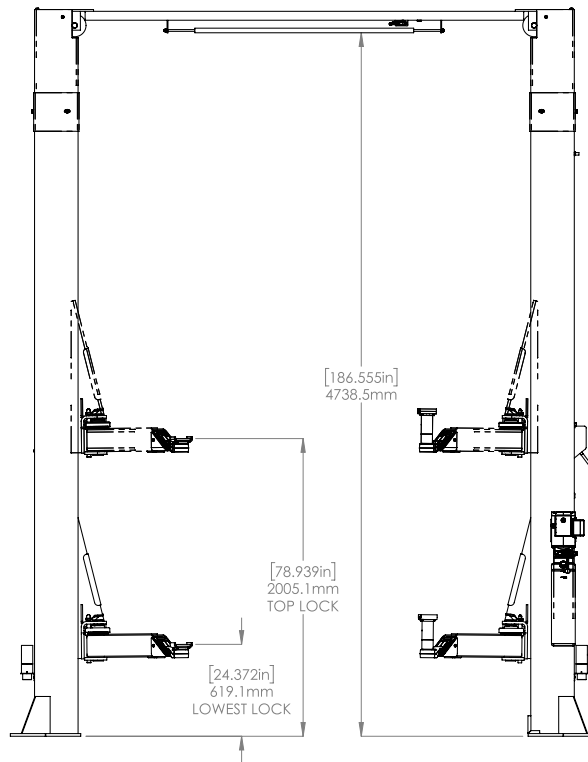

1. SAFETY LOCK POSITIONS: 15
2. SPACED EVERY: 99.0mm / 3.898"

BendPak
 1445 LEMONWOOD DR.
 SANTA PAULA, CA 93060

TITLE: **12APX-192 PRODUCTION LIFT VER A**

SIZE DWG. NO.	REV
A 5260695	F

SCALE: 1:28 SHEET 3 OF 3

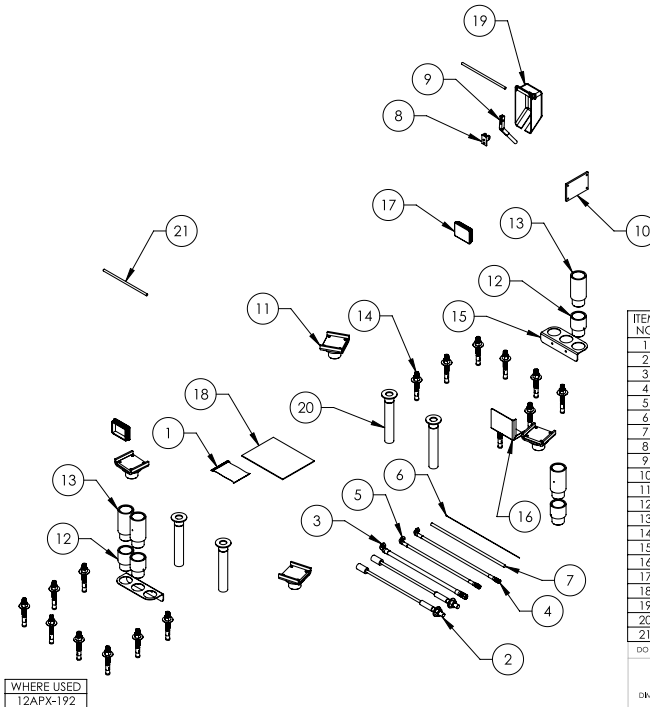

WHERE USED
12APX-192

- NOTE: UNLESS OTHERWISE SPECIFIED**
1. REFER TO MODEL FOR ADDITIONAL INFORMATION
 2. INSERT PARTS BAG INTO PARTS BOX FOR SHIPMENT
 3. HOSES AND CABLES SHOWN REPRESENTATIONAL FORM

ITEM NO	PART NUMBER	DESCRIPTION	QTY	REV
1	5174126	12APX SERIES PARTS BAG	1	C
2	5595760	CABLE ASSEMBLY Ø12 x 11660mm ST	2	B
3	5570290	HYDRAULIC HOSE ASSEMBLY Ø10 x 2790mm SB	1	B
4	5570238	HYDRAULIC HOSE ASSEMBLY Ø6.4 x 3870mm SB	1	A
5	5570255	HYDRAULIC HOSE ASSEMBLY Ø6.35 x 9168mm SB	1	B
6	5595761	SAFETY CABLE Ø1.8 x 10070mm	1	B
7	5520332	CABLE, AWG 14-2, SOCW	4772mm	-
8	5700404	AP SAFETY PIVOT HOLDER	1	C
9	5761017	AP SAFETY HANDLE	1	E
10	5715003	POWER UNIT VIBRATION DAMPENER	1	B
11	5215702	CRADLE LIFT PAD LARGE ADAPTER ASSEMBLY	4	F
12	5746192	ARM ADAPTER, MEDIUM	4	F
13	5746193	ARM ADAPTER, LONG	4	E
14	5530337	AB 3/4" x 6.3"	16	-
15	5701660	HEIGHT ADAPTER HOLDER, 60mm PIN	2	B
16	5701901	12APX FOOT GUARD	1	B
17	5715196	POLYETHYLENE COVER BLOCK 105 x 80	2	D
18	5900374	12APX INSTALLATION MANUAL	1	-
19	5716072	AP POWER SIDE PLASTIC SAFETY COVER	1	A
20	5601910	12APX/SRT ARM LOCK PIN WELDMENT, Ø44	4	B
21	5746166	DOUBLE THREADED ROD M10 x 1.5 x 295	2	B

DO NOT SCALE DRAWINGS

DRAWN CA 08/02/2022

CHECKED

DIMENSIONS ARE IN MM



NEXT ASSEMBLY
5260695

BendPak
 1445 LEMONWOOD DR.
 SANTA PAULA, CA 93060

TITLE: **12APX-192 PARTS BOX**

SIZE DWG. NO.	REV
A 5250358	D

SCALE: 1:20 SHEET 1 OF 1

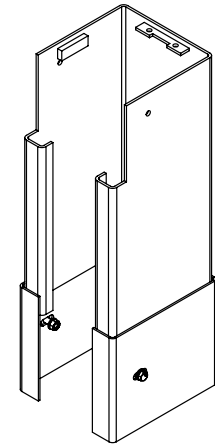
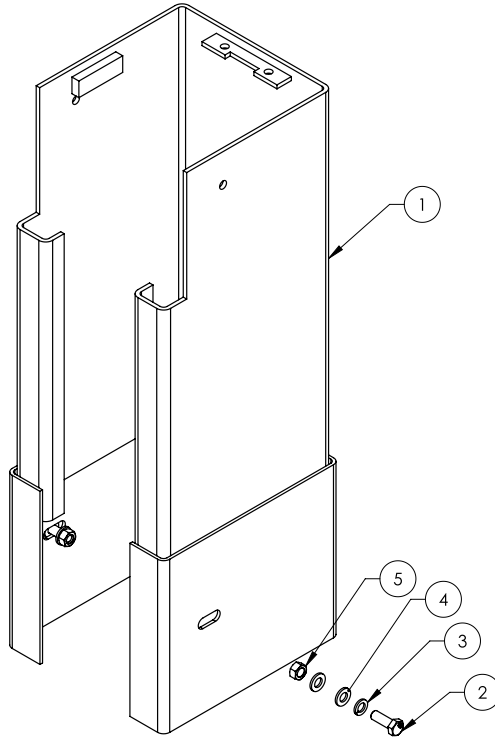

ISOMETRIC VIEW
FOR REFERENCE ONLY
DO NOT SCALE

WHERE USED
12AP-192
16AP-192
20AP-192

- NOTE: UNLESS OTHERWISE SPECIFIED .**
- REFER TO MODEL FOR ADDITIONAL INFORMATION
 - SEE SHIPPING INSTRUCTIONS FOR FINAL PACKAGING

NEXT ASSEMBLY
5240038
5240046
5260695
5260711
5260714

ITEM NO	PART NUMBER	DESCRIPTION	QTY	REV
1	5601911	12APX, 16/20AP POST EXTENSION WELDMENT	1	B
2	5530076	HHB M12 x 1.75 x 35 FT, CL 10.9	4	-
3	5545201	WASHER M12 x 21 SL, CL 10.9	4	-
4	5545347	WASHER M12 x 24 FLAT, CL 10.9	8	-
5	5535354	NUT M12 x 1.75, CL 10.9	4	-

DO NOT SCALE DRAWING	NAME	DATE	 1645 LEMONWOOD DR. SANTA PAULA, CA 93060
	DRAWN CA	07/11/2022	
	CHECKED		
DIMENSIONS ARE IN MM	THIRD ANGLE PROJECTION		TITLE: 12APX/16/20AP-192 POST EXTENSION ASSEMBLY SIZE: DWG. NO. 5216204 REV C
			PROPRIETARY AND CONFIDENTIAL THE INFORMATION CONTAINED IN THIS DRAWING IS THE SOLE PROPERTY OF BENDPAK INC. ANY REPRODUCTION IN PART OR AS A WHOLE WITHOUT THE WRITTEN PERMISSION OF BENDPAK INC. IS PROHIBITED. SCALE: 1:6 SHEET 1 OF 1

Automotive Lift Institute (ALI) Store

You probably checked the [ALI's Directory of Certified Lifts](http://www.autolift.org/ali-directory-of-certified-lifts/) before making your most recent Lift purchase, but did you know the [ALI Store](http://www.autolift.org/ali-store/) offers a variety of professional, easy-to-use, and reasonably priced training and safety materials that will make your garage a safer place to work?

The ALI Store is your trusted source for workplace safety!



Lifting It Right Online Certificate Course. Make *sure* you and your people are lifting vehicles the right way.



ALI Lift Inspector Certification Program Registration. Become a Certified Lift Inspector.

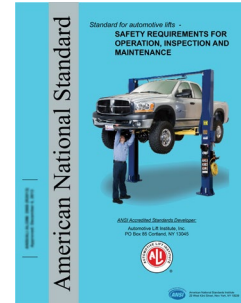

ANSI/ALI ALOIM Standard for Automotive Lifts. Safety Requirements for Operation, Inspection, and Maintenance.

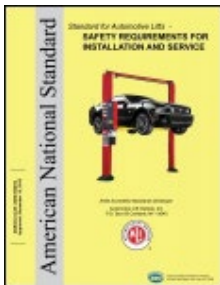

ANSI/ALI ALIS Standard. Safety Requirements for Installation and Service.

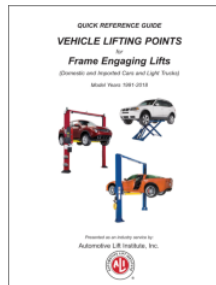

Guide to Hitting Vehicle Lifting Points for Frame-Engaging Lifts. Don't eyeball your lifting points, *know* where they are.



Lift Operator Safety Materials. Five safety documents in a single package.

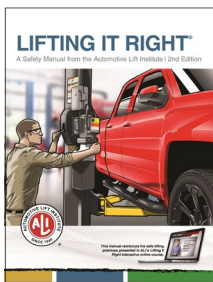

Lifting It Right. A hardcopy version of the *Lifting It Right* safety manual from the Automotive Lift Institute.



Uniform Warning Labels and Placards for 2-Posts. Labels in Mandarin, French Canadian, and Spanish are also available.



Safety Tips Card. Reminds your people of 13 key safety tips to follow daily.

Visit today and get the training and materials you need to work safely:
www.autolift.org/ali-store/.

