



---

## OWNER'S AND OPERATOR'S MANUAL

---

# Diesel Engine Generator & Welder

# DGW400DML

Vertical, Water-Cooled 4-Cycle Diesel Engine

### California Proposition 65



#### WARNING

Breathing diesel engine exhaust exposes you to chemicals known to the State of California to cause cancer and birth defects or other reproductive harm.

- Always start and operate the engine in a well ventilated area.
- If in an enclosed area, vent the exhaust to the outside.
- Do not modify or tamper with the exhaust system.
- Do not idle the engine except as necessary.

For more information go to [www.P65warnings.ca.gov/diesel](http://www.P65warnings.ca.gov/diesel).



#### WARNING

Cancer and reproductive Harm-  
[www.P65Warnings.ca.gov](http://www.P65Warnings.ca.gov)



#### WARNING

Batteries, battery posts, terminals and related accessories contain lead and lead compounds, and other chemicals known to the State of California to cause cancer and birth defects or other reproductive harm. WASH HANDS AFTER HANDLING.



#### CAUTION

Do not operate the Generator/Welder, or any other appliance, before you have read and understood the instructions for use and keep near for ready use.

DGW400DML-D2V  
X753-008 19 0  
X753803-330 1



## Introduction

We would like to thank you very much for purchasing this Shindaiwa Soundproof Diesel Engine Generator & Welder.

- This manual has been created in order to ensure safe and proper use of this equipment. Be sure to thoroughly read this manual before operating the equipment as the improper operation of this equipment can result in an accident or malfunction.
- This equipment should only be operated by persons who thoroughly understand the contents of this manual and can safely operate the equipment. Persons who are ill, taking medicine, or are in bad health should not operate this equipment if such conditions will affect operation of the equipment and related work.
- Operation and use of this equipment must be in strict compliance with the applicable laws, as well as rules and regulations based on such laws.
- Always be sure to include this manual with the equipment if it is loaned out to another party, and instruct said party that they must thoroughly read this manual before operating the equipment.
- Store this manual securely in a predetermined location so that it can be readily accessed at all times to order parts or arrange for repair. Contact the retail outlet where this equipment was purchased if any parts are lost, the equipment becomes soiled, or is otherwise damaged in any manner.
- Consult with the retail outlet where the equipment was purchased if any of the points are unclear or you would like further information. Be sure to note the model name and serial number of your equipment, and provide this information when making an inquiry.
- If disposing of this equipment, dispose in a manner according to laws and regulations applicable to industrial waste. Consult with the retail outlet where the equipment was purchased if you have any inquiries regarding proper disposal.

■ The precautions used in this manual are divided into the following three ranks.

**⚠ Danger:** Indicates an imminently hazardous situation which, if not avoided, will result in death or serious injury.

**⚠ Warning:** Improper operation can result in death or serious personal injury.

**⚠ Caution:** Improper operation can result in moderate or minor personal injury, or physical damage.

**<Note>:** Explanatory note in order to ensure that equipment protection and performance are fully realized.

- It is possible that items described under **< ⚠ Caution >** or **< Note >** can result in a serious accident depending on the circumstances. The contents of both of these types of precautions are important. Be sure to always comply with all precautions.

## Table of Contents

<b>1. Safety Precautions</b> .....	<b>2</b>
<b>2. Specifications</b> .....	<b>6</b>
<b>3. Applications</b> .....	<b>7</b>
<b>4. Part Names</b> .....	<b>7</b>
<b>5. Equipment</b> .....	<b>10</b>
5-1. Spill Containment .....	10
5-2. Idle Control.....	10
5-3. Weld Output Control.....	11
5-4. Remote Control (9-Pin Connector) .....	12
5-5. Meter .....	12
5-6. Error Code Display.....	13
5-7. Monitor Lamp .....	13
5-8. Ground Fault Circuit Interrupter (GFCI) and Grounding.....	14
5-9. Emergency Stop Switch.....	15
5-10. Wire Feeder Control.....	16
<b>6. Transporting</b> .....	<b>17</b>
<b>7. Pre-Operation Inspection</b> .....	<b>18</b>
7-1. Engine Oil Inspection .....	18
7-2. Cooling Water Inspection.....	19
7-3. Fuel Inspection.....	19
7-4. Spill Containment Inspection.....	20
7-5. Inspection for Fuel/Oil/Cooling Water Leakage .....	20
7-6. Battery Inspection .....	20
<b>8. Operating Procedures</b> .....	<b>21</b>
8-1. Starting the Engine.....	22
8-2. Stopping the Engine.....	23
8-3. Emergency Stop.....	23
<b>9. Using as a Welder</b> .....	<b>24</b>
9-1. Welding Cable Selection.....	24
9-2. Welding Polarity .....	24
9-3. Welding Cable Connection .....	25
9-4. Duty Cycle.....	26
9-5. Welding Work.....	26
<b>10. Using as a Generator</b> .....	<b>29</b>
10-1. Output Types and Ranges .....	29
10-2. Usable Device Capacities .....	29
10-3. Operation .....	30
<b>11. Simultaneously Welding and Using as AC Power Source</b> .....	<b>31</b>
<b>12. Inspection/Maintenance</b> .....	<b>32</b>
<b>13. Long-Term Storage</b> .....	<b>38</b>
<b>14. Troubleshooting</b> .....	<b>39</b>
<b>15. Engine Wiring Diagram</b> .....	<b>42</b>
<b>16. Generator Wiring Diagram</b> .....	<b>43</b>

## 1. Safety Precautions

### **⚠ Danger: Using a generator indoors CAN KILL YOU MINUTES**

- Generator exhaust contains carbon monoxide. This is a poison you cannot see or smell.
- NEVER use inside a home or garage, EVEN IF doors and windows are open.
- Only use OUTSIDE and far away from windows, doors, and vents.

### **⚠ Warning: Suffocation from Exhaust Fume**

- Do not operate the equipment in a poorly-ventilated area such as indoors or within a tunnel because the engine exhaust fume includes components that are harmful to humans.

### **⚠ Warning: Suffocation from Welding Fume**

- Always be sure to wear a fume-proof mask when welding as the fumes generated during welding include harmful gases and dust. Also be careful that the wind direction is not such that it will cause fumes to be inhaled and always operate the equipment in a well-ventilated area.

### **⚠ Warning: Electric Shock**

- Do not operate the equipment with any doors or covers open.
- Do not touch wirings or any electric parts inside the equipment during operation.
- Do not touch the equipment during operation if the equipment or your body is wet.
- Be sure to stop the engine whenever touching Weld output terminals such as when installing or removing welding cables.
- Do not connect welding cables to any part other than Weld output terminals.
- Do not insert any metallic objects, such as pins or wires, into AC output receptacles or remote control receptacles.
- Always be sure to turn off all breakers before installing or removing devices using AC output receptacles.
- Always be sure to repair the corresponding earth leakage location when earth leakage circuit breakers operate.
- Always be sure to stop the engine before performing any equipment check or maintenance.

### **⚠ Warning: Fire**

- Always be sure to stop the engine when inspecting fuel or refueling, and absolutely never perform such tasks near fire or other open flame. Wait until the engine has completely cooled before inspecting fuel or refueling.
- Always be sure to wipe up any spilled fuel or oil.
- Spilled fuel and oil accumulates in the spill containment. Do not operate the equipment with liquid accumulated in the spill containment.
- Absolutely never use the equipment if there is a fuel, oil or cooling water leak, and be sure to always repair the leak before using.
- Absolutely never inspect or perform maintenance to the equipment near fire or other open flame.
- Keep any ignitable items (such as fuel, gas and paint) or inflammable items away from the equipment because the muffler, exhaust fume and other parts attain high temperatures.

**⚠ Warning: Fire**

- Keep any ignitable items (such as fuel, gas and paint) or inflammable items away from the work area due to the scattering of weld spatter that occurs during welding.
- Provide at least 1 meter (3 feet) of distance between the equipment and walls and other obstacles, and operate the equipment on a flat surface.
- Allow the equipment to cool before covering with protective covers and similar items.
- Do not ground wiring of earth leakage circuit breakers of the equipment to piping that passes through flammable material.

**⚠ Warning: Injury**

- Do not operate the equipment with any doors or covers open. There is a danger of hair, body parts and other items being caught up in moving parts such as cooling fans and belts.
- Do not modify the equipment and do not operate with parts removed.
- Always be sure to stop the engine before performing any equipment check or maintenance.

**⚠ Warning: Injury to Eyes and Skin**

- Use protective gear, such as rubber gloves, when inspecting or replacing the battery due to the dilute sulfuric acid in the battery fluid. Be sure that fluid does not get into eyes, or on skin or clothing.
- If battery fluid gets into the eyes, or on the skin or clothing, immediately wash with a large amount of water, and always be especially sure to seek medical attention if it gets into the eyes.

**⚠ Warning: Explosion**

- Do not operate the equipment or recharge the battery when the battery fluid level is below the lower level.
- Do not generate any sparks near the battery and do not allow any fire or other open flame near the equipment because the battery generates ignitable gas.

**⚠ Warning: Electromagnetic Interference**

- Persons using a heart pacemaker are not allowed near the welder or welding work area while welding is being performed without the permission of a doctor. The welder generates a magnetic field while energized that can negatively affect pacemaker operation.

**⚠ Caution: Suffocation from Exhaust Fume**

- Do not direct the engine exhaust towards passersby, private homes or similar persons/locations because the engine exhaust fume includes components that are harmful to humans.

**⚠ Caution: Electric Shock**

- Do not sprinkle water on the equipment and do not use where exposed to rain.
- If wearing gloves, be sure to always wear gloves with dry insulation properties. Do not wear gloves that are damaged or wet.

**⚠ Caution: Burn**

- The engine, muffler and similar parts are extremely hot during operation and immediately after stopping the equipment. Never touch hot parts.
- Never open the radiator cap during operation or immediately after stopping the equipment. Hot cooling water and steam will spurt out.
- Always be sure to stop the engine and allow it to cool before inspecting or changing the engine oil. Opening the oil gauge or oil plug during operation will result in hot oil spurting out.
- Always be sure to wear leather gloves, apron, shoe covers, arc-proof glasses (face shield), safety shoes, hard hat and long-sleeve clothing to protect against the scattering of weld spatter that occurs during welding.

**⚠ Caution: Injury**

- Use this equipment with it situated on a stable level surface so that it is prevented from moving.
- Do not move the equipment during operation.
- Always be sure to turn off the switches of all devices using the equipment and turn off the equipment breakers before starting the engine.
- Always be sure to turn off the power switches of all devices using the equipment when turning on the equipment breakers. Leaving on the power switch of a device using the equipment when the equipment breakers are turned on could result in the sudden operation of the corresponding device.
- Do not leave on the power switch of a device using the equipment and do not connect a device to an AC output receptacle.
- The lifting lug is designed to be used only for lifting the equipment. Do not lift the equipment with any heavy items (such as a trailer, gas canister and additional fuel tank) added to the equipment.
- Always be sure to use the lifting lug when lifting the equipment, and lift slowly and directly straight above.
- Wear a helmet, safety shoes, gloves and similar protective gear when performing lifting work. Do not stand or get under the equipment while it is suspended.
- Securely fix the equipment with rope or similar item so that it cannot move when transporting by truck or other vehicle.

**⚠ Caution: Injury to Eyes and Skin**

- Always be sure to wear arc-proof glasses, clothes that completely cover the skin and other protective gear when welding to protect the eyes and skin from harmful light rays generated during welding.

**⚠ Caution: Physical and Secondary Damage**

- Do not use the equipment for any improper applications. Improper usage can result in an accident or malfunction.
- Do not connect the AC power source to indoor wiring.
- If using the equipment as a power source for medical equipment, you must check with the medical equipment manufacturer, doctor and hospital before using the equipment.

## ■ Location of Danger/Warning/Caution Labels

Replace danger, warning or caution labels when they become difficult to see or damaged by affixing new labels in the specified locations. Order the necessary labels by numbers in parentheses.

- (1) Suffocation from Exhaust Fume (No. X505-007590)
- (2) Suffocation from Welding Fume (No. X505-007600)
- (3) Electric Shock (No. X505-007610)
- (4) Injury (No. X505-007630)
- (5) Burn (No. X505-007620)
- (6) Fire (No. X505-007650)
- (7) Injury (No. X505-007550)
- (8) Burns (No. X505-007660)
- (9) EPA Regulation Complied Notice (No. X505-008400)
- (10) Warning / California / Operating . . . (No. X505-010400)
- (11) Warning / California / Batteries . . . (No. X505-010410)
- (12) Bonnet Grounding Terminal (No. M708-000890)
- (13) Danger: Using a generator . . . (No. X505-011430)

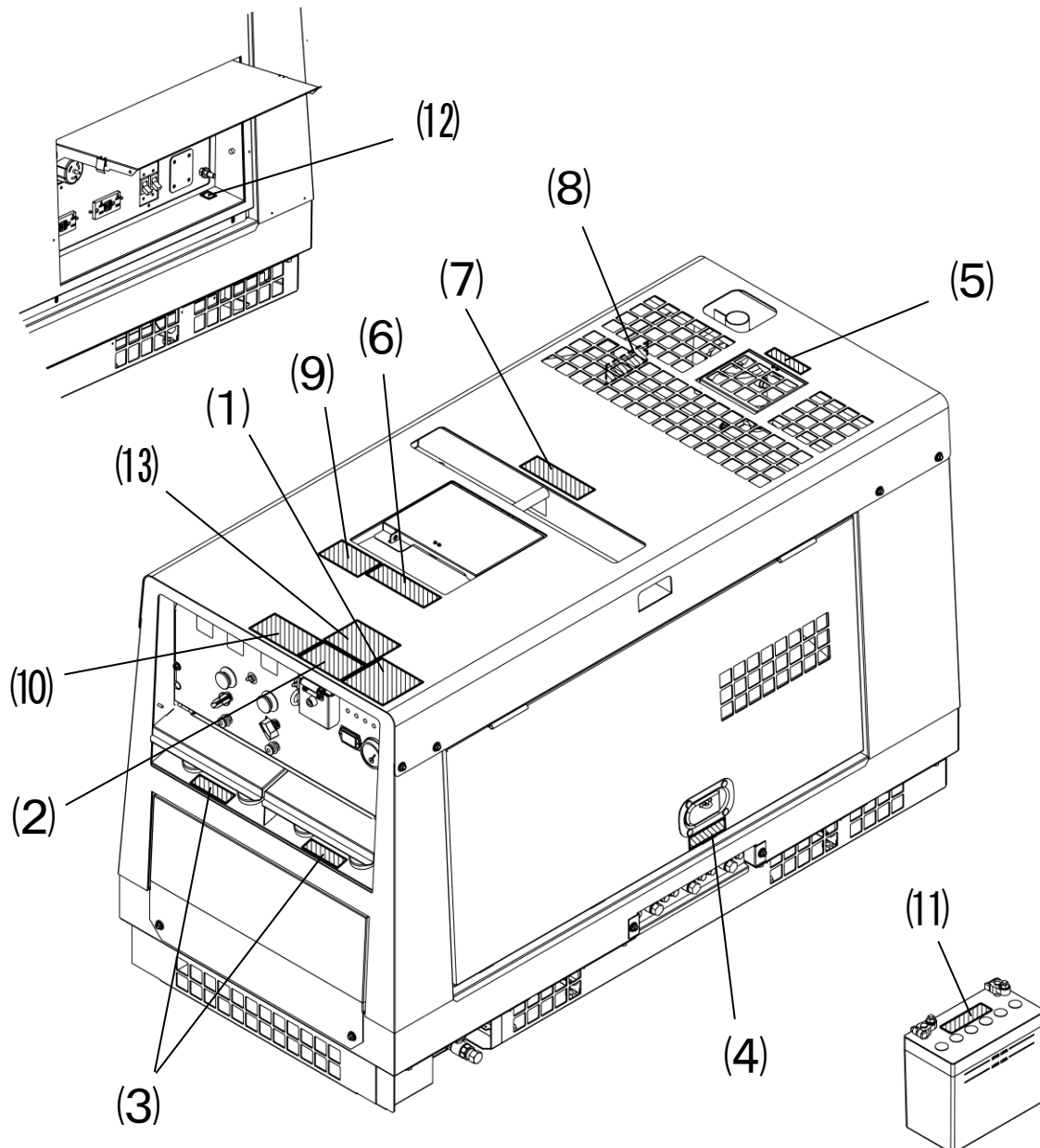

## 2. Specificaons

Model		DGW400DML-D2V		
Generating Method		Rotating Field		
Welding Generator	Operation		Single	Dual
	CC DROOP	Rated Current (A)	380	200
		Rated Voltage (V)	35.2	28.0
		Duty Cycle (%)	60	100
		Current Adj. Range (A)	30 – 390	30 – 210
		Welding Rod (in.)	5/64 – 5/16	5/64 – 5/32
		Gouging Rod (in.)	1/8 – 5/16	1/8 – 3/16
	CV	Rated Current (A)	340	200
		Rated Voltage (V)	32.0	21.0
		Duty Cycle (%)	100	100
		( Current Adj. Range (A) )	( 60 – 400 )	( 60 – 210 )
		Voltage Adj. Range (V)	14 – 35	14 – 28.5
		Welding Wire (in.)	.025 - 5/64	.025 - 1/16
Rated Speed (rpm)		3600		
No Load Voltage (V)		MAX 85		
AC Generator	Rated Frequency (Hz)		60	
	Rated Speed (rpm)		3600	
	Phase		1 Phase	3 Phase
	Rated Voltage (V)		120	120 / 240
	Rated Current (A)		20Ax2	40Ax1
	Rated Output (kVA)		4.8	4.8 / 9.6
	Power Factor		1.0	0.8
	Rating		Continuous	
Engine	Model (Manufacturer)		D902 (Kubota)	
	Type		Vertical, Water-Cooled 4-Cycle Diesel Engine	
	Displacement ( <b>cu.in.</b> / liters)		<b>55</b> / 0.898	
	Rated Output (hp / rpm)		23.6 / 3600	
	Fuel		ASTM No.2-D,S15 EPA regulation	
	Lubricant Oil		API Class CF or better (CJ excluded)	
	Fuel Tank Capacity ( <b>gal.</b> / liters)		<b>11.4</b> / 43	
	Lubrication Oil Volume ( <b>gal.</b> / liters)		<b>0.95</b> / 3.6 (Effective <b>0.45</b> / 1.7)	
	Cooling Water Volume ( <b>gal.</b> / liters)		<b>1.06</b> / 4.0 (Sub Tank Capacity <b>0.16</b> / 0.6 included)	
	Starting Motor Capacity (V - kW)		12 - 1.2	
	Charging Alternator Capacity (V - W)		12 - 150	
	Battery Capacity (V - Ah)		12 - 36 (46B24L)	
Dimen- sion	Length ( <b>in.</b> / mm)		<b>56.5</b> / 1435	
	Width ( <b>in.</b> / mm)		<b>27.6</b> / 700	
	Height ( <b>in.</b> / mm)		<b>33.4</b> / 848	
Dry Weight ( <b>lbs.</b> / kg)		<b>1045</b> / 474		
Net Weight ( <b>lbs.</b> / kg)		<b>1149</b> / 521		

### 3. Applications

- Shielded Metal Arc Welding
- Semi-automatic Arc Welding (MIG, MAG, Self-Shielded)
- Gouging
- Lift Start TIG, Scratch Start TIG
- Power Source for Light, Electric Tools and Appliances

#### **⚠ Caution: Physical and Secondary Damage**

- Do not use the equipment for any applications not listed above. Improper usage can result in an accident or malfunction.
- If using the equipment as a power source for medical equipment, you must check with the medical equipment manufacturer, doctor and hospital before using the equipment.

### 4. Part Names

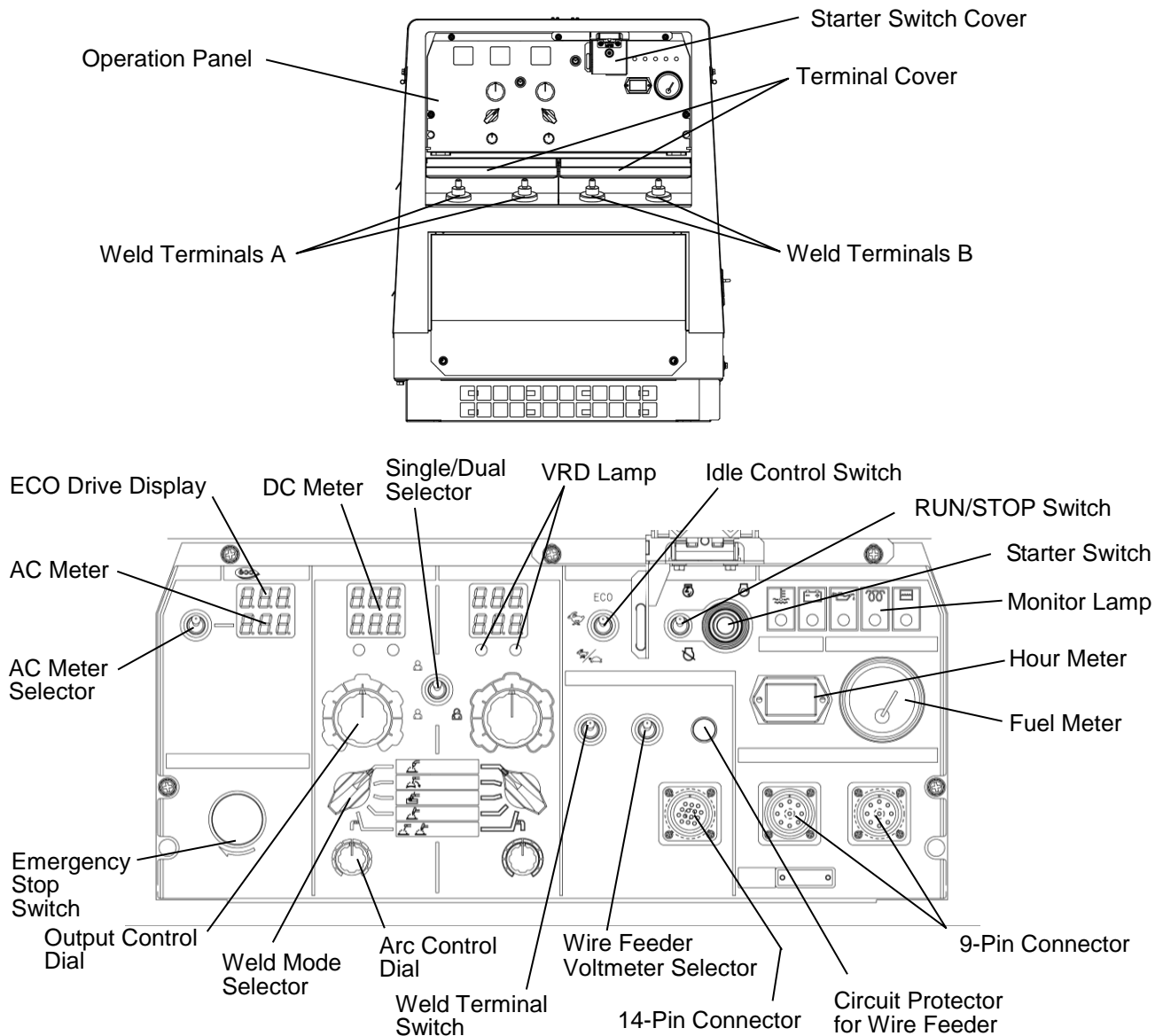

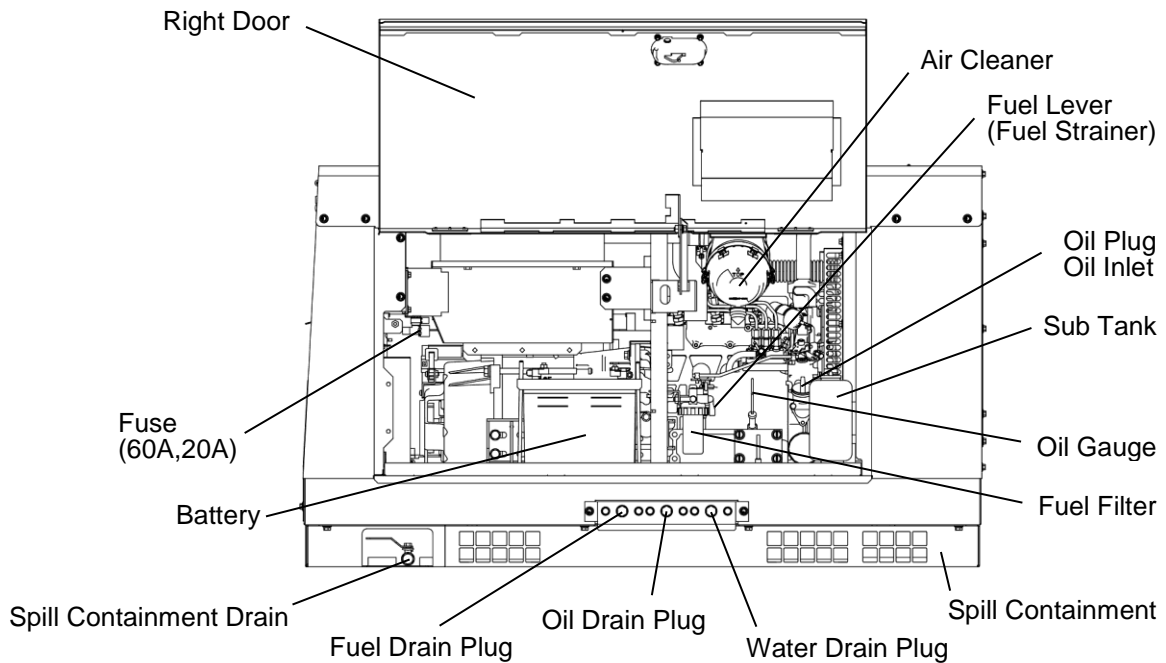
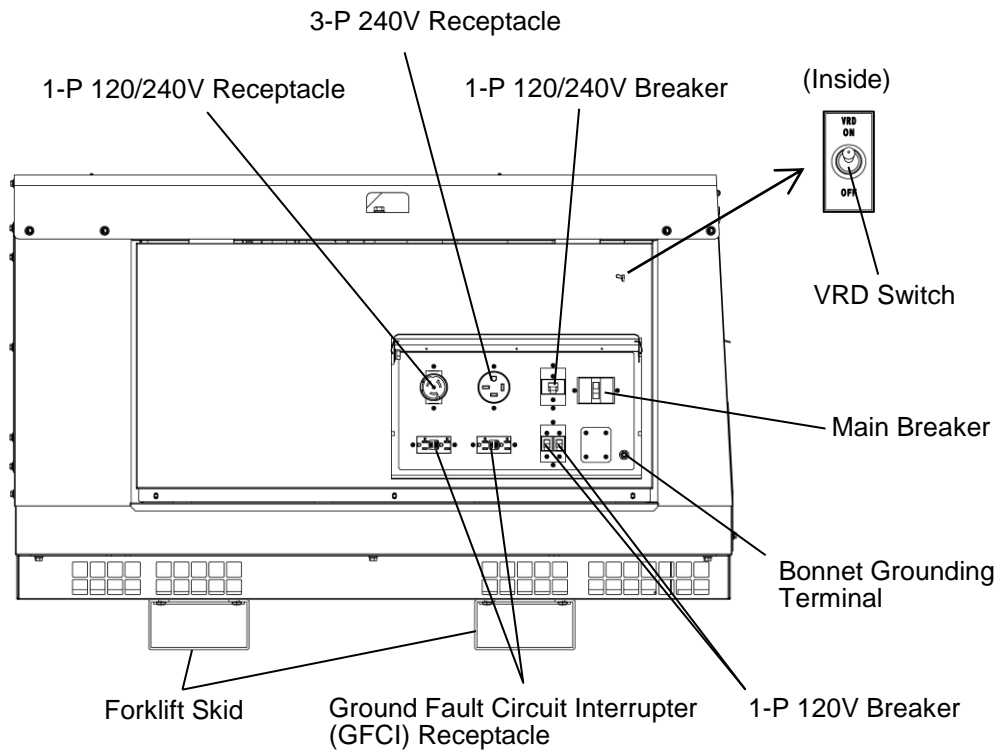

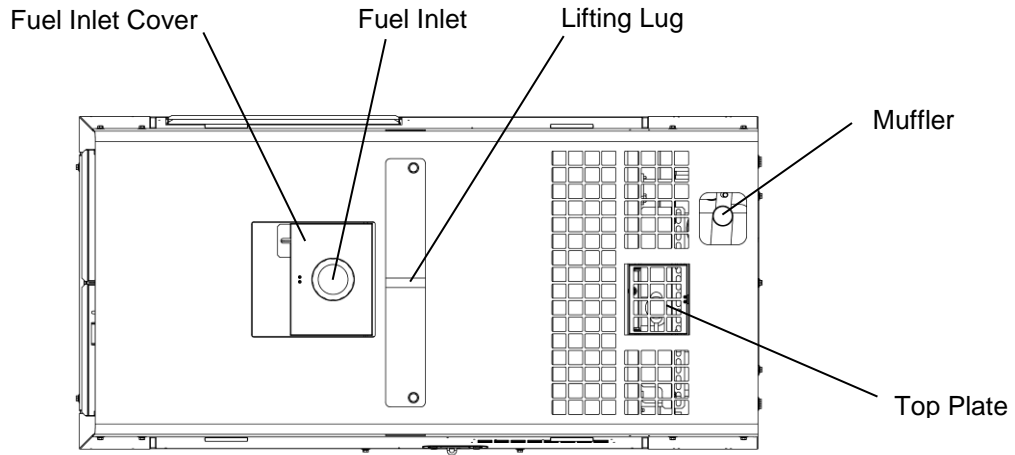

Accessories

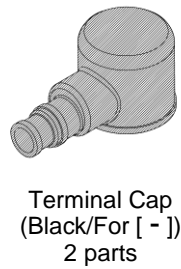
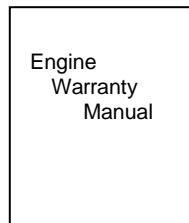
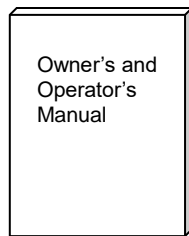

## 5. Equipment

### 5-1. Spill Containment

#### **⚠ Warning: Fire**

- Always be sure to wipe up any spilled fuel or oil.
- Spilled fuel and oil accumulates in the spill containment. Do not operate the equipment with liquid accumulated in the spill containment.
- Absolutely never use the equipment if there is a fuel, oil or cooling water leak, and be sure to always repair the leak before using.

The equipment includes a spill containment (structure that collects leaking liquid) in order to prevent leaking liquid from getting outside of the equipment if oil, fuel or other liquid should leak. Before starting operation, check if there is any fluid accumulated in the spill containment and drain any accumulated liquid. (Refer to section "12.(7) Draining Liquid from the Spill Containment".)

#### **<Note>**

- It is necessary to periodically drain the liquid from within the equipment because any rainwater that leaks into the equipment also accumulates in the spill containment.
- Although the fluids that can leak internally consist of oil, fuel and cooling water, the spill containment does not have a function that can separate rainwater that has leaked into the equipment from these internally leaked fluids. Properly dispose of liquid drained from the spill containment in a manner according to the applicable laws and regulations.

### 5-2. Idle Control

The equipment includes an idle control function. You can use the idle control switch to select an engine speed setting of "ECO", "AUTO" or "HIGH".

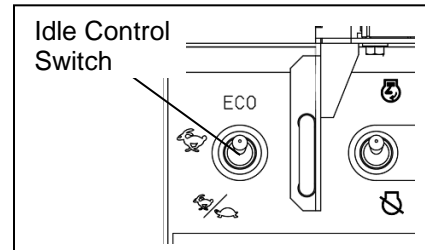

#### **(1) ECO Drive**

The equipment includes an eco drive function in order to reduce noise, save fuel, and reduce exhaust gas emission.

When the idle control switch is set to "ECO" and only welding is being performed, the engine operates at an optimal speed corresponding to the weld output and it automatically returns to low speed when welding is stopped.

The eco drive display lights up during eco drive to indicate that operation is environmentally considerate.

#### **<Note>**

- The engine speed optimization function of eco drive is only for "DROOP-STICK", "GOUGING", "LIFT START TIG" and "CC-STICK" welding. (It does not function if "CV-WIRE" is selected using the weld mode selector.)
- If using as an AC power source during eco drive (including when welding and using as an AC power source at the same time), the engine operates at high speed and the eco drive display turns off.
- Set the idle control switch to "AUTO" or "HIGH" if welding or using as an AC power source in an intermittent manner.
- Set the idle control switch to "HIGH" if using a high capacity motor, precision instruments or AC load with an attached magnetic switch.
- Set the idle control switch to "HIGH" if using as an AC power source of a device of 0.5A or less because the engine might not reach a high speed as speed control does not operate at that level.

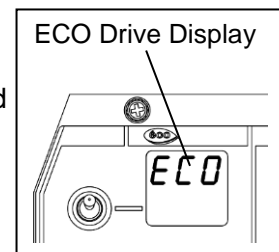

## (2) Auto Idle

The equipment includes an auto idle function in order to reduce noise, save fuel, and reduce exhaust gas emission.

You can set the idle control switch to "AUTO" so that the engine operates at low speed when not welding or using the equipment as a power source.

When you start to weld or use as an AC power source, the engine automatically increases to high speed. When in a no-load condition, the engine automatically returns to low speed after approximately 8 seconds of high-speed operation.

### <Note>

- Set the idle control switch to "HIGH" if using a high capacity motor, precision instruments or AC load with an attached magnetic switch.
- Set the idle control switch to "HIGH" if using as an AC power source of a device of 0.5A or less because the engine might not reach a high speed as speed control does not operate at that level.

## (3) High Idle

You can set the idle control switch to "HIGH" to maintain the engine constantly at high speed.

## 5-3. Weld Output Control

### (1) Weld Mode Selector

You can select a weld mode of "CV-WIRE", "DROOP-STICK", "GOUGING", "LIFT START TIG" or "CC-STICK" in accordance with the type of welding being performed.

#### ■ CV (Constant Voltage) -WIRE

You can use the equipment as a power source for semi-automatic arc welding (MIG, MAG and self-shielded).

#### ■ DROOP (Drooping Characteristic)-STICK, GOUSING

The weld current can be adjusted by manipulating the welding rod due to being able to increase or decrease the current for changing the arc length, thereby allowing you to adjust the arc status and weld beads.

The arc start is good and the arc is strongly felt.

This mode is optimal for welding work such as pipe welding or when using special welding rods.

#### ■ LIFT START TIG

The (DC) TIG welding (Lift Start) is available in this mode. The arc is generated by bringing the tungsten electrode into contact with the base material once and then lifting it up.

#### ■ CC (Constant Current) -STICK

Welding can be performed at a constant uniform current even if the arc length changes due to a shaky hand or similar cause to provide a stable arc that is not easily extinguished.

Welding can be performed at a specified current value without being affected by the length or thickness (thinness) of the welding cable.

This mode is optimal for general welding as the stable arc reduces the amount of spatter.

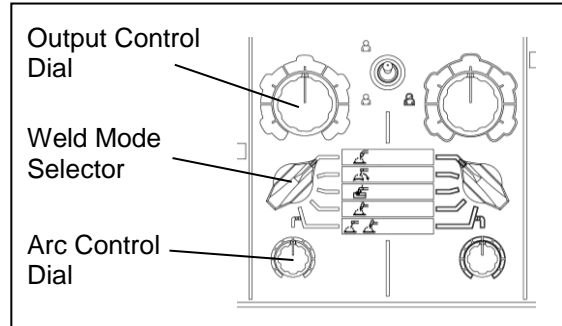

### (2) Weld Output Pre-Set

The equipment includes a weld output pre-set function.

If the weld mode selector is set to "CV-WIRE", you can pre-set the output voltage using the output control dial.

If the weld mode selector is set to "DROOP-STICK", "GOUGING", "LIFT START TIG" or "CC-STICK", you can pre-set the output current using the output control dial.

### (3) Arc Control (for CC-STICK mode)

The equipment includes an arc control function that adjusts the arc strength.

You can adjust the setting of the short-circuit current of the weld output by turning the arc control dial.

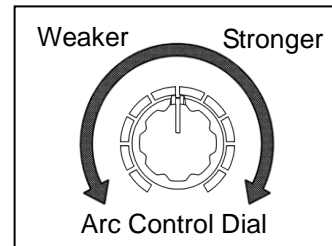

#### <Note>

- The arc control function is only for "CC-STICK" mode. It does not function if using "CV-WIRE", "DROOP-STICK", "GOUGING" or "LIFT START TIG".
- Always turn the arc control dial to "0"(zero) when the scratch start TIG welding is functioned otherwise a welding current becomes unstable as the arc control is functioned.

### 5-4. Remote Control (9-Pin Connector)

You can connect a compatible remote controller to the 9-pin connector to enable remote operation of weld output adjustment.

#### <Note>

- The output control dial for the remote control connection side of the equipment does not function when a remote controller is connected.
- If the remote controller is removed from the remote controller receptacle while welding, the equipment output control dial becomes functional, possibly resulting in a sudden increase or decrease in weld output.

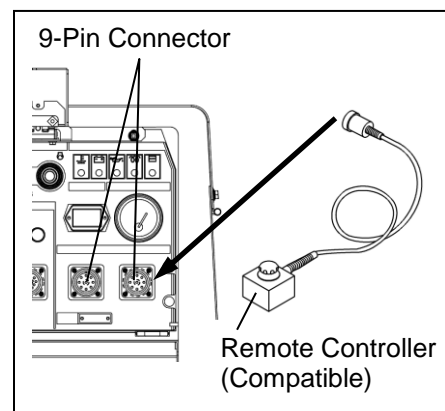

### 5-5. Meter

The equipment includes a DC meter that provides digital display of both weld current and voltage, and an AC meter that provides digital display of voltage, current and frequency of three phase 240V generated output.

#### (1) DC Ammeter – Voltmeter

The DC ammeter and voltmeter display the weld output for both outputs A and B separately.

If the single/dual selector is set to "SINGLE", the DC meter for output B does not display current or voltage.

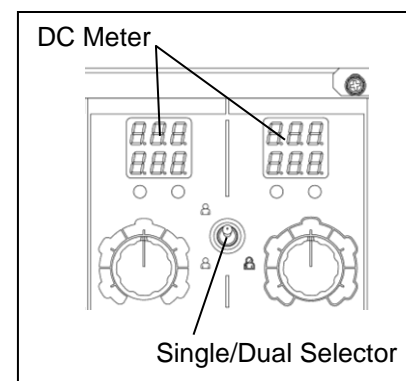

#### <Note>

- If the weld mode selector is set to "CV-WIRE", the set voltage that has been pre-set using the output control dial is displayed by the voltmeter when not welding. (The DC ammeter display is blank when not welding.)
- If the weld mode selector is set to "DROOP-STICK", "GOUGING", "LIFT START TIG" or "CC-STICK", the set current that has been pre-set using the output control dial is displayed by the DC ammeter when not welding. (The voltmeter display is blank when not welding.)
- During welding, both the DC ammeter and voltmeter display the actual output values. When welding is completed, both meters display the actual output values for approximately 8 seconds, after which display returns to the pre-set values.

## (2) AC Meter

The equipment includes an AC meter that displays the three phase 240V generated output.

The AC meter is equipped with an AC meter selector that can be switched to display voltage, current or frequency.

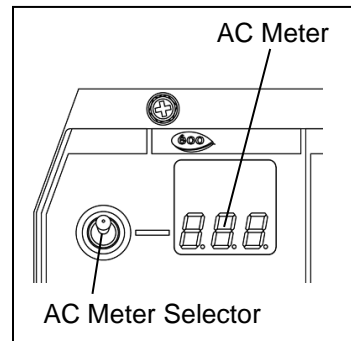

### <Note>

- During operation, the three phase 240V output voltage of the AC power source is constantly displayed regardless of whether the breaker is set to "ON" or "OFF".

## 5-6. Error Code Display

The equipment includes an error code display function that notifies the operator of any errors during operation. If an error is detected during operation, error codes are displayed by the DC and AC meters. If this occurs, stop operation immediately, and inspect and repair the location where the error has occurred.

(Refer to section "14. Troubleshooting".)

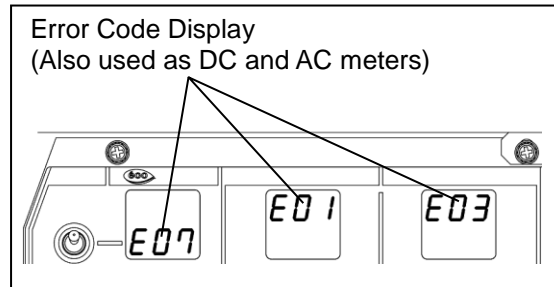

## 5-7. Monitor Lamp

### ⚠ Warning: Injury/Electric Shock

- Do not operate the equipment with any doors or covers open. There is a danger of hair, body parts and other items being caught up in moving parts such as cooling fans and belts.

### ⚠ Caution: Burn

- The engine, muffler and similar parts are extremely hot during operation and immediately after stopping the equipment. Never touch hot parts.
- Never open the radiator cap during operation or immediately after stopping the equipment. Hot cooling water and steam will spurt out.
- Always be sure to stop the engine and allow it to cool before inspecting or changing the engine oil. Opening the oil gauge or oil plug during operation will result in hot oil spurting out.

The equipment includes monitor lamps for water temperature, battery charge, oil pressure and spill containment.

If the equipment is normal, the "CHARGE", "OIL PRESS" and "PREHEAT(5 seconds)" monitor lamps light up when the RUN/STOP switch is switched to "STOP" to "RUN", and all monitor lamps turn off when the engine is started. If any error besides that of spill containment occurs during operation, the corresponding monitor lamp lights up and the engine is automatically stopped. If the engine is automatically stopped, return the starter switch to "STOP" and restart the engine. Watch the lit/unlit status of the monitor lamps the next time an automatic stop occurs and check the error contents.

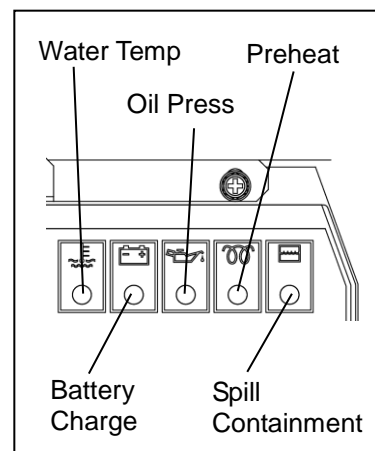

### (1) Water Temperature Monitor Lamp

The water temperature monitor lamp ("WATER TEMP") lights up and the engine is automatically stopped if the cooling water temperature becomes irregularly high during operation. If this occurs, inspect the water level of the sub tank and add cooling water if the water level is insufficient. (Refer to section "7-2 Cooling Water Inspection".)  
If the cooling water in the sub tank is at the specified level, it is probable that overloading is the cause. Use within the rated output.

### (2) Battery Charge Monitor Lamp

The battery charge monitor lamp ("CHARGE") lights up and the engine is automatically stopped if battery charge fails during operation. If this occurs, it is probable that there is fan belt damage or a wiring fault. Request repair at the retail outlet where the equipment was purchased.

### (3) Oil Pressure Monitor Lamp

The oil pressure monitor lamp ("OIL PRESS") lights up and the engine is automatically stopped if the engine oil pressure drops during operation. If this occurs, inspect the engine oil level and fill with engine oil until it reaches the maximum level.

#### <Note>

- The oil pressure monitor cannot detect oil deterioration. Change the engine oil periodically. (Refer to section "12. Inspection/Maintenance".)
- The charge monitor cannot detect battery deterioration or insufficient battery fluid. Inspect the battery fluid level periodically. (Refer to section "7-6. Battery Inspection".)
- Inspect the fuses if the engine is automatically stopped and none of the monitor lamps ("WATER TEMP", "CHARGE" and "OIL PRESS") light up. (Refer to section "4. Part Names" for fuse location.)  
If a fuse has blown, it is probable that there is a fault in an electric part or the wiring. Request repair at the retail outlet where the equipment was purchased.

### (4) Spill Containment Monitor Lamp

The spill containment monitor lamp ("SPILL CONTAINMENT") lights up if the level of liquid in the spill containment is approximately 70% full (approx. 38 L) in order to ensure that liquid accumulated in the spill containment does not spill out of the equipment. If this occurs, drain the accumulated liquid from the equipment. (Refer to section "12.(7) Draining Liquid from the Spill Containment".)

#### <Note>

- The engine is not stopped if the spill containment monitor lamp lights up during operation.
- When the spill containment monitor lamp lights up during operation, stop the engine, check for fuel, oil and cooling water leakage, and repair as necessary.
- Do not use the equipment with liquid accumulated in the spill containment. Drain the spill containment before using. (Refer to section "12.(7) Draining Liquid from the Spill Containment".)

## 5-8. Ground Fault Circuit Interrupter (GFCI) and Grounding

### **Warning: Electric Shock**

- Always be sure to repair the corresponding ground fault location when ground fault circuit interrupters operate.

### **Warning: Fire**

- Do not ground wiring of ground fault circuit interrupters of the equipment to piping that passes through flammable material.

The equipment is provided includes ground fault circuit interrupters (solidly grounded type) in order to prevent electric shock. Immediately isolate the electrical circuit if ground fault occurs due to insulation failure in devices using the equipment or similar reason.

**<Note>**

- The GFCI receptacles are protected by the ground fault circuit interrupters.

**(1) Operation Check of Ground Fault Circuit Interrupters**

Be sure to always check the ground fault circuit interrupters before starting operation according to the following procedures.

- 1) Start the engine.  
(Refer to section "8-1. Starting the Engine".)
- 2) Set the idle control switch to "HIGH".
- 3) Turn all breakers (main and 1-P 120V) to "ON".
- 4) Press the GFCI receptacle test button. Operation is normal if the GFCI receptacle reset button pop out this time.
- 5) Press the GFCI receptacle reset button until it stays in.

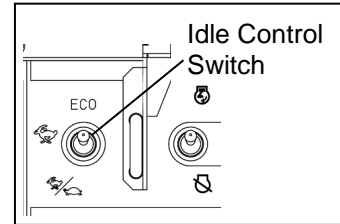

There is a fault in the ground fault circuit interrupters if operation cannot be checked according to the above procedures. Request repair at the retail outlet where the equipment was purchased.

**(2) Bonnet Grounding Terminal**

The equipment includes a bonnet grounding terminal in order to connect bonnet ground wire. A neutral point of the AC power source is connected to the bonnet grounding terminal.

**<Note>**

- Connect using a plug with a grounding pole.
- If using a plug without a grounding pole, perform grounding work and check that used devices are connected to ground.
- Securely ground the bonnet grounding terminal to the metal frame of the vehicle if transporting the equipment by truck or trailer.

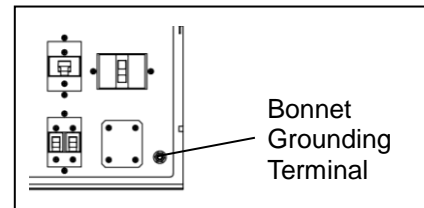
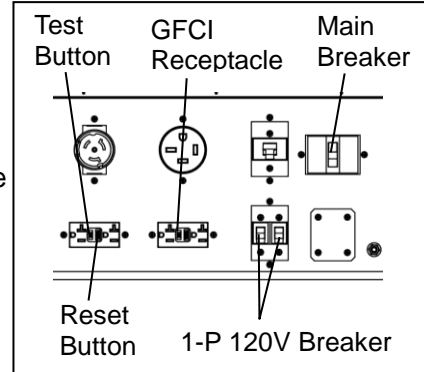

**(3) If a Ground Fault Circuit Interrupter Operates**

**⚠ Caution: Electric Shock/Injury**

- Always be sure to turn off the power switches of all devices using the equipment when turning on the equipment breakers after a ground fault circuit interrupters operates. Leaving on the power switch of a device using the equipment when the equipment breaker is turned on could result in the sudden operation of the corresponding device.

The GFCI receptacle reset button pop out when a ground fault circuit interrupters operate. When this occurs, immediately stop the engine and repair the ground fault location. After repairing all faults, press the GFCI receptacle reset button until it stays in.

**<Note>**

- There is a fault in the ground fault circuit interrupters if the GFCI receptacle LED lamp flash and reset button pop out. Request repair at the retail outlet where the equipment was purchased.

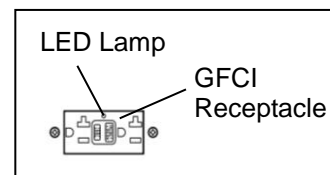

**5-9. Emergency Stop Switch**

Press the emergency stop switch to stop the engine immediately. After pressing the emergency stop switch, securely return the starter switch to the "STOP" position and turn the emergency stop switch clockwise to reset the switch.

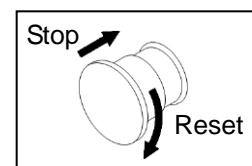

## 5-10. VRD (Voltage Reduction Device)

The equipment includes a voltage reduction device on the weld output side. The voltage reduction device reduces the output voltage of the welder when welding is paused in order to further increase safety when welding in locations with high humidity, elevated locations, extremely confined spaces near possible hazards, and similar conditions.

When the VRD switch is set to "ON" and not welding, the voltage reduction device reduces the voltage of the Weld output terminals to 35 V or less.

When welding is started, the voltage-reduction function is cancelled and the equipment returns to the reduced voltage status when welding is completed. Turning the VRD switch to "OFF" also cancels the voltage-reduction function.

The green VRD lamp ("BELOW 35V" side) lights up when weld output voltage is less than 35 V and the red lamp ("AT OR ABOVE 35V" side) lights up when the voltage is 35 V or more.

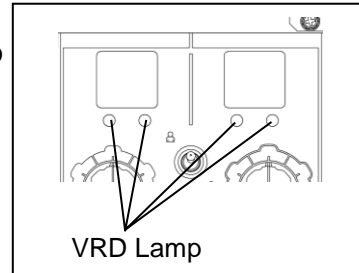
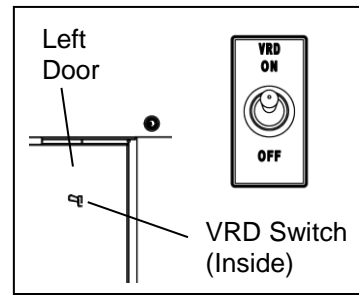

### <Note>

- The VRD is only for weld output. It does not function for AC generated output voltage.
- The VRD lamp lights up only when the VRD switch is set to "ON".
- The VRD does not function if using "CV-WIRE".

## 5-10. Wire Feeder Control

A wire feeder with a 14-pin plug can be used with this equipment.

### (1) 14-Pin Connector

Connecting the 14-pin plug of a wire feeder to the 14-pin connector of the equipment allows you to adjust the output voltage by using the wire feeder.

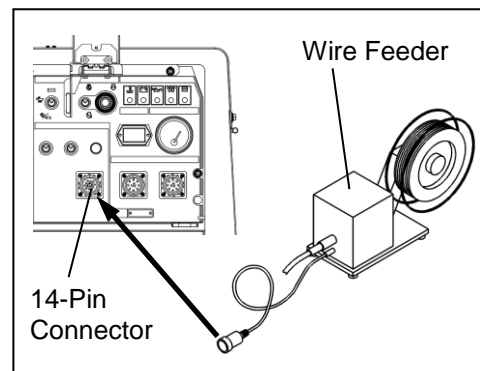

### (2) Weld Terminal Switch

Voltage is constantly output from the equipment weld terminals when the weld terminal switch is set to "WELD TERMINALS ON".

When the weld terminal switch is set to "REMOTE CONTROL", voltage is output from the equipment weld terminals only when the torch switch is set to "ON".

### (3) Wire Feeder Voltmeter Selector

By switching the wire feeder voltmeter selector, you can select the polarity of the voltmeter display equipped to the wire feeder.

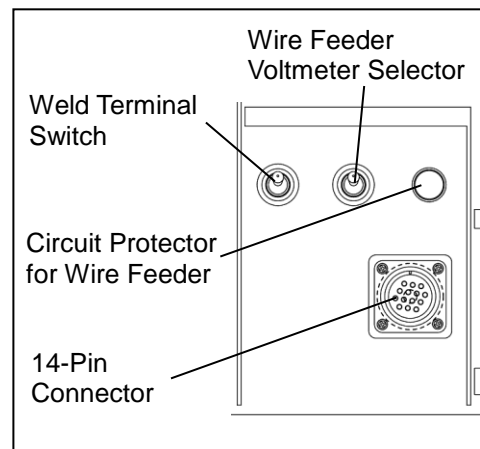

### (4) Circuit Protector for Wire Feeder

The circuit protector for the wire feeder operates to stop the current if there is an overcurrent of 5A or more in the wire feeder.

**<Note>**

- The wire feeder control function is only for output A.
- When the circuit protector for the wire feeder operates due to an overcurrent fault, inspect for the fault and press the circuit protector button after resolving the fault in order to reset the system.

## 6. Transporting

**⚠ Caution: Injury**

- Do not move the equipment during operation.
- The lifting lug is designed to be used only for lifting the equipment. Do not lift the equipment with any heavy items (such as a trailer, gas canister and additional fuel tank) added to the equipment.
- Always be sure to use the lifting lug when lifting the equipment, and lift slowly and directly straight above.
- Wear a helmet, safety shoes, gloves and similar protective gear when performing lifting work. Do not stand or get under the equipment while it is suspended.

Always be sure to fix the equipment securely when transporting the equipment.

**<Note>**

- Tighten a rope from all four-directions to protect against unintended movement when this equipment intends to transport.
- Do not hook the rope in the shoulder area on the top cover as the metal plate may become distorted if it is bent when this equipment is placed.
- Handle the equipment with great care when raising, lowering and transporting. Rough handling of the equipment can result in damage or malfunction.

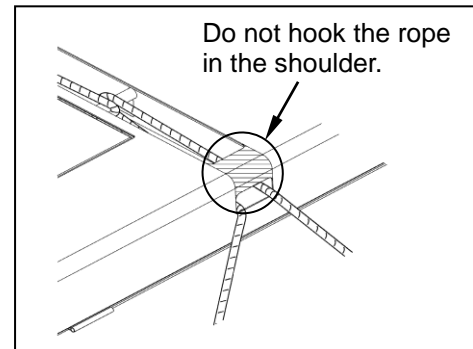
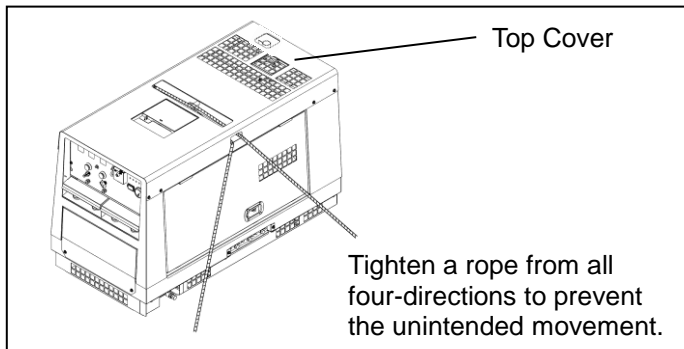

## 7. Pre-Operation Inspection

### ⚠ Warning: Injury/Electric Shock

- Do not operate the equipment with any doors or covers open. There is a danger of hair, body parts and other items being caught up in moving parts such as cooling fans and belts.
- Always be sure to stop the engine before performing any equipment check or maintenance.

### ⚠ Warning: Fire

- Always be sure to wipe up any spilled fuel or oil.
- Spilled fuel and oil accumulates in the spill containment. Do not operate the equipment with liquid accumulated in the spill containment.
- Absolutely never use the equipment if there is a fuel, oil or cooling water leak, and be sure to always repair the leak before using.
- Absolutely never inspect or perform maintenance to the equipment near fire or other open flame.

### ⚠ Caution: Burn

- The engine, muffler and similar parts are extremely hot during operation and immediately after stopping the equipment. Never touch hot parts.

### 7-1. Engine Oil Inspection

#### ⚠ Caution: Burn

- Always be sure to stop the engine and allow it to cool before inspecting or changing the engine oil. Opening the oil gauge or oil plug during operation will result in hot oil spurting out.

Situate the equipment on a level surface and completely insert the oil gauge to inspect the oil level.

Inspect the oil level before starting operation and, if it has decreased, fill with oil until it reaches the maximum level.

#### <Note>

- The oil level cannot be accurately checked if the equipment is at an angle.
- Operating the equipment when the oil has been filled above the maximum level can result in engine cylinder internal damage.

#### ■ Engine Oil Selection

Use a diesel-type engine oil with a viscosity that is appropriate for the outdoor air temperature (refer to the table).

#### <Note>

- Use oil with a quality of CF class or better (API classification / CJ excluded).

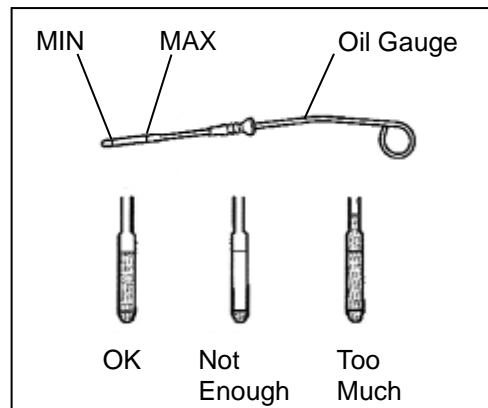
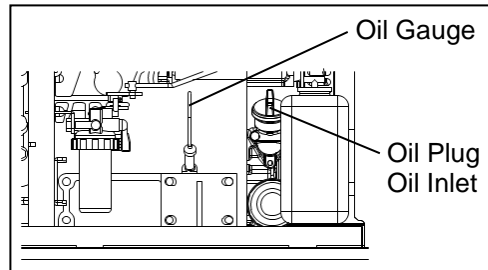

Temperature/Engine Oil Relationship

Temperature	Over +68°F	+50 to +68°F	14 to +104°F
Oil Viscosity	SAE 30	SAE 20	SAE 10W/30

## 7-2. Cooling Water Inspection

### **⚠ Caution: Burn**

- Never open the radiator cap during operation or immediately after stopping the equipment. Hot cooling water and steam will spurt out.

Check that the sub tank cooling water level is within the range of "FULL" and "LOW". If the cooling water level is lower than "LOW", add water to both the sub tank and radiator.

#### (1) Adding Water to the Sub Tank

- 1) Remove the sub tank cap.
- 2) Pour cooling water into the sub tank until it reaches the "FULL" level.
- 3) Install the sub tank cap.

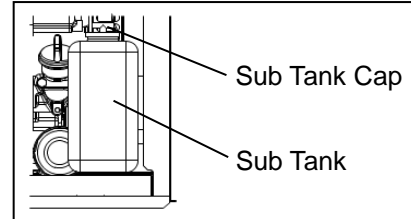

#### (2) Adding Water to the Radiator

- 1) Open the top plate.
- 2) Remove the radiator cap.
- 3) Pour cooling water into the radiator through the inlet port until it reaches the mouth of the port.
- 4) Tighten the radiator cap.
- 5) Close the top plate.

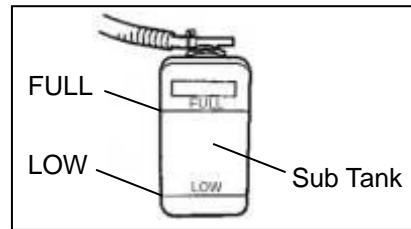

#### <Note>

- Use a long-life coolant (LLC) in order to prevent freezing and rust. (An LLC with a 50% mixing ratio is used when shipped from the factory.)
- Use an LLC mixing ratio in the range 30% to 50% in accordance with the outdoor air temperature.
- Change the LLC every 2,000 hours or 1 year.

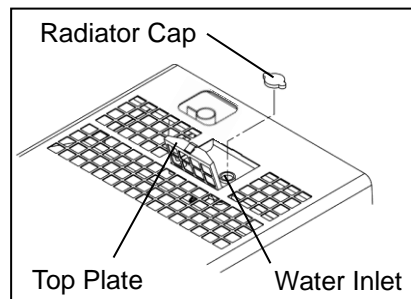

Mixing Ratio Guide

Min. Temp.	+5°F	-9°F	-31°F
Mixing Ratio	30%	40%	50%

## 7-3. Fuel Inspection

### **⚠ Warning: Fire**

- Always be sure to stop the engine when inspecting fuel or refueling, and absolutely never perform such tasks near fire or other open flame. Wait until the engine has completely cooled before inspecting fuel or refueling.

Check that there is sufficient fuel and add fuel if insufficient.

After refueling, securely tighten the tank cap and close the fuel inlet cover.

#### <Note>

- Use ASTM D975 No. 2-D, S15 diesel fuel. Do not use a substitute fuel of unknown quality as this can negatively affect the engine.
- Use a cold-weather fuel that conforms to ASTM standards if using the equipment in a cold weather region.
- Always be sure to use the fuel strainer attached to the fuel inlet.
- Add fuel until the tank is slightly less than full.

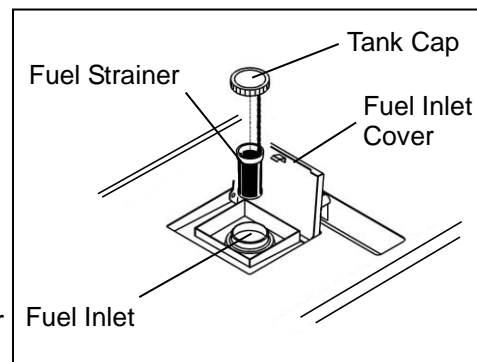

**<Note>**

Do not use any fuel other than the specified light oil type. Doing so may lead to the problems described below.

- This machine complies with the exhaust gas regulations. If you use any type of fuel other than the specified light oil type, the machine will be a product not conforming to the exhaust gas regulations.
- Using fuel mixed with heavy oil, kerosene or alcohol, or degraded fuel may have negative effect on the machine functions (a decrease in output, start-up performance deterioration) or cause the engine to malfunction (component wear and corrosion, early deterioration of the engine oil, fuel filters or fuel hoses).

#### 7-4. Spill Containment Inspection

**⚠ Warning: Fire**

- Spilled fuel and oil accumulates in the spill containment. Do not operate the equipment with liquid accumulated in the spill containment.

Open the right door, check inside of the spill containment, and drain any liquid that has accumulated. (Refer to section "12.(7) Draining Liquid from the Spill Containment".)

**<Note>**

- It is necessary to periodically drain the liquid from within the equipment because any rainwater that leaks into the equipment also accumulates in the spill containment.
- Although the fluids that can leak internally consist of oil, fuel and cooling water, the spill containment does not have a function that can separate rainwater that has leaked into the equipment from these internally leaked fluids. Properly dispose of liquid drained from the spill containment in a manner according to the applicable laws and regulations.

#### 7-5. Inspection for Fuel/Oil/Cooling Water Leakage

**⚠ Warning: Fire**

- Absolutely never use the equipment if there is a fuel, oil or cooling water leak, and be sure to always repair the leak before using.

Open the right door and check for fuel leakage from fuel line joints and similar components, and check for oil and cooling water leakage. Open the fuel tap to perform inspection and close it after inspection has been completed.

#### 7-6. Battery Inspection

##### California Proposition 65

**⚠ WARNING**

Batteries, battery posts, terminals and related accessories contain lead and lead compounds, and other chemicals known to the State of California to cause cancer and birth defects or other reproductive harm. WASH HANDS AFTER HANDLING.

**⚠ Warning: Injury to Eyes and Skin**

- Use protective gear, such as rubber gloves, when inspecting or replacing the battery due to the dilute sulfuric acid in the battery fluid. Be sure that fluid does not get into eyes, or on skin or clothing.
- If battery fluid gets into the eyes, or on the skin or clothing, immediately wash with a large amount of water, and always be especially sure to seek medical attention if it gets into the eyes.

**⚠ Warning: Explosion**

- Do not operate the equipment or recharge the battery when the battery fluid level is below the lower level.
- Do not generate any sparks near the battery and do not allow any fire or other open flame near the equipment because the battery generates ignitable gas.

- 1) Inspect the battery fluid level. If it is near the lower level, add distilled water until it reaches the upper level.
- 2) Inspect for loose terminals and retighten if loose.

**<Note>**

- It is necessary to recharge the battery when the specific gravity of the battery fluid is 1.23 or less. Contact the retail outlet where the equipment was purchased if this occurs.

**■ Battery Replacement Procedures**

- 1) Remove the " - " (negative) cable.  
(Always be sure to first remove the " - " (negative) side.)
- 2) Remove the battery hold-down clamp.
- 3) Remove the "+" (positive) cable.
- 4) Remove the battery.

- \* Install the battery by performing the above procedures in reverse order.  
(Always be sure to first attach the "+" (positive) side.)

**<Note>**

- Use the specified battery. < 46B24L > (Japanese Industrial Standard)

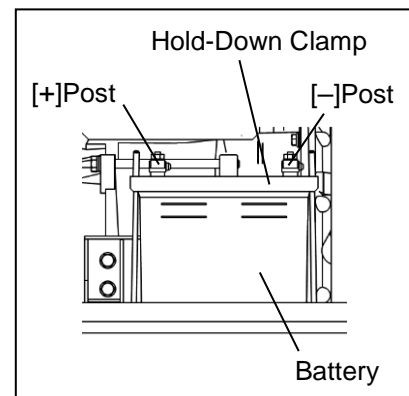
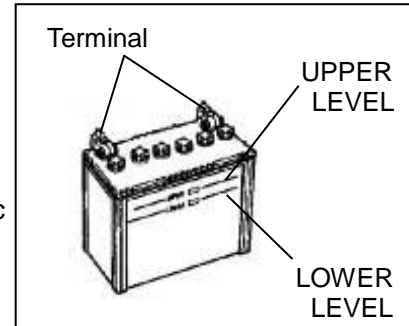

## 8. Operating Procedures

**⚠ Warning: Suffocation from Exhaust Fume**

- Do not operate the equipment in a poorly-ventilated area such as indoors or within a tunnel because the engine exhaust fume includes components that are harmful to humans.

**⚠ Warning: Fire**

- Keep any ignitable items (such as fuel, gas and paint) or inflammable items away from the equipment because the muffler, exhaust fume and other parts attain high temperatures.
- Provide at least 1 meter (3 feet) of distance between the equipment and walls and other obstacles, and operate the equipment on a flat surface.

**⚠ Caution: Suffocation from Exhaust Fume**

- Do not direct the engine exhaust towards passersby, private homes or similar persons/locations because the engine exhaust fume includes components that are harmful to humans.

**⚠ Caution: Burn**

- The engine, muffler and similar parts are extremely hot during operation and immediately after stopping the equipment. Never touch hot parts.

**⚠ Caution: Injury**

- Use this equipment with it situated on a stable level surface so that it is prevented from moving.
- Do not move the equipment during operation.
- Always be sure to turn off the switches of all devices using the equipment and turn off the equipment breakers before starting the engine.

**<Note>**

- Check that the surrounding area is safe before starting the engine.
- When there are multiple workers who are working together, they must mutually signal each other before starting the engine.
- Do not use in an area with high temperature or humidity, or an area with a large amount of dust.
- Do not open any doors during operation. Operating with a door open can negatively affect cooling effect, resulting in an equipment malfunction.
- Use ear protection if the level of noise is high. Failure to do so could result in hearing damage.

**8-1. Starting the Engine**

- 1) Turn all breakers (Main, 1-P 120/240V and 1-P 120V) to "OFF".
- 2) Turn the fuel lever (on the fuel strainer) to "OPEN".
- 3) Set the idle control switch to "ECO" or "AUTO".
- 4) Check that the emergency stop switch has been released.
- 5) If the temperature is 41°F or less, Set the RUN/STOP switch to the "RUN" position and wait until the preheat lamp turns off. (approx. 5 seconds)
- 6) Push the starter switch to start the starter motor, which then starts the engine.
- 7) After the engine starts, remove your hand from the starter switch.
- 8) Allow the engine to warm up for approximately 5 minutes.

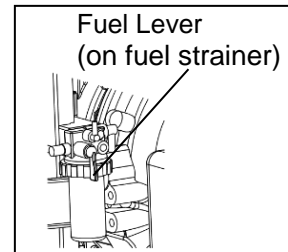
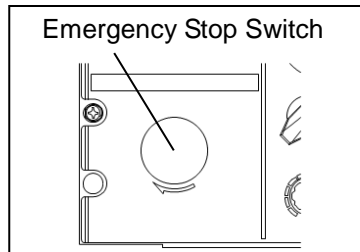
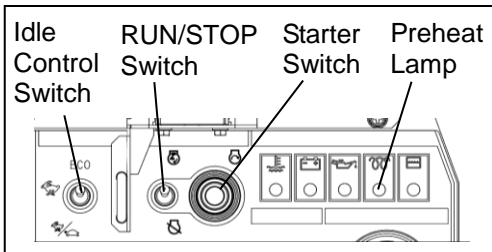
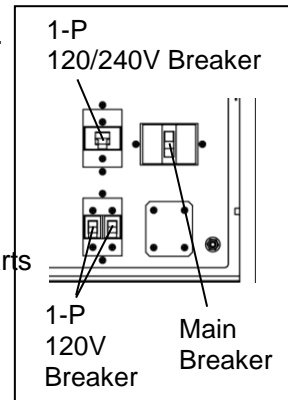

**<Note>**

- Do not crank the starter motor for 15 seconds or more continuously.
- If repeating starter switch operation, wait 30 seconds or more between operations.

■ **Restarting after Stopping due to Running Out of Fuel**

The equipment includes an automatic air-bleeding device. You can easily restart the engine according to the following procedures even if the engine stops due to running out of fuel.

- 1) Turn all breakers (Main, 1-P 120/240V and 1-P 120V) to "OFF".
- 2) Turn the RUN/STOP switch to the "STOP" position.
- 3) Add fuel to the fuel tank.
- 4) Set the idle control switch to "ECO" or "AUTO".
- 5) Turn the RUN/STOP switch to the "RUN" position and push the starter switch to crank the starter motor for approximately 10 seconds.
- 6) After the engine starts, remove your hand from the starter switch.
- 7) Wait for air to be completely bled from the fuel pipes and engine speed to stabilize (approx. 1 minute).  
\*Engine speed is not stable until all air is bled from the fuel pipes.

**<Note>**

- Do not switch the engine to high speed or apply any loads to it until all the air has been bled from the fuel pipes (until speed is stable). Doing so can cause a malfunction.

**8-2. Stopping the Engine**

- 1) Turn all breakers (Main, 1-P 120/240V and 1-P 120V) to "OFF".
- 2) Set the idle control switch to "ECO" or "AUTO".
- 3) Allow the engine to cool down for approximately 5 minutes.
- 4) Set the RUN/STOP switch to "STOP".
- 5) After the engine stops, turn the fuel lever to "CLOSE".

**<Note>**

- Do not stop the engine while welding or using as an AC power source. Doing so can cause a malfunction.
- If the engine does not stop when the RUN/STOP switch is set to "STOP", turn the fuel lever to "CLOSE". The engine will stop a few minutes afterwards. If the engine does not stop by RUN/STOP switch operation, stop using the equipment and request repair at the retail outlet where the equipment was purchased.

**8-3. Emergency Stop**

The equipment includes an emergency stop device.

Press the emergency stop switch if you want to immediately stop the engine when an emergency occurs in the work area, the equipment suffers an operating fault, and similar circumstances.

**<Note>**

- After stopping the engine using the emergency stop device, turn the RUN/STOP switch to "STOP".
- Do not strike the emergency stop switch with a hammer or similar tool.
- Only use the emergency stop switch for emergency stop purposes.
- If the engine does not stop when the emergency stop switch is pressed, turn the fuel lever to "CLOSE". The engine will stop a few minutes afterwards.

## 9. Using as a Welder

### 9-1. Welding Cable Selection

Use welding cables with a cross-sectional area that is larger than the proper cross-sectional areas indicated in the table below.

Using cable that is less than the proper cross-sectional area reduces the weld output.

**<Note>**

- Use welding cables when they are completely extended (not coiled). Using a cable that is coiled reduces the weld output.

Proper Cable Cross-Sectional Area (Units: mm<sup>2</sup>)

Return Length \ Weld Current	20m	30m	40m	60m	80m	100m
400A	38	50	60	100	125	200
350A	30	50	60	80	125	150
300A	30	38	50	80	100	125
250A	22	30	38	60	80	100
200A	22	30	30	50	60	80
150A	22	22	22	38	50	60
100A	22	22	22	30	30	38

### 9-2. Welding Polarity

There are "+" (positive) and "-" (negative) weld output terminals.

Refer to the table below to select a polarity corresponding to the work you are performing.

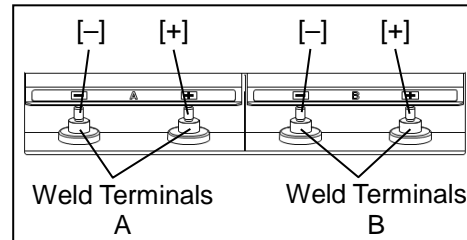

**<Note>**

- Use the polarity indicated for the welding rods being used if so indicated.
- When welding with 2 persons using different polarities for the same base material, a single worker must not hold 2 holders because the voltage between the 2 holders could become high and there may be a danger.

#### (1) Shielded Metal Arc Welding, Gouging, Lift Start TIG, Scratch Start TIG

Polarity	Rod Indication	Applications	Connecting Method
Straight Polarity	DC-	<ul style="list-style-type: none"> <li>• Shielded metal arc welding of structures and similar items</li> <li>• Lift Start TIG Welding</li> <li>• Scratch Start TIG Welding</li> </ul>	+ (positive) terminal : Earth (Base material) - (negative) terminal : Holder (welding rod)
Reverse Polarity	DC+	<ul style="list-style-type: none"> <li>• Shielded metal arc welding of laminates, weld overlays, stainless steel and similar materials</li> <li>• Gouging</li> </ul>	+ (positive) terminal : Holder (welding rod) - (negative) terminal : Earth (Base material)

## (2) Semi-automatic Arc Welding (MIG, MAG, Self-shielded)

Polarity	Wire Indication	Applications	Connecting Method
Straight Polarity	DC-	<ul style="list-style-type: none"> <li>Self-shielded Arc Welding</li> </ul>	+ (positive) terminal : Earth (Base material) - (negative) terminal : Torch (wire)
Reverse Polarity	DC+	<ul style="list-style-type: none"> <li>MIG Welding, MAG Welding</li> <li>Self-shielded Arc Welding</li> </ul>	+ (positive) terminal : Torch (wire) - (negative) terminal : Earth (Base material)

### 9-3. Welding Cable Connection

#### **⚠ Warning: Electric Shock**

- Be sure to stop the engine whenever touching Weld output terminals such as when installing or removing welding cables.

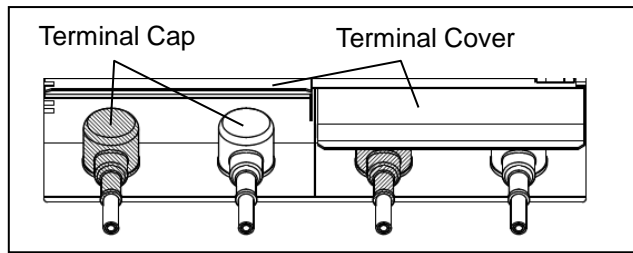
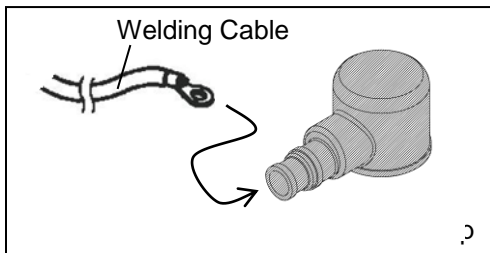
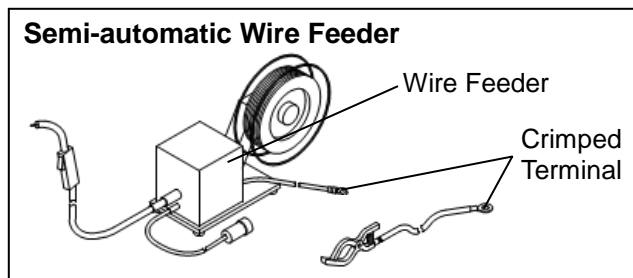
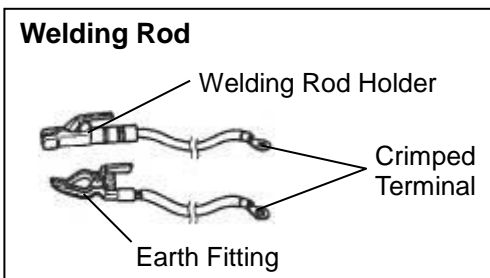

- 1) Stop the engine.
- 2) Install the welding cables, crimped terminals, welding rod holders (or wire feeder) and earth fittings.
- 3) Pass the welding cables through the terminal caps.
- 4) Connect the welding cables to the weld terminals and cover with the terminal caps. (Refer to the following table explaining the welding cable connection locations.)
- 5) Close the terminal covers.

Amount of Welding Personnel and Welding Cable Connection Locations

Shielded Metal Arc Welding / Gouging		Semi-automatic Arc Welding	
Single	Dual	Single	Dual
Welding Rod(in.) 5/64 – 5/16	Welding Rod(in.) 5/64 – 5/32	Welding Wire (in.)	Welding Wire (in.)
Gouging Rod(in.) 1/8 – 5/16	Gouging Rod(in.) 1/8 – 3/16	MIG/MAG : .025 – .045 Self-shielded : .035 – 5/64	MIG/MAG : .025 – .040 Self-shielded : .035 – 1/16
Weld Terminals A	Weld Terminals A or B	Weld Terminals A	Weld Terminals A or B

**<Note>**

- Securely crimp the crimped terminals and securely connect the welding cables. Using insufficiently crimped terminals or loosely connected cables can result in heat generation from poor connection, thereby causing burnout of the weld output terminals. Also do not use iron washers, etc., as it may cause heat generation.
- Be sure to always securely crimp the crimped terminals on the cables connected to the Weld output terminals. Not using crimped terminals and simply wrapping stripped cable around the weld output terminal can result in heat generation from poor connection, thereby causing burnout of the weld output terminals and a short circuit due to contact of the cable core with the equipment body.
- Keep your welding cable and electrode holder in good condition. Repair or replace any damaged insulation.

**9-4. Duty Cycle**

The duty cycle is the percentage of time the load is being applied in a 10-minute period. For example a 60% duty cycle, represents 6 minutes of load and 4 minutes of no-load in a 10-minute period.

**<Note>**

- Continuing to weld beyond the rated duty cycle with the rated output can result in equipment overheating and corresponding malfunctions.

**9-5. Welding Work**

**⚠ Warning: Suffocation from Welding Fume**

- Always be sure to wear a fume-proof mask when welding as the fumes generated during welding include harmful gases and dust. Also be careful that the wind direction is not such that it will cause fumes to be inhaled and always operate the equipment in a well-ventilated area.

**⚠ Warning: Fire**

- Keep any ignitable items (such as fuel, gas and paint) or inflammable items away from the work area due to the scattering of weld spatter that occurs during welding.

**⚠ Warning: Electromagnetic Interference**

- Persons using a heart pacemaker are not allowed near the welder or welding work area while welding is being performed without the permission of a doctor. The welder generates a magnetic field while energized that can negatively affect pacemaker operation.

**⚠ Caution: Burn**

- Always be sure to wear leather gloves, apron, shoe covers, arc-proof glasses (face shield), safety shoes, hard hat and long-sleeve clothing to protect against the scattering of weld spatter that occurs during welding.

**⚠ Caution: Injury to Eyes and Skin**

- Always be sure to wear arc-proof glasses (refer to the table below), clothes that completely cover the skin and other protective gear when welding to protect the eyes and skin from harmful light rays generated during welding.

Standards for Arc-Proof Glasses (Japanese Industrial Standard)

Filter No.		7	8	9	10	11	12	13	14
Weld Current (A)	Shielded metal arc welding	35-75		76-200		201-400		400-	
	Gas-shielded arc welding	---	---	100 or less		101-300		301-500	
	Gouging	---	---	---	126-225		226-350		---

**⚠ Caution: Electric Shock**

- If wearing gloves, be sure to always wear gloves with dry insulation properties. Do not wear gloves that are damaged or wet.

You can select from among five weld modes in accordance with the type of welding being performed. Select a weld mode by referring to the recommended modes in the table below.

Weld Modes Table (Recommended)

Mode Name	Applications	Welding Position
CV-WIRE	•Semi-automatic Arc Welding (MIG, MAG, self-shielded, and similar welding)	All directions
DROOP-STICK	•Welding of pipes, tanks and similar items	Vertical and Upward
GOUGING	•Gouging	
LIFT START TIG	•(DC) TIG welding	Horizontal and Downward
CC-STICK SCRATCH START TIG	•Welding of structures and finishing welding •Welding of heavy structures and thick plates •(DC) TIG welding	

**<Note>**

- This equipment allows for 2-person simultaneous welding. For 2-person simultaneous welding, select a weld mode and adjust the weld output in accordance with each type of welding work being performed.
- The range of weld output that can be adjusted using the output control dial varies depending on the positions of the single/dual selector, weld mode selector. (Refer to section "2. Specifications".)

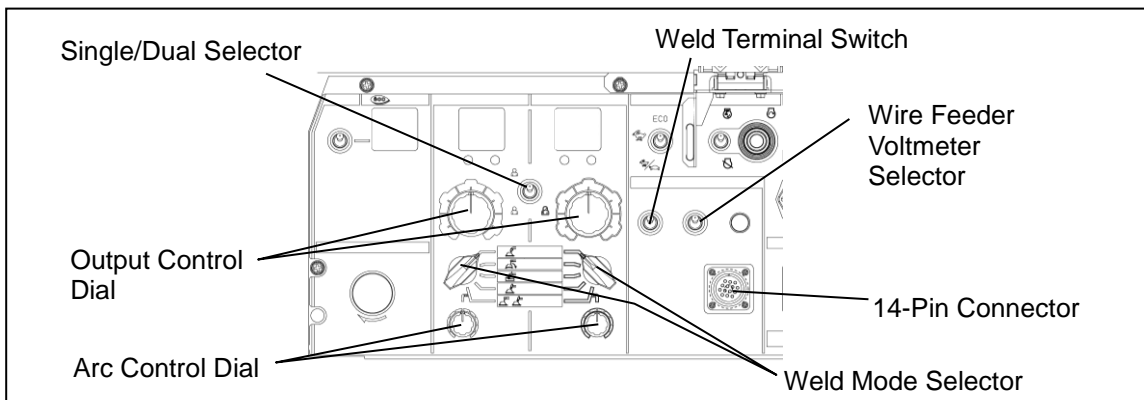

## Semi-automatic Arc Welding

### ■ Not Using a 14-Pin Connector

- 1) Set the weld mode selector to "CV-WIRE".
- 2) Switch the single/dual selector in accordance with the amount of welding personnel and desired weld output.
- 3) Set the weld terminal switch to "WELD TERMINALS ON".
- 4) Set the output control dial to the desired voltage.
- 5) Start the engine. (Refer to section "8-1. Starting the Engine".)
- 6) Set the wire feed speed of the wire feeder.
- 7) While an arc is being generated, adjust the output control dial of the equipment or remote controller so that the arc is stabilized.

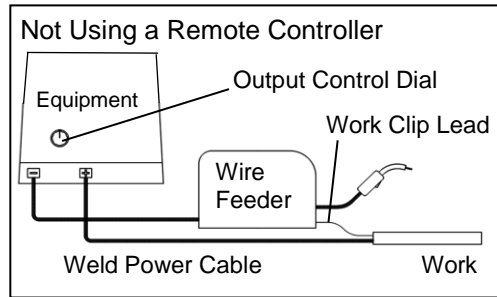

### ■ Using a 14-Pin Connector

- 1) Connect the 14-pin plug of the wire feeder to the 14-pin connector of the equipment.
- 2) Set the weld mode selector to "CV-WIRE".
- 3) Switch the single/dual selector in accordance with the amount of welding personnel and desired weld output.
- 4) Set the weld terminal switch to "REMOTE CONTROL".
- 5) Switch the wire feeder voltmeter selector in accordance with the polarity of the voltmeter indication of the connected wire feeder.
- 6) Start the engine. (Refer to section "8-1. Starting the Engine".)
- 7) Set the wire feed speed of the wire feeder.
- 8) While an arc is being generated, adjust the output control dial of the wire feeder so that the arc is stabilized.

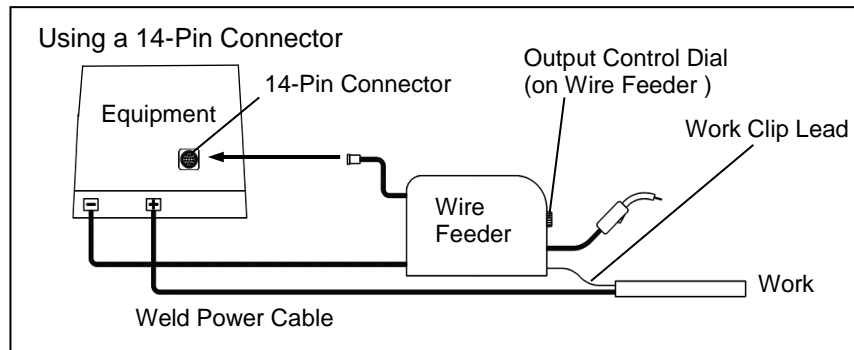
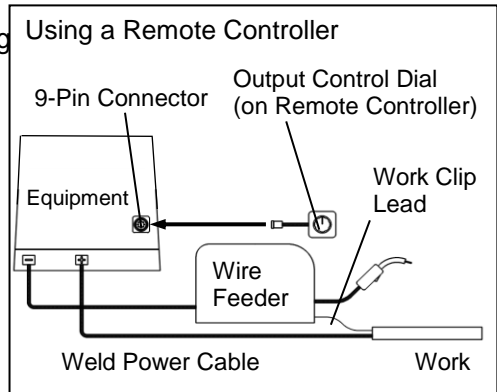

### (1) Shielded Metal Arc Welding, Gouging, Lift Start TIG, Scratch Start TIG

- 1) Set the weld terminal switch to "WELD TERMINALS ON".
- 2) Switch the single/dual selector in accordance with the amount of welding personnel and desired weld output.
- 3) Switch the weld mode selector in accordance with the work being performed.
- 4) Adjust the output current using the output control dial.
- 5) If using "CC-STICK" weld mode, adjust the arc strength using the arc control dial.

#### <Note>

- The value selected using the output control dial is displayed by the DC meter. During welding, both the DC ammeter and voltmeter display the actual output values. When welding is completed, both meters display the actual output values for approximately 8 seconds, after which display returns to the set values.
- The arc control function is only for "CC-STICK" mode. It does not function if using "CV-WIRE", "DROOP-STICK", "GOUGING" or "LIFT START TIG".

## 10. Using as a Generator

### 10-1. Output Types and Ranges

#### (1) 3-Phase 240V

The equipment includes one 3-phase 240V receptacle.

The total maximum output available from the receptacle is 15kVA.

#### (2) 1-Phase 120/240V

The equipment includes one 1-phase 120/240V receptacle.

The total maximum output available from the receptacles is 4.8/9.6kVA.

#### (3) 1-Phase 120V (GFCI)

The equipment includes two 1-phase 120/240V receptacles.

The total maximum output available from the four (2 set) receptacles is 4.8kVA.

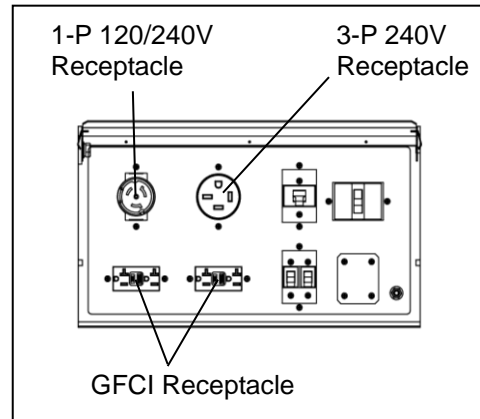

#### <Note>

- If using 3-Phase output with a 1-Phase 120/240V output simultaneously, use in a range of total current, not exceed from the maximum rated output (12kW).
- If using 3-Phase output with a 1-Phase 120/240V output simultaneously, be careful as it is possible for the outputs to mutually affect each other.

### 10-2. Usable Device Capacities

Usable capacity varies depending on the type and performance of the electrical tool or household appliance being used.

Overview of Usable Device Capacities

Device Used	Standard Capacities (Units: kW)			
	1-Phase 120V		1-Phase 120/240V	3-Phase 240V
	Capacity per one receptacle	Total capacity	Capacity receptacle	Capacity receptacle
Incandescent bulbs, electrical heaters and similar devices	1.2	4.8	4.8 / 9.6	---
Electrical tools (commutator motor) and similar devices	0.6	2.4	2.4 / 4.8	---
Mercury lamps (high power factor types)	0.5	1.9	1.9 / 3.8	---
Submerged pump, compressor and similar devices (Induction motors)	0.5	1.9	1.9 / 3.8	4.8

\* Commutator motors: Motors with brushes

\* Induction motors: Motors without brushes

\* Capacity values are displayed under "OUTPUT" for induction motors and under "POWER CONSUMPTION" for all other devices.

**<Note>**

- This equipment is a 60Hz dedicated unit. Use 60Hz devices with this equipment.
- Devices using a motor might require power that is larger than the device rating. In such cases, consult with the retail outlet where the equipment was purchased.
- Do not start up multiple devices simultaneously if using two or more units of devices such as submerged pumps. Start each unit separately.
- Do not light up a mercury lamp again immediately after turning it off. Wait for the lamp to cool down (approximately 15 minutes) after a lamp has been turned off before turning it on again.

**10-3. Operation**

**⚠ Warning: Electric Shock**

- Always be sure to turn off all breakers before installing or removing devices using AC output receptacles.
- Always be sure to repair the corresponding earth leakage location when earth leakage circuit breakers operate.

**⚠ Caution: Injury**

- Always be sure to turn off the power switches of all devices using the equipment when turning on the equipment breakers. Leaving on the power switch of a device using the equipment when the equipment breakers are turned on could result in the sudden operation of the corresponding device.
- Do not leave on the power switch of a device using the equipment and do not connect a device to an AC output receptacle.

**⚠ Caution: Physical and Secondary Damage**

- If using the equipment as a power source for medical equipment, you must check with the medical equipment manufacturer, doctor and hospital before using the equipment.

- 1) Turn off the switches of devices being used.
- 2) Turn all breakers (Main, 1-P 120/240V and 1-P 120V) to "OFF".
- 3) Start the engine. (Refer to section "8-1. Starting the Engine".)
- 4) Connect the power plug(s) of device(s) being used to the AC output receptacle(s).
- 5) Turn all breakers (Main, 1-P 120/240V and 1-P 120V) to "ON". (Check that the ELCB lever is set to "ON".)

**<Note>**

- During operation, the three phase 240V output voltage of the AC power source is constantly displayed regardless of whether the breaker is set to "ON" or "OFF".

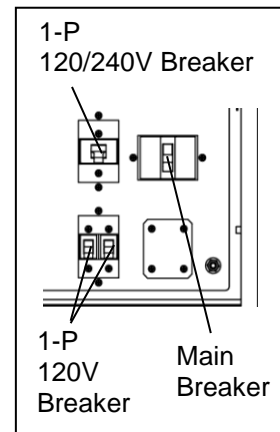

■ Recovery from Overcurrent Breaker Operation

**⚠ Caution: Injury**

- Always be sure to turn off the power switches of all devices using the equipment when turning on the equipment breakers. Leaving on the power switch of a device using the equipment when the equipment breakers are turned on could result in the sudden operation of the corresponding device.

Breakers operate when there is excessive current to isolate the corresponding circuit. Inspect the breakers if a device being used stops during equipment operation.

Follow the following procedures to recover operation when breakers operate due to overcurrent.

- 1) Turn off all switches of devices using the equipment as an AC power source.
- 2) Push the breaker lever that has operated to the "ON" position.

**<Note>**

- Refer to section "10-2. Usable Device Capacities" and be careful of overloading.

**11. Simultaneously Welding and Using as AC Power Source**

Due to the fact that breakers only function for AC power output, the engine can become overloaded if simultaneously welding and using the equipment as an AC power source. Refer to the table below and limit the use of AC power accordingly.

Overview of Capacities Usable Simultaneously (50/60Hz)

Weld Output		AC Power Output			
Amount of Personnel	Current	3-phase Output (Power factor: 0.8)		1-phase Output (Power factor: 1.0)	
Used by 1 Person [SINGLE] or [DUAL]	50A	PLUS	OR	10.0 / 12.0 kVA	8.0 / 10.0 kW
	100A			8.5 / 10.5 kVA	6.5 / 8.5 kW
	150A			6.5 / 9.0 kVA	5.0 / 7.0 kW
	200A			4.5 / 7.0 kVA	3.5 / 5.5 kW
	250A			2.0 / 4.5 kVA	1.5 / 3.5 kW
	300A			0 / 2.0 kVA	0 / 1.5 kW
	350A			0 / 0 kVA	0 / 0 kW
	400A			0 / 0 kVA	0 / 0 kW
Used by 2 Persons [DUAL]	50A x2			9.0 / 11.0 kVA	7.0 / 8.5 kW
	100A x2			6.0 / 7.5 kVA	4.5 / 6.0 kW
	150A x2			2.0 / 4.0 kVA	1.5 / 3.0 kW
	200A x2			0 / 0 kVA	0 / 0 kW

\*1-phase output is the total output of three receptacles.

**<Note>**

- Do not use as an AC power source simultaneously with welding if it is necessary to perform high-quality welding.

## 12. Inspection/Maintenance

### California Proposition 65

#### **WARNING**

Batteries, battery posts, terminals and related accessories contain lead and lead compounds, and other chemicals known to the State of California to cause cancer and birth defects or other reproductive harm. WASH HANDS AFTER HANDLING.

#### **Warning: Electric Shock/Injury**

- Always be sure to stop the engine before performing any equipment check or maintenance.
- Do not operate the equipment with any doors or covers open. There is a danger of hair, body parts and other items being caught up in moving parts such as cooling fans and belts.
- Do not modify the equipment and do not operate with parts removed.

#### **Warning: Fire**

- Always be sure to stop the engine when inspecting fuel or refueling, and absolutely never perform such tasks near fire or other open flame. Wait until the engine has completely cooled before inspecting fuel or refueling.
- Always be sure to wipe up any spilled fuel or oil.
- Spilled fuel and oil accumulates in the spill containment. Do not operate the equipment with liquid accumulated in the spill containment.
- Absolutely never use the equipment if there is a fuel, oil or cooling water leak, and be sure to always repair the leak before using.
- Absolutely never inspect or perform maintenance to the equipment near fire or other open flame.

#### **Warning: Injury to Eyes and Skin**

- Use protective gear, such as rubber gloves, when inspecting or replacing the battery due to the dilute sulfuric acid in the battery fluid. Be sure that fluid does not get into eyes, or on skin or clothing.
- If battery fluid gets into the eyes, or on the skin or clothing, immediately wash with a large amount of water, and always be especially sure to seek medical attention if it gets into the eyes.

#### **Warning: Explosion**

- Do not operate the equipment or recharge the battery when the battery fluid level is below the lower level.
- Do not generate any sparks near the battery and do not allow any fire or other open flame near the equipment because the battery generates ignitable gas.

#### **Caution: Burn**

- The engine, muffler and similar parts are extremely hot during operation and immediately after stopping the equipment. Never touch hot parts.
- Never open the radiator cap during operation or immediately after stopping the equipment. Hot cooling water and steam will spurt out.
- Always be sure to stop the engine and allow it to cool before inspecting or changing the engine oil. Opening the oil gauge or oil plug during operation will result in hot oil spurting out.

**<Note>**

- Procedures except for pre-operation inspection must be performed by specialized technicians.
- Items indicated by ●: Contact the retail outlet where the equipment was purchased.
- Always be sure to use genuine parts when replacing parts.
- When removing waste liquid from the equipment, place some container to collect the liquid and prevent it from spilling on the ground. Dispose of such oil, fuel, cooling water (LLC), filters, batteries and other harmful substances as industrial waste in accordance with applicable laws and regulations. Consult with the retail outlet where the equipment was purchased if you have any inquiries regarding proper disposal.
- When performing maintenance with doors or covers open, be sure that no other persons can accidentally come close to the equipment. Close all doors and covers if momentarily leaving the equipment unattended.

Perform periodic inspection and maintenance as indicated by the table below in order to ensure that this equipment can be operated in optimal condition.  
Use the hour meter as a general indicator for the operating time.

Inspection Item		Pre-Operation Inspection	Inspection Period					Every 2,000 hours
			50th hour	Every 100 hours	Every 200 hours	Every 400 hours	Every 1,000 hours	
1	Inspect/Add Fuel	○						
2	Inspect/Add Engine Oil	○						
3	Change Engine Oil		1st time ○	2nd time and after ○				
4	Change Oil Filter		1st time ○		2nd time and after ○			
5	Inspect/Add Cooling Water	○						
6	Change Cooling Water							○ or 1 year
7	Clean Fuel Strainer		1st time ○	2nd time and after ○				
8	Replace Fuel Element					○		
9	Drain Water from/Clean Fuel Tank				○			
10	Inspect for Fuel/Oil/Cooling Water Leakage	○						
11	Inspect/Add Battery Fluid	○						
12	Clean Air Element		1st time ○	2nd time and after ○				
13	Replace Air Element					○		
14	Drain Liquid from Spill Containment	○						
15	Adjust V-belt Tension		1st time ●	2nd time and after ●				
16	Replace V-belt					● or 2 years		

Inspection Item	Pre-Operation Inspection	Inspection Period					
		50th hour	Every 100 hours	Every 200 hours	Every 400 hours	Every 1,000 hours	Every 2,000 hours
17 Clean Radiator Fin (External)					●		
18 Clean Radiator (Internal)					●		
19 Inspect/Replace Fuel/Cooling Water/Oil Hoses, Anti-Vibration Rubber and Packing in Top and Bottom of Fuel Tank					○ or 1 years (Inspect)		● or 2 years
20 Adjust/Lap Clearance of Air Intake/Release Valves						● Adjust- ment	● Lapping
21 Inspect/Adjust Clearance of Fuel Injection Valves					●		
22 Inspect/Adjust Fuel Injection Pump							●
23 Clean/Inspect Spill Containment					● or 1 year		

### (1) Changing the Engine Oil

1st time	50th hour
2nd time and after	Every 100 hours

- 1) Remove the oil plug.
- 2) Remove the oil drain plug and drain the engine oil.
- 3) Tighten the oil drain plug.
- 4) Add oil through the oil inlet, while checking the oil level using the oil gauge, until it reaches the maximum level. (Fill with approx. 3.6 L)
- 5) Tighten the oil plug.

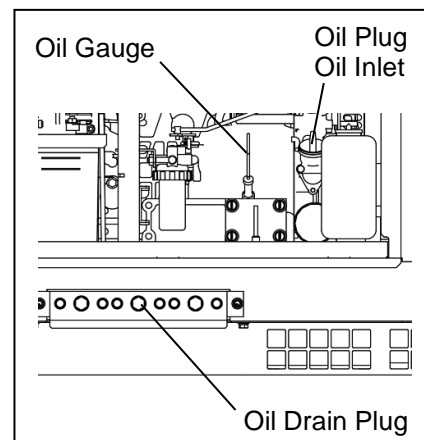

#### <Note>

- Refer to section "7-1. Engine Oil Inspection" for the types of engine oil.
- Replace the packing of the oil drain plug with a new part each time the oil is changed.
- Packing part no. : 6C090-58961 (Kubota part no.)
- After tightening the oil drain plug, operate the engine for a short period and check that there is no oil leakage. Stop the engine when completed.

### (2) Changing the Oil Filter

1st time	50th hour
2nd time and after	Every 200 hours

- 1) Drain the engine oil according to the procedures of "(1) Changing the Engine Oil".
- 2) Remove the oil filter using a filter wrench.
- 3) Apply a thin layer of oil to the gasket of a new oil filter.
- 4) Screw in the oil filter by hand and securely tighten by hand (do not use a filter wrench) after the gasket contacts the seal surface.
- 5) Add engine oil.

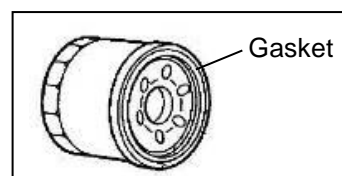
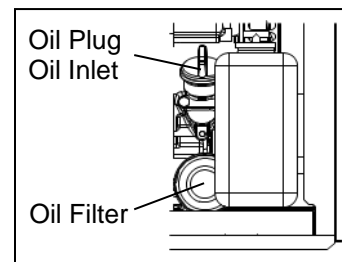

**<Note>**

- Contact the retail outlet where the equipment was purchased if you do not have a filter wrench.
- Oil filter part no. : 1J090-32430 (Kubota part no.)
- After adding engine oil, operate the engine for a short period and check that there is no oil leakage. Stop the engine when completed.

**(3) Cleaning/Replacing the Air Element**

Cleaning	1st time: 50th hour / 2nd time and after: Every 100 hours
Replacement	Every 400 hours

- 1) Release the air cleaner clips and remove the cleaner cap.
- 2) Clean or replace the air element.  
 <If dry dust is adhering>  
 Spray compressed air from within the element.  
 <If carbon or oily substance is adhering>  
 Replace with a new part.
- 3) Install in the reverse order of removal.

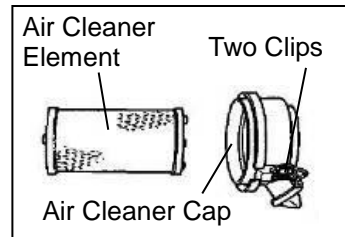
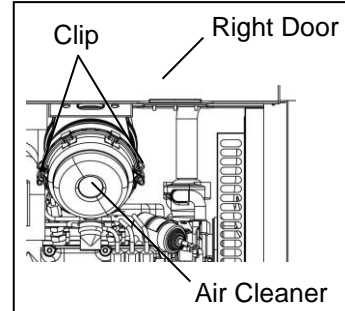

**<Note>**

- Clean sooner than scheduled if using the equipment in a dusty location.
- Element part no. : 1G319-11211 (Kubota part no.)

**(4) Cleaning/Replacing the Fuel Strainer**

Cleaning	1st time: 50th hour / 2nd time and after: Every 100 hours
Replacement	Every 400 hours

- 1) Turn the fuel lever to "CLOSE".
- 2) Turn the retainer ring to the left and remove the cup and element.
- 3) Remove any water or foreign material from the cup and clean the element using compressed air. (Or replace the element.)
- 4) Install in the reverse order of removal.

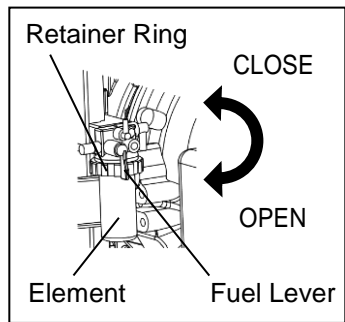
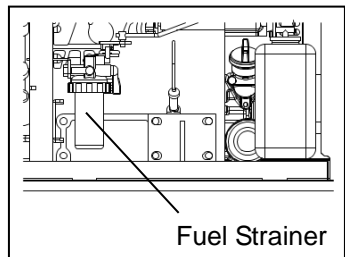

**<Note>**

- Check that no foreign material is adhering to the packing then install the cup.
- After installation, turn the fuel lever to "OPEN" and check that there is no fuel leakage. After checking, turn the fuel lever to "CLOSE".
- Element part no. : 16271-43561 (Kubota part no.)

**(5) Draining Water from the Fuel Tank**

Draining Water	Every 200 hours
----------------	-----------------

- 1) Remove the fuel drain plug.
- 2) Drain the water and tighten the fuel drain plug.

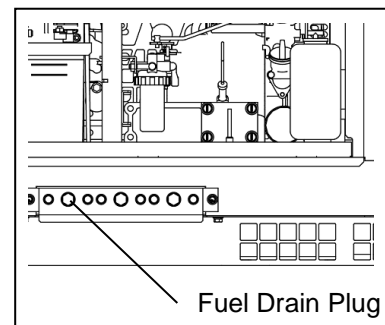

**<Note>**

- Replace the packing with a new part each time you drain the water.
- Packing part no. : 6C090-58961 (Kubota part no.)
- Always be sure to check that there is no fuel leakage after tightening the fuel drain plug.

**(6) Changing the Cooling Water**

Change	Every 2,000 hours or 1 year
--------	-----------------------------

Cooling Water Total Capacity: Approximately 4 L  
(Including the sub tank capacity of approx. 0.6 L)

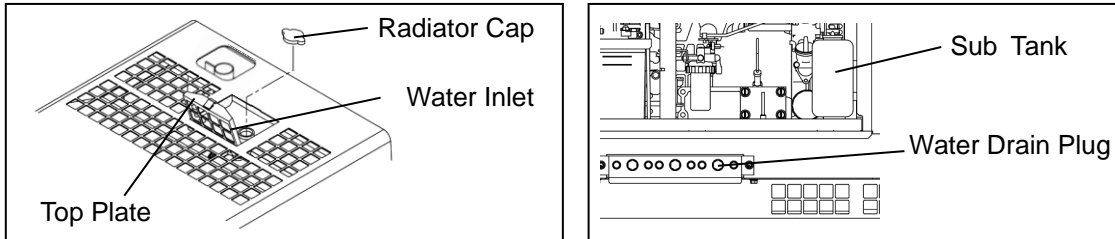

- 1) Open the top plate.
- 2) Remove the radiator cap.
- 3) Remove the water drain plug.
- 4) Drain the cooling water and tighten the water drain plug.
- 5) Change the cooling water in the sub tank.
- 6) Pour cooling water into the water inlet until it reaches the mouth of the port.
- 7) Tighten the radiator cap.
- 8) Close the top plate.

**<Note>**

- Replace the packing with a new part each time you change the cooling water.
- Packing part no. : 6C090-58961 (Kubota part no.)
- Operate the engine for a short period and check that there is no cooling water leakage. Stop the engine when completed.

**(7) Draining Liquid from the Spill Containment**

Drain	Pre-operation
-------	---------------

- 1) Set a receptacle under the drain port of the spill containment to catch the liquid.
- 2) Remove the plug (R 1/2") of the spill containment drain valve and turn the lever to "OPEN".
- 3) After draining the liquid, turn the lever to "CLOSE", and apply sealing agent to the plug (R 1/2") or wrap it with sealing tape before tightening the plug.

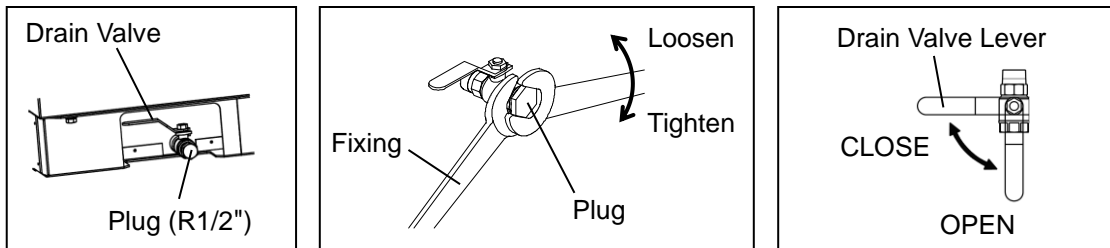

**<Note>**

- Secure the drain valve body using a spanner or similar tool so that it does not loosen when removing/installing the plug by turning it.
- It is possible that there is a fuel or oil leak if the drained fluid contains oily components. If this occurs, check for leakage locations.
- Although the fluids that can leak internally consist of oil, fuel, cooling water and battery fluid, the spill containment does not have a function that can separate rainwater that has leaked into the equipment from these internally leaked fluids. Properly dispose of liquid drained from the spill containment in a manner according to the applicable laws and regulations.

**(8) Cleaning/Inspecting the Spill Containment**

Cleaning	Every 400 hours or 1 year
----------	---------------------------

**⚠ Caution: Injury**

- Always be sure to use the lifting lug when lifting the equipment, and lift slowly and directly straight above.
- Wear a helmet, safety shoes, gloves and similar protective gear when performing lifting work. Do not stand or get under the equipment while it is suspended.
- For cleaning/inspecting the spill containment, set this equipment with it situated on a stable level surface so that it is prevented from moving.

- 1) Drain the liquid from the spill containment.
- 2) Remove the seven installation bolts (M8) of the spill containment.
- 3) Lift up the equipment body to separate the spill containment and set the equipment on a level surface.
- 4) Clean the inside of the spill containment using a high-pressure washer or similar equipment.
- 5) Drain the cleaning liquid from the spill containment.
- 6) Remove any rust that has formed in the spill containment and paint it again.
- 7) Pour water into the spill containment and check that there is no leakage. (After checking, drain the water you have used.)
- 8) Install the spill containment to the equipment in the reverse order of removal.

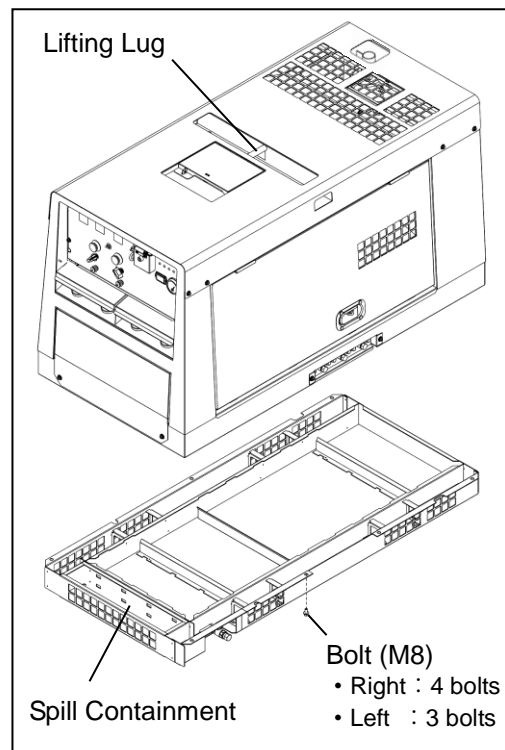

**<Note>**

- Do not operate the equipment with the spill containment separated.
- If liquid drained from the spill containment during cleaning contains oily components, dispose of it in a manner according to the applicable laws and regulations.
- If the spill containment has a leak, request repair at the retail outlet where the equipment was purchased.

**(9) Inspecting/Replacing the Fuel/Cooling Water/Oil Hoses, Anti-Vibration Rubber and Packing in Top and Bottom of Fuel Tank.**

Inspect	Every 400 hours or 1 year
Replacement	Every 2,000 hours or 2 year

If rubber hoses (fuel, cooling water, oil, air, drain, etc.) are hardened or deteriorated, please replace with a new rubber hose.

For rubber hose replacement, please contact the retail outlet where the equipment was purchased.

## 13. Long-Term Storage

**⚠ Warning: Electric Shock/Injury**

- Always be sure to stop the engine before performing any equipment check or maintenance.
- Do not operate the equipment with any doors or covers open. There is a danger of hair, body parts and other items being caught up in moving parts such as cooling fans and belts.

**⚠ Warning: Fire**

- Always be sure to stop the engine when inspecting fuel or refueling, and absolutely never perform such tasks near fire or other open flame. Wait until the engine has completely cooled before inspecting fuel or refueling.
- Always be sure to wipe up any spilled fuel or oil.
- Spilled fuel and oil accumulates in the spill containment. Do not leave the equipment with liquid accumulated in the spill containment.

**⚠ Caution: Burn**

- The engine, muffler and similar parts are extremely hot during operation and immediately after stopping the equipment. Never touch hot parts.
- Always be sure to stop the engine and allow it to cool before inspecting or changing the engine oil. Opening the oil gauge or oil plug during operation will result in hot oil spurting out.

Perform the following maintenance procedures if not using the equipment for two months or more.

- 1) Remove the battery. (Refer to section "7-6. Battery Inspection".)
- 2) Change the engine oil. (Refer to section "12.(1) Changing the Engine Oil".)
- 3) Drain the fuel from the fuel tank and strainer.  
(Refer to section "12.(4) Cleaning/Replacing the Fuel Strainer".)
- 4) Clean and inspect the spill containment.  
(Refer to section "12.(8) Cleaning/Inspecting the Spill Containment".)
- 5) Clean all parts and store the equipment in an area with low humidity and little dust with a cover or similar protection covering it.

**<Note>**

- Recharge a removed battery approximately once every month.

## 14. Troubleshooting

### **⚠ Warning: Electric Shock/Injury**

- Always be sure to stop the engine before performing any equipment check or maintenance.
- Do not touch the equipment during operation if the equipment or your body is wet.
- Do not operate the equipment with any doors or covers open. There is a danger of hair, body parts and other items being caught up in moving parts such as cooling fans and belts.

### **⚠ Warning: Fire**

- This equipment uses diesel fuel. Always be sure to stop the engine when inspecting fuel or refueling, and absolutely never perform such tasks near fire or other open flame. Wait until the engine has completely cooled before inspecting fuel or refueling.
- Always be sure to wipe up any spilled fuel or oil.
- Spilled fuel and oil accumulates in the spill containment. Do not operate the equipment with liquid accumulated in the spill containment.
- Absolutely never use the equipment if there is a fuel, oil or cooling water leak, and be sure to always repair the leak before using.
- Absolutely never inspect or perform maintenance to the equipment near fire or other open flame.

### **⚠ Warning: Injury to Eyes and Skin**

- Use protective gear, such as rubber gloves, when inspecting or replacing the battery due to the dilute sulfuric acid in the battery fluid. Be sure that fluid does not get into eyes, or on skin or clothing.
- If battery fluid gets into the eyes, or on the skin or clothing, immediately wash with a large amount of water, and always be especially sure to seek medical attention if it gets into the eyes.

### **⚠ Warning: Explosion**

- Do not operate the equipment or recharge the battery when the battery fluid level is below the lower level.
- Do not generate any sparks near the battery and do not allow any fire or other open flame near the equipment because the battery generates ignitable gas.

### **⚠ Caution: Burn**

- The engine, muffler and similar parts are extremely hot during operation and immediately after stopping the equipment. Never touch hot parts.
- Never open the radiator cap during operation or immediately after stopping the equipment. Hot cooling water and steam will spurt out. Always be sure to stop the engine before performing any equipment check or maintenance.
- Always be sure to stop the engine and allow it to cool before inspecting or changing the engine oil. Opening the oil gauge or oil plug during operation will result in hot oil spurting out.

Refer to the table on the next page to perform inspection when the equipment is operating poorly.

If you cannot resolve a problem after inspecting the equipment, request repair at the retail outlet where the equipment was purchased.

Symptom	Possible Causes	Remedy
Starter motor does not start.	<ol style="list-style-type: none"> <li>1. Battery has a low charge.</li> <li>2. Battery is deteriorated.</li> </ol>	<ol style="list-style-type: none"> <li>1. Recharge the battery.</li> <li>2. Replace the battery.</li> </ol>
Engine does not start.	<ol style="list-style-type: none"> <li>1. Fuel lever is "CLOSE".</li> <li>2. Emergency stop switch is "ON".</li> <li>3. No fuel.</li> <li>4. Water or foreign material is mixed in with the fuel.</li> <li>5. Blown fuse.</li> </ol>	<ol style="list-style-type: none"> <li>1. Turn the fuel lever to "OPEN".</li> <li>2. Release the emergency stop switch.</li> <li>3. Add fuel.</li> <li>4. Drain water from and clean the fuel tank and fuel strainer.</li> <li>5. Replace the fuse.</li> </ol>
No weld output.	<ol style="list-style-type: none"> <li>1. Weld terminal switch is set to "REMOTE CONTROL".</li> </ol>	<ol style="list-style-type: none"> <li>1. Set to "WELD TERMINALS ON".</li> </ol>
Engine starts but quickly stops.	<ol style="list-style-type: none"> <li>1. Insufficient oil.</li> <li>2. Overheating of water temperature.</li> <li>3. Battery recharging fault.</li> </ol>	<ol style="list-style-type: none"> <li>1. Add oil.</li> <li>2. Comply with rated outputs/Add cooling water.</li> <li>3. Repair.</li> </ol>
Black or white smoke is continuously exhausted from the muffler.	<ol style="list-style-type: none"> <li>1. Overloaded.</li> </ol>	<ol style="list-style-type: none"> <li>1. Comply with the rated outputs.</li> </ol>
Engine does not stop.	<ol style="list-style-type: none"> <li>1. Stop solenoid fault.</li> </ol>	<ol style="list-style-type: none"> <li>1. Turn the fuel lever to "CLOSE" to stop the engine.</li> </ol>
Weak welding arc	<ol style="list-style-type: none"> <li>1. Single/Dual selector is set to "DUAL".</li> <li>2. Faulty cable connection.</li> <li>3. Improper cable. (excessively thin)</li> <li>4. Faulty connection with base material.</li> <li>5. Using simultaneously as AC power source.</li> <li>6. Welding cable short circuit.</li> </ol>	<ol style="list-style-type: none"> <li>1. Set to "SINGLE".</li> <li>2. Connect securely.</li> <li>3. Replace with cable according to "Welding Cable Selection".</li> <li>4. Connect securely.</li> <li>5. Do not use as AC power source.</li> <li>6. Remove the cause of the short circuit.</li> </ol>
Strong welding arc	<ol style="list-style-type: none"> <li>1. Single/Dual selector is set to "SINGLE".</li> <li>2. Arc control setting is excessively strong.</li> </ol>	<ol style="list-style-type: none"> <li>1. Set to "DUAL".</li> <li>2. Turn the arc control dial to the left.</li> </ol>
Wire feeder cannot be used.	<ol style="list-style-type: none"> <li>1. "DROOP-STICK", "GOUGING", "LIFT START TIG" or "CC-STICK" weld mode has been selected.</li> <li>2. Poor connection of the wire feeder connector.</li> <li>3. Circuit protector for the wire feeder has operated.</li> </ol>	<ol style="list-style-type: none"> <li>1. Set to "CV-WIRE".</li> <li>2. Securely connect the wire feeder connector.</li> <li>3. Reset the circuit protector for the wire feeder.</li> </ol>
Weld output cannot be adjusted.	<ol style="list-style-type: none"> <li>1. Remote controller is connected.</li> </ol>	<ol style="list-style-type: none"> <li>1. Disconnect the remote controller. Or, adjust using the remote controller.</li> </ol>
No AC power output	<ol style="list-style-type: none"> <li>1. Breaker is "OFF".</li> </ol>	<ol style="list-style-type: none"> <li>1. Turn the breaker to "ON".</li> </ol>
AC power output is weak.	<ol style="list-style-type: none"> <li>1. The current of devices using the equipment exceed the rated current.</li> <li>2. Using simultaneously for welding.</li> </ol>	<ol style="list-style-type: none"> <li>1. Refer to "Usable Device Capacities".</li> <li>2. Stop welding.</li> </ol>
Engine cannot obtain high speed.	<ol style="list-style-type: none"> <li>1. Idle control switch is set to "ECO".</li> <li>2. Current of device using the equipment as AC power source is 0.5A or less.</li> </ol>	<ol style="list-style-type: none"> <li>1. Set to "HIGH" or "AUTO".</li> <li>2. Set the idle control switch to "HIGH".</li> </ol>
Engine cannot obtain low speed.	<ol style="list-style-type: none"> <li>1. Idle control switch is set to "HIGH".</li> <li>2. Welding cable short circuit.</li> </ol>	<ol style="list-style-type: none"> <li>1. Set to "ECO" or "AUTO".</li> <li>2. Remove the cause of the short circuit.</li> </ol>

Symptom	Possible Causes	Remedy
VRD does not work.	1. VRD switch is set to "OFF". 2. "CV-WIRE" weld mode has been selected.	1. Set to "ON". 2. Set to "DROOP-STICK", "GOUGING", LIFT START TIG" or "CC-STICK".

### ■ Error Code Display

Error codes are displayed on the DC and AC meters when the control board detects an error. If the error code is displayed, follow to the procedures in the "Remedy".

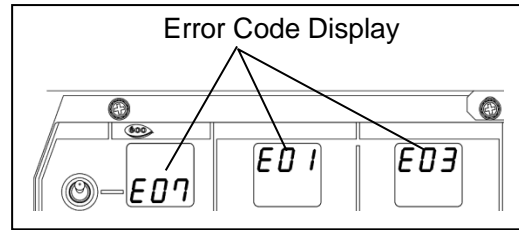

Error Code	Symptom	Remedy
E01	Overheating of control parts for welding	Set the idle control switch to "AUTO" or "ECO". Run the engine to cool it down at idle under no-load until the "E01" display disappears.  * This error is automatically resolved when temperature of the control parts lowered to normal.
E02	Fault/Malfunction of control parts for welding	Stop the engine and repair the location of the fault.  * DO NOT restart the engine unless the fault is repaired.
E03	Short circuit of the weld output	Stop the engine. Return the short circuit of the weld output and restart the engine.
E07	Overheating of alternator	As the engine continue to run even after "E07" is displayed, remain the engine run for approx. 10 minutes to cool the alternator down. Display will change "E07" to "..." after engine run for approx. 10 minutes. Then, stop and restart the engine.  * When the alternator will not cool down insufficiently, "E07" is displayed again and repeat the remedy. * Engine rpm remains the same when this failure happens although position of the idle control switch is changed. The rpm is unchanged after the sensor detects overheat until it is fixed.
...	RUN/STOP SWITCH is kept at "RUN".	Set the RUN/STOP switch to "STOP" position. Or restart the engine the starter switch is pushed.  * "..." is also displayed when "E07" is displayed and engine run for approx. 10 minutes.

### <Note>

- Maintenance of this equipment must be performed by specialized technicians.
- When performing maintenance with doors or covers open, be sure that no other persons can accidentally come close to the equipment. Close all doors and covers if momentarily leaving the equipment unattended.
- A simple inspection cannot always resolve some problems. If you cannot resolve a problem after inspecting the equipment, request repair at the retail outlet where the equipment was purchased.

# 15. Engine Wiring Diagram

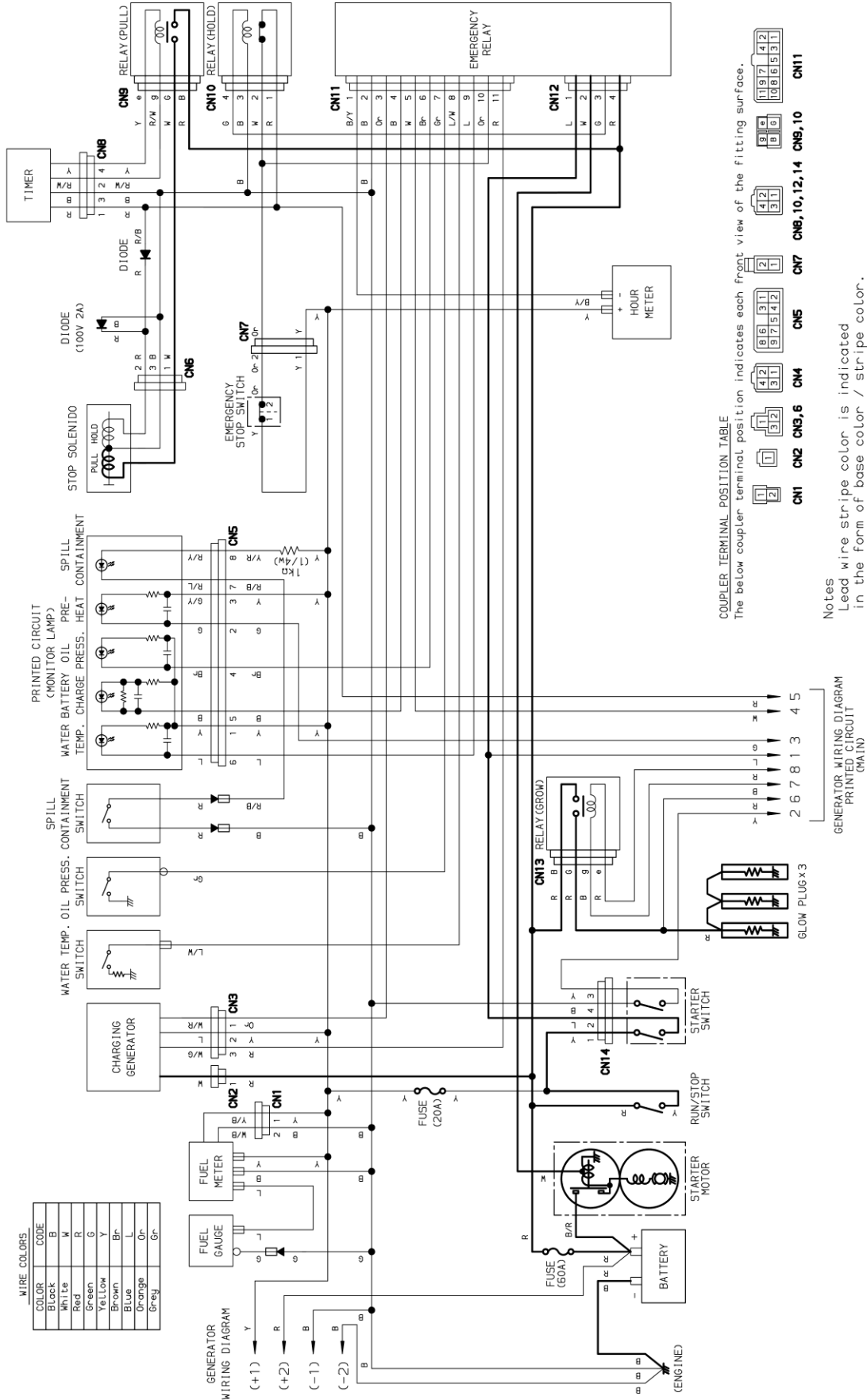

COUPLER TERMINAL POSITION TABLE  
 The below coupler terminal position indicates each front view of the fitting surface.



Notes  
 Lead wire stripe color is indicated  
 in the form of base color / stripe color.

# 16. Generator Wiring Diagram

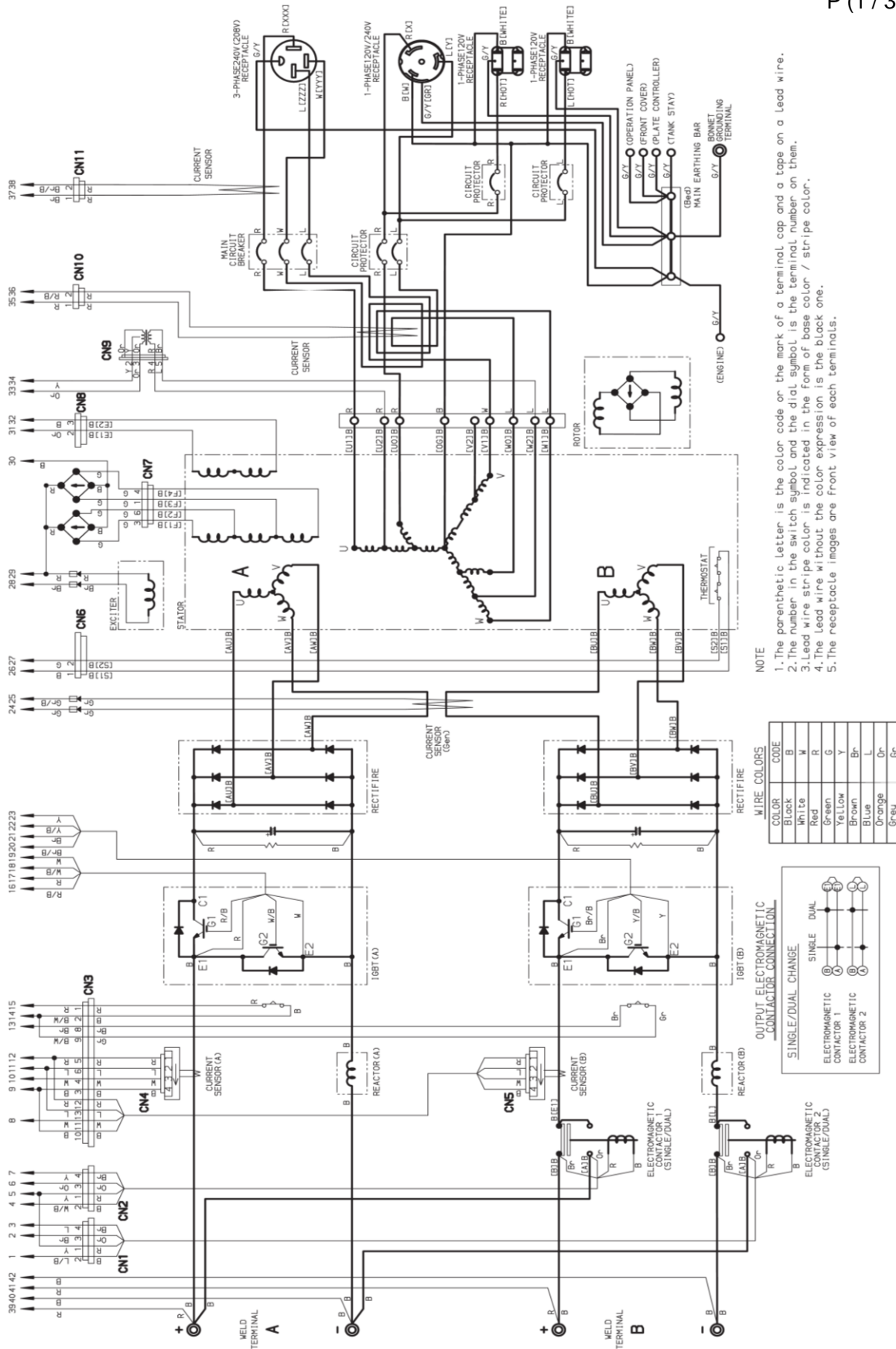

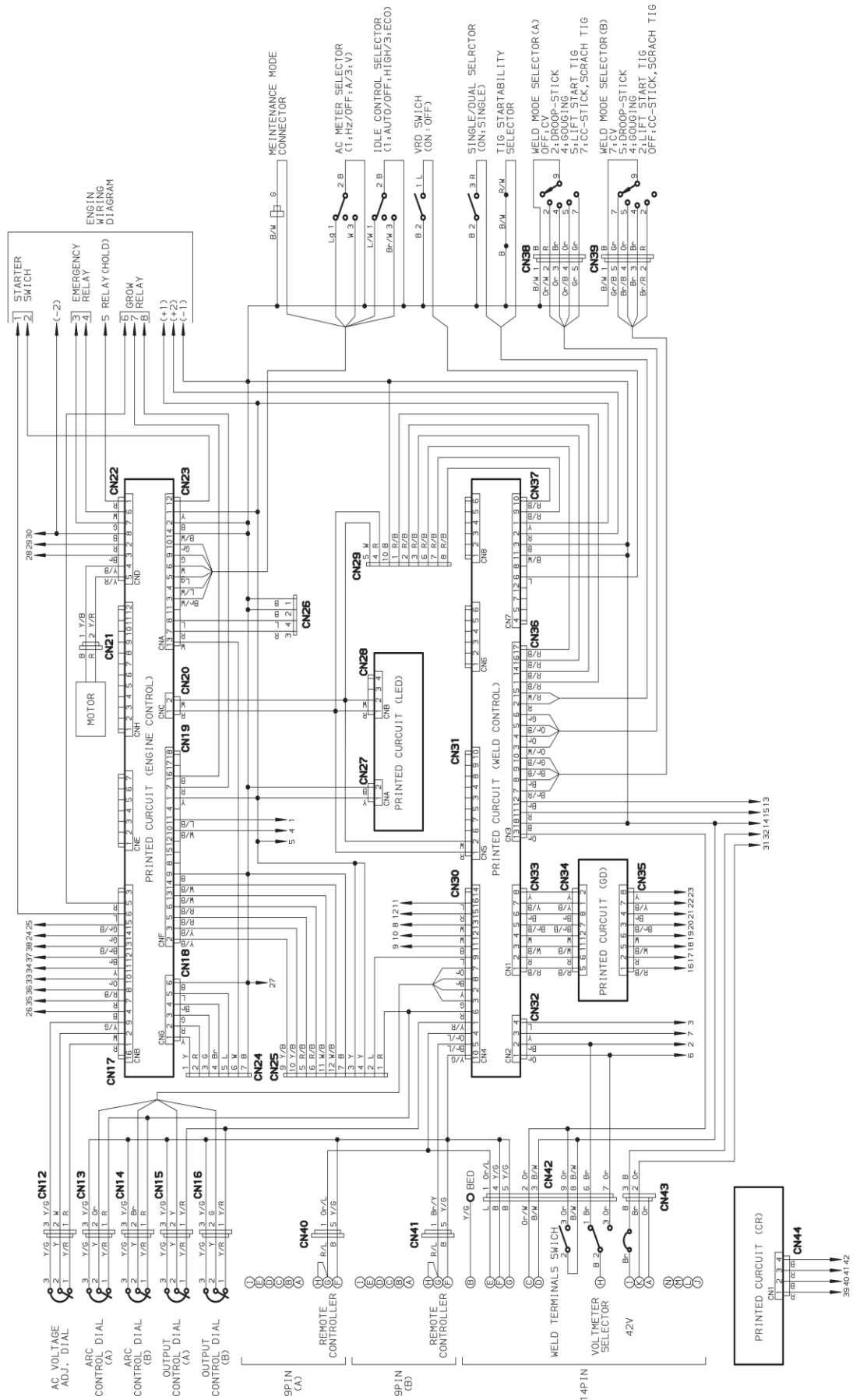



**CN1, 2, 26, 28, 32**

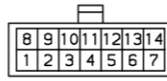

**CN3, 23**

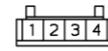

**CN4, 5**

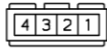

**CN6**

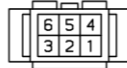

**CN7**



**CN8**



**CN9**



**CN10, 11**



**CN12, 13, 14, 15, 16**

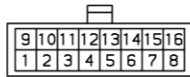

**CN17, 30**



**CN18, 38, 39, 40, 41**

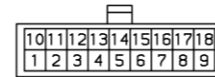

**CN19, 36**



**CN20, 21, 27**

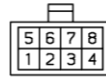

**CN22, 33, 35**

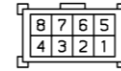

**CN24**

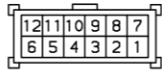

**CN25**

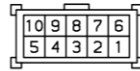

**CN29**

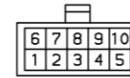

**CN31, 42**

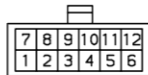

**CN34, 37**



**CN43**



**CN44**



**YAMABIKO CORPORATION**  
7-2 SUEHIROCHO 1-CHOME, OHME, TOKYO 198-8760, JAPAN  
PHONE: 81-428-32-6118. FAX: 81-428-32-6145.

**shindaiwa<sup>®</sup>**