

20" Power Dethatching Rake



WARNING

READ AND UNDERSTAND THIS OPERATOR'S MANUAL COMPLETELY BEFORE USING THIS ATTACHMENT. ASSEMBLE, TEST AND USE ONLY IN ACCORDANCE WITH THE OPERATOR'S MANUAL INSTRUCTIONS.

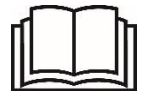



Table of Contents

- 1. Safety3
- 1.1 Safety Precautions 3
- 1.2 Operating Safety 3
- 1.3 Mechanical Hazards 4
- 1.4 Fire and Explosion Hazards 4
- 1.5 Chemical Hazards 4
- 1.6 Noise Hazards..... 5
- 1.7 Protective clothing 5
- 1.8 Operator Safety using Internal Combustion Engines..... 5
- 1.9 Un-Crating..... 6
- 1.10 Key Components 6
- 1.11 Label Locations..... 6
- 1.12 Safety and Operating Labels 7
- 1.12 Safety and Operating Labels 7
- 1.12 Safety and Operating Labels (cont.) 9
- 2. Technical Data..... 9
- 2.1 Specifications 9
- 2.2 Dimensions In..... 9
- 3. Operation10
- 3.1 Operating Principle10
- 3.2 Delivery Checks10
- 3.3 Before Starting10
- 3.4 Starting Gasoline Engine10
- 3.5 To Stop11
- 4. Operation11
- 5. Parts12
- 6. Maintenance.....14
- 6.1 Periodic Maintenance Schedule.....14
- 6.2 V-Belt.....14
- 6.3 Replacing the V-Belt14
- 6.4 Air Cleaner15
- 6.5 Spark Plug.....15
- 6.6 Transporting15

1. Safety

1.1 Safety Precautions



Before using this equipment, study the operator's manual to become familiar with its operation. Do NOT allow un-trained or unauthorized persons, especially children, to operate this equipment. Use only factory authorized parts for service.

	<p>This is the safety alert symbol. It is used to alert you to potential personal injury hazards. Obey all safety messages that follow this symbol to avoid possible injury or death.</p>
	<p>DANGER (red) indicates an imminently hazardous situation which, if not avoided, will result in death or serious injury.</p>
	<p>WARNING (orange) indicates a potentially hazardous situation which, if not avoided, could result in death or serious injury.</p>
	<p>CAUTION (yellow) indicates a potentially hazardous situation which, if not avoided, may result in minor or moderate injury.</p>
	<p>CAUTION (yellow) used without the safety alert symbol indicates a potentially hazardous situation which, if not avoided, may result in property damage.</p>

fig01453

1.2 Operating Safety



- Slip/Trip/Fall is a major cause of serious injury or death. Beware of uneven or slippery work surfaces.
- Exercise care when working in the vicinity of unprotected holes or excavations.
- NEVER allow any person to operate this equipment without adequate instruction.
- Ensure all operators read, understand, and follow the operating instructions.
- Serious injury could result from improper or careless use of this machine.
- Power Dethatchers are heavy units and should be positioned by two people of appropriate strength. Use correct lifting techniques.

1.3**Mechanical Hazards**

- DO NOT operate the machine unless all protective guards are in place.
- Keep hands and feet clear of rotating and moving parts as they will cause injury if contacted.
- Ensure that the engine operation switch is in the OFF position and the spark plug ignition lead is disconnected, and the engine id cool before removing guards or making adjustments.
- Ensure both the machine and the operator are stable by setting up on level terrain so the machine will not tip over, slide, or fall while in operation or unattended.
- Do not leave the machine running while unattended.
- Never clamp, tie, or tape the bail to the handlebar. Do not defeat any safety features.
- Ensure that the area to be raked does not contain any live electrical cables, gas, water, sprinkler, communication cables or any other utilities.
- Exercise care when operating unit. Exposure to vibration or repetitive work actions may be harmful to hands and arms.
- NEVER stand on the unit while it is operating. NEVER allow others to stand on the unit.
- Be careful not to come in contact with the muffler when the engine is hot. This will cause burns.
- Ensure that the repairs to the motor and machine are carried out by qualified personnel.



**Know what's below.
Call before you dig.**

**1.4 Fire and Explosion Hazards**

- Gasoline is extremely flammable and explosive under certain conditions.
- Ensure that gasoline is only stored in approved storage containers.
- DO NOT refuel the motor while it is running. Allow the motor to totally cool before refueling.
- DO NOT refuel the motor in the vicinity of sparks, flame, or anyone smoking.
- DO NOT overfill the fuel tank and avoid spilling gasoline when refueling. Spilled gasoline or gasoline vapor may ignite. If spillage occurs, ensure that the area is cleaned and dry before starting the motor.
- Ensure that the fuel cap is securely fitted after refueling.
- Do not refuel in an enclosed space, such as a covered trailer.

**1.5 Chemical Hazards**

- DO NOT operate or refuel a gasoline engine in a confined space or any area without adequate ventilation.
- Carbon monoxide and other components of exhaust gases from internal combustion engines can cause death in confined spaces.

**1.6 Noise Hazards**

- Excessive noise can lead to temporary or permanent loss of hearing.
- Wear an approved hearing protection device to limit noise exposure.

**1.7 Protective clothing**

- Always wear approved hearing and eye protection when working with the machine.
- A dust mask should be worn.
- Protective clothing and footwear are required.
- Do not wear any open-toed shoes or sandals.

**1.8 Operator Safety using Internal Combustion Engines**

- DO NOT smoke when refueling the engine or during any other fuel handling operation.
- DO NOT refuel a hot or running engine.
- DO NOT refuel the engine near an open flame or sparks.
- DO NOT spill fuel when refueling the engine.
- If fuel is spilled during refueling, wipe it off from the engine immediately and discard the rag in a safe place.
- DO NOT operate the unit if fuel or oil leaks exist. Repair immediately.
- Never operate this equipment in an explosive atmosphere or anywhere combustible gases have accumulated.
- Never operate any gas-powered equipment in a poorly ventilated or enclosed area.
- Avoid prolonged breathing of exhaust gases.
- Avoid contact with hot exhaust systems and engine parts.
- Allow engine to cool before performing any repairs, adjustments, or service.
- Always transport and handle fuel only in approved safety containers.
- Always keep the area around the muffler free of debris such as leaves, grass, paper cartons or anything combustible. A hot muffler could ignite debris and start a fire.

1.9 Un-Crating

The Dethatcher comes completely assembled with the handle folded. Carefully remove the Dethatcher from the carton. Rotate the handle up into position, ensuring that the handle lock rings slide down over the lock ramps on the handle brackets.

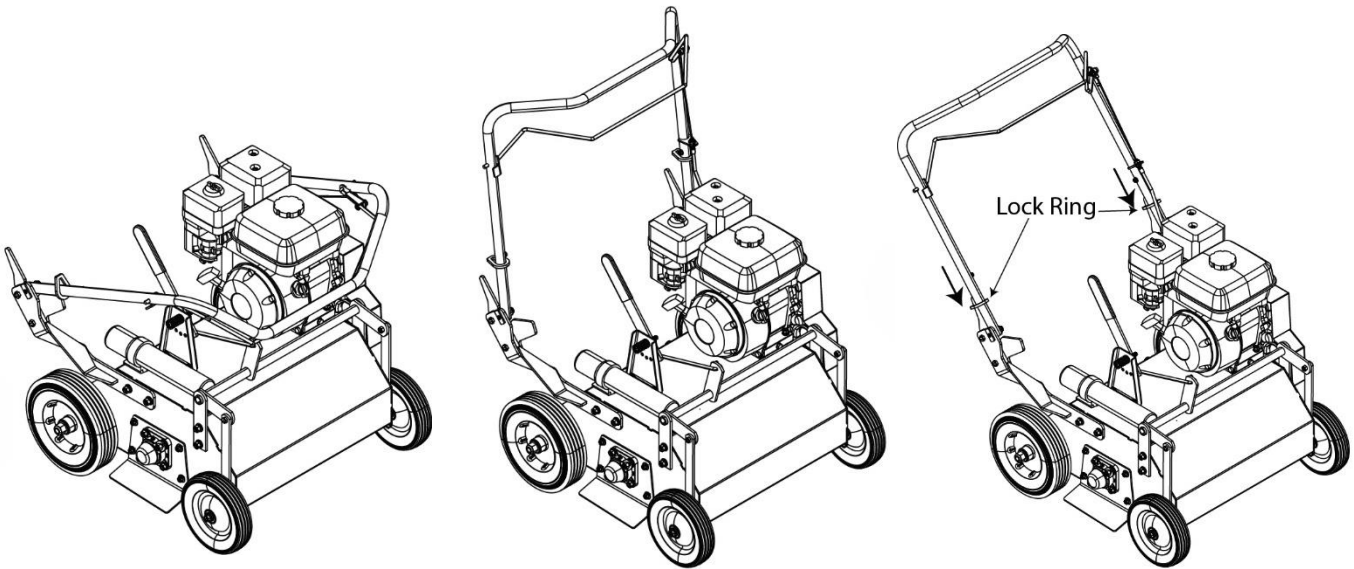

1.10 Key Components

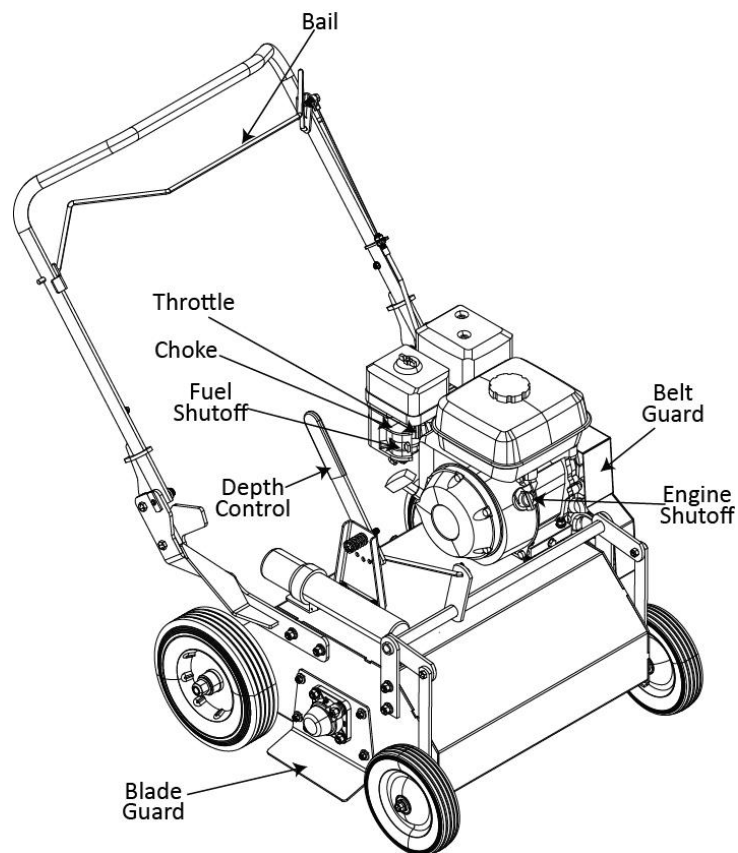



1.11 Label Locations











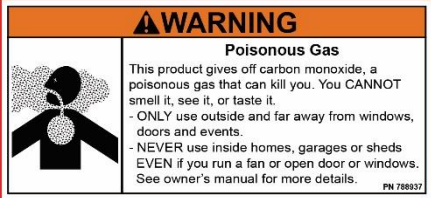

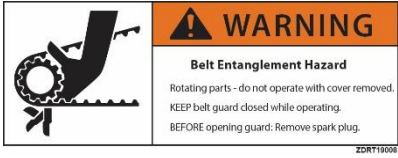

1.12 Safety and Operating Labels





Brave Pro Machines use international pictorial labels where needed. These labels are described below:

Label	Meaning
	<p>DANGER </p> <p>Never operate the Dethatcher without the guard in place.</p>

1.12 Safety and Operating Labels

Label	Meaning
 <p>WARNING Poisonous Gas This product gives off carbon monoxide, a poisonous gas that can kill you. You CANNOT smell it, see it, or taste it. - ONLY use outside and far away from windows, doors and events. - NEVER use inside homes, garages or sheds EVEN if you run a fan or open door or windows. See owner's manual for more details. PN 788937</p>	<p>DANGER </p> <p>Engines emit carbon monoxide; operate only in well-ventilated areas. Read the Operation Manual for machine information. No sparks, flames, or burning objects near the machine. Shut off the engine before refueling. Use only clean, filtered unleaded gasoline.</p>
 <p>WARNING Flying Debris Hazard • Touching them can cause eye injury and blindness. • Flying debris can be a hazard to operator or bystanders. • NEVER allow anyone to HANDLE ENGINE while operating. • ALWAYS position machine to protect properly from flying debris. • Wear long pants and closed shoes. • Wear eye, ear, and face protection.</p>	<p>WARNING </p> <p>Flying Debris Always wear hearing and eye protection when operating this machine.</p>
 <p>WARNING Belt Entanglement Hazard Rotating parts - do not operate with cover removed. KEEP belt guard closed while operating. BEFORE opening guard: Remove spark plug. ZDR119008</p>	<p>DANGER </p> <p>Keep hands, Feet and clothing clear of rotating belts and parts.</p>
 <p>WARNING FIRE HAZARD • Sparks can occur if blower motor strikes rocks, metal or other hard objects. • Do NOT use in high/very high fire hazard severity zones. • Operation of this equipment may create sparks that can start fires around dry vegetation. A spark arrester may be required. The operator should contact local fire agencies for laws and regulations relating to fire prevention requirements. PN 2021</p>	<p>CAUTION </p> <p>Fire Hazard. Do not use in high fire danger or dry conditions.</p>
 <p>WARNING BURN HAZARD Do not touch hot muffler. PN 786635</p>	<p>WARNING </p> <p>Hot mufflers and engines can cause burns.</p>
 <p>WARNING FIRE HAZARD • Sparks can occur if blower motor strikes rocks, metal or other hard objects. • Do NOT use in high/very high fire hazard severity zones. • Operation of this equipment may create sparks that can start fires around dry vegetation. A spark arrester may be required. The operator should contact local fire agencies for laws and regulations relating to fire prevention requirements. PN 2021</p>	<p>WARNING </p> <p>Fire hazard.</p>
 <p>LOWER TINES ↑ RAISE TINES ↓</p>	<p>Deck operation direction</p>

1.12 Safety and Operating Labels (cont.)

Label	Meaning
	<p>DANGER </p> <p>Keep hands, Feet and clothing clear of Blades.</p>
	<p>A nameplate listing the model number and serial number is attached to each unit. Please record the information found on this plate so it will be available if it is damaged. When requesting service information, the serial number should be specified of the unit.</p>
	<p>WARNING </p> <p>Exposure hazard.</p>

2. Technical Data

2.1 Specifications

Model	BRPPD20H
Engine	Honda GX160
Power HP	5.5
Operating Weight (lb.)	250 LBS
Dethatching Width	20 inches

2.2 Dimensions In.

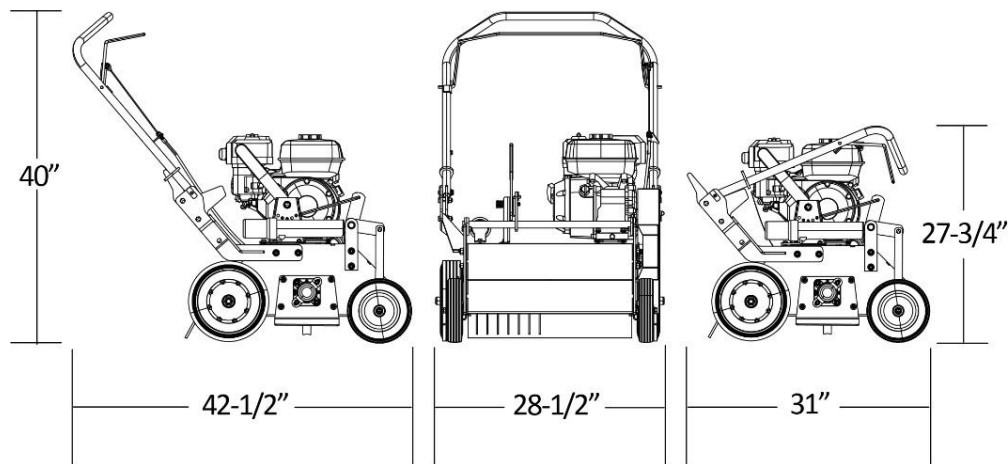

3. Operation

3.1 Operating Principle

The following instructions were compiled to provide you with information on how to obtain long and trouble-free use of this unit. Periodic maintenance of this unit is essential. Read the manual and the engine manual in their entirety and follow the instructions carefully. Failure to do so may injure yourself or a bystander.

3.2 Delivery Checks

Immediately on taking delivery of your new equipment and before putting it into service:

- Read the Operator's Manual completely – it could save a lot of time and unnecessary expense.
- Read the Engine Manual supplied.
- Check the general condition of the equipment – has it been damaged in shipment?
- Fill the engine with oil. Engine is shipped without oil and **MUST** be filled. See the engine manual for proper oil grade and quantity.
- Check the fuel level.
- Recommended lubrication and maintenance intervals are detailed in the Maintenance section.

3.3 Before Starting

The following Pre-start inspection must be performed before the start of each work session. If any fault is discovered, the Power Rake must not be used until the fault is rectified.

1. Thoroughly inspect the Power Rake for signs of damage. Check components are present and secure.
2. Check Flail blades and shaft for any worn or damaged parts.
3. Check the engine oil level.
4. Check for fuel or oil leaks.

NOTICE. Check the oil level in the engine. The warranty is VOID if the unit is run without oil.

3.4 Starting Gasoline Engine

1. Open the fuel tap by moving the fuel ON/OFF lever fully to the right.
2. If starting the engine from cold, set the choke ON by moving the choke lever fully to the left. When restarting a warm engine, the choke is usually not required. However, if the engine has cooled to a degree, partial choke may be required.
3. Turn the engine ON/OFF switch clockwise to the "I" (ON) position.
4. Set the throttle to approximately $\frac{1}{4}$ from idle by moving the throttle lever.
5. Ensure the bail is not pulled to the handlebar when starting.
6. Taking a firm hold of the control handle with one hand, grasp the recoil starter handle with the other. Pull the recoil starter until engine resistance is felt, then let the starter rope return.
7. Taking care not to pull the starter's rope fully out, pull the starter handle briskly.
8. Repeat until the engine starts.
9. Once the engine starts, gradually set the choke lever to the OFF position by moving it to the right.
10. Set the throttle lever to full.
11. If the engine fails to start after several attempts, follow the trouble-shooting guide in the engine manual.

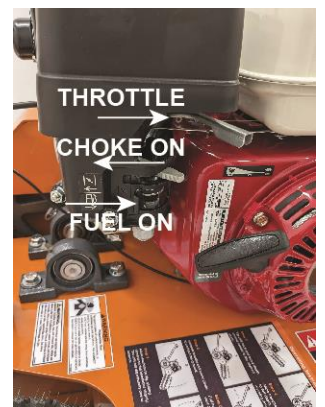

3.5 To Stop

- Push the throttle to the idle (closed) position.
- Turn the switch to the "O" (off) position.
- Close the fuel valve.

4. Operation

Use the dethatching height adjust lever to set the amount of ground engagement.

Throttle the engine to full throttle.

With a firm grasp of the dethatcher handle, pull the bail to the handlebar to start the blades rotating.

Push the handle to the right, against the spring to disengage the latch, and move the handle forward to lower the unit. Start with one hole and test to see the results. Push forward to see if the dethatching height is correct.



Use caution as the unit will pull forward as the blades engage the ground.

If further lowering is desired, adjust the unit further. Lower the unit one hole at a time, until the desired amount of dethatching is achieved. Re-engage the latch.

Use care not to lower it too far, or scalping the grass and stalling the engine could result.

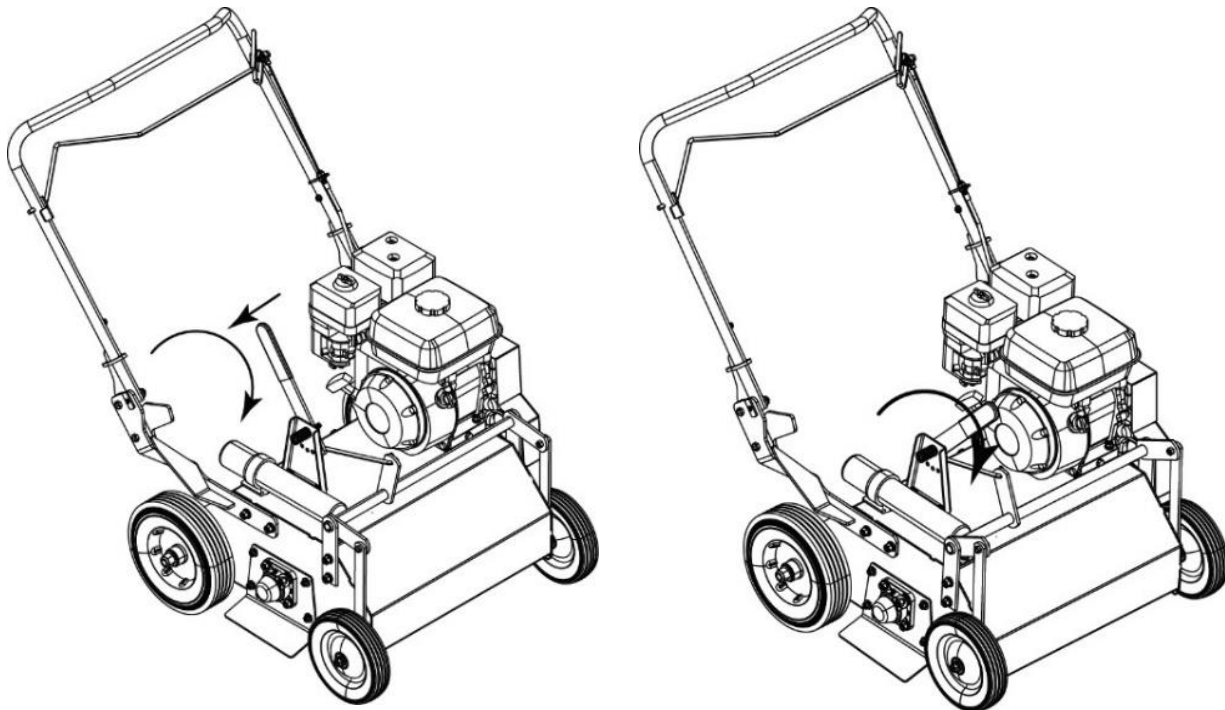

Push the dethatcher forward, at a slow to moderate walking speed.

Let the bail go to disengage the blades at the end of a row or anytime you stop.



Do not let go of the handle or leave the unit until the flail blades have come to a complete stop.

5. Parts

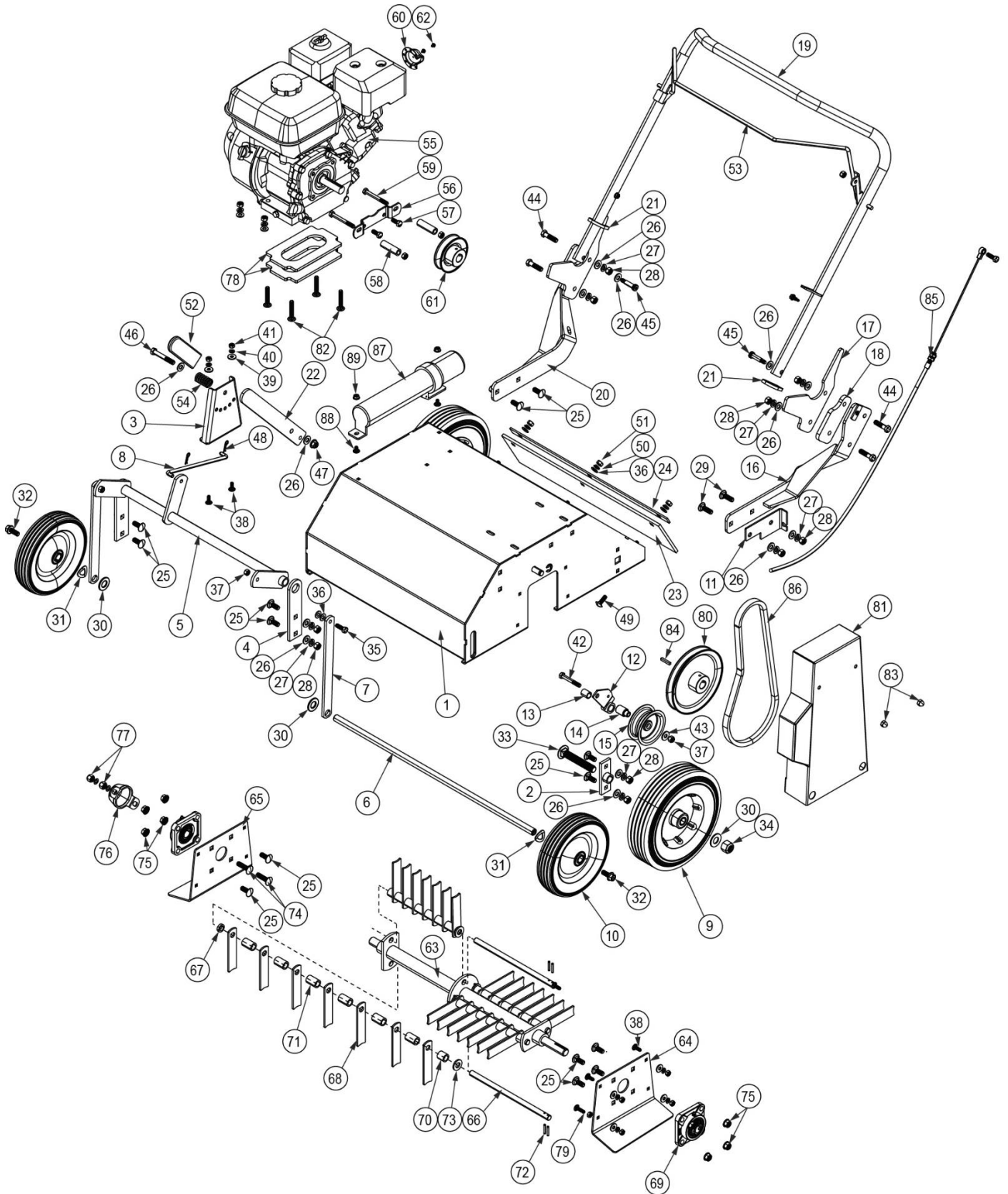



Ref#	Part Number	Description	Qty Per.	Ref#	Part Number	Description	Qty Per.
1	GPR111529	Main Frame Weldment	1	46	80055	Hex Head Bolt 3/8-16 x 2-1/2	1
2	GPR111530	Rear Axle Mount Weldment	2	47	GPR111566	Nylon Flange Lock Nut 3/8-16	1
3	GPR111531	Depth Adjustment Lock Plate	1	48	GPR111567	Hairpin Cotter Pin	2
4	GPR111532	Axle Linkage Pivot Plate	2	49	GPR111568	Carriage Bolt 5/16-18 x 1	3
5	GPR111533	Depth Linkage Weldment	1	50	82100.DOS	Lock Washer 5/16	3
6	GPR111534	Front Axle Shaft	1	51	GPR111569	Hex Nut 5/16-18	3
7	GPR111535	Axle Adjustment Linkage	2	52	GPR111570	Grip, Depth Handle	1
8	GPR111536	Height Adjustment Rod	1	53	GPR111571	Bail Weldment	1
9	GPR111537	Rear Wheel with Ball Bearing	2	54	GPR111572	Height Adjustment Spring	1
10	GPR111538	Front Wheel with Ball Bearing	2	55		Honda GX160 Engine	1
11	GPR111539	Clutch Cable Lower Mount Plate	1	56	GPR111573	Belt Guard Engine Mount	1
12	GPR111540	Idler Pulley Pivot Arm Weldment	1	57	GPR111574	Bolt, HHCS, M8-1.00 x 20mm	2
13	GPR111541	Bronze Sleeve Bearing	1	58	GPR111575	Belt Guide Bushing	2
14	GPR111542	Idler Pulley Offset Bushing	1	59	80045	Hex Head Bolt 5/16-18 x 2-3/4	2
15	GPR111543	Idler Pulley	1	60	MUF-18340	Exhaust Deflector	1
16	GPR111544	Handle Mount Weldment Left	1	61	GPR111576	Engine Pulley	1
17	GPR111545	Handle Lock/Rest	2	62	87437	Flange Head Screw #8 X 1/4	2
18	GPR111546	Handle Spacer	2	63	GPR111577	Flail Shaft Weldment	1
19	GPR111547	Handle Bar Weldment	1	64	GPR111578	Bearing Mount Plate Left	1
20	GPR111548	Handle Mount Weldment Right	1	65	GPR111579	Bearing Mount Plate Right	1
21	GPR111549	Handle Lock Ring	2	66	GPR111580	Flail Mount Shaft	4
22	GPR111550	Depth Adjustment Handle	1	67	GPR111581	Flail Spacer Short	4
23	GPR111551	Flap, Rear Guard	1	68	GPR111582	Flail Blade	28
24	GPR111552	Rear Guard Backup Plate	1	69	GPR111583	Bearing, Flail Shaft	2
25	GPR111553	Carriage Bolt 3/8-16 X 1	10	70	GPR111584	Flail Spacer Medium	4
26	80206.MAX	Flat Washer, 3/8	20	71	GPR111585	Flail Spacer Long	24
27	GPR111554	Lock Washer 3/8	16	72	GPR111586	Roll Pin 5/32 x 1	8
28	GPR111555	Hex nut 3/8-16	16	73	80207	Flat Washer SAE 1/2	4
29	GPR111556	Carriage Bolt 3/8-16 x 1-1/4	2	74	86035.MAX	Carriage Bolt 3/8-16 X 1-1/2	2
30	GPR111557	Flat Washer SAE, 5/8	4	75	86104.MAX	Serrated Flange Nut 3/8-16	8
31	GPR111558	Wavy Washer 5/830	2	76	GPR111587	Bearing Safety Cap	1
32	GPR111559	Flange Bolt 3/8-16 x 1	2	77	GPR111421	Nylon Locknut, 3/8-16	2
33	GPR111560	Carriage Bolt 5/8-11 x 4	2	78	GPR111589	Engine Spacer	2
34	GPR111561	Nylon Locknut 5/8-11	2	79	GPR111591	Carriage Bolt 1/4-20 x 1	2
35	80038	Hex Head Bolt 5/16-18 X 1	2	80	GPR111592	Pulley, Flail Shaft	1
36	80205	Flat Washer SAE, 5/16	7	81	GPR111593	Belt Cover Weldment	1
37	86101	Nylon Locknut 5/16-18	3	82	GPR111594	Carriage Bolt 5/16-18 x 2	4
38	80002.MAX	Carriage Bolt 1/4-20 x 3/4	8	83	GPR111595	Acorn Cap Nut 5/16-18	2
39	82085.DOS	Flat Washer 1/4	2	84	GPR111330	Key 3/16" SQ x 1-1/8	1
40	GPR111562	Lock Washer 1/4	2	85	GPR111596	Cable, Clutch	1
41	GPR111563	Hex Nut 1/4-20	2	86	GPR111597	Drive Belt	1
42	87282	Hex Head Bolt 5/16-18 X 2-1/4	1	87	790471	Manual Tube	1
43	80214	Flat Washer 5/16	1	88	GPR111588	Carriage Bolt 1/4-20 x 1/2	2
44	80053.MAX	Hex Head Bolt 3/8-16 X 1-1/2	4	89	GPR111590	Flange Nut 1/4-20	2
45	GPR111565	3/8 x 1 -1/8 SH Shoulder Bolt	2				

6. Maintenance

6.1 Periodic Maintenance Schedule.

Refer to the engine manufacturer's Operation Manual for additional information on engine maintenance. A copy of the engine Operation Manual was supplied with the machine when it shipped.

	Daily	At first 20 hours	Every 50 hours	Every 100 hours	Every 200 hours
Starting check	●				
Loose or lost screws	●				
Damage of any part	●				
V-belt check					●
Leakage of oil or fuel	●				
Engine oil check and replenishment	●				
Engine oil replacement		●		●	
Air cleaner			●		
Shaft Bearings - Grease		●	●		



These inspection intervals are for operation under normal conditions. Adjust your inspection intervals based on the number of hours the Power Rake is in use and working conditions. Dusty environments may necessitate more frequent service.

6.2 V-Belt

After approximately 200 hours of operation, remove the belt cover to check the v-belt condition. Loose or worn v-belts reduce the power transmission efficiency, causing weak raking and reduces the life of the belt itself.



NEVER attempt to check the v-belt with the engine running. Severe injury can occur if your hand gets caught between the belt and pulley.

6.3 Replacing the V-Belt

Remove the belt cover. Use care to keep fingers from being entangled in the belt pulley. Work belt off the large pulley and replace with new belt.



Whenever the raking operation becomes weak during normal operation, regardless of hours, check the v-belt immediately.

6.4 Air Cleaner

1. The air filter element should be cleaned often because a clogged air cleaner can cause poor engine starting, lack of power and shorten the life of the engine substantially.
2. To clean or replace the air filter, loosen the wingnut on the air filter housing (Fig. 1), remove the cover and take out the air filter cartridge. If you are only cleaning the air filter, blow compressed air through the filter cartridge from the inside, moving to cover the entire filter area.

6.5 Spark Plug

Check and clean or replace spark plugs regularly.

A fouled, dirty spark plug may cause hard starting and poor engine performance. Set spark plug gap to recommended clearance. Refer to engine manual.



The muffler and engine cylinder become very hot during operation and remain hot for some time after stopping the engine. You could suffer burns. Allow engine to cool before removing spark plug.

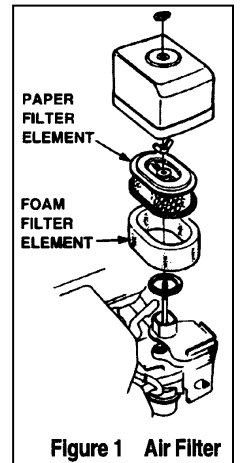

NOTICE: a loose spark plug can become very hot and may cause engine damage.

6.6 Transporting

1. Always shut off the engine when transporting machine.
2. Allow the unit to fully cool down.
3. Always shut off the fuel before transporting machine.
4. Secure the Dethatcher with suitable tie downs.



20195 South Diamond Lake Road, Suite 100 • Rogers, MN 55374
Toll-Free: 800-350-8739 • Website: GNEDI.com • Email: techservices@GNEDI.com

Dear Valued Customer:

The Brave product you just purchased is built with the finest material and craftsmanship. Use this product properly and enjoy the benefits from its high performance. By purchasing a Brave product, you show a desire for quality and durability. Like all mechanical equipment this unit requires a due amount of care. Treat this unit like the high-quality piece of machinery it is. Neglect and improper handling may impair its performance.

Thoroughly read the instructions and understand the operation before using your product. Always contact Brave Product Support at 1-800-350-8739 prior to having any service or warranty work performed, as some services performed by parties other than Brave approved service centers may void this warranty. This limited warranty is in lieu of any other warranty expressed or implied, written or oral and Brave assumes no other responsibility or liability outside that expressed within this limited warranty.

Limited Warranty for Brave Power Dethatcher:

Model BRPPD20H

	Consumer Warranty Period	Commercial Warranty Period
Weldments	2 years from date of purchase by user	2 years from date of purchase by user
Wear Parts	In addition to the normal warranty, Brave shall warrant some normal wear items from defects in material or workmanship for a period of 30 days from the date of purchase by user. Normal wear items covered under this warranty are limited to: High impact wear related components such as standard retention hardware for wear items, chains, bits, sprockets, bearings, belts and bushings, centrifugal clutch components such as shoes, springs, drum and rotor assembly, rotors, rubber drapes or flaps, drive and driven pulleys. Routine maintenance items such as lubricants, clutch adjustments, tune ups are not covered under warranty.	
Engines	The engine warranty is covered under the terms and conditions as outlined by the engine manufacturer’s warranty and is the sole responsibility of the engine manufacturer. Normal engine maintenance such as spark plugs, oil changes, air filters, adjustments, fuel system cleaning and obstruction due to build up is not covered by this Brave limited warranty.	

“Consumer use” means personal residential household use by a consumer. “Commercial use” means all other uses, including, but not limited to, use for commercial, income producing or rental purposes or when purchased by a business.

This limited warranty applies to the original purchaser of the equipment (verification of purchase, in the form of a receipt, is the responsibility of the buyer), is non-transferable, and covers parts and labor. Parts will be replaced or repaired at no charge, except when the equipment has failed due to lack of proper maintenance. If a part is no longer available, the part may be replaced with a similar part of equal function. Any misuse, abuse, alteration or improper installation or operations will void the warranty. Determining whether a part is to be replaced or repaired is the sole decision of Brave. Brave will not provide replacement of complete products due to defective parts. Any costs incurred due to replacement or repair of items outside of a Brave approved facility is the responsibility of the buyer and not covered under warranty. Transportation costs to and from the service center and/or service calls are the responsibility of the customer.

This limited warranty specifically excludes the following: failure of parts due to damage caused by accident, fire, flood, windstorm, acts of God, applications not approved by Brave in writing, corrosion caused by chemicals, use of replacement parts which do not conform to manufacturer’s specifications, damage related to rodent and/or insect infestation and damage caused by vandalism. Additional exclusions: loss of running time, inconvenience, loss of income, or loss of use, including any implied warranty of merchantability of fitness for a specific use. Also, outdoor power equipment needs periodic parts and service to perform well, and this limited warranty does not cover instances when normal use has exhausted the life of a component or the engine.

This limited warranty does not cover any personal injury or damage to surrounding property caused by failure of any part, misuse, or inability to use the product. Alteration of the product, including safety features, shall void this limited warranty.

Repair or replacement of parts does not extend the warranty period. This limited warranty gives you specific legal rights. You may also have other rights that vary by state. Please have model number, item number and serial number on hand prior to making a warranty claim or inquiry.

For products purchased on or after January 1, 2024