

KLUTCH®

Adjustable Sawhorse - Pair

Owner's Manual



WARNING: Read carefully and understand all ASSEMBLY AND OPERATION INSTRUCTIONS before operating. Failure to follow the safety rules and other basic safety precautions may result in serious personal injury.

Item# 6159522

READ & SAVE THESE INSTRUCTIONS

Thank you very much for choosing a Klutch product!

For future reference, please complete the owner's record below:

Serial Number/Lot Date Code (if applicable): _____

Purchase Date: _____

Save the receipt, warranty, and this manual. It is important that you read the entire manual to become familiar with this product before you begin using it.

This product is designed for certain applications only. Northern Tool & Equipment is not responsible for issues arising from modification or improper use of this product such as an application for which it was not designed. We strongly recommend that this product not be modified and/or used for any application other than that for which it was designed.

For technical questions, please call **1-800-222-5381**.

Table of Contents

Intended Use.....	4
Packaging Contents.....	4
Technical Specifications	4
Important Safety Information	4
Specific Operation Warnings	6
Before Each Use.....	6
Operating Instructions.....	7
After Each Use.....	9
Maintenance	9
Parts Diagram.....	10
Parts List.....	11
Replacement Parts	11
Limited Warranty	12

Intended Use

VENDOR: Describe how the product can be used, its functions, benefits, and examples.

Packaging Contents

- Sawhorse (2)
- Owner's Manual (1)

Technical Specifications

Max. Working Height	32 in.
Maximum Weight Capacity	2,600 lb per pair 1,300 lb per single

Important Safety Information

⚠WARNING

- Read and understand all instructions. Failure to follow all instructions may result in serious injury or property damage.
- The warnings, cautions, and instructions in this manual cannot cover all possible conditions or situations that could occur. Exercise common sense and caution when using this tool. Always be aware of the environment and ensure that the tool is used in a safe and responsible manner.
- Do not allow persons to operate or assemble the product until they have read this manual and have developed a thorough understanding of how it works.
- Do not modify this product in any way. Unauthorized modification may impair the function and/or safety and could affect the life of the product. There are specific applications for which the product was designed.
- Use the right tool for the job. DO NOT attempt to force small equipment to do the work of larger industrial equipment. There are certain applications for which this equipment was designed. It will be a safer experience and do the job better at the capacity for which it was intended. DO NOT use this equipment for a purpose for which it was not intended.
- Industrial or commercial applications must follow OSHA requirements.

⚠WARNING

PROP 65

- This product can expose you to chemicals including lead, which is known to the State of California to cause cancer. For more information, go to www.p65warnings.ca.gov.
- Some dust created by power sanding, sawing, grinding, drilling, and other construction activities contains chemicals known to the state of California to cause cancer, birth defects, or other

reproductive harm. Some examples of these chemicals are:

- - lead from lead-based paints,
 - - crystalline silica from bricks and cement and other masonry products, and
 - - arsenic and chromium from chemically-treated lumber.
- Your risk from these exposures varies depending on how often you do this type of work. To reduce your exposure to these chemicals, work in a well-ventilated area, and work with approved safety equipment, such as dust masks that are specially designed to filter out microscopic particles.
 - Handling power cords on corded products may expose you to lead, a chemical known to the state of California to cause cancer and birth defects or other reproductive harm. Wash your hands after handling.

⚠️WARNING

WORK AREA SAFETY

- Inspect the work area before each use. Keep work area clean, dry, free of clutter, and well-lit. Cluttered, wet, or dark work areas can result in injury. Using the product in confined work areas may put you dangerously close to cutting tools and rotating parts.
- Do not use the product where there is a risk of causing a fire or an explosion; e.g., in the presence of flammable liquids, gases, or dust. The product can create sparks, which may ignite the flammable liquids, gases, or dust.
- Do not allow the product to come into contact with an electrical source. The tool is not insulated and contact will cause electrical shock.
- Keep children and bystanders away from the work area while operating the tool. Do not allow children to handle the product.
- Be aware of all power lines, electrical circuits, water pipes, and other mechanical hazards in your work area. Some of these hazards may be hidden from your view and may cause personal injury and/or property damage if contacted.

⚠️WARNING

PERSONAL SAFETY

- Stay alert, watch what you are doing, and use common sense when operating the tool. Do not use the tool while you are tired or under the influence of drugs, alcohol, or medication. A moment of inattention while operating the tool may result in serious personal injury.
- Dress properly. Do not wear loose clothing, dangling objects, or jewelry. Keep your hair, clothing and gloves away from moving parts. Loose clothes, jewelry, or long hair can be caught in moving parts. Air vents on the tool often cover moving parts and should be avoided.
- Wear the proper personal protective equipment when necessary. Use ANSI Z87.1 compliant safety

goggles (not safety glasses) with side shields, or when needed, a face shield. Use a dust mask in dusty work conditions. Also use non-skid safety shoes, hardhat, gloves, dust collection systems, and hearing protection when appropriate. This applies to all persons in the work area.

- Do not overreach. Keep proper footing and balance at all times.

⚠CAUTION

PRODUCT USE AND CARE

- Do not force the product. Products are safer and do a better job when used in the manner for which they are designed. Plan your work and use the correct product for the job.
- Check for damaged parts before each use. Carefully check that the product will operate properly and perform its intended function. Replace damaged or worn parts immediately. Never operate the product with a damaged part.
- Store the product when it is not in use. Store it in a dry, secure place out of the reach of children. Inspect the tool for good working condition prior to storage and before re-use.
- Use only accessories that are recommended by the manufacturer for use with your product. Accessories that may be suitable for one product may create a risk of injury when used with another tool. Never use an accessory that has a lower operating speed or operating pressure than the tool itself.
- Keep guards in place and in working order. Never operate the product without the guards in place.

Specific Operation Warnings

⚠WARNING

- Inspect tool before use, looking for damaged, loose, and missing parts. If any problems are found, do not use tool until repaired.
- Be sure all lock pins and Latches are secure.
- Check that each Sawhorse is positioned level and straight, and all legs have solid contact with the floor.

Before Each Use

⚠WARNING

Inspect tool before use, looking for damaged, loose, and missing parts. If any problems are found, do not use tool until repaired.

Operating Instructions

⚠WARNING

Inspect tool before use, looking for damaged, loose, and missing parts. If any problems are found, do not use tool until repaired.

Set Up

1. Lay the Sawhorse on the ground.



2. Above the location labeled "Open 1st" press the release button and pull Legs all the way down.

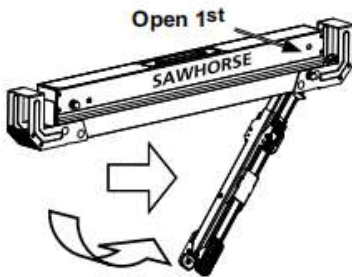

3. Separate Legs and push the Leg Locking Brace down flat.

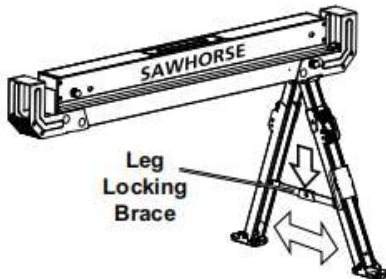

4. Above the location labeled "Close 1st" press the release button and pull Legs all the way down.

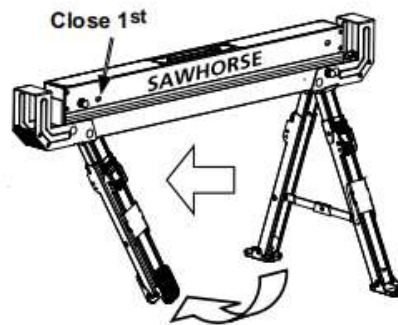

5. Separate Legs and push the Leg Locking Brace down flat, as done in Step 3.
6. Extend Legs as needed by pulling them down until the Latch is locked at the desired position. To retract legs, press the Latch button and pull Legs down slightly then push them up.

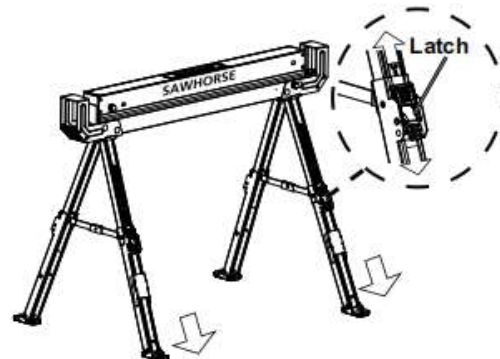

CAUTION! Be sure all lock pins and Latches are secure.

7. Carefully position the Sawhorse and place as needed.

8. When using two Sawhorses for a work table, use a 2 x 4 in the support arms to pair the two Sawhorses together. Fit each 2 x 4 end into the support arm openings at the end of the.

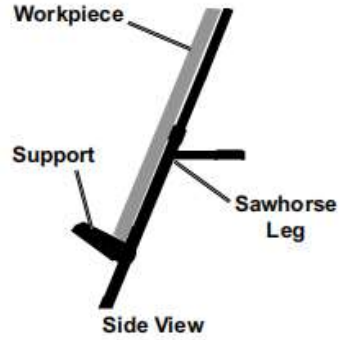
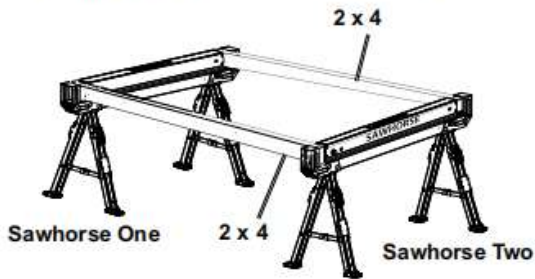

- b. Place Workpiece on Supports.

WARNING! TO AVOID SERIOUS INJURY: Check that each Sawhorse is positioned level and straight, and all legs have solid contact with the floor.

9. The side Supports may be pulled down and used to hold a Workpiece in place.

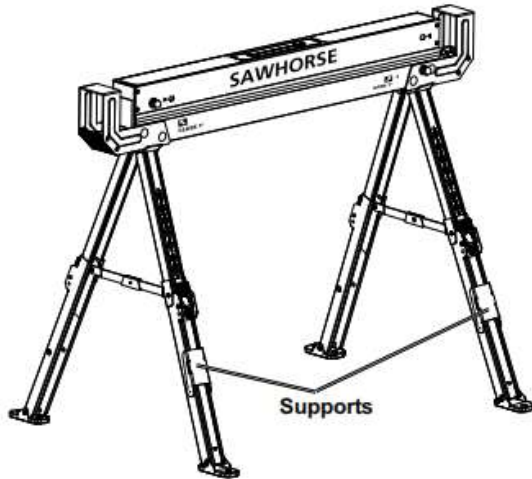

- a. Pull down Support on each Leg.

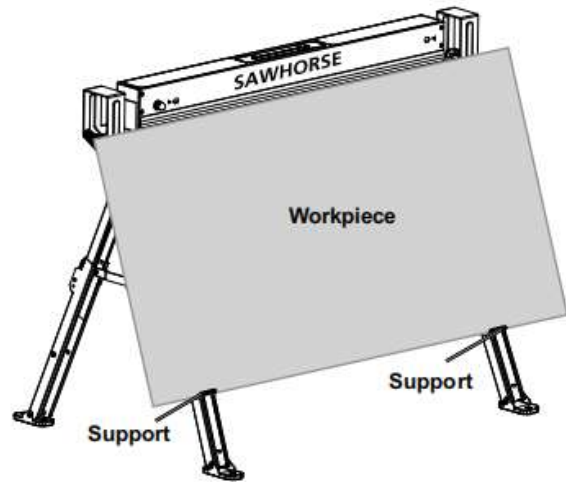

10. Before each use, confirm that:

- all Latches and lock pins are secure
- all Leg Locking Braces are secure
- all hardware is tight
- all legs have solid contact with the floor
- the Sawhorse is positioned level and straight.

Take Down

WARNING! TO PREVENT SERIOUS INJURY: Remove load before removing 2 x 4s or taking the Sawhorse down.

1. Reverse setup steps starting with the "Close 1st" Leg.

2. When fully collapsed, be sure all locking pins fully engage to secure the Sawhorse for transport.
3. Store Sawhorse in a clean, dry, safe location out of the reach of children.

After Each Use

⚠WARNING

Remove load before removing 2 x 4s or taking the Sawhorse down.

Maintenance

⚠WARNING

TO PREVENT SERIOUS INJURY FROM TOOL FAILURE:

Do not use damaged equipment. If damage is found, have the problem corrected before further use

1. BEFORE EACH USE, inspect the general condition of the tool. Check for:
 - loose hardware,
 - misalignment or binding of moving parts,
 - cracked or broken parts, and
 - any other condition that may affect its safe operation.
2. AFTER USE, wipe external surfaces of the tool with clean cloth.

Parts Diagram

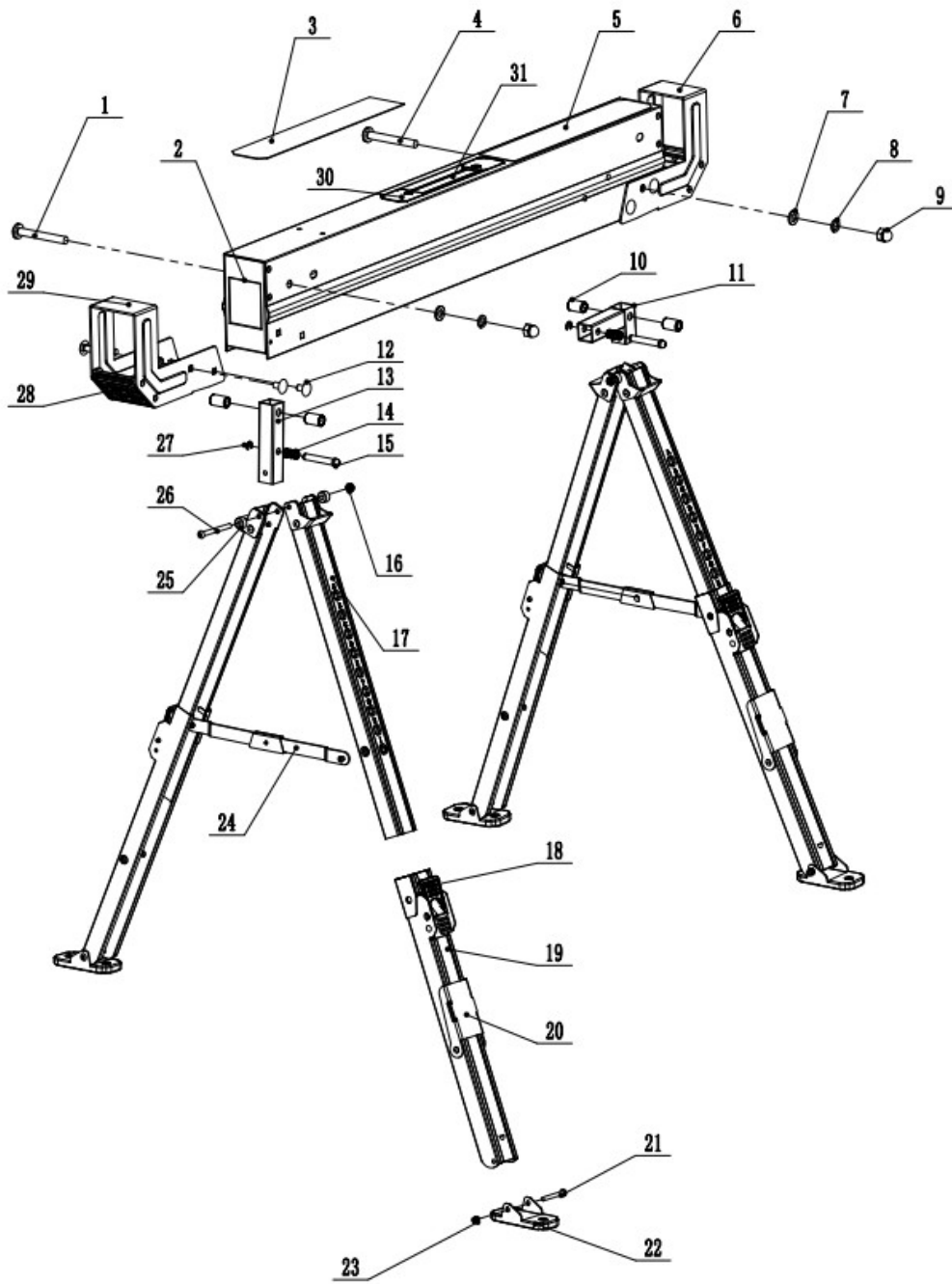

Parts List

Part	Description	Qty
1	Socket Head Screw	1
2	Steel Side Cover	2
3	Worktop Laminate	2
4	Socket Head Screw	1
5	Worktop	1
6	2 x 4 Bracket	1
7	Washer	2
8	Spring Washer	2
9	Cap Nut	2
10	Spacer Long	4
11	Leg Link Block 1	1
12	Carriage Bolt	8
13	Leg Link Block 2	1
14	Spring	2
15	Alignment Pin	2
16	Locknut	2

Part	Description	Qty
17	Inside Leg Set	4
18	Locking Handle	4
19	Outside Leg Set	4
20	Support	2
21	Bolt	4
22	Foot	4
23	Locknut	4
24	Leg Locking Brace	2
25	Spacer Short	4
26	Hex Socket Screw	2
27	Clip	2
28	Side Cover	2
29	2 x 4 Bracket 2	1
30	Handle Cover	2
31	Handle	1

Replacement Parts

- For replacement parts and technical questions, please call Customer Service at **1-800-222-5381**.
- Not all product components are available for replacement. The illustrations provided are a convenient reference to the location and position of parts in the assembly sequence.
- When ordering parts, the following information will be required: item description, item model number, item serial number/item lot date code, and the replacement part reference number.
- The distributor reserves the rights to make design changes and improvements to product lines and manuals without notice.

Limited Warranty

Northern Tool and Equipment Company, Inc. ("We" or "Us") warrants to the original purchaser only ("You" or "Your") that the Klutch product purchased will be free from material defects in both materials and workmanship, normal wear and tear excepted, for a period of **one year** from date of purchase. The foregoing warranty is valid only if the installation and use of the product is strictly in accordance with product instructions. There are no other warranties, express or implied, including the warranty of merchantability or fitness for a particular purpose. If the product does not comply with this limited warranty, Your sole and exclusive remedy is that We will, at our sole option and within a commercially reasonable time, either replace the product or product component without charge to You or refund the purchase price (less shipping). This limited warranty is not transferable.

Limitations on the Warranty

This limited warranty does not cover: (a) normal wear and tear; (b) damage through abuse, neglect, misuse, or as a result of any accident or in any other manner; (c) damage from misapplication, overloading, or improper installation; (d) improper maintenance and repair; and (e) product alteration in any manner by anyone other than Us, with the sole exception of alterations made pursuant to product instructions and in a workmanlike manner.

Obligations of Purchaser

You must retain Your product purchase receipt to verify date of purchase and that You are the original purchaser. To make a warranty claim, contact Us at 1-800-222-5381, identify the product by make and model number, and follow the claim instructions that will be provided. The product and the purchase receipt must be provided to Us in order to process Your warranty claim. Any returned product that is replaced or refunded by Us becomes our property. You will be responsible for return shipping costs or costs related to Your return visit to a retail store.

Remedy Limits

Product replacement or a refund of the purchase price is Your sole remedy under this limited warranty or any other warranty related to the product. We shall not be liable for: service or labor charges or damage to Your property incurred in removing or replacing the product; any damages, including, without limitation, damages to tangible personal property or personal injury, related to Your improper use, installation, or maintenance of the product or product component; or any indirect, incidental or consequential damages of any kind for any reason.

Assumption of Risk

You acknowledge and agree that any use of the product for any purpose other than the specified use(s) stated in the product instructions is at Your own risk.

Governing Law

This limited warranty gives You specific legal rights, and You also may have other rights which vary from state to state. Some states do not allow limitations or exclusions on implied warranties or incidental or consequential damages, so the above limitations may not apply to You. This limited warranty is governed by the laws of the State of Minnesota, without regard to rules pertaining to conflicts of law. The state courts located in Dakota County, Minnesota shall have exclusive jurisdiction for any disputes relating to this warranty.

KLUTCH[®]

Distributed by:

Northern Tool & Equipment Company, Inc.

Burnsville, Minnesota 55306

www.northerntool.com

Made in China