



12 Inch Compound Sliding Miter Saw

Owner's Manual



⚠ WARNING: Read carefully and understand all ASSEMBLY AND OPERATION INSTRUCTIONS before operating. Failure to follow the safety rules and other basic safety precautions may result in serious personal injury.

Item #61580

READ & SAVE THESE INSTRUCTIONS

Thank you very much for choosing an Ironton® product!

For future reference, please complete the owner's record below:

Serial Number/Lot Date Code: _____

Purchase Date: _____

Save the receipt, warranty, and this manual. It is important that you read the entire manual to become familiar with this product before you begin using it.

This miter saw is designed for certain applications only. Northern Tool and Equipment is not responsible for issues arising from modification or improper use of this product such as an application for which it was not designed. We strongly recommend that this product not be modified and/or used for any application other than that for which it was designed.

For technical questions, please call **1-800-222-5381**.

Table of Contents

Intended Use.....	4
Packaging Contents.....	4
Technical Specifications	4
Important Safety Information	4
Specific Operation Warnings	6
Grounding	7
Extension Cords.....	8
Main Parts of Miter Saw.....	9
Assembly Instructions.....	9
Before Each Use.....	14
Operating Instructions.....	14
After Each Use.....	20
Maintenance	20
Troubleshooting.....	21
Parts Diagram.....	22
Parts List.....	22
Replacement Parts	25
Limited Warranty.....	26

Intended Use

The Ironton 12 Inch Compound Sliding Miter Saw is a sliding compound miter saw designed to make smooth, accurate cuts in larger workpieces - up to 13-3/8 inches wide. The 12 inch blade on this sliding miter saw cuts thicker sections of wood. The precise miter system and machined-base fence support deliver increased cutting accuracy.

Packaging Contents

- Miter Saw
- 12in. 40T Saw Blade
- Dust Bag
- 2 Extension Bars
- Spanner
- Owner's Manual

Note: 4 bolts are needed for mounting and NOT included.

Technical Specifications

Property	Specification
Power	110V / 60Hz
Amperage	15A
HP	2.5 HP
Speed	3800 RPM
Blade	12" x 40T x 1" Arbor
Max Cutting Capacity	0° X 90° : 340 X 90 mm 0° X 45° : 340 X 48 mm 45° X 45° : 240 X 48 mm 45° X 90° : 240 X 90 mm

Important Safety Information

⚠ WARNING

- Read and understand all instructions. Failure to follow all instructions may result in serious injury or property damage.
- The warnings, cautions, and instructions in this manual cannot cover all possible conditions or situations that could occur. Exercise common sense and caution when using this tool. Always be aware of the environment and ensure that the tool is used in a safe and responsible manner.
- Do not allow persons to operate or assemble the product until they have read this manual and have developed a thorough understanding of how it works.
- Do not modify this saw in any way. Unauthorized modification may impair the function and/or safety and could affect the life of the product. There are specific applications for which the product was designed.
- Use the right tool for the job. DO NOT attempt to force small equipment to do the work of larger industrial equipment. There are certain applications for which this equipment was designed. This product will be safer and do a better job at the capacity for which it was intended. DO NOT use this equipment for a purpose for which it was not intended.
- Industrial or commercial applications must follow OSHA requirements.

⚠️WARNING

WORK AREA SAFETY

- Inspect the work area before each use. Keep work area clean, dry, free of clutter, and well-lit. Cluttered, wet, or dark work areas can result in injury. Using the product in confined work areas may put you dangerously close to cutting tools and rotating parts.
- Do not use the product where there is a risk of causing a fire or an explosion; e.g., in the presence of flammable liquids, gases, or dust. The product can create sparks, which may ignite the flammable liquids, gases, or dust.
- Do not allow the product to come into contact with an electrical source. The tool is not insulated and contact will cause electrical shock.
- Keep children and bystanders away from the work area while operating the tool. Do not allow children to handle the product.
- Be aware of all power lines, electrical circuits, water pipes, and other mechanical hazards in your work area. Some of these hazards may be hidden from your view and may cause personal injury and/or property damage if contacted.

⚠️WARNING

PERSONAL SAFETY

- Stay alert, watch what you are doing, and use common sense when operating the tool. Do not use the tool while you are tired or under the influence of drugs, alcohol, or medication. A moment of inattention while operating the tool may result in serious personal injury.
- Dress properly. Do not wear loose clothing, dangling objects, or jewelry. Keep your hair, clothing and gloves away from moving parts. Loose clothes, jewelry, or long hair can be caught in moving parts. Air vents on the tool often cover moving parts and should be avoided.
- Wear the proper personal protective equipment when necessary. Use ANSI Z87.1 compliant safety goggles (not safety glasses) with side shields, or when needed, a face shield. Use a dust mask in dusty work conditions. Also use non-skid safety shoes, hardhat, gloves, dust collection systems, and hearing protection when appropriate. This applies to all persons in the work area.
- Do not overreach. Keep proper footing and balance at all times.
- Remove keys or wrenches before connecting the tool to an air supply, power supply, or turning on the tool. A wrench or key that is left attached to a rotating part of the tool may cause personal injury.
- Secure the work with clamps or a vise instead of your hand when practical. This safety precaution allows for proper tool operation using both hands.

⚠️CAUTION

MITER SAW USE AND CARE

- Do not force the miter saw. Products are safer and do a better job when used in the manner for which they are designed. Plan your work, and use the correct product for the job.

- Check for damaged parts before each use. Carefully check that the product will operate properly and perform its intended function. Replace damaged or worn parts immediately. Never operate the product with a damaged part.
- Do not use a product with a malfunctioning switch. Any power tool that cannot be controlled with the power switch is dangerous and must be repaired by an authorized service representative before using.
- Disconnect the power/air supply from the product and place the switch in the locked or off position before making any adjustments, changing accessories, or storing the tool. Such preventive safety measures reduce the risk of starting the tool accidentally.
- Store the miter saw when it is not in use. Store it in a dry, secure place out of the reach of children. Inspect the tool for good working condition prior to storage and before re-use.
- Use only accessories that are recommended by the manufacturer for use with your product. Accessories that may be suitable for one product may create a risk of injury when used with another tool. Never use an accessory that has a lower operating speed or operating pressure than the tool itself.
- Keep guards in place and in working order. Never operate the product without the guards in place.
- Do not leave the miter saw running unattended.

Specific Operation Warnings

WARNING

- Cutting hazard. Keep hands away from cutting area. Never use your hands to remove sawdust, chips, or a workpiece near the saw blade or the cutting path of the saw.
- Always wear eye protection. Always wear protective gloves when handling saw blades.
- Wear NIOSH compliant dust masks or other respiratory protection during operation.
- Do not wear gloves, jewelry, or loose clothing.
- Do not use in the rain or in a damp location.
- Wait for the wheel to come to a complete stop before removing material.
- Only use a saw blade suitable for both your miter saw and your workpiece. The maximum permissible speed of your saw blade should be higher than the maximum rotational speed of the saw.
- Do not use a cracked or chipped blade.
- Operate in a well-ventilated area. Keep the floor area around the miter saw level and free of slippery substances or other tripping hazards.
- Only use accessories rated at least equal to the maximum speed marked on the tool.
- Do not modify the tool in any way.
- Always turn off and unplug the miter saw before making any adjustments or repair tasks. Never adjust the miter saw or the workpiece while the saw is running.

Grounding

⚠WARNING

- This machine must be grounded while in use to protect the operator from electrical shock. This unit is equipped with an electrical cord that has an equipment grounding conductor and a grounding plug. The plug **MUST** be plugged into a matching receptacle that is properly installed and grounded in accordance with ALL local codes and ordinances.
- **DO NOT MODIFY THE PROVIDED PLUG.** If it will not fit the receptacle, have the proper receptacle installed by a qualified electrician.
- **CHECK** with a qualified electrician or service person if you do not completely understand the grounding instructions, or if you are not sure the tool is properly grounded.

Grounded Tools: Tools with 3-Prong Plugs

Tools marked **Grounding Required** have a 3-wire cord and 3-prong grounding plug. The plug must be connected to a properly grounded outlet. If the tool should electrically malfunction or break down, grounding provides a low resistance path to carry electricity away from the user, reducing the risk of electric shock. (See Figure A.)

The grounding prong in the plug is connected through the green wire inside the cord to the grounding system in the tool. The green wire in the cord must be the only wire connected to the tool's grounding system and must never be attached to an electrically live terminal.

Your tool must be plugged into an appropriate outlet, properly installed and grounded in accordance with all codes and ordinances. The plug and outlet should look like those in the following illustration.

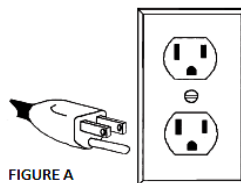

Double Insulated Tools: Tools with Two-Prong Plugs

Tools marked **Double Insulated** do not require grounding. They have a special double insulation system which satisfies OSHA requirements and complies with the applicable standards of Underwriters Laboratories, Inc., the Canadian Standard Association, and the National Electrical Code. (See Figure B.)

Double insulated tools may be used in either of the 120 volt outlets shown in the following illustration.

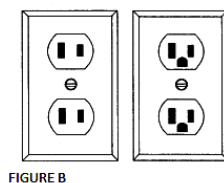

Extension Cords

⚠WARNING

- **USE A PROPER EXTENSION CORD.** Make sure your extension cord is in good condition. When using an extension cord, be sure to use one heavy enough to carry the current your product will draw. An undersized cord will cause a drop in line voltage, resulting in loss of power and cause overheating.
- Be sure your extension cord is properly wired and in good condition. Always replace a damaged extension cord or have it repaired by a qualified person before using it. Protect your extension cords from sharp objects, excessive heat and damp or wet areas.
- Grounded tools require a 3-wire extension cord. Double Insulated tools can use either a 2- or 3-wire extension cord.
- As the distance from the supply outlet increases, you must use a heavier gauge extension cord. Using extension cords with inadequately sized wire causes a serious drop in voltage, resulting in loss of power and possible tool damage.
- The smaller the wire's gauge number, the greater the capacity of the cord. For example, a 14-gauge cord can carry a higher current than a 16-gauge cord. Minimum extension cord wire size is shown in the following table:

Minimum Wire Size Of Extension Cords				
Nameplate AMPS	Cord Length			
	25'	50'	100'	150'
0-6	18 AWG	16 AWG	16 AWG	14 AWG
6-10	18 AWG	16 AWG	14 AWG	12 AWG
10-12	16 AWG	16 AWG	14 AWG	12 AWG
12-16	14 AWG	12 AWG	NOT RECOMMENDED	

- When using more than one extension cord to make up the total length, make sure each cord contains at least the minimum wire size required.
- If you are using one extension cord for more than one tool, add the nameplate amperes and use the sum to determine the required minimum cord size.
- If you are using an extension cord outdoors, make sure it is marked with the suffix **W-A** (**W** in Canada) to indicate it is acceptable for outdoor use.
- Make sure your extension cord is properly wired and in good electrical condition. Always replace a damaged extension cord or have it repaired by a qualified electrician before using it.
- Protect your extension cords from sharp objects, excessive heat, and damp or wet areas.

Main Parts of Miter Saw

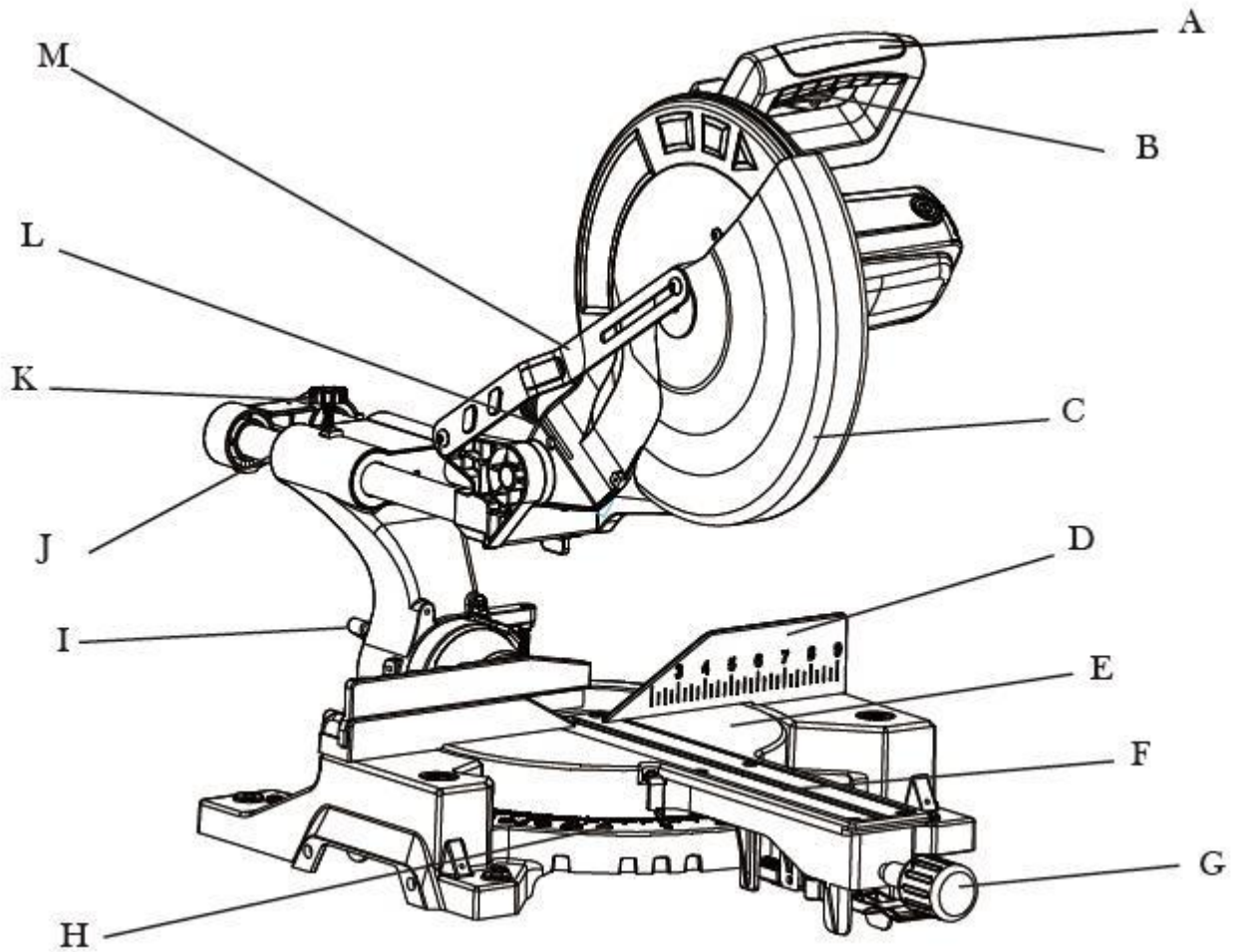

Reference	Subassembly
A	Operating Handle
B	ON/OFF Switch
C	Blade Guard
D	Fence
E	Miter Table
F	Table Insert
G	Miter Table Lock
H	Miter Scale
I	Bevel Lock Knob
J	Slide Bar
K	Slide Lock Knob
L	Dust Extraction Port
M	Guard Retraction Arm

Assembly Instructions

⚠WARNING

- Make sure that the mounting surface is level. Uneven surfaces can cause binding and inaccurate

sawing.

- Be sure to tighten the miter table lock before making a cut. Failure to do so can cause the table to move during the cut, resulting in serious personal injury.

Bench Mounting

The saw base has holes in each corner to facilitate bench mounting (FIGURE 1).

1. Mount and attach the saw to a level, horizontal bench or worktable using four bolts (not included).
2. If desired, you can mount the saw to a piece of 1/2" or thicker plywood which can then be clamped to your work support or moved to other job sites and reclamped.



FIGURE 1

Release Knob

The release knob is provided for holding the saw arm in place during transportation or storage. The saw must not be used while the release knob is locking the head down. To release the saw arm, push down on the top of the saw arm, pull on the release knob (FIGURE 2), rotate it 45° and let go, and then slowly raise the saw arm.

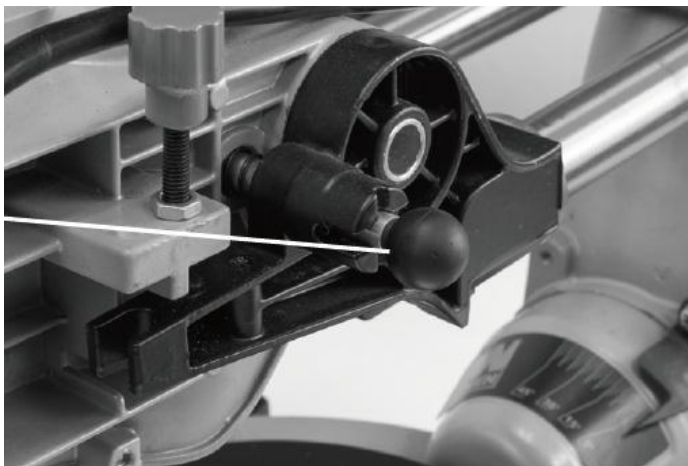

FIGURE 2

Slide Lock Knob

When tightened, the slide lock knob (FIGURE 3) prevents the saw head from sliding along the slide bar. Tighten the slide lock knob during transportation to prevent accidents.

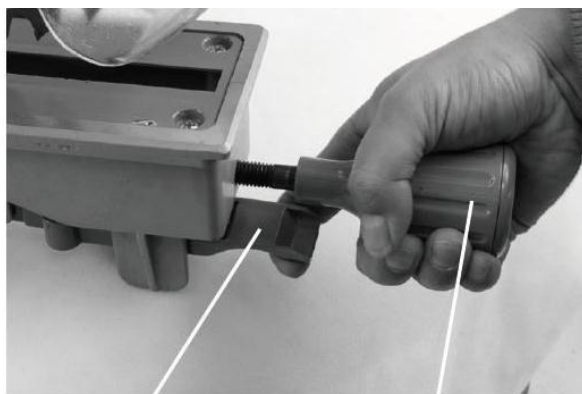

FIGURE 3

Miter Table Lock

The miter table lock is used to lock the table at the desired miter angle (FIGURE 4). The miter saw cuts from 0° to 45° both left and right. To adjust the angle, loosen the miter table lock, hold the miter release handle, and rotate to the desired miter angle. Relock the table in place by tightening the miter table lock.

The miter table features positive click stops at 0°, 15°, 22.5°, 31.6°, and 45° in both directions for quick setting of common miter angles.



(Miter Release Handle) (Miter Table Lock)

FIGURE 4

Bevel Lock

The bevel lock is used to set the blade at the desired bevel angle (FIGURE 5). The miter saw bevels from 0° to 45° left only. Hold the operating handle and loosen the bevel lock to set the bevel angle. Tighten the bevel lock.

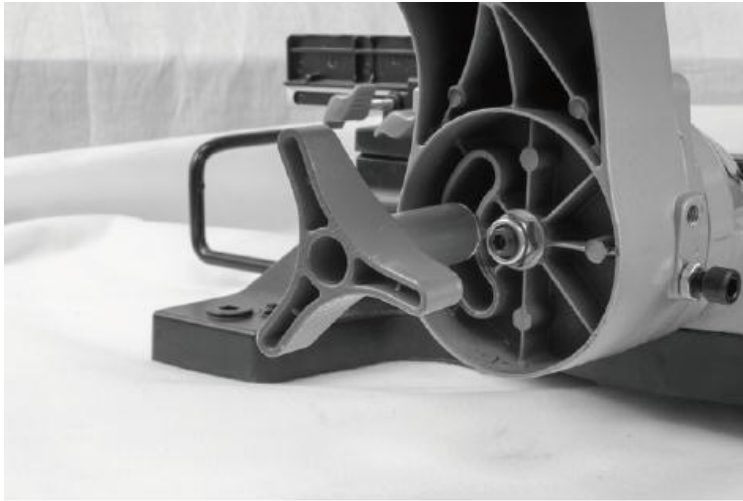

FIGURE 5

Hold Down Clamp Assembly

The hold down clamp assembly can be mounted to the fence on either side of the saw blade depending on what suits the task at hand. Use the clamp assembly lock at the back of the fence to secure the clamp assembly in position (FIGURE 6). Check that the clamp doesn't interfere with the entire path of the saw travel before operation.

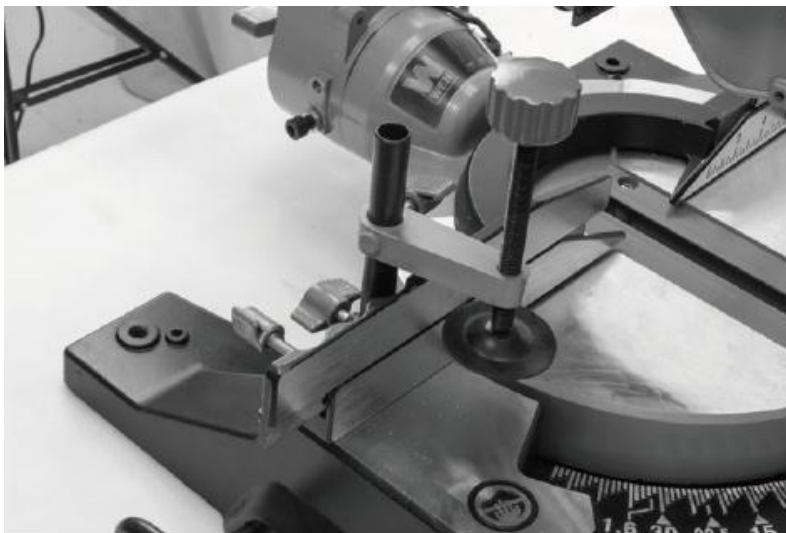

FIGURE 6

Spindle Lock Button

The spindle lock button prevents the blade in the saw from rotating (FIGURE 7). Press and hold the spindle lock button while installing, changing, or removing the blade.

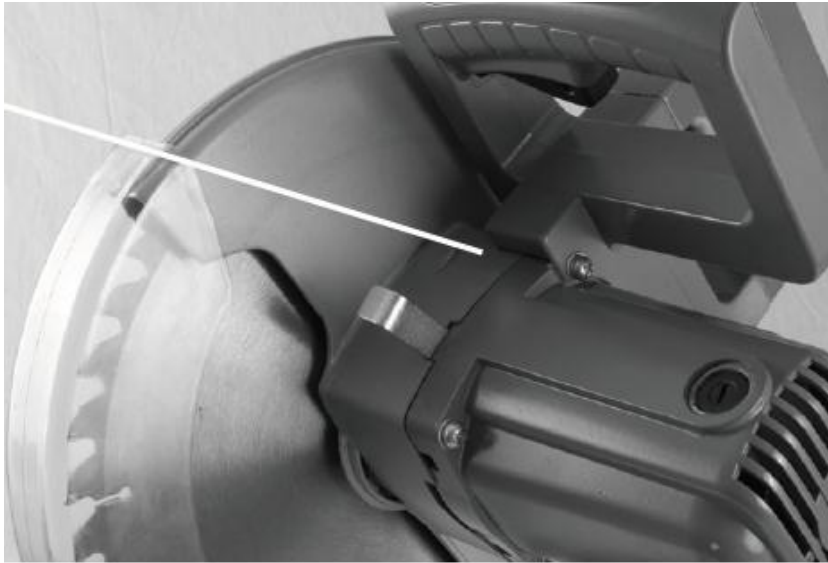

FIGURE 7

Rotating Lower Blade Guard

The rotating lower blade guard provides protection from both sides of the blade (FIGURE 8). It retracts over the upper blade guard as the saw is lowered onto the workpiece.

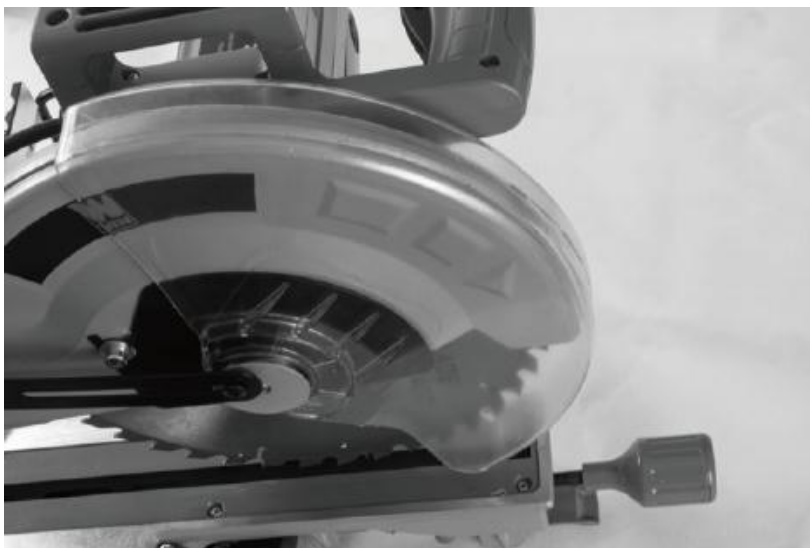

FIGURE 8

Attaching the Material Support Arms

The material support arms help to support the material when working with long workpieces. There are two location holes for support bars on either side of the table. Loosen the lock screws with the hex key. Ensure the side bars are fully inserted before using them to support the workpiece (FIGURE 9).

The side support bar locking screws must be tightened to secure the support bars in position.



FIGURE 9

(Lock Screws)

Before Each Use

⚠WARNING

- Securely bolt the miter saw onto a miter saw stand or a workbench.
- Examine the miter saw for any damaged or missing parts. Replace or repair damaged parts before operation. Periodically check that all nuts, bolts, and other fasteners are properly tightened.
- Do not use the miter saw unless all guards are in place.

Operating Instructions

⚠WARNING

- Cutting hazard. Keep hands away from cutting area. Never use your hands to remove sawdust, chips, or a workpiece near the saw blade or the cutting path of the saw.
- Always wear eye protection. Always wear protective gloves when handling saw blades.
- Wear NIOSH compliant dust masks or other respiratory protection during operation.
- Do not wear gloves, jewelry, or loose clothing.

- Do not use in the rain or in a damp location.
- Wait for the wheel to come to a complete stop before removing material.
- Only use a saw blade suitable for both your miter saw and your workpiece. The maximum permissible speed of your saw blade should be higher than the maximum rotational speed of the saw.
- Do not use a cracked or chipped blade.
- Operate in a well-ventilated area. Keep the floor area around the miter saw level and free of slippery substances or other tripping hazards.
- Always position the workpiece on the miter table and firmly against the fence. Never perform any operation freehand. Always use a clamp to support the workpiece whenever possible.
- When cutting round workpieces, use clamps on both sides of the table to prevent the workpiece from turning. Position the convex (curved) side against the fence.
- Always support long workpieces properly using stands or roller tables.
- Never hold a workpiece that is too small to be clamped, as it can be launched away and cause injury. Use proper support and guides to secure the small workpiece.
- Make sure the path of the saw blade is clear of obstruction. Before turning on the miter saw, do a dry run and make sure that the saw blade does not touch anything other than the workpiece during its entire line of travel.
- Always stand to one side when operating the saw. Never have any part of the body in line with the path of the saw.
- Do not use the saw to cut metal or masonry.
- Turn on the miter saw and let it reach full speed, then slowly lower the saw into the workpiece. This will help produce safer and cleaner cuts. Release the switch and allow the saw blade to stop rotating before raising the blade out of the workpiece.
- During slide cutting, always push the saw blade away from you. Do not pull the saw toward you.
- Never cut more than one piece at a time. Do not stack workpieces together.
- Only use accessories rated at least equal to the maximum speed marked on the tool.
- Do not modify the tool in any way.
- Always turn off and unplug the miter saw before making any adjustments or repair tasks. Never adjust the miter saw or the workpiece while the saw is running.

Setting the Blade Square with the Table

1. Make sure that the power cord is removed from the power source.
2. Push the saw arm down to its lowest position and engage the release knob (FIGURE 2).
3. Loosen the miter table lock (FIGURE 10).

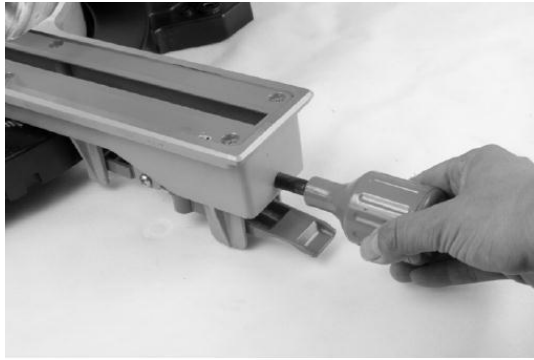

FIGURE 10

4. Lift the miter release handle and rotate the miter table until the pointer is positioned at 0°. Tighten the miter table lock.
5. Loosen the bevel lock (FIGURE 11) and set the saw arm at 0° bevel (leaving the blade at 90° to the miter table). Tighten the bevel lock.



FIGURE 11

6. Place a set square against the table and the flat part of the blade (FIGURE 12). Make sure that the square contacts the flat part of the saw blade, not the teeth.



FIGURE 12

7. Rotate the blade by hand and check the blade-to-table alignment at several points. Wear work gloves when handling the saw blade.
8. The edge of the set square and the saw blade should be parallel. If the saw blade angles away from the set square, adjust as follows.
 - a) Use a 13 mm wrench or adjustable wrench to loosen the lock nut securing the 0° bevel adjustment screw (FIGURE 13).



FIGURE 13

- b) Adjust the 0° bevel adjustment screw (FIGURE 13) to bring the saw blade into alignment with the square.
 - c) Loosen the screw holding the pointer of the bevel scale and adjust the position of the pointer so that it accurately indicates zero on the scale (FIGURE 14). Retighten the screw.



FIGURE 14

- d) Retighten the bevel lock (FIGURE 11) and the lock nut securing the 0° bevel adjustment screw (FIGURE 13).

Cross-Cutting without Slide Action

When cutting a narrow piece of wood, it is not necessary to use the slide mechanism. In these cases, ensure that the slide lock knob is screwed down to prevent the saw arm from sliding (FIGURE 3). A cross cut is made by cutting across the grain of the work piece. A 90° crosscut is made with the miter table set at 0°. Miter cross cuts are made with the table set at an angle other than zero.

1. Pull on the release knob (FIGURE 2) and lift the saw arm to its full height.
2. Loosen the miter lock (FIGURE 10).
3. Rotate the miter table until the pointer aligns with the desired angle.
4. Retighten the miter lock.
5. Place the workpiece flat on the table with one edge securely against the fence. If the board is warped, place the convex side against the fence. If the concave side is placed against the fence, the board could break and jam the blade.
6. When cutting long pieces of timber, support the opposite end of the timber with either side support arms, a roller stand, a work surface level with the saw's table, or a combination of the three.
7. Use the clamp assembly to secure the workpiece wherever possible.
8. It is possible to remove the clamp assembly by loosening the clamp assembly lock and moving it to the other side of the table. Make sure the clamp assembly lock is tight before using the clamp (FIGURE 21).



FIGURE 21

9. Before turning on the saw, perform a dry run of the cutting operation to check that there are no problems.
10. Hold the operating handle firmly and squeeze the switch trigger. Allow the blade to reach maximum speed and slowly lower the blade into and through the workpiece.
11. Release the switch trigger and allow the saw blade to stop rotating before raising the blade out of the workpiece. Wait until the blade stops before removing the workpiece.

Cross-Cutting with Slide Action

When cutting wide work pieces, first unscrew the slide lock knob (FIGURE 3).

1. Pull on the release knob (FIGURE 2), raise the saw arm to its highest position, and slide it toward you.
2. Hold the handle firmly and squeeze the switch trigger. Allow the blade to reach maximum speed.
3. Slowly lower the blade into the workpiece while pushing it away from you until the workpiece is cut.
4. Release the switch trigger and allow the saw blade to stop rotating before raising the blade out of the workpiece. Wait until the blade stops before removing the workpiece.

Bevel Cut

A bevel cut is made by cutting across the grain of the workpiece with the blade set an angle to the miter table. The miter table is set to the zero degree position while the bevel angle is set to between 0° and 45° (FIGURE 23). Use the slide action when cutting wide workpieces.

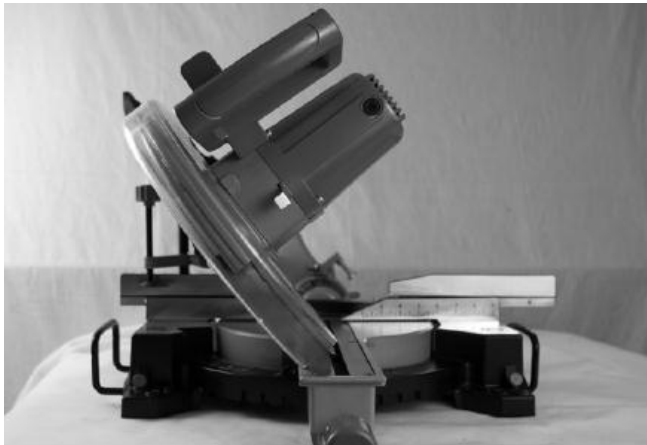

FIGURE 23

1. Pull on the release knob (FIGURE 2) and lift the saw arm to its full height.
2. Loosen the miter lock (FIGURE 10).
3. Rotate the miter table until the pointer aligns with zero on the miter scale. Retighten the miter lock.
4. Loosen the bevel lock (FIGURE 11). Move the saw arm to the desired bevel angle (between 0° and 45°). Tighten the bevel lock.
5. Place the workpiece flat on the table with one edge securely against the fence. If the board is warped, place the convex side against the fence. If the concave side is placed against the fence, the board could break and jam the blade.
6. When cutting long pieces of timber, support the opposite end of the timber with the sidebars, a roller stand, or a work surface that is level with the saw table.
7. Use the clamp assembly to secure the workpiece wherever possible.
8. It is possible to remove the clamp assembly by loosening the clamp assembly lock and moving it to the other side of the table. Make sure the clamp assembly lock is tight before using the clamp.

9. Before turning on the saw, perform a dry run of the cutting operation to check that there are no problems.
10. Hold the operating handle firmly and squeeze the switch trigger. Allow the blade to reach maximum speed.
11. Slowly lower the blade into and through the workpiece.
12. Once the cut has been made, release the switch trigger and allow the saw blade to stop rotating before raising the blade out of the workpiece. Wait until the blade stops before removing the workpiece.

After Each Use

⚠WARNING

- Always ensure that the saw is switched off and the plug is removed from the outlet before making any adjustments or conducting maintenance procedures.
- Keep away from children.

Maintenance

Maintain the saw by adopting a program of conscientious repair and maintenance in accordance with the following recommended procedures. It is recommended that the general condition of any tool be examined before it is used. Keep your tool in good repair. Keep all cutting tools sharp and clean. Properly maintained cutting tools with sharp cutting edges are less likely to bind and are easier to control. Keep handles dry, clean, and free from oil and grease. The following chart is based on a normal operation schedule.

Maintenance Interval	Maintenance Point
Daily before operating	<p>Keep the vents clear of dust and debris.</p> <p>Inspect the cord and have it replaced by an authorized technician.</p>
After the 60 hours of use	<p>Check the brushes and replace as needed.</p> <p>If you replace the brushes, run the saw without load for 15 minutes to seat the brushes properly.</p>

Troubleshooting

Use the table below to troubleshoot problems before contacting service personnel or your local dealer. If the problem continues after troubleshooting, call your local dealer for assistance.

Failure	Possible Cause	Corrective Action
Tool operates slowly	Excess pressure applied to workpiece.	Decrease pressure
	2. Power being reduced by long or small diameter extension cord.	Eliminate use of extension cord
Performance decreases over time	Brushes worn or damaged.	Have qualified technician replace brushes
Overheating.	Forcing tool to work too fast	Allow tool to work at its own rate.
	Blocked motor housing vents	Wear ANSI-approved safety goggles and NIOSH-approved dust mask/respirator while blowing dust out of motor using compressed air.

Parts Diagram

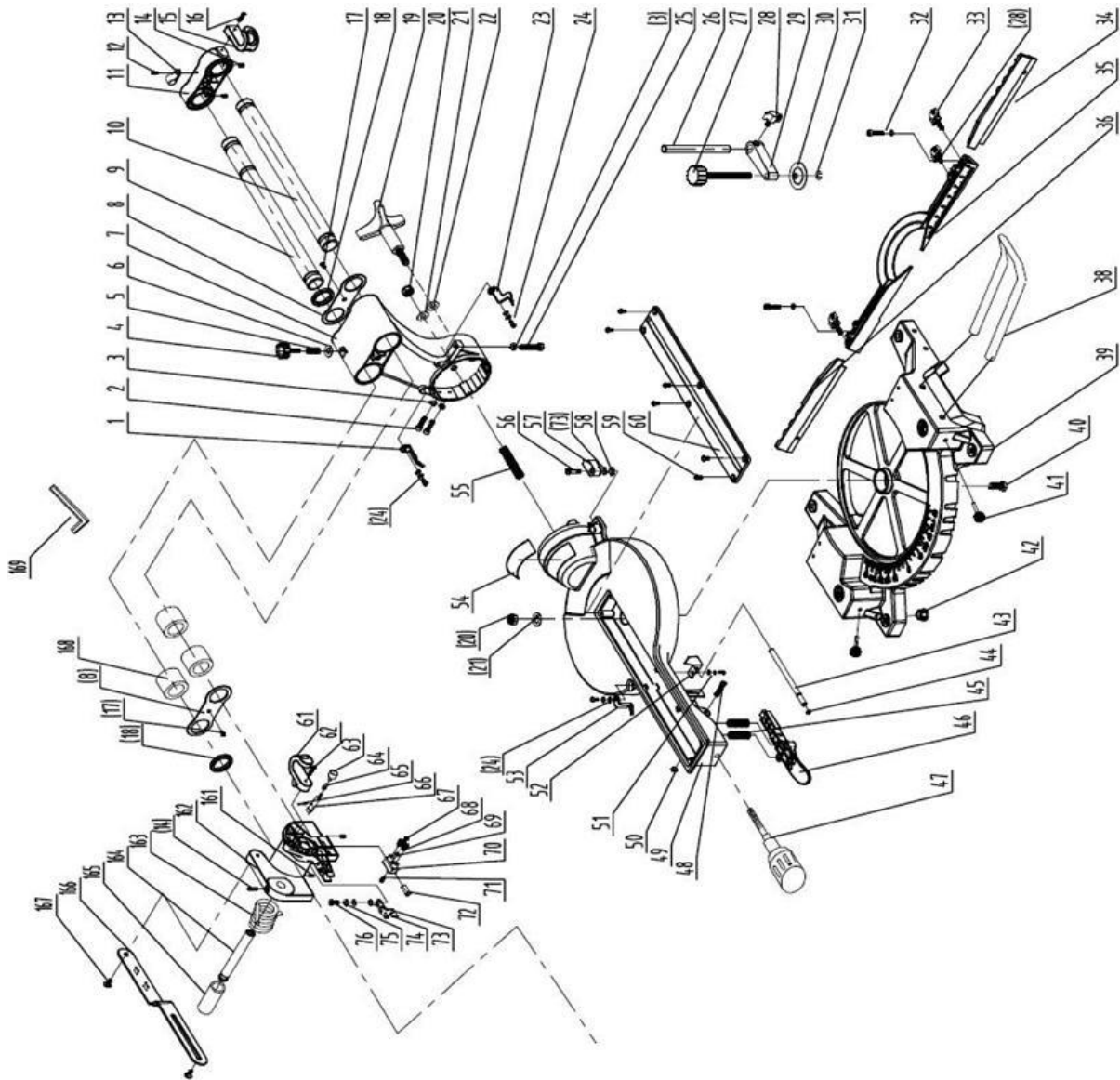

Parts List

Part Number	Part Description	Quantity
1	Left Bevel Gauge	1
2	Hex Screw M8	2
3	Hex Nut M8	3
4	Slide Lock Knob	1
5	Lock Knob Spring	1
6	Flat Washer	1
7	Bevel Arm	1
8	Bearing Mount	2
9	Left Rod	1
10	Right Rod	1
11	Rear Stop	1
12	Bolt	1
13	Wire Clip	2
14	Bolt M6	2

Part Number	Part Description	Quantity
15	back reel	1
16	Screw ST4	1
17	Screw M5	3
18	Gasket	2
19	Bevel Locking Knob	1
20	Lock Nut M10	2
21	Washer M10	2
22	Washer M10	1
23	Right Bevel Gauge	1
24	Screw, Flat Washer, Spring Washer M5	3
25	Bolt M8	1
26	Clamping Bar	1
27	Clamping Knob	1
28	Knob	3
29	Clam Bracket	1
30	Clamp	1
31	Washer	1
32	Hex Screw with Washer M6	2
33	Double Leaf Knob Assembly	2
34	Right Slide Fence	1
35	Fence	1
36	Left Sliding Fence	1
38	Support Arm	2
39	Base	1
40	Bolt	1
41	Knob	3
42	Rubber Feet	4
43	Locking Bar	1
44	seal ring $\phi 5 \times \phi 1.8$	1
45	Spring	2
46	Miter Release Handle	1
47	Miter Lock Knob	1
48	Bolt M6	1
49	Table	1
50	Nut	1
51	Screw and Washer M5	1
52	Spring Card	1
53	Pointer	1
54	Bevel Angle Label	1
55	Bolt M10	1
56	Set Screw	1
57	Double Bevel Block	1
58	Hex Nut M8	2
59	Screw M5	6
60	Table Insert	1
61	front reel	1
62	Screw M4	1
63	Chop Lock Knob	1
64	Lock Spring	1
65	Lock Pin	1
66	Locking Pin Spring	1
73	Wavy Spring Washer	3
74	Limiter	1
75	Flat Washer M6	1

Part Number	Part Description	Quantity
76	Step Screw M7	1
77	Dust Bag	1
78	Bolt M5	2
79	Dust Port	1
80	Wire Clip	1
81	Bolt ST4	6
82	Bolt M4	1
83	Bolt M6	2
84	Small Pulley	1
85	Bolt and Washer M6	4
86	Set Screw M6	1
87	Hex Nut M5	1
88	Housing Side Cover	1
89	Bolt M5	1
90	Big Pulley	1
91	Gear Locking Pin	1
92	Gear Locking Clamp	1
93	Seal Ring	1
94	Gear Locking Spring	1
95	Belt	1
96	Belt Housing	1
97	Bolt M5	3
98	Bolt Spring Washer and Washer M5	4
99	Bearing 6900-2RS	2
100	Gear Shaft	1
101	Bearing 6001-2RS	1
102	Gear	1
103	Washer M17	1
104	Output Shaft	1
105	Key 4x13	1
106	Bearing 6904-2RS	1
107	Front Cover	1
108	Inner Flange	1
109	Blade Bushing Block	1
111	Outer Flange	1
112	Bolt M8	1
113	Housing	1
114	Housing Label	1
115	Blade Guard Bracket	1
116	Washer and Set Screw M8	1
117	Blade Guard	1
118	Blade Guard Wheel	2
119	Lock Washer M5	2
120	Lock Nut M5	1
121	Outer Blade Guard Cover	1
122	Bolt ST4	3
123	Coil Spring	1
124	Nut M5	1
125	Blade Guard Plate	1
126	Washer	1
127	Screw M5	1
128	Motor Mount	1
129	Fan Shroud	1
130	Bearing 6202-2RZ	1

Part Number	Part Description	Quantity
131	Washer M15	1
132	Rotor	1
133	Motor Housing with Logo	1
134	Brush Holder	2
135	Carbon Brush	2
136	Brush Holder Cap	2
137	Motor Plate	1
138	Bolt ST6	4
139	Stator	1
140	Bearing 6000-2RZ	1
141	Bolt ST4	2
142	Switch	1
143	Switch Spring	1
144	Switch Button	1
145	Safety Lock	1
146	Left Safety Button	1
147	Safety Lock Pin	2
148	Torsional Spring	1
149	Upper Handle Housing	1
150	Lifting Handle	1
151	Bolt ST6	2
152	Cable Sheath	1
153	Cable	1
154	Bolt M5	2
155	Transformer	1
156	Bolt ST4	2
157	Wire Clamp	1
158	Lower Handle Housing	1
159	Wire Terminal	2
160	Right Safety Switch	1
161	Hex Screw M6	2
162	Mounting Bracket	1
163	Torsional Spring	1
164	Pin	1
165	Plastic Sleeve	1
166	Bushing	1
167	Bolt M5	2
168	Bearing LM30UU	3
169	Allen Wrench	1
170	Bolt M5	1

Replacement Parts

- For replacement parts and technical questions, please call Customer Service at **1-800-222-5381**.
- Not all product components are available for replacement. The illustrations provided are a convenient reference to the location and position of parts in the assembly sequence.
- When ordering parts, the following information will be required: item description, item model number, item serial number/item lot date code, and the replacement part reference number.
- The distributor reserves the rights to make design changes and improvements to product lines and manuals without notice.

Limited Warranty

Northern Tool and Equipment Company, Inc. ("We" or "Us") warrants to the original purchaser only ("You" or "Your") that the Ironton product purchased will be free from material defects in both materials and workmanship, normal wear and tear excepted, for a period of **one year** from date of purchase. The foregoing warranty is valid only if the installation and use of the product is strictly in accordance with product instructions. There are no other warranties, express or implied, including the warranty of merchantability or fitness for a particular purpose. If the product does not comply with this limited warranty, Your sole and exclusive remedy is that We will, at our sole option and within a commercially reasonable time, either replace the product or product component without charge to You or refund the purchase price (less shipping). This limited warranty is not transferable.

Limitations on the Warranty

This limited warranty does not cover: (a) normal wear and tear; (b) damage through abuse, neglect, misuse, or as a result of any accident or in any other manner; (c) damage from misapplication, overloading, or improper installation; (d) improper maintenance and repair; and (e) product alteration in any manner by anyone other than Us, with the sole exception of alterations made pursuant to product instructions and in a workmanlike manner.

Obligations of Purchaser

You must retain Your product purchase receipt to verify date of purchase and that You are the original purchaser. To make a warranty claim, contact Us at 1-800-222-5381, identify the product by make and model number, and follow the claim instructions that will be provided. The product and the purchase receipt must be provided to Us in order to process Your warranty claim. Any returned product that is replaced or refunded by Us becomes our property. You will be responsible for return shipping costs or costs related to Your return visit to a retail store.

Remedy Limits

Product replacement or a refund of the purchase price is Your sole remedy under this limited warranty or any other warranty related to the product. We shall not be liable for: service or labor charges or damage to Your property incurred in removing or replacing the product; any damages, including, without limitation, damages to tangible personal property or personal injury, related to Your improper use, installation, or maintenance of the product or product component; or any indirect, incidental or consequential damages of any kind for any reason.

Assumption of Risk

You acknowledge and agree that any use of the product for any purpose other than the specified use(s) stated in the product instructions is at Your own risk.

Governing Law

This limited warranty gives You specific legal rights, and You also may have other rights which vary from state to state. Some states do not allow limitations or exclusions on implied warranties or incidental or consequential damages, so the above limitations may not apply to You. This limited warranty is governed by the laws of the State of Minnesota, without regard to rules pertaining to conflicts of law. The state courts located in Dakota County, Minnesota shall have exclusive jurisdiction for any disputes relating to this warranty.



Distributed by:
Northern Tool & Equipment Company, Inc.
Burnsville, Minnesota 55306
www.northerntool.com

Made in China