

18" Trencher



WARNING

READ AND UNDERSTAND THIS OPERATOR'S MANUAL COMPLETELY BEFORE USING THIS ATTACHMENT. ASSEMBLE, TEST AND USE ONLY IN ACCORDANCE WITH THE OPERATOR'S MANUAL INSTRUCTIONS.





Table of Contents

- 1. Safety 3
 - 1.1 Safety Precautions 3
 - 1.2 Operating Safety 3
 - 1.3 Mechanical Hazards 4
 - 1.4 Fire and Explosion Hazards 4
 - 1.5 Chemical Hazards 4
 - 1.6 Noise Hazards 5
 - 1.7 Protective clothing 5
 - 1.8 Operator Safety using Internal Combustion Engines 5
 - 1.9 Handle Assembly 5
 - 1.10 Key Components 6
 - 1.11 Label Locations 6
 - 1.12 Safety and Operating Labels 7
 - 1.12 Safety and Operating Labels (cont.) 8

- 2. Technical Data 9
 - 2.1. Specifications 9
 - 2.2. Dimensions In 9

- 3. Operation 9
 - 3.1 Operating Principle 9
 - 3.2. Delivery Checks 9
 - 3.3 Before Starting 10
 - 3.4 Digging Chain Tension 10
 - 3.5 Wheel Ratchet Adjustment 11
 - 3.6 Starting Gasoline Engine 11
 - 3.7 To Stop 11
 - 3.8 Operation 12

- 4. Parts 14
- 5. Maintenance 16
 - 5.1 Periodic Maintenance Schedule 16
 - 5.2 Pivot Shaft 16
 - 5.3 V-Belt and Clutch 16
 - 5.4 Replacing the V-Belt 16
 - 5.5 Checking the Clutch 17
 - 5.6 Wheel Lock Adjustment 17
 - 5.7 Air Cleaner 17
 - 5.7 Spark Plug 18
 - 5.8 Transporting 18

1. Safety

1.1 Safety Precautions



Before using this equipment, study the operator's manual to become familiar with its operation. Do NOT allow un-trained or unauthorized persons, especially children, to operate this equipment. Use only factory authorized parts for service.

	<p>This is the safety alert symbol. It is used to alert you to potential personal injury hazards. Obey all safety messages that follow this symbol to avoid possible injury or death.</p>
	<p>DANGER (red) indicates an imminently hazardous situation which, if not avoided, will result in death or serious injury.</p>
	<p>WARNING (orange) indicates a potentially hazardous situation which, if not avoided, could result in death or serious injury.</p>
	<p>CAUTION (yellow) indicates a potentially hazardous situation which, if not avoided, may result in minor or moderate injury.</p>
	<p>CAUTION (yellow) used without the safety alert symbol indicates a potentially hazardous situation which, if not avoided, may result in property damage.</p>

fig01453

1.2 Operating Safety

- Slip/Trip/Fall is a major cause of serious injury or death. Beware of uneven or slippery work surfaces.
- Exercise care when working in the vicinity of unprotected holes or excavations.
- NEVER allow any person to operate this equipment without adequate instruction.
- Ensure all operators read, understand and follow the operating instructions.
- Serious injury could result from improper or careless use of this machine.
- Trenchers are heavy units and should be positioned by two people of appropriate strength. Use the lift handles provided on the machine, along with correct lifting techniques.



1.3**Mechanical Hazards**

- DO NOT operate the machine unless all protective guards are in place.
- Keep hands and feet clear of rotating and moving parts as they will cause injury if contacted.
- Ensure that the engine operation switch is in the OFF position and the spark plug ignition lead is disconnected before removing the guards or making adjustments.
- Ensure both the machine and the operator are stable by setting up on level terrain so the machine will not tip over, slide or fall while in operation or unattended.
- Do not leave the machine running while unattended.
- Ensure that the area to be dug does not contain any live electrical cables, gas, water, sprinkler, communication cables or any other utilities.
- Exercise care when operating unit. Exposure to vibration or repetitive work actions may be harmful to hands and arms.
- NEVER stand on the unit while it is operating. NEVER allow others to stand on the unit.
- Be careful not to come in contact with the muffler when the engine is hot. This will cause burns.
- Ensure that the repairs to the motor and machine are carried out by qualified personnel.



**Know what's below.
Call before you dig.**

**1.4****Fire and Explosion Hazards**

- Gasoline is extremely flammable and explosive under certain conditions.
- Ensure that gasoline is only stored in approved storage containers.
- DO NOT refuel the motor while it is running. Allow the motor to totally cool before refueling.
- DO NOT refuel the motor in the vicinity of sparks, flame or anyone smoking.
- DO NOT overfill the fuel tank and avoid spilling gasoline when refueling. Spilled gasoline or gasoline vapor may ignite. If spillage occurs, ensure that the area is cleaned and dry before starting the motor.
- Ensure that the fuel cap is securely fitted after refueling.

**1.5 Chemical Hazards**

- DO NOT operate or refuel a gasoline engine in a confined space or any area without adequate ventilation.
- Carbon monoxide and other components of exhaust gases from internal combustion engines can cause death in confined spaces.



1.6 Noise Hazards

- Excessive noise can lead to temporary or permanent loss of hearing.
- Wear an approved hearing protection device to limit noise exposure.



1.7 Protective clothing

- Always wear approved hearing and eye protection when working with the machine.
- Protective eyewear and a dust mask should be worn.
- Protective clothing and footwear are required.
- Do not wear any open-toed shoes or sandals.



1.8 Operator Safety using Internal Combustion Engines

- DO NOT smoke when refueling the engine or during any other fuel handling operation.
- DO NOT refuel a hot or running engine.
- DO NOT refuel the engine near an open flame or sparks.
- DO NOT spill fuel when refueling the engine.
- If fuel is spilled during refueling, wipe it off from the engine immediately and discard the rag in a safe place.
- DO NOT operate the unit if fuel or oil leaks exist. Repair immediately.
- Never operate this equipment in an explosive atmosphere or anywhere combustible gases have accumulated.
- Never operate any gas-powered equipment in a poorly ventilated or enclosed area.
- Avoid prolonged breathing of exhaust gases.
- Avoid contact with hot exhaust systems and engine parts.
- Allow engine to cool before performing any repairs, adjustments or service.
- Always transport and handle fuel only in approved safety containers.
- Always keep the area around the muffler free of debris such as leaves, paper cartons or anything combustible. A hot muffler could ignite debris and start a fire.

1.9 Handle Assembly

The trencher comes with the handle removed, but with the throttle cable and e-stop wire connected. Remove the trencher from the crate. Carefully rotate the handle up into position, ensuring that the throttle cable and stop wire do not become kinked, and fasten with six 5/16 x 1-1/4" hex head bolts and washers found in the hardware pack.

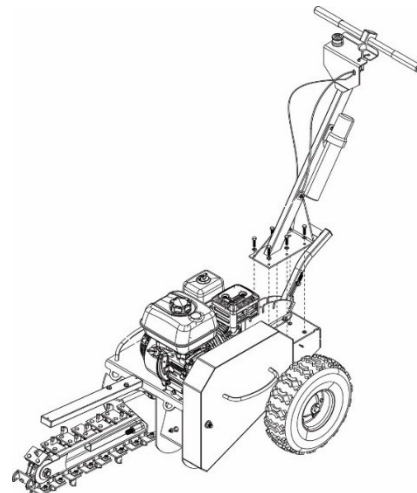

1.10 Key Components





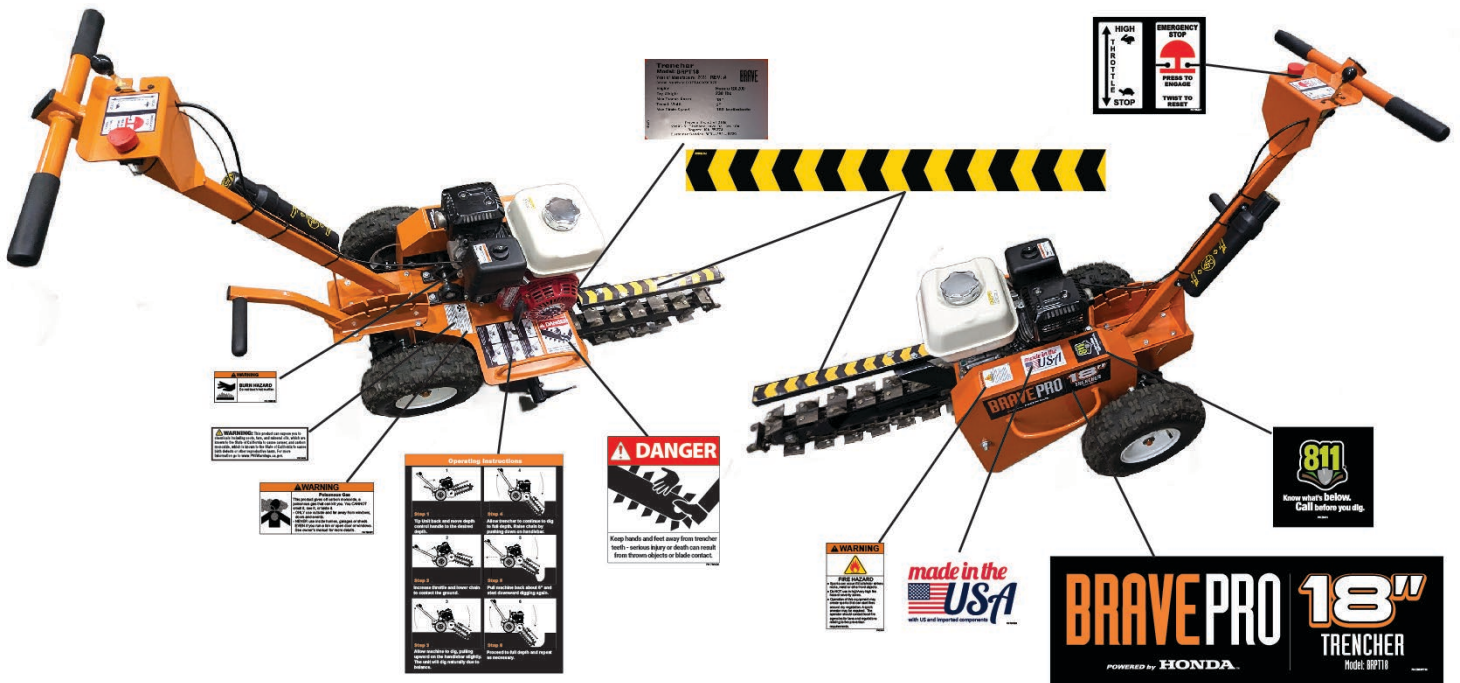





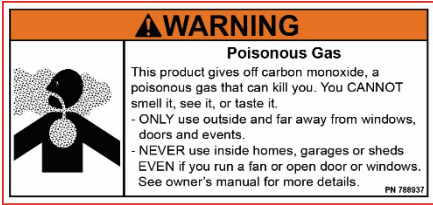

1.11 Label Locations









1.12 Safety and Operating Labels

Brave Pro Machines use international pictorial labels where needed. These labels are described below:

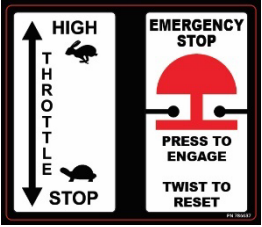
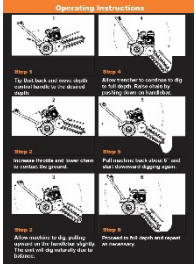
Label	Meaning
	<p>DANGER </p> <p>Engines emit carbon monoxide; operate only in well-ventilated areas. Read the Operation Manual for machine information. No sparks, flames, or burning objects near the machine. Shut off the engine before refueling. Use only clean, filtered unleaded gasoline.</p>
	<p>WARNING </p> <p>Flying Debris</p> <p>Always wear hearing and eye protection when operating this machine.</p>
	<p>DANGER </p> <p>Keep hands, Feet and clothing clear of rotating blades and trencher chain.</p>
	<p>CAUTION </p> <p>Fire Hazard. Do not use in high fire danger or dry conditions.</p>
	<p>WARNING </p> <p>Never dig near buried gas, electrical or any other utility line. Call and have all utilities marked before trenching.</p>

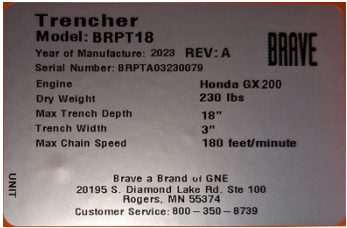
1.12 Safety and Operating Labels (cont.)

Label	Meaning
	<p>WARNING </p> <p>Hot mufflers and engines can cause burns.</p>
	<p>Throttle operation and Emergency STOP.</p>
	<p>Trencher Operating Instructions.</p>
	<p>Trencher Chain Location Marker</p>
	<p>A nameplate listing the model number and serial number is attached to each unit. Please record the information found on this plate so it will be available if the nameplate is lost or damaged. When requesting service information, the serial number should be specified of the unit.</p>
	<p>WARNING </p> <p>Exposure hazard.</p>

2. Technical Data

2.1. Specifications

Model	BRPT18
Engine	Honda GX200
Power HP	6.5
Operating Weight (lb.)	250 LBS
Digging Depth	18 In.
Chain Width	3 in.

2.2. Dimensions In.

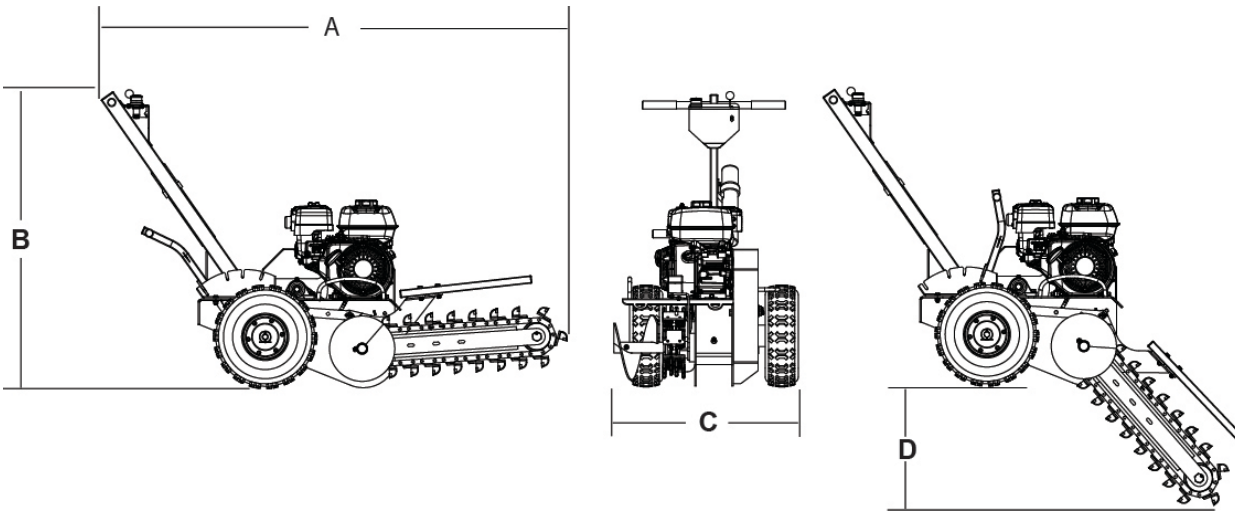

A	B	C	D
64.25 in.	41 in.	29.25 in.	18 in.

3. Operation

3.1 Operating Principle

The following instructions were compiled to provide you with information on how to obtain long and trouble-free use of this unit. Periodic maintenance of this unit is essential. Read the manual in its entirety and follow the instructions carefully. Failure to do so may injure yourself or a bystander.

3.2. Delivery Checks

Immediately on taking delivery of your new equipment and before putting it into service:

- Read the Operator's Manual completely – it could save a lot of time and unnecessary expense.
- Read the Engine Manual supplied.
- Check the general condition of the equipment – has it been damaged in shipment?
- Fill the engine with oil. Engine is shipped without oil and MUST be filled.
- Check the fuel level.
- Recommended lubrication and maintenance intervals are detailed in the Maintenance section.

3.3 Before Starting

The following Pre-start inspection must be performed before the start of each work session. If any fault is discovered, the Trencher must not be used until the fault is rectified.

1. Thoroughly inspect the Trencher for signs of damage. Check components are present and secure.
2. Check the engine oil level.
3. Check for fuel or oil leaks.

NOTICE. Check the oil level in the engine. Engine and Trencher warranties are VOID if the unit is run without oil.

3.4 Digging Chain Tension

To change the tension on the digging chain, loosen the jam nut using a 15/16" wrench and adjust using a 5/16" Allen wrench. The chain should be run fairly loose, with a droop of about 1 1/2". Re-tighten jam nut when finished setting tension. **DO NOT OVER TIGHTEN.**



3.5 Wheel Ratchet Adjustment

1. Place depth control lever in the full up position.
2. Locate adjustment set screw and Jam Nut.
3. Loosen Jam Nut.
4. Adjust the set screw inward until the locking ears just clear the wheel locks.
5. Retighten the jam nut.

NOTE: It may help to pull the locking ears back to better access the jam nut when loosening and tightening.

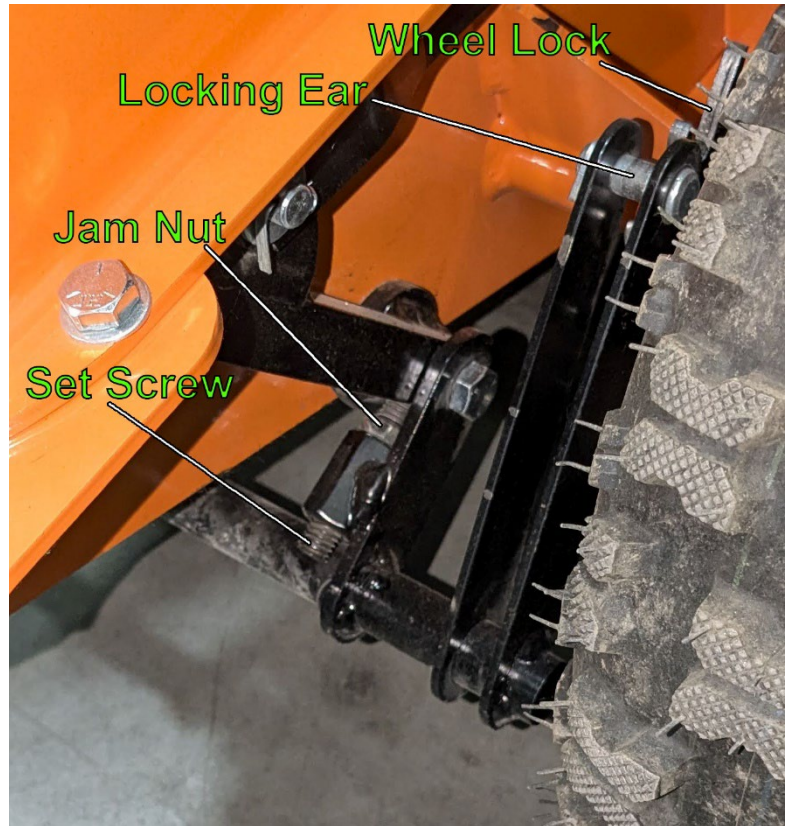

3.6 Starting Gasoline Engine

1. Open the fuel tap by moving the fuel ON/OFF lever fully to the right.
2. If starting the engine from cold, set the choke ON by moving the choke lever fully to the left. When restarting a warm engine, the choke is usually not required. However, if the engine has cooled to a degree, partial choke may be required.
3. Turn the engine ON/OFF switch clockwise to the "I" (ON) position.
4. Set the throttle to approximately $\frac{1}{4}$ from the idle position by moving the throttle lever.
5. Do not start the engine at full throttle, as the Trencher clutch will engage as soon as the engine starts.
6. Taking a firm hold of the control handle with one hand, grasp the recoil starter handle with the other. Pull the recoil starter until engine resistance is felt, then let the starter rope return.
7. Taking care not to pull the starter's rope fully out, pull the starter handle briskly.
8. Repeat until the engine starts.
9. Once the engine starts, gradually set the choke lever to the OFF position by moving it to the right.
10. If the engine fails to start after several attempts, follow the trouble-shooting guide in the engine manual.

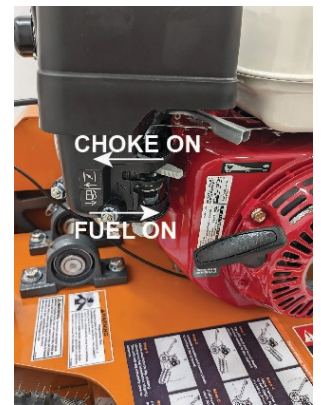

3.7 To Stop

1. Push the throttle to the idle (closed) position.
2. Turn the switch to the "O" (off) position.
3. Close the fuel valve.

3.8 Operation

Tip the unit back and move the depth control lever to the desired trenching depth. The first notch will yield approximately 8 inches of depth, second notch 12 inches depth, and third notch 18 inches depth. Moving the depth control forward engages the wheel ratchet locks, allowing the trencher to move backwards only. The wheel lock aids the downward digging of the chain.

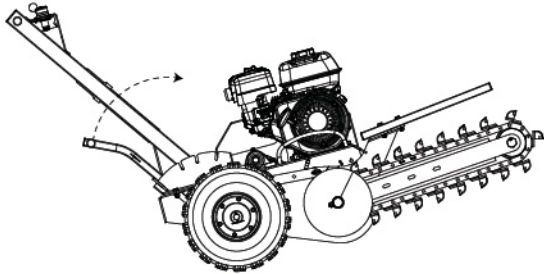
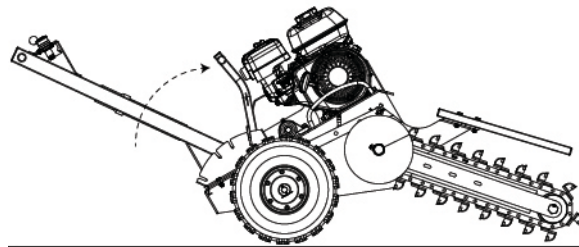
**Step 1****Step 2**

Increase the engine throttle to engage the clutch and lower the chain to contact the ground. Allow the machine to dig, pulling upward on the handlebar slightly. The unit will dig naturally due to balance of the machine and action of the chain and should not require much downforce from the operator.

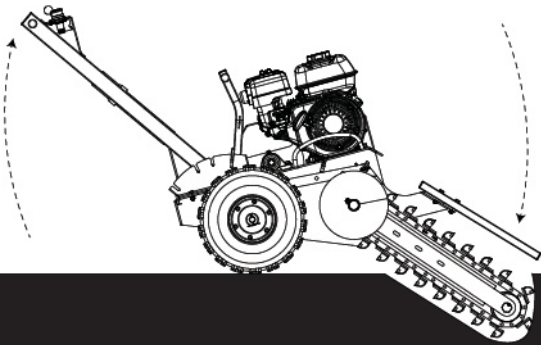
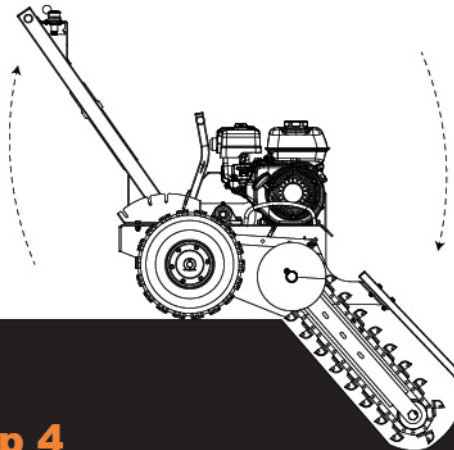
**Step 3****Step 4**

Allow the trencher to continue to dig until it reaches full depth selected. Raise the chain by pushing down on the handlebar. Pull the machine back approximately 6 inches and start the downward digging again.

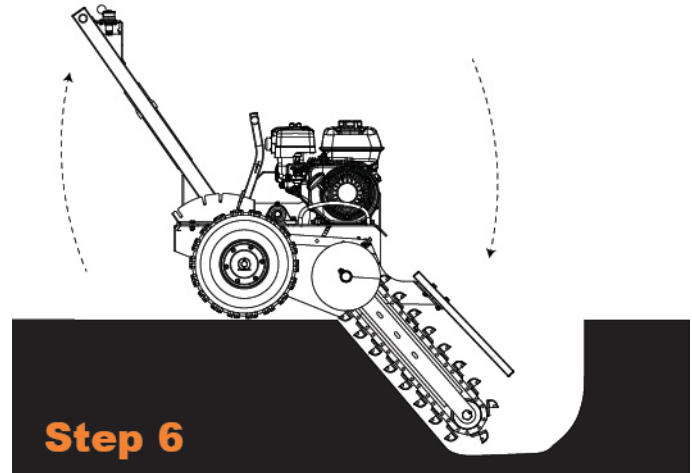
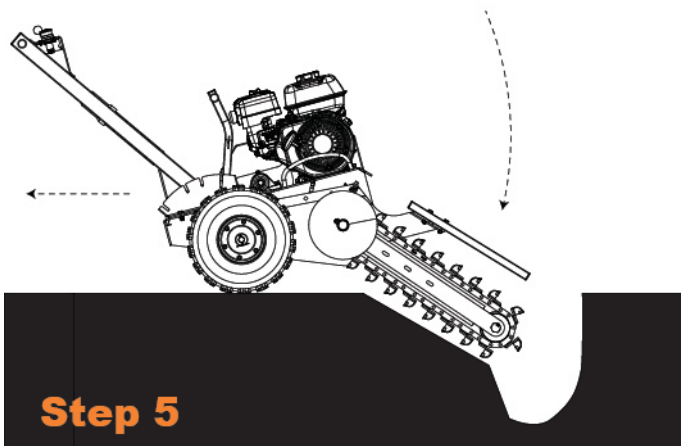

Proceed to full depth and repeat the process as necessary to create the trench desired.

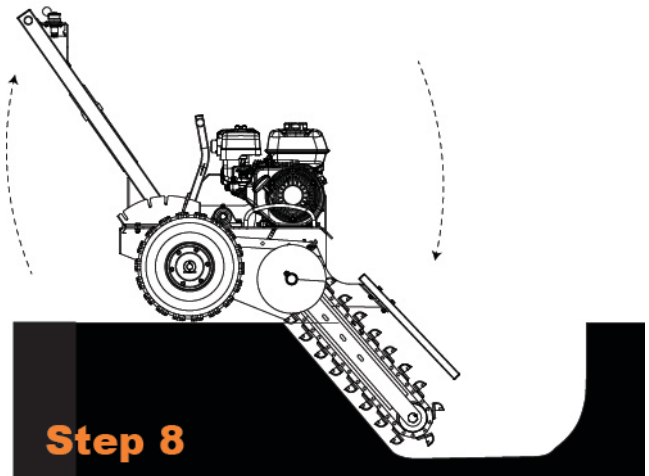
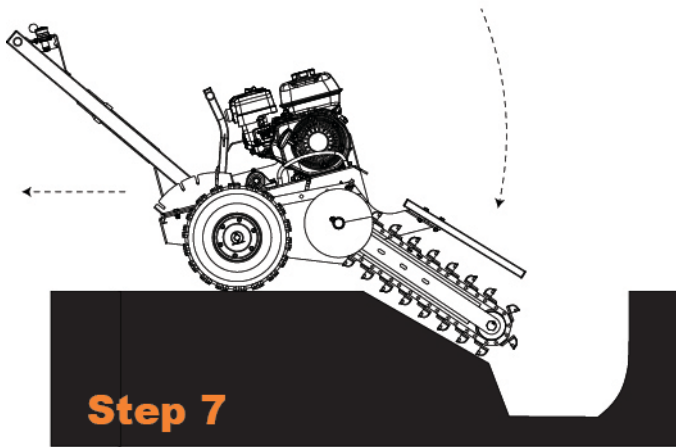

The trencher works best with downward digging and a sawing motion. The operator should not be dragging the trencher backward while digging.

4. Parts

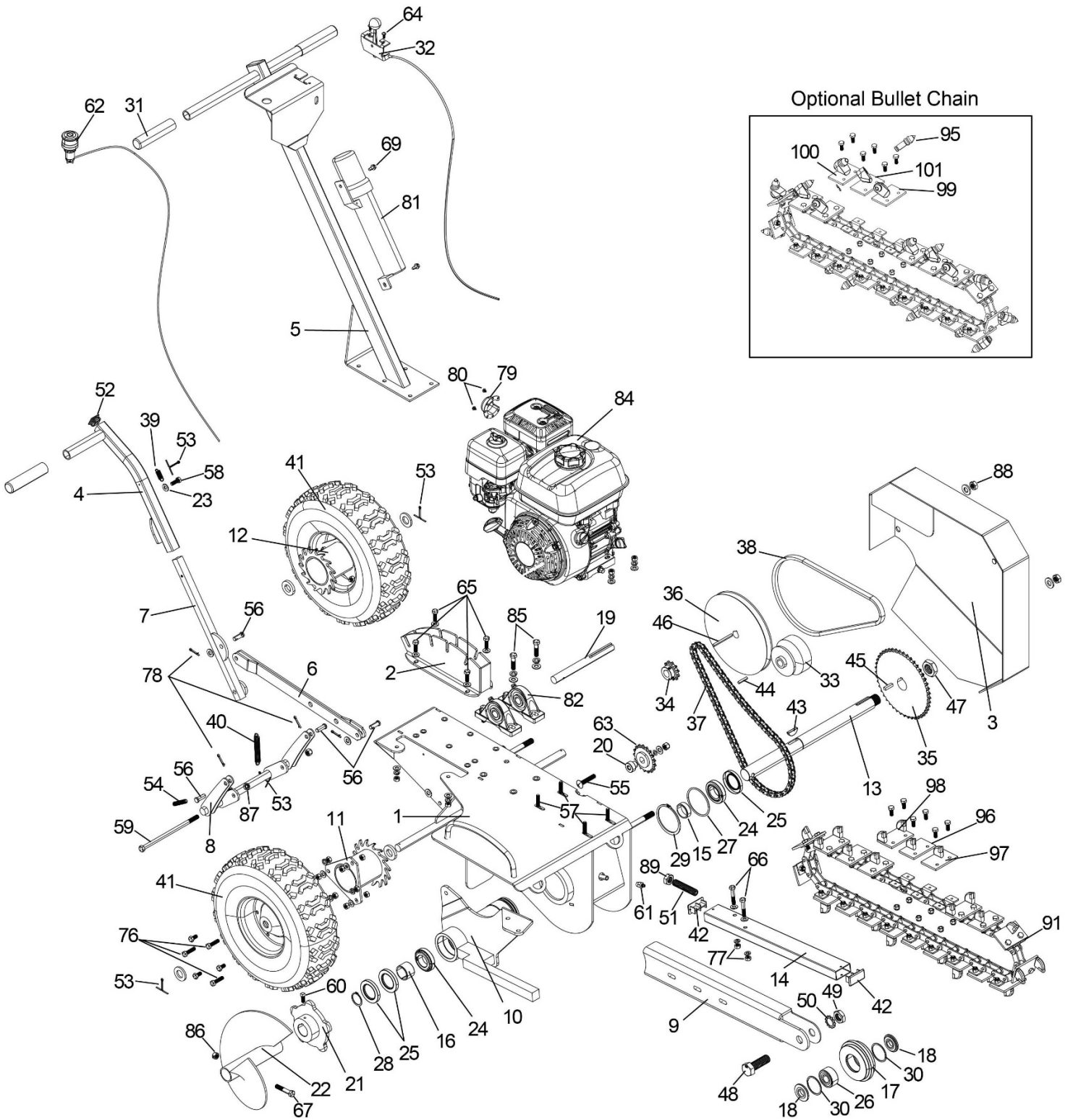



Operator's Manual

BRPT18

Item	Part Number	Description	QTY	Item	Part Number	Description	QTY
1	GPR111368	Trencher Frame	1	51	GPR111354	Set Screw 5/8-11 x 3"	1
2	GPR111369	Depth Adjustment Guide	1	52	GPR111355	Square Cap 1"	1
3	GPR111370	Belt Cover	1	53	GPR111356	Cotter pin 1/8 x 1-3/4"	4
4	GPR111371	Depth Adjustment Handle	1	54	GPR111357	Set Screw 3/8-16 x 2"	1
5	GPR111372	Handle Bar	1	55	GPR111358	Carriage Bolt 3/8-16 x 2"	1
6	GPR111373	Depth Linkage	1	56	GPR111359	Clevis Pin 3/8 x 3/4"	4
7	GPR111374	Adjustment Handle Linkage	1	57	GPR111360	Carriage Bolt 5/16-18 x 1-1/2"	4
8	GPR111375	Wheel Lock	1	58	GPR111598	Shoulder Bolt 5/16 x 1/2, 5/16-18	1
9	GPR111376	Trencher Chain Arm	1	59	GPR111362	Hex Head Bolt 3/8-16 x 7-1/2"	1
10	GPR111377	Trunnion Arm	1	60	GPR111363	Set Bolt, square Head 5/16-18 x 3/4"	1
11	GPR111378	Wheel Lock Right Hand	1	61	GPR111364	Grease Fitting	1
12	GPR111379	Wheel Lock Left Hand	1	62	GPR111365	E-Stop Switch and Harness	1
13	GPR111380	Trencher Drive Shaft	1	63	GPR111366	#40 Chain Idler sprocket	1
14	GPR111381	Trencher Guard Arm	1	64	GPR111367	Pan Head sheet metal screw #8	2
15	GPR111382	Short Spacer Bushing	1	65	80038	Hex Head Bolt 5/16-18 x 1"	4
16	GPR111383	Long Spacer Bushing	1	66	82494	Hex Head Bolt 5/16-18 x 1-3/4"	2
17	GPR111384	Trencher Chain Idler	1	67	82335	Hex Head Bolt 3/8-16 X 2"	1
18	GPR111385	Trencher Chain Idler Grit Washer	2	68	82508	Hex nut 5/16-18	20
19	GPR111386	Belt Pulley Shaft	1	69	80193	Hex Head screw 1/4-20 x 1/2"	2
20	GPR111387	Roller Chain Idler Stepped Bushing	1	70	82100	Lock Washer 5/16"	14
21	GPR111388	Trencher Drive Sprocket	1	71	82345	Lock Washer 3/8"	4
22	GPR111389	Dirt Discharge Auger Assembly	1	72	80205	Flat Washer 5/16" SAE	18
23	GPR111390	Depth Handle Washer	1	73	80206	Flat Washer 3/8" SAE	9
24	GPR111325	Bearing 1-1/4"	2	74	82038	Flat Washer 1/2" SAE	2
25	GPR111326	Grease Seal, Bearing	3	75	82042	Flat Washer 3/4" SAE	2
26	GPR111327	Bearing, 20mm	1	76	86115	Hex Head Bolt 5/16-18 x 1-1/4"	6
27	GPR111328	O-Ring #232	2	77	86383	Nylon Locknut 3/8-16	2
28	GPR111329	External Retaining Ring 1-1/4"	1	78	82139	Cotter pin 1/8 x 1"	5
29	GPR111330	External Retaining Ring 3"	1	79	MUF-18348	Exhaust Deflector	1
30	GPR111331	Spiral Retaining Ring 1-7/8"	2	80	87437	Hex Head screw #8 x 1/4"	2
31	GPR111332	Handle Grip	3	81	790471	Manual Holder	1
32	GPR111333	Throttle Cable	1	82	140101	Pillow Block Bearing, 3/4"	2
33	GPR111334	Clutch - 3/4" shaft	1	83	82008	10-32 KEPS Nut	2
34	GPR111335	#40 chain Sprocket 11 tooth	1	84	GX200	Honda Engine GX200	1
35	GPR111336	#40 chain Sprocket 45 tooth	1	85	GPR111320	Hex Head Bolt 3/8-16 x 1-1/2"	4
36	GPR111337	Belt Pulley - 3/4" bore	1	86	GPR111321	2-Way Locknut 3/8-16	1
37	GPR111338	#40 Drive chain	1	87	GPR111322	Jam Nut 3/8-16	1
38	GPR111339	V-Belt AX-35	1	88	GPR111323	Jam Nut 1/2-13	2
39	GPR111340	Spring - Depth Control Handle	1	89	GPR111324	Jam Nut 5/8-11	1
40	GPR111341	Spring - Wheel Ratchet Lock	1	90	GPR111392	18" Digging Chain - Bare W/Master	1
41	GPR111342	Tire 15 x 5.00-6	2	91	GPR111393	18" Shark Chain Complete W/Teeth	1
42	GPR111343	Tube Cap 1 x 2"	3	92	GPR111395	Digging Chain Master Link (outer)	1
43	GPR111344	Woodruff Key #21	1	93	GPR111396	Digging Chain Roller Link (inner)	
44	GPR111345	Square Key 3/16 x 1-1/8"	1	94	GPR111397	Clip - Bullet Tooth	21
45	GPR111346	Square Key 1/4 x 1"	1	95	GPR111398	Bit W/Clip - Optional Bullet Chain	21
46	GPR111347	Square Key 3/16 x 2-1/2"	1	96	GPR111399	Right Shark Tooth W/Hardware	7
47	GPR111350	Flexloc Hex Nut 1"-14	1	97	GPR111400	Left Shark Tooth W/Hardware	7
48	GPR111351	Hex Head BoltM20-2.5 x 60mm	1	98	GPR111401	Double Shark Tooth W/Hardware	7
49	GPR111352	Jam Nut M20-2.5	1	99	GPR111402	Right Holder - Optional Bullet Chain	7
50	GPR111353	Star Washer M20	1	100	GPR111403	Left Holder - Optional Bullet Chain	7
				101	GPR111404	Middle Holder -Optional Bullet Chain	7

5. Maintenance

5.1 Periodic Maintenance Schedule.

Refer to the engine manufacturer's Operation Manual for additional information on engine maintenance. A copy of the engine Operation Manual was supplied with the machine when it shipped.

	Daily	At first 20 hours	Every 50 hours	Every 100 hours	Every 200 hours
(Starting check)	●				
Loose or lost screws	●				
Damage of any part	●				
E-stop switch Function	●				
V-belt (clutch) check					●
Leakage of oil or fuel	●				
Engine oil check and replenishment	●				
Engine oil replacement		●		●	
Air cleaner			●		
Digging Chain Tension	●				
Pillow Block Bearings - Grease		●			

 These inspection intervals are for operation under normal conditions. Adjust your inspection intervals based on the number of hours the Trencher is in use and working conditions. Dusty environments may necessitate more frequent service.

5.2 Pivot Shaft

Add grease to the main drive shaft Pivot. Grease fitting daily.

5.3 V-Belt and Clutch

After 200 hours of operation, remove the belt cover to check the v-belt tension and drive chain tension. Loose or worn v-belts reduce the power transmission efficiency, causing weak digging and reduces the life of the belt itself.

 NEVER attempt to check the v-belt with the engine running. Severe injury can occur if your hand gets caught between the belt and the clutch. Always wear gloves.

5.4 Replacing the V-Belt

Remove the belt cover. Use care to keep fingers from being entangled in the belt pulley.

Loosen engine mount bolts and slide engine to reduce belt tension.

Work belt off the large pulley and replace with new belt. Re-set the belt tension by sliding the engine and tighten engine mount bolts.



5.5 Checking the Clutch

Check the clutch at the same time the V-belt is checked. With the belt removed, check the outer drum of the clutch for seizure and v-groove wear or damage visually. Clean the v-groove as necessary. Wear of the lining or shoe should be evident while the unit is in operation. If a shoe is worn, power transmission becomes deficient and slipping will result.



Whenever the digging becomes weak during normal operation, regardless of operational hours, check the v-belt and clutch immediately.

5.6 Wheel Lock Adjustment

1. Place depth control lever in the full up position.
2. Locate adjustment set screw and Jam Nut.
3. Adjust the set screw inward until the locking ears just clear the wheel locks.
4. Retighten the jam nut.

NOTE: It may help to pull the locking ears back to better access the jam nut when loosening and tightening.

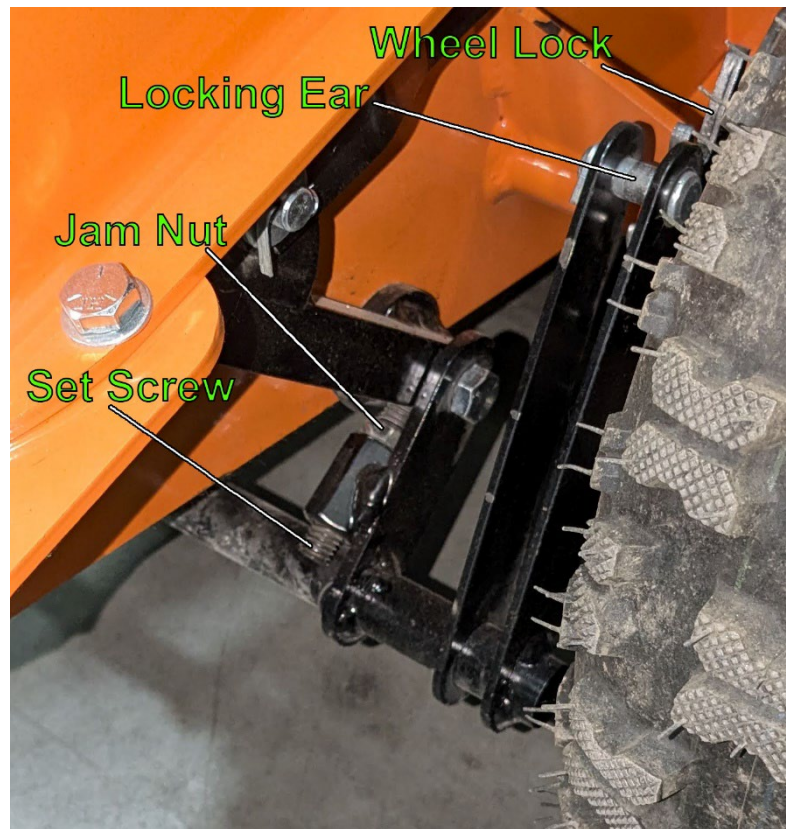

5.7 Air Cleaner

1. The air filter element should be cleaned often because a clogged air cleaner can cause poor engine starting, lack of power and shorten the life of the engine substantially.
2. To clean or replace the air filter, loosen the wingnut on the air filter housing (Fig. 1), remove the cover and take out the air filter cartridge. If you are only cleaning the air filter, blow compressed air through the filter cartridge from the inside, moving to cover the entire filter area.

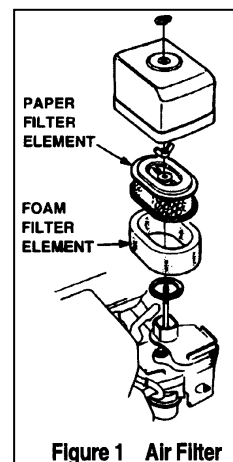

5.7 Spark Plug

Check and clean or replace spark plugs regularly.

A fouled, dirty spark plug may cause hard starting and poor engine performance. Set spark plug gap to recommended clearance. Refer to engine manual.



The muffler and engine cylinder become very hot during operation and remain hot for some time after stopping the engine. You could suffer burns. Allow engine to cool before removing spark plug.

NOTICE: a loose spark plug can become very hot and may cause engine damage.

5.8 Transporting

1. Always shut off the engine when transporting machine.
2. Shut off the fuel before transporting machine.
3. Secure the Trencher with suitable tie downs.



20195 South Diamond Lake Road, Suite 100 • Rogers, MN 55374
Toll-Free: 800-350-8739 • Website: GNEDI.com • Email: Techservices@GNEDI.com

Dear Valued Customer:

The Brave product you just purchased is built with the finest material and craftsmanship. Use this product properly and enjoy the benefits from its high performance. By purchasing a Brave product, you show a desire for quality and durability. Like all mechanical equipment this unit requires a due amount of care. Treat this unit like the high-quality piece of machinery it is. Neglect and improper handling may impair its performance.

Thoroughly read the instructions and understand the operation before using your product. Always contact Brave Product Support at 1-800-350-8739 prior to having any service or warranty work performed, as some services performed by parties other than Brave approved service centers may void this warranty. This limited warranty is in lieu of any other warranty expressed or implied, written or oral and Brave assumes no other responsibility or liability outside that expressed within this limited warranty.

**Limited Warranty for Brave Trenchers:
Model BRPT18**

	Consumer Warranty Period	Commercial Warranty Period
Weldments	2 years from date of purchase by user	2 years from date of purchase by user
Wear Parts	In addition to the normal warranty, Brave shall warrant some normal wear items from defects in material or workmanship for a period of 30 days from the date of purchase by user. Normal wear items covered under this warranty are limited to: High impact wear related components such as standard retention hardware for wear items, chains, bits, sprockets, bearings, belts and bushings, centrifugal clutch components such as shoes, springs, drum and rotor assembly, rotors, rubber drapes or flaps, drive and driven pulleys. Routine maintenance items such as lubricants, clutch adjustments, tune ups are not covered under warranty.	
Engines	The engine warranty is covered under the terms and conditions as outlined by the engine manufacturer’s warranty contained herein and is the sole responsibility of the engine manufacturer. Normal engine maintenance such as spark plugs, oil changes, air filters, adjustments, fuel system cleaning and obstruction due to build up is not covered by this Brave limited warranty.	

“Consumer use” means personal residential household use by a consumer. “Commercial use” means all other uses, including, but not limited to, use for commercial, income producing or rental purposes or when purchased by a business.

This limited warranty applies to the original purchaser of the equipment (verification of purchase, in the form of a receipt, is the responsibility of the buyer), is non-transferable, and covers parts and labor. Parts will be replaced or repaired at no charge, except when the equipment has failed due to lack of proper maintenance. If a part is no longer available, the part may be replaced with a similar part of equal function. Any misuse, abuse, alteration or improper installation or operations will void the warranty. Determining whether a part is to be replaced or repaired is the sole decision of Brave. Brave will not provide replacement of complete products due to defective parts. Any costs incurred due to replacement or repair of items outside of a Brave approved facility is the responsibility of the buyer and not covered under warranty. Transportation costs to and from the service center and/or service calls are the responsibility of the customer.

This limited warranty specifically excludes the following: failure of parts due to damage caused by accident, fire, flood, windstorm, acts of God, applications not approved by Brave in writing, corrosion caused by chemicals, use of replacement parts which do not conform to manufacturer’s specifications, damage related to rodent and/or insect infestation and damage caused by vandalism. Additional exclusions: loss of running time, inconvenience, loss of income, or loss of use, including any implied warranty of merchantability of fitness for a specific use. Also, outdoor power equipment needs periodic parts and service to perform well, and this limited warranty does not cover instances when normal use has exhausted the life of a component or the engine.

This limited warranty does not cover any personal injury or damage to surrounding property caused by failure of any part, misuse, or inability to use the product. Alteration of the product, including safety features, shall void this limited warranty.

Repair or replacement of parts does not extend the warranty period. This limited warranty gives you specific legal rights. You may also have other rights that vary by state. Please have model number, item number and serial number on hand prior to making a warranty claim or inquiry.

For products purchased on or after January 1, 2024



BRAVE

20195 S. Diamond Lake Rd, Ste 100
Rogers, MN 55374
1-800-350-8739
GNEDI.com

8/2023