

iron ton™

500-LB. CAPACITY STEEL CARGO CARRIER

Owner's Manual

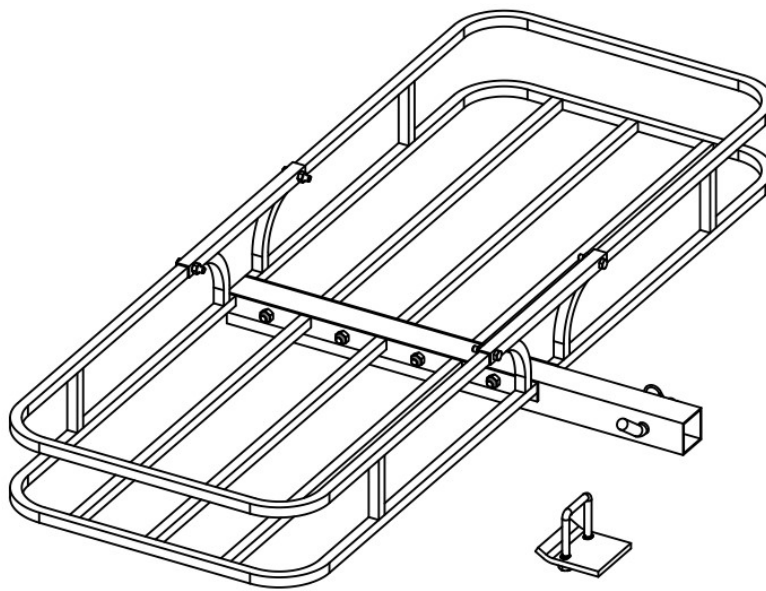

⚠ WARNING: Read carefully and understand all ASSEMBLY AND OPERATION INSTRUCTIONS before operating. Failure to follow the safety rules and other basic safety precautions may result in serious personal injury.

Item #6110964

READ & SAVE THESE INSTRUCTIONS

Thank you very much for choosing an Iron-ton product!

For future reference, please complete the owner's record below:

Serial Number/Lot Date Code: _____

Purchase Date: _____

Save the receipt, warranty, and this manual. It is important that you read the entire manual to become familiar with this product before you begin using it.

This product is designed for certain applications only. Northern Tool and Equipment is not responsible for issues arising from modification or improper use of this product such as an application for which it was not designed. We strongly recommend that this product not be modified and/or used for any application other than that for which it was designed.

For technical questions, please call **1-800-222-5381**.

Table of Contents

Intended Use	4
Technical Specifications	4
Important Safety Information.....	4
Specific Operation Warnings	6
Main Parts of Product	6
Assembly Instructions	6
Operating Instructions	8
Maintenance	8
Parts Diagram	9
Parts List	9
Replacement Parts	10
Limited Warranty	11

Intended Use

The Ironton 500-Lb. Capacity Steel Cargo Carrier fits in a 2-inch receiver and can carry up to a 500-lb. load. The cargo carrier is easy to assemble with heavy-duty, tubular steel construction and rails on all four sides providing maximum stability during travel.

Technical Specifications

Property	Specification
Rated Capacity	500 Lb.
Material	Steel
Dimensions (Inches)	53.5"(L) x 19.5"(W) x 5"(H)

Important Safety Information

⚠WARNING

- Read and understand all instructions. Failure to follow all instructions may result in serious injury or property damage.
- The warnings, cautions, and instructions in this manual cannot cover all possible conditions or situations that could occur. Exercise common sense and caution when using this tool. Always be aware of the environment and ensure that the tool is used in a safe and responsible manner.
- Do not allow persons to operate or assemble the product until they have read this manual and have developed a thorough understanding of how it works.
- Do not modify this product in any way. Unauthorized modification may impair the function and/or safety and could affect the life of the product. There are specific applications for which the product was designed.
- Use the right tool for the job. DO NOT attempt to force small equipment to do the work of larger industrial equipment. There are certain applications for which this equipment was designed. This product will be safer and do a better job at the capacity for which it was intended. DO NOT use this equipment for a purpose for which it was not intended.
- Industrial or commercial applications must follow OSHA requirements.

⚠WARNING

- This product may contain chemicals known to the state of California to cause cancer, birth defects, or other reproductive harm.
- Some dust created by power sanding, sawing, grinding, drilling, and other construction activities contains chemicals known to the state of California to cause cancer, birth defects, or other reproductive harm. Some examples of these chemicals are:
 - lead from lead-based paints,
 - crystalline silica from bricks and cement and other masonry products, and
 - arsenic and chromium from chemically treated lumber.

- Your risk from these exposures varies, depending on how often you do this type of work. To reduce your exposure to these chemicals: work in a well-ventilated area, and work with approved safety equipment, such as dust masks that are specially designed to filter out microscopic particles.
- Handling power cords on corded products may expose you to lead, a chemical known to the state of California to cause cancer and birth defects or other reproductive harm. Wash your hands after handling.

⚠WARNING

WORK AREA SAFETY

- Inspect the work area before each use. Keep work area clean, dry, free of clutter, and well-lit. Cluttered, wet, or dark work areas can result in injury. Using the cargo carrier in confined work areas may put you dangerously close to cutting tools and rotating parts.
- Keep children and bystanders away from the work area while operating the cargo carrier. Do not allow children to handle the cargo carrier.

⚠WARNING

PERSONAL SAFETY

- Stay alert, watch what you are doing, and use common sense when operating the cargo carrier. Do not use the cargo carrier while you are tired or under the influence of drugs, alcohol, or medication. A moment of inattention while operating the cargo carrier may result in serious personal injury.
- Dress properly. Do not wear loose clothing, dangling objects, or jewelry. Keep your hair, clothing and gloves away from moving parts. Loose clothes, jewelry, or long hair can be caught in moving parts. Air vents on the tool often cover moving parts and should be avoided.
- Wear the proper personal protective equipment when necessary. Use ANSI Z87.1 compliant safety goggles (not safety glasses) with side shields, or when needed, a face shield. Use a dust mask in dusty work conditions. Also use non-skid safety shoes, hardhat, gloves, dust collection systems, and hearing protection when appropriate. This applies to all persons in the work area.
- Do not overreach. Keep proper footing and balance at all times.

⚠CAUTION

CARGO CARRIER USE AND CARE

- Do not modify the cargo carrier in any way. Unauthorized modification may impair the function and/or safety and could affect the life of the equipment. There are specific applications for which the cargo carrier was designed.

- Always check of damaged or worn-out parts before using the cargo carrier. Broken parts will affect the cargo carrier operation. Replace or repair damaged or worn parts immediately.
- Stores idle the cargo carrier. When the cargo carrier is not in use, store it in a secure place out of the reach of children. Inspect it for good working condition prior to storage and before re-use.

Specific Operation Warnings

⚠WARNING

- To prevent serious injury or property damage, read and understand owner's manual before operating.
- Follow all federal DOT and any applicable state laws and regulations for installation and use.
- Ensure vehicle taillights are not obstructed by the carrier or the load.
- Turn vehicle's ignition OFF, set parking brake, and chock wheels before installing.
- Prior to transporting make the load is properly secured to the carrier.
- Distribute weight evenly on cargo carrier and load heaviest items toward the center.
- Be aware of dynamic loading! Sudden load movement may briefly create excess load causing product failure.
- Be aware of openings and use larger containers that will not fall through gaps in the carrier's framework.
- Do not carry loads that are wider or deeper than the carrier. Always keep loads inside the rim of the carrier.
- Do not use to transport people or animals.
- When transporting a scooter, use wheel chocks to prevent rolling.
- Fire hazard. Do not allow exhaust fumes to blow directly on cargo.

Main Parts of Cargo Carrier

Reference	Subassembly
1	Steel Cargo Carrier

Assembly Instructions

⚠WARNING

- Flammable cargo can ignite from exposure to heat. Be aware of the possible fire risk and property damage resulting from the vehicle's exhaust system pointing at or running near the cargo in the carrier. DO not use if this condition exists.

Assembly steps

Step 1: Unpack all contents and compare to the parts list.

Step 2:

- Install U - bolts (1) through the black power coated plate (2). Install the spring washers M10 and the flat washers M10 (3) and the nuts M10 (4) onto the U - bolts (1). Tighten.
- Install four bolts (13) through the left frame (5), tube assembly (7), and right frame (12).
- Install the spring washers M10 and the flat washers M10 (3) and the nuts M10 (4) onto the bolts (13).
- Do not tighten the bolts until the cross brace (10) installation is complete.

Step 3: Place the cross brace (10) onto the frames and install the two bolts (8) cross brace and frames. Install the flat washers M8 (14) and nuts M8 (11) onto the bolts (8). Tighten.

Step 4: Tighten bolts from Step 2 now that cross brace (10) has been installed.

Step 5: Mount the assembled carrier into the receiver of the vehicle and secure with the 5/8" pin (6) and R pin (9).

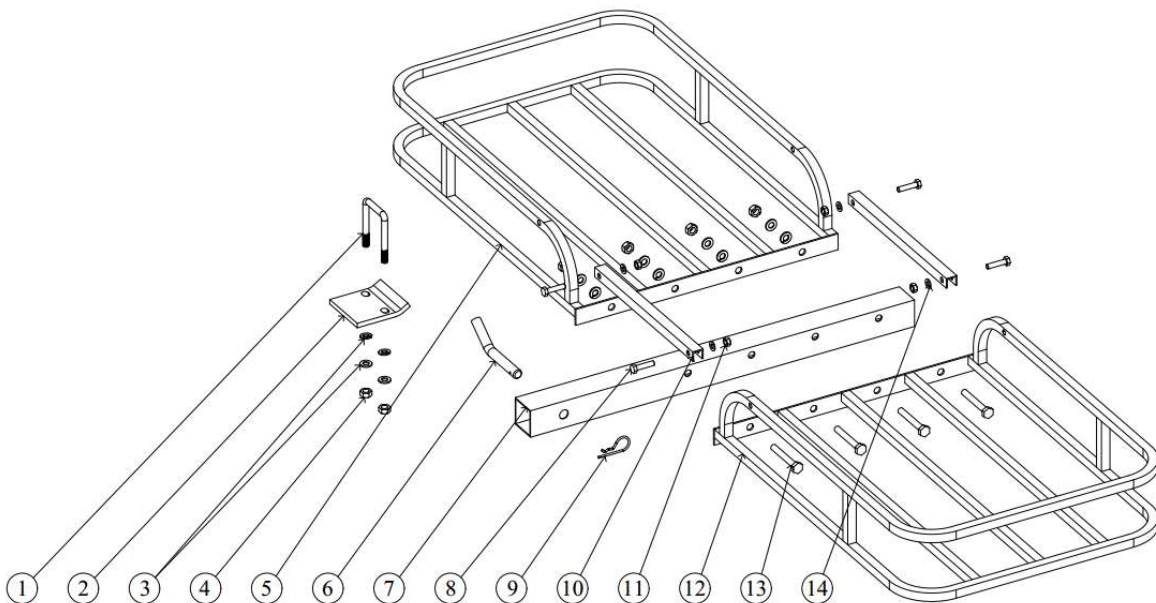

Operating Instructions

⚠WARNING

- Follow all federal DOT and any applicable state laws and regulations for installation and use.
- Ensure vehicle taillights are not obstructed by the carrier or the load.
- Prior to transporting make the load is properly secured to the carrier.
- Distribute weight evenly on cargo carrier and load heaviest items toward the center.
- Be aware of dynamic loading! Sudden load movement may briefly create excess load causing product failure.
- Be aware of openings and use larger containers that will not fall through gaps in the carrier's framework.
- Do not carry loads that are wider or deeper than the carrier. Always keep loads inside the rim of the carrier.
- Do not use to transport people or animals.
- When transporting a scooter, use wheel chocks to prevent rolling.
- Fire hazard. Do not allow exhaust fumes to blow directly on cargo.

With assistance, place items to be loaded onto the Carrier. Make sure the load is equally balanced on the Carrier. Secure the load in place using appropriate tie-downs, ropes, flags, etc. (not included)

Maintenance

- Maintain the cargo carrier with care. Inspect periodically, and if damaged, have it repaired by an authorized technician.
- For your safety, maintenance should be performed regularly by a qualified technician.

Parts Diagram

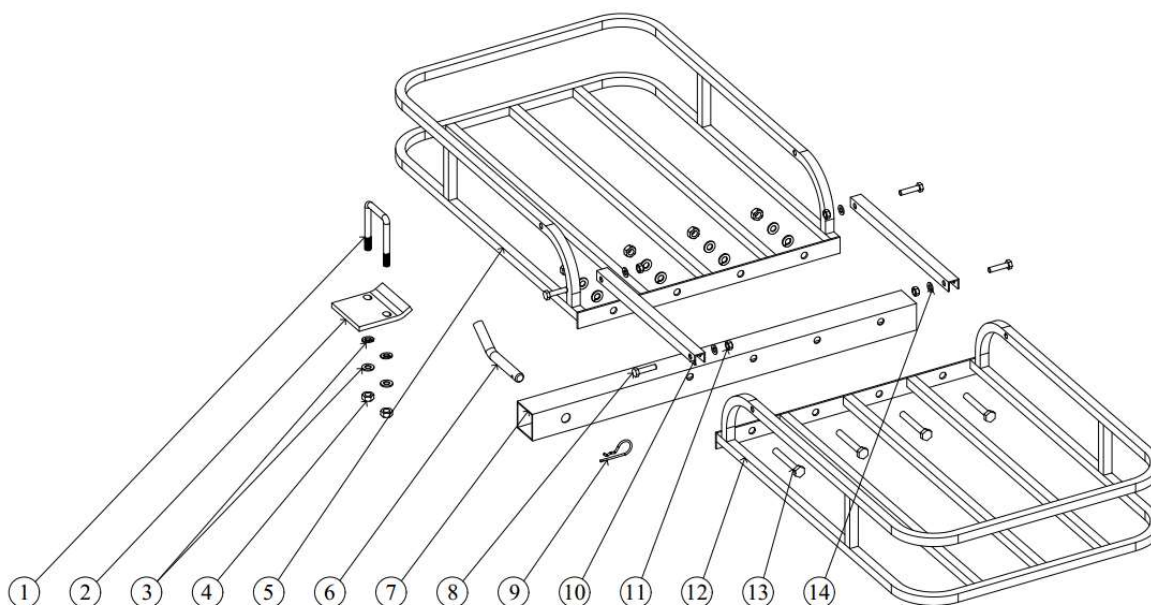

Parts List

No.	Part Number	Part Description	Quantity
1	6110964-001	U - Bolt	1-Pc
2	6110964-002	Black Power Coated Plate	1-Pc
3	6110964-003	Set of Flat and Spring Lock Washers M10	6-Set
4	6110964-004	Nut - M10	6-Pc
5	6110964-005	Frame (Left)	1-Pc
6	6110964-006	5/8" Hitch Pin	1-Pc
7	6110964-007	2" Post	1-Pc
8	6110964-008	Bolt – M8x35	4-Pc
9	6110964-009	R Pin	1-Pc
10	6110964-010	Cross Brace	2-Pc
11	6110964-011	Nut – M8	4-Pc
12	6110964-012	Frame (Right)	1-Pc
13	6110964-013	Bolt – M10x75	4-Pc
14	6110964-014	Flat Washers M8	4-Pc

Replacement Parts

- For replacement parts and technical questions, please call Customer Service at **1-800-222-5381**.
- Not all product components are available for replacement. The illustrations provided are a convenient reference to the location and position of parts in the assembly sequence.
- When ordering parts, the following information will be required: item description, item model number, item serial number/item lot date code, and the replacement part reference number.
- The distributor reserves the rights to make design changes and improvements to product lines and manuals without notice.

Limited Warranty

Northern Tool and Equipment Company, Inc. ("We" or "Us") warrants to the original purchaser only ("You" or "Your") that the Ironton product purchased will be free from material defects in both materials and workmanship, normal wear and tear excepted, for a period of **one year** from date of purchase. The foregoing warranty is valid only if the installation and use of the product is strictly in accordance with product instructions. There are no other warranties, express or implied, including the warranty of merchantability or fitness for a particular purpose. If the product does not comply with this limited warranty, Your sole and exclusive remedy is that We will, at our sole option and within a commercially reasonable time, either replace the product or product component without charge to You or refund the purchase price (less shipping). This limited warranty is not transferable.

Limitations on the Warranty

This limited warranty does not cover: (a) normal wear and tear; (b) damage through abuse, neglect, misuse, or as a result of any accident or in any other manner; (c) damage from misapplication, overloading, or improper installation; (d) improper maintenance and repair; and (e) product alteration in any manner by anyone other than Us, with the sole exception of alterations made pursuant to product instructions and in a workmanlike manner.

Obligations of Purchaser

You must retain Your product purchase receipt to verify date of purchase and that You are the original purchaser. To make a warranty claim, contact Us at 1-800-222-5381, identify the product by make and model number, and follow the claim instructions that will be provided. The product and the purchase receipt must be provided to Us in order to process Your warranty claim. Any returned product that is replaced or refunded by Us becomes our property. You will be responsible for return shipping costs or costs related to Your return visit to a retail store.

Remedy Limits

Product replacement or a refund of the purchase price is Your sole remedy under this limited warranty, or any other warranty related to the product. We shall not be liable for: service or labor charges or damage to Your property incurred in removing or replacing the product; any damages, including, without limitation, damages to tangible personal property or personal injury, related to Your improper use, installation, or maintenance of the product or product component; or any indirect, incidental or consequential damages of any kind for any reason.

Assumption of Risk

You acknowledge and agree that any use of the product for any purpose other than the specified use(s) stated in the product instructions is at Your own risk.

Governing Law

This limited warranty gives You specific legal rights, and You also may have other rights which vary from state to state. Some states do not allow limitations or exclusions on implied warranties or incidental or consequential damages, so the above limitations may not apply to You. This limited warranty is governed by the laws of the State of Minnesota, without regard to rules pertaining to conflicts of law. The state courts located in Dakota County; Minnesota shall have exclusive jurisdiction for any disputes relating to this warranty.

iron[®]ton™

Distributed by:

Northern Tool & Equipment Company, Inc.

Burnsville, Minnesota 55306

www.northerntool.com

Made in Vietnam

Page 12 of 12