

GREENCHOICE ERV

Single Room Energy Recovery Ventilator



FEATURES

- High thermal efficiency. Built-in high-tech ceramic energy regenerator with maximum heat recovery efficiency of up to 90%.
- Includes F7 (MERV11) filter and pre-filter to keep air clean.
- Energy efficient, reversible, 3 speed EC motor.
- Units can work individually or in paired master-slave setups.
- One unit can ventilate a room up to 500 sqft.
- CO2 and temperature sensors to monitor environment.
- Automatic backdraft shutter.
- Core and filters are protected with an antibacterial treatment.
- IPX4 water resistance.
- Quiet operation - less than 32.7dBA.
- Simple installation through an external wall with a single hole.
- Includes remote which can be used to control multiple devices.
- Can be controlled over WIFI with a smart phone.

MODES

The Greenchoice ERV can be set to supply, exhaust or energy recovery modes. When 2 units are set to run in a pair, one unit will exhaust air while the other is supplying air. Paired units in regeneration mode will alternate which unit is in exhaust and which is in supply every 75 seconds. There are also settings for 2 automatic functions to help reduce energy costs and improve indoor air quality:

Free cooling function: Set a desired indoor temperature and if the outdoor temperature drops below the set temperature, the unit will run in supply mode to help cool the room.

Air quality function: Set a threshold for the indoor concentration of CO2. when the unit detects CO2 levels above this threshold it will enter supply mode to introduce fresh air and lower CO2 levels.

SPECIFICATIONS

MODEL	GC30ERV-W			REGENERATION EFFICIENCY	up to 90%
VOLTAGE	100V-240V / 50-60Hz			SEC	Class A
POWER (W)	9.7	10.7	11.5	INGRESS PROTECTION RATING	IPX4
CURRENT (A)	0.14	0.15	0.016	NET WEIGHT (kg)	4.2
CFM	11.8	23.5	29.4		
NOISE LEVEL (dBA) @5ft	20	29	32.7		
MAX RPM	2200				

DIMENSIONS

DIMENSIONS (mm)	
A	77.2
B	280 - 470
C	142.5
D	239.6
E	258
ØD1	158
ØD2	156.5
ØD3	226.4

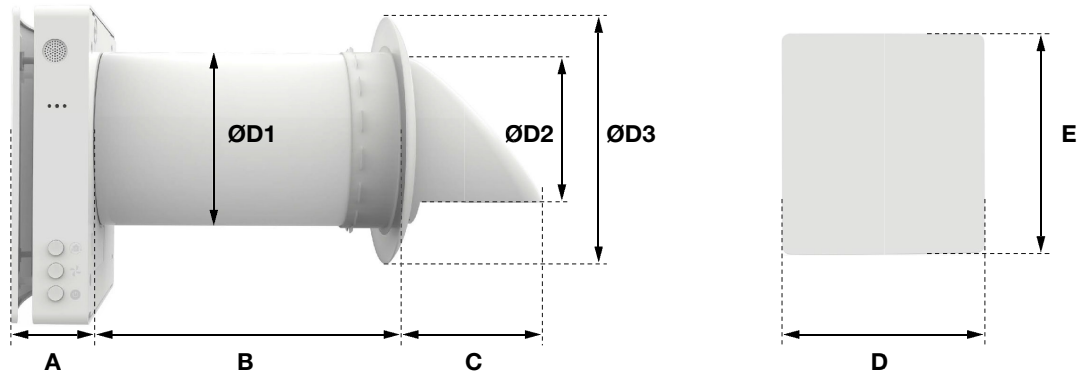

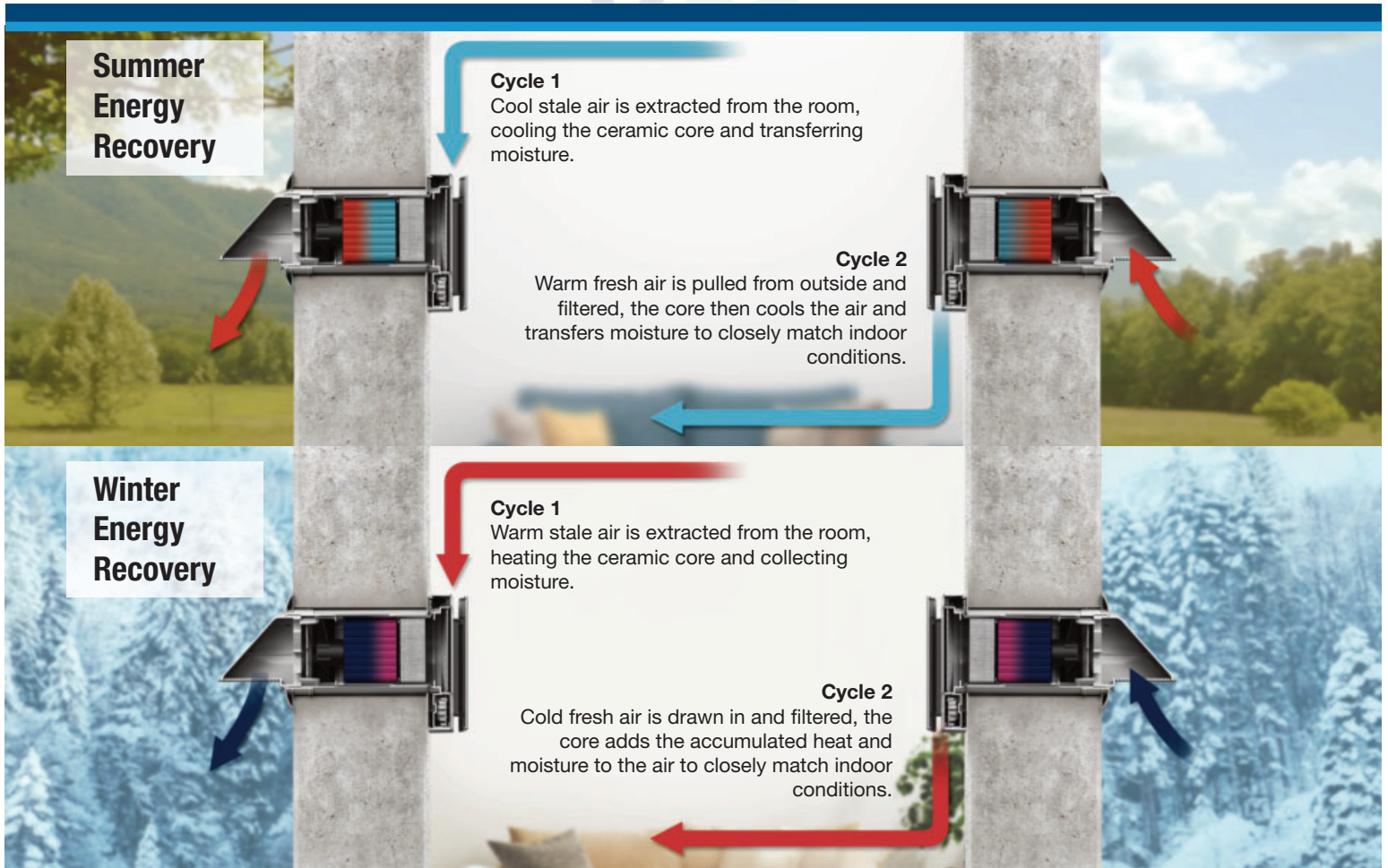

APP CONTROL

Control all units from a compatible android or apple device with the “Smart Vent” or “Smart Life” app. Use the QR codes below or find them in the Google play and Apple stores.

The Smart Life app works with Alexa and Google Assistant voice controls.

App Features

- On/off switch
- Fan speed selection
- Mode selection
- Pairing status
- Outdoor temperature display
- Filter alarm
- Free cooling settings
- CO2 concentration display & control
- 12 hrs timer setting
- Unit indicator lights ON/OFF
- Set a weekly schedule
- Fan boost function
- Multi unit grouping
- Smart control based on local weather
- Optional humidity control
- Optional Negative ion function



Smart Vent app



Smart Life app