

POWERHORSE™

Owner's Manual

M6105348A.1

ITEM NUMBER: 6105348

SERIAL NUMBER: _____

Instructions for Assembling, Testing, Operating, Servicing, and Storing

Water Pump: Outdoor agricultural product used for general purpose water pumping, field irrigation, and trash applications.

WARNING

READ and UNDERSTAND this manual completely before using the water pump! Failure to properly set up, operate, and maintain this water pump could result in *serious injury or death* from *carbon monoxide poisoning, electric shock, fire/explosion, or burns*. In particular, be aware of the following hazards:

CO Poisoning

Water pumps give off carbon monoxide, a poisonous gas that can kill you. You CANNOT smell it, see it, or taste it.

- ONLY run water pump OUTDOORS and at least 20 feet from the home, away from windows, vents and air intakes, to allow proper ventilation. If you start to feel sick, dizzy, or weak while using the water pump, shut off the engine and get to fresh air RIGHT AWAY. NEVER run water pump inside any enclosed or semi-enclosed spaces, including homes, basements, garages, sheds, boxes, RVs, boats or pick-up truck beds. These spaces can trap poisonous gases, EVEN if you run a fan or open windows.
- Install carbon monoxide alarms inside nearby structures/buildings (battery-operated, or plug-in with battery backup).

Fire / Explosion

- DO NOT overload water pump (per rated capacity), and OPERATE ONLY in an area with adequate cooling ventilation so engine does not overheat. Exhaust can be extremely hot. Keep muffler at least 7 feet from all combustible objects.
- All fuels are flammable. Never fuel a running or hot engine. Never pump fuel directly into water pump at gas station – use approved container to transfer fuel. Ensure there are no fuel leaks, and keep sources of sparks and flames away.
- ALWAYS keep a fire extinguisher rated “ABC” nearby.
- NEVER pump flammable liquids.

STOP!

INSPECT COMPONENTS: Closely inspect to make sure no components are missing or damaged. See the “Unpacking & Delivery Inspection” section for instructions on whom to contact to report missing or damaged parts.

ADD ENGINE OIL: Engine is shipped without oil. See engine section of this manual for instructions on capacity and viscosity recommendations.

Any Questions, Comments, Problems, or Parts Orders

Call Powerhorse Product Support 1-866-443-2576

Hazard Signal Word Definitions





	<p>This is the safety alert symbol. It is used to alert you to potential personal injury hazards. Obey all safety messages that follow this symbol to avoid possible injury or death.</p>
	<p>DANGER (red) indicates an imminently hazardous situation which, if not avoided, will result in death or serious injury.</p>
	<p>WARNING (orange) indicates a potentially hazardous situation which, if not avoided, could result in death or serious injury.</p>
	<p>CAUTION (yellow) indicates a potentially hazardous situation which, if not avoided, may result in minor or moderate injury.</p>
	<p>CAUTION (yellow) used without the safety alert symbol indicates a potentially hazardous situation which, if not avoided, may result in property damage.</p>

fig01453

Table of Contents

About Your Water Pump	4
Summary of Important Safety Information	5
During Assembly	
During Operation	
During Storage / Troubleshooting	
Warning Label Locations	6
Unpacking	8
Assembly	9
Machine Components	10
Operation	
Operation - Preparing the Water Pump for Each Use	
Step One: Inspect/Repair	11
Step Two: Select a suitable site	12
Step Three: Fueling	15
Step Four: Attach a suction strainer	17
Step Five: Place the water pump	17
Operation - Using the Water Pump	18
Storage	20
Troubleshooting	21
Specifications	22
Water Pump Exploded View	23
6105348 Pump Exploded View	24
Engine Exploded View	25
Engine Operation/Specs	28
Engine Maintenance	29
Engine Storage	32
Limited Warranty	33
California Proposition 65 Information	34

About Your Water Pump

Thank you for purchasing your Powerhorse water pump!

About Your Water Pump

This water pump is a machine designed for outdoor, agricultural, general purpose water pumping, field irrigation and trash pumping applications.

This water pump is capable of handling suspended spherical solids, up to a capacity determined by the model.

- Up to 3/4" solids.

The technical specifications for your water pump are provided in the "Specifications" section of this manual.

Follow all safety precautions presented throughout this manual. A summary of important safety information can be found at the end of the manual.

Contact Powerhorse Product Support at 1-866-443-2576 for any questions about the appropriate use of this water pump and/or optional accessories.

Warranty Registration:

Please fill in the warranty registration information found in the back of this manual and have it on hand when you call in on a warranty claim.

Attention: All Rental Companies and Private Owners who loan this equipment to others!

All persons to whom you rent/loan this water pump must have access to and read this manual. Keep this owner's manual with the water pump at all times and advise all persons who will operate the machine to read it. You must also provide personal instruction on how to safely operate the water pump and be available to answer any questions a renter/borrower might have.

Summary of Important Safety Information

WARNING

Read and understand this owner's manual completely before using the water pump.

Improper use of the water pump could result in serious injury or illness for the operator or nearby persons/animals, or cause damage to the environment.

LISTED BELOW is a summary of safety information of particular importance. See individual sections of this owner's manual for more details.

----- DURING ASSEMBLY -----

- **CHECK and TEST completed assembly** as directed in this manual. Serious injury could result from water leaks if water pump is improperly assembled.
- **DO NOT MODIFY** water pump design.

----- DURING OPERATION -----

- **INSPECT and PREPARE water pump before each use** as directed in this manual.
- **DO NOT USE flammable or corrosive chemicals** in the water pump.
- **FOLLOW INSTRUCTIONS for SAFELY FUELING the engine.** Gasoline is flammable and can explode. Always use caution when handling gasoline.
- Keep a fire extinguisher rated "ABC" nearby.
- **DO NOT START water pump until ready to spray** in order to avoid unintentional release.
- **SEE Troubleshooting section of this manual before attempting any repairs.** Wear personal protective equipment and follow safety instructions.

----- DURING STORAGE / TROUBLESHOOTING -----

- **PREPARE THE WATER PUMP FOR STORAGE** according to the instructions in this manual.
- **SELECT a well-ventilated STORAGE AREA** away from sources of heat, flame, or sparks. Gasoline vapors can ignite and cause a fire.
- **READ and FOLLOW the safety rules for troubleshooting / servicing** the water pump to avoid accidental exposure to chemical and risk of electric shock.

Warning Label Location

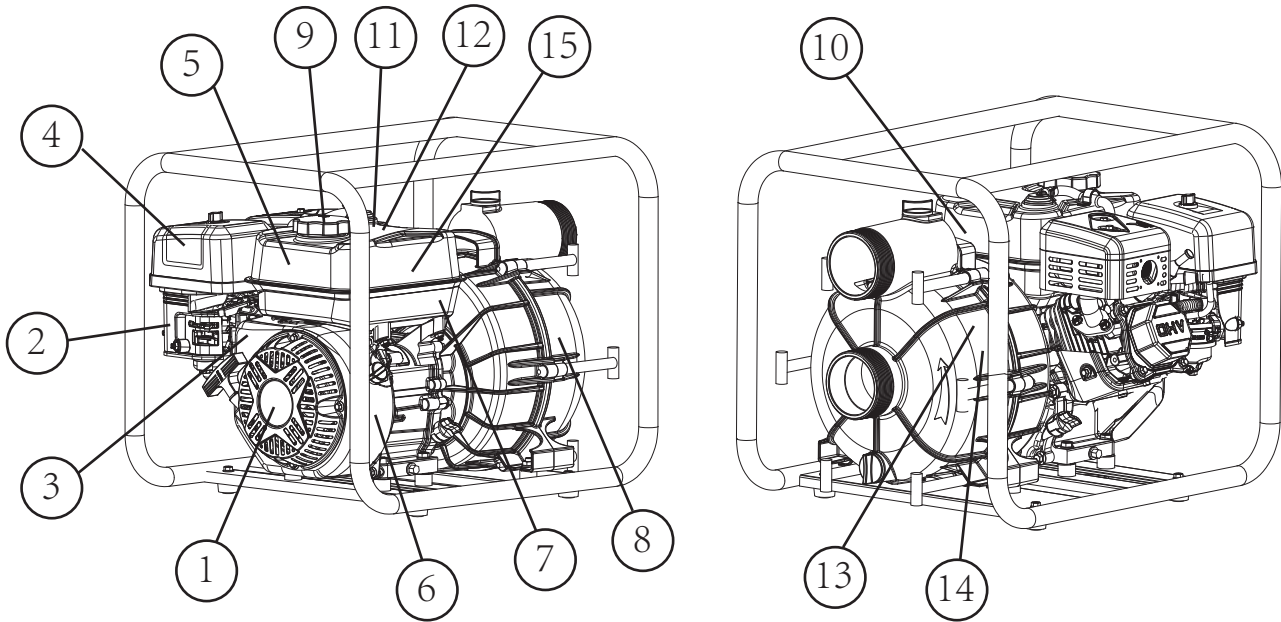

Ref. #	Part #	Description	Qty.
1	170427-1002	Powerhorse Recoil Decal	1
2	185350-1002	Choke Decal	1
3	178258-1002	Throttle Decal	1
4	185348-1002	Air Filter Decal	1
5	172630-1002	Powerhorse Logo Decal	1
6	132617-1002	EPA Decal	1
7	185334-1002	Oil Fill Decal	1
8	172634-1002	Name Plate	1
9	175394-1002	Danger Hang Tag	1
10	185356-1002	Hot Surface Warning Decal	1
11	172632-1002	E85 Caution Decal	1
12	167776-1002	Oil Level Warning Decal	1
13	161037-1002	Priming Warning Decal	1
14	161038-1002	Warning Decal	1
15	185340-1002	Warning Decal	1

Warning Label Location

1



2



3



4



5



6



7



8

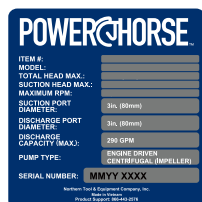

9

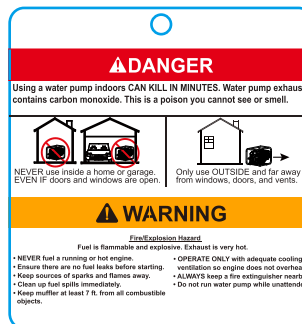

10



11



12

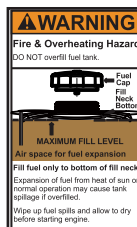

13



14

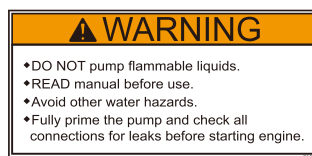

15

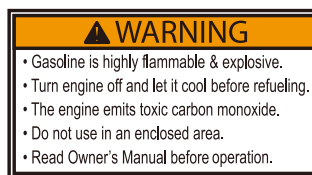

Machine Components

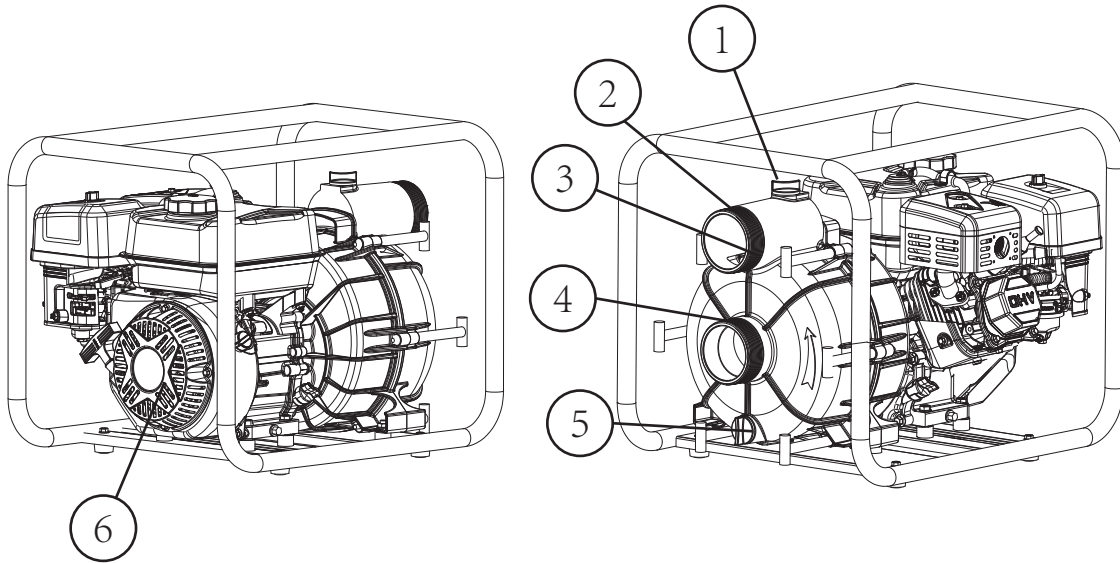

1. **Prime Port:** Fill the priming port to prime the pump.
2. **Discharge Fitting:** Connect the discharge hose to the discharge fitting.
3. **Pump:** The pump moves the liquid.
4. **Suction Fitting:** Connect the suction hose to the suction fitting.
5. **Drain Port:** Drain the liquid in the pump through the drain port.
6. **Engine:** The air-cooled engine powers the pump.

Operation – Preparing the Water Pump for Each Use

Step One: Inspect/Repair

If the water pump has been used previously, it must be prepared BEFORE EACH SUBSEQUENT USE.

 WARNING

Read instructions below carefully for inspecting and preparing the water pump.
 Damaged or clogged equipment could result in leaks or uncontrolled spray.

Important safety rules:

- **Turn off engine.** Turn off engine and remove spark plug cap before cleaning, inspecting, or servicing the water pump.
- **Guards / shields.** Make sure all guards and shields are replaced after servicing the water pump.
- **Replacement parts.** If a part needs replacement, only use parts that meet the manufacturer’s specifications. Replacement parts that do not meet specifications may result in a safety hazard or poor operation of the water pump.

1. Ensure water pump casing is empty	Ensure the water pump has been thoroughly flushed with fresh water and drained from prior use.
2. Clean suction strainer	Clean the suction strainer of any material residue. It is important to clean the suction strainer of debris before each use, to ensure it is not clogged.
3. Inspect & repair	Inspect and test the water pump thoroughly. <ol style="list-style-type: none"> a. Inspect fittings for cracks and leaks. Replace all damaged fittings with original Powerhorse parts. b. Check to be sure all nuts, bolts, and screws are tight. c. Check oil level in engine. See engine section of this manual. d. Check for fuel leaks. Any fuel leak is a fire hazard. Fix any fuel leaks before starting engine.

Operation – Preparing the Water Pump for Each Use

Step Two: Select a Suitable Site

⚠ WARNING

Choose a suitable site for operating your water pump to avoid equipment damage and/or injury and possible death from carbon monoxide poisoning, electric shock, or fire. Choose a site that meets all of the criteria specified.

Important safety rules:

- **Select a suitable site.** Before using the water pump, you must select a suitable **OUTDOOR** location for installation and operation. This location should meet all of the criteria listed below.

1. Level surface	<p>The water pump should be positioned on a firm and level surface. Ensure that the water pump sits level and will not slide or shift during operation. If applicable, block the water pump’s wheels to prevent sliding and shifting.</p> <p>Uneven ground can cause the engine oil level sensor to detect a low oil condition and stop the engine.</p>
2. Outdoors only	<p>Follow the directions below for choosing a location to operate your water pump in order to avoid carbon monoxide poisoning:</p> <ol style="list-style-type: none"> a. The location you choose to operate the water pump must be OUTDOORS and at least 20 feet from the home, away from windows, vents and air intakes, to allow proper ventilation. If you start to feel sick, dizzy, or weak while using the water pump, shut off the engine and get to fresh air RIGHT AWAY. b. Never run the water pump inside any closed or semi-enclosed spaces (even if outdoors), including homes, garages, basements, sheds, or boxes. <i>These spaces can trap poisonous gases, even if you run a fan or open windows.</i> c. Never place the water pump immediately adjacent to a building or other structures – allow at least 20 feet clearance. <p>WARNING: Carbon monoxide poisoning hazard The exhaust from your water pump contains carbon monoxide (CO), a poisonous gas that can kill. You cannot smell it, see it, or taste it. <i>Carbon monoxide exhaust is given off whether you are using gasoline, natural gas, or propane as the fuel source to power the water pump.</i></p>

Operation – Preparing the Water Pump for Each Use

<p>2. Outdoors only</p>	<ul style="list-style-type: none"> d. Place the water pump so that the muffler exhaust fumes will not be directed towards people or building air intakes. e. Ensure that working, battery-operated or battery back-up carbon monoxide alarms are used in any dwelling/structure that is in close proximity to the running water pump. <p style="margin-left: 20px;">WARNING: Never attempt to attach ductwork to the muffler system to allow for installation inside an enclosure. This could cause hot air deflection, heat build-up, and increased exhaust back-pressure, resulting in possible exhaust leakage or damage to the water pump.</p>
<p>3. Adequate cooling</p>	<p>The water pump needs adequate, unobstructed flow of air to allow for proper cooling of the engine and fuel tank. Follow the directions below:</p> <ul style="list-style-type: none"> a. Position so there is adequate clearance around water pump to allow for cooling airflow so that heat does not build up. b. Never place the water pump immediately adjacent to large objects or structures – allow at least a 7’ clearance. c. Do not run the water pump in close proximity to other heat-generating equipment, such as generators or other engine powered equipment. The combined heat that is generated may raise air temperature in the immediate area and there will not be adequate cooling ventilation. d. Do not allow debris to accumulate and block airflow to engine. e. Do not operate with a tarp, blanket, or cover surrounding the water pump.
<p>4. Hot exhaust clearance</p>	<p>The exhaust gas from your water pump is extremely hot and can cause combustible materials to catch on fire.</p> <ul style="list-style-type: none"> a. Make sure your water pump’s exhaust system is at least 7 feet from all combustible materials and structures. b. Keep a fire extinguisher rated “ABC” nearby. Keep it properly charged and be familiar with its use.

Operation – Preparing the Water Pump for Each Use

5. Hearing protection

The water pump can produce noise levels in excess of up to 95 dB in close proximity, which can be dangerous to human hearing with prolonged exposure.

WARNING:

Never attempt to attach ductwork to the muffler system to lower noise levels. This could cause hot air deflection, heat build-up, and increased exhaust back-pressure, resulting in possible exhaust leakage or damage to the water pump engine.

Operation – Preparing the Water Pump for Each Use

Step Three: Fueling

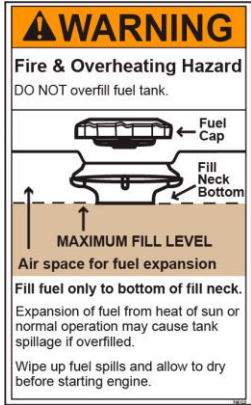
WARNING	
Gasoline is highly flammable and explosive. You can be burned or seriously injured when handling fuel. Use extreme care when handling gasoline.	
1. Engine off / cool	<p>The engine must be off and allowed to cool at least two minutes before adding fuel.</p> <p> WARNING: A running engine is hot enough to ignite fuel. Never add fuel or remove gas cap if engine is running or still hot.</p>
2. Outdoor location	<p>Fill fuel tank outdoors – never indoors.</p> <p> WARNING: Gasoline vapors can ignite if they collect inside an enclosure. Explosion can result.</p>
3. Check engine oil level	<p>Check engine oil level as specified in the engine section of this manual.</p>
4. Remove gas cap	<p>Remove engine gas cap.</p>
5. Add gasoline	<p>Add gasoline through fill opening from a UL-approved container.</p> <p><u>Important Safety Instructions:</u></p> <ul style="list-style-type: none"> Use approved container. NEVER pump fuel directly into engine at gas station. Static charge can build and ignite fuel. Use a UL approved fuel container to transfer gas to the engine. Don't overfill. DO NOT overfill the gas tank. Allow at least 1/2" of empty space below the fill neck to allow for fuel expansion Heat / flames / sparks. Stay away from sources of heat, flame, or sparks while adding fuel. <div style="text-align: right; margin-top: 10px;">  </div>
6. Spills / splashes	<p>Clean up fuel spills /splashes immediately.</p> <p>Move water pump away from spilled fuel on the ground.</p> <ol style="list-style-type: none"> 1. Wipe fuel off engine and wait 5 minutes for excess fuel to evaporate before starting engine. 2. Gas soaked rags are flammable and should be disposed of properly. 3. If gasoline is spilled on your skin or clothes, change clothes and wash skin immediately.
7. Replace gas cap	<p>Replace gas cap securely before starting engine.</p>
8. Gasoline storage	<p>Store gasoline in a cool, dry place in a UL approved, tightly sealed container.</p>

Operation – Preparing the Water Pump for Each Use

Static electricity and filling the gasoline tank:

Static electricity can initiate from ungrounded gasoline tanks or containers, from flowing gasoline, and from persons carrying a static electric charge

Static electricity can explosively ignite gasoline vapors that are present during the fueling process, resulting in serious burns to nearby persons. To avoid static electricity while fueling, certain steps must be followed before and during the fueling process in order to minimize and safely dissipate static charge build-up:

- ***Touch a grounded metal object before starting.*** Always dissipate static charge from your body before beginning the fueling process by touching a grounded metal object at a safe distance away from fuel sources.
- ***Use a portable container to fill tank.*** Never fill the water pumps gas tank directly from the fuel pump – the water pumps tank is not grounded and the high velocity flow of gasoline from a fuel pump can cause static electric build-up. Use an approved portable container to transfer gasoline to the water pumps tank.
- ***Fill container on the ground.*** Never fill the portable gas container while it is sitting inside a vehicle, trailer, trunk, or pick-up truck bed. ALWAYS place container on the ground to be filled.
- ***Keep nozzle in contact with container.*** Keep nozzle in contact with the portable container at all times while filling. Manually control the flow of gasoline; do NOT use the nozzle's lock-open device.
- ***Use a portable container made of metal or conductive plastic.*** It will dissipate charge to ground more readily.

About static electricity and fueling

Many common objects can accumulate and retain a static electric charge. Objects made of non-conductive materials (e.g. plastics) easily accumulate and retain static electric charge, as can objects made of conductive material (e.g. metal, water) if they are not electrically grounded. The static electric charge on an object, such as a human body or plastic fuel tank/container, can reach as high as several thousand volts!

A static electric spark can be generated if the static electric charge stored on an object “jumps” to another, less charged object. Such a spark can ignite invisible gasoline vapors that are present during fueling situations.

Typical sources of static electric hazards during fueling

The following objects can accumulate a static electric charge and cause an ignition spark in typical fueling situations:

- 1) **Ungrounded tanks/containers.** Any ungrounded fuel tank or container can accumulate a static electric charge as a result of contact with other objects or friction during transportation. This static electricity can discharge as a spark to the grounded gasoline dispenser nozzle, as the nozzle is first brought close to the tank/container at the beginning of the fueling process.
- 2) **Flowing gasoline.** Most people are not aware that gasoline accumulates static electric charge while flowing through a hose or pipe. This charge then transfers to and accumulates in the gas tank or container that is being filled. The total amount of charge accumulation depends on the amount of gas pumped into the container, the speed with which it is pumped, and whether or not the tank/container is grounded. If sufficient static electric charge accumulates in the fuel tank or container during the fueling process, the tank/container may discharge a spark to the grounded gasoline dispenser nozzle.
- 3) **Persons.** A person dispensing the gasoline can carry a static electric charge on their body, typically resulting from contact with their car seat or electronics. The static electricity can discharge as a spark between that person's hand and either the grounded dispenser nozzle or the fuel tank opening.

Operation – Preparing the Water Pump for Each Use

Step Four: Attach a suction strainer

⚠ WARNING	
This pump is design to pump water only. Never use the water pump to pump flammable liquids.	
1. Attach suction strainer	A suction strainer should be attached to the suction hose. A suction strainer has holes or slots small enough to prevent large debris from working through and damaging the pump.
2. Keep the strainer clean	Keep the strainer clean. If possible, suspend the strainer to keep it from working into sediment. -OR- A) Prepare a bed of large stones on which the strainer will rest. B) Tie the strainer inside a basket or pail.

Step Five: Place the water pump

1. Place the water pump near liquid surface	Place the water pump in a location as near to the liquid surface as possible, this will ensure proper pump suction. All hoses must be kept as straight as possible, avoid sharp bends. NOTE: 25ft is the maximum height of suction head.
2. Use flexible hose	Use at least 12” of flexible hose to make plumbing connections to the pump body. Rigid piping may put stresses on the pump, causing damage.
3. Place unit on secure footing	Always be sure the unit is on a secure footing. Keep the immediate pump area free of all unauthorized personnel. If the water pump is sitting beside a pit, be sure it is well anchored so that it does not fall in.
4. Do not run the pump dry	Do not run the pump dry. Always fill the pump body with water before starting. It is not necessary to drain the pump body after each use, unless there is danger of freezing, settling of solids, or crystallization.
5. Fill the pump with water	Fill the pump with water utilizing the priming port on the top of the pump. (The pump self primes only when it is first filled with priming water.) All hoses and pipe connections must be airtight.

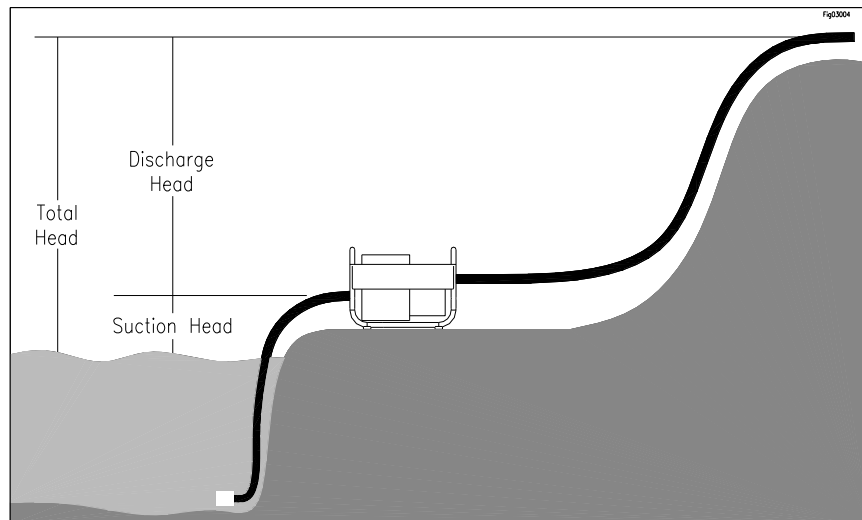

Operation – Using the Water Pump

Operate the water pump

1. Review safety information	Review the “Operation – Important Safety Information” provided in this manual.
2. Priming	Using the priming port on the top of the pump, completely fill the pump chamber with water before starting the engine.
3. Engine operation precautions	Heed the following safety rules with regard to running the water pump engine: <ul style="list-style-type: none">• Hot muffler. If you are starting a warm engine, stay clear of muffler. It may still be hot enough to burn you.• Hot exhaust. Hot exhaust fumes from engine can cause fire. Position muffler at least 7' from combustible objects during operation.• Fire extinguisher. Have a Class ABC fire extinguisher available as a precautionary measure when operating the water pump engine in dry areas.• Carbon monoxide. The running engine gives off carbon monoxide, a poisonous gas that can kill you. You CANNOT smell it, see it, or taste it. ONLY run the water pump engine OUTDOORS and away from air intakes. NEVER run the water pump engine inside homes, garages, sheds, or other semi-enclosed spaces. These spaces can trap poisonous gases, EVEN if you run a fan or open windows. If you start to feel sick, dizzy, or weak while using the water pump, shut off the engine and get to fresh air RIGHT AWAY. See a doctor. You may have carbon monoxide poisoning.

Operation – Using the Water Pump

4. Start engine	<p>To start the engine:</p> <ol style="list-style-type: none"> 1) Turn the gasoline line valve to the ON position. 2) For cold engine, move choke lever to full choke position. To restart a warm engine, move choke lever to half choke or to RUN position. 3) Start the engine: <ol style="list-style-type: none"> a) <u>Using recoil start</u> – <ol style="list-style-type: none"> i) Turn the engine switch to the ON position. ii) Pull the starter grip lightly until you feel resistance, then pull the starter cord out briskly and rapidly. iii) Allow starter cord to return slowly. 5) When engine starts, move choke lever to RUN position. 6) Under long, continuous-run operating conditions, be prepared to: <ol style="list-style-type: none"> a) Check and refuel the engine on a regular basis. <p style="text-align: center;">WARNING: A running engine is hot enough to ignite fuel. Never add fuel or remove gas cap if engine is running or still hot. Let cool at least 2 minutes.</p> <ol style="list-style-type: none"> b) Check engine oil level each time you refuel. c) Change oil after the first 20 operating hours, and at least every 100 operating hours thereafter, as directed in the engine section of this manual. <p style="text-align: center;">WARNING: Never open oil port while engine is running. Hot oil can spray over face and body.</p>
5. Throttle control	<p>When operating the water pump much higher than the water surface, you may need to speed up the engine, using the throttle. When the pump is near the water surface, a slower engine speed can be used. This will save engine fuel and life.</p>
6. Secure flexible hose	<p>Never allow a vehicle to run over the flexible hose. This sudden shut off pressure can cause “hydraulic shock”.</p> <p>If your flexible hose must be laid across a high traffic area, it is advised to protect the flexible hose with planking.</p>
7. Keep pump from freezing	<p>Never allow water to freeze in the pump. Freezing water can be extremely dangerous to the pump, always drain the water from the pump if freezing temperatures are a factor.</p>
8. Flush the pump	<p>Flush the pump with fresh water after each use is advised. Some liquids being pumped may leave a solid or sticky residue. This may shorten the life of your pump.</p>

Storage

Prepare the water pump for end-of-season storage by running pure water through the system. This will flush out any contaminants and clean the water pump internals. After the water pump has been flushed with pure water, completely drain the water pump of all water to protect from freezing.



WARNING

Gasoline vapors can ignite and cause a fire. Select a well-ventilated storage area away from sources of heat, flame, or sparks.

CAUTION

The water pump will be damaged if it freezes.
Protect the water pump from freezing during storage by following the instructions below.

Preparing for storage:

1. Pump pure water	Briefly run the water pump while pumping pure water.
2. Drain the water pump	Using the water pump drain plug, drain the water pump completely of water to prevent freezing.
3. Engine storage	<p>Refer to the engine section of this manual for proper engine storage instructions.</p> <p>- Always disable the engine for storage by unplugging the spark plug wire.</p> <p> CAUTION: Gasoline will oxidize and deteriorate in storage. Old gasoline in the engine will cause hard starting and leave gum deposits that can clog the fuel system. Deterioration problems may occur within a few months, or even less if gasoline was not fresh when you filled the fuel tank.</p> <p><u>Short-Term Storage:</u> Consider adding a fuel stabilizer to extend fuel storage life.</p> <p><u>Long Term Storage:</u> (between infrequent uses and at end of season) Drain the fuel tank and carburetor as instructed in the engine section of this manual.</p> <p><u>Important Safety Instructions:</u></p> <ul style="list-style-type: none"> • Always drain fuel from tank in outdoor, well-ventilated area. • Stay away from sources of heat, flame, or sparks while handling fuel. • Clean up fuel spills/splashes immediately.
4. Water pump storage location	<p>Store the water pump in a location away from corrosive material, sources of heat, open flames, sparks or pilot lights.</p> <p> WARNING: Never store water pump inside where there is a source of heat or an open flame, spark, or pilot light as on water heaters, space heaters, furnaces, clothes dryers, or other gas appliances EVEN IF the water pump's gas tank is empty.</p>
5. Gasoline storage	<p>Store gasoline in a cool, dry place in a UL approved, tightly sealed container.</p> <p> WARNING: Gasoline vapors can ignite if they collect inside an enclosure and an explosion can result.</p>

Troubleshooting

⚠ WARNING

Before troubleshooting or attempting to service, read the following safety rules.

Before attempting to service the water pump:

1. Review troubleshooting table	Review the Troubleshooting Table below for the type of problem you are experiencing. However, DO NOT attempt to repair until the steps listed below are followed.
2. Flush the pump	Pump pure water briefly to clean out the pump.
3. Drain the water pump	Drain the water pump completely of water using the water pump drain plug, to prevent freezing.
4. Disconnect power	Switch off the engine and unplug the spark plug wire.
5. Perform repairs	Follow the directions provided in the troubleshooting table to repair the water pump.

PROBLEM	CAUSE	SOLUTION
Pump doesn't revolve	1. Engine will not turn over	See engine section of this manual
	2. Rusting/Sticking of impeller	Disassemble and clean
Pump fails to prime	1. Priming chamber not full enough	Add more water to priming chamber
	2. Air leaks on suction line joints	Check for loose screws or broken hoses
	3. Quick coupling gaskets worn	Replace gaskets
	4. Loose or broken hose clamps	Tighten or replace hose clamps
	5. Priming chamber is over heated	Pour cold water in chamber or let cool
	6. Engine speed is too slow	Increase engine speed
	7. Worn or broken volute or impeller	Replace worn or broken component
	8. Worn or broken mechanical seal	Replace mechanical seal
	9. Worn or broken check valve	Replace check valve
Low capacity	1. Clogged suction hose	Clear obstruction
	2. Dirty suction strainer	Clear suction strainer
	3. Flow restriction due to hose kinks	Straighten suction and discharge hoses
	4. Suction lift too high	Move pump closer to water surface
	5. Engine speed too low	Increase engine speed
	6. Worn or broken mechanical seal	Replace mechanical seal
	7. Reduced engine performance	See engine section of this manual
	8. Clogged impeller	Remove clog
	9. Worn impeller	Replace impeller

Specifications

6105348 – 3" Semi-Trash	
Engine	DH212
Suction & Discharge Size	3" NPT
Maximum Flow	290 GPM
Maximum Suction Head	25 FT
Maximum Total Head	79 FT
Maximum RPM	3800
Passable Solid Size	5/8"
Mechanical Seal	Silicon Carbide
Overall Dimensions (L x W x H)	22.2" x 20.3" x 21.5"
Dry Weight	69 lbs

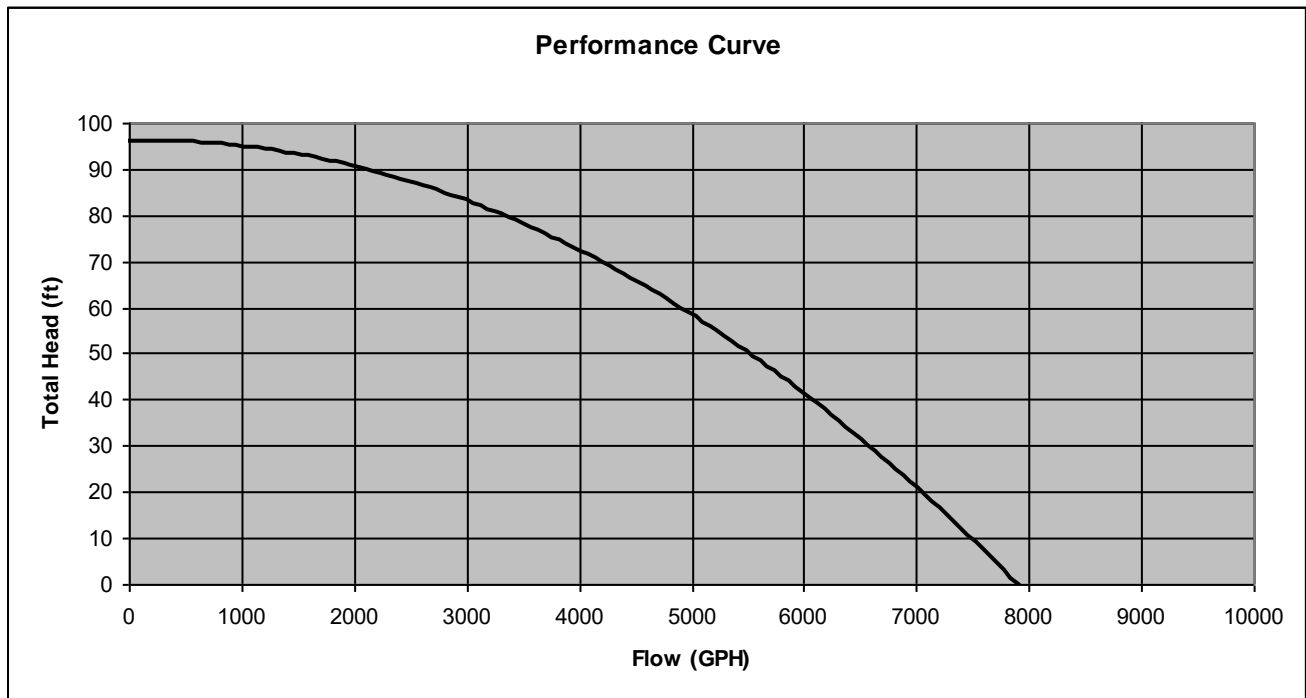

The manufacturer reserves the right to make improvements in design and/or changes in specifications at any time without incurring any obligation to install them on units previously sold.

Any Questions, Comments, Problems or Parts Orders
Call Powerhorse Product Support 1-866-443-2576

Engine Operation

⚠ WARNING

BEFORE operating the engine, be sure to read this section of the manual, otherwise injury to personnel or damage to equipment may occur.

Engine starting components

1. Fuel Valve
When the fuel valve is in the ON position, fuel is allowed to flow from the fuel tank to the carburetor. Be sure to return the fuel valve to the OFF position after stopping the engine.
2. Choke Lever
The choke is used to provide an enriched fuel mixture when starting a cold engine. It can be opened and closed by operating the choke lever manually. Move choke lever to the left toward CLOSED to enrich the mixture for cold starting.
3. Engine Switch
Turn the switch ON, and pull recoil to START. To stop the engine, turn the switch OFF.
4. Recoil
To start the engine, pull the starter rope lightly until resistance is felt, then pull briskly.
5. Throttle Lever
The throttle lever controls the engine speed. Pump output is controlled by adjusting the throttle lever.

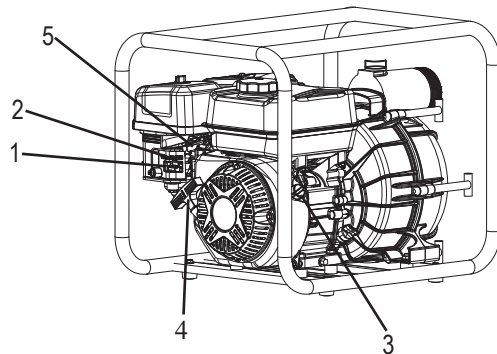

Displacement	212
Starting Type	Recoil Start
Ignition Type	Transistorized Magneto Ignition
Lubricating Type	Splash
Model	212cc
Spark Plug Gap	0.7~0.8mm (0.028~0.03in)
Spark Plug Torque	20-30N.m
Intake Valve Clearance	0.08~0.12mm (0.003~0.005in)
Exhaust Valve Clearance	0.13~0.17mm (0.005~0.007in)

⚠ WARNING:

Improper maintenance or failure to correct a problem before operation can cause a malfunction in which you can be seriously hurt or killed. ALWAYS follow the inspection and maintenance recommendations and schedules in this manual.

Engine Operation

Maintenance schedule	REGULAR SERVICE PERIOD	Before each use	First month or 20 Hrs.	Every 3 months or 50 Hrs.	Every 6 months or 100 Hrs.	Every year or 300 Hrs.	
	Engine oil	Check level	○				
		Change		○		○	
	Air filter	Check	○				
		Clean			○(1)		
		Replace				○	
	Fuel Valve Sediment Cup	Clean				○	
	Spark plug	Check-adjust				○	
		Replace				○	
	Spark arrester	Clean				○	
	Idle speed	Check-adjust				○(2)	
	Valve clearance	Check-adjust				○(2)	
	Cylinder head	Clean	After every 500Hrs. (2)				
	Fuel tank and filter	Clean	Every 2 years (Replace if necessary) (2)				
	Fuel tube	Check	Every 2 years (Replace if necessary) (2)				
	<ol style="list-style-type: none"> 1. Service more frequently when used in dusty areas. 2. These items should be serviced by an authorized service center, unless the owner has the proper tools and is mechanically proficient. 						
Engine oil recommendations	<p style="text-align: center;">CAUTION: Engine damage</p> <p>The water pump has been shipped WITHOUT oil. Any attempt to start water pump without oil may result in engine damage and failure.</p> <ul style="list-style-type: none"> • Engine oil is a key factor in deciding the engine's performance. DO NOT use engine oil with additives or 2-stroke gasoline oil, as they do not lubricate properly, which may shorten the engine's service life. • Check the engine oil level with the water pump stopped on a level ground. • Due to viscosity variances with regions and temperatures select the correct type of oil using the chart below. <p>Engine oil recommended: SAE10W-30</p> <p>Capacity: 0.42 Quarts (0.4L)</p> <div style="text-align: center;"> <p>The chart shows ambient temperature ranges for three oil grades: 5W-30 (from -30°F to 30°F), 10W-30 (from -20°F to 80°F), and 30 (from 0°F to 100°F). The x-axis is labeled 'TEMP' and 'AMBIENT TEMPERATURE' with scales in both Fahrenheit and Celsius.</p> </div>						

Engine Operation

Oil draining, and checking oil level

WARNING: Burn hazard

Never open oil port while engine is running. Hot oil can spray over face and body.

1. Operate the water pump for 3 to 5 minutes to thin oil for easier draining.
2. Ensure that the engine is stopped and on a level surface.
3. Remove the drain bolt and washer; drain the oil into an approved container.

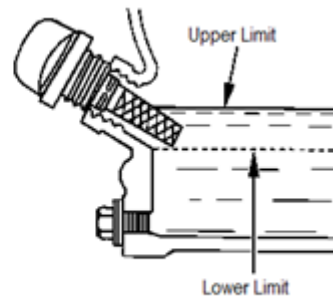
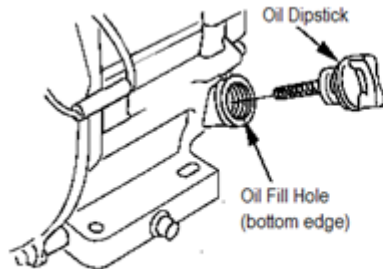
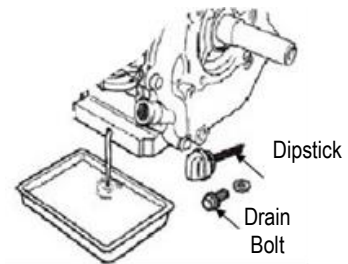

4. Reinstall washer and drain bolt.
5. Remove the dipstick and clean it.
6. Fill crankcase with oil to the bottom lip of the oil filler neck.
7. Reinsert the dipstick into the oil filler without threading in, and check oil level. If the oil level is too low, add recommended engine oil to the oil filler neck.
8. Reinstall the dipstick.

Spark plug removal, cleaning and replacement

Proper spark plug clearance ensures the engine's normal running.

- a) Remove the spark plug cap.
- b) Remove the spark plug using the supplied spark plug wrench.

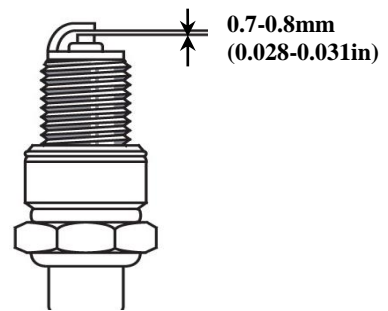
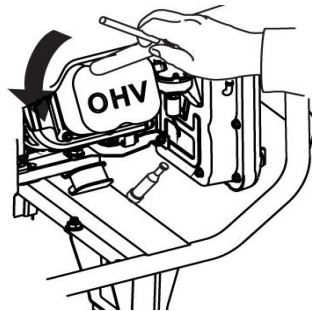

WARNING

Be careful not to touch the muffler during or just after the engine has been running.

- c) Clean the spark plug with a steel brush. If the insulator is damaged, replace the spark plug.
- d) Measure the spark plug clearance with a feeler. The clearance should be 0.7-0.8mm. If adjustment is necessary, bend the side electrode carefully.
- e) Check if the spark plug gasket is in good conditions, or replace with a new one. Screw on the spark plug to the bottom first by hand and then tighten it up by a spark plug wrench. If a new spark plug is used, twist 1/2 more turns after impacting the gasket; if reinstall the original one, just twist 1/8-1/4 more turns.

Engine Operation

Clean air filter

WARNING

Never run the water pump without the air filter. Rapid engine wear will result.

1. Remove the air cleaner cover and inspect the filter. Clean or replace dirty filter elements. Always replace damaged filter elements. If equipped with an oilbath air cleaner, also check the oil level.
2. Reinstall the air filter and air cleaner cover. Be sure all the parts shown below are in place. Tighten the wing nut securely.

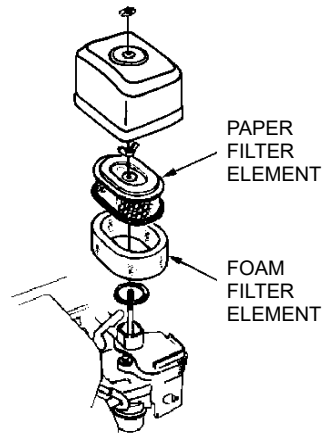

Note: Do not use pressurized air or solvents to clean the filter. Pressurized air can damage the filter and solvents will dissolve the filter.

Prepare engine for long term storage if needed

If you will not be able to exercise the water pump regularly, you must prepare the engine for long term storage to prevent gum deposits from forming and causing malfunction of the engine.

Prepare engine for long term storage by:

Removing all gasoline from the tank and carburetor.

Draining steps:

1. Position a UL approved fuel container below the carburetor drain bolt.
2. Turn fuel valve to the OFF position.
3. Remove the drain bolt and gasket.
4. Turn fuel valve to the ON position and drain fuel from carburetor and tank.
5. Reinstall and tighten the drain bolt and gasket.

OR

Adding fuel stabilizer to the gasoline (following manufacturer's instructions).

Fuel stabilizer steps:

1. Ensure gasoline tank is full.
2. Add fuel stabilizer to fuel tank.
3. Run engine at least 10 minutes after adding stabilizer to allow it to enter the fuel system.
4. Shut off engine.

Engine Operation

	<ol style="list-style-type: none"> 5. Disconnect spark plug wire and remove spark plug using provided spark plug wrench. 6. Add one teaspoon oil through spark plug hole. 7. Place rag over spark plug hole and turn starter (or pull the recoil) a few times to lubricate the combustion chamber. 8. Replace spark plug, but do NOT reconnect the spark plug wire. 										
<p>Removal from storage</p>	<p style="text-align: center;">WARNING</p> <p>Gasoline is highly flammable and explosive, and you can be burned or seriously injured when handling fuel.</p> <table border="1" style="width: 100%; border-collapse: collapse;"> <thead> <tr> <th style="text-align: left;">Storage time</th> <th style="text-align: left;">Service item</th> </tr> </thead> <tbody> <tr> <td>Within one month</td> <td>Use</td> </tr> <tr> <td>One-two months</td> <td>Drain original fuel and refuel.</td> </tr> <tr> <td>Two months - one year</td> <td>Drain original fuel and refuel; Empty and clean the fuel valve sediment cup. Empty and clean the carburetor bowl.</td> </tr> <tr> <td>One year or longer</td> <td>Drain original fuel and refuel; Empty and clean the fuel valve sediment cup; Empty and clean the carburetor bowl.</td> </tr> </tbody> </table> <p>Draining fuel:</p> <ol style="list-style-type: none"> 1. Turn the fuel valve to the OFF position. 2. Place a UL approved container below the carburetor; use a funnel to avoid spillage. 3. Remove the carburetor drain bolt and gasket. 4. Turn the fuel valve to the ON position to drain fuel into a UL approved container. 5. Reinstall and tighten the drain bolt and gasket. 	Storage time	Service item	Within one month	Use	One-two months	Drain original fuel and refuel.	Two months - one year	Drain original fuel and refuel; Empty and clean the fuel valve sediment cup. Empty and clean the carburetor bowl.	One year or longer	Drain original fuel and refuel; Empty and clean the fuel valve sediment cup; Empty and clean the carburetor bowl.
Storage time	Service item										
Within one month	Use										
One-two months	Drain original fuel and refuel.										
Two months - one year	Drain original fuel and refuel; Empty and clean the fuel valve sediment cup. Empty and clean the carburetor bowl.										
One year or longer	Drain original fuel and refuel; Empty and clean the fuel valve sediment cup; Empty and clean the carburetor bowl.										
<p>High Altitude Operation</p>	<p>CAUTION: Operating at an altitude of greater than 2000 feet (610 meters) may affect your engines performance, fuel consumption, and emissions. To remain emissions compliant and improve engine performance at higher altitudes, a high-altitude kit is required. A high altitude kit includes a carburetor jet resized to help correct air / fuel mixture at altitude. To order a high altitude kit or if you have additional questions, go to www.northerntool.com or contact us at 1-866-443-2576 – Powerhorse. Please note, engines with the high-altitude kit installed operated at lower altitudes could cause severe engine damage and affect emissions compliance. When modified, a tag or decal should be added to the product stating that a high-altitude kit was installed and to remind you to re-service the carburetor (re-jet) when operating in lower altitude environments.</p>										

6105348 Unit Exploded View

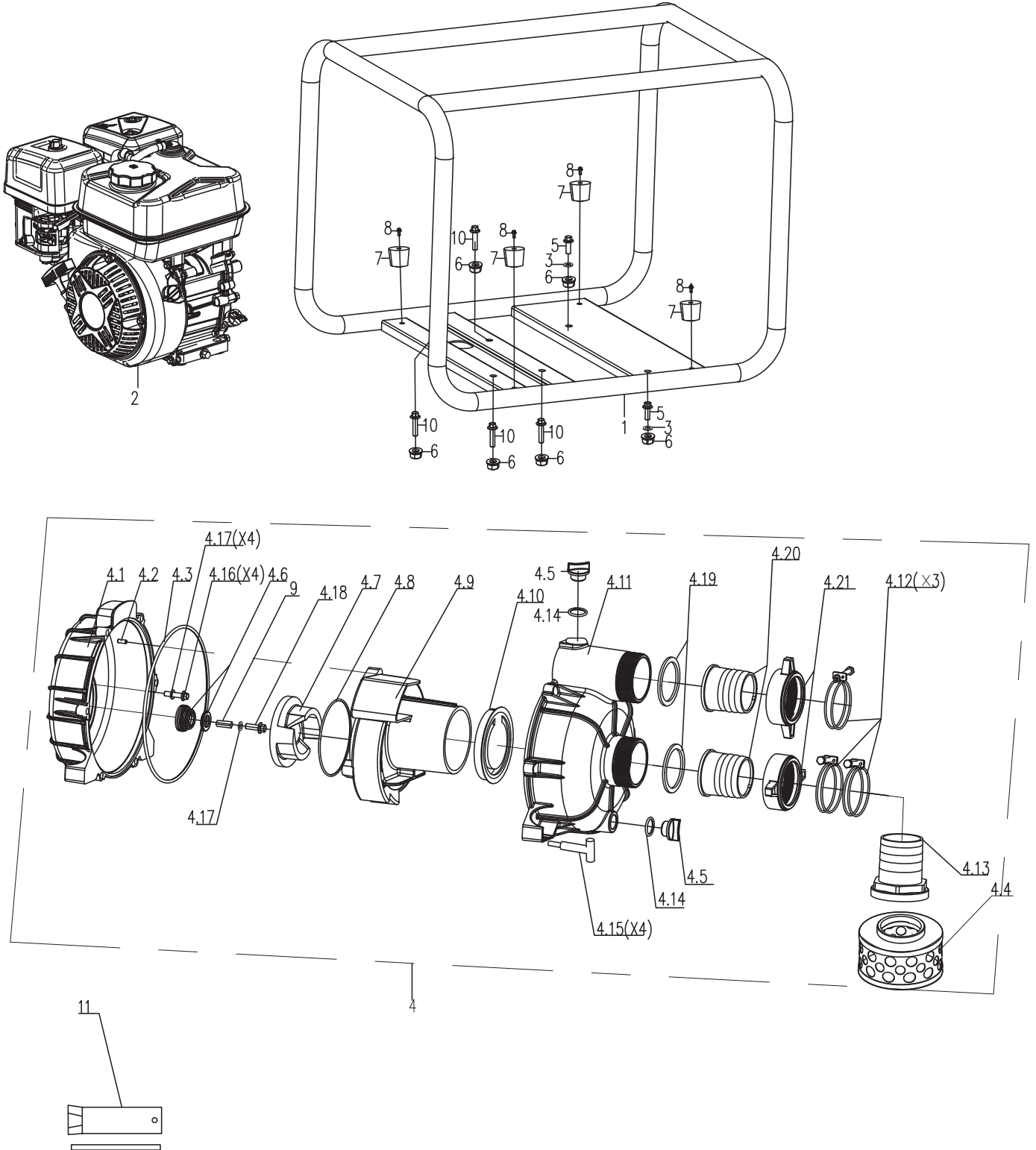

6105348 Engine Exploded View

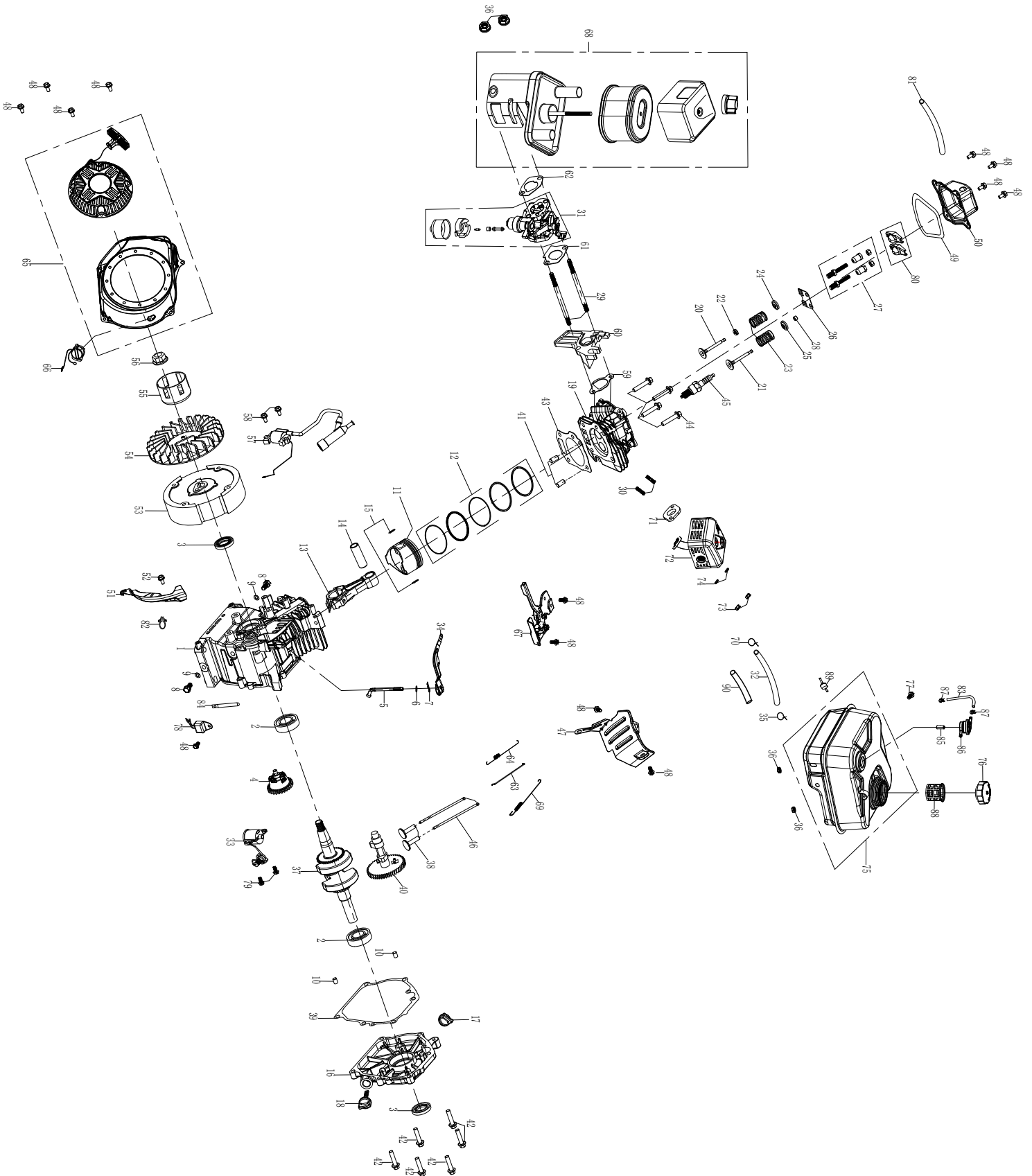

Limited Warranty

Dear Valued Customer:

The Powerhorse Product you just purchased is built with the finest material and craftsmanship. Use this product properly and enjoy the benefits from its high performance. By purchasing a Powerhorse product, you show a desire for quality and durability. Like all mechanical equipment this unit requires a due amount of care. Treat this unit like the high quality piece of machinery it is. Neglect and improper handling may impair its performance. Please thoroughly read the instructions and understand the operation before using your product. Always contact Powerhorse Product Support at 1-866-443-2576 prior to having any service or warranty work performed, as some services performed by parties other than Powerhorse approved service centers may void this warranty. This warranty is in lieu of any other warranty expressed or implied and Powerhorse assumes no other responsibility or liability outside that expressed within this warranty.

Limited Warranty

Powerhorse shall warranty any piece of equipment manufactured, or parts of equipment manufactured, to be free from defects in material or workmanship for a period of:

Powerhorse Warranty		
Item #	Consumer Warranty Period	Commercial Warranty Period
6105348	2 years from date of purchase by user	90 days from date of purchase by user

“Consumer use” means personal residential household use by a consumer. “Commercial use” means all other uses, including use for commercial, income producing or rental purposes or when purchased by a business.

This warranty applies to the original purchaser of the equipment (verification of purchase, in the form of a receipt, is the responsibility of the buyer), is non-transferable, and covers parts and labor. Parts will be replaced or repaired at no charge, except when the equipment has failed due to lack of proper maintenance. If a part is no longer available, the part may be replaced with a similar part of equal function. Any misuse, abuse, alteration or improper installation or operations will void warranty. Determining whether a part is to be replaced or repaired is the sole decision of Powerhorse. Powerhorse will not provide for replacement of complete products due to defective parts. Any costs incurred due to replacement or repair of items outside of a Powerhorse approved facility is the responsibility of the buyer and not covered under warranty. Transportation costs to and from service center is the responsibility of the customer.

In addition to the normal warranty, Powerhorse shall warrant any normal wear item from defects in material or workmanship for a period of 90 days from the date of purchase by user. Normal wear items include, but are not limited to, valves, seals, hoses, springs, O-rings, and strainers.

This warranty specifically excludes the following; failure of parts due to damage caused by accident, fire, flood, windstorm, freeze damage caused by improper storage, acts of God, applications not approved by Powerhorse in writing, corrosion caused by chemicals, premature seal failure caused by abrasive materials, use of replacement parts which do not conform to manufacturer’s specifications, damage related to rodent and/or insect infestation and damage caused by vandalism. Additional exclusions: loss of running time, inconvenience, loss of income, or loss of use, including any implied warranty of merchantability of fitness for a specific use. Also, Outdoor Power Equipment needs periodic parts and service to perform well, and this warranty does not cover instances when normal use has exhausted the life of a component or the engine.

This warranty does not cover any personal injury or damage to surrounding property caused by failure of any part. Repair or replacement of parts does not extend the warranty period.

The engine warranty is covered under the same terms and conditions as outlined above. Normal engine maintenance such as spark plugs, air filters, adjustments, fuel system cleaning and obstruction due to build up is not covered by this Powerhorse warranty.

Please fill in the following information and have it on hand when you call in on a warranty claim.

Tel: 1-866-443-2576

Website: www.northerntool.com

Please fill in the following information and have it on hand when you call in on a warranty claim.

Customer Number: _____

Date of Purchase: _____

Powerhorse Serial Number: _____

Item Number: _____

▲ WARNING: This product can expose you to chemicals including gasoline engine exhaust, which is known to the State of California to cause cancer, and carbon monoxide, which is known to the State of California to cause birth defects or other reproductive harm.

For more information go to www.P65Warnings.ca.gov.

POWER HORSE™

Distributed by
Northern Tool & Equipment
Company, Inc.
Burnsville, Minnesota
55306
www.northerntool.com
Made in Vietnam