

SPECIFICATIONS

GX270

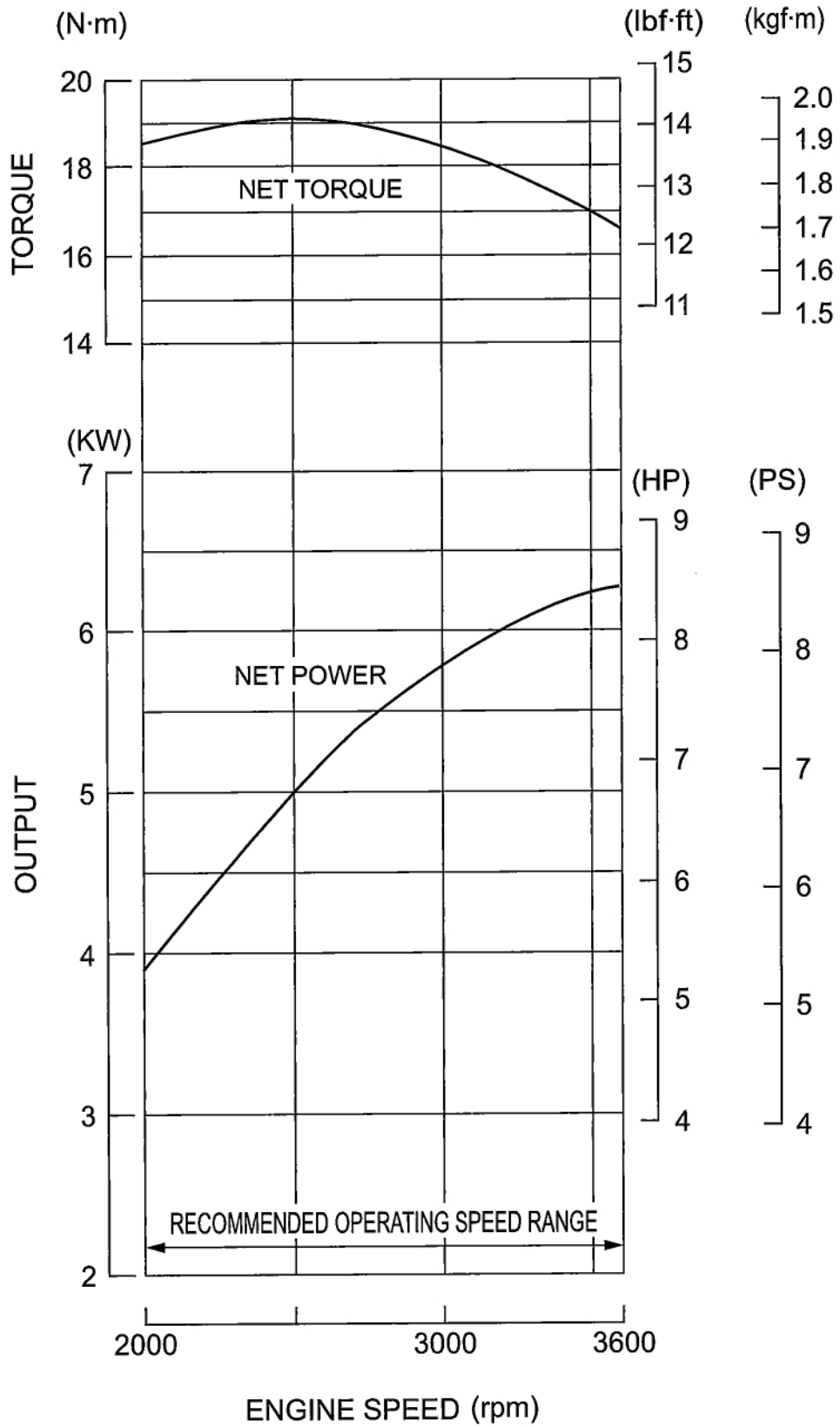

SPECIFICATIONS

GX270

WITHOUT REDUCTION UNIT TYPE

Unit: mm (in)

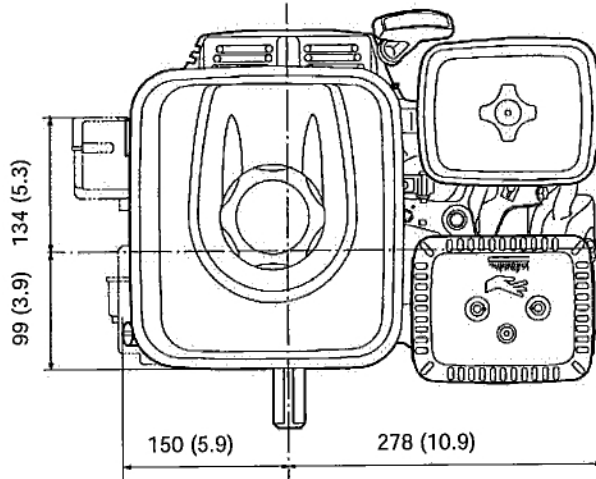

CONTROL BOX
(If equipped)

With control box type: 462 (18.2)

Without control box type: 428 (16.9)

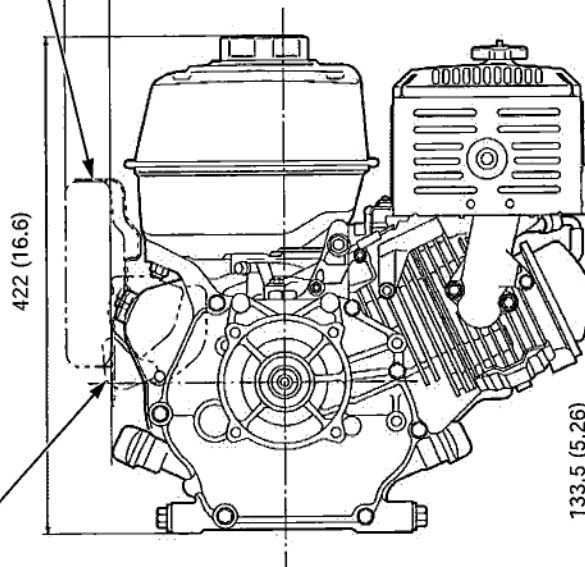

STARTER MOTOR
(If equipped)

CRANKSHAFT (P. T. O.)

116 (4.6)

192 (7.6)

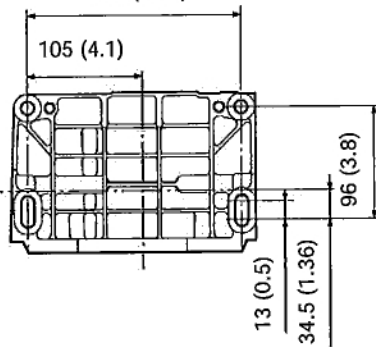
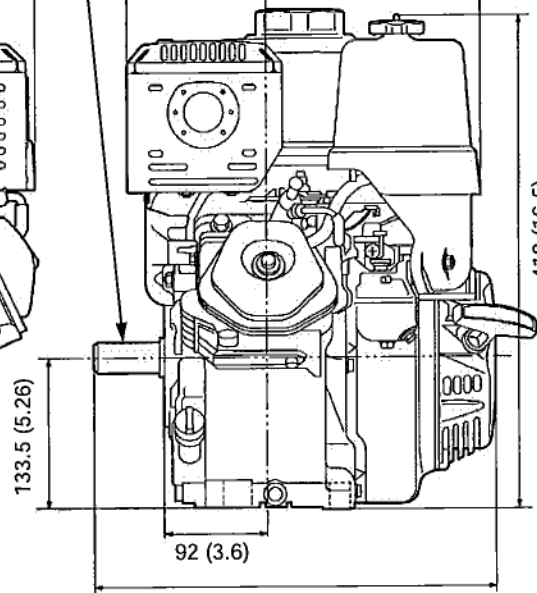

* P/Q:380 (15.0)

* V:400 (15.7)

SPECIFICATIONS

GX270

WITH REDUCTION UNIT TYPE

Unit: mm (in)

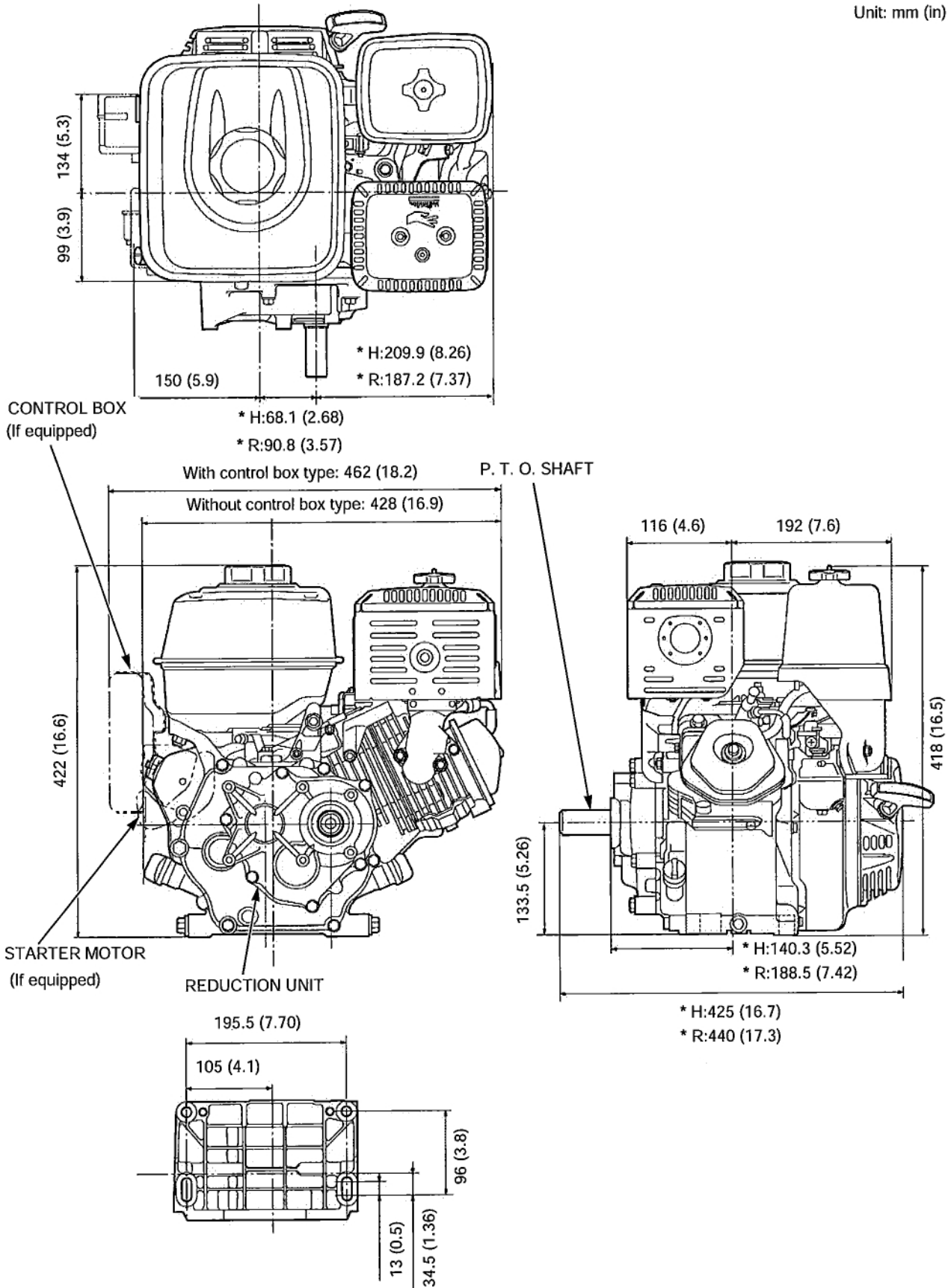

SPECIFICATIONS

GX270

*: P. T. O. type.

R TYPE* (WITH 1/2 REDUCTION UNIT)

Unit: mm (in)

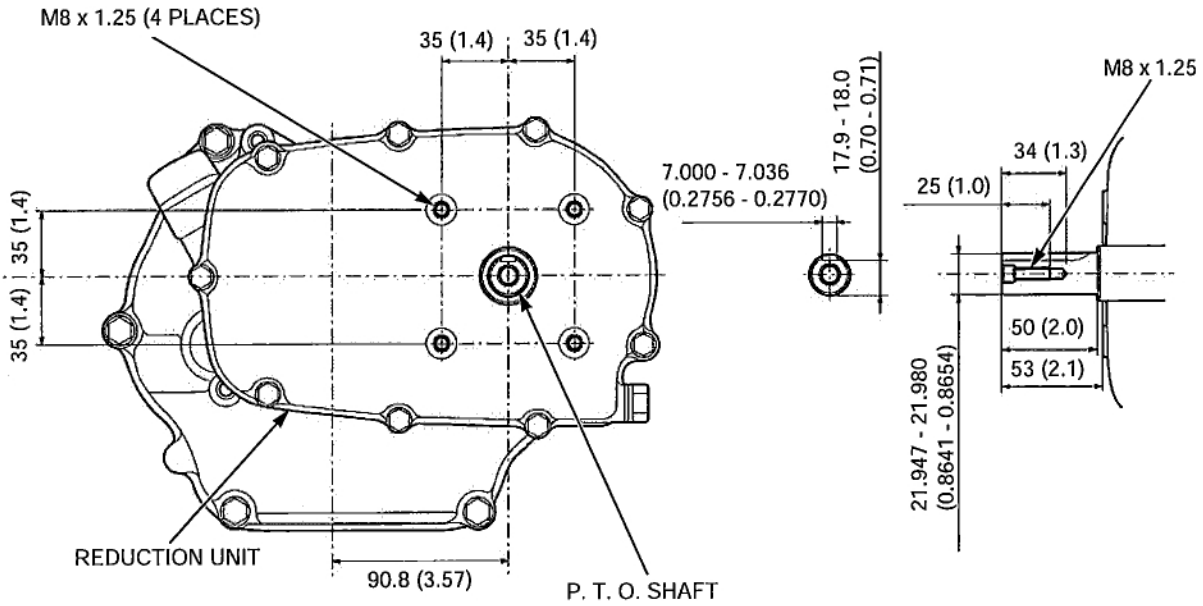

H TYPE* (WITH REDUCTION UNIT)

Unit: mm (in)

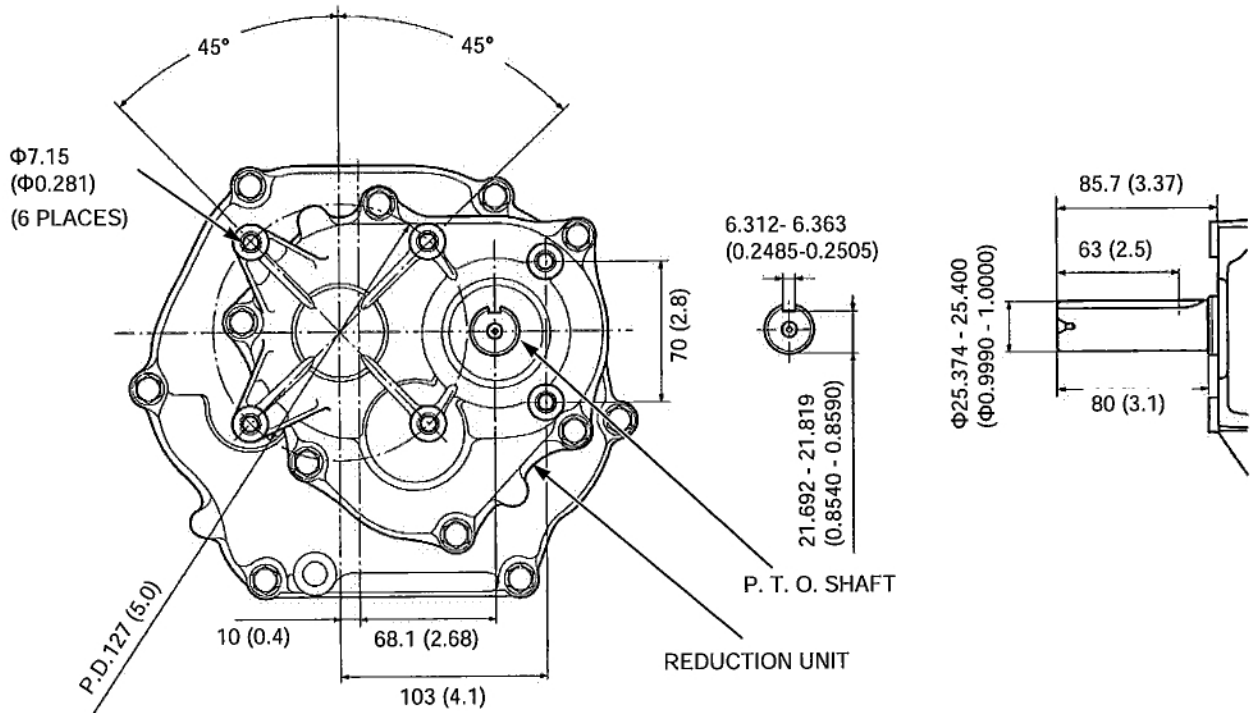

GX270

SPECIFICATIONS

P TYPE*

Unit: mm (in)

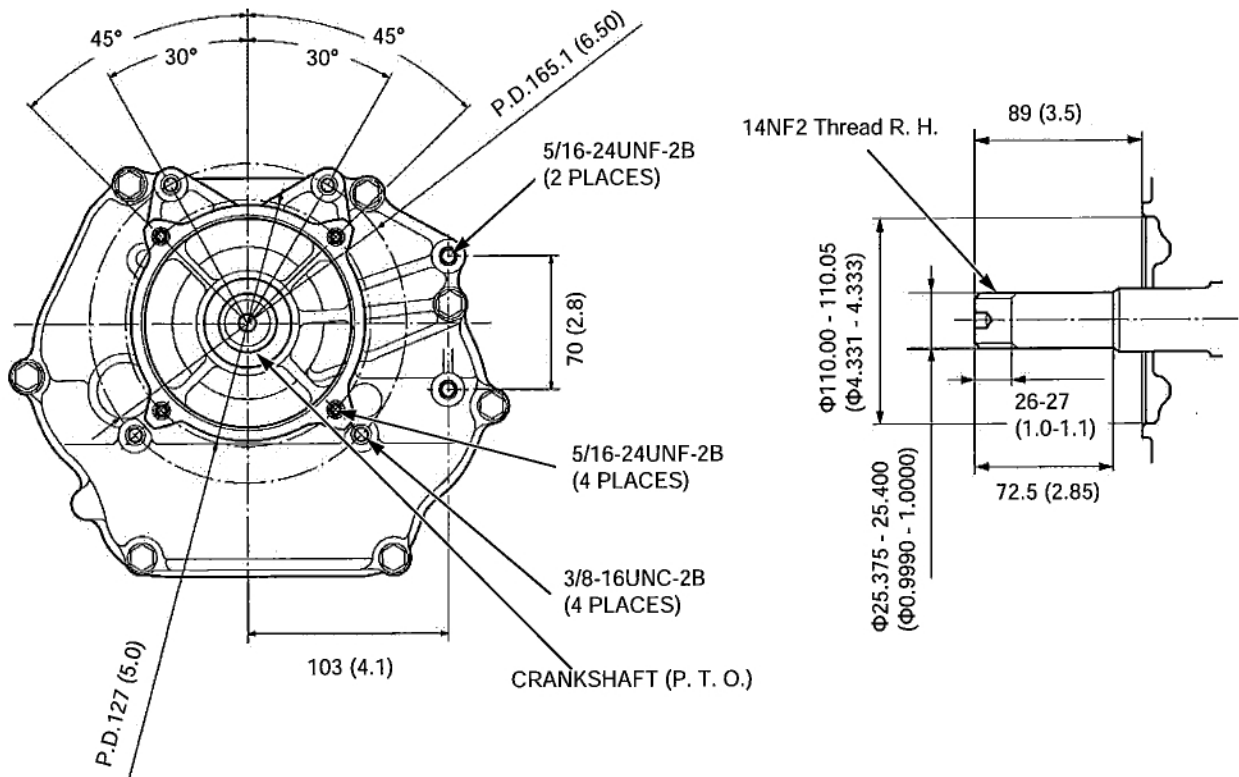

Q TYPE*

Unit: mm (in)

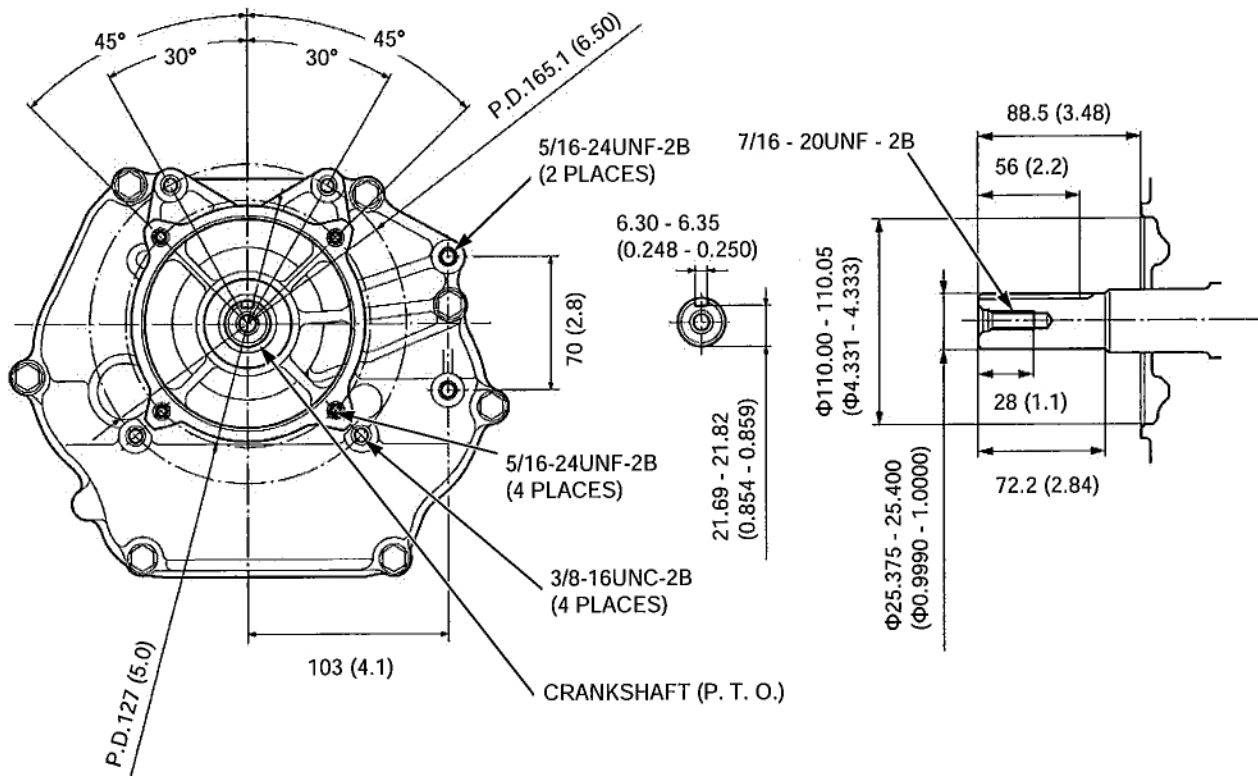

SPECIFICATIONS

GX270

V TYPE*

Unit: mm (in)

