

GX200

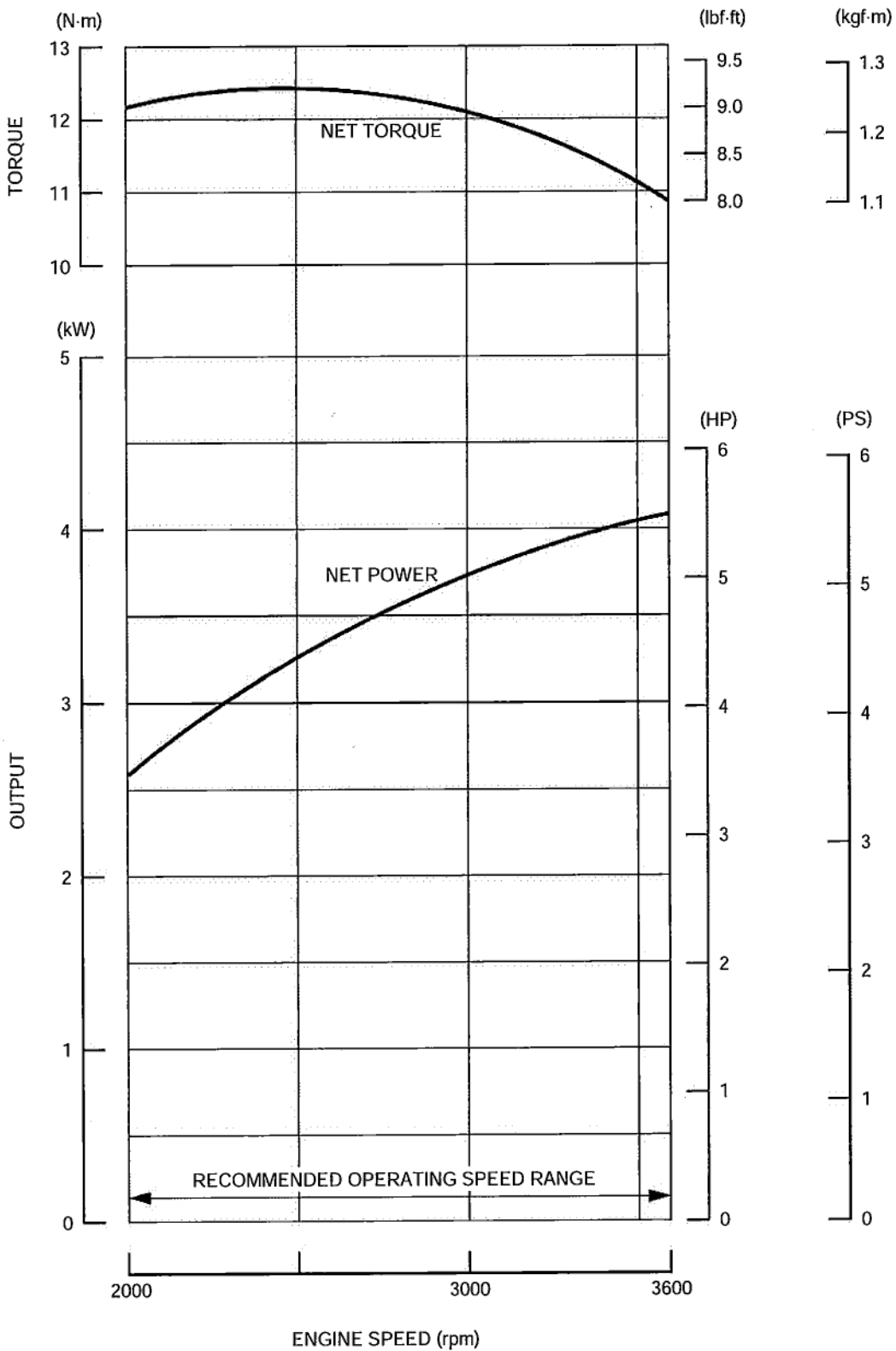

GX200UT2

SPECIFICATIONS

GX200 (WITHOUT REDUCTION)

Unit: mm (in)

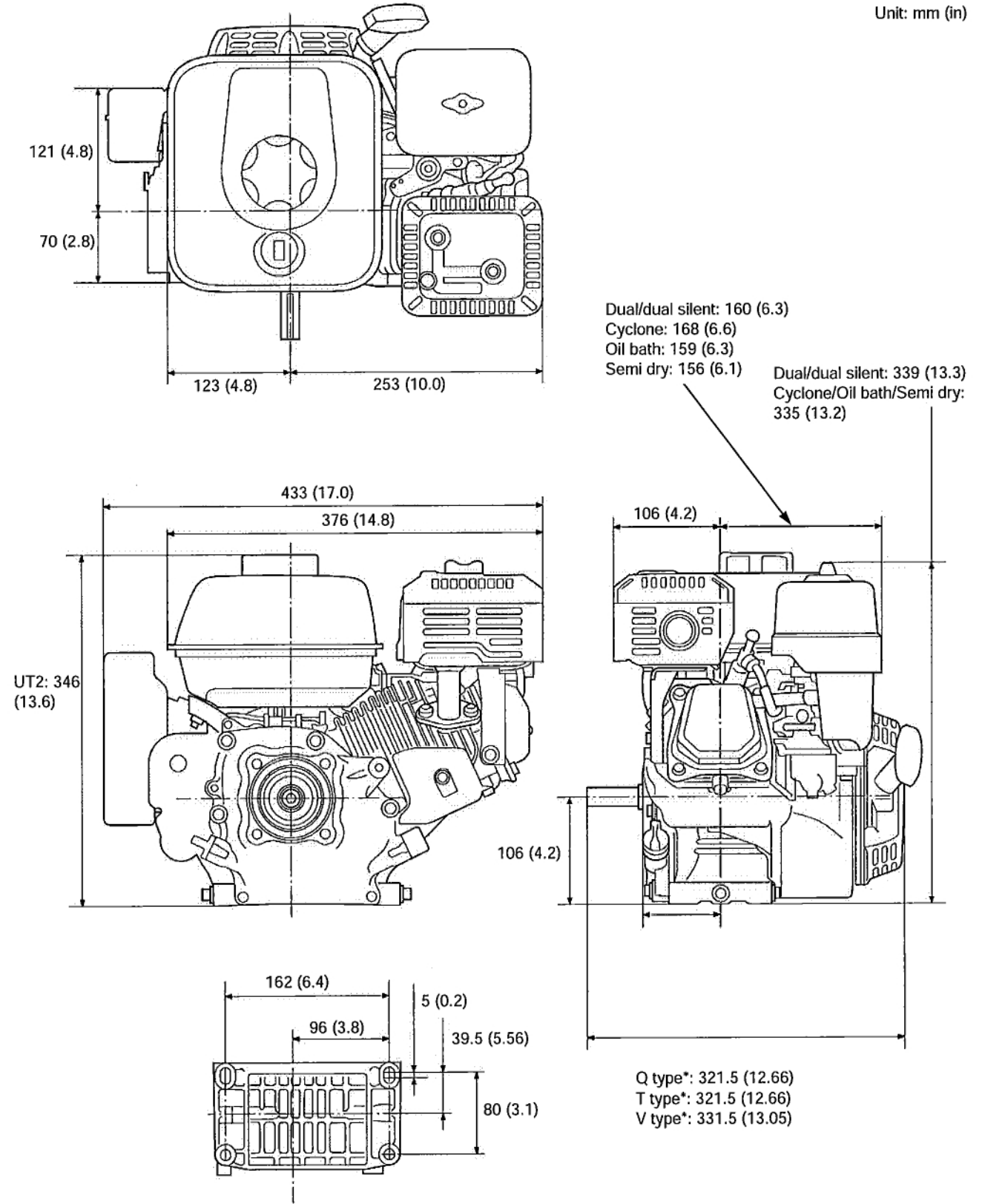

SPECIFICATIONS

GX200UT2

GX200 (WITH REDUCTION)

Unit: mm (in)

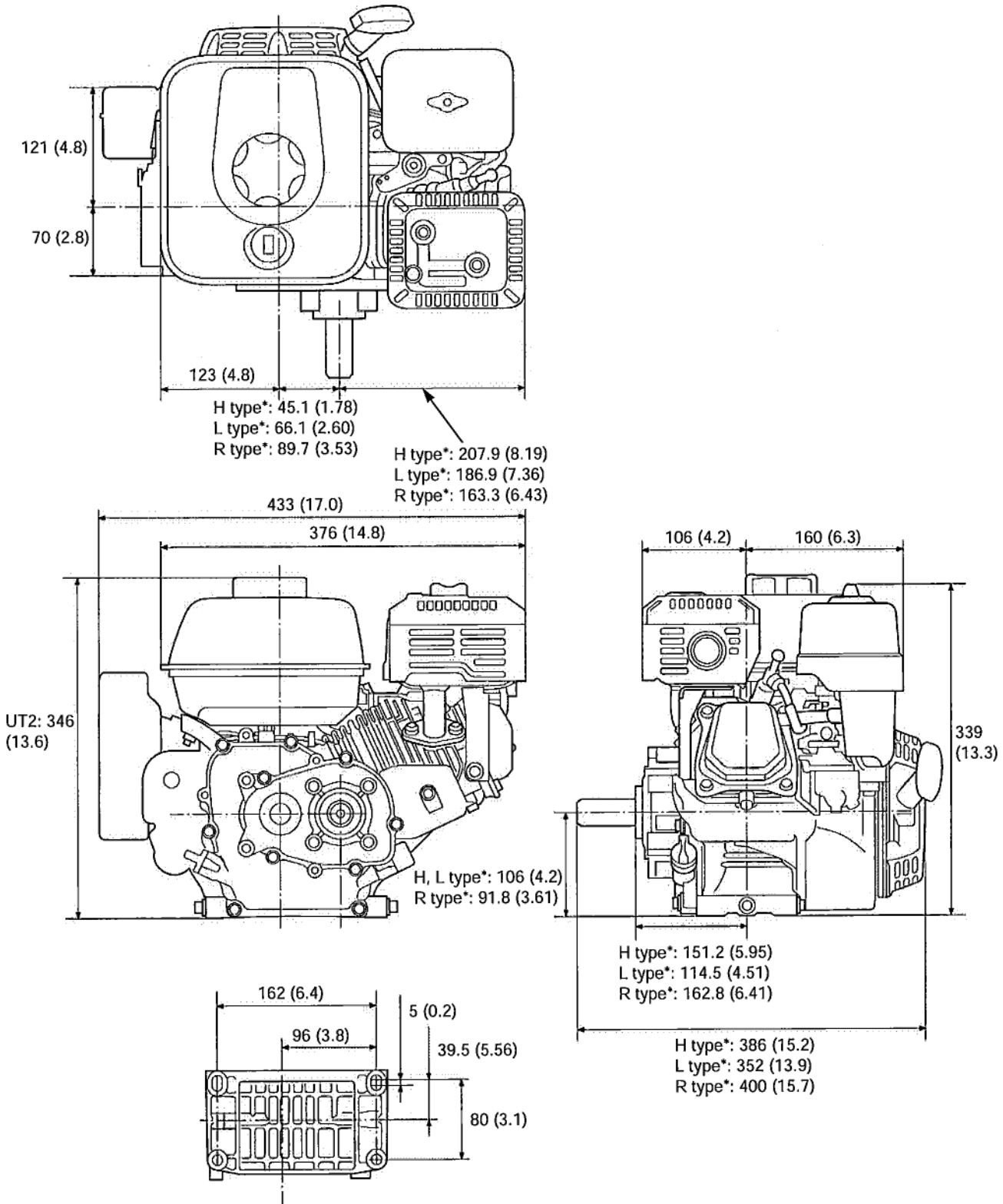

P.T.O. DIMENSIONAL DRAWINGS

*: P.T.O. type.

WITHOUT REDUCTION

Unit: mm (in)

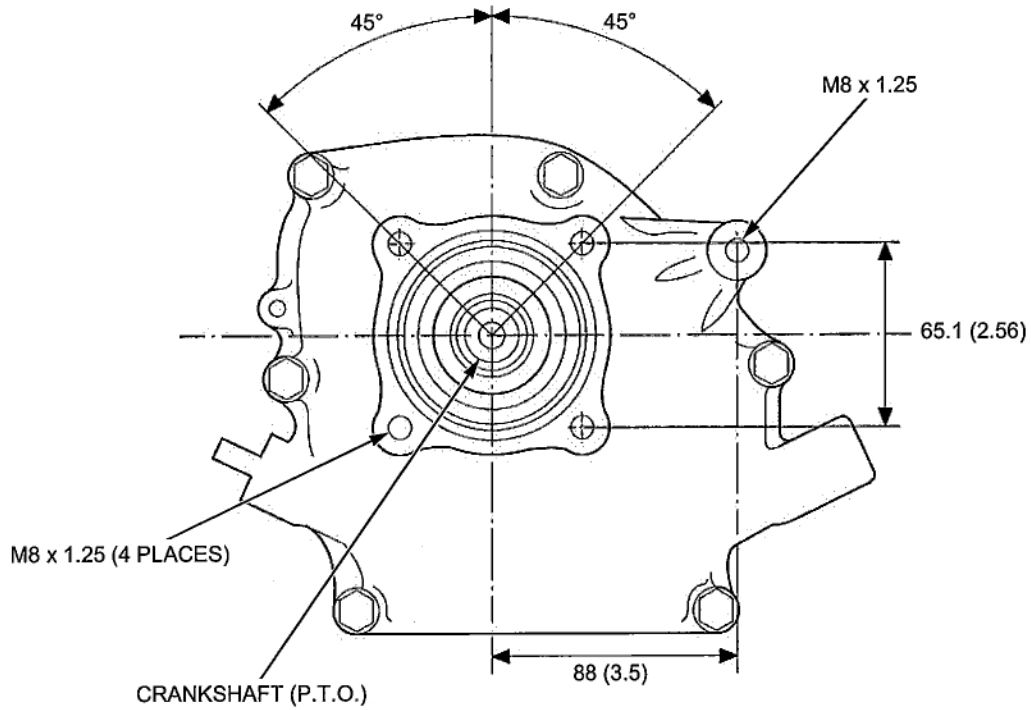

T type*

Unit: mm (in)

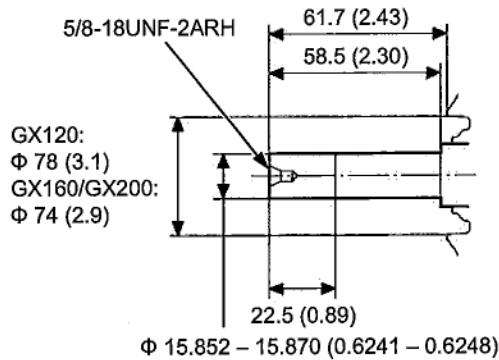

Q type*

Unit: mm (in)

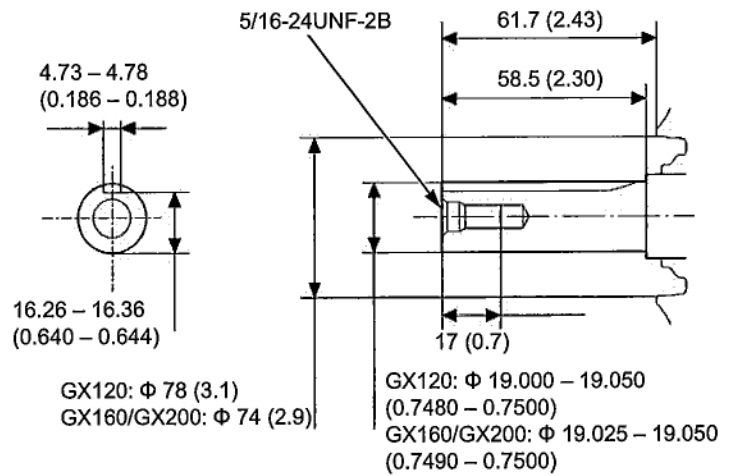

WITH REDUCTION

H type*

Unit: mm (in)

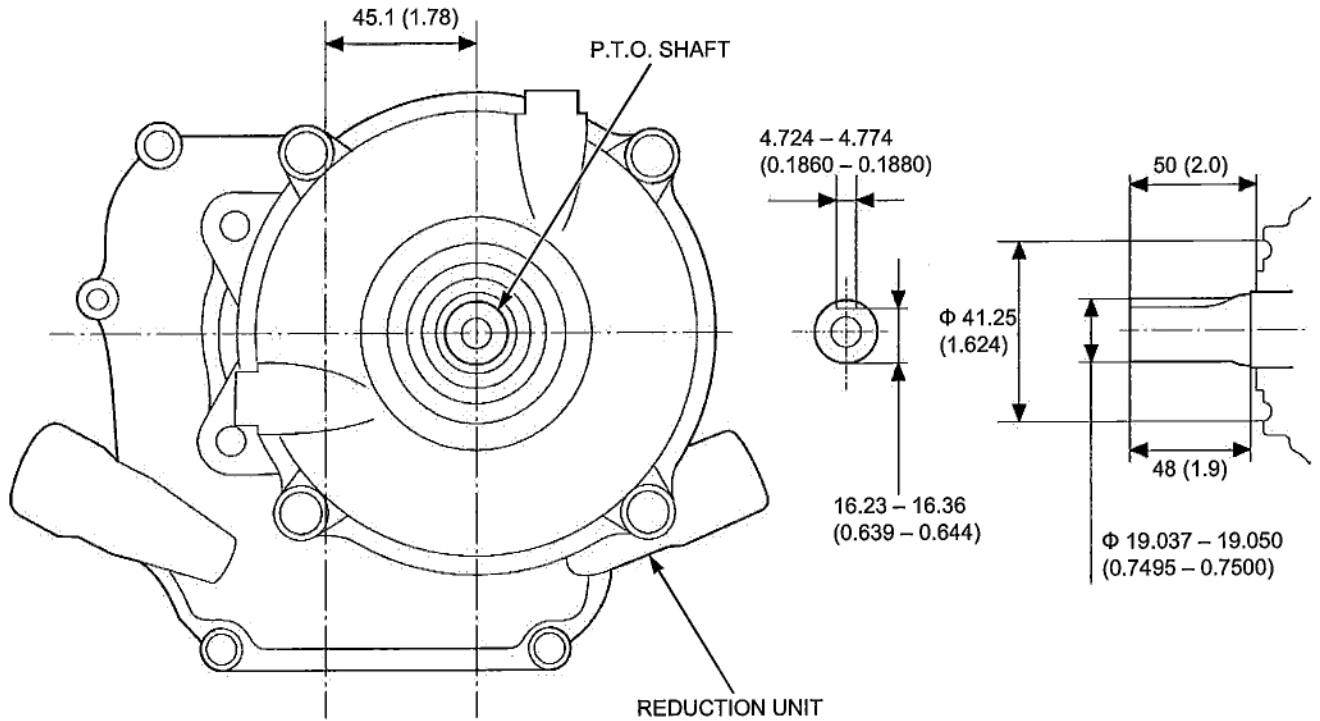

L type*

Unit: mm (in)

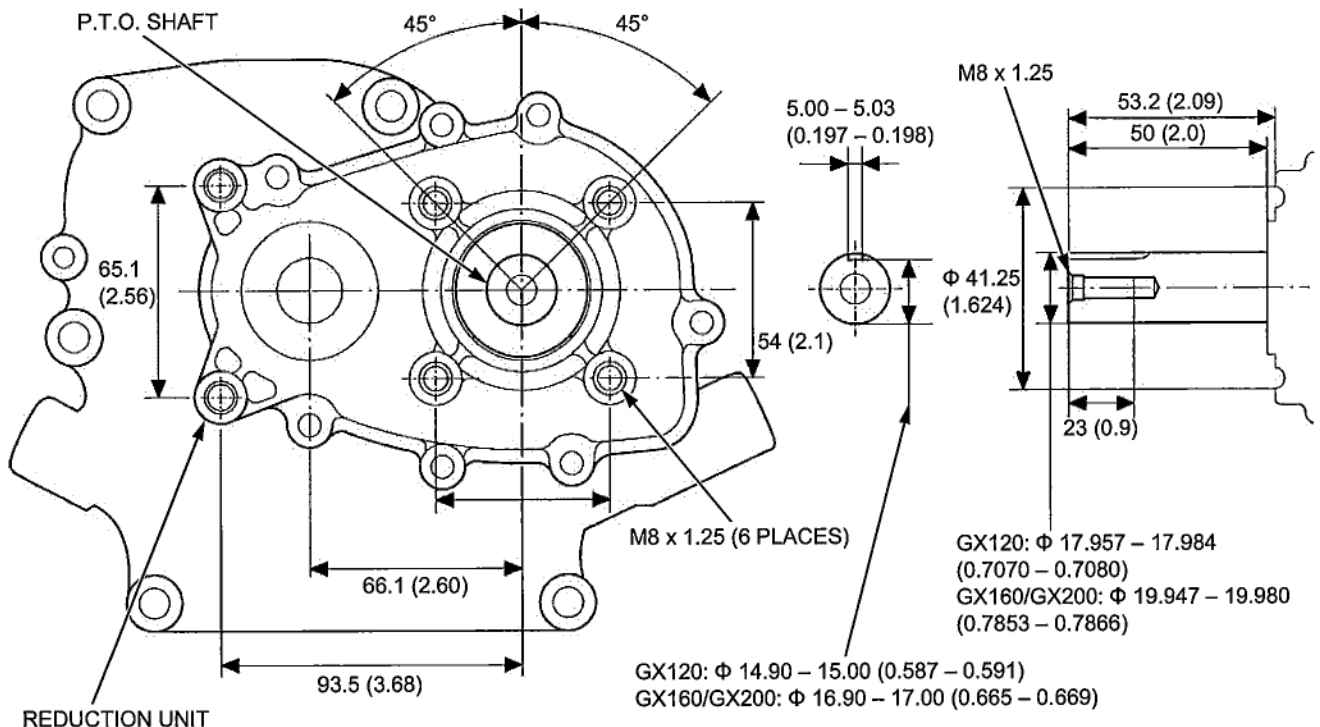

SPECIFICATIONS

GX200UT2

R type*

Unit: mm (in)

