

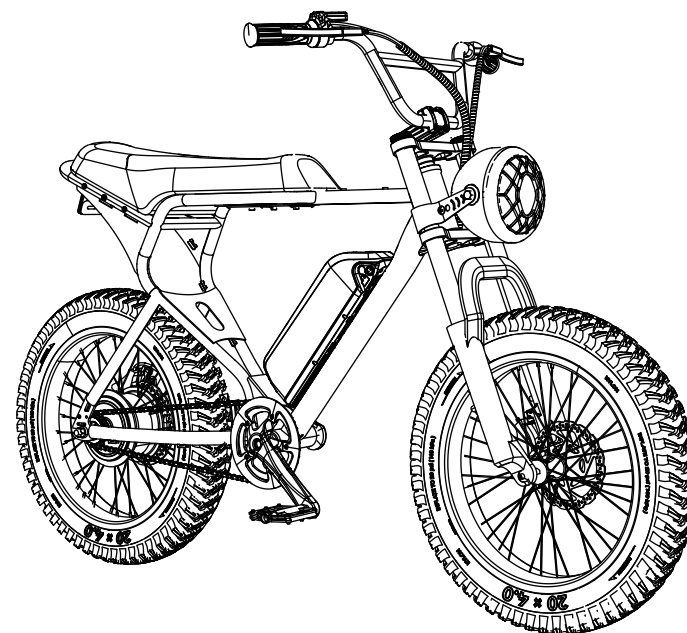

Company: E-LINK Technology Co., Ltd
ADD: 5 / F, Building B, No. 8, Shiyan Industrial Second Road,
Bao'an District, Shenzhen
Email: Support@e-linktech.com
Website: www.macfoxbike.com



MACFOX



OPERATION MANUAL

Model: EL-M20S

*THANK YOU
FOR YOUR
PURCHASE OF
THE E-BIKE.*

WARNING

The following operation manual is a guide to assist you. This manual is not a complete document on all aspects for the maintenance and repair of your bike. The electric bicycle you have purchased is not a complex object however, it is recommended that you consult an e-bike repair specialist if you have concerns as to your ability to assemble, repair, or maintain this product.

It is important for you to understand the electric bike. By reading this manual completely before the first ride, one will get better performance and enjoyment from this product; also it's helpful to extend the life of the electric bicycle.

This operational manual should remain an integral part of the product. Changes or any copy actions in pictures, specifications and descriptions are strictly prohibited.

What's in the box

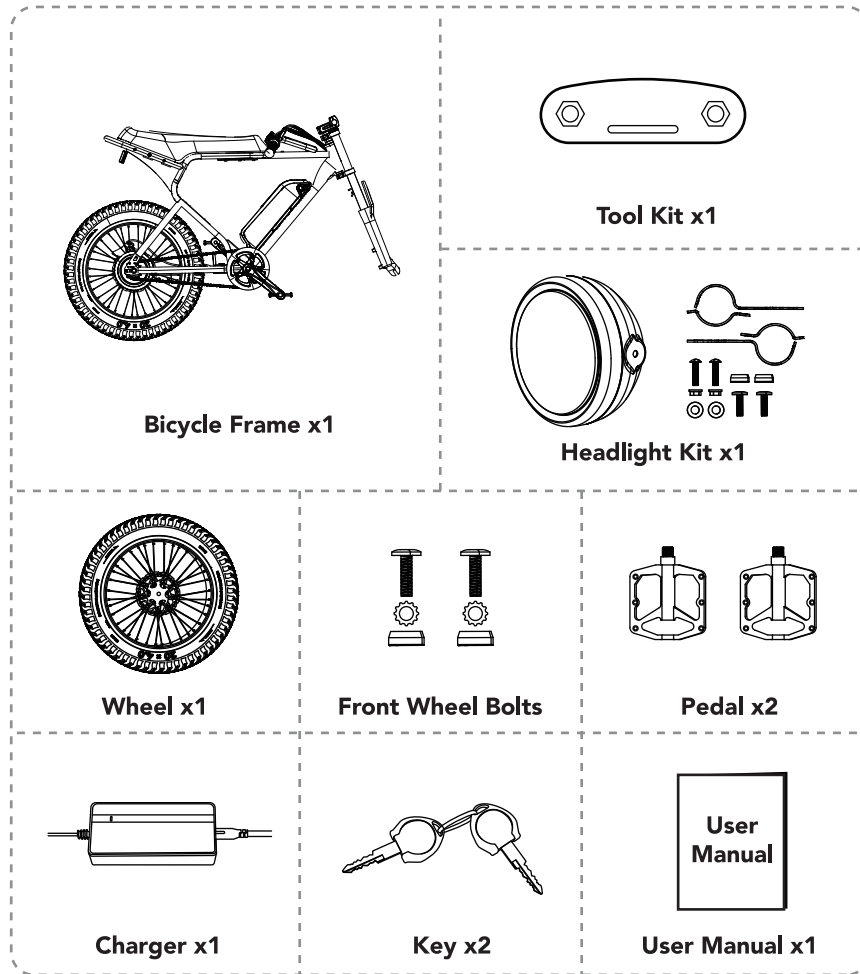

The pictures in the manual are just for reference. Please refer to the actual product for accuracy.

Safety Instructions

Motorized e-bikes are new to most riders so in the interest of safe cycling make sure you read, understand, and follow the instructions in this manual.

This manual contains important safety, signal words such as **DANGER**, **WARNING**, **CAUTION**, **IMPORTANT**, and **NOTE** or **NOTICE**. These are important signal words telling you to pay special attention to that text as rider safety is involved.

This symbol will appear in areas of critical rider safety.

Pay special attention to the words **DANGER** and **WARNING** as failure to do so can result in serious injury or death to the rider or others.

CAUTION notes will indicate instructions that need to be followed to prevent injury, mechanical failure, or damage to the e-bike. They also indicate a hazardous situation, which, if not avoided, can cause minor or moderate injury.

NOTE or **NOTICE** or **IMPORTANT** specify special interest notes. Pay close attention to these as your safety and that of your e-bike is involved.

IMPORTANT: Read the **BEFORE RIDING** section and check that all parts are working as stated in the manual. If you understand how the e-bike operates, you will ensure the vehicle's best performance. When you read this manual, compare the illustrations to your e-bike. Learn the location of all controls and parts and their functions. **KEEP THIS MANUAL FOR FUTURE REFERENCE.**

CAUTION: Before you ride the e-bike, check the brakes and other parts of the bike. Make sure all parts are assembled correctly, securely tightened, and working properly. Take your first ride in a large, open, level area away from traffic.

DO NOT RIDE YOUR E-BIKE WITHOUT FIRST SECURING AND FASTENING ALL HARDWARE CORRECTLY.

Make sure you read this complete manual before riding your e-bike. Failure to do so, or failure to follow its guidelines could lead to serious injury or death.

Brake pads and rotors get very hot during use and could burn skin. The edges can also be very sharp and cut skin. Do not touch the brake pads or rotors directly after riding your e-bike.

Proper use of your brake is vital to ensure safe, efficient stopping. To avoid misuse and potential injury, do not apply sudden or excessive force to your brakes. Apply your brakes gradually and give yourself enough room to come to a complete stop safely.

Different localities and countries have different laws governing riding on public roads, and you should check with local officials to ensure you are complying with these laws.

Brakes do not work as well under wet conditions as they do when dry. It is recommended that you do not ride your e-bike in wet weather, as there are electronic components of your e-bike that may be damaged if exposed to water.

Wet conditions will require a longer distance to stop. Brake earlier and avoid sudden stops when riding in wet conditions.

When you ride in low-visibility conditions such as fog, dusk, or at night, vision could be impaired, which could lead to a collision. Wear bright reflective clothing when riding in poor lighting conditions and use lights.

WARNING

There may be additional risk to injury if you use your e-bike incorrectly. This includes, but is not limited to:

- Riding e-bike over debris or obstacles
- Performing stunts
- Riding on off-road terrain
- Riding fast
- Racing other riders
- Riding in an unusual manner

The aforementioned examples add stress to each part of your e-bike and can lead to long term damage of the e-bike. Damage to your e-bike can lead to an accident or increase your risk of injury. To decrease your risk of injury, operate your e-bike correctly.

IMPORTANT

Do not ride the e-bike without the battery pack. The battery pack must be on the e-bike while riding or else the motor and safety lights will not function when needed.

Check to see that your wheels are securely fastened and that your helmet is securely fastened.

Protect the battery docking connector. When the battery pack is removed, apply a protective cover to prevent corrosion and damage to the connector.

Remove the battery pack from the e-bike and store it elsewhere in the vehicle during your transport.

Always respect local transportation laws when riding your e-bike.

Lithium battery packs of this size and power are considered "Dangerous Goods, Class 9." When transporting, regulations may restrict the transport of separate lithium batteries in some places.

WARNING!

Tampering or modifying the electric circuit system may cause a shock, fire or explosion and permanently damage the system. Exposed wiring and circuitry in the charger may cause electric shock. Always keep the charger housing closed.

Non-rechargeable batteries are not to be recharged.

WARNING!

SEEK IMMEDIATE MEDICAL ATTENTION IF YOU ARE EXPOSED TO ANY SUBSTANCE THAT IS EMITTED FROM THE BATTERY PACK.

This equipment is not intended to be used at ambient temperatures less than -20°C (-4°F) or above ambient temperatures of 55°C (131°F)."

The battery is intended to be charged when the ambient temperature is between 0°C (32°F) and 40°C (104°F)

SAFETY PRECAUTIONS

- If the e-bike is not to be used for an extended period of time, you may need to recharge the battery every 1 month to maintain the battery life.
- Ensure that the screws on the front and back tires are locked firmly before each ride.
- Check to ensure the tires are not worn..
- Check to ensure all connections are maintained on your e-bike.
- Ensure the brake cables are well lubricated. It is suggested you lubricate brakes every 6 months
- Ensure all gears move smoothly.
- Make sure there are no frayed cables, loose connections, missing fasteners or axle/lug nuts.
- For your safety, always wear a helmet that meets CPSC or CE safety standards. In the event of an accident, a helmet can protect you from serious injury and in some cases, even death.
- Obey all local traffic laws. Obey red and green lights, one-way streets, stop signs, pedestrian crosswalks, etc..
- Ride with the traffic, not against it.
- A crash can put extraordinary stress on your e-bike's components, possibly causing them to fail prematurely. Components suffering from stress fatigue can fail suddenly, causing loss of control, or serious injury.

CARE & MAINTENANCE

- Do not expose the e-bike to liquid, moisture, or humidity to avoid damage to the electrical system.
- Do not use abrasive cleaning solvents to clean the e-bike.
- Do not expose the e-bike to extremely high or low temperatures as this will shorten the life of the electrical system, destroy the battery, and/or distort certain plastic parts.
- Do not dispose of the e-bike in a fire as it may explode or combust.
- Do not expose the e-bike to contact with sharp objects as this will cause scratches and damage.
- Do not let the e-bike fall from high places, as doing so may damage the internal circuitry.
- Do not attempt to disassemble the e-bike.
- Use only the specified charger provided.
- Ensure the e-bike chain is well lubricated for optimal performance.
- To minimize tire wear and for maximum riding safety, comfort and handling, maintain recommended tire air pressure which can be found on the side wall of all tires. Use a reliable tire air pressure gauge to check for proper inflation before every ride. At the same time, inspect tires for excessive wear and cracks. Replace tires if necessary.

Preface

Congratulations on the purchase of your new e-bike! With proper assembly and maintenance it will offer you years of enjoyable riding!

IMPORTANT: Carefully read and follow this manual (and any other materials included with this bike) before riding. Please retain this manual for future use. If this bike was purchased for a child, it is the responsibility of the purchaser to verify the bike has been properly assembled, and that the user has been properly trained and instructed in use of the bike. This manual is provided to assist you and is not intended to be a comprehensive manual covering all aspects of maintaining and repairing your bicycle. The bicycle you have purchased is a complex piece of equipment that must be properly assembled and maintained in order to be ridden safely.

If you have any doubts about the assembly or your ability to properly assemble and maintain the bicycle. You must have it assembled and maintained by a professional bicycle mechanic.

WARNING: E-bikes are fun to ride but can be dangerous to use. The user or consumer assumes all risk of personal injuries, damage, or failure of the bicycle or system and all other losses or damages to themselves and others and to any property arising as a result of using the bicycle.

WARNING

DO NOT DISASSEMBLE, MODIFY OR REPLACE ELECTRICAL PARTS.

If you need to change any parts, please consult a professional bicycle mechanical or contact customer service for additional help.

NOTE: YOUR INSURANCE POLICIES MAY NOT PROVIDE COVERAGE FOR ACCIDENTS INVOLVING THE USE OF THIS BICYCLE. TO DETERMINE IF COVERAGE IS PROVIDED YOU SHOULD CONTACT YOUR INSURANCE COMPANY OR AGENT.

DANGER: Failure to properly assemble and maintain your bicycle could result in serious injury or death to the rider.

This manual contains important safety, performance and service information. The purpose of this manual is to help you use your e-bike safely in the manner intended and allow you to enjoy the benefits it offers for years to come. Please read it carefully before you take your first ride on your e-bike and keep it in a safe place for reference.

Owner Responsibility

IMPORTANT: Reading and following the information and instructions in this manual are essential to the ability of the owner or any other persons allowed to use this bicycle in order to ride safely.

1. It is the responsibility of the owner or in the case of a younger rider the parents of the rider to be certain all assembly instructions have been followed, even if the bike has been assembled by the seller, manufacturer, or a professional assembly company.
2. Brakes are essential to safety. Be sure they are checked and working properly before each use. Remember that any mechanical system changes condition during use and must be maintained and checked before each use.
3. Rules for bicycle use (bicycle laws) vary from location to location so be certain the rider knows and understands the rules that apply to bicycle usage in all areas where the bicycle will be used. Wearing a helmet, light or reflective clothing, using lights and reflectors are examples of rules which may exist and which make sense as rider safety precautions at all times.
4. Know how to operate the bicycle and all equipment on it before first use and be certain anyone allowed to use the bike knows how to properly and safely use the bike as well.
5. There are many different types of bicycles and often these types are designed for different uses. Make sure you know what type unit you have and do not exceed its service limitations. Be sure you check and understand the bicycle classifications set in this manual, including size of the unit that is proper for the rider to insure good control during use. Riders who are too small or large may have control problems. Do not overload a unit with a rider that is too heavy or too large, and do not attempt to carry extra passengers, packages or loads on the bicycle. Do not use street bikes for off road riding.
6. Your electric bike is water-resistant, but must be properly maintained to preserve this condition. Please do not submerge the bicycle or any electric components in water. Water entering electric components can cause a short circuit and damage the electric components with possible injury to the rider and others.
7. The battery's performance can be effected by its environment. Generally speaking, battery's discharge performance is better in a higher temperature. Electric power will drop by more than 1/3 when the temperature is below 32°F (0°C). Thus, this e-bike's riding distance per charge will become shorter in winter or cold areas. It returns to normal / optimal when the temperature is higher than 68°F (20°C).
8. Do not put any metal objects in charge hole or battery circuit, it may cause a short circuit, start a fire, or cause an explosion with personal injury or property damage.

CAUTION: For your safety you must carefully read this manual and follow its instructions. Your bicycle may come with additional instruction sheets that cover features unique to your bike. Please ensure that you read and become familiar with their contents and retain them with this manual for future reference. Remember bicycles, in most areas, are subject to the same laws, rules, and regulations as motor vehicles.

Always wear a CPSC approved helmet when riding your bike.

Learn and follow local and state traffic use laws.

Any major service or adjustments on your bike not covered in this manual should be carried out by a professional bicycle mechanic. If you wish to make adjustments yourself, this manual contains important tips on how to do it.

CAUTION: Any adjustments you make are entirely at your own risk. Do **NOT** use your bike for freestyle and stunt riding, jumping or competitive events. Even if you are riding a mountain bike, you should know that off-road use or any similar activities can be dangerous, and you assume the risk for personal injury, damages or losses incurred from such use. Do not ride your bike when any part is damaged or not working properly.

You must, for your safety and the safety of other users, consult a professional bicycle mechanic for any questions on repairs or maintenance.

WARNING

As with all mechanical components, the bicycle is subjected to wear and high stresses. Different materials and components react to wear or stress fatigue in different ways. As your bicycle ages, you should inspect it more frequently to look for deformed, cracked, bent, or loose components. Such conditions may lead to sudden failure. This may possibly cause injuries to the rider. If something is cracked or broken, do not ride until repairs have been made.

ALWAYS WEAR A HELMET! IT COULD SAVE YOUR LIFE

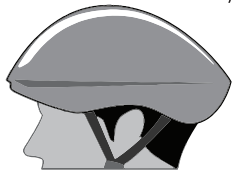

A properly fitting, CPSC-approved bicycle helmet should be worn at all times when riding your e-bike.

- The correct helmet should:
- be lightweight and comfortable
 - have good ventilation
 - cover the forehead and fit correctly
 - be securely fastened on the rider

Parts Description

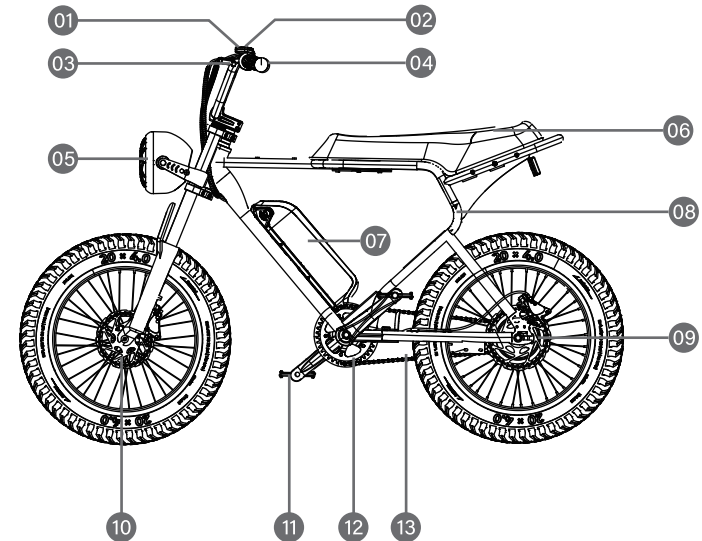

- | | |
|---------------------------------|---------------------|
| 01 Monitor Display | 08 Frame |
| 02 Throttle (Not Shown) | 09 Motor |
| 03 Brake handlebar | 10 Front disc brake |
| 04 Headlight switch (Not Shown) | 11 Pedal |
| 05 Headlight | 12 Controller |
| 06 Cushion | 13 Chain |
| 07 Battery | |

Assembly Instructions

Your new bicycle was assembled and tuned in the factory and then partially disassembled for shipping. The following instructions will enable you to prepare your bicycle for years of enjoyable cycling. For more details on inspection, lubrication, maintenance and adjustment of any area please refer to the relevant sections in this manual.

If you have questions about your ability to properly assemble this bicycle, please consult a professional bicycle mechanic before riding.

WARNING

TO AVOID INJURY, THIS PRODUCT MUST BE PROPERLY ASSEMBLED BEFORE USE. WE STRONGLY RECOMMEND THAT YOU REVIEW THE COMPLETE ASSEMBLY GUIDE AND PERFORM CHECKS SPECIFIED IN THE OWNER'S MANUAL BEFORE RIDING.

Preparation

It is important that you read this owner's manual before you start to assemble your bicycle.

WE HIGHLY RECOMMEND THAT YOU CONSULT A PROFESSIONAL BICYCLE MECHANIC IF YOU HAVE DOUBTS OR CONCERNS AS TO YOUR ABILITY TO PROPERLY ASSEMBLE, REPAIR, OR MAINTAIN YOUR E-BIKE.

Remove all parts from the shipping carton. Check to make sure no parts are loose on the bottom of the carton. Carefully remove the front wheel which is attached to the side of the bicycle for shipping. Carefully remove all other packing material from the bicycle. This includes zip ties, axle caps and material protecting the frame.

Front Wheel Installation

- Align the front disc at the space of the gateway lining, align the front axle at the front fork axle hole and insert it into the hole.
- Install gaskets and cap nuts on both sides.
- Tighten the capped nuts on both sides using a hex wrench.

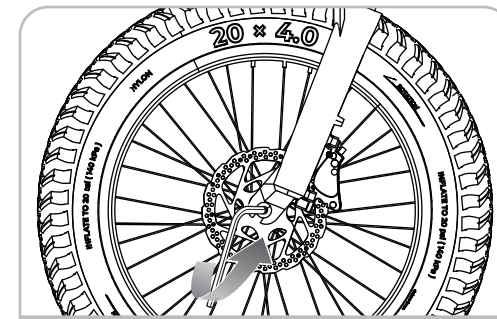
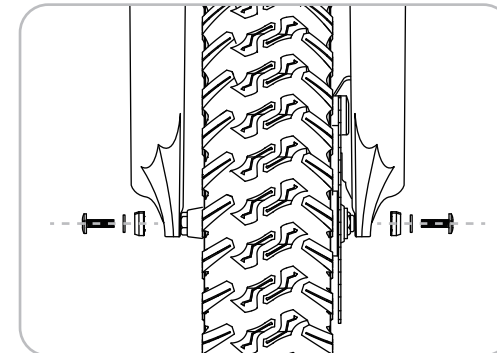
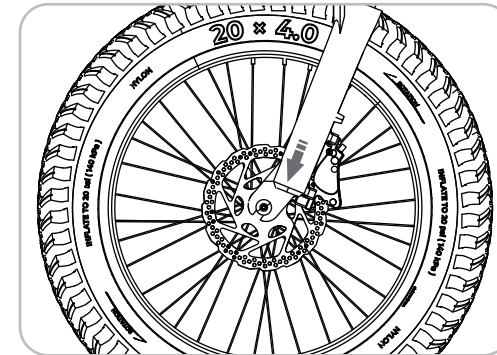

The locking force is 25-30N.m

Handlebar Installation

Remove the pre-tightened set screws of the handlebar end cover using 6mm socket head wrench.

Place the handlebar, adjust it to a suitable angle, close the end cover of the handlebar and pre-tighten 4 screws using 6mm socket head wrench.

Tighten set screws of the handlebar end cover in the order of 1, 4, 2 and 3 (24-27N.m).

Note: After tightening the screw, make sure that the gap width between the uprights is consistent.

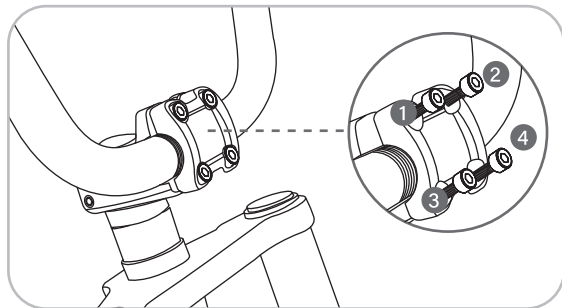
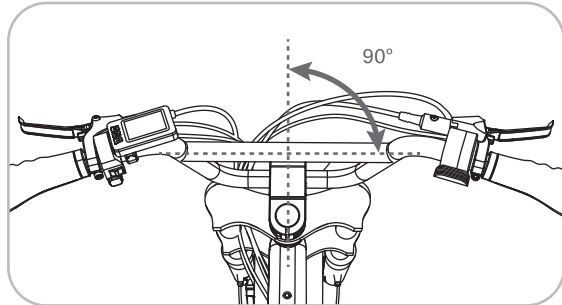
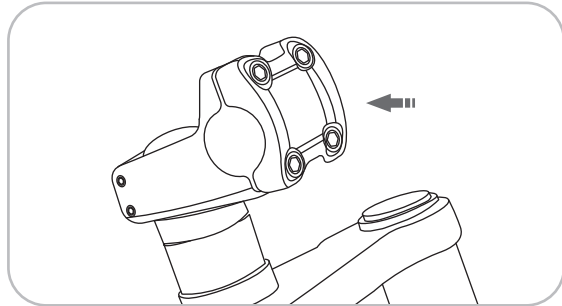

Check that the forks and the handlebars are facing forward and straight. Stand at the front of the handlebar, view the front wheel by your legs and hold the handlebar, adjust the handlebar and the body of the bicycle to form a 90° angle, see the diagram above.

Pedal Installation

- Differentiate the identifiers of left and right pedals, L means left pedal and R means right pedal.
- When installing pedals, keep the pedal bolt end face vertical to the mounting hole of the crank and tighten and fix it using 15mm open spanner. (When installing the left pedal, rotate it anticlockwise; when installing the right pedal, rotate it clockwise).

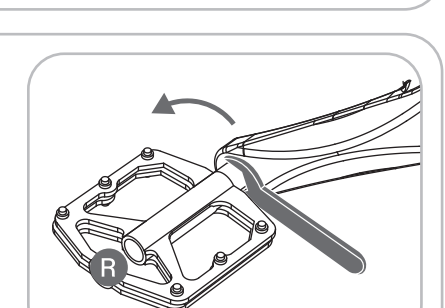
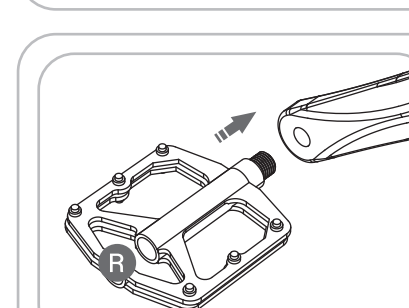
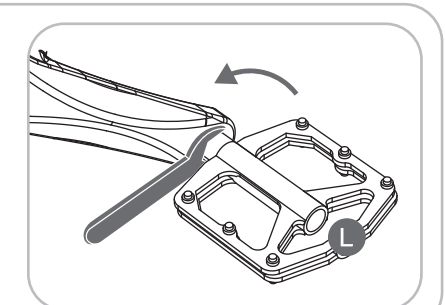
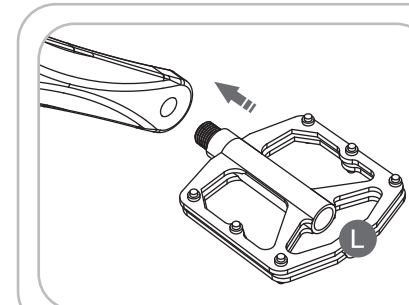
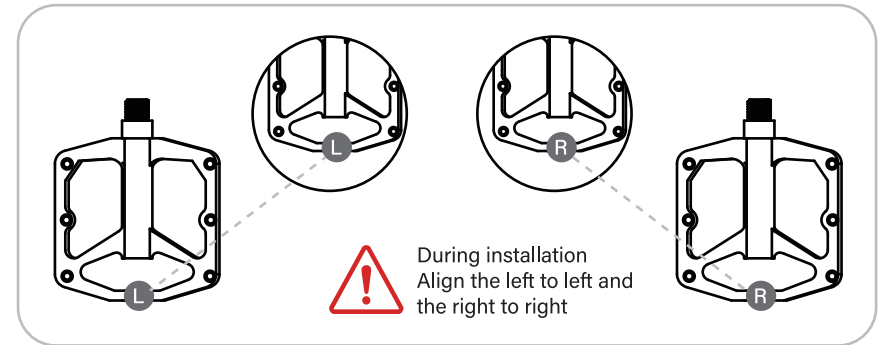

Headlamp installation

- Take the headlamp accessories out of the accessory box and install the fixed support of the headlamp;
- Adjust the headlamp angle and tighten set screws of the supports on both sides using 5mm socket head wrench;
- Connect the connecting line of the headlamp.

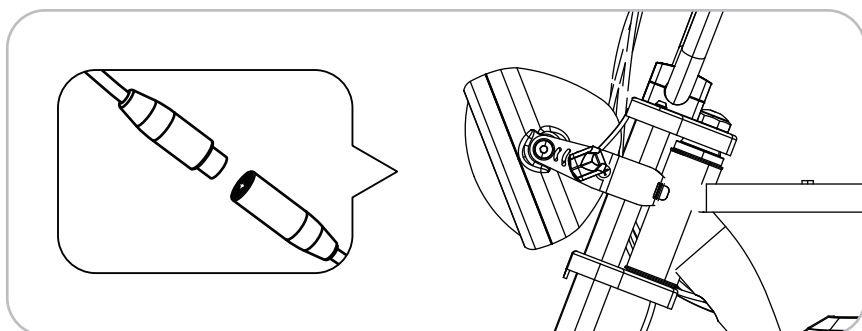
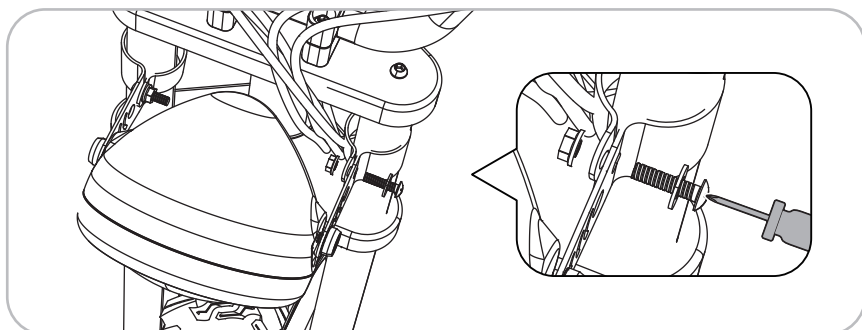
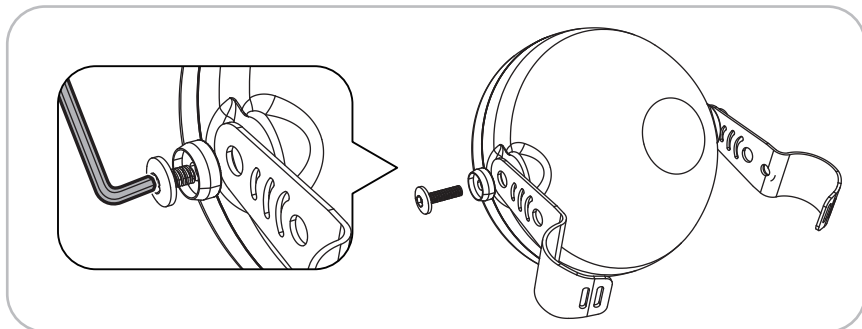

Battery Installation and Removal

Your e-bikes battery pack is removable. It is recommended you remove your battery pack if you are not riding your e-bike for extended periods of time, storing it, or have parked your e-bike in an unsecure location.

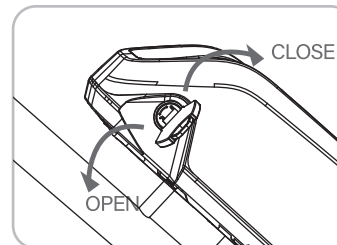

UNLOCK BATTERY

Insert your e-bike key into the keyhole and turn counterclockwise to unlock battery.

LOCKING THE BATTERY

Align and attach your battery, insert your e-bike key into the keyhole and turn clockwise to lock your battery to the frame.

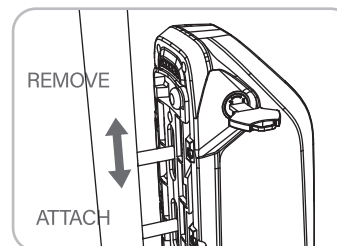

DETACHING / REATTACHING YOUR BATTERY

After unlocking your battery pack, slide the full battery pack upwards to remove from the frame.

To reattach, ensure the key has been turned into the "unlock" position, align your battery pack to your e-bike frame, and slide down to lock into the frame. Turn your key to the "lock" position and remove your key.

Battery disposal

WARNING: Do not dispose of the battery in a fire or with household waste. Contact your local waste disposal agency for the address of the nearest battery deposit site.

No, rechargeable batteries of any kind should not be placed in your trash can (or dumpster). It is illegal in some states to do so because rechargeable batteries contain heavy metals that can be hazardous to the environment.

WARNING

- Recharge battery after every use.
- Do not disassemble or alter the battery/charger.
- Do not place battery/charger near open flame or corrosive substances.
- Do not allow any liquids on or inside the battery/charger.
- Do not expose the battery/charger to extreme weather conditions.
- Do not operate the battery/charger if damaged.
- Recharge the battery only with a charger specified by the manufacturer.
- Only use the battery/charger in its intended purpose.
- Only use the battery/charger on approved products.

Battery Charging

Before charging your e-bike battery, ensure that your battery pack is turned off. Flip the Power Switch on your battery pack to the "O" position to turn it off.

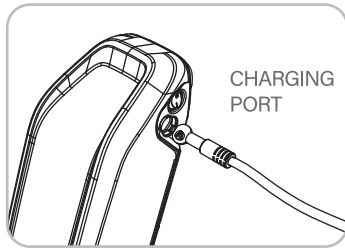

- Open the soft cover on the battery side.
- Insert the plug of the charger into the charging port of the battery and connect the other plug to the power supply.
- The status light of the charger is red in the charging process.
- After the battery is fully charged, the status light of the charger is green.

Battery Care & Maintenance

1. Please charge the battery after its energy is consumed for 50% - 70% of its total energy, rather than waiting until the battery's energy is fully consumed. Doing so ensures you extend your battery's lifespan. Charge the battery pack to full after each long-distance ride. Do not charge the battery for a long time (in excess of 10 hours) in summer. Doing so may damage the battery.

2. Recharge the battery once a month, even if your e-bike is in storage and not being used.

3. The ideal charging temperature is between 32°F - 104°F (0°C - 40°C).

4. Battery pack might not be fully charged when temperature is over low or over high.

When the battery is charged, its temperature may become a little higher, it is normal under the temperature of 50°C. If the charger indicator is useless when the battery is full charged or the battery is very hot (that exceeds 50°C), please come to the seller to find maintenance at once.

5. Do not jolt the charger in the rear box if there is one box attached; and the charger should be far away from water. The impact and shake should be at the lowest degree when the battery is moved.

6. Each specially designed charger is provided for each battery pack. Do not use other type of charger for fear of burning out battery and causing danger.

7. Battery storage conditions: cleanliness, coolness, dryness and airiness, temperature 0°C - 45°C. Keep away from long-term sun-exposure, fire, water-logging and mixing the battery together with corrosive substance during battery shipping and storage.

8. Please let the key on the head of the battery case be "on" when you charge it.

9. Please sure that there is no short-circuit in your wall socket for fear of burning out battery and causing danger.

10. Please don't pull out the power key when you are riding the bike forward under high speed.

Riding Introduction

1.1 Before Riding

• Stand in front of the bicycle facing rearward and hold the front wheel securely between your legs. Try to twist the handlebar and verify that they do not move. Then pull the handlebars up, trying to lift the bike. There should be no movement.

• Try to push the front wheel from side to side and confirm that it feels tight and will not wobble. Lift the front wheel up by the handlebars and strike the wheel downward with the heel of your hand to confirm that it is securely attached to the wheel. Spin the front wheel and confirm that it does not wobble or contact the fork or brake pads.

• Try to lift/push down on and twist the seat to confirm it is tight.

• Look at the connection of the pedals to the crank arm. You should not see pedal screw threads and the pedal should feel firm and be parallel to the ground.

• Apply your brake(s) and make sure they feel firm to the touch, and then spin the wheel(s). Apply the brakes. The brakes should stop the wheel(s).

• Check to be sure that the fenders and accessories (if equipped) are firmly attached and will not contact any moving parts. Make sure all reflectors are in position and not broken.

Now, put on your BICYCLE SAFETY HELMET and enjoy your ride. Your safety is well worth just a minute. Also, be sure to read and follow the warnings and instructions in this manual.

1.2 Riding modes

Fully charge the battery and make sure the battery switch is on before riding. Start your E-Bike by pressing and holding the power button for 2s.

Speed Modes	Assisted Bike
0	×
ECO-MID-HIGH	√
Display OFF	×

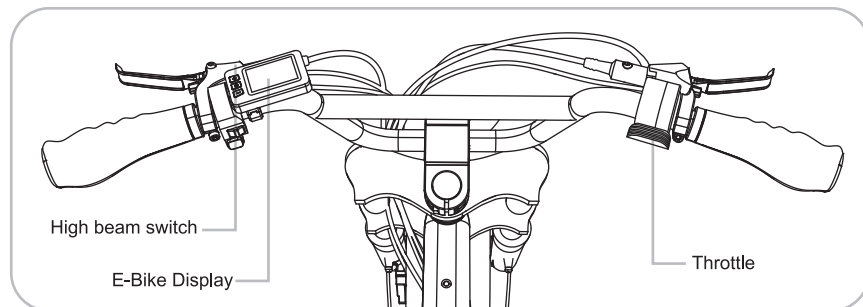

In pure electric mode:

The electric bicycle starts in gear '0' by default, and you can accelerate by gently pressing the throttle.

In electric bicycle assist mode:

You can switch between assist levels 1-3 by pressing the **+** and **-** buttons.

Automatic follow function, speed: 6km/h

Press and hold **-** to move forward, release to stop.

About lights

Headlight

- 1.The headlight turn on by default when the bike turns on.
- 2.Turn off: Turn off the bike or turn off the battery.

High Beam

Press the high beam switch to turn on or off the high beam.

1.3 Monitor display

Display information

- Battery level: This icon indicates the battery remainder.
- Speed mode: This icon indicates the current speed level.
- Speed display: This icon indicates the current speed in km/h.
- Total mileage: This icon indicates the total mileage in km.

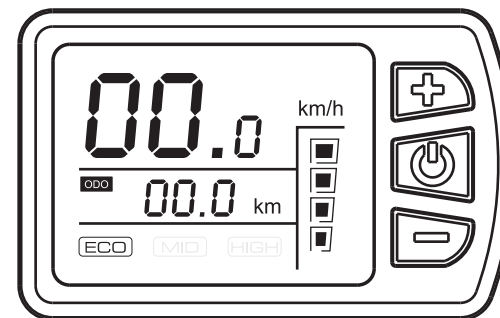

Button information

- Quick-press to switch from speed modes HIGH-MID-ECO.
- Press and hold for ~2 seconds to turn the E-Bike on/off.
- Quick-press to switch from speed modes ECO-MID-HIGH.

SPECIFICATIONS

Model No	EL-M20S
Product Dimensions	1629*686*1030 MM
Material	Steel
Brakes	Single mechanical disc brake
Type of Battery	Removeable + Li-ion 18650 48V 10.4Ah
Motor	48V 500W
Max. Torque	50 N.m
Speed Modes	0-3 Lever
Max. Speed	40 KM/25 MPH
Max. load	100 KG/220 LBS
Sensor	Double hall 12 pulse Speed Sensor
Tire	20*4.0 INCH
Charge Time	4-6 HOURS
Water Resistance	IPX4
Storage Temperature	20°C-25°C / 68°F-77°F
Operating Temperature	-4°F-140°F /-20°C~60°C

E-Bike Inspection Checklist

Before every ride, it is important to carry out the following safety checks on a regular basis:

BRAKES:

- Ensure front and rear brakes work properly
- Ensure brake shoe pads are not over worn and are correctly positioned in relation to the rims.
- Ensure brake control cables are lubricated correctly, adjusted and display no obvious wear.
- Ensure brake levers are lubricated and tightly secured to the handlebar.

WHEELS & TIRES:

- Ensure tires are inflated to within the recommended limit as displayed on the tire sidewall.

SAFETY WARNING

There is a danger of wheel failure due to rim wear.
Replace wheel immediately when/if any part of the above groove wears off.

- Ensure tires have tread and have no bulges or excessive wear.
- Ensure rims run true and have no obvious wobbles or kinks.
- Ensure all wheel spokes tight and not broken.
- Check that axle nuts are tight. If your bicycle is fitted with quick release axles, make sure locking levers are correctly tension and in the closed position.

STEERING COLUMN:

- Ensure handlebar and stem are correctly adjusted and tightened, and allow proper steering.
- Ensure that the handlebars are set correctly in relation to the forks and the direction of travel.
- Check that the headset locking mechanism is properly adjusted and tightened.
- If the bicycle is fitted with handlebar end extensions. Ensure they are properly positioned and tightened.

FRAME & FORK:

- Check that the frame and fork are not bent or broken.
- If either are bent or broken, they should be replaced.

CHAIN:

- Ensure chain is oiled, clean and runs smoothly.
- Please go to the qualified technician for adjusting the correct chain tension.
- Extra care is required in wet or dusty conditions.

REAR SUSPENSION:

- Please check the rear suspension connection regularly.

BEARINGS:

- Ensure all bearings are lubricated, run freely and display no excess movement, grinding, or rattling.
- Check headset, wheel bearing, pedal bearings and bottom bracket bearings.

CRANKS & PEDALS:

- Ensure pedals are securely tightened to the cranks.
- Ensure cranks are securely tightened to the axle and are not bent.

DERAILLEURS:

- Check that front rear mechanisms are adjusted and function properly.
- Ensure control levers are securely attached.
- Ensure derailleurs, shift levers and control cables are properly lubricated.

ACCESSORIES:

- Ensure that all reflectors are properly fitted and not obscured.
- Ensure all other fittings on the bike are properly and securely fastened, and functioning.
- Ensure the rider is wearing a helmet.

WARNING

If any safety-critical components need to be changed,
please see an authorized retailer or professional bicycle
repair shop.

CAUTION!

This assembly and operation manual shall remain an integral part of the e-bike. When you transfer the e-bike to others, please include this manual as it contains the important safety guidance and operation instructions. Anyone riding the e-bike should carefully read the safety guidance and operation instructions prior to riding.

Changes in pictures, diagrams, data, descriptions and specifications in this manual may change as we continuously improve our products.

WARRANTY

- Your E-Bike includes a One-Year Limited Hardware Warranty. The Warranty covers product defects in materials and labor costs under normal use.
- E-Bike offers a warranty of Frame for 12 months. As per any problem regarding manufacturing process and material defects, which includes product breakages during the riding (except riding improperly).
- E-Bike offers 12 months Battery and Motor Warranty. But this warranty does not cover the faulty operation or failure to properly follow the manufacturer's User Manual.
- All other parts except consumable parts are guaranteed for 12 months for problems caused by the manufacturing process or material defects. For instance: brake blocks, brake pads, brake handles, tires, and brake tubes are consumable parts.

NOTE:

Consumables are not included in the after-sale. The consumables including inner tubes, outer tires, etc are not guaranteed. The following situations are not quality issues and do not apply to this warranty.

- 1: Failure caused by not following the User Manual.
- 2: Normal wear and tear, accident, abuse, neglect of care, improper assembly, or incorrect parts maintenance, and incorrect use of accessories by any user.
- 3: It is a part that will naturally wear out under normal use, or does not apply to the aforementioned warranty policy.
- 4: Failure to perform proper replacement and maintenance due to wear and tear of consumables, causing other parts to malfunction and damage.
- 5: The warranty card does not match or alter the model of the bike.
- 6: Damage caused by overloading, riding over obstacles (including but not limited to descending steps, falling, etc.), performing extreme sports, etc.
- 7: Damage caused by force majeure (such as fire, earthquake, lightning, water damage, etc.).
- 8: Covered by the warranty policy but exceeding the warranty date.