



Propane Construction Heater

USER'S INSTALLATION, OPERATION AND MAINTENANCE MANUAL MODELS:

RMC-LPC25DG/DGD/DGP/DGP-01 & LPC25	(PROPANE, 25,000 BTU/hr)
RMC-LPC80DG/DGD/DGP/DGP-01	(PROPANE, 80,000 BTU/hr)
RMC-LPC80C/L/L-01	(PROPANE, 80,000 BTU/hr)
RMC-LPC200L/DG/DGP/DGP-01	(PROPANE, 200,000 BTU/hr)



C US

ANS Z83.7-2017 CSA 2.14-2017
CONSTRUCTION HEATER

 Adequate ventilation must be provided.



GHP Group, Inc.
6440 W Howard St
Niles, IL 60714-3302

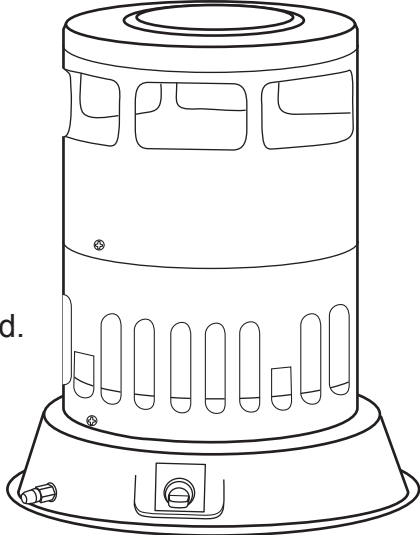

 **GENERAL HAZARD WARNING:**

Failure to comply with the precautions and instructions provided with this heater, can result in death, serious bodily injury and property loss or damage from hazards of fire, explosion, burn, asphyxiation, carbon monoxide poisoning and/or electrical shock.

Only persons who can understand and follow the instructions should use or service this heater.

If you need assistance or heater information such as an instruction manual, labels, etc., contact the manufacturer.

 **WARNING**

This product and the fuels used to operate this product (liquid propane), and the products of combustion of such fuels, can expose you to chemicals including benzene, which is known to the State of California to cause cancer and reproductive harm.

For more information go to www.p65Warnings.ca.gov

Questions, problems, missing parts? Before returning to your retailer, call our customer service department at 877-447-4768 8:30 a.m. – 4:30 pm CST, Monday – Friday or email us at customerservice@ghpgroupinc.com
www.ghpgroupinc.com

CONSUMER: RETAIN THIS MANUAL FOR FUTURE REFERENCE.

Warranty

LIMITED WARRANTY:

This limited warranty is extended to the original retail purchaser of this Forced Air/Convection/Radiant Heater and warrants against any defect in materials and workmanship for a period of one (1) year from the date of retail sale (lifetime warranty for the brass nozzle burner only). GHP Group, Inc., at its option, will either provide replacement parts or replace or repair the unit, when properly returned to the retailer where purchased or one of our service centers as directed by GHP Group, Inc., within one (1) year of retail purchase. (Shipping costs, labour costs, etc. are the responsibility of the purchaser.)

DUTIES OF THE OWNER:

This heating appliance must be operated in accordance with the written instructions furnished with this heater. This warranty shall not excuse the owner from properly maintaining this heater in accordance with the written instructions furnished with this heater. A bill of sale, canceled check or payment record must be kept to verify purchase date and establish warranty period. Original carton should be kept in case of warranty return of unit.

WHAT IS NOT COVERED:

1. Damage resulting from use of improper fuel.
2. Damage caused by misuse or use contrary to the owners manual and safety guidelines.
3. Damage caused by a lack of normal maintenance.
4. Fuses
5. Use of non-standard parts or accessories.
6. Damage caused in transit. Freight charges on warranty parts or heaters to and from the factory shall be the responsibility of the owner.

This warranty does not imply or assume any responsibility for consequential damages that may result from the use, misuse, or the lack of routine maintenance of this heating appliance. A cleaning fee and the cost of parts may be charged for appliance failures resulting from lack of maintenance. This warranty does not cover claims which do not involve defective workmanship or materials. **FAILURE TO PERFORM**

GENERAL MAINTENANCE (INCLUDING CLEANING) WILL VOID THIS WARRANTY.

THIS LIMITED WARRANTY IS GIVEN TO THE PURCHASER IN LIEU OF ALL OTHER WARRANTIES, EXPRESSED OR IMPLIED, INCLUDING BUT NOT LIMITED TO THE WARRANTIES OF MERCHANTABILITY OF FITNESS FOR A PARTICULAR PURPOSE. THE REMEDY PROVIDED IN THIS WARRANTY IS EXCLUSIVE AND IS GRANTED IN LIEU OF ALL OTHER REMEDIES. IN NO EVENT WILL GHP GROUP, INC. BE LIABLE FOR INCIDENTAL OR CONSEQUENTIAL DAMAGES.

Some states do not allow limitations on how long an implied warranty lasts, so the above limitation may not apply to you. Some states do not allow the exclusion or limitation of incidental or consequential damages so the above limitation or exclusion may not apply to you.

CLAIMS HANDLED AS FOLLOWS:

1. Contact your retailer and explain the problem.
2. If the retailer is unable to resolve the problem, contact our Customer Service Dept. detailing the heater model, the problem, and proof of date of purchase.
3. A representative will contact you. DO NOT RETURN THE HEATER TO GHP GROUP, INC. unless instructed by our Representative. This warranty gives you specific legal rights and you may also have other rights which vary from state to state.

TO REGISTER THE WARRANTY ON YOUR HEATER, PLEASE FILL OUT THIS CARD COMPLETELY
AND MAIL WITHIN 14 DAYS FROM DATE OF PURCHASE OR REGISTER ON-LINE AT www.ghpgroupinc.com

NAME: _____ PHONE: () _____ EMAIL: _____
ADDRESS: _____ CITY: _____ STATE: _____ ZIP: _____
MODEL: _____ SERIAL #: _____ DATE PURCHASED: _____
DEALER PURCHASED FROM: _____ TYPE OF STORE: _____
CITY & STATE WHERE PURCHASED: _____ PRICE PAID: _____

Please Take a Minute To Give Us Your Answers To The Following Questions.

All Responses Are Used Solely For Market Research And Are Held In Strict Confidence.

Who primarily decided this purchase? Male Female 18-24 25-39 40-59 60 and over

Purpose of Purchase? _____

Do you own any other portable heaters? Yes No If yes, type _____ brand _____

How do you intend to use your new heater? Construction Site Farm Warehouse/Commercial Garage/Outbuilding Other

How did you become aware of this heater? In-Store Display Newspaper Ad Magazine Ad Friend/Relative

TV Commercial Store Salesperson Other _____

What made you select this heater? Style Size/Portability Price Package Brand Other _____

Do you: own rent Would you recommend this heater to a friend? Yes No

Please give us your comments: _____

THANK YOU FOR COMPLETING THIS FORM!

Information will be held confidential.

Table of Contents

Specifications 2

Safety Information 3

Theory of Operation..... 6

Ventilation 6

Assembly 7

Operation..... 8

 Lighting/Operating Instructions RMC-LPC25Series / RMC-LPC80 Series..... 8

 Lighting/Operating Instructions RMC-LPC200 Series..... 9

Troubleshooting 9

Maintenance 10

Replacement Parts 10

 Replacement Parts Illustration RMC-LPC25 Series..... 11

 Replacement Parts List..... 11

 Replacement Parts Illustration RMC-LPC80 Series..... 12

 Replacement Parts List..... 12

 Replacement Parts Illustration RMC-LPC200 Series..... 13

 Replacement Parts List..... 13

Warranty 14

IMPORTANT: Read and understand this manual before assembling, starting or servicing heater. Improper use of heater can cause serious injury. Keep this manual for future reference.

 **WARNING:** Using this heater in a residential garage requires that the heater is positioned so that it is protected against any possible damage by a moving vehicle, etc. It must be positioned so that the base of the heater is no less than 18 in (450 mm) above the garage floor or 8 ft (2450 mm) in repair garages. The heater must be placed on a stable surface. Do not place it on a chair, ladder, etc. Raising the heater will reduce BUT NOT eliminate the possibility of lighting the vapor of any flammable liquids which may be improperly stored or accidentally spilled. If the smell of gasoline is present, DO NOT operate this heater until the area has been properly ventilated.

 **WARNING: CONSTRUCTION HEATERS ARE NOT FOR USE IN GARAGES IN CANADA.**

 **WARNING: Fire, burn, inhalation and explosion hazard. Keep solid combustibles, such as building materials, paper or cardboard, a safe distance away from the heater as recommended by the instructions. Never use the heater in spaces which do or may contain volatile or airborne combustibles or products such as gasoline, solvents, paint thinner, dust particles or unknown chemicals.**

 **WARNING: Not for home or recreational vehicle use.**

Specifications

Convection Heater

Fuel Type.....	Propane Vapor Only
Ignition Type	LPC25/LPC80/LPC200Piezo
Minimum Operating Temperature	-20°F (-29°C) Surrounding Air

Important Safety Information

For either indoor or outdoor use. Adequate ventilation shall be provided in accordance with OSHA 29 CFR 1926.154, Safety Requirements for Temporary and Portable Space Heating Devices and Equipment ANSI A10.10, ANSI 223.1 / NFPA 54, Liquefied Petroleum Gas Code, NFPA 58 or the National Gas and Propane Installation Code, CAN B149.1 as appropriate.

WARNING Air Quality Hazard

- Do not use this heater for heating human living quarters.
- Use of direct-fired heaters in the construction environment can result in exposure to levels of CO, CO₂, and NO₂ considered to be hazardous to health and potentially life threatening.
- Do not use in unventilated areas
- Know the signs of CO and CO₂ poisoning
 - Headaches, stinging eyes
 - Dizziness, disorientation
 - Difficulty breathing, feels of being suffocated
- Proper ventilation air exchange (OSHA 29 CFR 1926.57) to support combustion and maintain acceptable air quality shall be provided in accordance with OSHA 29 CFR Part 1926.154, ANSI A10.10 Safety Requirements for Temporary and Portable Space Heating Devices and Equipment used in the Construction Industry or the Natural Gas and Propane Installation Codes CSA B149.1
 - Periodically monitor levels of CO, CO₂ and NO₂ existing at the construction site – at the minimum at the start of the shift and after 4 hours.
 - Provide ventilation air exchange, either natural or mechanical, as required to maintain acceptable indoor air quality

USA 8-Hr Time weighted average
(OSHA 29 CFR 1926.55 App A)

Canada 8-hr time weighted average
WorkSafe BC OHS Guidelines Part 5.1
and Ontario Workplaces Reg 833

CO 50 ppm

25 ppm

CO₂ 5000 ppm

5000 ppm

NO₂

3 ppm (Reg 833)

USA – Ceiling Limit
(Short Term Exposure Limit = 15 minutes)

Canada STEL (15 minutes Reg 833/1 hour
WSBC) WorkSafe BC OHS Guidelines Part
5.1 and Ontario Workplaces Reg 833

CO

100 ppm

CO₂

15000 ppm (WSBC)
30000 ppm (Reg 833)

NO₂ 5 ppm

1.0 ppm (WorkSafeBC)
5.0 ppm (Reg 833)

- Ensure that the flow of combustion and ventilation air exchange cannot become obstructed.
- As the building ‘tightens up’ during the construction phases ventilation may need to be increased.

Important Safety Information

- Children should be carefully supervised, when they are in the area.
- Always maintain proper clearance from combustible materials. Minimum clearance from combustibles: Side - 24" (61 cm); Top- 60" (152.4 cm); Front - 72" (183 cm). Floor - combustible. Not for use on finished floors.
- Heater must be placed on level and stable surface.
- Never place anything including clothes or other flammable items on the heater.
- The appliance area shall be kept clear and free from combustible materials, gasoline and other flammable vapours and liquids.
- Do not modify or operate a heater which has been modified.
- Adequate clearance for accessibility and for combustion & ventilation air supply must be maintained at all times when the heater is operating.
- Service and repair should be done by a qualified service person. The heater should be inspected before each use and at least annually by a qualified person. More frequent cleaning may be required as necessary. Do not service while hot or operating.
- Never connect heater to an unregulated gas supply.
- The heater is shipped from the factory for LP(Propane) gas. This heater is for use with propane gas only, do not convert heater to any other gas. Installation must conform to local codes or, in the absence of local codes, with the standard for the Storage and Handling of Liquefied Petroleum Gases ANSI/NFPA 58 and the Natural Gas and Propane Installation Code CSA B149.1
- The minimum and maximum inlet pressures to the regulator from the gas tank are 5 psi and bottle pressure, respectively. Use only the regulator & hose assembly provided with the heater. Inspect the regulator/hose assembly prior to each use of the heater. If there is excessive abrasion or wear, or hose is cut, replace with regulator/hose assembly listed on the parts list prior to using this heater.
- Gas supply connections should be checked using a 50/50 solution of liquid dish soap and never use a flame to check for gas leaks.
- The electrical connection & grounding must comply with National Electrical Code. ANSI/NFPA 70 or in Canada CSA C22.1, Canadian Electrical Code, Part 1. Use only a properly grounded three (3) prong receptacle.
- Do not restrict inlet or outlet by any means. The flow of combustion and ventilation air is not to be obstructed.
- This heater should not be directed toward any propane-gas container within 20 ft (6M). The heater must be located at least 6 ft. (1.83 m) in the U.S.; or (ii) 10 ft. (3 m) in Canada, from any propane gas container.
- The propane cylinder supply system must be arranged to provide for vapour withdrawal from the operating cylinder.
- This heater is not to be used with external thermostats, timers or other devices that control or alter electrical supply to the heater.
- Heater must be placed on a flat stable surface. Do not position the heater at any other angle than the intended design position. Certain models can change the up and down tilt angle by loosening the "height control screw" and moving the "height controller", then retightening the "height control screw".
- This heater is not designed to thaw ground surfaces.
- Installation of this Appliance at altitudes above 2000 ft. (610 m) shall be in accordance with local codes, or in the absence of local codes the, National Fuel Gas Code, ANSI Z223.1 / NFPA 54, or National Standard of Canada, Natural Gas and Propane Installation Code, CSA B149.1.

Specifications

Model #	Rating (BTU/hr.)		Fuel Consumption (lb/h)		Supply Pressure		Manifold Pressure	Ignitor Gap (Inch)	Size (Inch)
	High	Low	Minimum	Maximum	Maximum	Minimum			
LPC25 Series	25,000	15,000	0.7 (0.32 kg/h)	1.16 (0.53 kg/h)	Bottle pressure	5psi	11.0" w.c.	.196 (4.98 mm)	11.7 x 12.87 (29.69 x 32.79 cm)
LPC80 Series	80,000	50,000	2.32 (1.05 kg/h)	3.71 (1.68 kg/h)	Bottle pressure	5psi	11.0" w.c.	.196 (4.98 mm)	15.9 x 18.3 (40.41 x 46.99 cm)
LPC200 Series	200,000	50,000	2.32 (1.05 kg/h)	9.28 (4.21 kg/h)	Bottle pressure	12psi	10psi	.196 (4.98 mm)	15.9 x 26.2 (40.41 x 66.49 cm)

Safety Information

The heater is designed for use as a construction heater in accordance with ANSI Z83.7, CSA 2.14. Other standards govern the use of fuel gases and heating products for specific uses. Your local authority can advise you about these. The primary purpose of construction heaters is to provide temporary heating of building under construction, alteration or repair. Properly used, the heater provides safe economical heating. Products of combustion are vented into the area being heated.

We cannot foresee every use which may be made of our heaters. **CHECK WITH YOUR LOCAL FIRE SAFETY AUTHORITY IF YOU HAVE QUESTIONS ABOUT HEATER USE.**

Other standards govern the use of fuel gases and heat producing products for specific uses. Your local authorities can advise you about these.

Carbon monoxide poisoning: Some people are more affected by carbon monoxide than others. Early signs of carbon monoxide poisoning resemble the flu, with headaches, dizziness and/or nausea. If you have these signs, the heater may not be working properly. **Get fresh air at once!** Check for proper ventilation and have heater serviced.

Propane gas: Propane gas is odorless. An odor-making agent is added to propane gas. The odor helps you detect a propane gas leak. However, the odor added to propane gas may fade. Propane gas may be present even though no odor exists.

Make certain you read and understand all Warnings. Keep this manual for reference. It is your guide to safe and proper operation of this heater.

- Install and use heater with care. Follow all local ordinances and codes. In the absence of local ordinances and codes refer to the Standard for Storage and Handling of Liquefied Petroleum Gas, ANSI/NFPA 58 and the Natural Gas Installation Code, CSA B149.1. This instructs on the safe storage and handling of propane gas.
- Use only propane gas set up for vapor withdrawal.
- Provide adequate ventilation. Before using heater, provide at least a six-square-foot opening of fresh, outside air. This heater produces carbon monoxide, which is listed by the State of California as a reproductive toxin under Proposition 65.
- For indoor or outdoor use.

- Do not use heater in occupied dwellings or in living or sleeping quarters.
- Do not use heater in a basement or below ground level. Propane gas is heavier than air. If a leak occurs, propane gas may sink to the lowest possible level.
- Keep appliance area clear and free from combustible materials, gasoline, paint thinner and other flammable vapors and liquids. Dust is combustible. Do not use heater in areas with high dust content.
- The heater must be located at least 6 ft. (1.83 m) in the U.S.; or (ii) 10 ft. (3 m) in Canada, from any propane gas container.

CLEARANCE TO COMBUSTIBLES:

MODEL	RMC-LPC25	RMC-LPC80	RMC-LPC200
Sides	2 ft. (60 cm)	2 ft. (60 cm)	3 ft. (91 cm)
Top	4 ft. (1.22 m)	5 ft. (1.52 m)	6 ft. (1.82 m)

- Keep propane tank(s) below 100°F (37.8 °C).
- Check heater for damage before each use. Do not use a damaged heater.
- Use only the hose and factory preset regulator provided with the heater.
- Check hose before each use of heater. If highly worn or cut, replace with hose specified by manufacturer before using heater.
- Do not alter heater. Keep heater in its original state.
- Do not use heater if altered.
- Locate heater on stable and level surface if heater is hot or operating.
- Not intended for use on finished floors.
- Never block air inlet (bottom of shell) or air outlet (around top of shell) of heater.
- Do not leave heater unattended.
- Keep children and animals away from heater.
- Never move, handle or service a hot or operating heater. Severe burns may result. Wait 15 minutes after turning heater off.
- To prevent injury, wear gloves when handling heater.
- Turn off propane supply to heater when not in use.
- Use only original replacement parts. This heater must use design-specific parts. Do not substitute or use generic parts. Improper replacement parts could cause serious or fatal injuries.

NEVER LEAVE THE HEATER UNATTENDED WHILE BURNING!

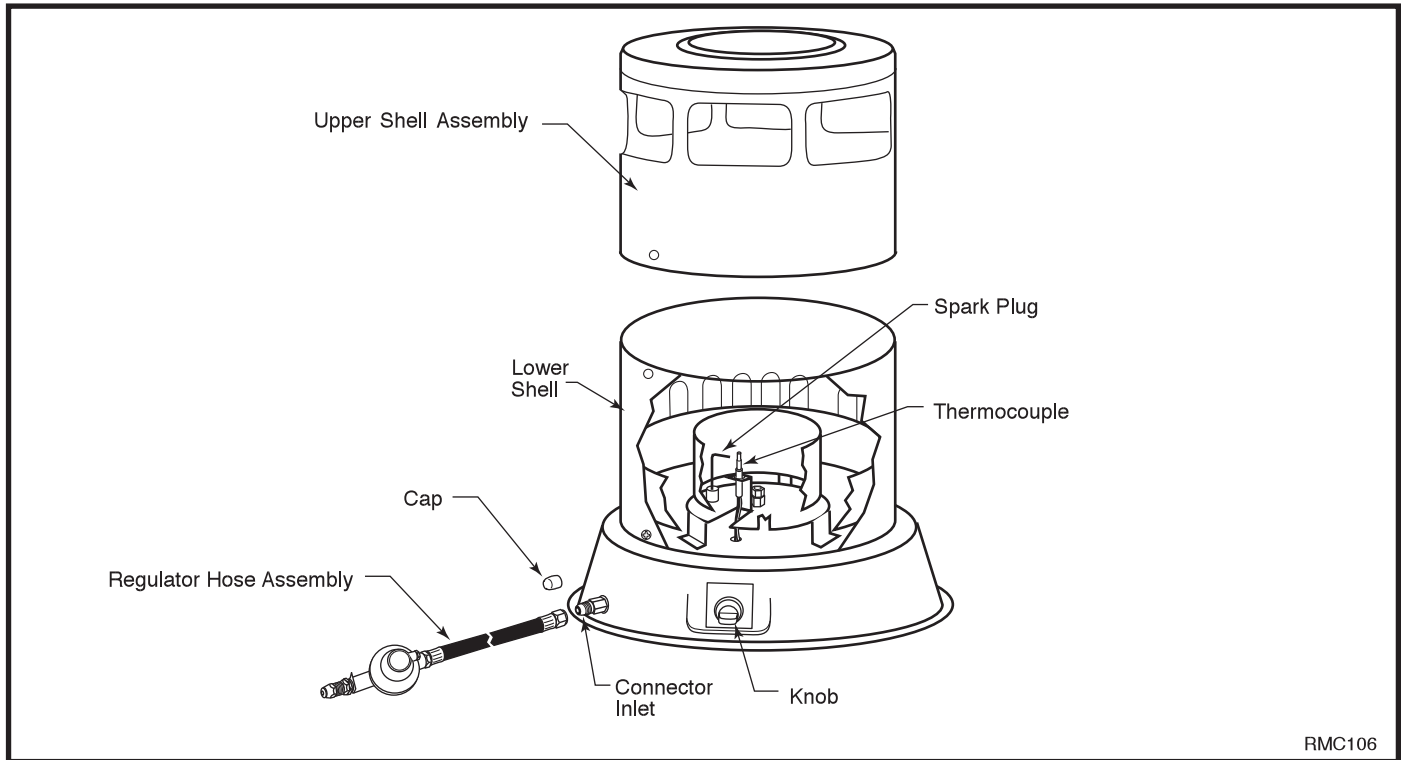

Fig. 1 Convection Heater parts identification.

Theory of Operation

The Fuel System: The hose/regulator assembly attaches to the propane gas supply. This provides fuel to the heater.

The Ignition System: The piezo ignitor lights the burner fuel supply on the LPC25/80. The piezo ignites a pilot burner on the LPC200.

The Automatic Control System: The automatic control valve shuts off the heater if the flame goes out.

Propane Supply

You must provide propane gas and tank(s).

Use this heater only with a propane vapor withdrawal supply system. Installation must conform to local codes or, in the absence of local codes, with the standard for the Storage and Handling of Liquefied Petroleum Gases ANSI/NFPA 58 and the Natural Gas and Propane Installation Code CSA B149.1. Your local library or fire department will have this booklet.

The amount of propane gas ready for use from propane tanks varies. Two factors decide this amount:

1. The amount of liquid propane gas in tank(s).
2. The temperature of tank(s).

The chart below shows the minimum number of 100-pound tanks or one larger tank may be needed in colder weather. Your local propane gas dealer will help you select the proper supply system.

Average Temp (°F) at Tank Location	Number of Tanks (100 lb.)		
	LPC25	LPC80	LPC200
60 °F (15.56 °C)	1	1	2
40 °F (4.44 °C)	1	1	2
32 °F (0 °C)	1	1	2
20 °F (-6.67 °C)	1	1	2
10 °F (-12.22 °C)	1	2	3
0 °F (-17.78 °C)	1	2	3

Ventilation

RMC-LPC25/80

WARNING: Provide at least a 2½ square feet (.23 square meters) opening of fresh, outside air while running heater. If proper fresh, outside air ventilation is not provided, carbon monoxide poisoning can occur. Provide proper fresh, outside air ventilation before running heater.

RMC-LPC200

WARNING: Provide at least a 6 square feet (.56 square meters) opening of fresh, outside air while running heater. If proper fresh, outside air ventilation is not provided, carbon monoxide poisoning can occur. Provide proper fresh, outside air ventilation before running heater.

Fresh Outside Air Opening Requirements

Heater Size	Opening
80,000 BTU/hr	2.5 ft² (.23 m²)
200,000 BTU/hr	6 ft² (.56 m²)

Assembly

Assembly Time: 10 minutes

Contents

All Models: Unit, Manual, Hose and Regulator Assembly

LPC80 and 200 Series Include:

Upper Shell, Lower Shell and Hardware Kit With Screws (8)

Tools Required for Assembly

All Models: Adjustable Wrench

LPC80 and LPC200 Series: Phillips head screwdriver

Heater Assembly

1. Remove all packing items applied to heater for shipment. Keep plastic cover caps (attached to connector inlet and regulator hose assembly) for storage.
2. Remove all items from carton and check for shipping damage. If heater is damaged, promptly inform dealer where you purchased the heater.



CAUTION: Do not attempt to light heater until fully assembled.

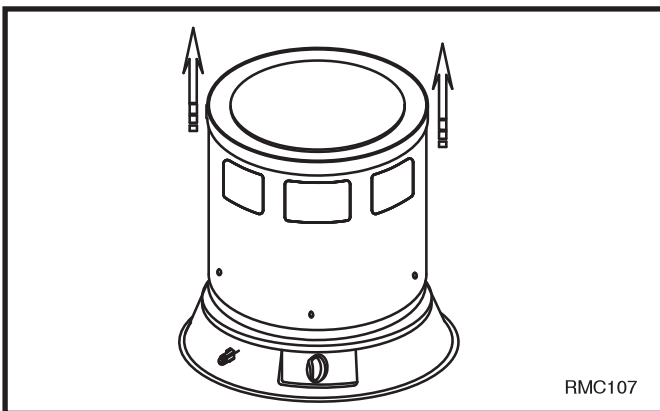

Fig. 2 Slide upper shell assembly up and off lower shell.

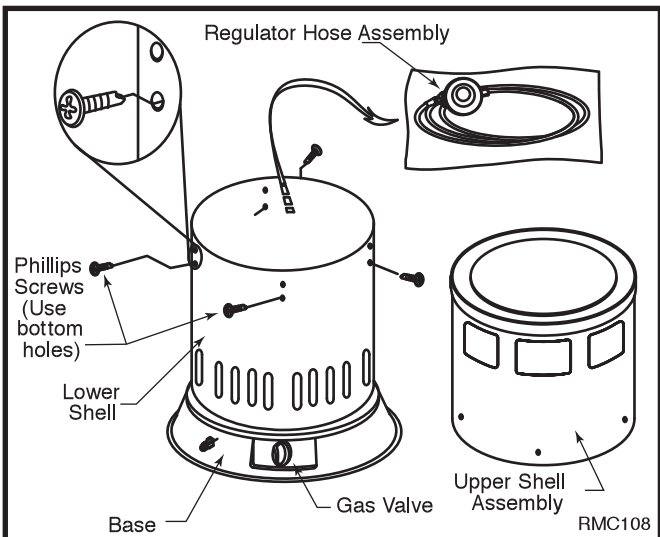

Fig. 3 Remove regulator hose assembly, place four screws in bottom holes at top of lower shell.

3. Slide upper shell assembly up and off lower shell. LPC80/200 (Fig. 2)
4. Remove regulator hose assembly bag from inside base.
5. Screw four phillips head screws in place in bottom hole at top of lower shell. LPC80/200 (Fig. 3)
6. Place upper shell assembly onto shell lower. Secure with four phillips screws in top hole of lower shell. (Fig. 4)

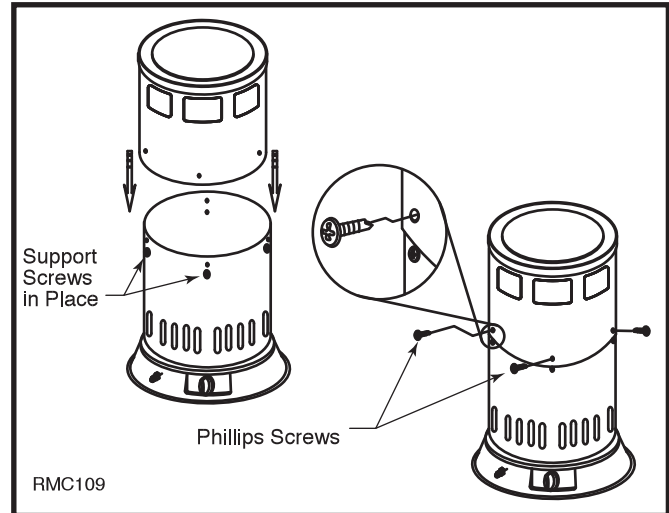

Fig. 4 Attach top with four phillips screws.

7. Provide propane supply system. (Refer to Propane Supply on Page 3)
8. Connect fuel gas fittings on regulator hose assembly to propane tank(s). Turn fuel gas fitting counterclockwise into threads on tank. Tighten firmly using a wrench. **IMPORTANT:** Tighten regulator with vent pointing down. Pointing vent down protects regulator from weather damage. (Fig. 5)
9. Connect hose to the connector inlet. (Fig. 6) Use a wrench to prevent connector inlet on heater from turning as you tighten firmly using a wrench. You must use the regulator supplied with heater even if propane tank has one.

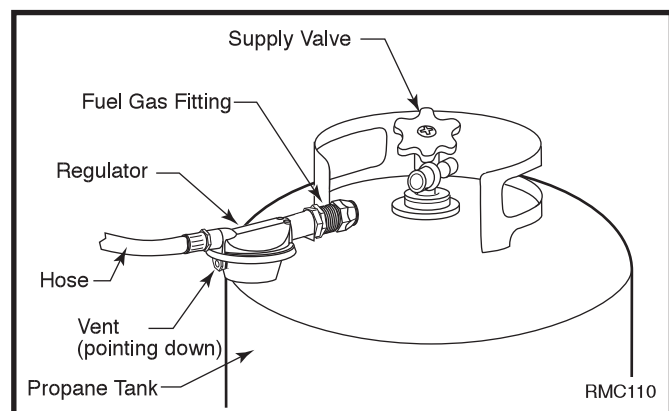

Fig. 5 Attach regulator with vent pointing down.

NEVER LEAVE THE HEATER UNATTENDED WHILE BURNING!

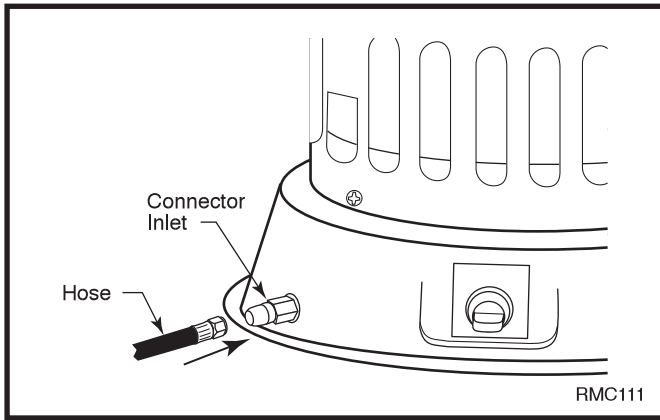

Fig. 6 Hose and connector inlet.

10. Open propane supply valve on propane tank(s) slowly. **NOTE:** If not opened slowly, excess-flow check valve on propane tank may stop gas flow. If this happens, you may hear a click inside the regulator assembly, this is the check valve closing. To reset the excess-flow check valve, close propane supply valve and open it again slowly.
11. Check all connections for leaks. Apply mixture of liquid soap and water to gas joints. Bubbles forming show a leak that must be corrected before using the heater.
Close propane supply valve.

Operation



WARNING: Review and understand the warnings in the Safety Information section on page 3. They are needed to safely operate this heater. Follow all local codes when using this heater.

Lighting/Operating Instructions RMC-LPC25/80

CAUTION







Due to high surface temperature, keep children, clothing and furniture away. Keep burner and control compartment clean. This heater shall not be installed in a bedroom or a bathroom.

WARNING





Hot while in operation: Do not touch. Keep children, clothing, furniture, gasoline and other liquids having flammable vapors away.

NOTE: On completing the gas line connection, a small amount of air will be trapped in the gas line. When you first light the unit with the pilot light, it is possible that it will take a few minutes to purge the trapped air. Once you have purged the gas line, the pilot and burner will light and operate normally. Subsequent lightings of the appliance will not require purging the gas line.

1. **Stop!** Read the safety information on side of heater.
2. Turn control knob clockwise  to "OFF" (○) position.
3. Turn propane supply valve on by turning tank valve counterclockwise .
4. Depress control knob and turn counterclockwise  to "LOW/IGN" position to light burner.
5. If burner does not light, turn knob to the "OFF" (○) position and repeat Step 4. Keep control knob depressed for approximately 10 to 15 seconds, release control knob.
6. If flame burner goes out, wait 5 minutes then repeat steps 4 and 5.
7. With burner operating, the control knob may be turned counterclockwise  to desired heating level between "LOW" and "HIGH."

To Turn Off Appliance

1. Turn control knob clockwise  to "OFF" ○ position.
2. Turn propane supply valve off by turning fully clockwise .

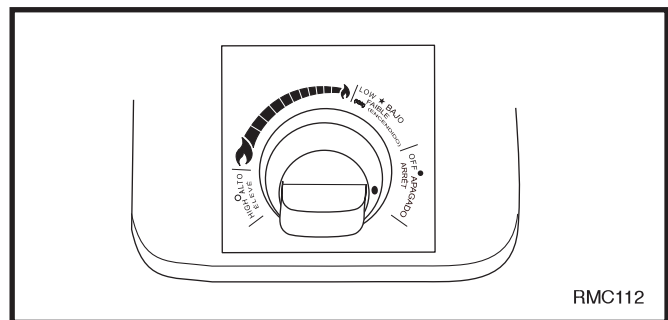

Fig. 7 Convection Heater control knob.

NEVER LEAVE THE HEATER UNATTENDED WHILE BURNING!

Lighting/Operating Instructions RMC-LPC200



WARNING: BEFORE LIGHTING PILOT, close main burner valve (by rotating the handle clockwise).

Start: Read Safety Information before starting the heater.

1. Fully open the valve on the propane cylinder counter clockwise  and wait 15 seconds before proceeding to step 2.
2. Depress the red button on safety pilot valve admitting gas to the pilot. Push and release the ignition button until the pilot lights.
3. When the pilot lights, continue to hold button depressed for the 30 seconds then release.
4. If pilot goes out, wait 5 minutes and repeat lighting procedure.

5. When the pilot remains lit, open main burner valve to operate heater. Partially close valve to regulate heat output.

STOP:

1. Securely close valve on the propane cylinder.
2. Close main burner valve.

RESTART AFTER SAFETY SHUTDOWN

1. Securely close valve at propane cylinder.
2. Wait 5 minutes.
3. Restart following "Start" procedure.

Troubleshooting

RMC-LPC25/80/200 Propane Convection Heater



WARNING: Never attempt to service heater while it is connected, operating or hot. Severe burns can occur.

Symptom	Possible Cause	Remedy
Burner fails to light	<ol style="list-style-type: none">1. Propane supply valve closed on propane tank(s).2. Excess-flow check valve closed.3. Blockage in burner nozzle.4. Piezo ignition system not sparking.	<ol style="list-style-type: none">1. Open propane supply valve slowly.2. Close propane supply valve on propane tank and reopen slowly.3. Replace burner nozzle.4. Check to assure ignitor electrode gap is .196" (4.98 mm). Check wire lead for damage.
Burner lights but goes out when automatic control valve button is released	<ol style="list-style-type: none">1. Not enough warm-up time.2. Low gas pressure.3. Thermocouple loose or needs to be replaced.4. Automatic control valve needs to be replaced.	<ol style="list-style-type: none">1. Relight, hold automatic control valve button in 45 seconds.2. Check propane tank(s) for proper gas supply.3. Tighten connection or replace thermocouple.4. Replace automatic control valve.
Burn rate is low	<ol style="list-style-type: none">1. Main burner valve not fully open.2. Plugged gas orifices.3. Low gas pressure.4. Low fuel supply.	<ol style="list-style-type: none">1. Fully open main burner valve by turning control knob towards HIGH position until it stops.2. Replace gas orifice.3. Check gas supply; check regulator output.4. Consult propane gas supplier.

Maintenance



WARNING: Never attempt to service heater while it is connected to propane supply, operating or hot. Severe burns can occur.

1. Keep heater clean.
2. Inspect heater before each use. Check connections for leaks. Apply mixture of liquid soap and water to connections. Bubbles forming show a leak that must be corrected. Correct all leaks at once.
3. Inspect regulator hose assembly before each use. If hose is highly worn or cut, replace with hose specified by manufacturer.
4. Have heater inspected yearly by a qualified service person.

Storage



CAUTION: Disconnect heater from propane supply tank(s).

1. Store propane tank(s) in safe manner. Refer to Chapter 5 of Standard for Storage and handling of Liquefied Petroleum Gases, ANSI/NFPA 58, and the Natural Gas and Propane Installation Code CSA B149.1. Follow all local codes. Always store propane tanks outdoors.
2. Place plastic cover caps over brass fittings on connector inlet and regulator hose assembly.
3. Store in a dry, clean and safe place.

Replacement Parts

Warning: Use only original replacement parts. This Heater must use design-specific parts. Do not substitute or use generic parts. Improper replacement parts could cause serious or fatal injuries.

This will also protect your warranty coverage for parts replaced under warranty.

Parts warranty and non-warranty: Contact authorized dealers of this product. If they can not supply original replacement part(s), either contact your nearest Parts Central or GHP Group Inc., Technical Service Department at 1-877-447-4768.

When calling GHP Group Inc., have ready:

- your name
- your address
- how heater was malfunctioning
- serial number of heater
- model number of heater
- replacement part number

NEVER LEAVE THE HEATER UNATTENDED WHILE BURNING!

Replacement Parts for RMC-LPC25 Series

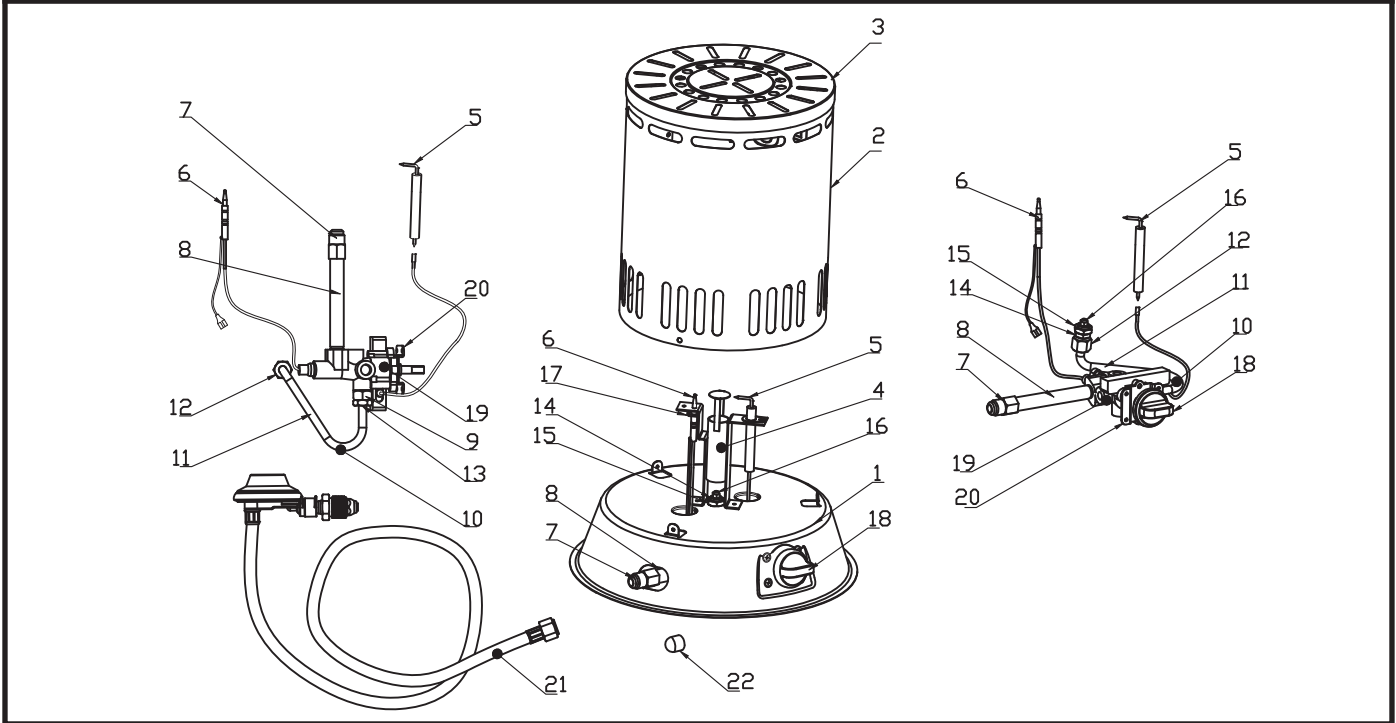

Replacement Parts List

GHP Group Inc., reserves the right to make changes in design, materials, specifications, prices and discontinue colors and products at any time, without notice.

Ref. No	Description	Quantity	RMC-LPC25
1.	Base	1	CFM25.00-01A
2.	Outer Shell	1	CFM25.01-01
3.	Cap	1	CFM25.01-02
4.	Burner Assy	1	CFM25.02
5.	Ignitor Electrode	1	CFM25.09-04B
6.	Thermocouple	1	1130/1396/210
7.	Inlet Fitting	1	CFM25.03
8.	Gas Inlet Tube	1	CFM25.04
9.	Elbow Fitting	1	CFM40.15
10.	Main Gas Tubing	1	CFM25.05
11.	Main Gas Tube	1	CFM25.05
12.	Lock Nut	1	CFM80.04-02
13.	Valve Nut	1	CFM80.04-03
14.	Nozzle Holder	1	CFM25.07
15.	Nozzle Fix Nut	1	CFM25.10
16.	Nozzle	1	CFM25.06
17.	Pilot Mounting	1	CFM40.07-01
18.	Knob	1	CFM80.00-10
19.	Valve Assy	1	GS22-LPC25
20.	Bracket	1	CFM80.03-01
21.	Regulator & Hose Assy 10' (3.05 m)	1	KR10601-10-31
	Regulator & Hose Assy 15' (4.57 m)	1	KR10601-15-31
22.	Inlet Cap	1	SPC-80VCB.006BZH
AVAILABLE PARTS NOT SHOWN			
23.	Screw	2	M4*7
24.	Screw-Tapping Screw	4	ST4.2*6.6
25.	Screw	7	ST4.2*9



WARNING: Use only original replacement parts. This heater must use design-specific parts. Do not substitute or use generic parts. Improper replacement parts could cause serious or fatal injuries. This will also protect your warranty coverage for parts replaced under warranty.

Replacement Parts for RMC-LPC80 Series

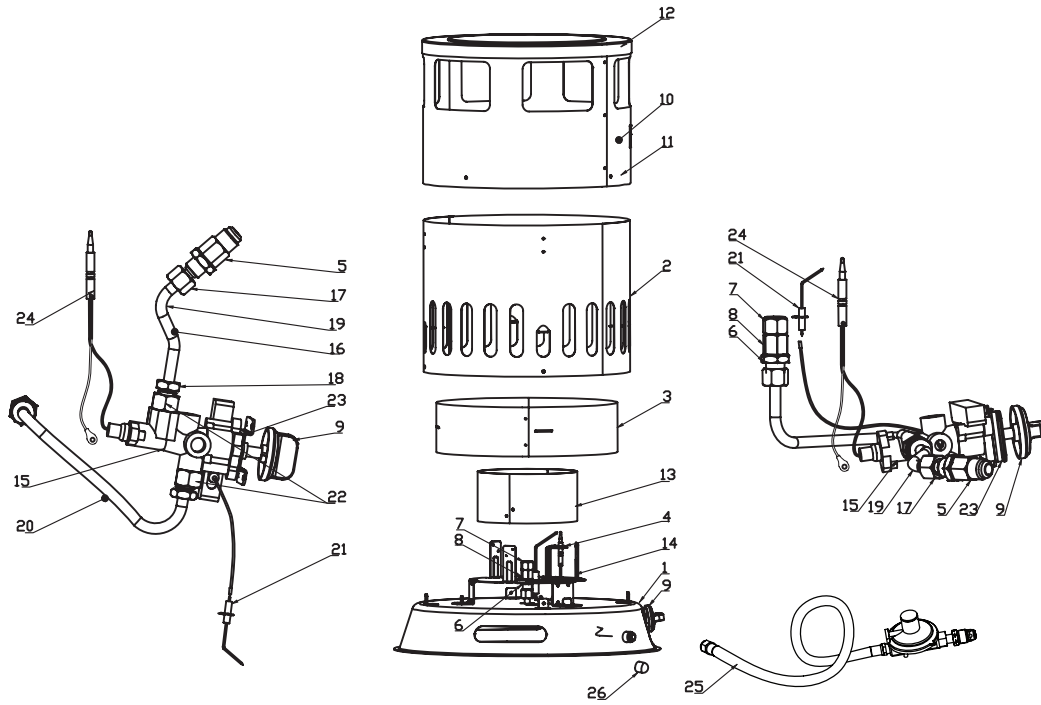

Replacement Parts List

GHP Group Inc., reserves the right to make changes in design, materials, specifications, prices and discontinue colors and products at any time, without notice.

Ref. No	Description	Quantity	RMC-LPC80
1.	Base	1	CFM80.00-01A
2.	Lower Shell	1	CFM80.00-02
3.	Inner Shell	1	CFM80.00-03
4.	Pilot Mounting	1	CFM80.00-05
5.	Inlet Fitting	1	CFM80.00-06
6.	Fix Nut	2	CFM80.00-07A
7.	Nozzle	1	CFM80.00-08
8.	Nozzle Holder	1	CFM80.00-09
9.	Knob	1	CFM80.00-010
10.	Upper Shell Assy	1	CFM80.01
11.	Upper Shell	1	CFM80.01-01
12.	Cap	1	CFM80.01-02
13.	Burner Ring	1	CFM80.02-02
14.	Burner Bracket	1	CFM80.02-01
15.	Valve Assy	1	GS22-LPC80
16.	Gas Inlet Tubing	1	CFM80.04
17.	Locked Nut	1	CFM80.04-02
18.	Valve Nut	1	CFM80.04-03
19.	Gas Inlet Tube	1	CFM80.04
20.	Main Gas Tubing	1	CFM80.05
21.	Ignitor Electrode	1	CFM80.06B
22.	Elbow Fitting	2	CFM40.15
23.	Bracket	1	CFM80.03-01
24.	Thermocouple	1	1130/1396-210
25.	Regulator & Hose Assy 10' (3.05 m)	1	GR109-10-31
	Regulator & Hose Assy 15' (4.57 m)	1	GR109-15-31
26.	Inlet cap	1	SPC-80VCB.006BZH
AVAILABLE PARTS NOT SHOWN			
27.	Screw	2	M4*7
28.	Self-Tapping Screw	4	ST4.2*6.6
29.	Screw	15	ST4.2*9



WARNING: Use only original replacement parts. This heater must use design-specific parts. Do not substitute or use generic parts. Improper replacement parts could cause serious or fatal injuries. This will also protect your warranty coverage for parts replaced under warranty.

NEVER LEAVE THE HEATER UNATTENDED WHILE BURNING!

Replacement Parts for RMC-LPC200 Series

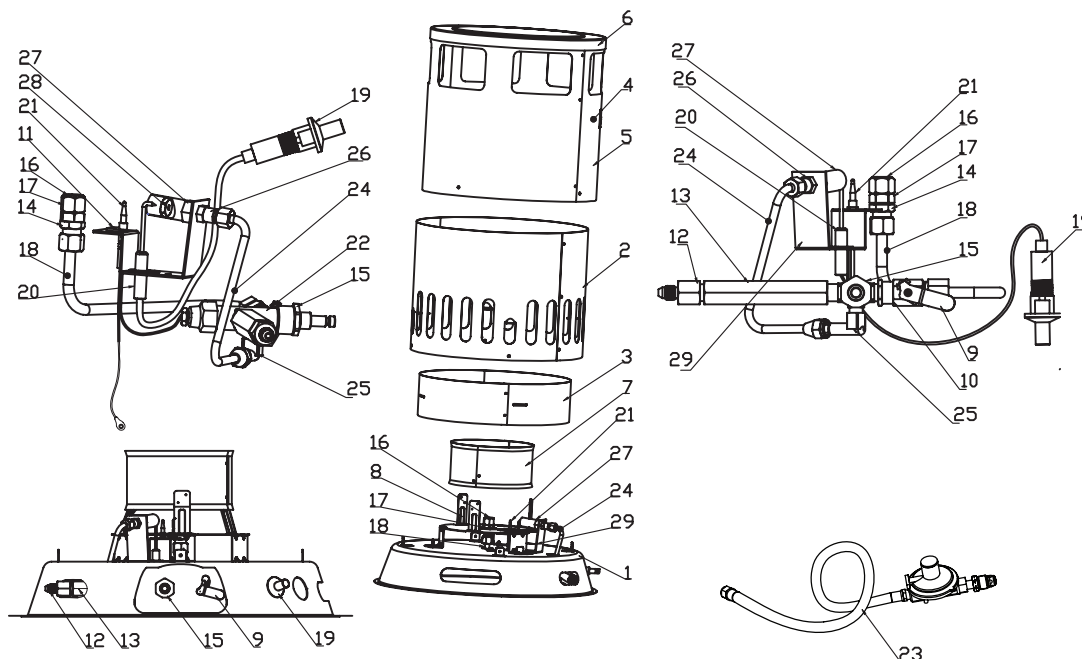

Replacement Parts List

GHP Group Inc., reserves the right to make changes in design, materials, specifications, prices and discontinue colors and products at any time, without notice.

Ref. No	Description	Quantity	RMC-LPC200
1.	Base	1	CFM200.00-01A
2.	Lower Shell	1	CFM200.00-03
3.	Inner Shell	1	CFM80.00-03
4.	Upper Shell Assy	1	CFM200.01
5.	Upper Shell	1	CFM200.01-01
6.	Cap	1	CFM80.01-02
7.	Burner Ring	1	SPC-80VCB.401
8.	Burner Bracket	1	CFM200.15-01
9.	Ball Valve Handle	1	CFM200.00-06
10.	Ball Valve Assy	1	GQ01
11.	Pilot Mounting	1	CFM80.00-05
12.	Inlet Fitting	1	CFM200.00-02
13.	Gas Inlet Tube	1	CFM200.00-010
14.	Fix Nut	1	CFM80.00-07
15.	Valve Fix Nut	1	SPC35.07-07B
16.	Nozzle	1	CFM200.00.04
17.	Nozzle Holder	1	CFM80.00-09
18.	Main Gas Tubing	1	CFM200.02
19.	Ignition Control	1	SPC694
20.	Ignitor Electrode	1	CFM200.14
21.	Thermocouple	1	1130/1496-210
22.	Control Valve	1	GS16
23.	Regulator & Hose Assy 10' (3.05 m)	1	GR108-10-25
	Regulator & Hose Assy 15' (4.57 m)	1	GR108-15-25
24.	Pilot Tubing	1	CFM200.10.00
25.	Elbow Fitting	1	SPC80VCB.105
26.	Pilot Nozzle	1	CFM200.11
27.	Pilot Tube	1	CFM200.12
28.	Pilot Burner Head	1	SPC-225VCB.132
29.	Pilot Mounting	1	CFM200.13
AVAILABLE PARTS NOT SHOWN			
30.	Screw	17	ST4.2*8



WARNING: Use only original replacement parts. This heater must use design-specific parts. Do not substitute or use generic parts. Improper replacement parts could cause serious or fatal injuries. This will also protect your warranty coverage for parts replaced under warranty.

WARRANTY REGISTRATION

IMPORTANT: We urge you to fill out your warranty registration card within fourteen (14) days of date of purchase. You can also register your warranty on the internet at www.ghpgroupinc.com. Complete the entire serial number. Retain this portion of the card for your records.



GHP Group, Inc.
6440 W Howard St
Niles, IL 60714-3302

Tel: (877) 447-4768
www.ghpgroupinc.com

SAVE THIS CARD!

Place
Postage
Stamp
Here

GHP Group, Inc.
6440 W Howard St
Niles, IL 60714-3302

