

OPERATOR'S MANUAL

INCLUDING: OPERATION, INSTALLATION & MAINTENANCE

PD05X-XXX-XXX-B

PE05X-XXX-XXX-B

1/2" DIAPHRAGM PUMP 1:1 RATIO (METALLIC)

RELEASED: 8-27-08
REVISED: 7-15-16
(REV: L)



**READ THIS MANUAL CAREFULLY BEFORE INSTALLING,
OPERATING OR SERVICING THIS EQUIPMENT.**

It is the responsibility of the employer to place this information in the hands of the operator. Keep for future reference.

SERVICE KITS

Refer to Model Description Chart to match the pump material options.

637427-XX for fluid section repair (see page 4).

637428 for air section repair (see pages 6 and 8).

PUMP DATA

Models	see Model Description Chart for "-XXX"
Pump Type	Metallic Air Operated Double Diaphragm
Material	see Model Description Chart
Weight ..	PX05A-XAS-XXX-B 10.36 lbs (4.70 kgs)
	PX05A-XSS-XXX-B 16.57 lbs (7.52 kgs)
	PX05R-XAS-XXX-B 8.04 lbs (3.65 kgs)
	PX05R-XSS-XXX-B 14.25 lbs (6.46 kgs)
Maximum Air Inlet Pressure	100 p.s.i.g. (6.9 bar)
Maximum Material Inlet Pressure	10 p.s.i.g. (0.69 bar)
Maximum Outlet Pressure	100 p.s.i.g. (6.9 bar)
Air Consumption @ 40 p.s.i.	1 c.f.m. / gallon (approx.)
Maximum Flow Rate (flooded inlet) ...	12.0 g.p.m. (45.4 l.p.m.)
Displacement / Cycle @ 100 p.s.i.g.	0.039 gal. (0.15 lit.)
Maximum Particle Size	3/32" dia. (2.4 mm)
Maximum Temperature Limits (diaphragm / ball / seat material)	
E.P.R. / EPDM	-60° to 280° F (-51° to 138° C)
Hytrel®	-20° to 180° F (-29° to 82° C)
Nitrile	10° to 180° F (-12° to 82° C)
Polypropylene	35° to 175° F (2° to 79° C)
Polyurethane	10° to 150° F (-12° to 66° C)
Santoprene®	-40° to 225° F (-40° to 107° C)
PTFE	40° to 225° F (4° to 107° C)
Viton®	-40° to 350° F (-40° to 177° C)
Dimensional Data	see pages 11 and 12
Noise Level @ 70 p.s.i., 60 c.p.m.	75.0 db(A)①

① The pump sound pressure levels published here have been updated to an Equivalent Continuous Sound Level (L_{Aeq}) to meet the intent of ANSI S1.13-1971, CAGI-PNEUROP S5.1 using four microphone locations.

NOTICE: All possible options are shown in the chart, however, certain combinations may not be recommended, consult a representative or the factory if you have questions concerning availability.

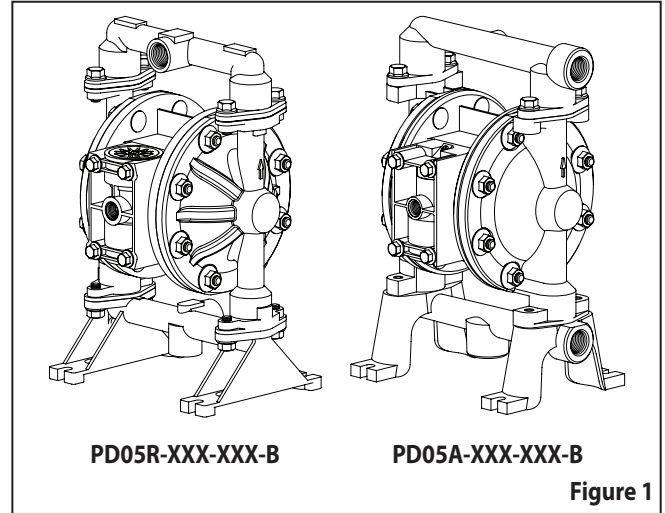

Figure 1

MODEL DESCRIPTION CHART

P X 05 X - X X S - X X X - B	
Electronic Interface D - None E - Available	
Center Section Material A - Aluminum R - Polypropylene	
Fluid Connection A - 1/2 - 14 N.P.T.F. - 1 B - Rp 1/2 (1/2 - 14 BSP parallel)	
Fluid Cap & Manifold Material A - Aluminum S - Stainless steel	
Hardware Material S - Stainless steel	
Seat Material F - Aluminum P - Polypropylene S - 316 Stainless steel	
Ball Material A - Santoprene T - PTFE C - Hytrel U - Polyurethane G - Nitrile V - Viton S - Stainless steel	
Diaphragm Material A - Santoprene T - PTFE / Santoprene C - Hytrel U - Polyurethane G - Nitrile V - Viton L - Long Life PTFE	
Fluid Section Service Kit Selection	
Example: Model #PD05A-AAS-SAA-B	
Fluid Section Service Kit # 637427-AA	
Ball <input checked="" type="checkbox"/> Diaphragm <input checked="" type="checkbox"/>	
637427 - <input checked="" type="checkbox"/> <input checked="" type="checkbox"/>	

OPERATING AND SAFETY PRECAUTIONS

READ, UNDERSTAND AND FOLLOW THIS INFORMATION TO AVOID INJURY AND PROPERTY DAMAGE.



WARNING EXCESSIVE AIR PRESSURE. Can cause personal injury, pump damage or property damage.

- Do not exceed the maximum inlet air pressure as stated on the pump model plate.
- Be sure material hoses and other components are able to withstand fluid pressures developed by this pump. Check all hoses for damage or wear. Be certain dispensing device is clean and in proper working condition.

WARNING STATIC SPARK. Can cause explosion resulting in severe injury or death. Ground pump and pumping system.

- Use the pump ground lug provided. Connect to a 12 ga. (minimum) wire (kit is included) to a good earth ground source.
- Sparks can ignite flammable material and vapors.
- The pumping system and object being sprayed must be grounded when it is pumping, flushing, recirculating or spraying flammable materials such as paints, solvents, lacquers, etc. or used in a location where surrounding atmosphere is conducive to spontaneous combustion. Ground the dispensing valve or device, containers, hoses and any object to which material is being pumped.
- Secure pump, connections and all contact points to avoid vibration and generation of contact or static spark.
- Consult local building codes and electrical codes for specific grounding requirements.
- After grounding, periodically verify continuity of electrical path to ground. Test with an ohmmeter from each component (e.g., hoses, pump, clamps, container, spray gun, etc.) to ground to insure continuity. Ohmmeter should show 0.1 ohms or less.
- Submerge the outlet hose end, dispensing valve or device in the material being dispensed if possible. (Avoid free streaming of material being dispensed.)
- Use hoses incorporating a static wire.
- Use proper ventilation.
- Keep inflammables away from heat, open flames and sparks.
- Keep containers closed when not in use.

WARNING Pump exhaust may contain contaminants. Can cause severe injury. Pipe exhaust away from work area and personnel.

- In the event of a diaphragm rupture, material can be forced out of the air exhaust muffler.
- Pipe the exhaust to a safe remote location when pumping hazardous or inflammable materials.
- Use a grounded 3/8" minimum i.d. hose between the pump and the muffler.

WARNING HAZARDOUS PRESSURE. Can result in serious injury or property damage. Do not service or clean pump, hoses or dispensing valve while the system is pressurized.

- Disconnect air supply line and relieve pressure from the system by opening dispensing valve or device and / or carefully and slowly loosening and removing outlet hose or piping from pump.

WARNING HAZARDOUS MATERIALS. Can cause serious injury or property damage. Do not attempt to return a pump to the factory or service center that contains hazardous material. Safe handling practices must comply with local and national laws and safety code requirements.

- Obtain Material Safety Data Sheets on all materials from the supplier for proper handling instructions.

WARNING EXPLOSION HAZARD. Models containing aluminum parts cannot be used with 1,1,1-trichloroethane, methylene chloride or other halogenated hydrocarbon solvents which may react and explode.

- Check pump motor section, fluid caps, manifolds and all wetted parts to assure compatibility before using with solvents of this type.

WARNING MISAPPLICATION HAZARD. Do not use models containing aluminum wetted parts with food products for human consumption. Plated parts can contain trace amounts of lead.

CAUTION Verify the chemical compatibility of the pump wetted parts and the substance being pumped, flushed or recirculated. Chemical compatibility may change with temperature and concentration of the chemical(s) within the substances being pumped, flushed or circulated. For specific fluid compatibility, consult the chemical manufacturer.

CAUTION Maximum temperatures are based on mechanical stress only. Certain chemicals will significantly reduce maximum safe operating temperature. Consult the chemical manufacturer for chemical compatibility and temperature limits. Refer to PUMP DATA on page 1 of this manual.

CAUTION Be certain all operators of this equipment have been trained for safe working practices, understand it's limitations, and wear safety goggles / equipment when required.

CAUTION Do not use the pump for the structural support of the piping system. Be certain the system components are properly supported to prevent stress on the pump parts.

- Suction and discharge connections should be flexible connections (such as hose), not rigid piped, and should be compatible with the substance being pumped.

CAUTION Prevent unnecessary damage to the pump. Do not allow pump to operate when out of material for long periods of time.

- Disconnect air line from pump when system sits idle for long periods of time.

CAUTION Use only genuine ARO replacement parts to assure compatible pressure rating and longest service life.

NOTICE Install the pump in the vertical position. The pump may not prime properly if the balls do not check by gravity upon start-up.

NOTICE Re-torque all fasteners before operation. Creep of housing and gasket materials may cause fasteners to loosen. Re-torque all fasteners to insure against fluid or air leakage.

NOTICE Replacement warning labels are available upon request: "Static Spark" pn 93616-1, Diaphragm Rupture" pn 93122.

WARNING = Hazards or unsafe practices which could result in severe personal injury, death or substantial property damage.

CAUTION = Hazards or unsafe practices which could result in minor personal injury, product or property damage.

NOTICE = Important installation, operation or maintenance information.

GENERAL DESCRIPTION

The ARO diaphragm pump offers high volume delivery even at low air pressure and a broad range of material compatibility options are available. Refer to the model and option chart. ARO pumps feature stall resistant design, modular air motor / fluid sections.

Air operated double diaphragm pumps utilize a pressure differential in the air chambers to alternately create suction and a positive fluid pressure in the fluid chambers, ball checks insure a positive flow of fluid.

Pump cycling will begin as air pressure is applied and will continue to pump and keep up with the demand. It will build and maintain line pressure and will stop cycling once maximum line pressure is reached (dispensing device closed) and will resume pumping as needed.

AIR AND LUBE REQUIREMENTS

⚠ WARNING EXCESSIVE AIR PRESSURE. Can cause pump damage, personal injury or property damage.

- A filter capable of filtering out particles larger than 50 microns should be used on the air supply. There is no lubrication required other than the "O" ring lubricant which is applied during assembly or repair.
- If lubricated air is present, make sure that it is compatible with the "O" rings and seals in the air motor section of the pump.

OPERATING INSTRUCTIONS

- Always flush the pump with a solvent compatible with the material being pumped if the material being pumped is subject to "setting up" when not in use for a period of time.
- Disconnect the air supply from the pump if it is to be inactive for a few hours.
- The outlet material volume is governed not only by the air supply, but also by the material supply available at the inlet. The material supply tubing should not be too small or restrictive. Be sure not to use hose which might collapse.
- When the diaphragm pump is used in a forced-feed (flooded inlet) situation, it is recommended that a "check valve" be installed at the air inlet.
- Secure the diaphragm pump legs to a suitable surface to insure against damage by vibration.

MAINTENANCE

- Certain ARO "Smart Parts" are indicated which should be available for fast repair and reduction of down time.
- Provide a clean work surface to protect sensitive internal moving parts from contamination from dirt and foreign matter during service disassembly and reassembly.
- Keep good records of service activity and include the pump in preventive maintenance program.
- Service kits are available to service two separate diaphragm pump functions: 1. AIR SECTION, 2. FLUID SECTION. The Fluid Section is divided further to match typical part Material Options.
- Before disassembling, empty captured material in the outlet manifold by turning the pump upside down to drain material from the pump.

DIAPHRAGM PUMP SERVICE

GENERAL SERVICE NOTES:

- Inspect and replace old parts with new parts as necessary. Look for deep scratches on metallic surfaces, and nicks or cuts in "O" rings.
- Tools needed to complete disassembly and repair:
 - 7/8" wrench, 1/2" socket or wrench, 3/8" socket or wrench, 3/8" Allen wrench, 10 mm Allen wrench, T-10 Torx screwdriver, torque wrench (measuring inch pounds), "O" ring pick.

FLUID SECTION DISASSEMBLY

1. Remove (61) top manifold.
2. Remove (19) "O" rings, (21) seats, (12) washers (where applicable) and (22) balls.
3. Remove (60) bottom manifold.
4. Remove (19) "O" rings, (21) seats, (12) washers (where applicable) and (22) balls.
5. Remove (15) fluid caps.
6. Remove (14) bolt, (6) diaphragm washer, (7) or (7 / 8) diaphragms and (5) washer.
7. Remove (1) connecting rod from air motor.
8. Carefully remove remaining (14) bolt, (6) diaphragm washer, (7) or (7 / 8) diaphragms and (5) washer from (1) connecting rod. Do not mar surface of connecting rod.

FLUID SECTION REASSEMBLY

- Reassemble in reverse order.
- Lubricate (1) connecting rod with Lubriplate® or equivalent "O" ring lubricant.
- Connecting rod (1) should be installed using 96571 bullet, included in service kit.
- Install (5) washers with i.d. chamfer toward diaphragm.
- When replacing PTFE diaphragms, install the 93465 Santoprene diaphragm behind the PTFE diaphragm.

• Hytre®, Viton® are registered trademarks of the DuPont Company • Kynar® is a registered trademark of Arkema Inc. • ARO® is a registered trademark of Ingersoll-Rand Company • Santoprene® is a registered trademark of Monsanto Company, licensed to Advanced Elastomer Systems, L.P. • Loctite® and 242® are registered trademarks of Henkel Loctite Corporation • 572™ is a trademark of Henkel Loctite Corporation • Lubriplate® is a registered trademark of Lubriplate Division (Fiske Brothers Refining Company) •

PARTS LIST / PX05X-XXX-XXX-B FLUID SECTION

① 637427-XX Fluid section service kit includes: Balls (see Ball Option, refer to -XX in chart below), Diaphragms (see Diaphragm Option, refer to -XX in chart below) and item 19 (listed below) plus items 144, 174 and 94276 Lubriplate FML-2 grease (pages 6 and 8).

SEAT OPTIONS PX05X-XXX-XXX-B				BALL OPTIONS PX05X-XXX-XXX-B							
"21"				① "22" (3/4" diameter)							
-XXX	Seat	Qty	Mtl	-XXX	Ball	Qty	Mtl	-XXX	Ball	Qty	Mtl
-FXX	95727	(4)	[A]	-XAX	93100-E	(4)	[Sp]	-XTX	93100-4	(4)	[T]
-PXX	93098-10	(4)	[P]	-XCX	93100-C	(4)	[H]	-XUX	93100-8	(4)	[U]
-SXX	93409-1	(4)	[SS]	-XGX	93100-2	(4)	[B]	-XVX	93100-3	(4)	[V]
				-XSX	93410-1	(4)	[SS]				

DIAPHRAGM OPTIONS PX05X-XXX-XXX-B										
-XXX	① Service Kit -XX = (Ball) -XX = (Diaphragm)	① "7"			① "8"			① "19" (3/32" x 1-5/16" o.d.)		
		Diaphragm	Qty	Mtl	Diaphragm	Qty	Mtl	"O" Ring	Qty	Mtl
-XXA	637427-XA	93465	(2)	[Sp]	-----	---	---	93763	(4)	[E]
-XXC	637427-XC	93465-9	(2)	[H]	-----	---	---	Y325-122	(4)	[B]
-XXG	637427-XG	93582-2	(2)	[B]	-----	---	---	Y325-122	(4)	[B]
-XXL	637427-XL	93111-L	(2)	[L]	93465	(2)	[Sp]	93265	(4)	[T]
-XXT	637427-XT	93111	(2)	[T]	93465	(2)	[Sp]	93265	(4)	[T]
-XXU	637427-XU	93112	(2)	[U]	-----	---	---	93119	(4)	[U]
-XXV	637427-XV	93581-3	(2)	[V]	-----	---	---	Y327-122	(4)	[V]

MATERIAL CODE
[A] = Aluminum
[B] = Nitrile
[C] = Carbon Steel
[E] = E.P.R.
[GFN] = Glass filled Nylon
[L] = Long Life PTFE
[H] = Hytrel
[K] = Kynar PVDF
[P] = Polypropylene
[Sp] = Santoprene
[SS] = Stainless Steel
[T] = PTFE
[U] = Polyurethane
[V] = Viton

MANIFOLD / FLUID CAP MATERIAL OPTIONS PX05X-XXX-XXX-B										
Item	Description (size)	Qty	Aluminum				Stainless Steel			
			PX05X-AAS-XXX-B		PX05X-BAS-XXX-B		PX05X-ASS-XXX-B		PX05X-BSS-XXX-B	
			N.P.T.	BSP	N.P.T.	BSP				
			Part No.	Mtl	Part No.	Mtl	Part No.	Mtl	Part No.	Mtl
12	Washer	(4)	95092	[A]	95092	[A]	-----	---	-----	---
15	Fluid Cap	(2)	95064	[A]	95064	[A]	94624	[SS]	94624	[SS]
60	Inlet Manifold	(1)	95065	[A]	95065-2	[A]	94626	[SS]	94626-2	[SS]
61	Outlet Manifold	(1)	95066	[A]	95066-2	[A]	94625	[SS]	94625-2	[SS]
63	Pipe Plug (1/2 - 14 N.P.T. x 9/16")	(1)	Y17-13-S	[K]	-----	---	Y17-13-S	[K]	-----	---
	(R 1/2 [1/2 - 14 BSP taper])	(1)	-----	---	96764691	[K]	-----	---	96764691	[K]

COMMON PARTS										
Item	Description (size)	Qty	Part No.	Mtl	Item	Description (size)	Qty	Part No.	Mtl	
② 1	Connecting Rod	(1)	96379	[SS]	29	Hex Flange Nut (5/16" - 18)	(16)	93886	[SS]	
5	Diaphragm Washer	(2)	94645	[GFN]	43	Ground Strap (models PX05R-XXX-XXX-B only)(see page 9)	(1)	92956-1	[SS]	
② 6	Diaphragm Washer	(2)	94622	[SS]	57	Ground Kit Assembly (not shown)	(1)	66885-1	---	
14	Flange Bolt (5/16" - 18 x 3/4")	(2)	94628	[SS]	76	Pipe Plug (1/8 - 27 N.P.T. x 1/4")(models PE05X-XXX-XXX-B only)(see pages 7 and 9)	(1)	Y227-2-L	[C]	
26	Flange Bolt (5/16" - 18 x 3/4")	(8)	94628	[SS]						
27	Bolt (5/16" - 18 x 1-1/4") (PX05A-XXX-XXX-B)	(16)	Y84-502-T	[SS]						
	(PX05R-XXX-XXX-B)	(16)	93095	[SS]						

② "Smart Parts", keep these items on hand in addition to the service kits for fast repair and reduction of down time.

PARTS LIST / PX05X-XXX-XXX-B FLUID SECTION

COLOR CODE		
Material	Diaphragm Color	Ball Color
Hytrele	Cream	Black (+)
Nitrile	Black	Red (+)
Polyurethane	Clear	Red
Santoprene	Tan	Tan
PTFE	White	White
Viton	Yellow (-)	Yellow (-)
		(-) Dot

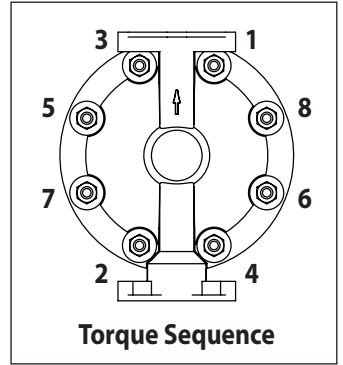

FOR THE AIR MOTOR SECTION, SEE PAGES 6 THRU 9.

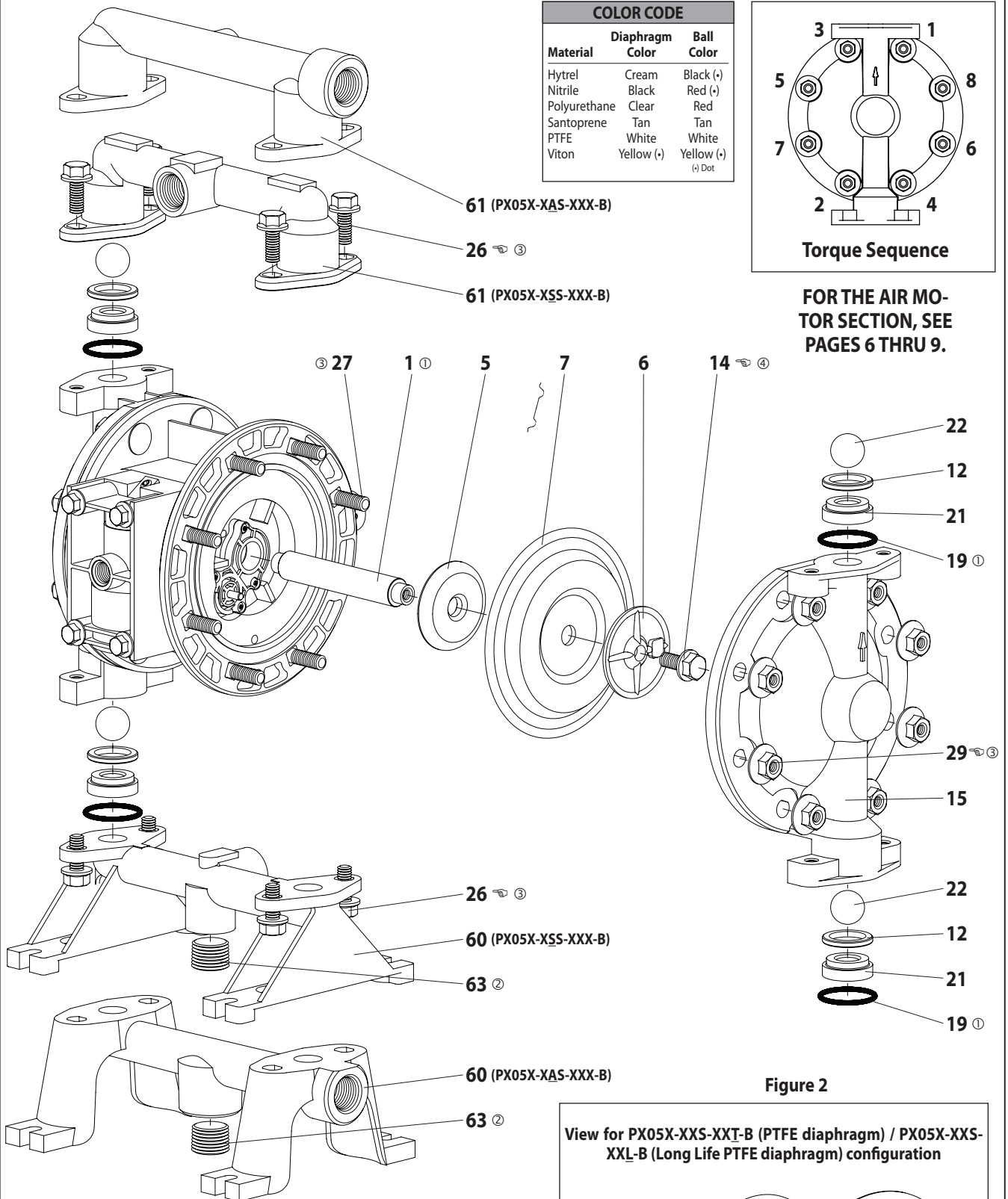
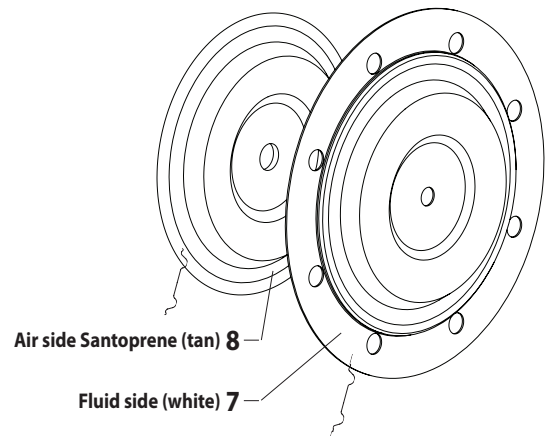

Figure 2

View for PX05X-XXS-XXI-B (PTFE diaphragm) / PX05X-XXS-XXL-B (Long Life PTFE diaphragm) configuration



ASSEMBLY TORQUE REQUIREMENTS

NOTE: DO NOT OVERTIGHTEN FASTENERS.

- (14) bolt, 95 - 105 in. lbs (10.7 - 11.9 Nm).
- (26) bolt and (29) nut, 50 - 60 in. lbs (5.6 - 6.8 Nm), alternately and evenly, then re-torque after initial run-in.

LUBRICATION / SEALANTS

- ① Apply Lubriplate FML-2 grease to all "O" rings, "U" cups and mating parts.
- ② Apply pipe sealant to threads.
- ③ Apply anti-seize compound to threads and bolt and nut flange heads which contact pump case when using stainless steel fasteners.
- ④ Apply Loctite® 242® to threads.

Note: Lubriplate FML-2 is a white food grade petroleum grease.

PARTS LIST / PX05A-XXX-XXX-B AIR MOTOR SECTION

⑤ Indicates parts included in 637428 air section service kit.

AIR MOTOR PARTS LIST

Item	Description (size)	Qty	Part No.	Mtl
101	Center Body	(1)	95978	[A]
103R	Cover (right side)	(1)	96091	[D]
103L	Cover (left side)	(1)	96351	[D]
111	Major Valve Spool	(1)	95919	[D]
118	Actuator Pin	(2)	97111	[SS]
⑤ 121	Washer	(2)	96092	[D]
123	Screw (#4 - 20 x 1/2")	(8)	96093	[SS]
129	Exhaust Cover	(1)	95979	[A]
130	Gasket	(1)	96632	[B]
⑤ 132	Air Manifold Gasket	(1)	96214-1	[B]
134	Flange Bolt (1/4" - 20 x 5-3/4")	(4)	94871	[SS]
135	Valve Block	(1)	95980	[Z]
136	Plug, Large (PD05A-XXX-XXX-B)	(1)	95982	[A]
	(PE05A-XXX-XXX-B)	(1)	96464	[A]
⑤ 137	"O" Ring (1/16" x 1-5/8" o.d.)	(2)	Y325-29	[B]
⑤ 138	"U" Cup Packing (1/8" x 1" o.d.)	(1)	94395	[U]
⑤ 139	"U" Cup Packing (1/8" x 1-7/16" o.d.)	(1)	96383	[U]

Item	Description (size)	Qty	Part No.	Mtl
140	Valve Insert	(1)	93276	[Ck]
141	Valve Plate	(1)	96173	[Ck]
① ⑤ 144	"U" Cup Packing (3/16" x 1" o.d.)	(2)	Y187-48	[B]
⑤ 167	Pilot Piston (includes 168 and 169)	(1)	67382	[D]
168	"O" Ring (1/16" x 7/16" o.d.)	(2)	96459	[U]
169	"U" Cup Packing (1/8" x 5/8" o.d.)	(1)	96384	[U]
170	Spool Bushing	(1)	96090	[D]
⑤ 171	"O" Ring (1/16" x 13/16" o.d.)	(2)	Y325-17	[B]
⑤ 173	"O" Ring (3/32" x 7/8" o.d.)	(2)	Y325-115	[B]
① ⑤ 174	"O" Ring (3/32" x 11/32" o.d.)	(2)	Y325-105	[B]
⑤ 200	Porting Gasket	(1)	96364	[B]
201	Muffler	(1)	93110	[C]
⑤ 232	"O" Ring (1/16" x 3/8" o.d.)	(4)	Y325-10	[B]
250	Screw (1/4" - 14 x 1/2" o.d.)	(1)	Y334-104-C	[C]
① ⑤	Lubriplate FML-2 grease	(1)	94276	
	Lubriplate Grease Packets (10)		637308	

① Indicates parts included in fluid section service kit, see page 4.

MATERIAL CODE

[A] = Aluminum	[D] = Acetal
[B] = Nitrile	[SS] = Stainless Steel
[C] = Carbon Steel	[U] = Polyurethane
[Ck] = Ceramic	[Z] = Zinc

AIR MOTOR SECTION SERVICE

Service is divided into two parts - 1. Pilot Valve, 2. Major Valve.

- Air Motor Section service is continued from Fluid Section repair.

PILOT VALVE DISASSEMBLY

- Remove (123) screws, releasing (103) covers, (121) washers, (118) actuator pins and (167) pilot piston.
- Remove (170) spool bushing and inspect inner bore of bushing for damage.

PILOT VALVE REASSEMBLY

- Clean and lubricate parts not being replaced from service kit.
- Assemble (171) "O" rings to (170) bushing and assemble bushing into (101) center body.
- Lubricate and assemble (167) pilot piston assembly into (170) bushing.
- Assemble (173 and 174) "O" rings and (121) washers to (103) covers, then insert (118) actuator pins through assembly.
- Assemble (144) "U" cups (note the lip direction) and (103) covers to (101) center body, securing with (123) screws. NOTE: tighten (123) screws to 10 - 12 in. lbs (1.13 - 1.36 Nm).

MAJOR VALVE DISASSEMBLY

- Unthread (134) bolts, releasing (129) exhaust cover.
- Pull (135) valve block and components from (101) center body.
- Remove (132) gasket, (141) valve plate and (140) valve insert from (135) valve block.
- Remove (134) bolts, releasing (136) plug and (111) spool.

MAJOR VALVE REASSEMBLY

- Assemble new (139 and 138) "U" cups on (111) spool - **LIPS MUST FACE EACH OTHER.**
- Assemble (137) "O" rings to (136) large plug.
- Insert (111) spool into (136) large plug, then insert (136) large plug into (135) valve block, being sure the (111) spool is rotated to accept (140) valve insert.
- Assemble (140) valve insert and (141) valve plate to (135) valve block. NOTE: Assemble (140) valve insert with "dished" side toward (141) valve plate. Assemble (141) valve plate with identification dot toward (132) gasket.
- Assemble (132 and 200) gaskets, (135) valve block, (130) gasket and (129) exhaust cover to (101) center body, securing with (134) bolts. NOTE: Tighten (134) bolts to 15 - 20 in. lbs (1.7 - 2.3 Nm).

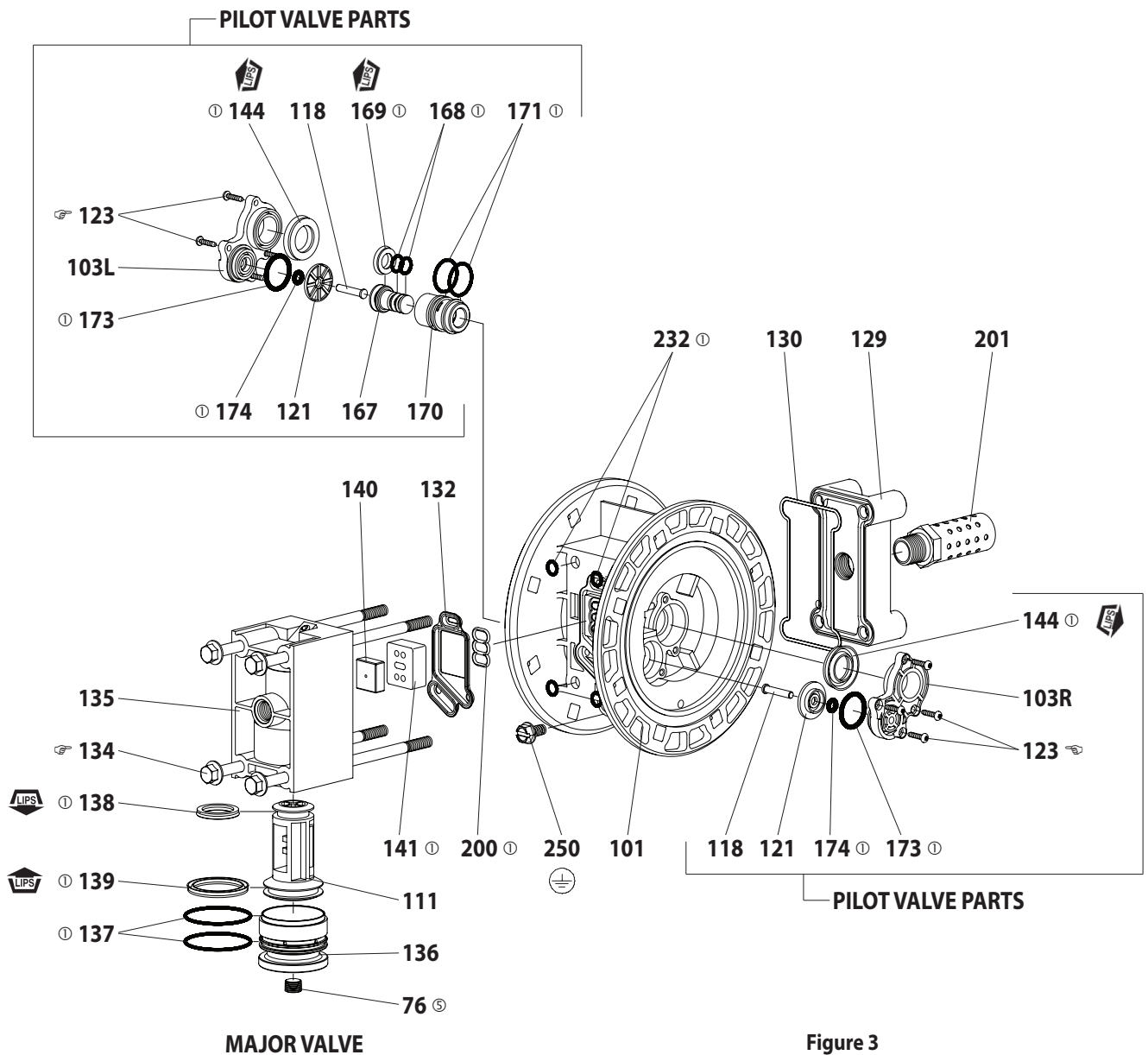

Figure 3

ASSEMBLY TORQUE REQUIREMENTS

NOTE: DO NOT OVERTIGHTEN FASTENERS.

(123) screw, 10 - 12 in. lbs (1.13 - 1.36 Nm).

(134) bolt, torque to 15 - 20 in. lbs (1.7 - 2.3 Nm), wait 10 minutes, then re-torque to 15 - 20 in. lbs (1.7 - 2.3 Nm).

LUBRICATION / SEALANTS

① Apply Lubriplate FML-2 grease to all "O" rings, "U" cups and mating parts.

⑤ Apply Loctite® 572™ to threads.

PARTS LIST / PX05R-XXX-XXX-B AIR MOTOR SECTION

⑤ Indicates parts included in 637428 air section service kit.

AIR MOTOR PARTS LIST

Item	Description (size)	Qty	Part No.	Mtl
101	Center Body	(1)	96315	[PPG]
103R	Cover (right side)	(1)	96091	[D]
103L	Cover (left side)	(1)	96351	[D]
107	Plug, Small	(1)	96353	[D]
111	Major Valve Spool	(1)	95919	[D]
118	Actuator Pin	(2)	97111	[SS]
⑤ 121	Washer	(2)	96092	[D]
123	Screw (#4 - 20 x 1/2")	(8)	96093	[SS]
129	Muffler Assembly	(1)	67367	[PPG]
④ 129	Exhaust Cover (optional)	(1)	67366	[PPG]
④ 130	Gasket (optional)	(1)	93107	[Sy]
⑤ 132	Air Manifold Gasket	(1)	96214-1	[B]
134	Flange Bolt (1/4" - 20 x 5-3/4")	(4)	94871	[SS]
135	Valve Block	(1)	96204	[PPG]
136	Plug, Large (PD05R-XXX-XXX-B)	(1)	96352	[D]
	(PE05R-XXX-XXX-B)	(1)	96462	[D]
⑤ 137	"O" Ring (1/16" x 1-5/8" o.d.)	(3)	Y325-29	[B]
⑤ 138	"U" Cup Packing (1/8" x 1" o.d.)	(1)	94395	[U]
⑤ 139	"U" Cup Packing (1/8" x 1-7/16" o.d.)	(1)	96383	[U]

Item	Description (size)	Qty	Part No.	Mtl
140	Valve Insert	(1)	93276	[Ck]
141	Valve Plate	(1)	96173	[Ck]
① ⑤ 144	"U" Cup Packing (3/16" x 1" o.d.)	(2)	Y187-48	[B]
⑤ 166	"O" Ring (1/16" x 1-1/4" o.d.)	(1)	Y325-24	[B]
⑤ 167	Pilot Piston (includes 168 and 169)	(1)	67382	[D]
168	"O" Ring (1/16" x 7/16" o.d.)	(2)	96459	[U]
169	"U" Cup Packing (1/8" x 5/8" o.d.)	(1)	96384	[U]
170	Spool Bushing	(1)	96090	[D]
⑤ 171	"O" Ring (1/16" x 13/16" o.d.)	(2)	Y325-17	[B]
⑤ 173	"O" Ring (3/32" x 7/8" o.d.)	(2)	Y325-115	[B]
① ⑤ 174	"O" Ring (3/32" x 11/32" o.d.)	(2)	Y325-105	[B]
⑤ 200	Porting Gasket	(1)	96364	[B]
201	Muffler (optional)	(1)	93110	[C]
④ 232	"O" Ring (1/16" x 3/8" o.d.) (optional)	(4)	Y325-10	[B]
④	Ported Exhaust Kit (includes items 129, 130 and 232) (optional)	(1)	637438	---
① ⑤	Lubriplate FML-2 grease	(1)	94276	
	Lubriplate Grease Packets (10)		637308	

① Indicates parts included in fluid section service kit, see page 4.

MATERIAL CODE

[B] = Nitrile	[PPG] = Glass filled Polypropylene
[C] = Carbon Steel	[SS] = Stainless Steel
[Ck] = Ceramic	[Sy] = Syn-Seal
[D] = Acetal	[U] = Polyurethane

AIR MOTOR SECTION SERVICE

Service is divided into two parts - 1. Pilot Valve, 2. Major Valve.

- Air Motor Section service is continued from Fluid Section repair.

PILOT VALVE DISASSEMBLY

- Remove (123) screws, releasing (103) covers, (121) washers, (118) actuator pins and (167) pilot piston.
- Remove (170) spool bushing and inspect inner bore of bushing for damage.

PILOT VALVE REASSEMBLY

- Clean and lubricate parts not being replaced from service kit.
- Assemble (171) "O" rings to (170) bushing and assemble bushing into (101) center body.
- Lubricate and assemble (167) pilot piston assembly into (170) bushing.
- Assemble (173 and 174) "O" rings and (121) washers to (103) covers, then insert (118) actuator pins through assembly.
- Assemble (144) "U" cups (note the lip direction) and (103) covers to (101) center body, securing with (123) screws. NOTE: tighten (123) screws to 4 - 6 in. lbs (0.45 - 0.68 Nm).

MAJOR VALVE DISASSEMBLY

- Unthread (134) bolts, releasing (129) muffler assembly.
- Pull (135) valve block and components from (101) center body.
- Remove (132) gasket, (141) valve plate and (140) valve insert from (135) valve block.
- Remove (134) bolts, releasing (107 and 136) plugs and (111) spool.

MAJOR VALVE REASSEMBLY

- Assemble new (139 and 138) "U" cups on (111) spool - **LIPS MUST FACE EACH OTHER.**
- Assemble (137) "O" rings to (136) large plug.
- Assemble (137 and 166) "O" rings to (107) small plug.
- Insert (111) spool into (136) large plug, then insert (136) large plug into (135) valve block, being sure the (111) spool is rotated to accept (140) valve insert.
- Assemble (107) small plug into (135) valve block.
- Assemble (140) valve insert and (141) valve plate to (135) valve block. NOTE: Assemble (140) valve insert with "dished" side toward (141) valve plate. Assemble (141) valve plate with identification dot toward (132) gasket.
- Assemble (132 and 200) gaskets, (135) valve block and (129) muffler assembly to (101) center body, securing with (134) bolts. NOTE: Tighten (134) bolts to 15 - 20 in. lbs (1.7 - 2.3 Nm).

PARTS LIST / PX05R-XXX-XXX-B AIR MOTOR SECTION

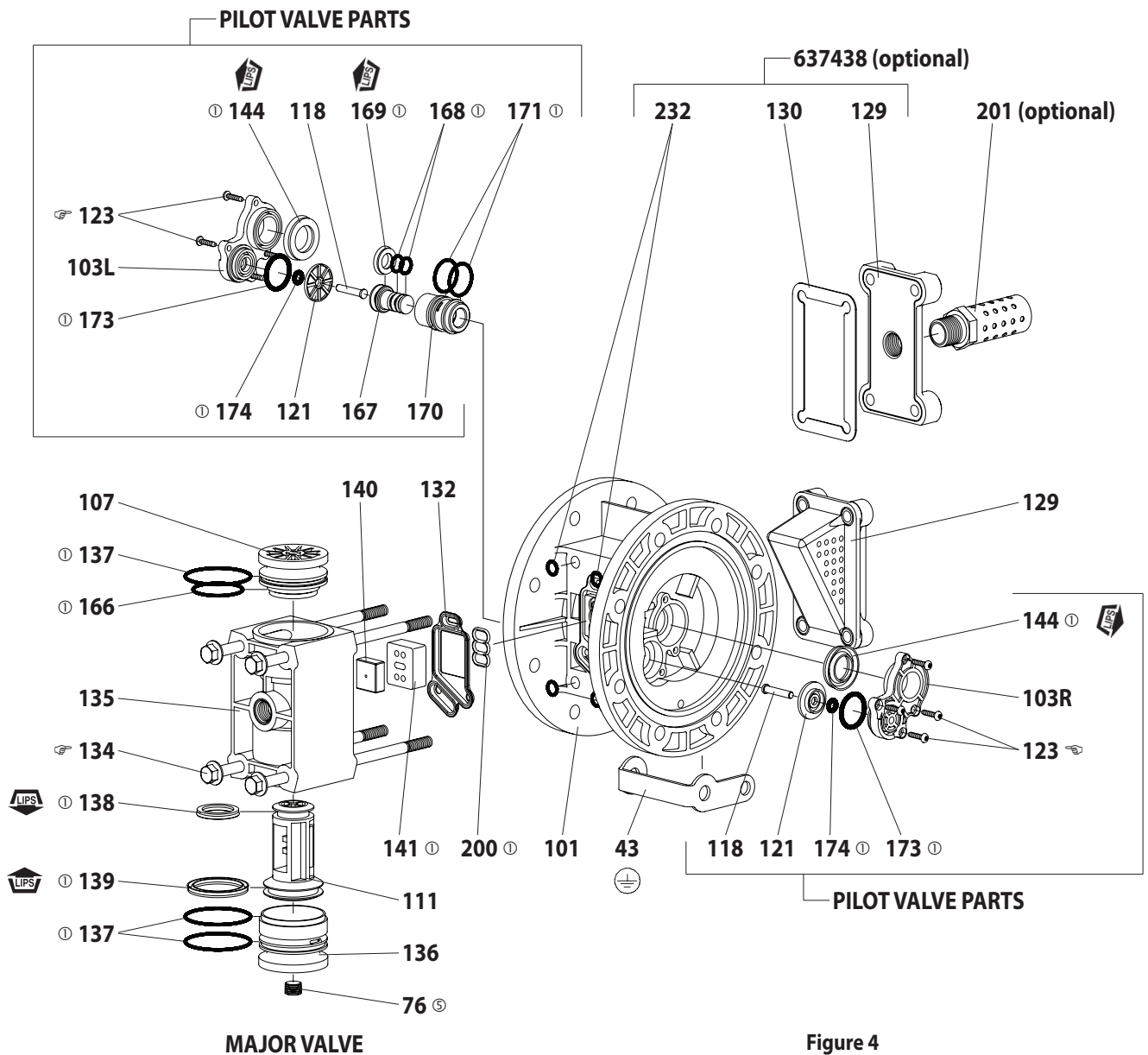

Figure 4

ASSEMBLY TORQUE REQUIREMENTS

NOTE: DO NOT OVERTIGHTEN FASTENERS.

(123) screw, 4 - 6 in. lbs (0.45 - 0.68 Nm).

(134) bolt, torque to 15 - 20 in. lbs (1.7 - 2.3 Nm), wait 10 minutes, then re-torque to 15 - 20 in. lbs (1.7 - 2.3 Nm).

LUBRICATION / SEALANTS

① Apply Lubriplate FML-2 grease to all "O" rings, "U" cups and mating parts.

⑤ Apply Loctite® 572™ to threads.

TYPICAL CROSS SECTION

Models PE05A-XXS-XXX-B

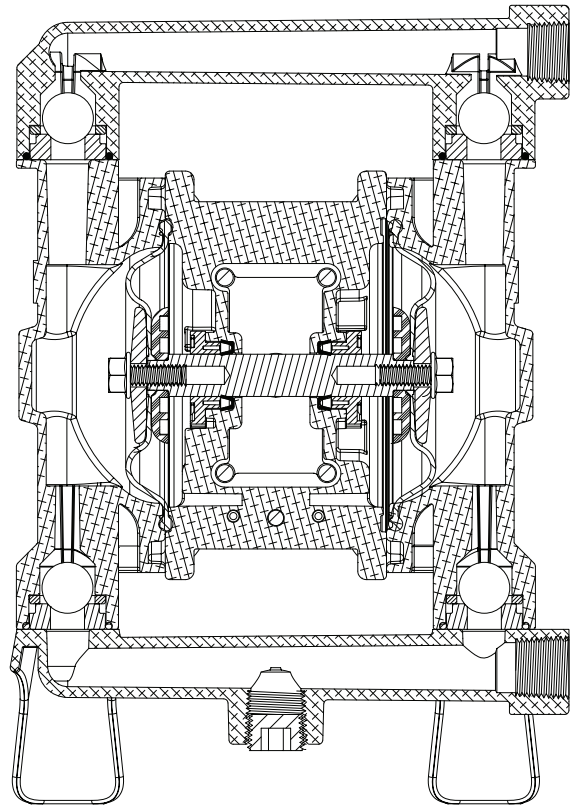
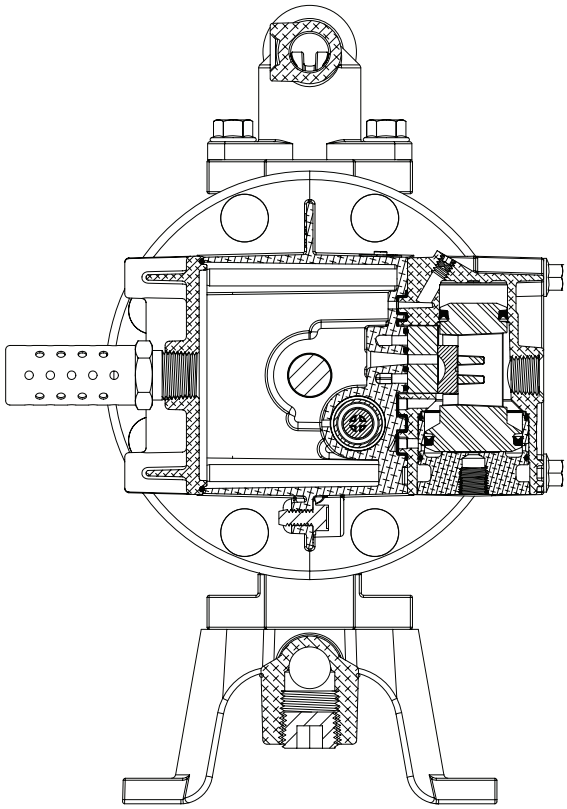

Models PE05R-XXS-XXX-B

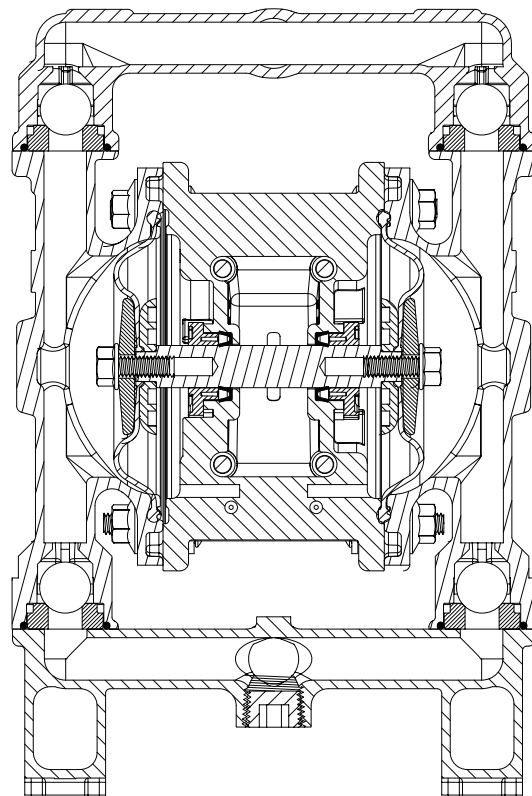
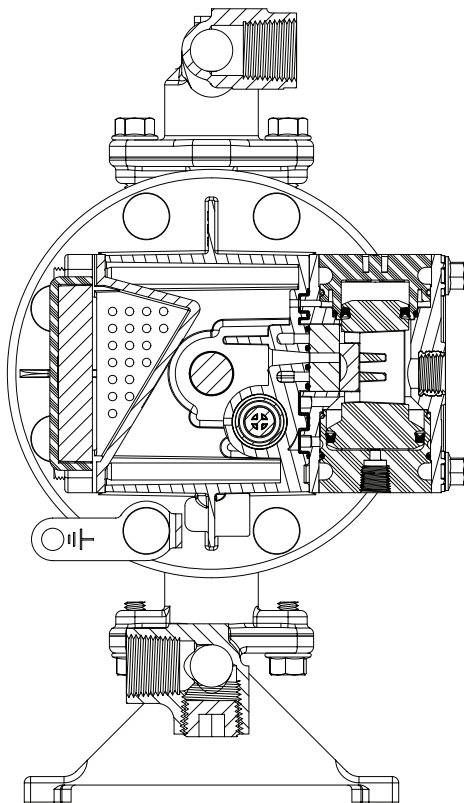

Figure 5

TROUBLE SHOOTING

Product discharged from exhaust outlet.

- Check for diaphragm rupture.
- Check tightness of (14) bolt.

Air bubbles in product discharge.

- Check connections of suction plumbing.
- Check "O" rings between intake manifold and fluid caps.
- Check tightness of (14) bolt.

Motor blows air out main exhaust when stalled on either stroke.

- Check "U" cups on (111) spool in major valve.
- Check (141) valve plate and (140) insert for wear.
- Check (169) "U" cup on (167) pilot piston.

Low output volume.

- Check air supply.
- Check for plugged outlet hose.
- For the pump to prime itself, it must be mounted in the vertical position so that the balls will check by gravity.
- Check for pump cavitation - suction pipe should be sized at least as large as the inlet thread diameter of the pump for proper flow if high viscosity fluids are being pumped. Suction hose must be a non-collapsing type, capable of pulling a high volume.
- Check all joints on the inlet manifolds and suction connections. These must be air tight.
- Inspect the pump for solid objects lodged in the diaphragm chamber or the seat area.

DIMENSIONAL DATA / PX05A-XXS-XXX-B

Dimensions shown are for reference only, they are displayed in inches and millimeters (mm).

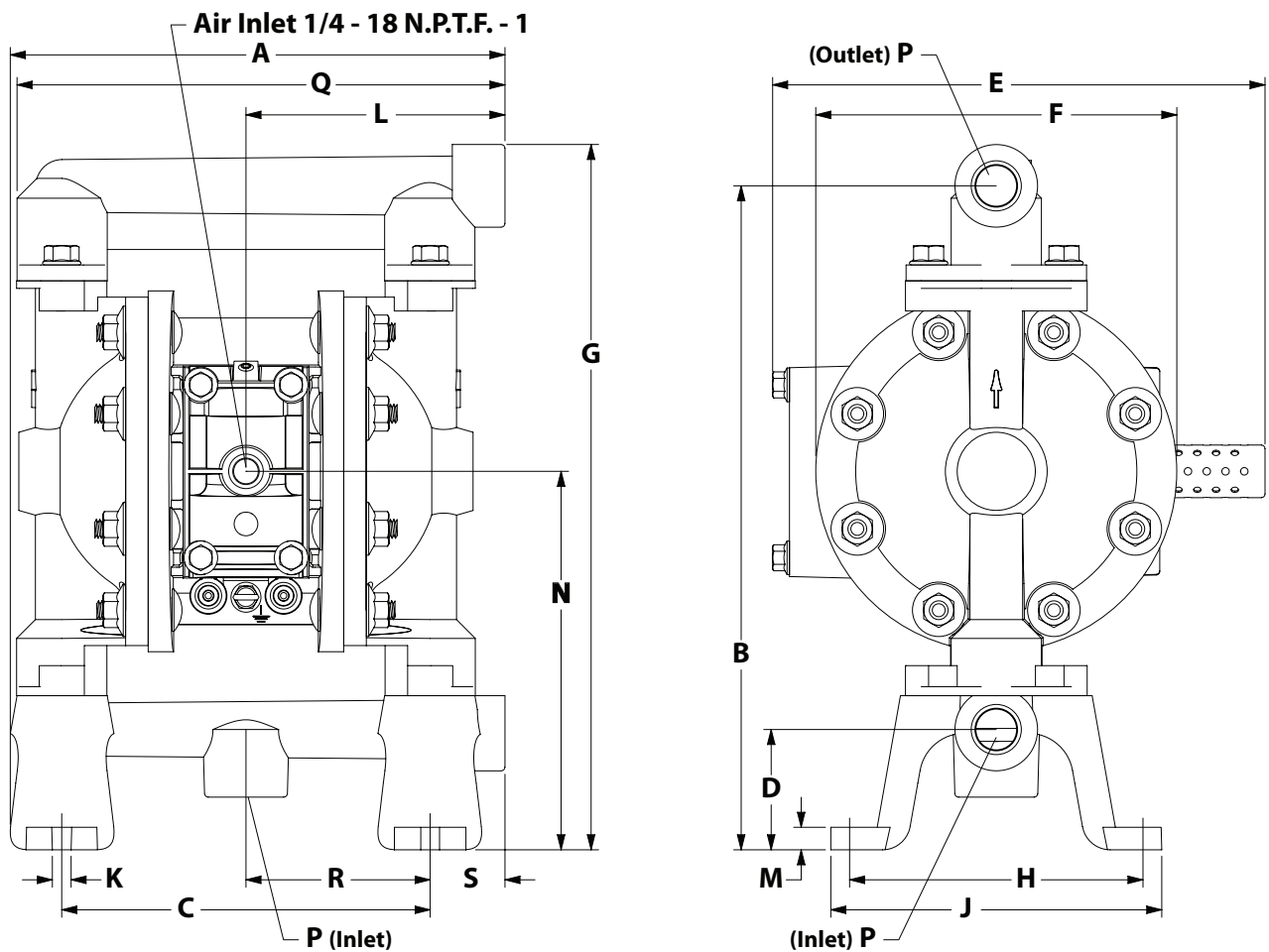

DIMENSIONS

A - 8-7/32" (208.5 mm)	F - 6" (152.4 mm)	L - 4-5/16" (109.3 mm)	R - 3-1/16" (77.8 mm)
B - 11-1/16" (280.4 mm)	G - 11-3/4" (297.9 mm)	M - 3/8" (9.5 mm)	S - 1-1/4" (31.8 mm)
C - 6-1/8" (155.5 mm)	H - 4-7/8" (123.8 mm)	N - 6-5/16" (159.9 mm)	
D - 2" (50.8 mm)	J - 5-1/2" (139.6 mm)	P - see below	
E - 8-3/16" (207.9 mm)	K - 5/16" (7.9 mm)	Q - 8-1/8" (206.0 mm)	

Pump Model
 PX05A-~~AXS~~-XXX-B
 PX05A-~~BXS~~-XXX-B

"P" Material Inlet / Outlet
 1/2 - 14 N.P.T.F. - 1
 Rp 1/2 (1/2 - 14 BSP, parallel)

Figure 6

DIMENSIONAL DATA / PX05R-XXS-XXX-B

Dimensions shown are for reference only, they are displayed in inches and millimeters (mm).

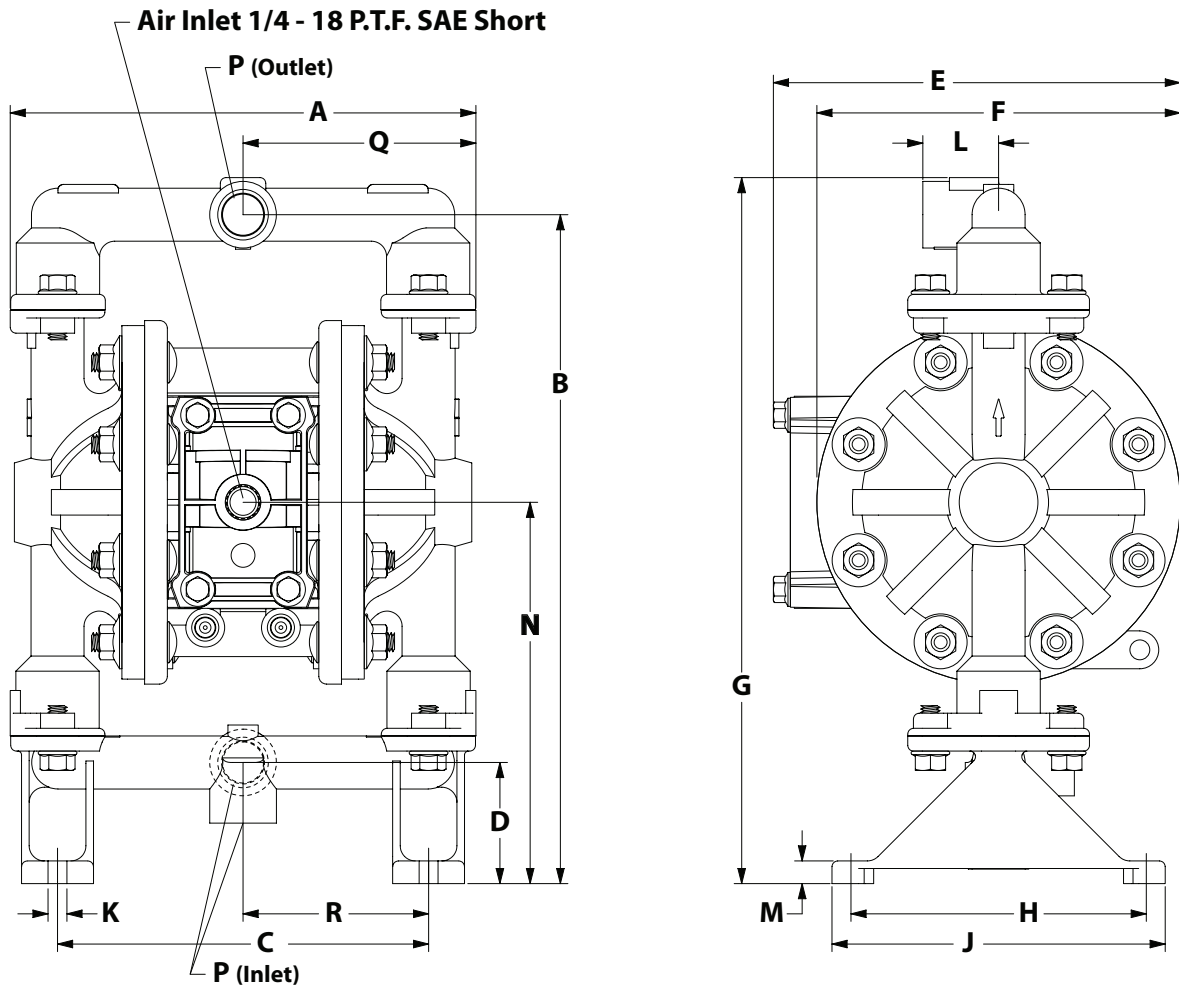

A - 7-11/16" (195.2 mm)
 B - 11-1/16" (280.4 mm)
 C - 6-1/8" (155.6 mm)
 D - 2" (50.8 mm)

E - 6-23/32" (170.6 mm)
 F - 6" (152.4 mm)
 G - 11-21/32" (296.0 mm)
 H - 4-7/8" (123.8 mm)

J - 5-1/2" (139.7 mm)
 K - 5/16" (7.9 mm)
 L - 1-1/4" (31.8 mm)
 M - 3/8" (9.5 mm)

N - 6-5/16" (160.0 mm)
 P - see below
 Q - 3-27/32" (97.6 mm)
 R - 3-1/16" (77.8 mm)

DIMENSIONS

Pump Model
 PX05R-~~A~~XS-XXX-B
 PX05R-~~B~~XS-XXX-B

"P" Material Inlet / Outlet
 1/2 - 14 N.P.T.F. - 1
 Rp 1/2 (1/2 - 14 BSP, parallel)

Figure 7