



Vestil Manufacturing Co.

2999 North Wayne Street, P.O. Box 507, Angola, IN 46703
 Telephone: (260) 665-7586 -or- Toll Free (800) 348-0868
 Fax: (260) 665-1339
 Web: www.vestilmfg.com e-mail: info@vestil.com

WTJ-2 Series Vehicle Mounted Jib Cranes Instruction Manual



Receiving Instructions

After delivery, remove the packaging from the product. Inspect the product closely to determine whether it sustained damage during transport. If damage is discovered, record a complete description of it on the bill of lading. If the product is undamaged, discard the packaging.

NOTE: The end-user is solely responsible for confirming that product design, use, and maintenance comply with laws, regulations, codes, and mandatory standards applied where the product is used.

Technical Service & Replacement Parts Department

For answers to questions not addressed in these instructions and to order replacement parts, labels, and accessories, call our Technical Service and Parts Department at (260) 665-7586. The Department can also be contacted online at <https://www.vestil.com/page-parts-request.php>.

Electronic Copies of Instruction Manuals

Additional copies of this instruction manual may be downloaded from <https://www.vestil.com/page-manuals.php>.

Table of Contents

	Page
Specifications	2
Exploded View: WTJ-2	3
Bills of Materials: WTJ-2 & WTJ-2-G	4
Exploded View: WTJ-2-G & WTJ-2-SS	5
Bill of Materials: WTJ-2-SS	6
Assembling the Crane	6
Signal Words	7
Safety Instructions	7
Installing the Crane in a Fixed Location (Not in a Vehicle)	8
Installing the Crane on a Vehicle	8
Raising and Lowering the Boom	9
Boom Length Adjustments	9
Using the Crane	9 - 10
Record of Satisfactory Condition	10
Inspections	10
Troubleshooting	11
Labeling Diagram	11
Limited Warranty	12

SPECIFICATIONS

Crane dimensions, capacity, and net weight appear in the diagram and table below. Specifications may change without notice.

WTJ-2

Mounting plate dimensions

3D model shown for reference

Lifting bale capacities:
 Boom extended ("long") = 500 lb. (227.3kg)
 Boom retracted ("short") = 1,000 lb. (454.5kg)

Winch & winch hook capacity = 500 lb. (227.2kg)

Fixed hook capacity = 500 lb. (227.2kg)

Winch hook heights:
 Cylinder extended & boom extended = 102" (259cm)
 Cylinder extended & boom retracted = 89 1/2" (227cm)
 Cylinder retracted & boom extended = 0" (0cm)
 Cylinder retracted & boom retracted = 10" (25cm)

Cable dimensions:
 Overall length = 14 1/2 ft. (4.4m)
 Usable length = 9 ft. (2.7m)

Usable reach:
 Boom horizontal & extended = 54" (137cm)
 Boom horizontal & retracted = 30 1/4" (77cm)

Net weight of crane = 135 lb. (61.4kg)

WTJ-2-G & WTJ-2-SS

Mounting plate dimensions

3D model shown for reference

Lifting bale capacities:
 Boom extended ("long") = 500 lb. (227.3kg)
 Boom retracted ("short") = 1,000 lb. (454.5kg)

Winch & winch hook capacity = 500 lb. (227.2kg)

Fixed hook capacity = 500 lb. (227.2kg)

Winch hook heights:
 Cylinder extended & boom extended = 99" (39cm)
 Cylinder extended & boom retracted = 84" (33cm)
 Cylinder retracted & boom extended = 0" (0cm)
 Cylinder retracted & boom retracted = 12 1/2" (32cm)

Cable dimensions:
 Overall length = 32 ft. (9.8m)
 Usable length = 24 ft. (7.3m)

Usable reach:
 Boom horizontal & fully extended = 52" (132cm)
 Boom horizontal & fully retracted = 30 1/2" (78cm)

Net weight of crane: = 218 lb. (99.1kg)

WTJ-2 EXPLODED VIEW (BILLS OF MATERIALS ON P. 4 & 5)

Boom configuration	Fixed hook capacity	Winch hook capacity
A (short boom)	1,000 lb. (454 kg)	500 lb. (227 kg)
B (long boom)	500 lb. (227 kg)	500 lb. (227 kg)

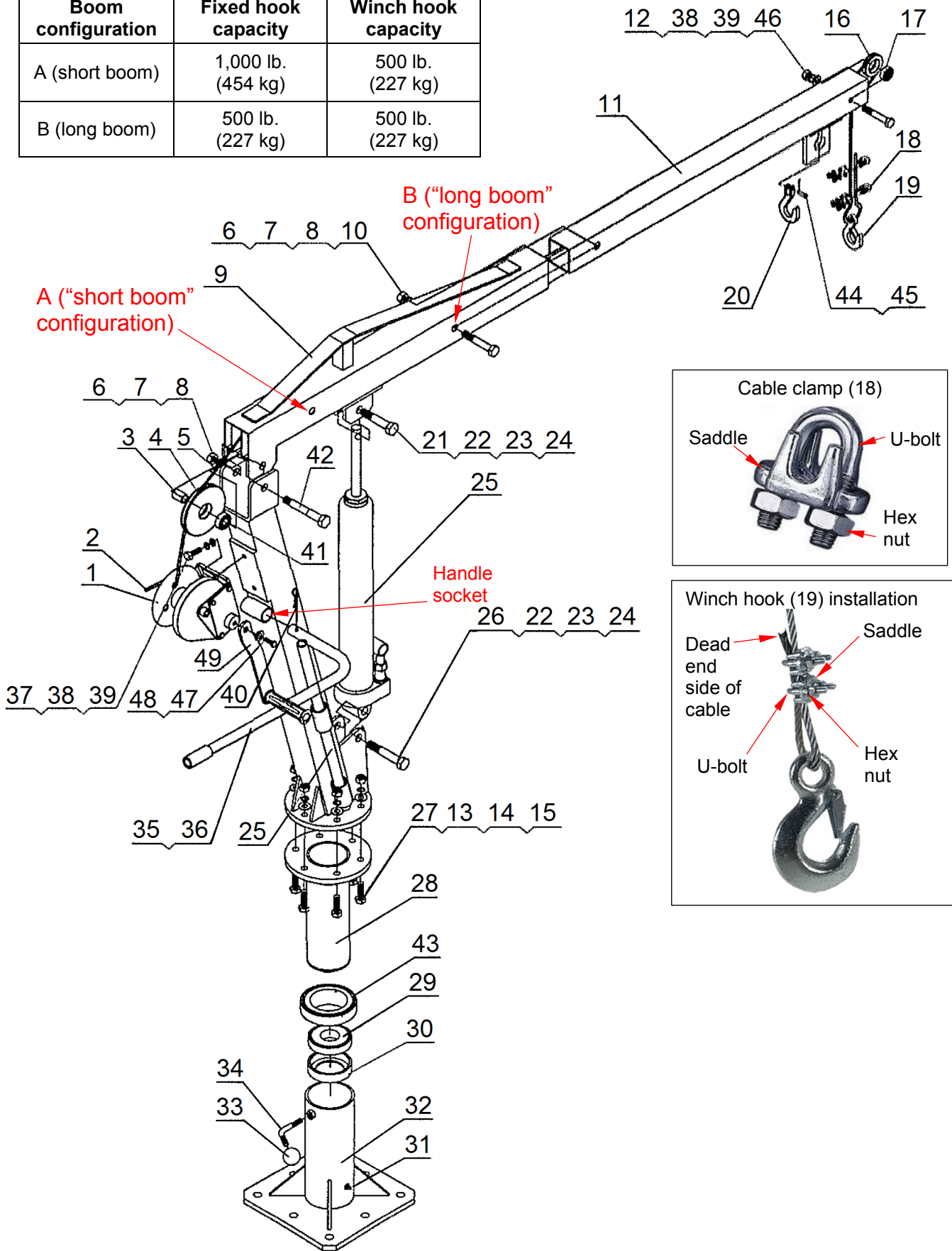

WTJ-2 BILL OF MATERIALS

Item	Part no.	Description	Qty.	Item	Part no.	Description	Qty.
1	WTJ-2-11-1	Winch without handle	1	26	WTJ-2-11-26	Bolt, hex head, M16-2.0x90	1
2	WTJ-2-11-2	Cable, winch	1	27	WTJ-2-11-27	Bolt, hex head, M12-1.75x40	6
3	WTJ-2-11-3	Bushing (not used after 2010)	1	28	WTJ-2-11-28	Turntable	1
4	WTJ-2-11-4	Pulley, large	1	29	WTJ-2-11-29	Bearing, tapered ball with race	1
5	WTJ-2-11-5	Post, main ("mast")	1	30	WTJ-2-11-30	Cup, bearing	1
6	WTJ-2-11-6	Nut, hex, M14	2	31	WTJ-2-11-31	Zerk, grease	1
7	WTJ-2-11-7	Washer, lock, M14	2	32	WTJ-2-11-32	Base without hardware	1
8	WTJ-2-11-8	Washer, flat, M14	2	33	WTJ-2-11-33	Knob, locking handle	1
9	WTJ-2-11-9	Boom, outer	1	34	WTJ-2-11-34	Bolt, turntable locking	1
10	WTJ-2-11-10	Pin with chain and hitch clip	1	35	WTJ-2-11-35	Handle, swivel	1
11	WTJ-2-11-11	Boom, telescoping	1	36	WTJ-2-11-36	Grip, handle	2
12	WTJ-2-11-12	Bolt, hex head, M10-1.5x80	1	37	WTJ-2-11-37	Bolt, hex head, M10-1.5x20mm	2
13	WTJ-2-11-13	Nut, hex, M12	6	38	WTJ-2-11-38	Washer, lock, M10	2
14	WTJ-2-11-14	Washer, lock, M12	6	39	WTJ-2-11-39	Washer, flat, M10	2
15	WTJ-2-11-15	Washer, flat, M12x24mm	6	40	WTJ-2-11-40	R pin, M3	1
16	WTJ-2-11-16	Pulley, small	1	41	WTJ-2-11-41	Bearing, ball, 6202-ZZ	1
17	WTJ-2-11-17	Bearing, ball	1	42	WTJ-2-11-42	Bolt, special shouldered	1
18	WTJ-2-11-18	Clamp, wire, 1/4"	2	43	WTJ-2-11-43	Bushing	1
19	WTJ-2-11-19	Hook, retractable/winch	1	44	WTJ-2-11-44	Pin, M12x40	1
20	WTJ-2-11-20	Hook, fixed	1	45	WTJ-2-11-45	Pin, cotter, M2x25	1
21	WTJ-2-11-21	Bolt, hex head, M16-2.0x90	1	46	WTJ-2-11-46	Nut, hex, M10	1
22	WTJ-2-11-22	Nut, hex, M16	2	47	WTJ-2-11-47	Bolt, hex head, M8-1.25x25	1
23	WTJ-2-11-23	Washer, lock, M16	2	48	WTJ-2-11-48	Washer, flat, M8	1
24	WTJ-2-11-24	Washer, flat, M16	2	49	WTJ-2-11-49	Handle, winch	1
25	WTJ-2-11-25 WTJ-2-11-25A	Jack, hydraulic, 3-ton Handle, jack	1				

*Knob might be molded to end of locking bolt (34). **Grip might already be installed on mast handle (35).

WTJ-2-G BILL OF MATERIALS

Item	Part no.	Description	Qty.	Item	Part no.	Description	Qty.
1	WTJ-2-G-1	Winch without handle	1	23	WTJ-2-G-23	Washer, lock, M16	3
2	WTJ-2-G-2	Cable, winch	1	24	WTJ-2-G-24	Washer, flat, M16	3
3	WTJ-2-G-3	Bushing (not used after 2010)	1	25	WTJ-2-G-25	Jack, hydraulic, 3-ton	1
4	WTJ-2-G-4	Pulley, large	1	26	WTJ-2-G-26	Bolt, hex head, M16-2.0x90	1
5	WTJ-2-G-5	Post, main ("mast")	1	27	WTJ-2-G-27	Bolt, hex head, M12-1.75x40	6
6	WTJ-2-G-6	Nut, Nylon, lock, M14	1	28	WTJ-2-G-28	Turntable	1
7	WTJ-2-G-7	Washer, lock, M14	1	29	WTJ-2-G-29	Bearing, tapered ball	1
8	WTJ-2-G-8	Washer, flat, M14	1	30	WTJ-2-G-30	Sleeve, bearing	1
9	WTJ-2-G-9	Boom, outer	1	31	WTJ-2-G-31	Zerk, grease	1
10	WTJ-2-G-10	Bolt, hex head, M14-2.0x100mm	1	32	WTJ-2-G-32	Base without hardware	1
11	WTJ-2-G-11	Boom, telescoping	1	*33	WTJ-2-G-33	Knob, locking handle	1
12	WTJ-2-G-12	Bolt, hex head, M10-1.75x85	1	34	WTJ-2-G-34	Bolt, turntable locking	1
13	WTJ-2-G-13	Nut, Nylon, lock M12	7	35	WTJ-2-G-35	Handle, swivel	1
14	WTJ-2-G-14	Washer, lock, M12	7	*36	WTJ-2-G-36	Grip, handle	1
15	WTJ-2-G-15	Washer, flat, M12x24mm	7	37	WTJ-2-G-37	Bolt, hex head, M10-1.5x20mm	3
16	WTJ-2-G-16	Pulley, small with bearing	1	38	WTJ-2-G-38	Washer, lock, M10	3
17	WTJ-2-G-17	Bearing, ball, 6201-RS	1	39	WTJ-2-G-39	Washer, flat, M10	3
18	WTJ-2-G-18	Clamp, wire, 1/4"	2	40	WTJ-2-G-40	Hitch pin, M3	1
19	WTJ-2-G-19	Hook, retractable/winch	1	41	WTJ-2-G-41	Bearing, ball, 6202-ZZ	1
20	WTJ-2-G-20	Hook, fixed, with chain	1	42	WTJ-2-G-42	Bolt, special shouldered	1
21	WTJ-2-G-21	Bolt, hex head, M16-2.0x90	1	43	WTJ-2-G-43	Bushing	1
22	WTJ-2-G-22	Nut, Nylon, lock, M16	3	44	WTJ-2-G-44	Handle, pump	1

*Knob might be molded to end of locking bolt (34). **Grip might already be installed on mast handle (35).

WTJ-2-G & WTJ-2-SS EXPLODED VIEW (BILL OF MATERIALS ON P. 4)

Boom configuration	Fixed hook capacity	Winch hook capacity
A (short boom)	2,000 lb. (909.1 kg)	500 lb. (227.3 kg)
B (long boom)	1,000 lb. (454.5 kg)	500 lb. (227.3 kg)

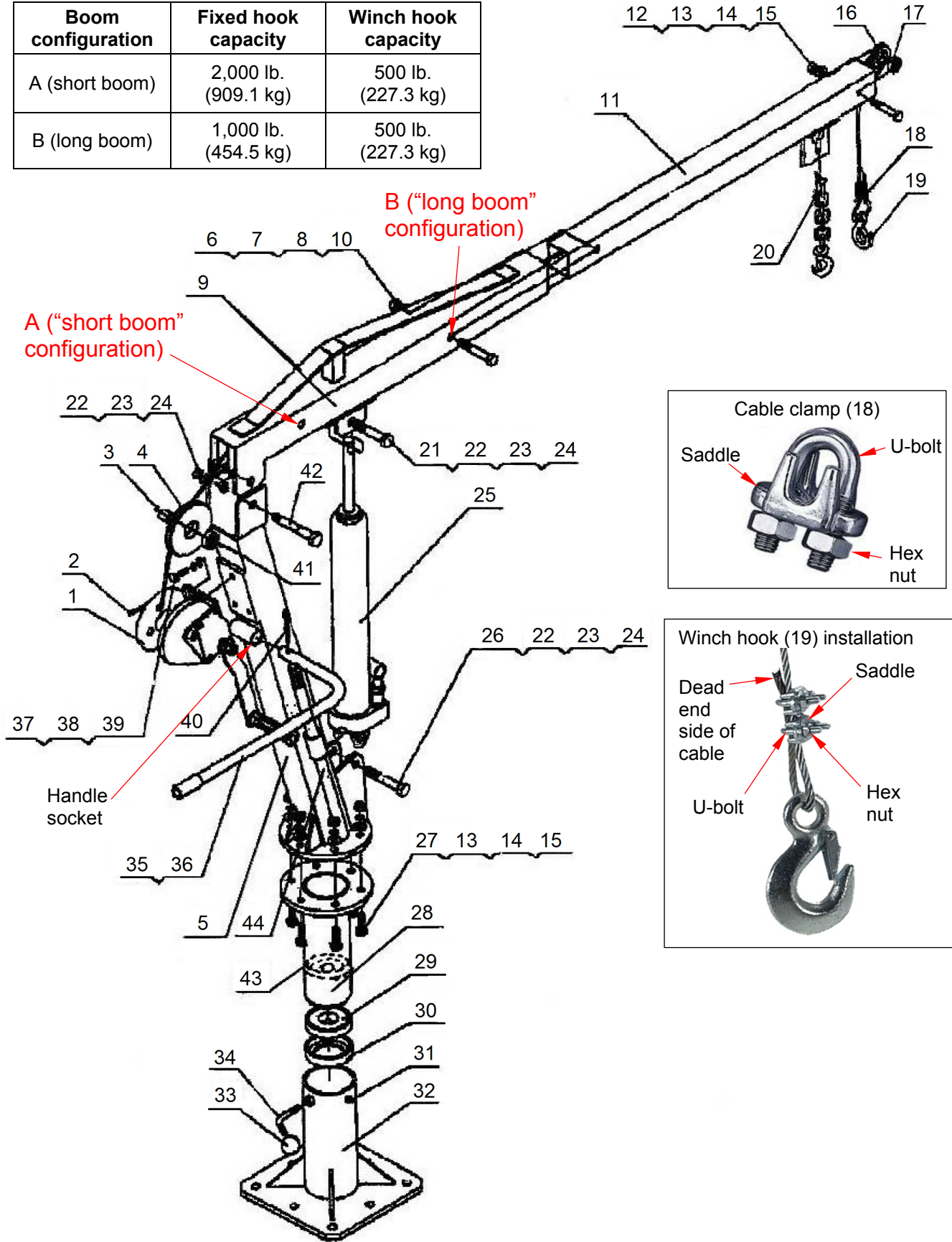

WTJ-2-SS BILL OF MATERIALS (SEE EXPLODED VIEW ON P. 5)

Item	Part no.	Description	Qty.	Item	Part no.	Description	Qty.
1	WTJ-2-SS-1	Winch without handle	1	23	WTJ-2-SS-23	Washer, lock, M16	3
2	WTJ-2-SS-2	Cable, winch	1	24	WTJ-2-SS-24	Washer, flat, M16	3
3	WTJ-2-SS-3	Bushing (not used after 2010)	1	25	WTJ-2-SS-25	Jack, hydraulic, 3-ton	1
4	WTJ-2-SS-4	Pulley, large	1	26	WTJ-2-SS-26	Bolt, hex head, M16-2.0x90	1
5	WTJ-2-SS-5	Post, main ("mast")	1	27	WTJ-2-SS-27	Bolt, hex head, M12-1.75x40	6
6	WTJ-2-SS-6	Nut, Nylon, lock, M14	1	28	WTJ-2-SS-28	Turntable	1
7	WTJ-2-SS-7	Washer, lock, M14	1	29	WTJ-2-SS-29	Bearing, tapered ball	1
8	WTJ-2-SS-8	Washer, flat, M14	1	30	WTJ-2-SS-30	Sleeve, bearing	1
9	WTJ-2-SS-9	Boom, outer	1	31	WTJ-2-SS-31	Zerk, grease	1
10	WTJ-2-SS-10	Bolt, hex head, M14-2.0x100mm	1	32	WTJ-2-SS-32	Base without hardware	1
11	WTJ-2-SS-11	Boom, telescoping	1	*33	WTJ-2-SS-33	Knob, locking handle	1
12	WTJ-2-SS-12	Bolt, hex head, M10-1.75x85	1	34	WTJ-2-SS-34	Bolt, turntable locking	1
13	WTJ-2-SS-13	Nut, Nylon, lock M12	7	35	WTJ-2-SS-35	Handle, swivel	1
14	WTJ-2-SS-14	Washer, lock, M12	7	*36	WTJ-2-SS-36	Grip, handle	1
15	WTJ-2-SS-15	Washer, flat, M12x24mm	7	37	WTJ-2-SS-37	Bolt, hex head, M10-1.5x20mm	3
16	WTJ-2-SS-16	Pulley, small with bearing	1	38	WTJ-2-SS-38	Washer, lock, M10	3
17	WTJ-2-SS-17	Bearing, ball, 6201-RS	1	39	WTJ-2-SS-39	Washer, flat, M10	3
18	WTJ-2-SS-18	Clamp, wire, 1/4"	2	40	WTJ-2-SS-40	Hitch pin, M3	1
19	WTJ-2-SS-19	Hook, retractable/winch	1	41	WTJ-2-SS-41	Bearing, ball, 6202-ZZ	1
20	WTJ-2-SS-20	Hook, fixed, with chain	1	42	WTJ-2-SS-42	Bolt, special shouldered	1
21	WTJ-2-SS-21	Bolt, hex head, M16-2.0x90	1	43	WTJ-2-SS-43	Bushing	1
22	WTJ-2-SS-22	Nut, Nylon, lock, M16	3	44	WTJ-2-SS-44	Handle, pump	1

*Knob might be molded to end of locking bolt (34). **Grip might already be installed on mast handle (35).





ASSEMBLING THE CRANE

Refer to the exploded parts diagram for your crane (either on [p. 3](#) or on [p. 5](#)) and the corresponding bill of materials. Numbers in parentheses () correspond to item numbers in the diagrams.

- As shipped, the base/receiver (32), turntable locking knob and bolt (33 & 34), bearing cup (30), tapered roller bearing (29), bushing (43), and turntable (28) are assembled.
- Fasten the mast (5) to the turntable with M12x40mm bolts (27) and corresponding flat washers (15), lock washers (14), and hex nuts (13). Fasten the mast to the turntable with 6 sets of fasteners (27, 15, 14, and 13). Insert bolts upwards through the bolt holes.
- Attach the boom (9) and large pulley (4) to the top of the mast. Position the end of the boom inside the top of the mast and align bolt holes. Insert the M14 shoulder bolt (42; the bolt has a wide shoulder and a narrow shoulder) through the bolt holes on one side. Slide the large pulley (4) onto the free end of the bolt; then insert the bolt through the other side of the boom and mast. Secure it with an M14 flat washer (8), lock washer (7), and hex nut (6).
- Attach the pump (25) to the crane. First, attach the base of the pump to the mast using the M16x90mm hex bolt (26). The bolt is approximately 3.5 inches long. Secure the bolt with an M16 flat washer (24), lock washer (23), and hex nut (22). Next, attach the pump plunger/piston to the underside of the boom with the M16x80mm hex bolt (21). The bolt is just a bit longer than 3 inches. Secure the bolt with an M16 flat washer (24), lock washer (23), and hex nut (22).
- Slide the telescoping boom (11) into the boom. Fasten the booms together with an M14x100mm hex bolt (10) at either location A or location B. Install an M14 flat washer (8), lock washer (7), and hex nut (6).
NOTE: Instead of an M14x100 bolt, washers and nut, your hardware kit might include a clevis pin (with chain) and a hitch pin. Slide the clevis pin through the holes. Secure it with the hitch pin.
- Attach the winch (1) to the bracket on the back of the mast with two M10x20mm hex bolts (37). Secure each bolt with an M14 flat washer (39) and lock washer (38).
- Connect the winch handle (49) to the winch with an M8 flat washer (48; washer is thicker than an ordinary flat washer) and M8x25mm hex bolt (~1inch long).
- Install the small pulley (16) in the free end of the telescoping boom. Bearing (17) is already installed in the center of the pulley. Align the hole in the pulley with the bolt holes in the end of the boom and insert an M10x80mm hex bolt (12) through the holes. Secure the free end with an M10 flat washer (39), lock washer (38), and hex nut (46).
- Turn the winch handle counterclockwise to unwind cable. Unwind approximately 8 feet of cable. Feed the end of the cable over the groove in the top of the big pulley and through the boom, the telescoping boom and into the groove on top of the small pulley. Look at the underside of the telescoping boom. There is a rectangular slot near the end below the small pulley. Feed the end of the cable through the slot from the inside of the boom.
- Attach the winch hook (19) to the end of the cable. Feed 4-6 inches of cable through the circular eyelet in the top of the hook. Install cable clamps as shown in the "Winch hook installation" diagram on p. 3 or p. 5. Insert the U-bolts from the dead end side of the cable; then install the saddle and hex nuts. Securely tighten the nuts.
- Lift a test weight with the fixed hook equal to 125% of the rated capacity (1,250 lb.). Inspect the crane and the installation site after performing the load test. Look for cracks, warps, and other forms of damage at and around the installation site. Repair the site if necessary. Perform another load test to confirm that problems are resolved.



SIGNAL WORDS

This manual uses SIGNAL WORDS to call attention to uses of this product that are likely to result in personal injuries or property damage.

	Identifies a hazardous situation which, if not avoided, <u>WILL</u> result in DEATH or SERIOUS INJURY. Use of this signal word is limited to the most extreme situations.
	Identifies a hazardous situation which, if not avoided, COULD result in DEATH or SERIOUS INJURY.
	Indicates a hazardous situation which, if not avoided, COULD result in MINOR or MODERATE injury.
	Identifies practices likely to result in product/property damage, such as operation that might damage the product or other property.

SAFETY INSTRUCTIONS

Read the entire manual before using this crane. A copy of the manual should be available to operators at all times.

	Electrocution might occur if the crane, hoist, or load, etc. contacts electrified wires.
	<p>Improper or careless operation might result in serious personal injuries.</p> <ul style="list-style-type: none"> • ALWAYS apply use, inspection, and maintenance recommendations in 29 CFR 1910.179 as well as the instructions in this manual. Contact the occupational safety and health institution of the state where the crane is used for requirements applied to jib cranes. • DO NOT use a damaged or malfunctioning crane! Restore it to normal condition before returning it to service. Satisfactory condition is defined in INSPECTIONS on p. 10. • DO NOT exceed the capacity of your crane. See SPECIFICATIONS on p. 2 and EXPLODED VIEW on p. 3 or p. 5. The net weight of the load, rigging, and all other equipment attached to the crane must never exceed the capacity. <ul style="list-style-type: none"> ○ Lifting bale capacity is 1,000 pounds (454kg) when the boom is retracted/short; 500 pounds (227kg) when the boom is extended. ○ Winch hook capacity and chain hook capacity are always 500 pounds (227.3kg) regardless of boom length. • Inspect the crane according to the INSPECTION instructions on p. 10. • NO ONE should ever stand beneath or travel under a load suspended from the crane. • DO NOT use the crane to lift people. • ALWAYS use the crane as recommended in USING THE CRANE on p. 9-10. Failure to properly load the crane might cause the load to swing when it is lifted. Load swing might result in serious injury. • DO NOT use the crane if any label is unreadable, damaged, or missing. See LABELING DIAGRAM on p. 11. Contact Vestil for replacement labels. • DO NOT modify the crane! Modifications automatically void the LIMITED WARRANTY (p. 12) and might make the crane unsafe to use.

INSTALLING THE CRANE IN A FIXED LOCATION (NOT IN A VEHICLE)

Boom shown in "long" configuration

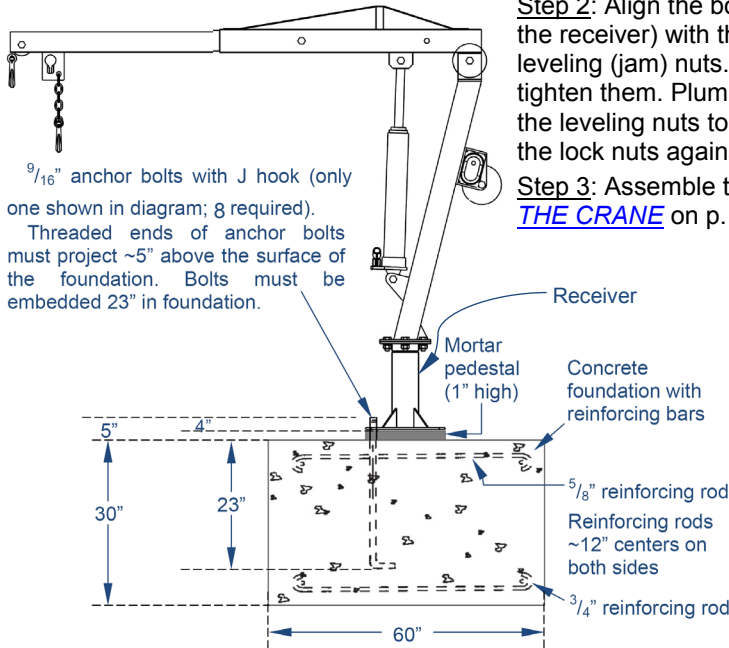

$\frac{9}{16}$ " anchor bolts with J hook (only one shown in diagram; 8 required). Threaded ends of anchor bolts must project ~5" above the surface of the foundation. Bolts must be embedded 23" in foundation.

Step 1: Create a foundation for the crane. The necessary minimum foundation requirements are shown in the diagrams. When the foundation is adequately cured, install a $\frac{7}{8}$ " jam nut on each anchor bolt. Wind the nuts to the surface of the foundation. Level across opposite jam nuts by raising or lowering specific nuts until all of the nuts are level. Then, fill the center of the bolt pattern (see "Overhead View of Foundation" diagram) with grout (e.g. Morta Mix) to create a pedestal. The top of the grout pedestal should be level with the jam nuts.

Step 2: Align the bolt holes in the mounting plate (attached to the bottom of the receiver) with the anchor bolts and lower the mounting plate onto the leveling (jam) nuts. Install $\frac{7}{8}$ " lock nuts on the anchor bolts but do not tighten them. Plumb the levelness of the receiver in 90° increments. Adjust the leveling nuts to fine tune levelness. Once the receiver is level, tighten the lock nuts against the top of the mounting plate.

Step 3: Assemble the crane by following the instructions in [ASSEMBLING THE CRANE](#) on p. 6.

Overhead view of foundation

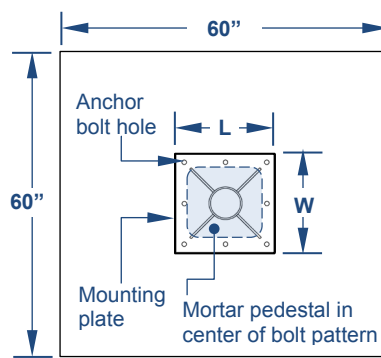

Model	L
WTJ-4	$10\frac{5}{8}$ "
WTJ-4-G	11"
WTJ-4-SS	11"

Model	W
WTJ-4	$10\frac{5}{8}$ "
WTJ-4-G	11"
WTJ-4-SS	11"

INSTALLING THE CRANE ON A VEHICLE

NOTE: Installation requires at least 2 people.

Step 1: Contact the vehicle manufacturer to determine the appropriate place to install the crane as well as the hardware necessary to fasten the crane to the vehicle. Bolt holes in the mounting plate are for $\frac{1}{2}$ " bolts. When choosing an installation site, consider the following factors:

- The vehicle must be able to support the combined weight of the crane + load weighing 125% of the capacity (1,000 lb. x 1.25 = 1,250 lb.).
- The installation location must also be able to withstand the dynamic forces exerted on it by the crane when the vehicle is in motion.
- The boom should be able to rotate freely when raised, i.e. without running into the sides of the vehicle.

Step 2: Review crane dimensions diagrammed on page 2 before selecting an installation location. Place the receiver in the location where it will be installed. Mark the locations of the bolt holes on the vehicle surface by using the mounting plate as a template. Drill a $\frac{9}{16}$ " hole at each mark.

Step 3: Align the mounting plate with the holes drilled in step 2. Person #1 should stabilize the crane while Person #2 fastens the mounting plate to the vehicle. Use only with the hardware and any backing or stiffeners recommended by the vehicle manufacturer.

Step 4: Assemble the crane following the instructions on p. 6.

CRANE FEATURES (SHOWN IN SHORT CONFIGURATION)

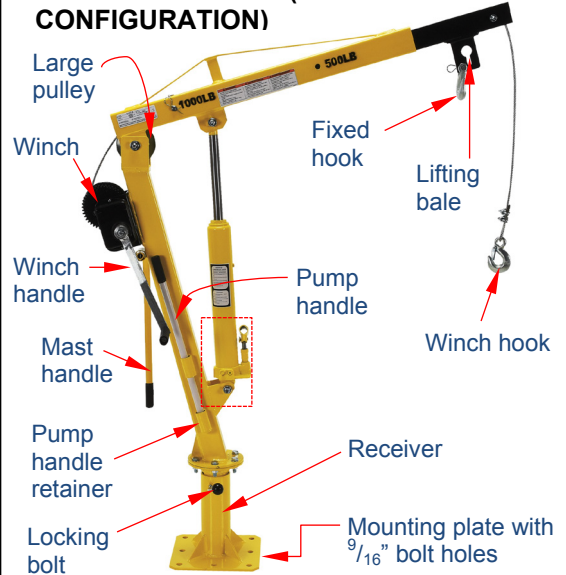

Operation of Relief Valve

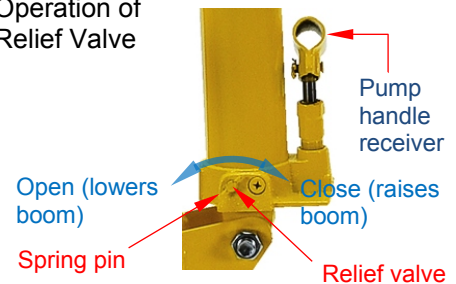

RAISING & LOWERING THE BOOM: Refer to “Crane features” & “Operation of Relief Valve” diagrams on [p. 8](#).

The crane includes a manual hydraulic pump to raise and lower the boom.

Raising the boom: Remove the pump handle from its holder. At one end of the handle is a (black) hand grip. Grasp the handle by the grip. At the other end of the handle are rectangular notches. Slide this end of the handle over the relief valve. The spring pin will seat into the notches. Turn the relief valve clockwise (to the right) until tight. Now the relief valve is closed. Once the valve is closed, insert the handle into the pump receiver. Move the handle up-and-down. The pump piston extends with each stroke of the handle and raises the boom.

Lowering the boom: Rotate the relief valve counterclockwise (to the left) with the end of the handle. This opens the valve. When the valve opens, the piston retracts and the boom lowers. The boom lowers more rapidly the more the valve is turned. To slowly lower the boom, carefully turn the valve counterclockwise until the boom begins to lower. To increase lowering speed, turn the valve farther.

BOOM LENGTH ADJUSTMENTS

The telescoping boom can be fastened/pinned in 2 locations (A & B on [p. 3](#) or [p. 5](#)). When pinned at point A, the boom is short and lifting capacity of the lifting bale is 1,000 pounds (454kg). When pinned at point B, the boom is extended/long and lifting capacity of the lifting bale is 500 pounds (227kg). **Capacities of the winch hook and the fixed hook are always 500 lb. (227kg) regardless of whether the boom is short or long.** To adjust boom length:

1. Use the pump to make the boom horizontal/level.
2. Remove the bolt and fasteners (or hitch pin and clevis pin).
3. Grasp the end of the telescoping boom. Move it until the holes align with the holes at either point A or point B.
4. Reinstall the bolt and fasteners (or clevis pin and the hitch pin).

USING THE CRANE

1. Apply appropriate rigging to the load.
2. Adjust the length of the boom as your application requires. Make sure that the load does not exceed the capacity for the selected boom length. See [SPECIFICATIONS](#) on p. 2.
3. Loosen the locking bolt to allow the turntable to rotate.
4. Grasp the mast handle and adjust the position of the crane. To avoid/minimize load swing when lifting a load:
 - a. **Lifting with the winch hook:** the load center of gravity should be directly beneath the center of the small pulley.
 - b. **Lifting with the fixed hook:** the load center should be directly beneath the shackle pin.
 - c. **Lifting bale:** Attach rigging (e.g. chain and hook) to the lifting bale. All rigging must be rated for at least 1,000 lb. (454kg). Load center should be directly below the point where the rigging attaches to the bale.

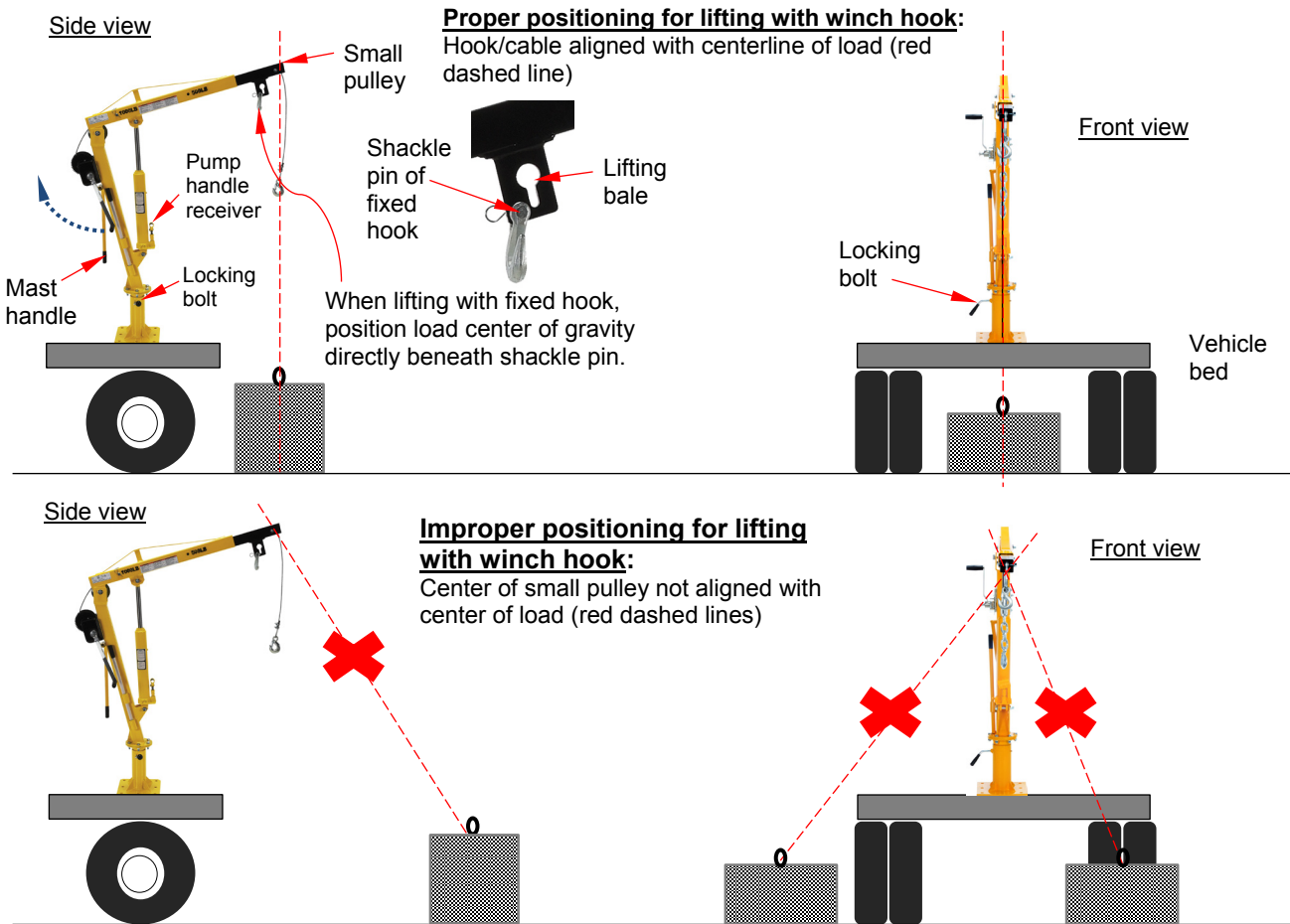

5. Attach the load rigging to the selected hook.
 - a. Fixed hook OR lifting bale: Lower the boom sufficiently to attach it to the load rigging.
 - b. Winch hook: Turn the winch handle counterclockwise until the hook is low enough to attach the rigging.
6. Tighten the locking bolt tightly against the turntable. Turn the winch handle clockwise to raise the load just above the vehicle bed/floor.
7. Loosen the locking bolt. Rotate the boom slowly and direct the load to the desired location. Lower the load until it is entirely supported by the vehicle.
8. Put the crane into transport configuration--short boom with boom fully lowered.
 - a. Pin the booms together at point A (short configuration).
 - b. Use the pump handle to turn the relief valve counterclockwise. Lower the boom completely to relieve hydraulic pressure.

RECORD OF SATISFACTORY CONDITION

After assembling the unit and before using it for the first time, make a written record that describes the appearance and operation of each part. Pay particular attention to junctions (areas where sections bolt together) and pivot points. Turn the winch handle to raise and lower the winch hook. Record your observations about how the unit looks and sounds as the hook rises and lowers. Measure the throat opening of both hooks and record the measurements. Use the pump to raise and lower the boom. Describe how the cylinder extends and retracts, the sound of the pump as it operates, and the force required to move the handle back-and-forth. Collect all photos and writings in a file. This file is a record of the crane in satisfactory condition. During future inspections, compare your observations with the recorded information to determine whether a component is in normal condition or requires repair or replacement.

INSPECTIONS

Inspect and maintain the unit as described (below). If problems are discovered during an inspection, restore the unit to satisfactory condition before returning it to service. If the unit cannot be restored to satisfactory condition, permanently remove the crane from service.

The unit must be tested at 125% of its rated capacity anytime the crane is repaired. Put the boom in short configuration (see [pages 2](#) and [3](#) or [5](#)) and lift a 1,250 lb. test load with the lifting bale using appropriate rigging.

At least once per month inspect:

1. Winch and pulleys: raise and lower the winch hook. Confirm that the cable smoothly winds off of and onto the winch spool. The winch should lock automatically whenever the handle is not rotating. This automatic locking feature prevents the hook from lowering on its own. The large and small pulleys should not be loose or severely worn and should rotate freely as the cable passes over them.
2. Winch cable: check for reeving, fraying, thinning, bird-caging, and elongating regions. If the cable is damaged, replace it.
3. Frame elements and hardware:
 - a. Frame elements: examine the mast receiver, turntable, mast, boom, and telescoping boom for damage, deformation, corrosion, cracked welds, and severe wear. Inspect pivot points for severe wear. All frame members should be square, rigid, and free of significant rusting and corrosion. Remove rust with steel wool or a metal bristle brush and apply touchup paint to the affected areas.
 - b. Fasteners: inspect all bolts, pins, washers, nuts, etc. Tighten loose connections.
4. Mast bearing: Rotate the boom in both directions. Make sure that it rotates smoothly. Listen for unusual noises. If the crane wobbles or is unusually noisy as it rotates, remove the mast and grease the bearing at the bottom. If lubrication does not resolve the problem, the bearing might need to be replaced. Contact the factory to discuss the problem.
5. Hooks and bale: Visually inspect both hooks and the bale. Look for deformations and cracks. Immediately discard a hook if it is cracked or if the throat opening is more than 15% in excess of the original throat opening. Discard a hook if it is twisted more than 10° from the plane of the hook. Confirm normal operation and operation of the safety latch of both hooks.
6. Vehicle: inspect the vehicle where the crane is mounted. Closely examine the area around the mounting plate. Look for rust, corrosion, and metal fatigue. Check the mounting plate (base of the mast), the anchoring hardware, and the vehicle bed/floor, particularly around the anchor bolts. Make sure that the receiver is securely anchored (i.e. does not wobble). Confirm that anchoring hardware is in normal condition.
7. Labels: confirm that all labels are in good condition and in place as shown in the [LABELING DIAGRAM](#) on p. 11.

Every 6 months:

Conduct a load test. Lift a test weight with the lifting bale equal to 125% of the capacity. After the test, examine the crane and the vehicle bed where the crane is mounted. Look for deformations, cracks, and metal fatigue. Do not continue to use the crane unless both it and the supporting vehicle (or surface) are in satisfactory condition.

TROUBLESHOOTING

Always unload the crane and disconnect the winch from the power supply before troubleshooting an issue.

Problem	Possible causes	Solutions
1) Cable jumps or lurches as the winch operates	a. Poor spooling on winch reel/drum b. Kink in cable	a. Spool out the cable and inspect it for kinks, etc. Respool cable onto winch reel. Replace cable if damaged. b. Replace cable if kinks cannot be straightened.
2) Mast does not rotate without great effort	c. Locking bolt tightened. d. Bearing overly worn.	c. Loosen bolt. d. Remove mast from mast receiver. Inspect bearing. Replace bearing if severely worn.

LABELING DIAGRAM

Label content and locations are subject to change so your product might not be labeled exactly as shown. Compare this diagram to the [RECORD](#). If differences exist between the diagram and the [RECORD](#), contact [TECHNICAL SERVICE](#). Replace all labels that are damaged, missing, or not easily readable (e.g. faded). To order replacement labels, contact the technical service and parts department online at http://www.vestilmfg.com/parts_info.htm. Alternatively, you may request replacement parts and/or service by calling (260) 665-7586 and asking the operator to connect you to the [PARTS DEPARTMENT](#).

A: Label 586

▲ WARNING	▲ ADVERTENCIA	▲ AVERTISSEMENT
<ul style="list-style-type: none"> • DO NOT exceed rated capacity • LOWER LOAD before moving to avoid load swing • NEVER STAND under, beside or in front of load • USE on hard level surface • INSPECT connectors before using • READ manual before use 	<ul style="list-style-type: none"> • No exceda la capacidad tasada • Descienda la carga antes de mover para evitar que la carga se balancee • Nunca se situe debajo, al lado o delante de la carga • Use en una superficie a nivel dura • Inspeccione las conexiones antes del uso • Lea el manual antes del uso 	<ul style="list-style-type: none"> • NE PAS DÉPASSER la capacité nominale • DESCENDRE la charge avant de la transporter pour éviter la réaction • JAMAIS vous mettre sous, à côté de ou devant une charge • UTILISER sur un sol plat et dur • INSPECTER les connexions avant utilisation • LIRE le guide avant utilisation

B: Label 1153

MODEL / MODÉLO / MODÈLE	_____
WEIGHT / PESO / MASS	_____
CAPACITY / CAPACIDAD / CAPACITÉ	_____
SERIAL / SERIE / SÉRIE	_____
UNITS: 2.2 lb. = 1kg 1" (or 1in.) = 2.54cm	1193

C: Label 1045

Hydraulic jack operation & maintenance instructions:

- Raising the boom: Close release valve by turning valve lever clockwise until tight. Move jack handle back-and-forth.
- Lowering the boom: Boom lowering speed is controlled by the release valve. Slowly open release valve by turning valve lever counterclockwise. The more open the valve is the faster the boom descends.
- Adding and replacing oil: Only use anti-wear hydraulic fluid, viscosity grade of 150 SUS at 100°F (ISO 32 @ 40°C) such as AW-32 or Dexron transmission fluid. Add oil up to fill plug. Replace oil if it looks milky (water present).

WARNING

Improper or careless use of this crane might result in serious personal injuries.

- Do not exceed capacity.
- Only use this crane to lift loads. Do not pull or drag items with crane.
- Do not leave suspended loads unattended. Return load to ground or support load with appropriately rated stands/blocking before leaving load unattended.
- Inspect rigging before lifting load. Rigging capacity must be at least equal to crane capacity.
- (WTJ-series cranes) Before moving vehicle:
 - ◊ Boom must be lowered (open release valve to relieve hydraulic pressure), AND
 - ◊ Mast must not be able to rotate. Firmly tighten mast set screw (screw with black knob) against mast to prevent rotation.

D: Label 1038

Tighten knob before moving vehicle
Apriete la perilla antes de vehiculo móvil
Resserrer le bouton avant de déplacer véhicule

E: Winch system capacity label (not shown)
 NOTE: Winch system capacity is always 500 lb. regardless of boom configuration.

F: Label of capacities of lifting attachment points (not shown)
 NOTE: The capacity of the winch system is always 500 lb. regardless of boom configuration. Fixed hook capacity is also 500 pounds regardless of boom configuration.

LIMITED WARRANTY



Vestil Manufacturing Corporation (“Vestil”) warrants this product to be free of defects in material and workmanship during the warranty period. Our warranty obligation is to provide a replacement for a defective, original part covered by the warranty after we receive a proper request from the Warrantee (you) for warranty service.

Who may request service?

Only a warrantee may request service. You are a warrantee if you purchased the product from Vestil or from an authorized distributor AND Vestil has been fully paid.

Definition of “original part”?

An original part is a part used to make the product as shipped to the Warrantee.

What is a “proper request”?

A request for warranty service is proper if Vestil receives: 1) a photocopy of the Customer Invoice that displays the shipping date; AND 2) a written request for warranty service including your name and phone number. Send requests by one of the following methods:

US Mail

Vestil Manufacturing Corporation
2999 North Wayne Street, PO Box 507
Angola, IN 46703

Fax

(260) 665-1339
Phone
(260) 665-7586

Email

info@vestil.com
Enter “Warranty service request”
in subject field.

In the written request, list the parts believed to be defective and include the address where replacements should be delivered. After Vestil receives your request for warranty service, an authorized representative will contact you to determine whether your claim is covered by the warranty. Before providing warranty service, Vestil will require you to send the entire product, or just the defective part (or parts), to its facility in Angola, IN.

What is covered under the warranty?

The warranty covers defects in the following original, dynamic parts: motors, hydraulic pumps, motor controllers, and cylinders. It also covers defects in original parts that wear under normal usage conditions (“wearing parts”), such as bearings, hoses, wheels, seals, brushes, and batteries.

How long is the warranty period?

The warranty period for original dynamic components is 90 days. For wearing parts, the warranty period is 90 days. Both warranty periods begin on the date Vestil ships the product to the Warrantee. If the product was purchased from an authorized distributor, the periods begin when the distributor ships the product. Vestil may, at its sole discretion, extend a warranty period for products shipped from authorized distributors by up to 30 days to account for shipping time.

If a defective part is covered by the warranty, what will Vestil do to correct the problem?

Vestil will provide an appropriate replacement for any *covered* part. An authorized representative of Vestil will contact you to discuss your claim.

What is not covered by the warranty?

The Warrantee (you) are responsible for paying labor costs and freight costs to return the product to Vestil for warranty service.

Events that automatically void this Limited Warranty.

- Misuse;
- Negligent assembly, installation, operation or repair;
- Installation/use in corrosive environments;
- Inadequate or improper maintenance;
- Damage sustained during shipping;
- Collisions or other accidents that damage the product;
- Unauthorized modifications: Do not modify the product IN ANY WAY without first receiving written authorization from Vestil.

Do any other warranties apply to the product?

Vestil Manufacturing Corp. makes no other express warranties. All implied warranties are disclaimed to the extent allowed by law. Any implied warranty not disclaimed is limited in scope to the terms of this Limited Warranty. Vestil makes no warranty or representation that this product complies with any state or local design, performance, or safety code or standard. Noncompliance with any such code or standard is not a defect in material or workmanship.