

# REV02082024



## ELECTRIC STATIONARY AIR COMPRESSOR

MODEL#(s):	NES05V060V1	5896641
	NES07V080Y1	5899625
	NES10V080V1	5899617
MOTOR:	230V (+ or - 10%) ~ 60Hz, 1 Phase	
PUMP:	5HP	APP2V0518S
	7.5HP	APP3Y0732TR2
	10HP	APP4V1043TR2
NO LOAD MOTOR SPEED:	1750 RPM	
TANK OUTLET SIZE:	3/4" NPT FEMALE	
AIR DELIVERY @100PSI:	5HP	19CFM
	7.5HP	26CFM
	10HP	38CFM

## Owner's Manual



**5896641**  
**NES05V060V1**

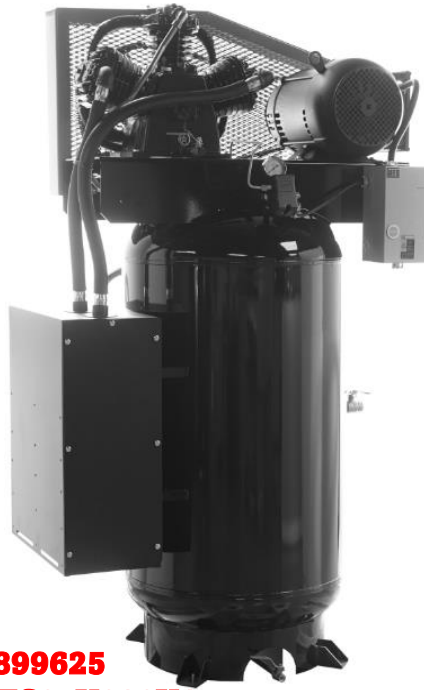

**5899625**  
**NES07V080Y1**

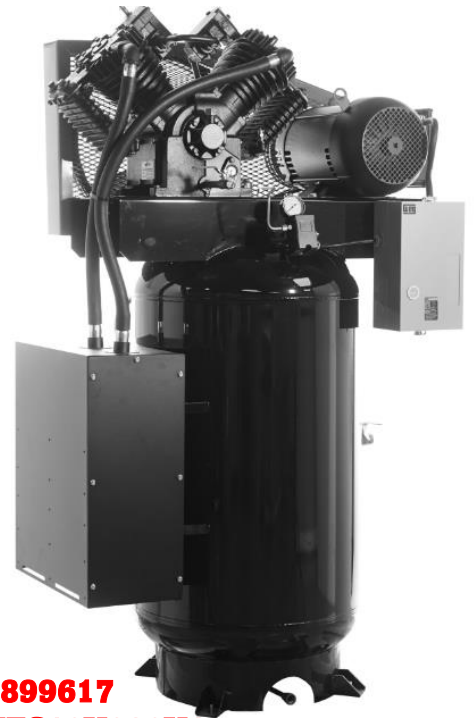

**5899617**  
**NES10V080V1**

North Star electric, stationary, belt-driven compressors has a 1-stage, 2-cylinder pump (Model 5896641), a 2-stage 3-cylinder pump (Model 5899625), or a 2-stage 4-cylinder pump (Model 5899617)

**Limited Warranty**

Dear Valued Customer:

The NorthStar Product you just purchased is built with the finest material and craftsmanship. Use this product properly and enjoy the benefits from its high performance. By purchasing a NorthStar product, you show a desire for quality and durability. Like all mechanical equipment this unit requires a due amount of care. Treat this unit like the high quality piece of machinery it is. Neglect and improper handling may impair its performance. Please thoroughly read the instructions and understand the operation before using your product. Always contact NorthStar Product Support at 1-800-270-0810 prior to having any service or warranty work performed, as some services performed by parties other than NorthStar approved service centers may void this warranty. This warranty is in lieu of any other warranty expressed or implied and NorthStar assumes no other responsibility or liability outside that expressed within this warranty.

**Limited Warranty**

NorthStar shall warranty any piece of equipment manufactured, or parts of equipment manufactured, to be free from defects in material or workmanship for a period of:

NorthStar Warranty		
Item #	Consumer Warranty Period	Commercial Warranty Period
5896641	4 years from date of purchase by user	2 years from date of purchase by user
5899625		
5899617		

“Consumer use” means personal residential household use by a consumer. “Commercial use” means all other uses, including use for commercial, income producing or rental purposes or when purchased by a business.

This warranty applies to the original purchaser of the equipment (verification of purchase, in the form of a receipt, is the responsibility of the buyer), is non-transferable, and covers parts and labor. Parts will be replaced or repaired at no charge, except when the equipment has failed due to lack of proper maintenance. If a part is no longer available, the part may be replaced with a similar part of equal function. Any misuse, abuse, alteration or improper installation or operations will void warranty. Determining whether a part is to be replaced or repaired is the sole decision of NorthStar. NorthStar will not provide for replacement of complete products due to defective parts. Any costs incurred due to replacement or repair of items outside of a NorthStar approved facility is the responsibility of the buyer and not covered under warranty. Transportation costs to and from service center is the responsibility of the customer.

In addition to the normal warranty, NorthStar shall warrant any normal wear item from defects in material or workmanship for a period of 90 days from the date of purchase by user. Normal wear items include, but are not limited to, belts and filter elements.

This warranty specifically excludes the following; failure of parts due to damage caused by accident, fire, flood, windstorm, acts of God, applications not approved by NorthStar in writing, corrosion caused by chemicals, use of replacement parts which do not conform to manufacturer’s specifications, damage related to rodent and/or insect infestation and damage caused by vandalism. Additional exclusions: loss of running time, inconvenience, loss of income, or loss of use, including any implied warranty of merchantability of fitness for a specific use. Also, Power Equipment needs periodic parts and service to perform well, and this warranty does not cover instances when normal use has exhausted the life of a component or the motor.

This warranty does not cover any personal injury or damage to surrounding property caused by failure of any part. Repair or replacement of parts does not extend the warranty period.

Please fill in the following information and have it on hand when you call in:

Customer Number: \_\_\_\_\_

Date of Purchase: \_\_\_\_\_

NorthStar Serial Number: \_\_\_\_\_

Item Number: \_\_\_\_\_

## CONTENTS

Warranty Statement	2
Safety Information	4
Breathable Air	5
Pressurized Components	5
Personal Protective Equipment	5
Nomenclature	6
Installation	7-13
Installation Area	7
Lifting and Movement	8
General Lifting	8
Anchoring	9
Electrical	10-11
Piping	12-13
Pre-use Inspection	14
Operation	15
Maintenance	15-16
Maintenance Schedule	15
Oil Change/Selection	16
Oil Disposal	16
FAQ and Troubleshooting	17
Pump Break Down	19-26

**▲ WARNING:** This product can expose you to soots, tars, and mineral oils (untreated and mildly treated oils and used engine oils), which are known to the State of California to cause cancer.

For more information go to [www.P65Warnings.ca.gov](http://www.P65Warnings.ca.gov).

## SAFTEY INFORMATION

This manual contains very important information to know and understand. This is to provide for SAFTEY and to PREVENT EQUIPMENT PROBLEMS. To help understand this information, observe the following:

- DANGER:** Danger indicates and imminently hazardous situation which, if not avoided, will result in death or serious injury.
- WARNING:** Warning indicates a potentially hazardous situation which if not avoided, could result in death or serious injury.
- CAUTION:** Caution indicates a potentially hazardous situation which, if not avoided, may result in minor or moderate injury.
- NOTICE:** Notice indicates important information, that if not followed, may cause damage to equipment.

### CALIFORNIA PROPOSITION 65

**WARNING:** This product or its power cord may contain chemicals known to the state of California to cause cancer and birth defects or other reproductive harm. Wash hands after handling.

1. Allow only trained, authorized persons who have read and understood these operating instructions to use this equipment. Failure to follow the instructions, procedures and safety precautions in this manual can result in accidents and injuries.
2. NEVER start or operate the compressor under unsafe conditions. Tag the compressor, disconnect, and lock out all power to it to prevent accidental start-up until the condition is corrected.
3. Install, use, and operate the compressor only in full compliance with all pertinent OSHA regulations and all applicable Federal, State & Local codes, standards, and regulations.
4. NEVER modify the compressor and/or controls in any way.
5. Keep a first aid kit in a convenient place. Seek medical assistance promptly in case of injury. Avoid infection by caring for any small cuts and burns promptly.



## Breathable Air

1. **NEVER** use air from this compressor for breathable air except in full compliance with OSHA Standards 29 CFR 1910 and any other Federal, State or Local codes or regulations.
2. **DO NOT** use airline anti-icer systems in air lines supplying respirators or other equipment used to produce breathable air. **DO NOT** discharge air from these systems in unventilated or other confined areas.



***DANGER: Death or serious injury can result from inhaling compressed air without using proper safety equipment. See OSHA standards on safety.***

## Pressurized Components

This equipment is supplied with an ASME designed and rated pressure vessel protected by an ASME rated relief valve. Pull the ring before each use to ensure the valve is functional. **DO NOT** attempt to open the valve while the machine is under pressure. See figure on the right.

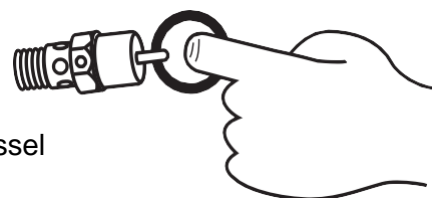

***CAUTION: DO NOT PULL WITH PRESSURE IN SYSTEM***

## Personal Protective Equipment

Be sure all operators and others around the compressor and its controls comply with all applicable OSHA, Federal, State and Local regulations, codes, and standards relating to personal protective equipment. This includes respiratory protective equipment, protection for the extremities, protective clothing, protective shields and barriers, electrical protective equipment, and personal hearing protective equipment.

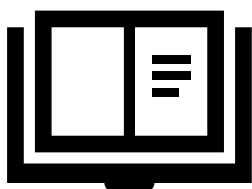

***Read all manuals and information supplied for this unit carefully. Be thoroughly familiar with all inspection and operation guidelines. Only persons that have read and understand this manual should operate the compressor.***



***DANGER: Failure to follow instructions and safety guidelines laid out in this manual can result in serious injury or death. Ensure all users of this product read and understand this manual. Store the manual near the compressor for ease of reference. If the manual becomes damaged or illegible contact the manufacturer for a replacement.***

**NOMENCLATURE**



1. TANK DRAIN: 5-7.5HP: VALVE001, 10HP: DRAIN013	2. QUIET ARMOR SYSTEM	3. OIL SIGHT GLASS: (SEE PUMP SPECIFIC DIAGRAM)	4. OIL DRAIN: 5-7.5 HP: FITTING076+FITTING077, 10HP: VALVE002
5. AIR INTAKE HOSE: HOSE002	6. COMPRESSOR PUMP: 5HP: APP2V0518S, 7.5HP: APP3Y0732TR2, 10HP: APP4V1043TR2	7. SAFETY POP OFF: VALVE008	8. PUMP BREATHER: BREATHER006
9. BELT GUARD: 5HP: GUARD006G01ARD, 7.5HP: GUARD002G02ARD, 10HP: GUARD002G01ARD	10. PUMP MAIN LINE: 5HP: TUBING003G01, 7.5HP: TUBING003G11, 10HP: TUBING003G01A	11. ELECTRIC MOTOR: 5HP: MOTOR005-4, 7HP: MOTOR007HPWG, 10HP: MOTOR010HPWG	12. CAPACITOR BOX
13. MOTOR POWER WIRE: 5HP: WIREHARN007, 7.5+10HP: WIREHARN005	14. MAGNETIC STARTER: 7.5HP: STARTER035, 10HP STARTER036	15. SWITCH ASSEMBLY	16. TANK OUTLET: VALVE010
17. ASME STORAGE TANK: 5HP 60 GALLON VERTICAL, 7.5+10HP: 80 GALLON VERTICAL	18. GUARD BRACE: 5HP: GUARDBRACE002, 7.5HP +10HP GUARDBRACE001	19. TANK CHECK VALVE: 5+7.5HP: VALVE204, 10HP: VALVE004	20. GUARD TRAY: 5HP: TRAY006, 7.5+10HP: TRAY002A
21. AIR RELEASE LINE: 5HP: TUBING001G01, 7.5HP+10HP TUBING001G03	22. PRESSURE GAUGE: GAUGE011	23. PRESSURE SWITCH: 5HP: SWITCH001, 7.5+10HP SWITCH036	24. AUTO/OFF SWITCH

## INSTALLATION

### Area

1. Install compressor in a clean, dry, and well-lit area. Be sure installation area can maintain a temperature range between 35° - 110° F.



**CAUTION: If ambient temperature drops below 32°F, be sure to protect safety/relief valves and drain valves from freezing. NEVER operate compressor with temperatures below 15°F or above 125°F.**

2. Allow sufficient space around the compressor for maintenance access and adequate airflow. Mount unit with the belt guard (pulley and flywheel) side to the wall and leave a minimum of 15 inches of clearance.
3. If acid is used in operating environment or air is dust laden, pipe intake to outside fresh air. Increase pipe size by 1/8" for every 20ft of run. Be sure to install a protective hood at the outside air intake location to prevent debris and foreign objects from blocking the intake pipe.
4. In operating environments where excessive water, oil, dirt, acid, or alkaline fumes are present, a TEFC (totally enclosed, fan cooled) motor is highly recommended. Check nameplates for motor type.
5. Insulate cold water or other low temperature pipes that pass overhead to avoid condensation dripping on the compressor.
6. In environments where fine dust is common such as granite, marble, or concrete plants the unit must be installed in a separate room with its own dedicated ventilation system.

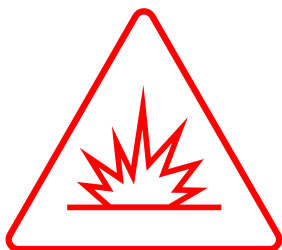

**DANGER! DO NOT install compressor in boiler room, paint spray room, or area where sandblasting occurs. Make sure inlet air is away from exhaust fumes or other toxic, noxious, or corrosive fumes or substances.**

7. The unit can be stored outside under the following guidelines: It must be in a covered area out of extreme weather with no ability for moisture to get to the unit, it is also highly recommended that the unit is out of direct sunlight as it can fade and/or damage the coating on the unit. Direct sunlight may also interfere with safety decals on the unit.
8. If the unit is in an enclosed space, it requires proper ventilation as the ambient air temp where the compressor is located CANNOT exceed 115 degrees F.
9. Use shims to level the compressor if installation area is not flat. This will help prevent excessive vibration and premature pump wear.

## Lifting and Movement/Forklift

1. Make sure lift operator stays aware while moving the compressor.
2. Be sure to uncrate the compressor prior to movement. This will allow a visual reference for the balance of the unit.
3. Be sure the load is secure and well balanced before moving the compressor.
4. Make sure the forks are fully engaged and level prior to lifting or moving the unit.
5. Keep the unit/load as low as possible while moving and refrain from quick changes in direction.
6. For all other forklift safety standards/regulations please reference OSHA 1910.178- Powered industrial trucks.

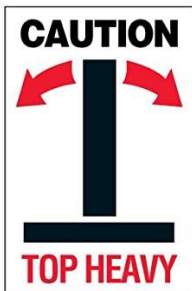

***CAUTION: Compressors, especially vertical units, are exceptionally top heavy. Take care when moving and do not make fast or sudden moves during transport.***



## General Lifting Information

1. Carefully inspect all lifting equipment and ensure it is in good condition. Rated capacity of lifting equipment must exceed compressor weight. **NEVER** lift with under sized or damaged equipment.
2. If using lifting equipment, ensure all lifting points are in good condition and tighten any loose nuts or bolts before lifting.
3. A sling **MUST** be used when moving the compressor with a helicopter or other airborne equipment. Be sure to follow OSHA standards 1910 subpart N.
4. Use guide ropes or equivalent to prevent twisting or swinging of the compressor while it is in the air and **NEVER** attempt to lift the unit in high winds. Keep compressor as low to the ground as possible.
5. Keep all persons away from the compressor when it is lifted. **DO NOT** allow persons under the compressor while it is being lifted.
6. **DO NOT** use bolts or other hooks on individual components to move the compressor.
7. When moving and or placing the compressor ensure it is on/across a surface that can hold the combined weight of the compressor and the loading equipment.



***WARNING: Do NOT operate the unit if damaged during shipping, handling or use. Damage may result in bursting and may cause injury to persons or property damage. If the unit is received with damage, please contact customer support as soon as possible.***

## Anchoring

To ensure proper and safe operation of the compressor the unit is required to be anchored to a flat, smooth, concrete floor. Compressors are also required to be on ¼ inch (6.35mm) **MAXIMUM** thick rubber anti-vibration pads.

Recommended anchor Bolt specifications: wedge anchors; 3/8 in width by 3.5 in length.

### How to Anchor the Compressor

1. Make sure the compressor is in the desired location and the anti-vibration pads are under the feet of the compressor.
2. Using the holes in the feet as guides, drill the holes for the anchor bolts through the vibration pads and into the concrete.

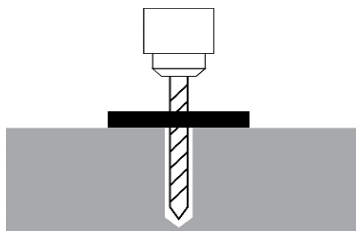

Go in straight; do not let the drill wobble.  
Use a carbide bit (conforming to ANSI B212.15).  
The diameter of the drill bit **must** be the same as the diameter of the anchor bolt. If you are using a 3/8-inch diameter anchor bolt, for example, use a 3/8 inch diameter drill bit.

3. Thoroughly clean each hole.

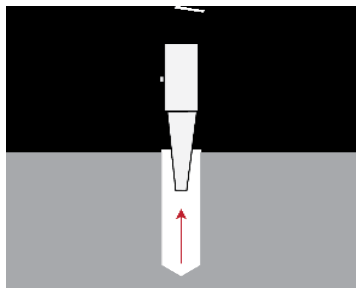

If a vacuum is not available, use a wire brush, hand pump, or compressed air.

**DO NOT** ream the hole. **DO NOT** make the hole any wider than the drill bit made it.

4. Put the Washer and Nut into place, make sure the top of the Nut is flush with the top of the anchor bolt, then insert the anchor bolt into the hole.
5. Hammer or mallet the anchor bolt down into the hole.

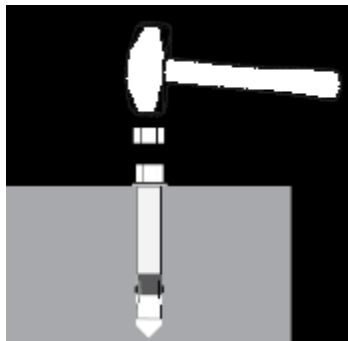

Stop hammering when the washer is snug against the top of the foot.

6. Tighten each nut clockwise, **DO NOT** over tighten. **DO NOT** use an impact to tighten the anchors.

**Electrical Safety**

1. Follow all NEC and local codes for electrical wiring. Allow only authorized service personnel or certified electricians to install electrical components.
2. Put unit on a dedicated circuit and make sure no other electrical equipment is wired into it. Failure to wire unit on an independent circuit can cause circuit overload and/or imbalance in motor phasing. Install proper No Fuse Breaker (NFB) according to the chart listed below. You may also reference NEC and local codes for additional support.
3. Ensure incoming service has adequate ampere rating.
4. Do not use mixed wire sizes when wiring the unit.
5. The unit must be properly grounded. **DO NOT** connect ground to air or cooling lines.



***DANGER: Be sure only trained and authorized personnel install and maintain this compressor in accordance with all applicable federal, local, and state codes, standards, and regulations. Follow all NEC (National Electric Code) standards especially those concerning equipment grounding conductors.***

***DANGER: Improperly grounded electrical components are shock hazards. Make sure all components are properly grounded to prevent death or serious injury.***

**Wiring the Compressor**



***All electrical work must be done by a licensed, certified Electrician in accordance with all applicable local electrical codes. Damage caused by improper electrical installation may void your warranty.***



***WARNING: When wiring units with magnetic starters, DO NOT install power directly to the pressure switch. This can cause fire and possible injury/property damage.***

**Wire and Breaker Requirements**

1. Voltage should not vary more than 10% to ensure proper operation of the compressor.
2. Wire size and breaker requirements for single phase units:\*\*

Motor Horsepower	Breaker Size (Amps)	Wire Size (50ft or less)*	Wire Size (More than 50ft)	Peak Start Amps (Locked Rotor)
5	40	8 gauge	Consult Electrician	135
7.5	50	6 gauge	Consult Electrician	210
10	60***	4 gauge	Consult Electrician	265

\*Wire size distances are from unit to the panel where the breaker is housed.

\*\*CAUTION: Under sizing wires and/or breakers can cause damage to the unit, possible injury to personnel, and void your warranty.

\*\*\*Installation of 10HP unit on panels smaller than 200 AMPS may result in the compressor not functioning correctly and/or damaging the compressor or property

3. WIRING 7.5HP AND 10HP SINGLE PHASE:

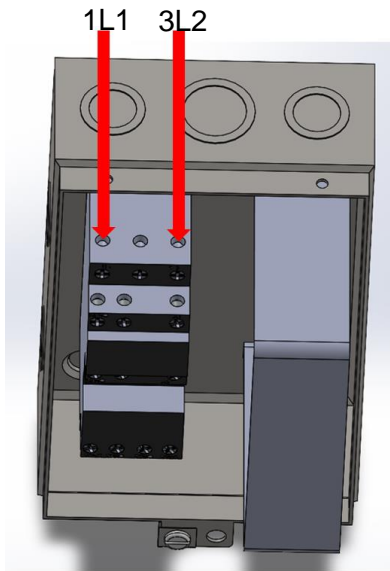

**INCOMING POWER IS TO BE WIRED TO THE FOLLOWING TERMINALS:**

**1L1 AND 3L2**

1L1 WILL HAVE AN ADDITIONAL WHITE WIRE

3L2 WILL HAVE AN ADDITIONAL RED WIRE.

THE ADDITIONAL WIRES ARE REQUIRED FOR OPERATION DO NOT REMOVE OR MODIFY.

4. WIRING 5HP SINGLE PHASE

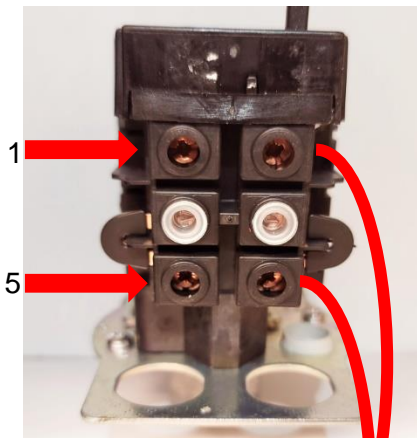

**INCOMING POWER IS TO BE WIRED TO THE FOLLOWING TERMINALS:**

**1 AND 5**

**Piping (Safety steps)**

1. Install appropriate flow-limiting valves as necessary according to pipe size(s) used and run lengths. This will reduce pressure in case of hose failure, per OSHA Standard 29 CFR 1926.302(b)(7).
2. Flow-limiting valve are listed by pipe size and rated CFM. Select appropriate valves according to manufacturer’s recommendations.
3. Use a **FLEXIBLE** connection between compressor tank and dryer/piping system to minimize noise, vibration, pump wear, and to prevent damage to the unit or piping system.
4. Install ASME code safety valves and ensure piping system is equipped with adequate condensate drains.

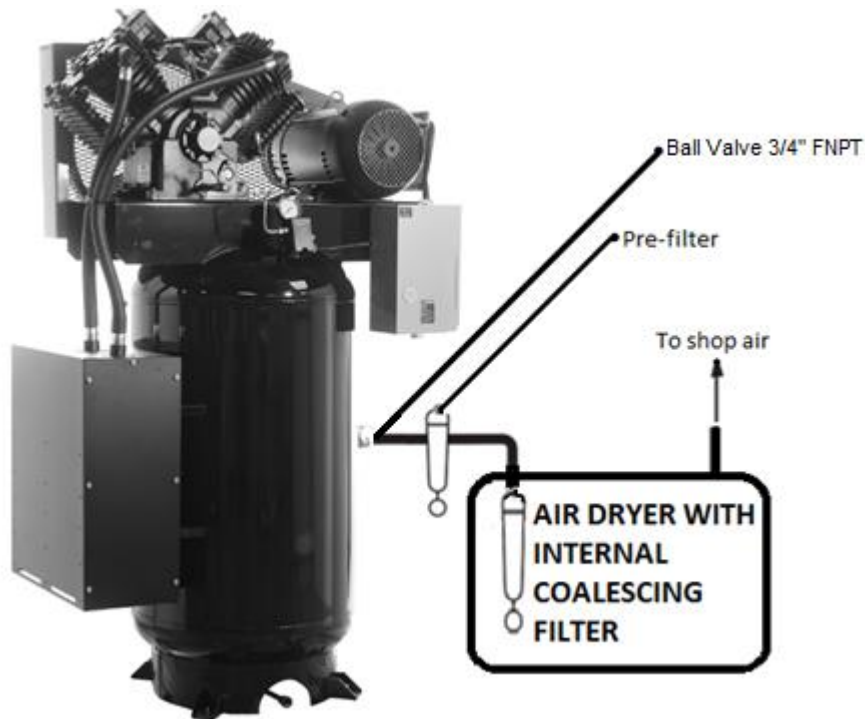

Typical stationary electric compressor set up. Internal coalescing filter may not be present in other brands.

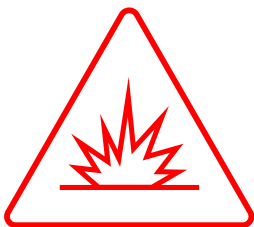

***DANGER: NEVER install a shut off valve such as a glove or gate valve between the pump discharge and the air tank unless an ASME rated safety valve rated for the correct pressure is installed in the line between the valve and the compressor pump.***

1. Minimum pipe size for compressed air lines: (Pipe sizes are shown in inches)

CFM	25ft	50ft	100ft	250ft
20	3/4	3/4	3/4	1
40	3/4	3/4	1	1
60	3/4	1	1	1
100	1	1	1	1 – 1/4
125	1 – 1/4	1 1/2	1 – 1/4	1 – 1/2

- 2. Air systems should be checked daily for leaks. This helps to prevent unnecessary load on the compressor and helps increase energy savings.
- 3. Examples of air systems:

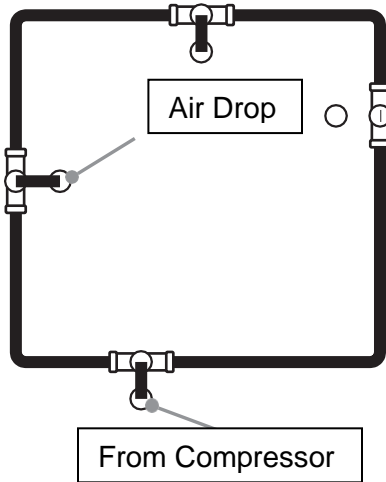

Closed loop system. Install tee fitting in piping from air to minimize pressure drop and to allow air flow in two directions.

Air Drop: Install tee fitting with branch to top to minimize condensation.

Elevation View

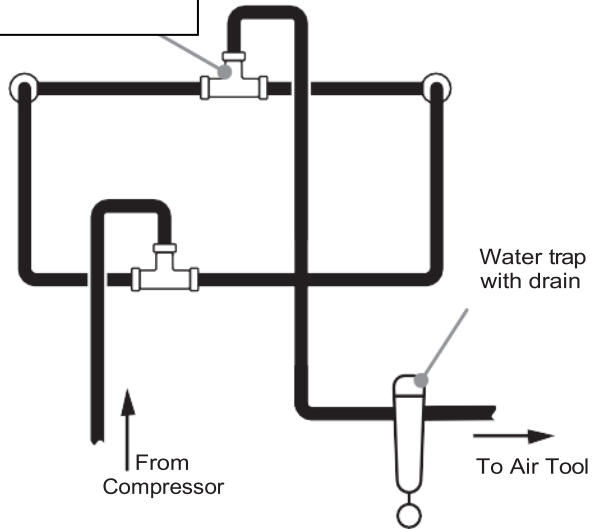

- 4. Make sure any tube, pipe, fitting, or hose connected to the unit can withstand operating temperatures and retain pressure.
- 5. Never use reducers in discharge piping. Keep all piping and fittings the same size in the piping system.



**WARNING: Never use plastic (PVC) pipe for compressed air. Serious injury or death could result. Piping MUST have a pressure rating of 200 PSI or greater.**

**PRE-USE INSPECTION**

1. The unit is shipped with pump break-in oil and should be ready to operate. Be sure to check for proper oil level before running the compressor. Break in oil should be changed after 70 Hours of operation (active pumping time). See maintenance section for more information on oil changes and frequency.

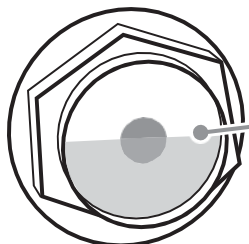

Oil level should be to the center of the red circle in the sight glass. Oil level WILL SLIGHTLY LOWER once the unit turns on and oil begins to circulate.

2. Check for proper belt tension. There should be ½ inch of belt slack/deflection. Refer to maintenance section if adjustment is necessary.
3. Inspect belts for frays or unit for an excess buildup of black rubber dust indicating belt wear.

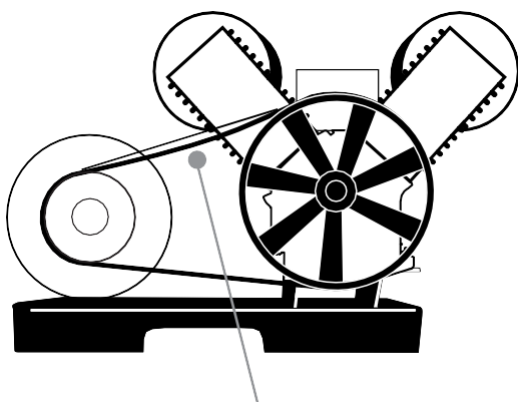

1/2" Deflection

Proper belt tension is determined by pressing midway between the motor pulley and the pump flywheel.

4. Check proper operation of all pop off safety valves on unit. Pull rings on valves to ensure they move and are free of any obstructions. **DO NOT** pull the safety valve on the tank if there is air in the tank!
5. Inspect all air lines/piping for proper for secure fit and corrosion or line degradation. **DO NOT** operate the compressor with damaged lines. **DO NOT** use damaged or cracked air lines as a rupture could result in damage/injury to personnel or property.
6. **WITH UNIT LOCKED OUT** (power off at source i.e. the electrical panel/disconnect) ensure all electrical wiring, including all terminals, are in good condition and are free of buildup, fraying, cracks or discoloration replace as needed. Check tightness of bolts securing wiring in place.
7. Ensure unit is secured in place and has not shifted. Verify anchor bolts are in place and are in good condition.
8. Remove any loose items from around/on compressor to avoid damage to the unit. Examples would be loose clothing items, rags, papers, bottles, or any item that may have been placed on the unit.
9. Check unit for any oil leaks. If leaks are found contact manufacturer for further instructions.
10. Unit should **NEVER** be operated without the belt guard in place.
11. Inspect Flywheel for cracks or missing fins. **NEVER** operate a unit with a damaged flywheel; serious injury or death could result. If you suspect your flywheel may have been damaged, contact technical assistance and **DO NOT** allow the machine to be operated.

## OPERATION

**Ensure all personnel that work around or operate the compressor have read this manual and are well versed in the operation of this machinery. NEVER allow untrained personnel to operate this unit.**

1. Once the inspection is completed, open your discharge port (outlet ball valve). This should already be connected to your shop airline system or dryer if installed.
2. Ensure all personnel are clear of the compressor and aware that it is being started.
3. Turn the selector on your pressure switch to AUTO. This will start your compressor and allow it to fill. The tank will fill to 150 PSI(5HP) OR 175 PSI (7.5+10HP), and unless otherwise noted, will shut off. The unit will begin pumping again once the tank is drained down to approximately 135 PSI.

## MAINTANENCE

**Compressor maintenance must be performed as described in the maintenance schedule, failure to do may lead to compressor/component breakdown and void compressor warranty.**

***DANGER: Prior to performing any maintenance on the compressor, ensure compressor is disconnected from its power source and cannot be re-energized until the maintenance to be performed is complete. DO NOT perform maintenance with pressure in the tank. Relieve pressure prior to maintenance being started.***

### Maintenance Schedule

The table below is a generalized maintenance schedule based on the normal usage of a compressor. Your specific needs may vary based on operating environment and duty.

Item	Frequency	Comment
Cleanliness	Daily	Keep the compressor and the surrounding area clean. Wipe off oil, spills, and dirt/dust.
Oil Level	Daily	Check oil level while the unit is <b>OFF</b> . If oil is low add to fill point. If level is high, drain off oil.
Tank Pressure	Daily	Check unit for air leaks.
Tank	Daily	Drain the tank daily at the end of use. <b>DO NOT</b> attempt to store air for prolonged periods of time. The electrical cost is minuscule compared to replace a rusted out or ruptured tank. <b>DO NOT</b> attempt to repair a damaged tank.
Anchors	Weekly	Ensure anchors are holding the unit securely and are not loose.
Anti-Vibration Pads	Weekly	Check for wear. Verify they are in place and not damaged or rotted.

Belt	Monthly	Verify belt tension. Replace if excessively loose or damaged.
Environment	Quarterly (four times per year)	Air temperature should not exceed recommended levels. Humidity where compressor is stored should not exceed 70%. Consider relocating compressor if these conditions cannot be met.
Wiring	Semi Annually (twice a year)	Have an electrician check connection from power supply and all subsequent connections on the unit.
Tank	Yearly	Inspect for rust or corrosion. <b>DO NOT</b> attempt to repair a damaged tank.
Entire Unit	Yearly	Lock unit out and detail clean.
Air Filter(s)*	See Comments	Air filters should be changed after the first 100-hour break in period and every 90 days after that. The frequency will increase in environments with air contaminants such as dust, paint, dirt, etc.
Oil*	See Comments	Oil should be changed after the first 70-hour break in period and every 180 days OR 1000 hours. after that. This will increase in frequency depending on actual compressor use and hours unit is running.

\*Frequency of these changes are a generalization and may be subject to change based on compressor environment, hours, and application.

**Oil Choice**

It is strongly advised to use only Airbase Industries Smart Piston Compressor Oil. Check with your warranty/extended warranty guidelines to verify oil selection and use

**Oil Disposal**

Compressor oil is not trash and **MUST NOT** be disposed of in regular trash or discarded into the environment. You **MUST** dispose of waste oil from your unit per all applicable federal, state, and/or local codes. Failure to do so may damage the environment and subject yourself and/or your business to fines and legal issues.

**TROUBLESHOOTING**

Some unit issues can be fixed simply by verifying the following guide. It is advised to go through the guide prior to calling technical support to help expedite the assistance process.

<b>Issue</b>	<b>Action</b>
Compressor does not run	Check unit power supply. Verify incoming voltage from power supply to unit. Check that breakers are functioning correctly. Verify wiring is connected correctly and not loose.
Compressor cycles frequently	Check for leaks in facility/shop air lines or air system. Check for stuck tools or machine leaks. Check pressure settings and PSI cycle settings on switch.
Compressor does not reach pressure	Check unit is not running in continuous run, check FEATURES section for more information. Check CFM consumption of machines/tools to ensure they do not exceed compressor capability. Check tools for <b>CONSTANT CFM</b> rating, not average. Average ratings do not reflect consumption and are often 66% lower than actual CFM consumption  Check for leaks in air lines and/or on unit.
Oil level low	Verify oil level while unit is off and cool. Top oil off and monitor oil level. If it drops again check for oil leaks and check correct oil is being used
Compressor is running loud	Ensure anchor bolts are in use and are snug. Check vibration pads for excess wear, replace as needed.  Ensure unit is not hard lined to air system. Unit should be connected by flexible hose to air systems to prevent vibration noise.
Compressor will not shut off	Check incoming power location. If wired incorrectly power is going directly to motor and can cause tank damage. Shut unit down and verify wire diagram. If problem continues contact customer support.
Magnetic starter has kicked off	Verify duty cycle on unit. It should not exceed 60-40 run/rest cycle if it does consider upsizing unit and/or tank size. Thermal overloads are designed to protect the motor from overheating. Overusing unit can cause thermal overloads to trip. Allow the unit to cool, reset magnetic starter and continue use. If problem occurs again contact customer support.
Getting oil blow by	Verify pump has passed the break in time: 70-150 hours of active run time. Ensure unit is not running in continuous mode prior to break in period being completed (this can cause increase blow by during break in). For cases after break in period contact customer support.



Assembled by  
EMAX Compressor  
Englewood, OH 45315  
[emaxcompressor.com](http://emaxcompressor.com)

**PUMP PARTS DIAGRAMS**

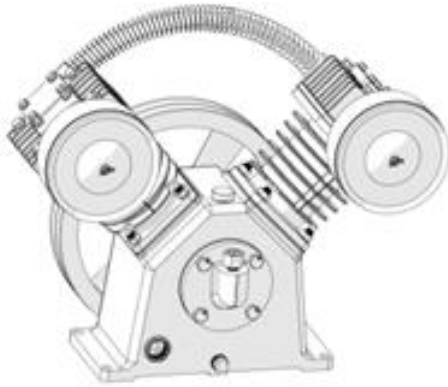

**APP2V0518S  
5HP  
SINGLE STAGE**



**HEAD AND VALVE ASSEMBLY**

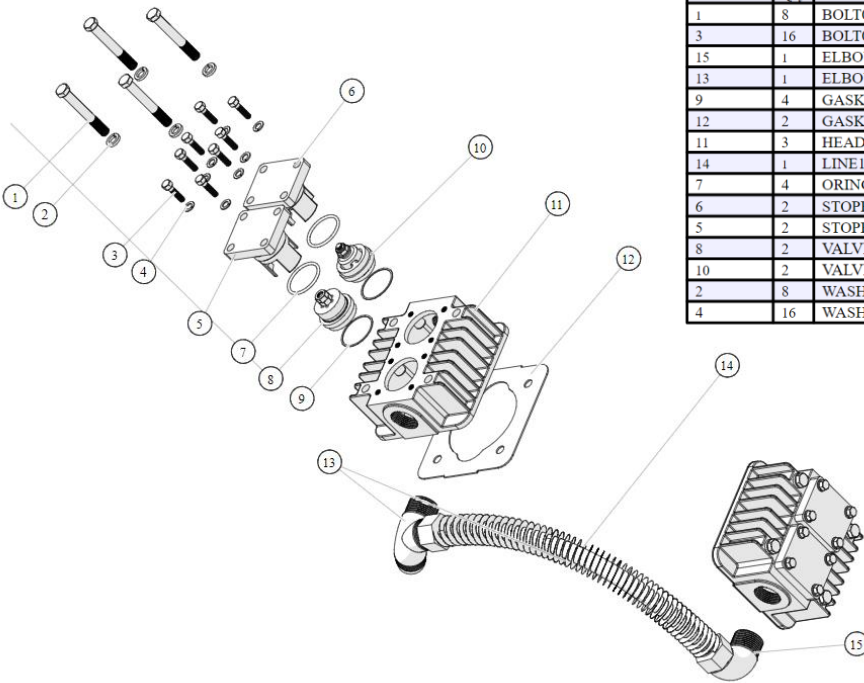

ITEM NO.	Qty	PART #	DESCRIPTION
1	8	BOLT038	HEX BOLT M10-1.5-75
3	16	BOLT080	HEX BOLT M6-1.0-25
15	1	ELBOW005	ELBOW-90 EXHAUST 1.0 PIPE TO M FLARE
13	1	ELBOW022	ELBOW-120 EXHAUST 1.0 PIPE TO M FLARE
9	4	GASKET021	COOPER VALVE GASKET FOR APP02V0518S
12	2	GASKET117	HEAD GASKET FOR APP02V0518S
11	3	HEAD020	
14	1	LINE153	EXHAUST LINE FOR APP02V0518S
7	4	ORING048	VALVE STOPPER ORING 39MM ID - 3 MM WIDTH
6	2	STOPPER009	INTAKE VALVE STOPPER FOR APP02V0518S
5	2	STOPPER010	EXHAUST VALVE STOPPER FOR APP02V0518S
8	2	VALVE129	EXHAUST VALVE FOR APP02V0518S HIGH FLOW COIL SPRING
10	2	VALVE130	INTAKE VALVE FOR APP02V0518S HIGH FLOW COIL SPRING
2	8	WASHER009	M10 LOCK WASHER
4	16	WASHER017	8MM LOCK WASHER

**CYLINDERS**

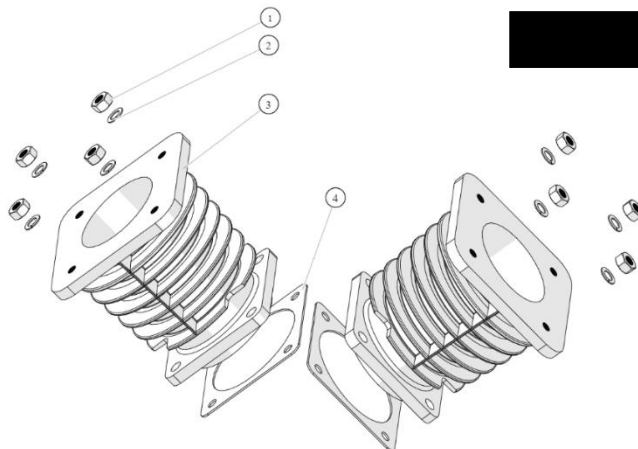

ITEM NO.	Qty	PART #	DESCRIPTION
3	2	CYLINDER021	CYLINDER FOR APP02V0518S
4	2	GASKET116	CYL GASKET FOR APP02V0518S
1	8	NUTS047	HEX NUT M10 - 1.5 PLAIN FINISH
2	8	WASHER009	10MM LOCK WASHER

**CASE AND ROTATING ASSEMBLY**

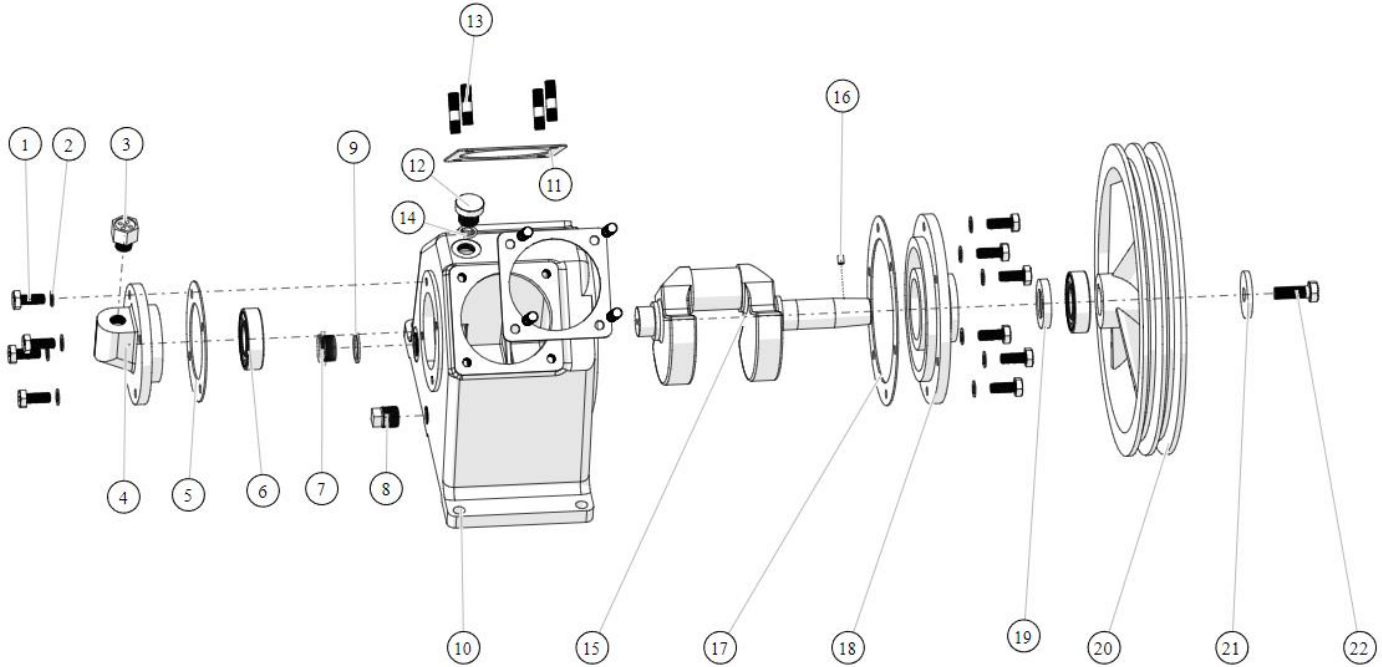

ITEM NO.	Qty	PART #	DESCRIPTION
6	2	BEARING021	NON SHIELDED BEARIN 62MM OD X 30MM ID X 16W
22	1	BOLT024	HEX BOLT M12-1.75-30
1	10	BOLT043	BOLT HEX M10-1.5-25
3	1	BREATHER006B	CRANKCASE BREATHER 3/8 NPT
15	1	CRANK013	CRANKSHAFT USED FOR APP2V0518S
10	1	CRANKCASE013	CRANKCASE V STYLE 2 CYL 18 CFM FOR APP02V0518S
8	1	FITTING036	1/2 INCH NPT PLUG SQ DRIVER
20	1	FLYWHEEL010	FLYWHEEL FOR APP02V0518S
9	1	GASKET106	COMPOSITE SEALING WASHER
5	1	GASKET114	BEARING COVER GASKET FOR APP2V0518S
17	1	GASKET115	REAR CRANKCASE HOUSING GASKET FOR APP02V0518S
11	2	GASKET116	CYL GASKET FOR APP02V0518S

ITEM NO.	Qty	PART #	DESCRIPTION
4	1	HOUSING044	FRONT CRANK HOUSING FOR APP02V0518S
18	1	HOUSING045	REAR CRANK BEARING HOUSING FOR APP02V0518S
14	1	ORING047	14MM X 2.5MM (19MM OD) Oil-Resistant Soft Buna-N O-Rings
16	1	PIN020	ANTO ROTATION PIN 6MM X 8MM LG
12	1	PLUG021	FILL PLUG M20 - 2.5 - 15 KNURLED HEAD
19	1	SEAL025	REAR CRANK HOUSING SEAL FOR APP02V0518S
7	1	SIGHTGLASS007	OIL LEVEL SIGHTGLASS
13	8	STUD005	10MM-1.5 - 40 CYL STUD FOR APP02V0518S
2	10	WASHER0009	10MM LOCK WASHER
21	1	WASHER061	FLYWHEEL FLAT WASHER 47 MM OD

**PISTON/ROD/RINGS**

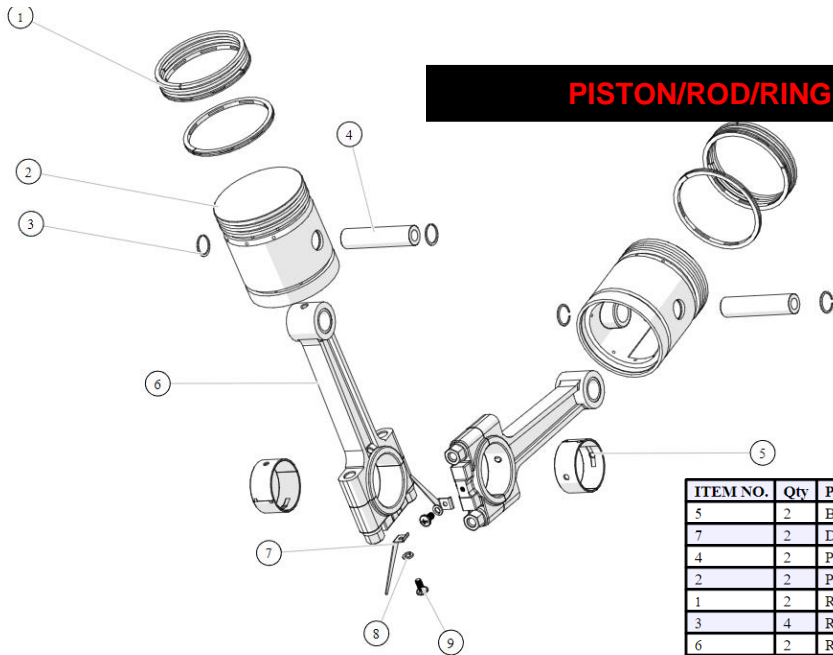

ITEM NO.	Qty	PART #	DESCRIPTION
5	2	BEARING022	ROD BEARING (SET) FOR APP022V0518S
7	2	DIPPER008	OIL DIPPER FOR APP02V0518S
4	2	PIN021	PISTON WRIST PIN FOR APP02V0518S
2	2	PISTON016	80MM PISTON USE IN APP02V0518S
1	2	RING027	RING SET OF 4 FOR APP02V0518S
3	4	RING028	WRIST PIN SNAP RING USED FOR APP02V0518S
6	2	ROD015	CONNECTING ROD FOR APP02V0518S
9	2	SCREW017	M5- .8MM-10MM Pan Head Combination Phillips/Slotted Screws
8	2	WASHER060	5MM Lock Washer

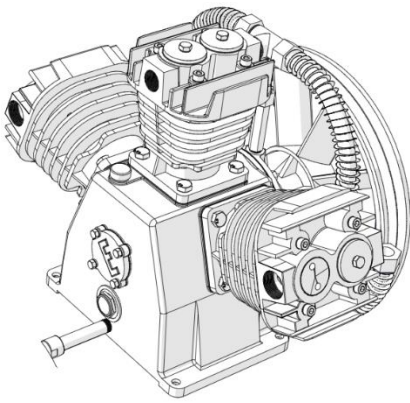

**APP3Y0732TR2  
7.5HP  
TWO STAGE**

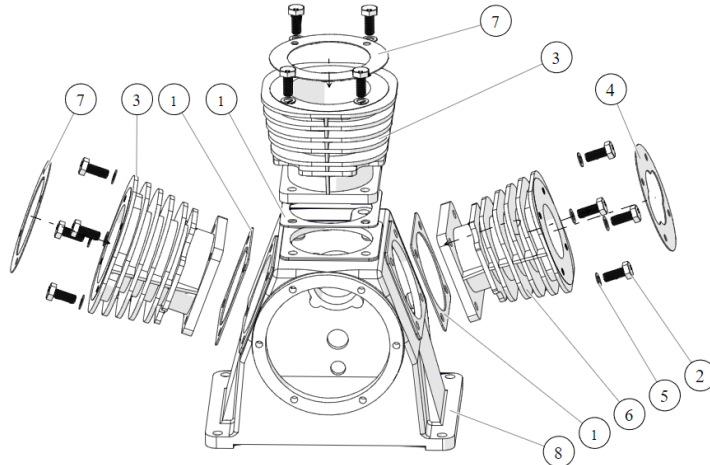

**CYLINDERS**

ITEM NO.	Qty	PART NUMBER	DESCRIPTION	TORQUE
2	12	BOLT043	BOLT HEX M10-1.5-25	34 FT-LBS
8	1	CRANKCASE004	7HP 3 CYLINDER CRANKCASE	
3	2	CYLINDER019	LP CYLINDER 7HP PUMP07HP02	
6	1	CYLINDER020	65M HIGH PRESSURE CYLINDER	
1	3	Gasket024	GASKET, CYLINDER, EC31 EC71	

ITEM NO.	Qty	PART NUMBER	DESCRIPTION	TORQUE
7	2	GASKET110	LP HEAD GASKET PUMP07HP02	
4	1	GASKET111	HP HEAD GASKET PUMP07HP02	
5	12	WASHER0009	10MM LOCK WASHER	

**COOLER AND LINES**

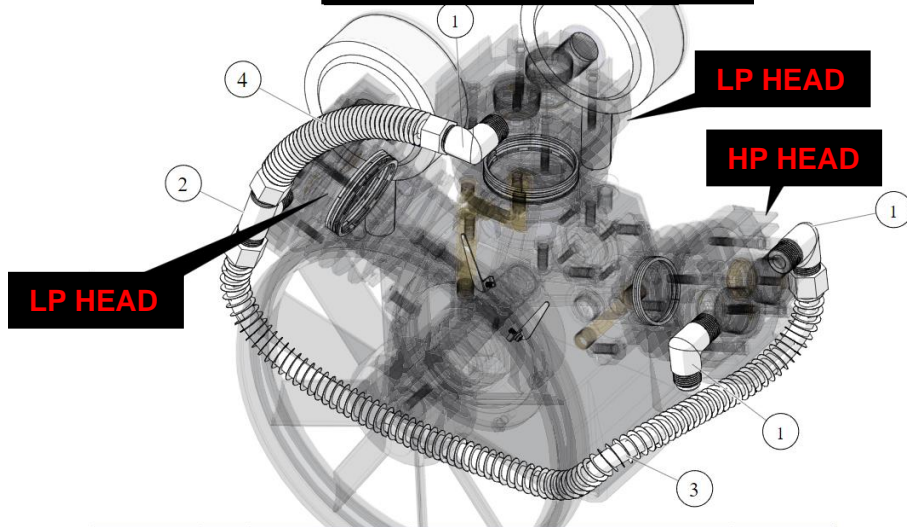

ITEM NO.	Qty	PART NUMBER	DESCRIPTION	TORQUE
1	3	ELBOW009	EXHAUST 90 TO FLARE EC31,71	
4	1	LINE144	LP INT TO LP EXH FINNED LINE	
3	1	LINE145	LP INT TO HP EXH FINNED LINE	
2	1	TEE007	EXHAUST, 3/4" TO M FLR EC71	

**HEAD AND VALVE ASSEMBLY**

ITEM NO.	Qty	PART NUMBER	DESCRIPTION	TORQUE
1	4	BOLT076	HEX BOLT M8-1.25-25	28 FT-LBS
23	12	BOLT085	BOLT S-H M8-1.25-60MM	17 FT-LBS
2	4	COVER008	Cover, Valve, EC5 EC10	
3	6	GASKET040	GAS,VAL,COPECS,EC10	
25	4	GASKET041	LP HP EXHAUST VALVE COVER GASKET	
19	1	HEAD018	HEAD, HP PUMP07HP02	
4	2	HEAD019	HEAD, LP PUMP07HP02	
20	3	RETAINER003	LP HP EXHAUST VALVE RETAINER	
28	3	RETAINER005	VALVE RETAINER (SHORT .600)	
7	2	STOPPER001	INTAKE VALVE STOPPER	
24	4	STOPPER008	STOPPER008 HP INT/EXT LP EXT ONLY	
27	3	VALVE040	HP/LP INTAKE VALVE ASSEMBLY	
26	3	VALVE041	EXHAUST VALVE EC5-EC10	
21	4	WASHER013	8MM COPPER WASHER	
22	10	WASHER017	8MM LOCK WASHER	

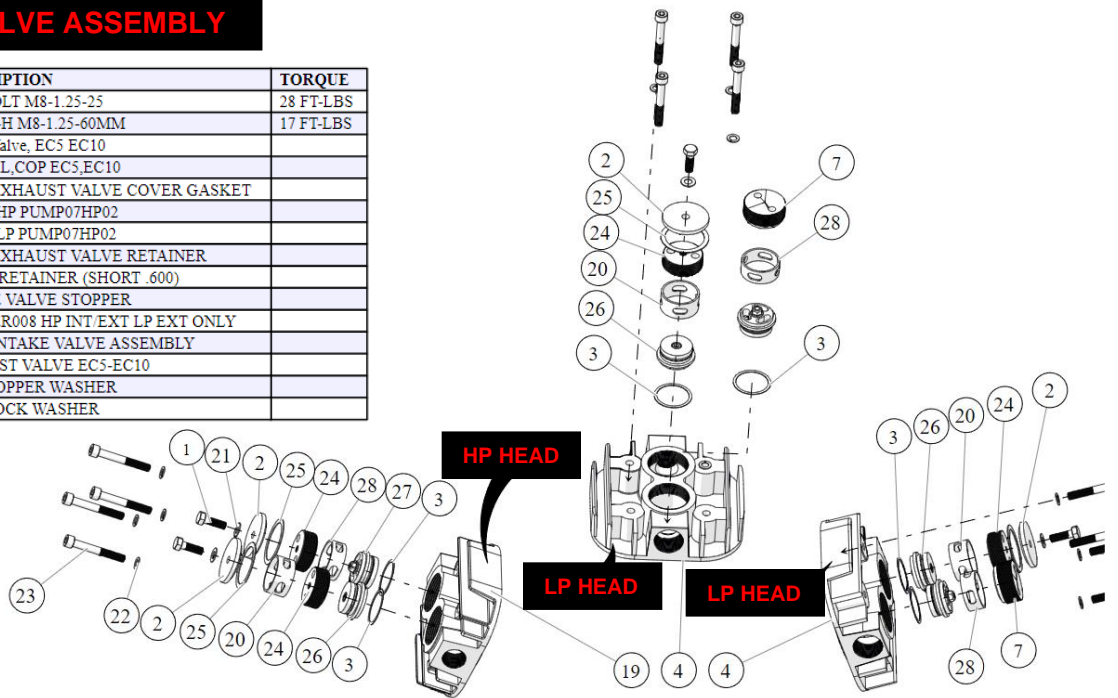

**CRANKCASE**

ITEM NO.	Qty	PART NUMBER	DESCRIPTION	TORQUE
13	1	BEARING004	BEARING, CRANK, LARGE EC71	
5	1	BEARING017	BEARING, CRANK, SMALL, EC31,71	
14	6	BOLT022	BOLT HEX M8-1.25-20MM	
24	1	BOLT031	BOLT HEX M10-1.5-40MM	
1	4	BOLT080	HEX BOLT M6-1.0-25	20 FT-LBS
15	1	BREATHER006	CRANKCASE BREATHER	
16	1	COVER024	COVER, CRANKCASE, FRONT, EC71	
6	1	COVER025	COVER, CRANKCASE REAR EC31,71	
17	1	CRANK005	CRANK, EC71	
9	1	CRANKCASE004	7HP 3 CYLINDER CRANKCASE	
3	1	FITTING076	3/8 NPT 4" PIPE	
2	1	FITTING077	FITTING, CAP, 3/8"	
18	1	FLYWHEEL006	FLYWHEEL, 2 BELT EC71	
12	3	Gasket024	GASKET, CYLINDER, EC31 EC71	
8	1	GASKET081	GASKET, CRANK COVER	

ITEM NO.	Qty	PART NUMBER	DESCRIPTION	TORQUE
10	1	GASKET088	OIL FILL GASKET	
7	1	GASKET089	RETAINER GASKET	
19	1	GASKET099	GASKET, COVER, FLY-WHL END EC71	
20	1	KEY004	KEY, FLYWHEEL, EC20,31,71	
11	1	PLUG008A	OIL FILL PLUG, ALUMINUM	
21	1	RING024	RING, SNAP O.D. CRANK EC31,71	
22	1	SEAL008	SEAL, SHAFT, 3CYL 2ST, EC31,71	
28	1	SIGHTGLASS006	OIL LEVEL SIGHTGLASS	
25	1	WASHER009	10MM LOCK WASHER	
23	6	WASHER017	8MM LOCK WASHER	
27	1	WASHER027	WASHER, FLAT 30MM	
26	1	WASHER028	WASHER 10M/FLYWHL EC71 EC31	
4	4	WASHER056	WASHER LOCK 6MM	

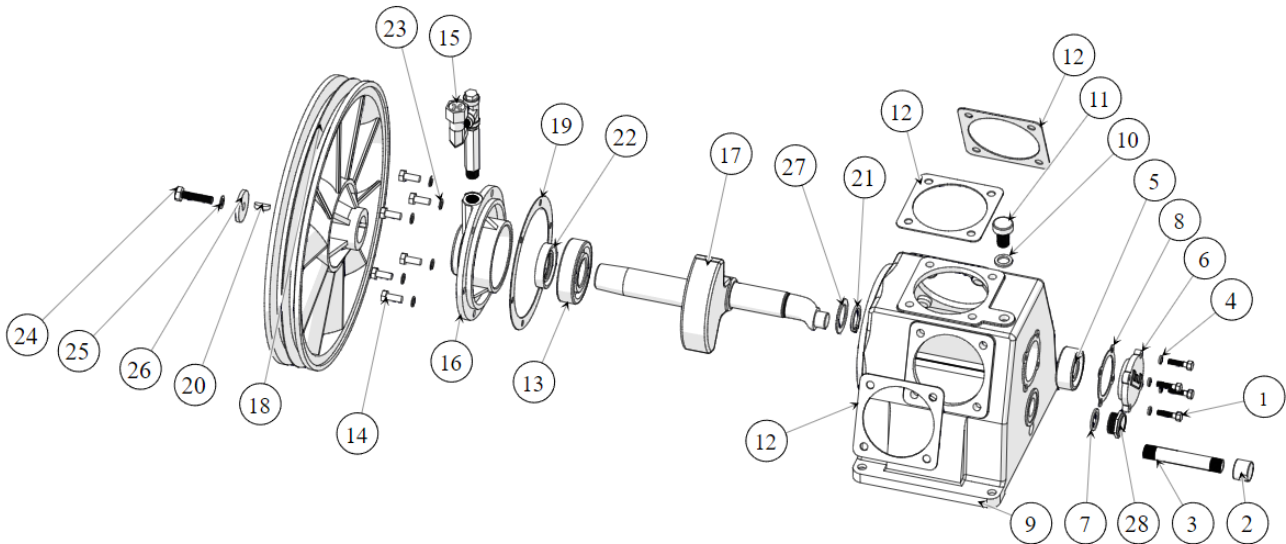

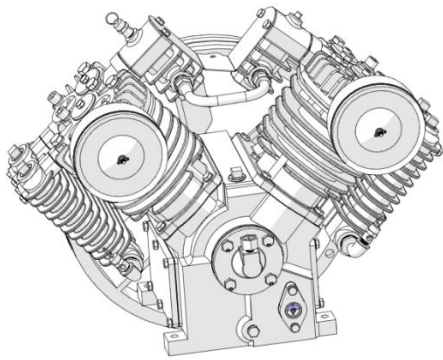

**APP4V1043TR2  
10HP  
TWO STAGE**

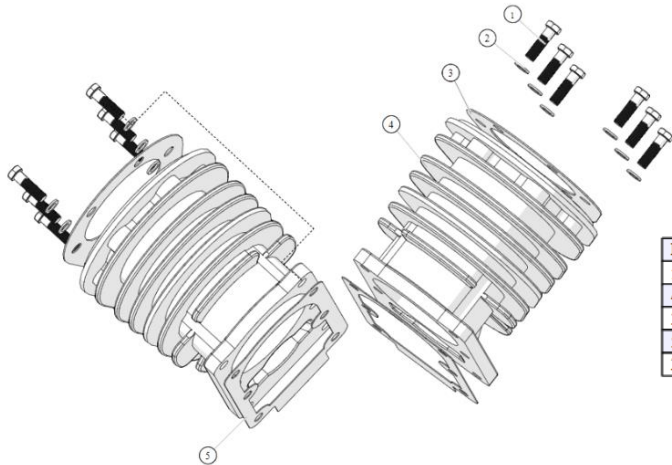

**CYLINDERS**

ITEM NO.	Qty	PART #	DESCRIPTION	TORQUE
1	12	BOLT016	HEX BOLT M10-1.5-35	33 - 36 FT-LBS
4	2	CYLINDER011	HP/LP PISTON CYLINDER	
3	2	GASKET033	HEAD GASKET	
5	2	GASKET044	LOWER PISTON CYLINDER GASKET	
2	12	WASHER014	10MM COPPER WASHER	

**ROTATING ASSEMBLY**

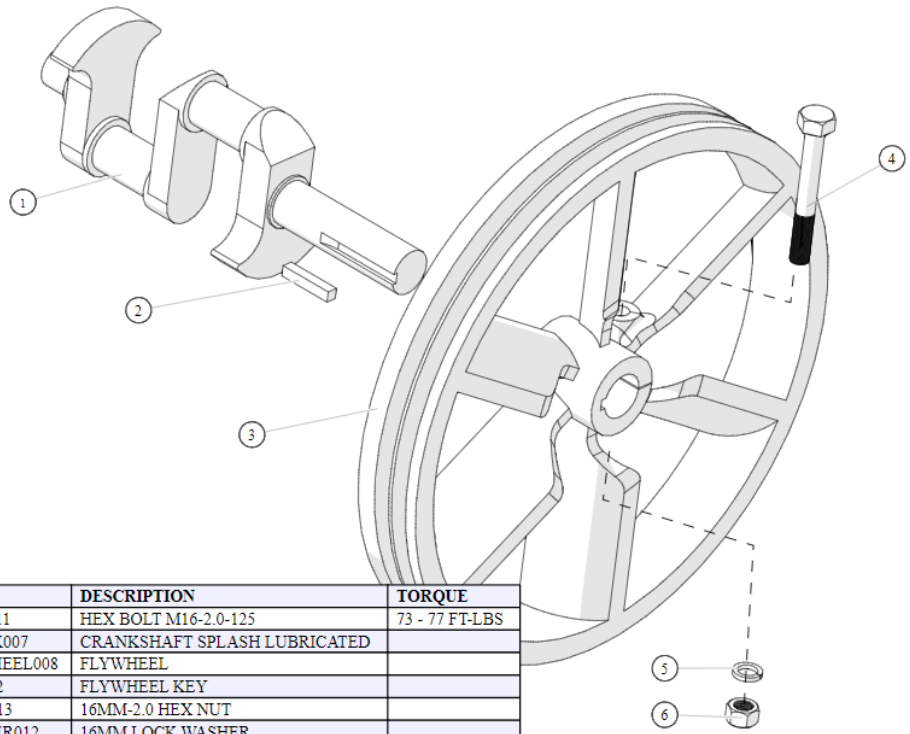

ITEM NO.	Qty	PART #	DESCRIPTION	TORQUE
4	1	BOLT011	HEX BOLT M16-2.0-125	73 - 77 FT-LBS
1	1	CRANK007	CRANKSHAFT SPLASH LUBRICATED	
3	1	FLYWHEEL008	FLYWHEEL	
2	1	KEY002	FLYWHEEL KEY	
6	1	NUTS013	16MM-2.0 HEX NUT	
5	1	WASHER012	16MM LOCK WASHER	

**CRANK CASE ASSEMBLY**

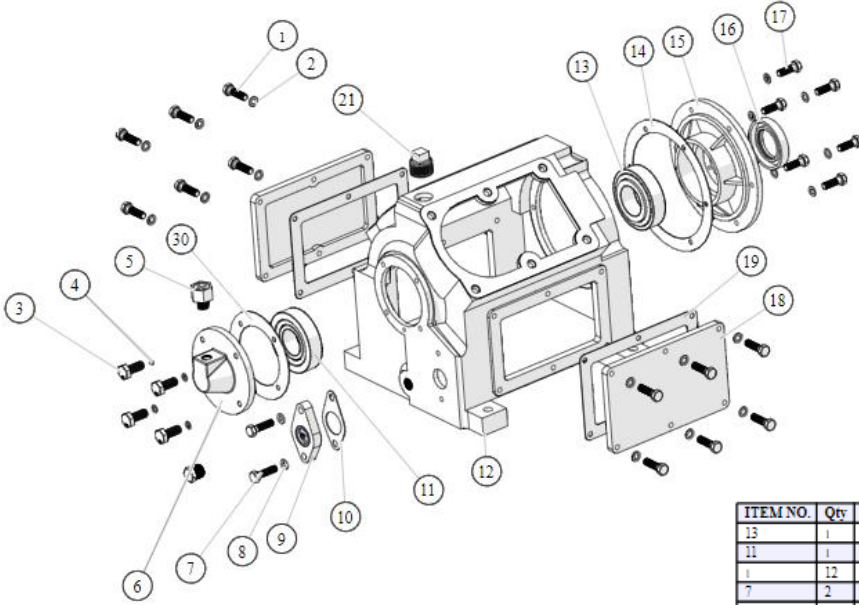

ITEM NO.	Qty	PART #	DESCRIPTION	TORQUE
13	1	BEARING006	CRANK BEARING REAR	
11	1	BEARING012	CRANK BEARING FRONT	
1	12	BOLT012	HEX BOLT M8-1.25-30	13 - 16 FT-LBS
7	2	BOLT012	HEX BOLT M8-1.25-30	13 - 16 FT-LBS
3	4	BOLT043	BOLT HEX M10-1.3-25	33 - 36 FT-LBS
17	6	BOLT076	HEX BOLT M8-1.25-25	13 - 16 FT-LBS
5	1	BREATH006	CRANKCASE BREATHER 1/4 NPT	
15	1	COVER005	BEARING HOUSING	
18	2	COVER006	CRANKCASE ACCESS COVER	
6	1	COVER007A	FRONT BEARING COVER NON-CENTRIFUGAL	
12	1	CRANKCASE007	CRANKCASE FOR V4 SPLASH LUBE	
21	1	FITTING035	3/4 NTP PIPE PLUG	
14	1	GASKET035	BEARING HOUSING GASKET	
30	1	GASKET036	CONNECTOR PLATE GASKET	
19	2	GASKET045	CRANKCASE ACCESS COVER GASKET	
10	1	GASKET048	SIGHTGLASS GASKET	
16	1	SEAL010	CRANKSHAFT SEAL	
9	1	SIGHTGLASS004	OIL SIGHTGLASS	
2	18	WASHER013	8MM COPPER WASHER	
8	2	WASHER016	6MM FLAT WASHER	
4	4	WASHER051	6M COPPER SEALING WASHER	

**ROD/PISTON ASSEMBLY**

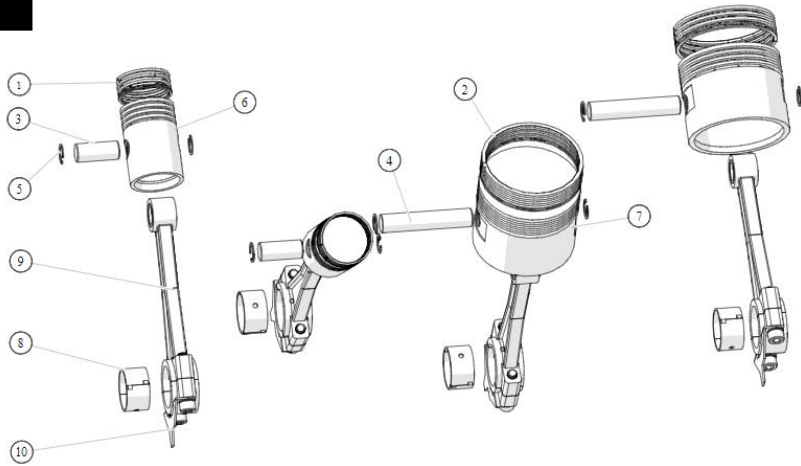

ITEM NO.	Qty	PART #	DESCRIPTION	TORQUE
8	4	BEARING005	BEARING SET (2 HALVES = 1 BEARING SET)	
10	4	DIPPER001		
4	2	PDN008	LOW PRESSURE PISTON WRIST PIN	
3	2	PDN010	HIGH PRESSURE PISTON WRIST PIN	
7	2	PISTON007	LOW PRESSURE PISTON	
6	2	PISTON008	HIGH PRESSURE PISTON	

ITEM NO.	Qty	PART #	DESCRIPTION	TORQUE
1	2	RING011	HP 10HP V4 RING SET	
2	2	RING012	LP 10HP V4 RING SET	
5	8	RING019	LP/HP WRIST PIN RETAINING SNAP RING	
9	4	ROD010	CONNECTING ROD LP/HP SPLASH LUBE	

**HEAD/VALVE ASSEMBLY**

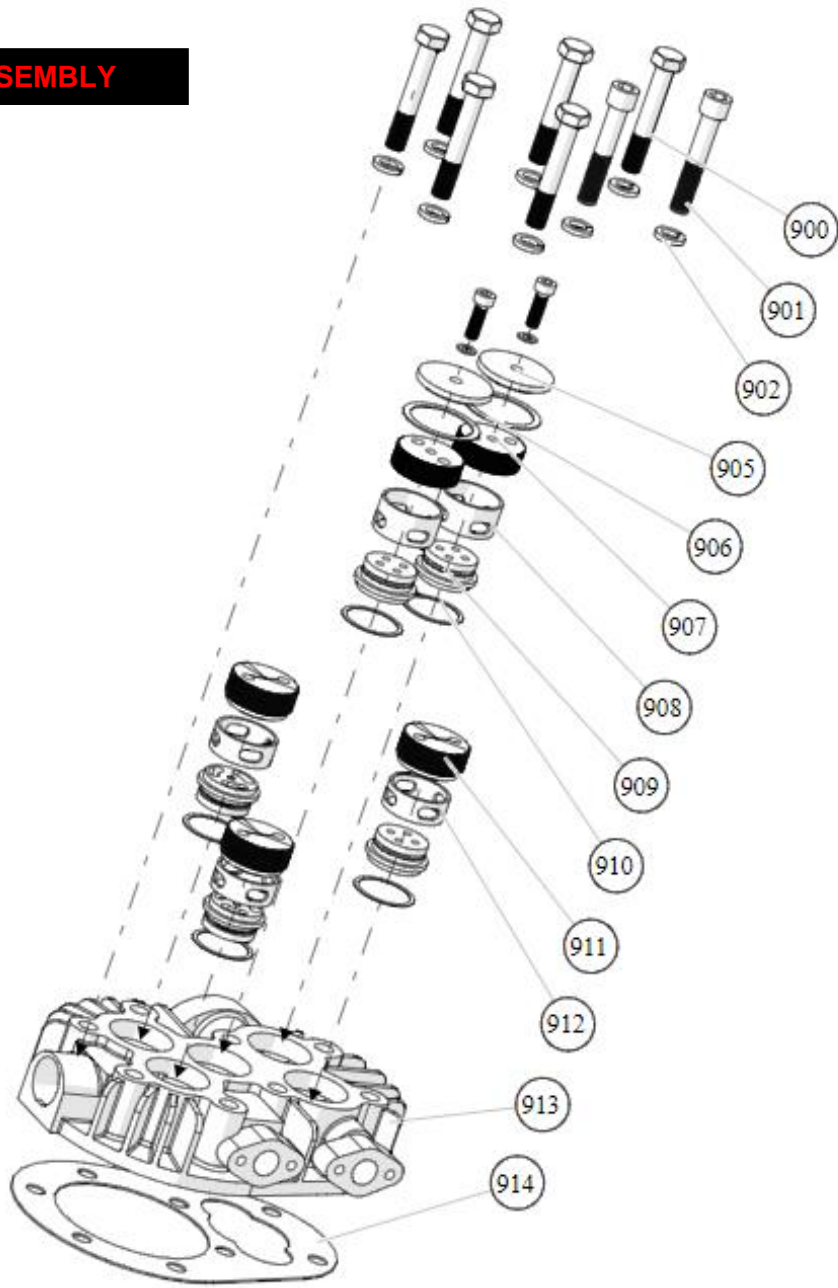

ITEM NO.	Qty	PART #	DESCRIPTION	TORQUE
900	6	BOLT018	HEX BOLT M12-1.75-75	62 - 66 FT-LBS
901	2	BOLT078	ALLEN HEAD BOLT M12-1.75-70	62 - 66 FT-LBS
905	2	COVER008	LP/HP EXHAUST VALVE COVER	
914	1	GASKET033	HEAD GASKET	
910	5	GASKET040	COPPER VALVE GASKET	
906	2	GASKET041	LP/HP EXHAUST VALVE COVER GASKET	
913	1	HEAD003	RIGHT HEAD, LEFT HEAD P/N HEAD010	
908	2	RETAINER003	LP/HP EXHAUST VALVE RETAINER, .834 TALL	
912	3	RETAINER005	VALVE RETAINER (SHORT .600), .63 TOP	
911	3	STOPPER001	INTAKE VALVE STOPPER	
907	2	STOPPER002	LP/HP EXHAUST VALVE STOPPER	
909	5	VALVE125	LP/HP EXHAUST VALVE	
902	8	WASHER010	M12 LOCK WASHER	

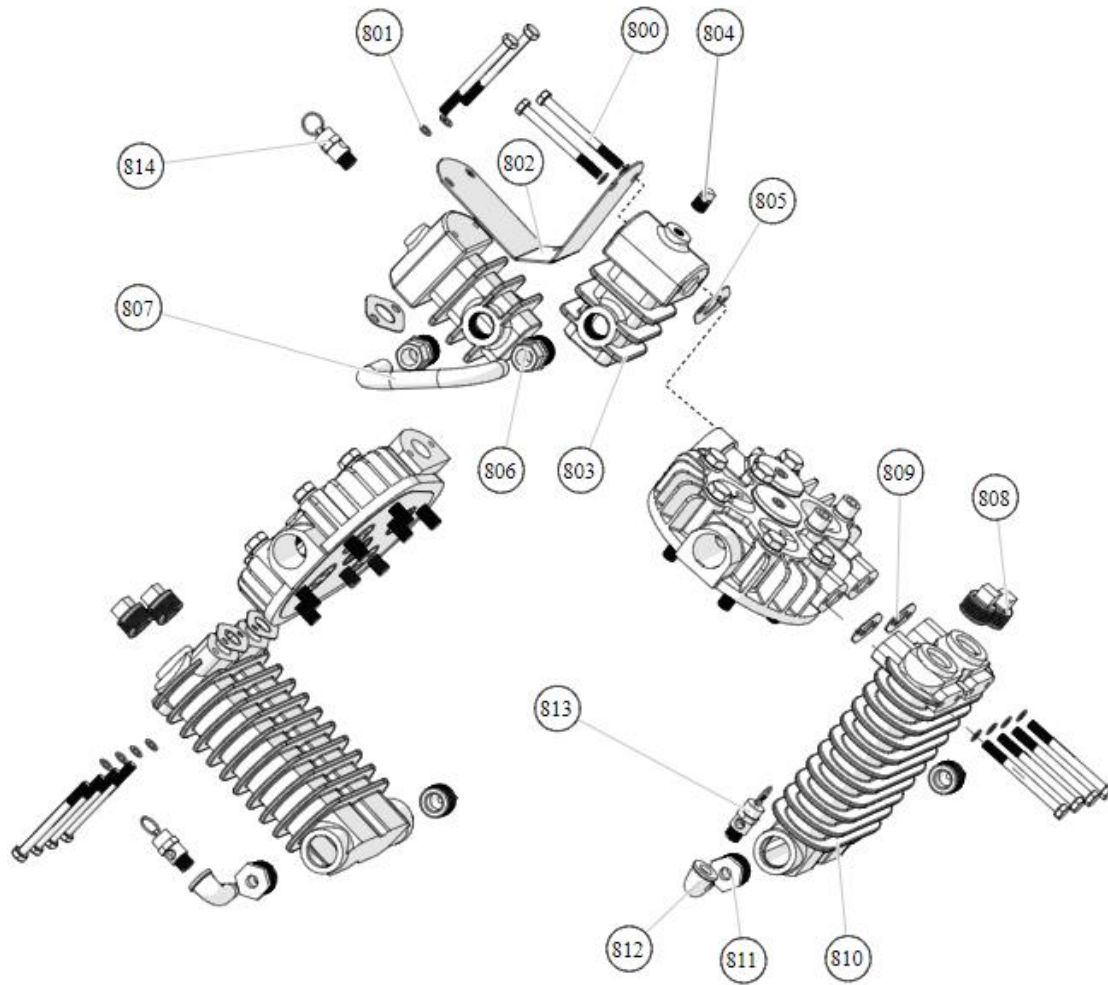

ITEM NO.	Qty	PART #	DESCRIPTION	TORQUE
800	12	BOLT019	HEX BOLT M8-1.25-90	13 - 16 FT-LBS
802	1	BRACKET067	GUARD BRACE SUPPORT (SPLIT COOLER)	
810	2	COOLER002	INNER COOLER	
803	2	COOLER016	7.5HP V4 SPLIT COOLER	
806	2	FITTING003	1/4 NPT MALE TO 6MM COMPRESSION FITTING	
811	2	FITTING016	3/4 MALE TO 1/4 FEMALE BUSHING NPT	
808	6	FITTING035	3/4 NPT PIPE PLUG	
804	1	FITTING037	1/4" NPT PIPE PLUG	
812	2	FITTING089	1/4 STREET L	
809	4	GASKET034	INNER COOLER GASKET	
805	2	GASKET043	AFTER COOLER GASKET	
807	1	LINE152	7.5HP SPLIT COOLER BRIDGE LINE	
814	1	VALVE008	POP-OFF VALVE 200 PSI	
813	2	VALVE055	POP-OFF VALVE 70 PSI	
801	12	WASHER013	3MM COPPER WASHER	

