

Customer/客户: _____



Li-ion Polymer Battery Pack Specification

锂离子聚合物电池组合规格书

Pack Type/组合类型: Cell+PCM+/电芯+保护板
 Battery Model /电池型号: YJ 903545-1800mAh
 Cell Capacity/电芯容量: 1800mAh
 Customer Code/客户代码: 8.3.1.03.01
 Total Page/文件页数: 16

Prepared By/Date 编制/日期	Checked By/Date 审核/日期	Approved By/Date 批准/日期
刘小明	占志辉	刘秋玲
2020-12-08	2020-12-08	2020-12-08

Customer Approval 客户承认 (Stamp) (盖章)	Tested By/Date 测试/日期	Checked By/Date 审核/日期	Approved By/Date 批准/日期

Add: Block B6, Tianrui Industrial Park, Fuyuan 1st RD, Fuyong Town, Shenzhen City, Guangdong Province, China.

地址: 中国广东省深圳市宝安区福永镇福园一路天瑞工业园 B6 栋

Te1(电话): 86 (0) 755-29707067 Fax(传真): 86 (0) 755-27390515

网址: <http://www.yjbattery.com>



我们致力成为受人敬重的世界领先的电池产品制造商
We are committed to be a respected leading manufacturer of energy in the world !

Content

目录

1. Revision Records 变更履历.....	3
2. Scope 适用范围.....	4
3. Initial Dimension 初始尺寸.....	4
4. Specification 产品规格.....	5
5. General specification 常规性能.....	6
6. Capability to environment 环境性能.....	7
7. Mechanical properties and Safety Characteristic 安全性能和机械性能.....	7
8. Protection Circuit 保护电路.....	11
9. Warnings 警告.....	12
10. Cautions 注意.....	13
11. Notice for Design of Battery Pack 电池外壳设计注意事项.....	14
12. Handling of Battery 电池操作注意事项.....	14
13. Period of Warranty 保质期.....	15
14. Others 其它事项.....	15
15. Package sketch map 包装示意图	16

2.Scope 适用范围

This specification describes the basic performance, technical requirement, testing method ,warning and caution of the Li-ion Polymer rechargeable battery pack, the pack defined in this documentation is an assembly which include battery, PCM ,wire etc,the specification only applies to YJ POWER GROUP LIMITED.

本标准规定了锂电池可充电池的基本性能、技术要求、测试方法及注意事项，电池组合定义的是包括电芯，保护板和连接线等的组合，本标准只适用于深圳市言九电子科技有限公司所生产的锂离子电池。

YJ Battery safety performance is designed according to RoHS standard and 《Lithium ion cells and batteries used in portable electronic equipment-Safety requirements》 GB31241-2014 compliant.

言九电池符合 RoHS 标准和《便携式电子产品用锂离子电池和电池组安全要求》GB31241-2014。

3. Initial Dimension 初始尺寸

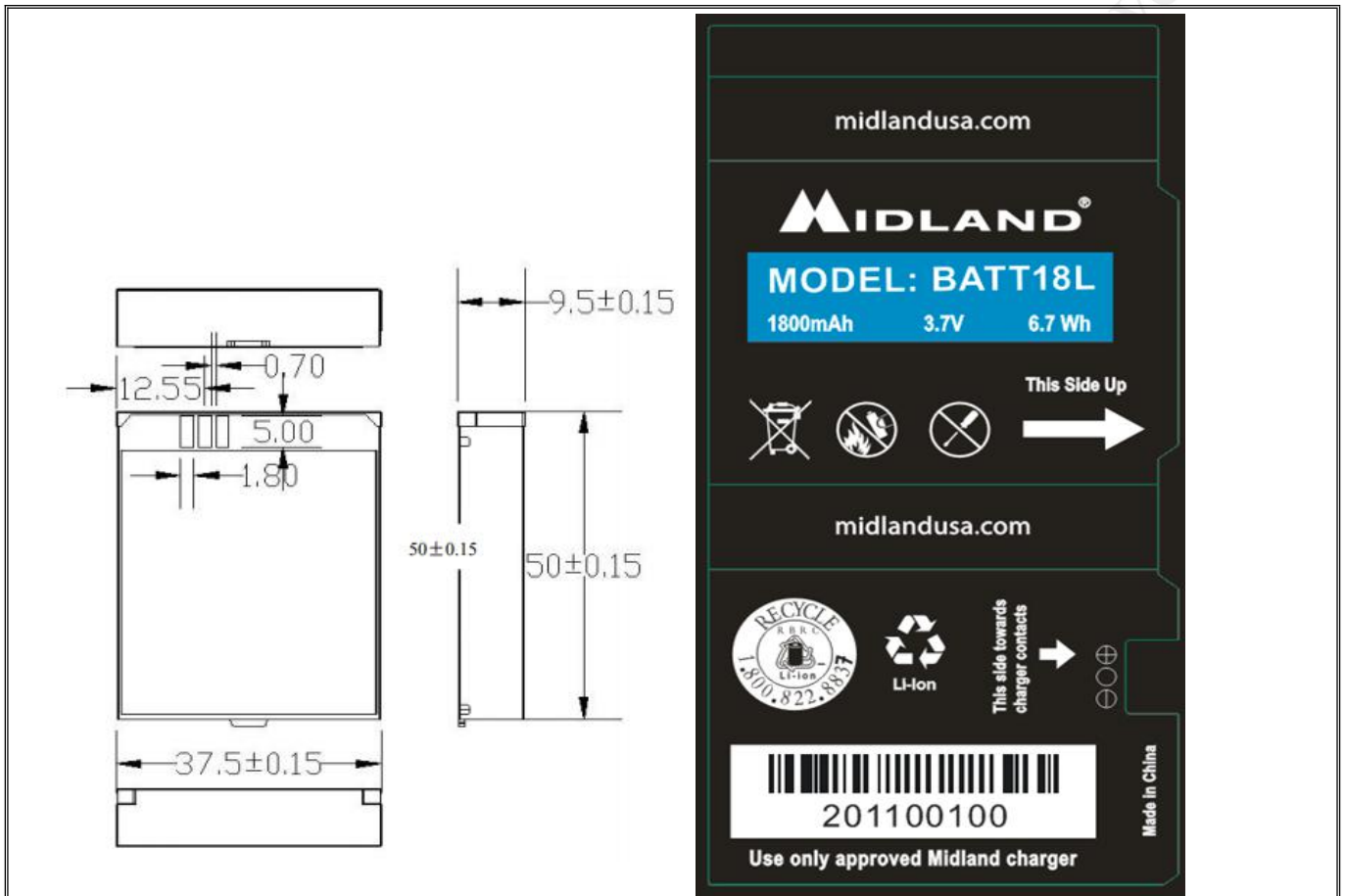

Unit 单位 (mm)

Remark 备注: Date (日期随出货日期更新)

Note: Single side edge/ double side edge / soft seal / hard sealing / protection panel PCB color green / black oil / silk screen / line layout inconsistency cannot affect the performance.

免责声明: 电芯单折边/双折边及软封/硬封和保护板 PCB 颜色绿油/黑油/丝印/线路布局不一致不影响性能均可。

T (厚度) Max	9.5±0.15	W (宽度)	37.5±0.15	H(高度)x	50±0.15
T ₁ (循环后厚度) After cycle	T*1.06	L (长度)	/	L1 (长度)	
L2(长度)	/	Wire (引线)	/		
PCM (保护板)	S-8261DAI+8205A*2+10KNTC				

4.Specification 产品规格

NO.	Item 项目	Specifications 规格要求
4.1	Nominal capacity 标称容量	1800mAh 0.2C Discharge (0.2C 放电)
	Minimum capacity 最小容量	1750mAh 0.2C Discharge (0.2C 放电)
4.2	Initial Impedance 初始内阻	≤150mΩ
4.3	Battery Weight 电池重量	Approx(约): 36g
4.4	Nominal voltage 标称电压	3.7V
	Fully charge voltage(FC) 满充电压 FC	4.2V Defined in this DOC: FC = 4.2V
	Fully discharge voltage(FD) 满放电电压 FD	3.0V Defined in this DOC: FD = 3.0V
4.5	Recommended shutdown voltage 建议关机电压	≥3.0V
4.6	Standard charging method 标准充电方法	0.5C CC (constant current) charge to FC, then CV(constant voltage FC)charge till charge current decline to≤0.02C 0.5C CC (恒流) 充电至 FC, 再 CV (恒压 FC) 充电直至充电电流≤0.02C
4.7	Standard charge current 标准充电电流	0°C~15°C 0.2C
		15°C~25°C 0.5C
		25°C~45°C 1C
4.8	Standard discharge current 标准放电电流	-10°C~15°C 0.2C
		15°C~60°C 1C
4.9	4.7 and 4.8 are the current corresponding to the recommended temperature for conventional use of the battery. Destructive tests such as external short circuit at high and low temperature, internal short circuit and thermal abuse shall be performed in accordance with requirements of 7.7/7.8/7.9. 4.7 和 4.8 是电池常规使用推荐的温度对应的电流,如需测试破坏性实验如高低温外部短路,内部短路,热滥用则需按 7.7/7.8/7.9 要求执行。	
4.10	Charge cut-off voltage 充电截止电压	Ref. 8.1 VDET1
4.11	Discharge cut-off Voltage 放电截止电压	Ref. 8.1 VDET2
4.12	Storage temperature 储存温度	-20°C~60°C ≤1 month
		-20°C~45°C ≤3 month
		-20°C~25°C ≤1 year
4.13	Recoverable capacity 恢复容量	Constant current 0.5C charge to FC, then constant voltage FC charge to current declines to 0.02C, rest for 10min, constant current 0.2C discharge to FD, rest for 10min.Repeat above steps 3 times, recording the maximum capacity. 先用 0.5 C 恒流充电至 FC, 再恒压 FC 充电直至充电电流≤0.02C,搁置 10 分钟,再用 0.2C 电流放电至 FD; 又搁置 10 分钟,重复以上步骤 3 次,记录容量最大值。
		Percentage of recoverable capacity no less than 80% of the initial capacities 恢复容量不低于初始容量的 80%
4.14	Storage Humidity 储存湿度	≤75% RH
4.15	Appearance 外观	Without distortion and leakage 无变形、电解液泄露
4.16	Before shipment voltage 出货电压	3.8V-4.0V
4.17	Standard testing condition 标准测试环境	Temperature(温度) : 23±2°C
		Humidity (湿度) : ≤75%RH
		Atmospheric Pressure (大气压) : 86-106 Kpa

Remark 备注:

1. From 4.1 to 4.16, the testing condition please refer to 4.17 (standard testing condition).
从 4.1 至 4.16 项目，测试环境遵从 4.17（标准测试环境）。
2. Operating temperature（使用温度）: charging(充电) 0°C~45°C; Discharging（放电）: -10°C~60°C.
If the working condition is out of 4.17, the performance will be some shift.
如果工作环境超出 4.17 范围，性能将会有一些偏移。
3. Measuring instrument and equipment requirements 测量仪表与设备要求。
 - Measure the voltage meter accuracy no less than 0.5 magnitude, resistance no less than 10KΩ/V.
测量电压的仪表准确度应不低于 0.5 级，内阻应不小于 10KΩ/V。
 - Measure the current meter accuracy no less than 0.5 magnitude.
测量电流的仪表准确度应不低于 0.5 级。
 - The instrument accuracy measuring time meter no less than ±0.1%.
测量时间的仪表准确度应不低于±0.1%。
 - Measuring temperature meter accuracy no less than ±0.5°C.
测量温度的仪表准确度应不低于±0.5°C。
 - Adjustable constant current source of constant current, in the process of charging or discharging, the current changes shall be within ±1%.
恒流源电流恒定可调，在充电或放电过程中，其电流变化应在±1%范围内。
 - Constant voltage source voltage is adjustable, and its voltage range is ±0.5%.
恒压源的电压可调，其电压变化范围为±0.5%。
 - Measuring instrument accuracy is not lower than 0.02 mm.
尺寸测量仪的准确度不低于 0.02mm。
 - Mass tolerance of the instruments are not more than 0.1 g.
称量重量的仪器感量不高于 0.1g。

5. General specification 常规性能

No.	Item 项目	Test Methods and Condition 测试方法和条件	Criteria 标准
5.1	0.2C Capacity 0.2C 容量	At standard testing condition, After full charge with standard charge, rest 10min, then discharging at 0.2C to voltage FD, recording the discharging time. 在标准测试环境下，标准充饱电后,搁置 10 分钟,然后用 0.2C 电流放电至 FD, 所记录放电时间。	≥300min(分钟)
5.2	Cycle Life 循环寿命	At standard testing condition, constant current 0.5C charge to FC, then constant voltage charge to current declines to 0.02C, rest 10min, constant current 0.2C discharge to FD, rest 10min. Repeat above steps till continuously discharging capacity Higher than 80% of the Initial Capacities of the Cells. 在标准测试环境下，先用 0.5 C 恒流充电至 FC, 再恒压 FC 充电直至充电电流≤0.02C,搁置 10 分钟,再用 0.2C 电流放电至 FD;又搁置 10 分钟,重复以上步骤,直到放电容量是初始容量的 80%。	≥300 times(次)

6 .Capability to environment 环境性能

No.	Item 项目	Test Methods and Condition 测试方法和条件	Criteria 标准
6.1	High/low Temperature 高/低温性能	At standard testing condition, After full charge with standard charge, measure the discharging capacity with discharging current 0.2C till 3.0V cut off voltage at different temperature. (as compared with initial capacity). 在标准测试环境下, 标准充饱电后, 测量电池在不同温度下用 0.2 C 电流放电至 3.0 V 所放出的容量(与初始容量作为比较)。	-10℃ ≥60% 55℃ ≥90%
6.2	Capability of keeping electricity 荷电保持能力	At standard testing condition, After full charge with standard charge, no outer loading circuit, rest the pack 7days, discharging at 0.2C to voltage FD, recording the discharging time. 在标准测试环境下, 标准充饱电后, 无外接负载线路, 电池组合搁置 7 天,然后用 0.2C 放电至 FD,所记录放电时间。	≥285min (分钟)

7. Mechanical properties and Safety Characteristic 安全性能和机械性能

No.	Item 项目	Test Methods and Condition 测试方法和条件	Criteria 标准
7.1	Vibration Test 振动测试	At standard testing condition,After full charge with standard charge, fixed the cell to vibration table and subjected to vibration cycling that the frequency is to be varied at the rate of 1Hz per minute between 10Hz an 55Hz, the excursion of the vibration is 1.6mm. The cell shall be vibrated for 60 minutes per axis of X、 Y、 Z axes. 将标准充电后的电芯固定在振动台上, 沿 X、 Y、 Z 三个方向各振动 60 分钟, 振幅 1.6mm, 振动频率为 10Hz~55Hz, 每分钟变化 1Hz。	No leakage 无泄漏 No fire 不起火 No explosion 不爆炸
7.2	Free Drop 自由跌落	At standard testing condition,After full charge with standard charge.The Battery is to be dropped from a height of 1 meter onto Concrete slab. Free drop one time respectively from X、 Y、 Z positive and negative axis(six Directions). 将标准充电后的电芯从 1 米高度跌落至混凝土板上.从 X、 Y、 Z 正负六个方向各跌落一次。	No leakage 无泄漏 No fire 不起火 No explosion 不爆炸
7.3	Crush 挤压试验	At standard testing condition, After standard charging, Crush between two flat plates. Applied force is about 13 ± 0.78kN(1.72Mpa), Once the maximum force has been applied,the force is released. 电池标准充电后, 电池放置在两块平面金属板间, 施加 13 ± 0.78kN (1.72Mpa) 的作用力, 一旦压力达到最大值即可停止试验。	No fire 不起火 No explosion, 不爆炸

7.4	RT Short-Circuit Test 常温短路测试	After standard charge, the battery is to be short-circuited with copper wire of a maximum resistance load of $80 \pm 20\text{m}\Omega$ for 1 h, At temperature ($20 \pm 5^\circ\text{C}$). 标准充电后, 在常温 ($20 \pm 5^\circ\text{C}$)用 $80 \pm 20\text{m}\Omega$ 的铜线短路电池的正负极 1 小时。	No explosion, no fire. The temperature of the exterior cell casing shall
7.5	High Temperature Short-Circuit Test 高温短路测试	After standard charge, the battery is to be short-circuited with copper wire of a maximum resistance load of $80 \pm 20\text{m}\Omega$ for 1 h, At temperature ($55 \pm 5^\circ\text{C}$). 标准充电后, 在高温 ($55 \pm 5^\circ\text{C}$)用 $80 \pm 20\text{m}\Omega$ 的铜线短路电池的正负极 1 小时。	not exceed 150°C . 不爆炸, 不起火, 电池外部 温度不超过 150°C .
7.6	Impact Test 重物冲击测试	The fully charged battery was placed on the impact table, the metal rod with a diameter of $15.8 \pm 0.2\text{ mm}$ was placed horizontally on the surface of the geometric center of the battery, and a weight of $9.1 \pm 0.1\text{ Kg}$ was used to impact the surface of the metal rod from a high free-fall state of $610 \pm 25\text{ mm}$. 将满充后的电池放置于冲击台上, 将直径为 $15.8 \pm 0.2\text{mm}$ 的金属棒横置在电池几何中心上表面, 采用质量为 $9.1 \pm 0.1\text{Kg}$ 的重物从 $610 \pm 25\text{mm}$ 的高处自由落体状态撞击放有金属棒的电池表面。	No fire 不起火 No explosion, 不爆炸
7.7	External short circuit 外部短路	1.The battery should be in $20 \pm 5^\circ\text{C}$ environment temperature constant at 0.2C discharge exile to terminate with specified electrical voltage of 3.0 V. 2.Charge: according to 45°C high temperature and low temperature 10°C respectively, in the high or low temperature environment let stand 1-4 hours, according to the charging 0.2C to 4.25 V, until the charging current is reduced to 0.05 C. Remove the battery after charging temperature let stand for 1-2 hours. 3.External short circuit test: use an external resistor of $80 \pm 20\text{m}\Omega$ wire connected to the batteries extreme external short circuit, plus or minus in the test cell can maintain 24 hours or external temperature down to the most high temperature rise 20%, meet the one. 1.电池应在 $20 \pm 5^\circ\text{C}$ 的环境温度下以 0.2C 放电恒流放电至规定的终止电压 3.0V。 2.充电: 分别按高温 45°C 和低温 10°C 充电, 在高温或低温环境中静置 1-4 小时, 按 0.2C 充电至 4.25V, 直到充电电流减少到 0.05C 止. 充电完成后取出电池常温静置 1-2 小时。 3.外部短路测试: 用一外部电阻 $80 \pm 20\text{m}\Omega$ 的导线连接电芯的正负极端使其外部短路, 在试验中的电芯能维持 24 小时或外部温度下降到最高温升值的 20%, 满足其一即可。	No fire 不起火 No explosion 不爆炸

7.8	Internal short circuit 内部短路	<p>1.The battery should be in $20 \pm 5^{\circ}\text{C}$ environment temperature constant at 0.2C discharge exile to terminate with specified electrical voltage of 3.0 V.</p> <p>2.Charge:according to 45°C high temperature and low temperature10°C respectively, in the high or low temperature environment let stand 1-4 hours, according to the charging 0.2 C to 4.25 V, until the charging current is reduced to 0.05 C. Remove the battery after charging temperature let stand for 1-2 hours.</p> <p>3.Disassemble the battery and place the core of the nickel particle in the aluminum foil bag and then put it in the specified high temperature or low temperature box for 45 ± 5 minutes.</p> <p>4.Remove batteries from the sealed packaging, batteries voltage detection terminal and monitoring the surface temperature of thermocouple, put the batteries in extrusion equipment, placed the position of nickel particles on pressure head directly.</p> <p>5. Bottom surface of moving part of the press equipment is made of Nitrile rubber of Acryl. which is put on the 10mm*10mm stainless steel shaft. Nitrile rubber bottom surface is for cylindrical cell test. For prismatic test 5mm*5mm(2mm thickness) Acryl is put on the Nitrile rubber. The fixture is moved down at the speed of 0.1mm/S monitoring the cell voltage. when voltage drop caused by the internal short-circuit is detected, stop descent immediately and keep pressing jig in the position for 30S and then release the pressure. Volgtage is monitored more than 100 times per second and if voltage is dropped more than 50mV compare to the initial voltage, it is defined to internal short circuit has occurred. if the pressure reaches 800N for cylindrical cell and 400N for prismatic cell,stop descent immediately and then keep in the psition.</p> <p>1.电池应在 $20 \pm 5^{\circ}\text{C}$ 的环境下以 0.2C 放电恒流放电至规定的终止电压 3.0V。</p> <p>2.充电:分别按高温 45°C 和低温 10°C 充电,在高温或低温环境中静置 1-4 小时,按 0.2C 充电至 4.25V,直到充电电流减少到 0.05C 止.充电完成后取出电池常温静置 1-2 小时。</p> <p>3.拆解电池,把装有镍颗粒的电芯放在铝箔袋中,之后放入规定的高温或低温箱中 45 ± 5 分钟。</p> <p>4.将电芯从密封包装中取出,附上电压检测的端子和监测电芯表面温度的热电偶,把电芯放在挤压设备下,放置镍颗粒的位置对准压头正下方。</p> <p>5.内部短路.挤压设备的压头表面由丁腈橡胶或压克力制</p>	<p>No fire 不起火</p> <p>No explosion 不爆炸</p>
-----	--------------------------------	------------------------------------------------------------------------------------------------------------------------------------------------------------------------------------------------------------------------------------------------------------------------------------------------------------------------------------------------------------------------------------------------------------------------------------------------------------------------------------------------------------------------------------------------------------------------------------------------------------------------------------------------------------------------------------------------------------------------------------------------------------------------------------------------------------------------------------------------------------------------------------------------------------------------------------------------------------------------------------------------------------------------------------------------------------------------------------------------------------------------------------------------------------------------------------------------------------------------------------------------------------------------------------------------------------------------------------------------------------------------------------------------------------------------------------------------------------------------------------------------------------------------------------------------------------------------------------------------------------------------------------------------------------------------------------------------------------------------------------------------------------------------------------------------------------------------------------------------------------------------------------------------------------------------------------------------------------------------------------------------------------------------------------------------------------------------------------------------------------------------------------------------------------------------------------------------------------------------------------------------------------------------------------------------------------------------------------------------------------------------------------------	----------------------------------------------------

		<p>成,并固定在 10mm*10mm 的不锈钢轴上,圆柱形电芯测试用丁腈橡胶表面,菱形电芯的测试用丁腈橡胶表面再固定 2mm 厚 5mm*5mm 的压克力,压轴以 0.1mm/S 的速度下压,同时监测被测电芯电压,当内部短路造成电芯电压下降,立即停止下压并保持压轴静止 30S 之后,释放压力,下压的同时,以 100 次/S 的速度扫描电芯电压,当电芯电压比初始电压降低 50mV,判定为内部短路已发生。如果对圆柱形电芯的压力达到 800N 或对菱形电芯的压力达到 400N,停止下压并保持。</p>	
7.9	Thermal abuse 热滥用	<p>1.The battery should be in $20 \pm 5^\circ\text{C}$ environment temperature constant at 0.2C discharge exile to terminate with specified electrical voltage of 3.0 V. 2.Charge:according to 45°C high temperature and low temperature 10°C respectively, in the high or low temperature environment let stand 1-4 hours, according to the charging 0.2C to 4.25 V, until the charging current is reduced to 0.05 C. Remove the battery after charging temperature let stand for 1-2 hours. 3.Place the batteries in a gravity or circulating air convection oven, oven temperature by $5 \pm 2^\circ\text{C}/\text{min}$ speed up to $130 \pm 2^\circ\text{C}$, the battery needs to be placed in this environment for 30 min, the termination.</p> <p>1.电池应在 $20 \pm 5^\circ\text{C}$ 的环境温度下以 0.2C 放电恒流放电至规定的终止电压 3.0V。 2.充电:分别按高温 45°C 和低温 10°C 充电,在高温或低温环境中静置 1-4 小时,按 0.2C 充电至 4.25V,直到充电电流减少到 0.05C 止.充电完成后取出电池常温静置 1-2 小时。 3.将电芯放置在一个有引力或循环空气对流的烘箱中,烘箱的温度以 $5 \pm 2^\circ\text{C}/\text{min}$ 速度升至 $130 \pm 2^\circ\text{C}$, 电池需要放置在此环境中 30min, 试验终止。</p>	<p>No fire 不起火 No explosion 不爆炸</p>

※ Above testing of safe characteristic must be with protective equipment.(安全性能测试应在有保护措施下进行)

8. Protection Circuit 保护电路

8.1 PCM Standard

Item (项目)	Symbol (符号)	Content (详细内容)	Criterion (标准)
Over charge Protection (过充保护)	VDET1	Over charge detection voltage (过充电检测电压)	4.28±0.025V
	tVDET1	Over charge detection delay time (过充电检测延迟时间)	960~1400ms
	VREL1	Over charge release voltage (过充电解除电压)	4.08±0.05V
Over discharge protection (过放保护)	VDET2	Over discharge detection voltage (过放电检测电压)	3.0±0.05V
	tVDET2	Over discharge detection delay time (过放电检测延迟时间)	115~173ms
	VREL2	Over discharge release voltage (过放解除电压)	3.0±0.05V
	IDP	Over current detection current (过电流保护电流)	5~11A
	tVDET3	Detection delay time (检测延迟时间)	7.2~11ms
			Release condition (保护解除条件)
Short protection (短路保护)		Detection condition (保护条件)	Exterior short circuit (外部电路短路)
	TSHORT	Detection delay time (检测延迟时间)	150~540uS
		Release condition (保护解除条件)	Cut short circuit (断开短路电路)
Interior resistance (内阻)	RDS	Main loop electrify resistance (主回路通态电阻)	VC=4.2V,RDS≤70mΩ
Current consumption (消耗电流)	IDD	Current consume in normal operation (工作时电路内部消耗)	3.5 μ A Type 7.0 μ A Max

8.2 BOM For PCM 保护板物料清单

NO.	Location 元件编号	Part name 元件名称	Specification 元件规格	Packtype 封装形式	Q'ty 数量	Remark 备注
1	U1	Protection IC	S-8261DAI	SOT-23-6	1	
2	U2 U3	MOSFET	8205A	SOT-23-6	2	
3	R1	Resistance	330 Ω \pm 5%	0603	1	
4	R2	Resistance	470 Ω \pm 5%	0603	1	
5	R3	Resistance	10K Ω \pm 5% B=3435	0603	1	
6	C1	Capacitance	0.1 μ F	0402	1	
7	PCB	Print circuit board	0.8*5.3*34.7mm	/	1	

8.3 Schematic diagram 原理图

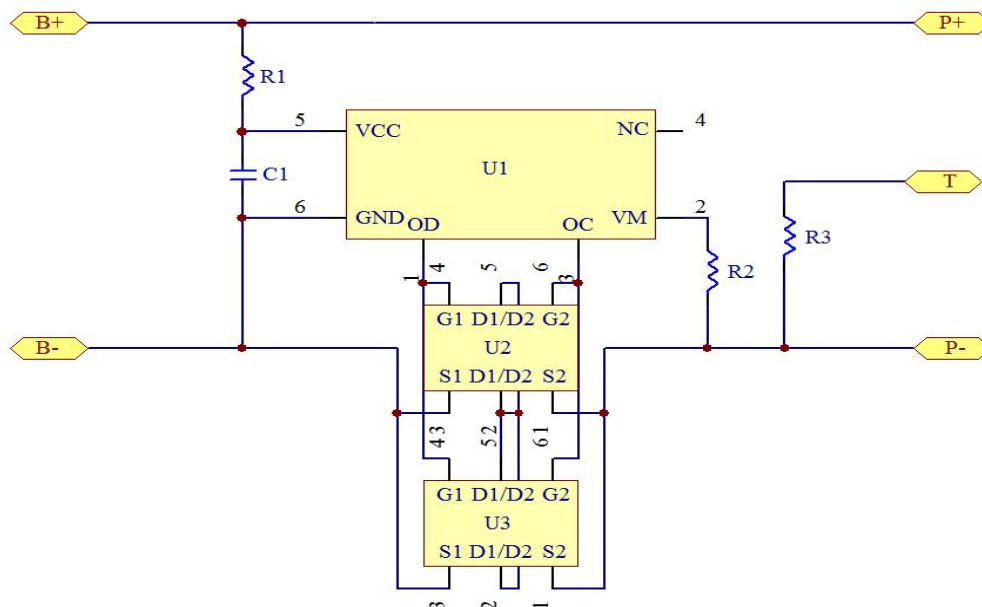

9. Warnings 警告

To prevent the possibility of the pack from leaking, heating, fire .please observe the following precautions:

☆为防止电池组合可能发生的泄漏,发热,起火,请注意以下预防措施:

The soft aluminum packing foil is very easily damaged by sharp edge parts such as Ni-tabs, pins and needles .Do not strike at pack with any sharp edge parts.

☆ 电池组合外包装膜易被镍片,尖针等尖锐部件损伤,禁止用尖锐部件碰伤电池。

Do not immerse the pack in water and seawater.

☆ 严禁将电池组合浸入海水或水中。

Do not use and leave the pack near a heat source as fire or heater.

☆ 禁止将电池组合在热高温源旁,如火,加热器等使用设备。

When recharging, use the battery charger specifically for that purpose.

☆ 充电时请选用锂离子电池专用充电器。

Do not reverse the positive and negative terminals.

☆ 禁止颠倒正负极使用电池组合。

Do not connect the pack to an electrical outlet.

☆ 禁止将电池组合直接接入电源插座。

Do not discard the pack in fire or heat it.

☆ 禁止将电池组合丢入火或加热器中。

Do not short-circuit the pack by directly connecting the positive and negative terminal with metal object such as wire.

☆ 禁止用金属直接将电池组合的正负极进行短路连接。

Do not transport and store the battery together with metal objects such as necklaces, hairpins etc.

☆ 禁止将电池组合与金属如发夹、项链等一起运输或贮存。

Do not strike or throw the pack.

☆ 禁止敲击或抛掷,踩踏电池组合等。

Do not directly solder the pack or battery and pierce the battery with a nail or other sharp object.

☆ 禁止直接焊接电池组合或电芯,禁止用钉子或其它利器刺穿电池组合或电芯。

10. Cautions 注意

Do not use or leave the pack at very high temperature (for example, at strong direct sunlight or a vehicle in extremely hot conditions). Otherwise, it can overheat or fire or its performance will be degenerate and its service life will be decreased.

△ 禁止在高温下(直热的阳光下或很热的汽车中)使用或放置电池组合,否则可能会引起电池过热,起火或功能失效,从而导致电池组合寿命减短。

Do not use it in a location where static electricity is great, otherwise, the safety devices in the pack may be damaged, which will cause hidden trouble of safety.

△ 禁止在强静电和强磁场的地方使用,否则易破坏电池组合的安全保护装置,带来安全隐患。

If the pack leaks and the electrolyte get into the eyes, do not rub eyes, instead, rinse the eyes, with clean running water, and immediately seek medical attention. Otherwise, eye injury can result.

△ 如果电池发生泄漏,电解液进入眼睛,请不要揉擦,应用清水冲洗眼睛,并立即送医院治疗,否则会伤害眼睛。

If the pack takes off an odor, generates heat, becomes discolored or deformed, or in any way appear abnormal during use, recharging or storage, immediately remove it from the device or battery charge and stop using it.

△ 如果电池组合在使用或贮存中发出异味,发热,变色,变形,或者是在充电过程中出现任何异常现象,立即将电池从充电器或装置中移开,并停止使用。

In case the pack terminals are dirt, clean the terminals with a dry cloth before use. Otherwise power failure or charge failure may occur due to the poor connection with the instrument.

△ 如果电池组合的连接点弄脏,使用前应用干布擦净,否则可能会因接触不良而影响性能失效。

Be aware discharged battery may cause fire or smoke, tape the terminals to insulate them.

△ 废弃电池应用绝缘纸包住电池极性,以防起火,冒烟。

The pack should be stored at room temperature, charged to about 40% to 60% of capacity. In case of over-discharge, pack should be charged for one time every 3 months while storing and batteries should be discharge and charge after being stored more than a year in order to activate it and restore energy.

△ 电池组合应当在室温下存放,应充到 40%至 60%的电量。为防止电池过放,建议每 3 个月进行一次充电,如储存时间超过一年,建议每年进行一次充、放电以激活电池性能。

11. Notice for Design of Battery Pack 电池外壳设计注意事项

11.1 Pack toughness (外壳坚韧度)

Battery pack should have sufficient strength and the cell inside should be protected from mechanical shocks.
电池外壳应该有足够的机械强度使聚合物电池免受机械撞击。

11.2 Cell fixing (电池的固定)

The cell should be fixed to the battery pack by its large surface area. No cell movement in the battery pack should be allowed.

电池最大面积的一面应该固定在外壳上,安装后电池不能有松动。

11.3 Inside design (外壳内部设计)

No sharp edge components should be insides the pack containing the cell.

外壳内安装电池的部位不应有锋锐边。

11.4 Tab connection (极片连接)

Ultrasonic welding or spot welding is recommended for tab connection method. Battery pack should be designed that shear force are not applied to the tabs. If apply manual solder method to connect tab with PCM, below notice is very important to ensure battery performance:

- The solder iron should be temperature controlled and ESD safe;
- Soldering temperature should not exceed 350°C;
- Soldering time should not be longer than 3s;
- Soldering times should not exceed 5 times, Keep battery tab cold down before next time soldering;
- Directly heat cell body is strictly prohibited, Battery may be damaged by heat above approx. 100°C

建议使用超声波或点焊焊接方法;外壳设计应使极片不受外力。

如果使用人工焊接保护板,下面的注意事项对于确保电池性能非常重要:

- 焊接铬铁的温度必须可控且可防静电;
- 焊接时铬铁的温度不能超过 350°C;
- 焊锡时间不能超过 3 秒钟;
- 焊锡次数不能超过 5 次,待极片冷却后才能进行下一次焊锡;
- 严禁直接加热电芯,高于 100°C 度会损害电芯。

12. Handling of Battery 电池操作注意事项

12.1 .Soft Aluminum foil (铝箔软包装)

Easily damaged by sharp edge parts such as pins and needles, Ni-tabs, comparing with metal-can-cased .
相对于金属壳的方形电池,铝箔软包装比较容易被锐利部件刺损,如针尖、镍带。

△ Don't strike battery with any sharp edge parts 勿用尖锐处撞击电池。

△ Trim your nail or wear glove before taking battery 剪掉指甲,或者戴手套。

△ Clean worktable to make sure no any sharp particle 清理工作台,避免尖锐零部件。

12.2. Sealed edge may be damaged by heat above 100°C, bend or fold sealed edge.

封边被加热到 100°C 以上以及弯折封边都容易使封边受损。

12.3. Prohibition short circuit (禁止电池短路)

Never make short pack circuit. It generates very high current which causes heating of the cells and may cause electrolyte leakage, gassing or explosion that are very dangerous. The tabs may be easily short-circuited by putting them on conductive surface. Such outer short circuit may lead to heat generation and damage of the cell.

避免电池短路。短路会产生很高的电流而使电池发热以及电解液泄漏，产生气体或爆炸是非常危险的。极片连接在导电物体表面很容易短路，外部短路会导致发热及损害电池。

12.4.Mechanical shock (机械撞击)

△Cells have less mechanical endurance than metal-can-cased.

△Falling, hitting, bending, etc. may cause degradation of characteristics.

聚合物电池比金属壳方形电池的机械耐久性更小。

跌落、碰撞、弯曲等等都可能会降低聚合物电池的性能。

13.Period of Warranty 保质期

The period of warranty is one year from the date of shipment. YJ Power guarantees to give a replacement in case of battery with defects proven due to manufacturing process instead of the customer abuse and misuse.

电池的保质期从出货之日算起为一年。如果证明电池的缺陷是在我们公司制造过程中造成的而不是客户滥用或错误使用造成，本公司负责退换电池。

14. Others 其它事项

14.1.The customer is requested to contact YJ Power in advance, if and when the customer needs other applications or operating conditions than those described in this document. Additional experimentation may be required to verify performance and safety under such conditions.

客户若需要将电池用于超出文件规定以外的应用，或在文件规定以外的使用条件下使用电池，应事先联系言九公司，因为需要进行特定的实验测试以核实电池在该使用条件下的性能及安全性。

14.2. YJ Power will take no responsibility for any accident when the battery is used under other conditions than those described in this Document.

对于在超出文件规定以外的条件下使用电池而造成的任何意外事故，言九公司概不负责承担任何责任。

14.3. YJ Power will inform, in a written form, the customer of improvement(s) regarding proper use and handing of the battery, if it is deemed necessary.

如有必要，言九公司会以书面形式告之客户有关正确操作使用电池的改进措施。

14.4. Any matters that this specification does not cover should be conferred between the customer and YJ Power.

任何本规格书中未提及的事项，须经双方协商确定。

The contents of this document are not allowed to be used in whole or in part without the written consent of YJ Power,so please keep it strictly confidential.

本文件内容未经言九公司书面同意许可，请严格保密，不允许全部或部分使用。

15. Package sketch map 包装示意图

/

YJ Power

YJ Power

YJ Power