



Air-Operated 5:1 Oil Pump

With Extension Kit – 6.6 GPM

Owner's Manual



! WARNING: Read carefully and understand all ASSEMBLY AND OPERATION INSTRUCTIONS before operating. Failure to follow the safety rules and other basic safety precautions may result in serious personal injury.

Item #58257

READ & SAVE THESE INSTRUCTIONS

Thank you very much for choosing an Ironton™ product!

For future reference, please complete the owner's record below:

Serial Number/Lot Date Code: _____

Purchase Date: _____

Save the receipt, warranty, and this manual. It is important that you read the entire manual to become familiar with this product before you begin using it.

This product is designed for certain applications only. Northern Tool and Equipment is not responsible for issues arising from modification or improper use of this product such as an application for which it was not designed. We strongly recommend that this product not be modified and/or used for any application other than that for which it was designed.

For technical questions, please call **1-800-222-5381**.

Table of Contents

Intended Use.....	4
Packaging Contents.....	4
Technical Specifications	4
Important Safety Information	5
Specific Operation Warnings	7
Main Parts of Pump.....	8
Assembly Instructions.....	9
Before Each Use.....	12
Operating Instructions.....	13
After Each Use.....	13
Maintenance	14
Troubleshooting.....	14
Parts Diagram.....	15
Parts List.....	16
Replacement Parts	17
Limited Warranty.....	18

Intended Use

The Ironton Air-Operated 5:1 Oil Pump with Extension Kit can be used to transfer lubrication oil, waste oil, and antifreeze liquids.

Packaging Contents

Part#	Description	Quantity
1701054	5:1 Air-Operated Oil Pump	1
ET10000	Extension Tube	1

Technical Specifications

Compression Ratio	5:1
Operating Pressure (psi)	70-115
Max. Fluid Pressure (psi)	580
Air Consumption (min)	115 psi/6.5 CFM
Capacity (gallon/min)	6.6
Tube Diameter (inch)	1 5/8 Inches
Suction Tube Length (inch)	10-5/8", Wall installed / Extension Transfer
Air Inlet Connection	¼ Inches NPT Female
Oil Delivery Connection	Male ¾ Inches
Max. Viscosity Oil Delivered	SAE 240
Temperature Oil Delivered	-50-122°F
Noise Level (dB)	82

Important Safety Information

⚠WARNING

- Read and understand all instructions. Failure to follow all instructions may result in serious injury or property damage.
- The warnings, cautions, and instructions in this manual cannot cover all possible conditions or situations that could occur. Exercise common sense and caution when using this tool. Always be aware of the environment and ensure that the tool is used in a safe and responsible manner.
- Do not allow persons to operate or assemble the product until they have read this manual and have developed a thorough understanding of how it works.
- Do not modify this product in any way. Unauthorized modification may impair the function and/or safety and could affect the life of the product. There are specific applications for which the product was designed.
- Use the right tool for the job. DO NOT attempt to force small equipment to do the work of larger industrial equipment. There are certain applications for which this equipment was designed. This product will be safer and do a better job at the capacity for which it was intended. DO NOT use this equipment for a purpose for which it was not intended.
- Industrial or commercial applications must follow OSHA requirements.

⚠WARNING

WORK AREA SAFETY

- Inspect the work area before each use. Keep work area clean, dry, free of clutter, and well-lit. Cluttered, wet, or dark work areas can result in injury. Using the product in confined work areas may put you dangerously close to cutting tools and rotating parts.
- Do not use the product where there is a risk of causing a fire or an explosion; e.g., in the presence of flammable liquids, gases, or dust. The product can create sparks, which may ignite the flammable liquids, gases, or dust.
- Do not allow the product to come into contact with an electrical source. The tool is not insulated and contact will cause electrical shock.
- Keep children and bystanders away from the work area while operating the tool. Do not allow children to handle the product.
- Be aware of all power lines, electrical circuits, water pipes, and other mechanical hazards in your work area. Some of these hazards may be hidden from your view and may cause personal injury and/or property damage if contacted.

⚠WARNING

PERSONAL SAFETY

- Stay alert, watch what you are doing, and use common sense when operating the tool. Do not use the tool while you are tired or under the influence of drugs, alcohol, or medication. A moment of in-

attention while operating the tool may result in serious personal injury.

- Dress properly. Do not wear loose clothing, dangling objects, or jewelry. Keep your hair, clothing and gloves away from moving parts. Loose clothes, jewelry, or long hair can be caught in moving parts. Air vents on the tool often cover moving parts and should be avoided.
- Wear the proper personal protective equipment when necessary. Use ANSI Z87.1 compliant safety goggles (not safety glasses) with side shields, or when needed, a face shield. Use a dust mask in dusty work conditions. Also use non-skid safety shoes, hardhat, gloves, dust collection systems, and hearing protection when appropriate. This applies to all persons in the work area.
- Do not overreach. Keep proper footing and balance at all times.
- Remove keys or wrenches before connecting the tool to an air supply, power supply, or turning on the tool. A wrench or key that is left attached to a rotating part of the tool may cause personal injury.
- Secure the work with clamps or a vise instead of your hand when practical. This safety precaution allows for proper tool operation using both hands.

⚠ CAUTION

PUMP USE AND CARE

- Do not force the pump. Products are safer and do a better job when used in the manner for which they are designed. Plan your work, and use the correct product for the job.
- Check for damaged parts before each use. Carefully check that the product will operate properly and perform its intended function. Replace damaged or worn parts immediately. Never operate the product with a damaged part.
- Do not use a product with a malfunctioning switch. Any power tool that cannot be controlled with the power switch is dangerous and must be repaired by an authorized service representative before using.
- Disconnect the power/air supply from the product and place the switch in the locked or off position before making any adjustments, changing accessories, or storing the tool. Such preventive safety measures reduce the risk of starting the tool accidentally.
- Store the pump when it is not in use. Store it in a dry, secure place out of the reach of children. Inspect the tool for good working condition prior to storage and before re-use.
- Use only accessories that are recommended by the manufacturer for use with your product. Accessories that may be suitable for one product may create a risk of injury when used with another tool. Never use an accessory that has a lower operating speed or operating pressure than the tool itself.
- Keep guards in place and in working order. Never operate the product without the guards in place.
- Do not leave the tool running unattended.

Specific Operation Warnings

⚠WARNING

- To prevent serious injury or property damage, read and understand owner's manual before operating.
- Wear ANSI Z87.1 compliant goggles and other protective gear while operating.
- Do not exceed the maximum working air pressure of 115 PSI.
- Never point the dispenser at people or animals.
- Do not use the pump near open flames. Do not smoke during this operation.
- When not in use, disconnect the air supply air to the pump.
- Inspect before each use; check that all connections are tight and secure.
- Never use if parts are damaged or broken; replace damaged or broken parts before operating.
- Use only original parts when repairing the pump.
- Always disconnect the air supply after use so that oil can't leak out in case one of the pump's components should break.
- The compressed air must be filtered to avoid dust and moisture into pump.
- Do not use with any liquid besides the intended oil, lubricants, or antifreeze liquids. See owner's manual for intended oil.
- Disconnect air hose and relieve air pressure before servicing.
- Always dispose of oil and other liquids according to local waste authority guidelines.
- Not for use by or around children.

Main Parts of Pump

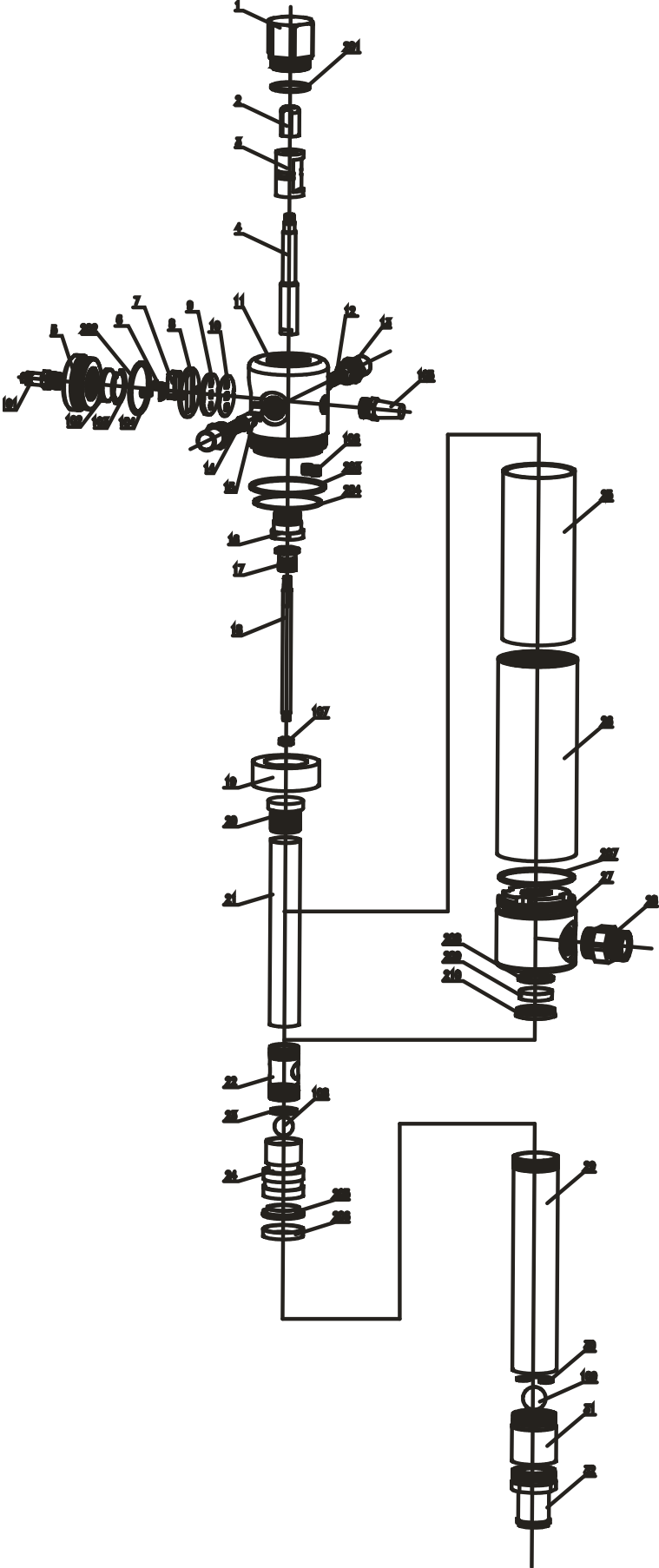

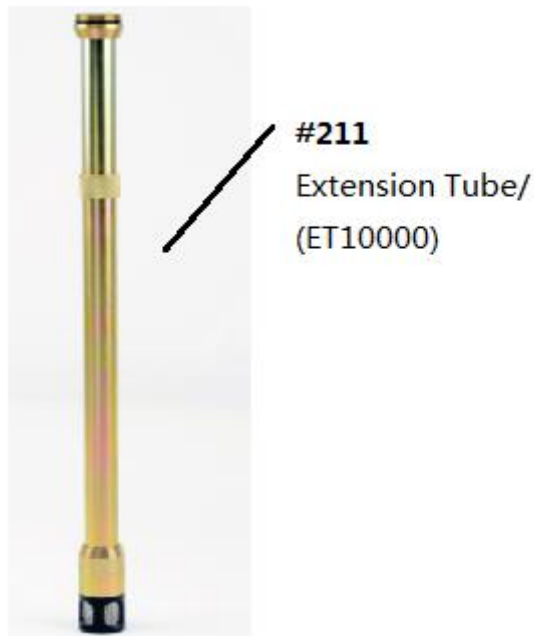

Assembly Instructions

DIRECTLY FIT PUMP INTO DRUM

- Insert the suction tube of pump into the drum and secure with ring nut, suitable for commercial drums with 57 diameter hole and threading 2" BSP.
- Fit an oil delivery tube for the oil outlet using only high quality tubes (normally 1/2" or 3/4", according to DIN-SAE norms), by means of 1/2" BSP threading fitting.
- Oil delivery pistol: Connect delivery tube with delivery pistol using suitable pipe fittings, and point the pistol at the desired area.
- Air inlet connection is 1/4" quick plug (or 1/4" NPT female) in all versions.
- Compressed air connection (to be supplied by the customer) should be done using suitable tubes.
- A pressure regulator should be used to keep the pump's working pressure at the best possible level (max 5-8 bar) between the pump and the compressed air line.
- A cut-off switch can enable the operator to stop the pump at any given moment by cutting the air supply off between the pump and the compressed air line.
- Switch on all switches.

WALL INSTALLED

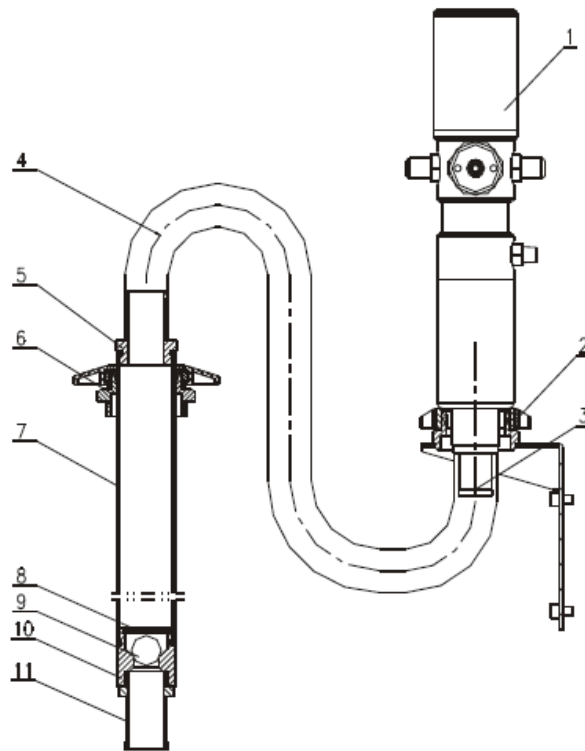

Part#	Description	Quantity	Part#	Description	Quantity
1	Oil pump	1	7	Rigid suction tube	1
2	Wall bracket	1	8	Spring circlip	1
3	Pump adapter	1	9	Ball	1
4	Flexible suction hose	1	10	Valve seat	1
5	Suction hose adapter	1	11	Filter	1
6	Bung adapter	1			

1. Secure the bracket to the wall using the dowels at about 1200mm height appropriate for the tank's dimensions. Make sure that the wall is solid and thick enough for the dowels. Do not interfere with hydraulic tubes or electric lines.
2. Secure the pump to the bracket 2.
3. Connect the flexible suction tube 4 to the pump using the clamp provided.
4. Connect the rigid suction 7 to the end of the flexible suction tube 4 using the elastic clamp provided.
5. Put the bung adapter 6 into the drum hole.
6. Put the rigid suction tube 7 into the pump and secure it in place.

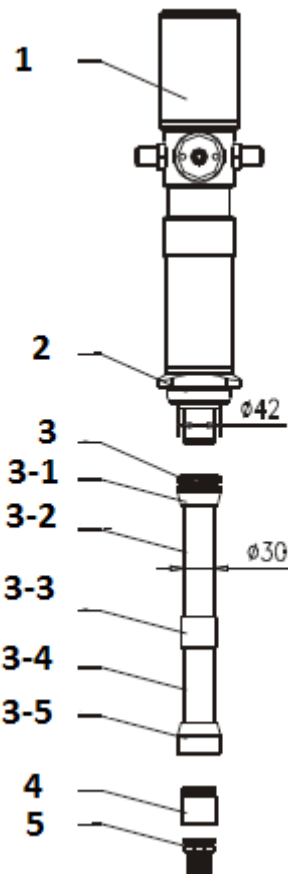

Part#	Description	Quantity	Part#	Description	Quantity
1	Oil pump	1	3-4	Extension 200mm tube	1
2	Bung adapter	1	3-5	Foot connection	1
3-1	Top connection	1	4	Foot valve	1
3-2	Extension 500mm	1	5	Filter	1
3-3	Extension sleeve	1			

- Depending on the length of the suction tube, determine the desired extension length (see the examples).
- Remove filter and foot valve from the stub pump, screw the extension tube on (with top connection), then screw filter and foot valve on the extension tube (foot connection end).

Note: 1:1 stub pump's adapter is different than with others.

CONNECT THE PUMP WITH OTHER ACCESSORIES

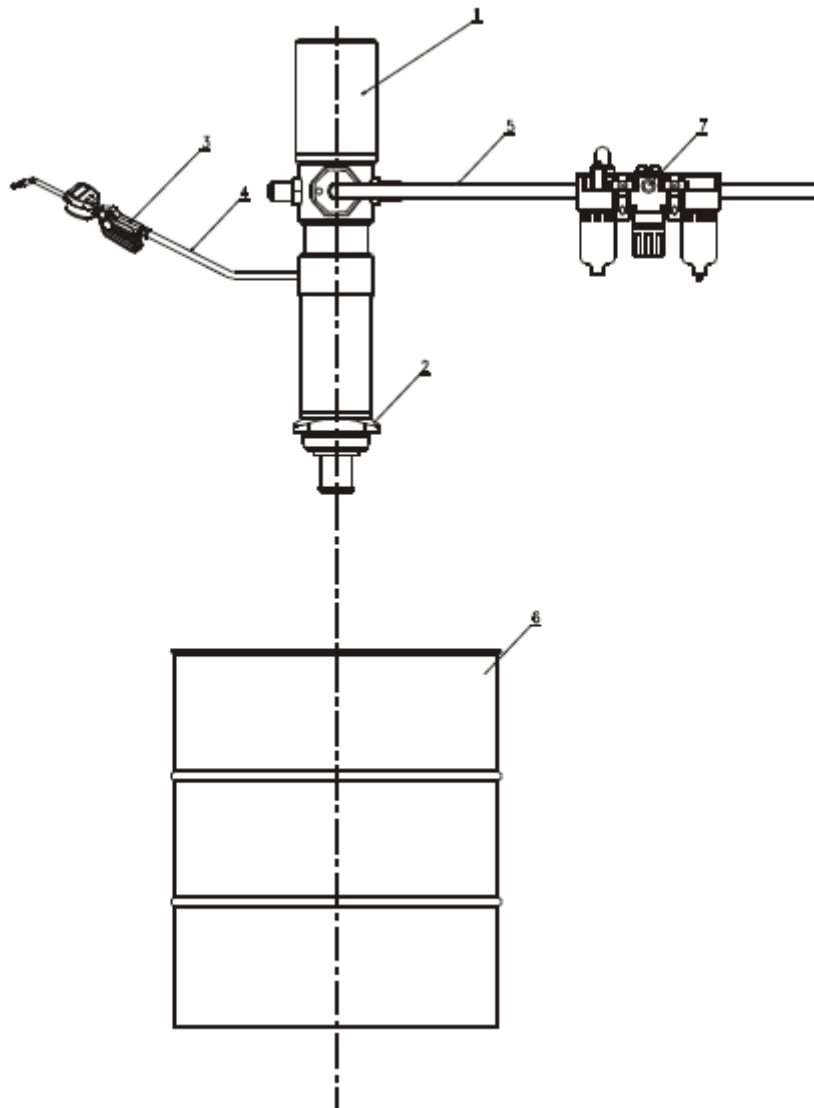

Part#	Description
1	Oil pump
2	Bung adapter
3	Oil pistol
4	Hose with fitting
5	Air hose with quick coupling
6	Drum
7 (7-1, 7-2, 7-3)	Filter, pressure regulator, and lubricator

Before Each Use

⚠WARNING

- Inspect before each use; check that all connections are tight and secure.
- Never use if parts are damaged or broken; replace damaged or broken parts before operating.
- Disconnect air hose and relieve air pressure before servicing.

Operating Instructions

⚠WARNING

- Wear ANSI Z87.1 compliant goggles and other protective gear while operating.
- Do not exceed the maximum working air pressure of 115 PSI.
- Never point the dispenser at people or animals.
- Do not use the pump near open flames. Do not smoke during this operation.
- The compressed air must be filtered to avoid dust and moisture into pump.
- Do not use with any liquid besides the intended oil, lubricants, or antifreeze liquids. See owner's manual for intended oil.

PUMP OPERATION

If the pump has already been primed and the compressed air feed is connected to the appropriate work pressure level (70-115 PSI), the pump will start automatically when the nozzle or gun situated at the end of the grease delivery circuit is opened.

To stop the pump, simply close the nozzle or disconnect the air inlet line.

PRESSURE RELIEF PROCEDURE

To reduce the risk of serious bodily injury, always follow the following procedures whenever you shut off the pump, check or service any part of the spray/dispensing system, install, clean, or change spray tips/nozzles, and whenever you stop spraying/dispensing:

1. Shut off the air to the pump.
2. Point grease gun outlet into a container and trigger the grease gun to relieve pressure.

After Each Use

⚠WARNING

- Always disconnect the air supply after use so that oil can't leak out in case one of the pump's components should break.
- Pumps are delivered in appropriate cardboard boxes. Packaging material should be properly disposed.
- Handling and storage of the new pump do not require any special procedures. However after the pump has been used, empty the used oil in the suction tube into an appropriate container. This is done by over-turning the pump.
- The dust in compressed air can slow down and even block the motor cylinder. The following steps may prevent this from happening:
 - Add 50 grams of appropriate lubricating oil to the air inlet hole weekly; operate the pump for several minutes after adding oil.
 - Turn on the pump for several minutes until moving parts are fully lubricated.
 - You may repeat the above operation if necessary.
 - The above steps should be carried out on a weekly base.

- For the pumps that are attached with compressed air treatment equipment empty the water retained in the reservoir of the filter-purger frequently.
- For the pumps that are attached with a lubricator, please pay close attention to the lubricator's oil level and refill with SAE 20, SAE 30 or antifreeze oil for extreme conditions when necessary.

Maintenance

- The user should perform only routine maintenance operations (filters, silencers, cleaning) in order to avoid damaging the unit or compromising his or her safety.
- Contact our sales or service centers when the pump needs further maintenance.

Troubleshooting

Problem	Possible Causes	Solutions
The pump continues to operate after the gun trigger has been released.	<ol style="list-style-type: none"> 1. There is an oil leak at some point in the circuit. 2. Valve sets (part# 24, 208, 209, 210, 205, 206) close incorrectly due to dirt or wearing. 	<ol style="list-style-type: none"> 1. Check and tighten connections. Repair the leak. 2. Have damaged parts replaced.
Reduction of the oil delivery or reduced pressure in the oil delivery.	<ol style="list-style-type: none"> 1. Silencer (105) is dirtied. 2. Blocked at some point in the oil circuit. 3. Ball valve set (31, 109) closes incorrectly due to dirt or wearing. 	<ol style="list-style-type: none"> 1. Clean or recharge silencer. 2. Use clean oil. 3. Have damaged parts replaced.
Air loss through the air exhaust.	<ol style="list-style-type: none"> 1. The sliding valve (7) does not close properly. 2. Broken press piece (6). 3. Damaged O-ring (203,204). 4. Damaged piston (19). 5. Broken spring (12). 	<ol style="list-style-type: none"> 1. Disassemble and clean. Replace in case of damage. 2. Have damaged parts replaced.
Oil leaks through the air exhaust.	Seal set (208, 210) is damaged.	Have damaged parts replaced.

Parts Diagram

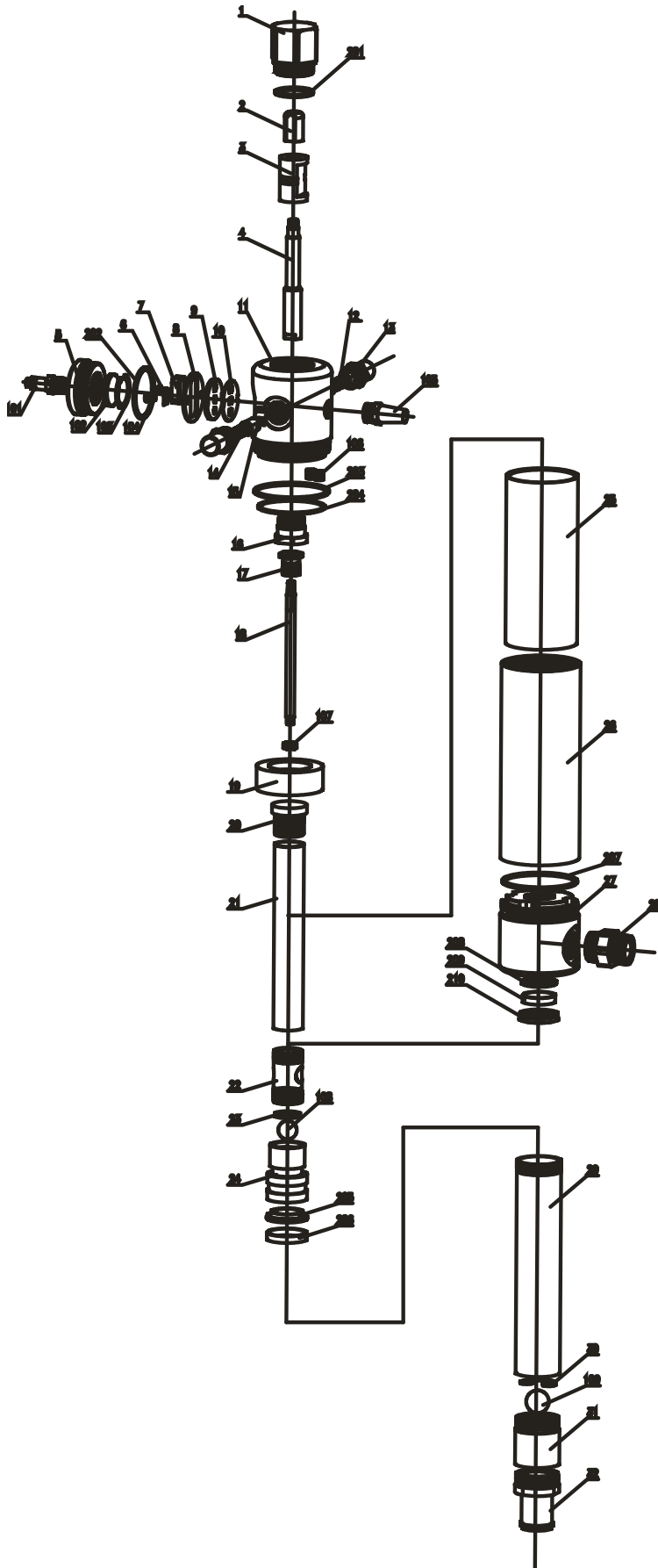



#211
 Extension Tube/
 (ET10000)

Parts List

Part#	Description	Quantity
1	Air motor cover	1
2	Air motor shell inside	1
3	Slider	1
4	Bracket	1
5	Air center cover	1
6	Press piece	1
7	Slider	1
8	Securing washer	1
9	Gasket	1
10	Soft gasket	1
11	Air control center	1
12	Spring	2
13	Spring shell	2
14	Spring seat	2
15	Trip shoe guide	2

Part#	Description	Quantity
27	Side cover	1
28	Outlet	1
29	Suction tube	1
30	Spring circlip	1
31	Valve seat	1
32	Filter	1
101	Quick coupling	1
102	Silencer	1
103	Small circlip	1
104	Screw	2
105	Silencer	1
106	Screw	1
107	Nut	1
108	Ball	1
109	Ball	1

16	Bracket	1
17	Screw	1
18	Shaft	1
19	Piston	1
20	Piston connect cover	1
21	Piston shaft	1
22	Piston stem	1
23	Baffle	1
24	Small piston	1
25	Piston cover	1
26	Cut cover	1

201	O-ring	1
202	O-ring	1
203	O-ring	1
204	O-ring	1
205	U seal	1
206	Guiding	1
207	O-ring	1
208	O-ring	1
209	Guiding	1
210	U-ring	1
211	Extension tube (ET10000)	1

Replacement Parts

- For replacement parts and technical questions, please call Customer Service at **1-800-222-5381**.
- Not all product components are available for replacement. The illustrations provided are a convenient reference to the location and position of parts in the assembly sequence.
- When ordering parts, the following information will be required: item description, item model number, item serial number/item lot date code, and the replacement part reference number.
- The distributor reserves the rights to make design changes and improvements to product lines and manuals without notice.

Limited Warranty

Northern Tool and Equipment Company, Inc. ("We" or "Us") warrants to the original purchaser only ("You" or "Your") that the Ironton product purchased will be free from material defects in both materials and workmanship, normal wear and tear excepted, for a period of **90 days** from date of purchase. The foregoing warranty is valid only if the installation and use of the product is strictly in accordance with product instructions. There are no other warranties, express or implied, including the warranty of merchantability or fitness for a particular purpose. If the product does not comply with this limited warranty, Your sole and exclusive remedy is that We will, at our sole option and within a commercially reasonable time, either replace the product or product component without charge to You or refund the purchase price (less shipping). This limited warranty is not transferable.

Limitations on the Warranty

This limited warranty does not cover: (a) normal wear and tear; (b) damage through abuse, neglect, misuse, or as a result of any accident or in any other manner; (c) damage from misapplication, overloading, or improper installation; (d) improper maintenance and repair; and (e) product alteration in any manner by anyone other than Us, with the sole exception of alterations made pursuant to product instructions and in a workmanlike manner.

Obligations of Purchaser

You must retain Your product purchase receipt to verify date of purchase and that You are the original purchaser. To make a warranty claim, contact Us at 1-800-222-5381, identify the product by make and model number, and follow the claim instructions that will be provided. The product and the purchase receipt must be provided to Us in order to process Your warranty claim. Any returned product that is replaced or refunded by Us becomes our property. You will be responsible for return shipping costs or costs related to Your return visit to a retail store.

Remedy Limits

Product replacement or a refund of the purchase price is Your sole remedy under this limited warranty or any other warranty related to the product. We shall not be liable for: service or labor charges or damage to Your property incurred in removing or replacing the product; any damages, including, without limitation, damages to tangible personal property or personal injury, related to Your improper use, installation, or maintenance of the product or product component; or any indirect, incidental or consequential damages of any kind for any reason.

Assumption of Risk

You acknowledge and agree that any use of the product for any purpose other than the specified use(s) stated in the product instructions is at Your own risk.

Governing Law

This limited warranty gives You specific legal rights, and You also may have other rights which vary from state to state. Some states do not allow limitations or exclusions on implied warranties or incidental or consequential damages, so the above limitations may not apply to You. This limited warranty is governed by the laws of the State of Minnesota, without regard to rules pertaining to conflicts of law. The state courts located in Dakota County, Minnesota shall have exclusive jurisdiction for any disputes relating to this warranty.



Distributed by:

Northern Tool & Equipment Company, Inc.

Burnsville, Minnesota 55306

www.northerntool.com

Made in China