

JCR2

Self-priming "JET" pumps

-  Clean water
-  Domestic use
-  Civil use



PERFORMANCE RANGE

- Flow rate up to **18.49** US g.p.m.
- Head up to **213 feet**

APPLICATION LIMITS

- Manometric suction lift up to **29.52 feet** (HS)
- Liquid temperature between **14 °F** and **104 °F**
- Ambient temperature up to **104 °F**
- Max. working pressure **6 bar**
- Continuous service **S1**

CONSTRUCTION AND SAFETY STANDARDS

EN 60335-1
IEC 60335-1
CEI 61-150

EN 60034-1
IEC 60034-1
CEI 2-3



CERTIFICATIONS

Company with management system certified DNV
ISO 9001: QUALITY
ISO 14001: ENVIRONMENT

INSTALLATION AND USE

Suitable for use with clean water and with liquids that are not chemically aggressive towards the materials from which the pump is made. The self-priming **JCR** pumps are designed to pump water even in cases where air is present. As a result of their reliability and the fact that they are easy to use, they are recommended for use in domestic applications such as the distribution of water in combination with small or medium sized pressure tanks, and for the irrigation of gardens and orchards, etc. The pump should be installed in an enclosed environment or sheltered from inclement weather.

PATENTS - TRADE MARKS - MODELS

- European Patent n. 1 510 696

OPTIONS AVAILABLE ON REQUEST

- Pump body with NPT ANSI B 1.20.1 threaded ports
- Other voltages

GUARANTEE

2 years subject to terms and conditions

CHARACTERISTIC CURVES AND PERFORMANCE DATA

60 Hz n= 3450 rpm HS= 0 m

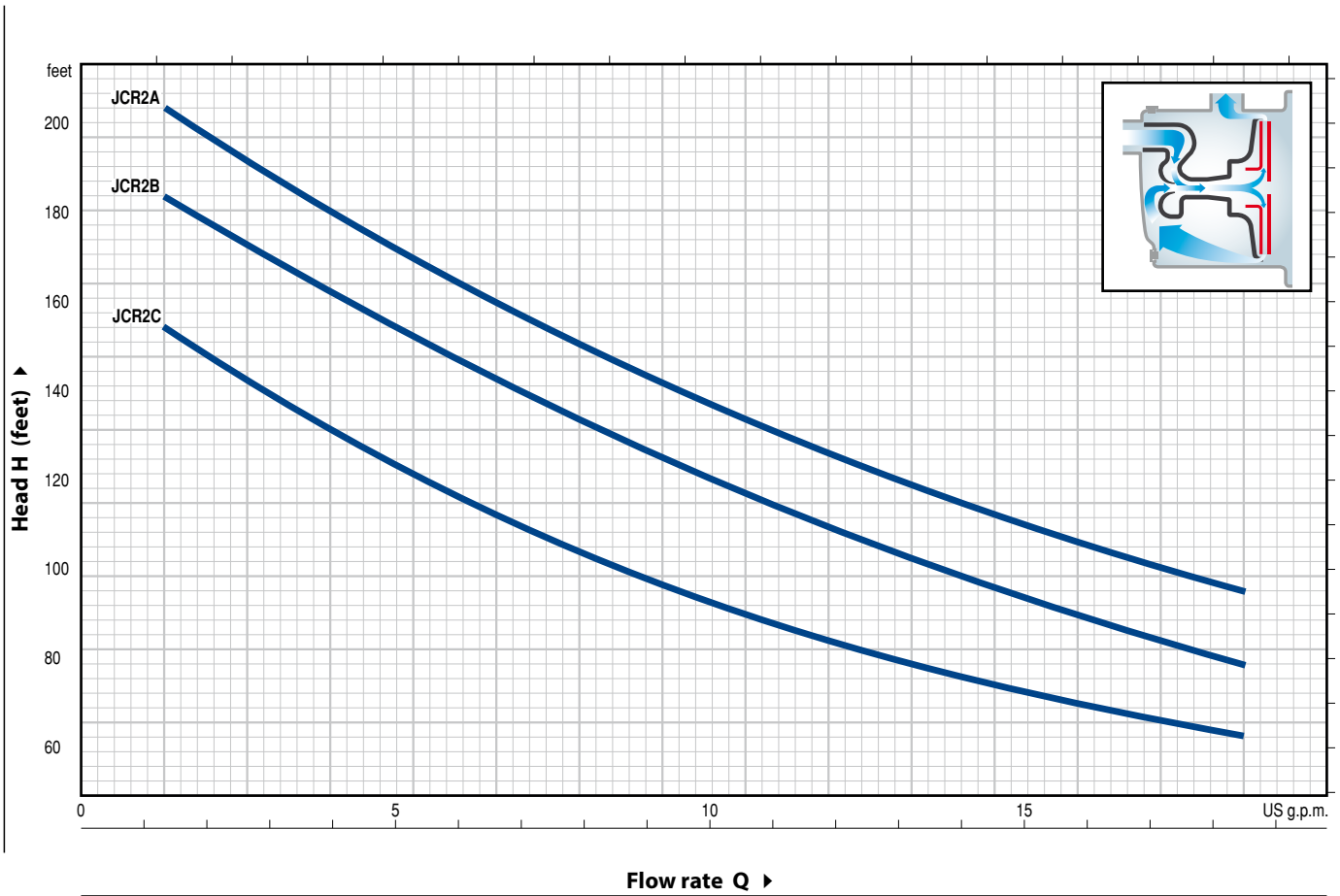

MODEL		POWER (P ₂)		Q US g.p.m				
Single-phase	Three-phase	kW	HP	0	5	10	20	
JCRm 2C	JCR 2C	0.75	1	H metres	164	154	141	121
JCRm 2B	JCR 2B	0.90	1.25		196	183	173	152
JCRm 2A	JCR 2A	1.1	1.5		213	203	190	169

Q = Flow rate H = Total manometric head HS = Suction height

Tolerance of characteristic curves in compliance with EN ISO 9906 Grade 3B.

STANDARD INSTALLATION

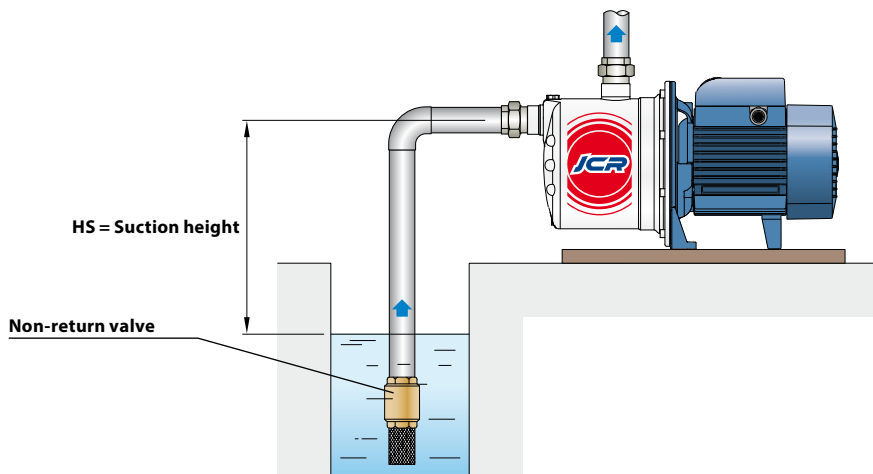

POS. COMPONENT CONSTRUCTION CHARACTERISTICS

1	PUMP BODY	Stainless steel AISI 304 complete with threaded ports in compliance with ISO 228/1				
2	BODY BACKPLATE	Stainless steel AISI 304				
3	NOZZLE ASSEMBLY	Noryl FE1520PW				
4	IMPELLER	Stainless steel AISI 304				
5	MOTOR SHAFT	Stainless steel EN 10088-3 - 1.4104				
6	MECHANICAL SEAL	<i>Seal Model</i>	<i>Shaft Diameter</i>	<i>Stationary ring</i>	<i>Materials Rotational ring</i>	<i>Elastomer</i>
		AR-14	Ø 14 mm	Ceramic	Graphite	NBR
7	BEARINGS	6203 ZZ / 6203 ZZ				
8	CAPACITOR	<i>Pump Single-phase</i>	<i>Capacitance (230 V)</i>	<i>(115 V or 127 V)</i>		
		JCRm 2C	20 µF - 450 VL	60 µF - 300 VL		
		JCRm 2B	25 µF - 450 VL	60 µF - 300 VL		
		JCRm 2A	25 µF - 450 VL	60 µF - 300 VL		
9	ELECTRIC MOTOR	<p>JCRm: single-phase 230 V - 60 Hz with thermal overload protector incorporated into the winding. JCR: three-phase 230/380 V - 60 Hz or 230/460 V - 60 Hz.</p> <p>⇒ The three-phase pumps are fitted with high performance motors in class IE2 (IEC 60034-30)</p> <ul style="list-style-type: none"> - Insulation: class F - Protection: IP X4 				

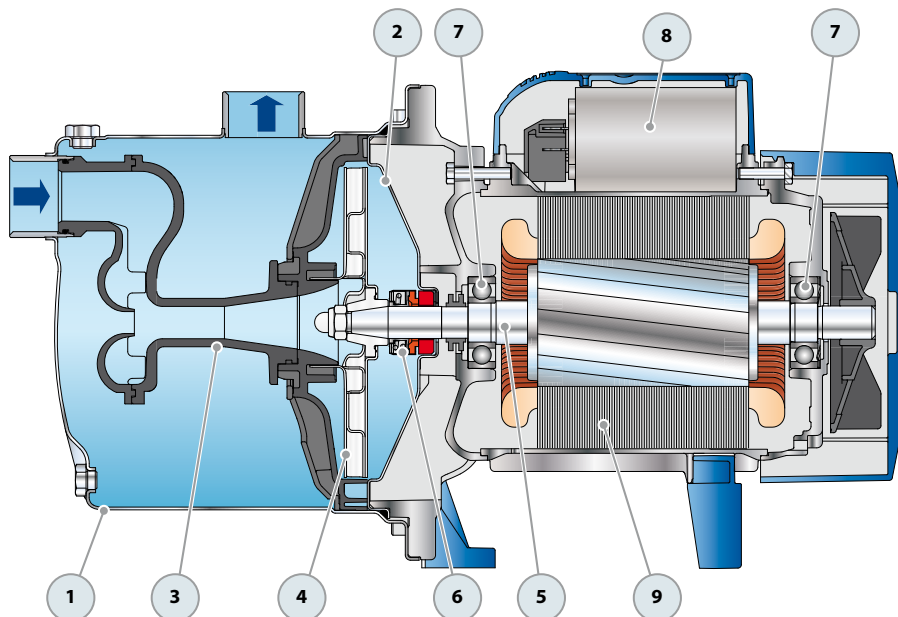

DIMENSIONS AND WEIGHT

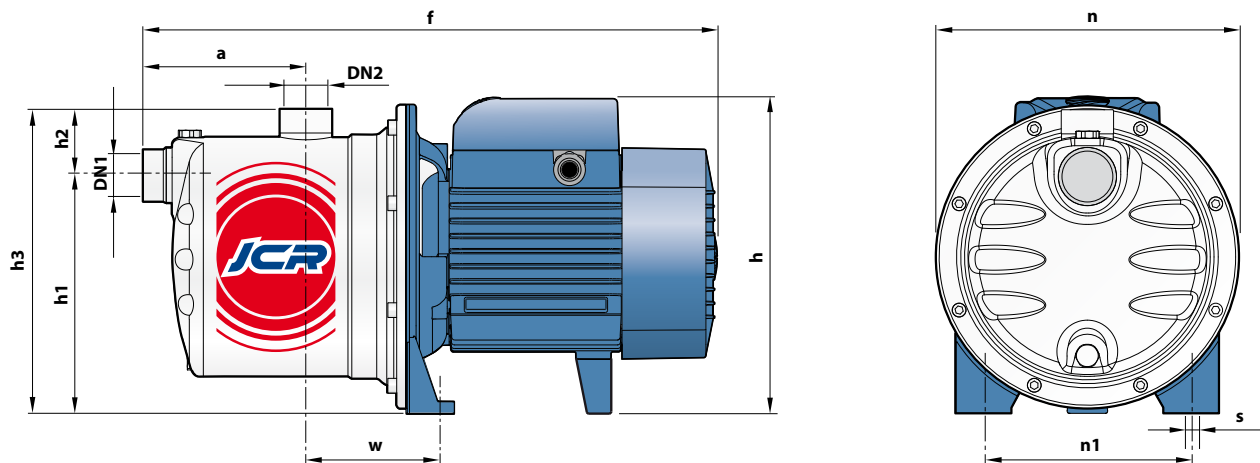

MODEL		PORTS (in)		DIMENSIONS mm										Lbs	
Single-phase	Three-phase	DN1	DN2	a	f	h	h1	h2	h3	n	n1	w	s	1~	3~
JCRm 2C	JCR 2C	1"	1"	111	393	217 *	162	46	208	208	142	91	10	22.48	22.48
JCRm 2B	JCR 2B													24.69	24.69
JCRm 2A	JCR 2A													25.35	25.35

(*) h=236 mm for single phase versions at 115V or 127 V

ABSORPTION

MODEL	VOLTAGE		
	230 V	115 V	127 V
Single-phase	230 V	115 V	127 V
JCRm 2C	5.0 A	10.0 A	9.0 A
JCRm 2B	6.7 A	13.4 A	12.2 A
JCRm 2A	6.9 A	13.8 A	12.9 A

MODEL	VOLTAGE			
	230 V	380 V	230 V	460 V
Three-phase	230 V	380 V	230 V	460 V
JCR 2C	3.8 A	2.2 A	3.6 A	2.0 A
JCR 2B	5.3 A	3.0 A	5.0 A	2.8 A
JCR 2A	5.8 A	3.3 A	5.5 A	3.1 A

PALLETIZATION

MODEL		GROUPAGE	CONTAINER
Single-phase	Three-phase	n. pumps	n. pumps
JCRm 2C	JCR 2C	60	80
JCRm 2B	JCR 2B	60	80
JCRm 2A	JCR 2A	60	80