

PLASTIC PAIL LID CLOSING PRESS-FLOOR MODEL - PLC-P-FM

APPROX WEIGHT: 250.87 lbs.
 DOES NOT INCLUDE WEIGHT OF POWER OR PACKAGING!!!

*** ANY ADDITIONS, DELETIONS, OR OMISSIONS MUST BE CORRECTED ON THIS DRAWING AS THIS DRAWING WILL BE CONSIDERED ALL INCLUSIVE ***
 ALL GRAPHICS PROVIDED ARE FOR REFERENCE ONLY. IF CERTAIN DIMENSIONS ARE CRITICAL PLEASE VERIFY THOSE DIMENSIONS WITH YOUR SALESPERSON

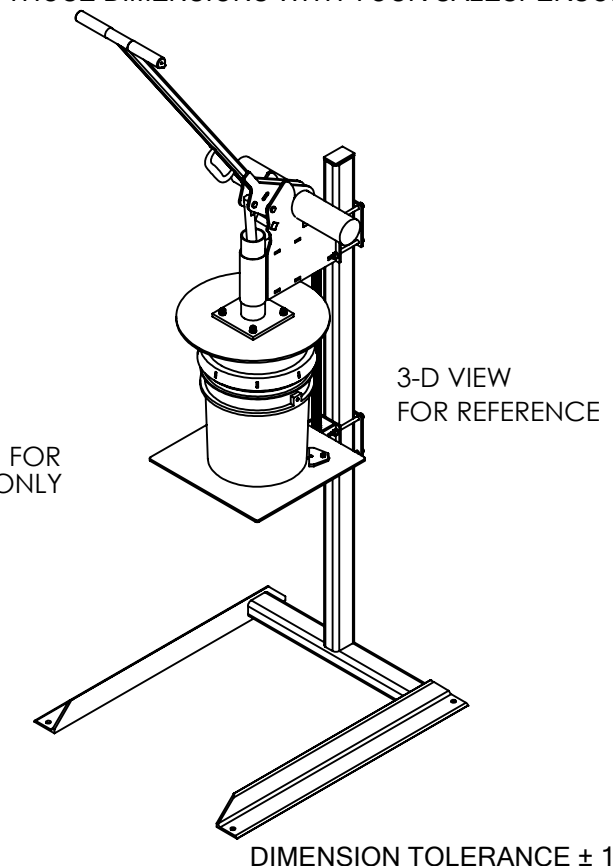
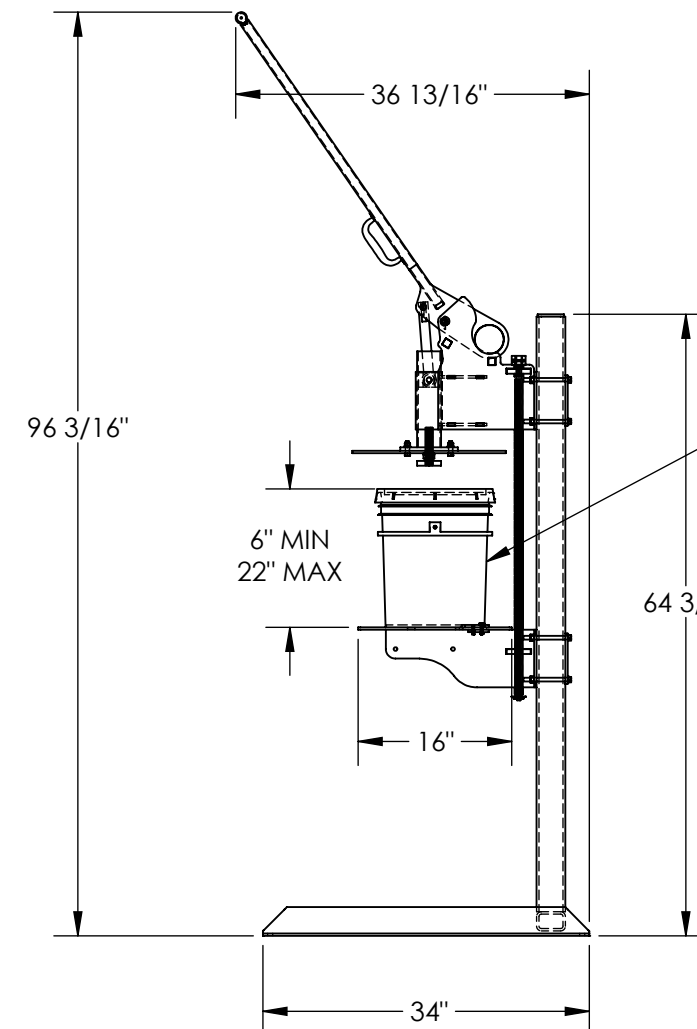
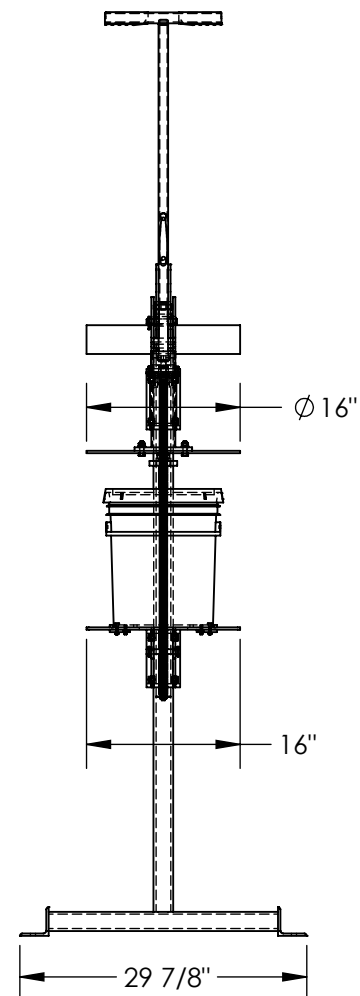

STANDARD FEATURES

- MODEL NUMBER IS PLC-P-FM
- PLATFORM LENGTH IS 16"
- PLATFORM WIDTH IS 16"
- OVERALL LENGTH IS 36 13/16"
- OVERALL WIDTH IS 29 7/8"
- OVERALL HEIGHT IS 96 3/16"
- COMPRESSION PLATE IS 16"
- WORKS WITH PAILS UP TO 7 GALLONS
- PAIL HEIGHT RANGE IS 6" THRU 22"
- MAX CAPACITY IS 250 LBS.
- DURABLE BAKED IN POWDER COATED BLUE FINISH FRAME AND YELLOW FINISH HANDLE

SPECIAL FEATURES

NONE

APPROVAL

I, THE UNDERSIGNED, AGREE THAT THE PRODUCT AS REPRESENTED SATISFIES DESIGN AND DIMENSION REQUIREMENTS. I ALSO ACKNOWLEDGE MY DUTY TO CONFIRM PRODUCT AND INSTALLATION COMPLIANCE WITH ALL APPLICABLE FEDERAL, STATE AND LOCAL REGULATIONS AND STANDARDS.
UNITS REQUIRING APPROVAL DRAWINGS OR MODIFIED ARE NON-RETURNABLE
 As drawn As marked

Signed: _____ Date: _____

Printed Name: _____

LEAD TIME WILL START UPON RECEIPT OF SIGNED APPROVAL DRAWING

DISTRIBUTOR'S NAME:		P.O.#
VESTIL MANUFACTURING		X
DRAWN BY: CA		W.O.#
DATE: 01/23/13		X
REFERENCE: X	SCALE: 1:20	SALES: X
QUOTED LEAD TIME: X	QUOTE #	FILE NAME:
	X	40-007-069