

ULTRA-TOW

Heavy-Duty Trailer Dolly with Brake

1200-Lb. Capacity

Owner's Manual



⚠ WARNING: Read carefully and understand all ASSEMBLY AND OPERATION INSTRUCTIONS before operating. Failure to follow the safety rules and other basic safety precautions may result in serious personal injury.

Item #58016

READ & SAVE THESE INSTRUCTIONS

Thank you very much for choosing an Ultra-Tow[®] product!

For future reference, please complete the owner's record below:

Serial Number/Lot Date Code: _____

Purchase Date: _____

Save the receipt, warranty, and this manual. It is important that you read the entire manual to become familiar with this product before you begin using it.

This dolly is designed for certain applications only. Northern Tool and Equipment is not responsible for issues arising from modification or improper use of this product such as an application for which it was not designed. We strongly recommend that this product not be modified and/or used for any application other than that for which it was designed.

For technical questions, please call **1-800-222-5381**.

Table of Contents

Intended Use.....4

Technical Specifications4

Important Safety Information4

Specific Operation Warnings5

Assembly Instructions.....6

Before Each Use.....6

Operating Instructions.....7

Maintenance8

Parts Diagram8

Parts List9

Replacement Parts9

Limited Warranty.....10

Intended Use

Ultra-Tow's 1200 Lb. Capacity Heavy-Duty Trailer Dolly with Brake has a three-wheel design which makes maneuvering trailers easier than two-wheel models. The versatile design features flat-free tires and an adjustable height for many different trailer tongue heights.

Technical Specifications

Property	Specification
Capacity	1200 lb.
Tires	2-16" Flat Free Tires with 2 10" Flat Free Swivel Wheel
Construction	Steel
Hitch Ball Size	2"
Adjustable Height	21-1/4" to 34-5/8"
Dimensions	44-1/2" x 42-1/8" x 37-3/8"

Important Safety Information

⚠WARNING

- Read and understand all instructions. Failure to follow all instructions may result in serious injury or property damage.
- The warnings, cautions, and instructions in this manual cannot cover all possible conditions or situations that could occur. Exercise common sense and caution when using this tool. Always be aware of the environment and ensure that the tool is used in a safe and responsible manner.
- Do not allow persons to operate or assemble the product until they have read this manual and have developed a thorough understanding of how it works.
- Do not modify this product in any way. Unauthorized modification may impair the function and/or safety and could affect the life of the product. There are specific applications for which the product was designed.
- Use the right tool for the job. DO NOT attempt to force small equipment to do the work of larger industrial equipment. There are certain applications for which this equipment was designed. This product will be safer and do a better job at the capacity for which it was intended. DO NOT use this equipment for a purpose for which it was not intended.
- Industrial or commercial applications must follow OSHA requirements.

⚠WARNING

WORK AREA SAFETY

- Inspect the work area before each use. Keep work area clean, dry, free of clutter, and well-lit. Cluttered, wet, or dark work areas can result in injury. Using the product in confined work areas may put you dangerously close to cutting tools and rotating parts.
- Do not allow the product to come into contact with an electrical source. The tool is not insulated and contact will cause electrical shock.
- Keep children and bystanders away from the work area while operating the tool. Do not allow children to handle the product.

- Be aware of all power lines, electrical circuits, water pipes, and other mechanical hazards in your work area. Some of these hazards may be hidden from your view and may cause personal injury and/or property damage if contacted.

⚠WARNING

PERSONAL SAFETY

- Stay alert, watch what you are doing, and use common sense when operating the tool. Do not use the tool while you are tired or under the influence of drugs, alcohol, or medication. A moment of inattention while operating the tool may result in serious personal injury.
- Dress properly. Do not wear loose clothing, dangling objects, or jewelry. Keep your hair, clothing and gloves away from moving parts. Loose clothes, jewelry, or long hair can be caught in moving parts. Air vents on the tool often cover moving parts and should be avoided.
- Wear the proper personal protective equipment when necessary. Use ANSI Z87.1 compliant safety goggles (not safety glasses) with side shields, or when needed, a face shield. Use a dust mask in dusty work conditions. Also use non-skid safety shoes, hardhat, gloves, dust collection systems, and hearing protection when appropriate. This applies to all persons in the work area.
- Do not overreach. Keep proper footing and balance at all times.
- Secure the work with clamps or a vise instead of your hand when practical. This safety precaution allows for proper tool operation using both hands.

⚠CAUTION

DOLLY USE AND CARE

- Do not force the dolly. Products are safer and do a better job when used in the manner for which they are designed. Plan your work, and use the correct product for the job.
- Check for damaged parts before each use. Carefully check that the product will operate properly and perform its intended function. Replace damaged or worn parts immediately. Never operate the product with a damaged part.
- Store the dolly when it is not in use. Store it in a dry, secure place out of the reach of children. Inspect the tool for good working condition prior to storage and before re-use.
- Use only accessories that are recommended by the manufacturer for use with your product. Accessories that may be suitable for one product may create a risk of injury when used with another tool. Never use an accessory that has a lower operating speed or operating pressure than the tool itself.

Specific Operation Warnings

⚠WARNING

- To prevent serious injury or property damage, read and understand owner's manual before operating.
- DO NOT exceed the rated load capacity.
- Distribute the load evenly. Uneven loads may cause the dolly to tip, resulting in personal injury to the operator or others.
- Always be aware of dynamic loading. An excess load may be created for a brief instant by a

sudden tug or weight gain, which can result in damage to the product or personal injury.

- Always keep arms, feet and legs out from under the trailer tongue while hitching, unhitching or moving the trailer.
- Wear ANSI Z87.1 safety goggles during use.
- Always make sure the loaded trailer is chocked properly before moving the dolly into place.
- Maintain proper tire pressure at all times. DO NOT over inflate tire. Over inflation may cause the tire to burst or the rim to separate, causing serious personal injury.
- Be sure the trailer tongue is securely connected to the trailer dolly coupler ball before unlocking and moving the trailer. Use best judgment to prevent sudden uncontrolled movement of the trailer once it is connected.
- NEVER LEAVE a dolly under load unattended.
- Always check for damaged or worn parts before using the dolly. Replace or repair damaged or worn parts before using the dolly.
- Use the dolly on flat and level surfaces capable of supporting the dolly and its maximum load. Pulling or pushing a load on a slanted or uneven surface can result in loss of control.
- Do not modify the dolly in any way. Unauthorized modification may impair the function and/or safety and could affect the life of the equipment. There are specific applications for which the dolly was designed.
- Store an idle dolly. When the dolly is not in use, store it in a secure place out of the reach of children. Inspect it for good working condition prior to storage and before re-use.
- Not for use by or around children.

Assembly Instructions

- Attach Wheel Mount Plate (#11) to the Axle Assembly (#1) using a Bolt (#14) and Lock Nut (#10).
- Attach two 10" Brake Casters (#12) to the Wheel Mount Plate (#11) with a Lock Nut (#10) and Bolt (#13).
- Connect Handle Tube (#8) to the Axle Assembly (#1) using a Bolt (#9) and Lock Nut (#10).
- Connect Handle Tube (#8) and Wheel Mount Plate (#11) with Bracket (#15).
- Insert 2" Ball Mount Bracket (#6) into Axle Assembly (#1) and secure with a Safety Pin (#4) and Pin Shaft (#5).
- Install the 2" Trailer Hitch Ball (#7) onto the 2" Ball Mount Bracket (#6).
- Install two 16" Wheels (#2) to Axle Assembly (#1) using Plate Washer (#3) and Safety Pin (#4).
- Connect two Wire Brakes (#17) through Axle Assembly (#1) and Handle Tube (#8) with the top of Handle (#16),
- Test and adjust the Wire Brake (#17) until it's in a comfortable place in the Axle Assembly (#1).
- Check and tighten all hardware as needed.

Before Each Use

WARNING

- Always make sure the loaded trailer is chocked properly before moving the dolly into place.

- Always check for damaged or worn parts before using the dolly. Replace or repair damaged or worn parts before using the dolly.

Operating Instructions

⚠WARNING

- DO NOT exceed the rated load capacity.
- Distribute the load evenly. Uneven loads may cause the dolly to tip, resulting in personal injury to the operator or others.
- Always be aware of dynamic loading. An excess load may be created for a brief instant by a sudden tug or weight gain, which can result in damage to the product or personal injury.
- Always keep arms, feet and legs out from under the trailer tongue while hitching, unhitching or moving the trailer.
- Wear ANSI Z87.1 safety goggles during use.
- Always make sure the loaded trailer is chocked properly before moving the dolly into place.
- Be sure the trailer tongue is securely connected to the trailer dolly coupler ball before unlocking and moving the trailer. Use best judgment to prevent sudden uncontrolled movement of the trailer once it is connected.
- NEVER LEAVE a dolly under load unattended.
- Always check for damaged or worn parts before using the dolly. Replace or repair damaged or worn parts before using the dolly.
- Use the dolly on flat and level surfaces capable of supporting the dolly and its maximum load. Pulling or pushing a load on a slanted or uneven surface can result in loss of control.
- Do not modify the dolly in any way. Unauthorized modification may impair the function and/or safety and could affect the life of the equipment. There are specific applications for which the dolly was designed.
- Store an idle dolly. When the dolly is not in use, store it in a secure place out of the reach of children. Inspect it for good working condition prior to storage and before re-use.
- Not for use by or around children.

- Position the assembled dolly under the trailer tongue/coupler.
- Secure the coupler to the trailer ball on the trailer dolly.
- Once secured, move trailer to the desired location.

Maintenance

Maintain the product by adopting a program of conscientious repair and maintenance in accordance with the following recommended procedures. It is recommended that the general condition of any tool be examined before it is used. Keep your tool in good repair. Keep handles dry, clean, and free from oil and grease. The following chart is based on a normal operation schedule.

Maintenance Interval	Maintenance Point
Daily before operating	Maintain your dolly. It is recommended that the general condition of any dolly be examined before it is used. Keep your dolly in good repair by adopting a program of conscientious repair and maintenance. Have necessary repairs made by qualified service personnel.

Parts Diagram

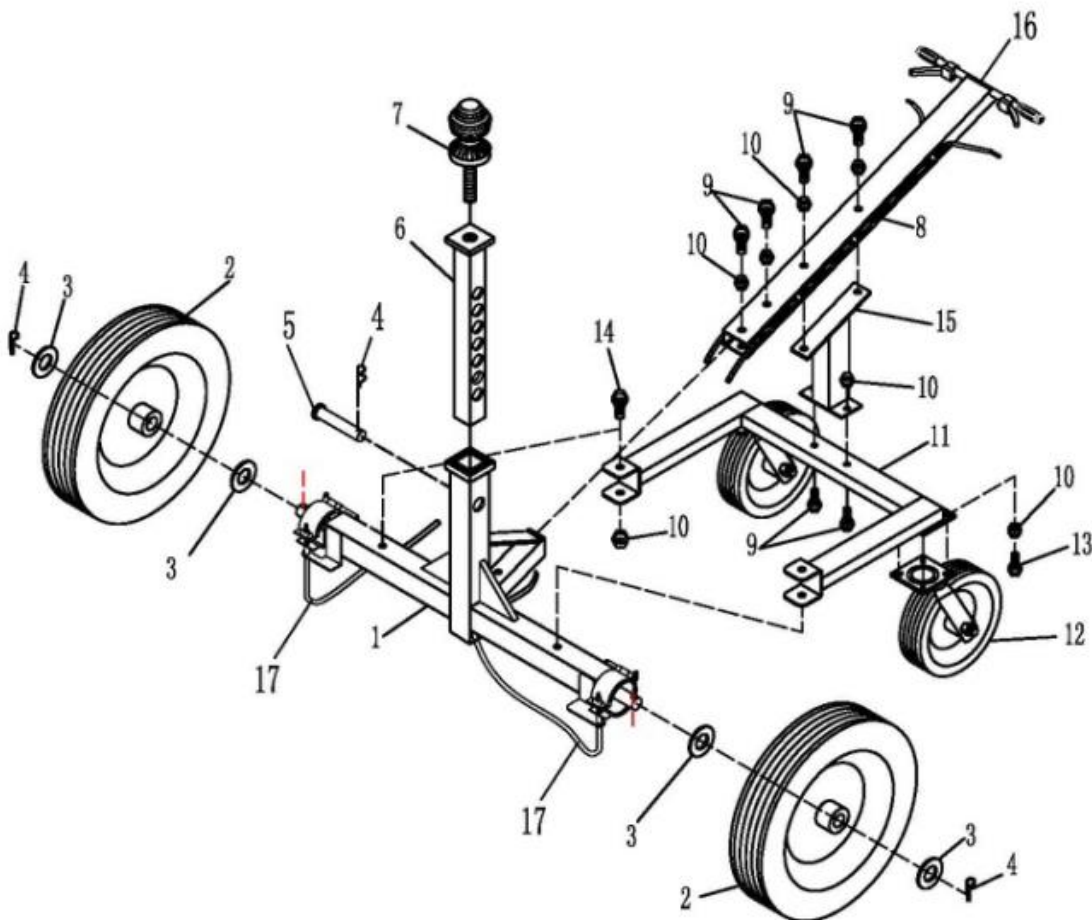

Parts List

Reference	Part Description	Quantity
1	Alex Assembly	1
2	16" Wheel	2
3	Plate Washer	4
4	Safety Pin	5
5	Pin Shaft	1
6	2" Ball Mount Bracket	1
7	2" Trailer Hitch Ball	1
8	Handle Tube	1
9	Bolt M10x50	6
10	Lock Nut M10	16
11	Wheel Mounting Plate	1
12	10" Caster	2
13	Bolt M10x25	8
14	Bolt M10x75	2
15	Bracket	1
16	Handle	1
17	Wire Brake	2

Replacement Parts

- For replacement parts and technical questions, please call Customer Service at **1-800-222-5381**.
- Not all product components are available for replacement. The illustrations provided are a convenient reference to the location and position of parts in the assembly sequence.
- When ordering parts, the following information will be required: item description, item model number, item serial number/item lot date code, and the replacement part reference number.
- The distributor reserves the rights to make design changes and improvements to product lines and manuals without notice.

Limited Warranty

Northern Tool and Equipment Company, Inc. ("We" or "Us") warrants to the original purchaser only ("You" or "Your") that the Ultra-Tow product purchased will be free from material defects in both materials and workmanship, normal wear and tear excepted, for a period of **one year** from date of purchase. The foregoing warranty is valid only if the installation and use of the product is strictly in accordance with product instructions. There are no other warranties, express or implied, including the warranty of merchantability or fitness for a particular purpose. If the product does not comply with this limited warranty, Your sole and exclusive remedy is that We will, at our sole option and within a commercially reasonable time, either replace the product or product component without charge to You or refund the purchase price (less shipping). This limited warranty is not transferable.

Limitations on the Warranty

This limited warranty does not cover: (a) normal wear and tear; (b) damage through abuse, neglect, misuse, or as a result of any accident or in any other manner; (c) damage from misapplication, overloading, or improper installation; (d) improper maintenance and repair; and (e) product alteration in any manner by anyone other than Us, with the sole exception of alterations made pursuant to product instructions and in a workmanlike manner.

Obligations of Purchaser

You must retain Your product purchase receipt to verify date of purchase and that You are the original purchaser. To make a warranty claim, contact Us at 1-800-222-5381, identify the product by make and model number, and follow the claim instructions that will be provided. The product and the purchase receipt must be provided to Us in order to process Your warranty claim. Any returned product that is replaced or refunded by Us becomes our property. You will be responsible for return shipping costs or costs related to Your return visit to a retail store.

Remedy Limits

Product replacement or a refund of the purchase price is Your sole remedy under this limited warranty or any other warranty related to the product. We shall not be liable for: service or labor charges or damage to Your property incurred in removing or replacing the product; any damages, including, without limitation, damages to tangible personal property or personal injury, related to Your improper use, installation, or maintenance of the product or product component; or any indirect, incidental or consequential damages of any kind for any reason.

Assumption of Risk

You acknowledge and agree that any use of the product for any purpose other than the specified use(s) stated in the product instructions is at Your own risk.

Governing Law

This limited warranty gives You specific legal rights, and You also may have other rights which vary from state to state. Some states do not allow limitations or exclusions on implied warranties or incidental or consequential damages, so the above limitations may not apply to You. This limited warranty is governed by the laws of the State of Minnesota, without regard to rules pertaining to conflicts of law. The state courts located in Dakota County, Minnesota shall have exclusive jurisdiction for any disputes relating to this warranty.

ULTRA-TOW

Distributed by:

Northern Tool & Equipment Company, Inc.

Burnsville, Minnesota 55306

www.northerntool.com

Made in China