

KLUTCH

17" Floor Drill Press

Owner's Manual



C US
227541

⚠ WARNING: Read carefully and understand all ASSEMBLY AND OPERATION INSTRUCTIONS before operating. Failure to follow the safety rules and other basic safety precautions may result in serious personal injury.

Item #5793513

READ & SAVE THESE INSTRUCTIONS

Thank you very much for choosing a Klutch product!

For future reference, please complete the owner's record below:

Serial Number/Lot Date Code: _____

Purchase Date: _____

Save the receipt, warranty, and this manual. It is important that you read the entire manual to become familiar with this product before you begin using it.

This 17" Floor Drill Press is designed for certain applications only. Northern Tool & Equipment is not responsible for issues arising from modification or improper use of this product such as an application for which it was not designed. We strongly recommend that this product not be modified and/or used for any application other than that for which it was designed.

For technical questions, please call **1-800-222-5381**.

Table of Contents

Intended Use.....	4
Packaging Contents.....	4
Technical Specifications	4
Important Safety Information	5
Specific Operation Warnings	8
Grounding	9
Extension Cords.....	10
Main Parts of Product.....	11
Assembly Instructions.....	12
Operating Instructions.....	15
Maintenance	19
Troubleshooting.....	21
Parts Diagram.....	22
Parts List.....	23
Replacement Parts	25
Limited Warranty.....	26

Intended Use

17" Floor Drill Press offers 16 speeds, enabling you to choose the best speed for the job. It comes equipped with a quick-release, crank-operated worktable, worklight, X-pattern mounting grooves, depth stop, and adjustable tension spindle return spring--ideal for repetitive drilling of the same depth. .

Packaging Contents

- | | | |
|---|--|--|
| <ul style="list-style-type: none"> • Drill Head • Base • Rack • Chuck • Manual | <ul style="list-style-type: none"> • Column • Work Table • Oil Bottle • Collar | <ul style="list-style-type: none"> • Column Support • Table Support Assembly • Handle • Thickness Break Iron |
| <ul style="list-style-type: none"> • Hardware Bag
(Please refer to the list on the right for details) | <ul style="list-style-type: none"> Table Crank Bolt Spring Washer Chuck Key | <ul style="list-style-type: none"> Hex Key Flat Washer Locking Screw |

Technical Specifications

Property	Specification
Motor	120VAC, 60Hz, 7.5A
Spindle Speeds	220, 290, 360, 430, 500, 570, 640, 730, 810, 900, 1460, 1730, 1820, 2380, 2650, 3600
Spindle Stroke	4"
Spindle Taper	MT3
Chuck Capacity	1/8" to 5/8"
Swing	17"
Table Diameter	12-7/8"
Table Rotation	360°
Table Tilt	45° left and 45° right
Column Diameter	3-3/16"
Certification	CSA certification

Important Safety Information

⚠WARNING

- Read and understand all instructions. Failure to follow all instructions may result in serious injury or property damage.
- The warnings, cautions, and instructions in this manual cannot cover all possible conditions or situations that could occur. Exercise common sense and caution when using this tool. Always be aware of the environment and ensure that the tool is used in a safe and responsible manner.
- Do not allow persons to operate or assemble the product until they have read this manual and have developed a thorough understanding of how it works.
- Do not modify this product in any way. Unauthorized modification may impair the function and/or safety and could affect the life of the product. There are specific applications for which the product was designed.
- Use the right tool for the job. DO NOT attempt to force small equipment to do the work of larger industrial equipment. There are certain applications for which this equipment was designed. It will be a safer experience and do the job better at the capacity for which it was intended. DO NOT use this equipment for a purpose for which it was not intended.
- Industrial or commercial applications must follow OSHA requirements.

⚠WARNING

- This product may contain chemicals known to the state of California to cause cancer, birth defects, or other reproductive harm.
- Some dust created by power sanding, sawing, grinding, drilling, and other construction activities contains chemicals known to the state of California to cause cancer, birth defects, or other reproductive harm. Some examples of these chemicals are:
 - - lead from lead-based paints,
 - - crystalline silica from bricks and cement and other masonry products, and
 - - arsenic and chromium from chemically-treated lumber.
- Your risk from these exposures varies, depending on how often you do this type of work. To reduce your exposure to these chemicals: work in a well-ventilated area, and work with approved safety equipment, such as dust masks that are specially designed to filter out microscopic particles.
- Handling power cords on corded products may expose you to lead, a chemical known to the state of California to cause cancer and birth defects or other reproductive harm. Wash your hands after handling.

⚠WARNING

WORK AREA SAFETY

- Inspect the work area before each use. Keep work area clean, dry, free of clutter, and well-lit. Cluttered, wet, or dark work areas can result in injury. Using the product in confined work areas may put you dangerously close to cutting tools and rotating parts.
- Do not use the product where there is a risk of causing a fire or an explosion; e.g., in the presence of flammable liquids, gases, or dust. The product can create sparks, which may ignite the flammable liquids, gases, or dust.
- Do not allow the product to come into contact with an electrical source. The tool is not insulated and contact will cause electrical shock.
- Keep children and bystanders away from the work area while operating the tool. Do not allow children to handle the product.
- Be aware of all power lines, electrical circuits, water pipes, and other mechanical hazards in your work area. Some of these hazards may be hidden from your view and may cause personal injury and/or property damage if contacted.

⚠WARNING

PERSONAL SAFETY

- Stay alert, watch what you are doing, and use common sense when operating the tool. Do not use the tool while you are tired or under the influence of drugs, alcohol, or medication. A moment of inattention while operating the tool may result in serious personal injury.
- Dress properly. Do not wear loose clothing, dangling objects, or jewelry. Keep your hair, clothing and gloves away from moving parts. Loose clothes, jewelry, or long hair can be caught in moving parts. Air vents on the tool often cover moving parts and should be avoided.
- Wear the proper personal protective equipment when necessary. Use ANSI Z87.1 compliant safety goggles (not safety glasses) with side shields, or when needed, a face shield. Use a dust mask in dusty work conditions. Also use non-skid safety shoes, hardhat, gloves, dust collection systems, and hearing protection when appropriate. This applies to all persons in the work area.
- Do not overreach. Keep proper footing and balance at all times.

⚠ CAUTION

PRODUCT USE AND CARE

- Do not force the product. Products are safer and do a better job when used in the manner for which they are designed. Plan your work, and use the correct product for the job.
- Check for damaged parts before each use. Carefully check that the product will operate properly and perform its intended function. Replace damaged or worn parts immediately. Never operate the product with a damaged part.
- Store the product when it is not in use. Store it in a dry, secure place out of the reach of children. Inspect the tool for good working condition prior to storage and before re-use.
- Use only accessories that are recommended by the manufacturer for use with your product. Accessories that may be suitable for one product may create a risk of injury when used with another tool. Never use an accessory that has a lower operating speed or operating pressure than the tool itself.
- Keep guards in place and in working order. Never operate the product without the guards in place.

Specific Operation Warnings

⚠WARNING

- Wear eye protection.
- Do not wear gloves, necktie, or loose clothing.
- Clamp workpiece or brace against column to prevent rotation.
- Use recommended speed for drill accessory and workpiece material.
- The included chuck key is specially designed to be self-ejecting, reducing the risk of ejecting at high speed. Only use the included chuck key or an identical replacement key.
- **DO NOT OPERATE WITH ANY GUARD DISABLED, DAMAGED, OR REMOVED.** Moving guards must move freely and close instantly.
- The use of accessories or attachments not recommended by the manufacturer may result in a risk of injury to persons.
- When servicing use only identical replacement parts.
- Only use safety equipment that has been approved by an appropriate standards agency. Unapproved safety equipment may not provide adequate protection. Eye protection must be ANSI-approved and breathing protection must be NIOSH-approved for the specific hazards in the work area.
- Stay alert, watch what you are doing and use common sense when operating a power tool. Do not use a power tool while you are tired or under the influence of drugs, alcohol or medication. A moment of inattention while operating power tools may result in serious personal injury.
- Industrial applications must follow OSHA guidelines.
- Maintain labels and nameplates on the tool. These carry important safety information. If unreadable or missing, contact Northern Tool Equipment
- Avoid unintentional starting. Prepare to begin work before turning on the tool.
- Arsenic and chromium from chemically treated lumber
- The warnings, precautions, and instructions discussed in this instruction manual cannot cover all possible conditions and situations that may occur. It must be understood by the operator that common sense and caution are factors which cannot be built into this product, but must be supplied by the operator.
- Do not smoke during use. Nicotine reduces the blood supply to the hands and fingers, increasing the risk of vibration-related injury.
- Grip tool as lightly as possible (while still keeping safe control of it). Let the tool do the work.

Grounding

⚠WARNING

- This machine must be grounded while in use to protect the operator from electrical shock. This unit is equipped with an electrical cord that has an equipment grounding conductor and a grounding plug. The plug **MUST** be plugged into a matching receptacle that is properly installed and grounded in accordance with ALL local codes and ordinances.
- **DO NOT MODIFY THE PROVIDED PLUG.** If it will not fit the receptacle, have the proper receptacle installed by a qualified electrician.

CHECK with a qualified electrician or service person if you do not completely understand the grounding instructions, or if you are not sure the tool is properly grounded.

Grounded Tools: Tools with 3-Prong Plugs

Tools marked **Grounding Required** have a 3-wire cord and 3-prong grounding plug. The plug must be connected to a properly grounded outlet. If the tool should electrically malfunction or break down, grounding provides a low resistance path to carry electricity away from the user, reducing the risk of electric shock. (See Figure A.)

The grounding prong in the plug is connected through the green wire inside the cord to the grounding system in the tool. The green wire in the cord must be the only wire connected to the tool's grounding system and must never be attached to an electrically live terminal.

Your tool must be plugged into an appropriate outlet, properly installed and grounded in accordance with all codes and ordinances. The plug and outlet should look like those in the following illustration.

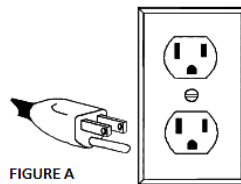

FIGURE A

Double Insulated Tools: Tools with Two-Prong Plugs

Tools marked **Double Insulated** do not require grounding. They have a special double insulation system which satisfies OSHA requirements and complies with the applicable standards of Underwriters Laboratories, Inc., the Canadian Standard Association, and the National Electrical Code. (See Figure B.)

Double insulated tools may be used in either of the 120 volt outlets shown in the following illustration.

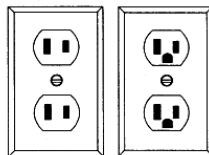

FIGURE B

Extension Cords

⚠WARNING

- **USE A PROPER EXTENSION CORD.** Make sure your extension cord is in good condition. When using an extension cord, be sure to use one heavy enough to carry the current your product will draw. An undersized cord will cause a drop in line voltage, resulting in loss of power and cause overheating.
- Be sure your extension cord is properly wired and in good condition. Always replace a damaged extension cord or have it repaired by a qualified person before using it. Protect your extension cords from sharp objects, excessive heat and damp or wet areas.
- Grounded tools require a 3-wire extension cord. Double Insulated tools can use either a 2- or 3-wire extension cord.
- As the distance from the supply outlet increases, you must use a heavier gauge extension cord. Using extension cords with inadequately sized wire causes a serious drop in voltage, resulting in loss of power and possible tool damage.
- The smaller the wire's gauge number, the greater the capacity of the cord. For example, a 14-gauge cord can carry a higher current than a 16-gauge cord. Minimum extension cord wire size is shown in the following table:

Minimum Wire Size Of Extension Cords				
Nameplate AMPS	Cord Length			
	25'	50'	100'	150'
0-6	18 AWG	16 AWG	16 AWG	14 AWG
6-10	18 AWG	16 AWG	14 AWG	12 AWG
10-12	16 AWG	16 AWG	14 AWG	12 AWG
12-16	14 AWG	12 AWG	NOT RECOMMENDED	

- When using more than one extension cord to make up the total length, make sure each cord contains at least the minimum wire size required.
- If you are using one extension cord for more than one tool, add the nameplate amperes and use the sum to determine the required minimum cord size.
- If you are using an extension cord outdoors, make sure it is marked with the suffix **W-A** (**W** in Canada) to indicate it is acceptable for outdoor use.
- Make sure your extension cord is properly wired and in good electrical condition. Always replace a damaged extension cord or have it repaired by a qualified electrician before using it.
- Protect your extension cords from sharp objects, excessive heat, and damp or wet areas.

Main Parts of Product

Subassembly
Pulley Cover
Belt Tension lock Knob
Belt Tension lever
Feed Handle
Table Crank
Base
Column
Table
Depth Scale locking Screw
Pointer
Depth Scale

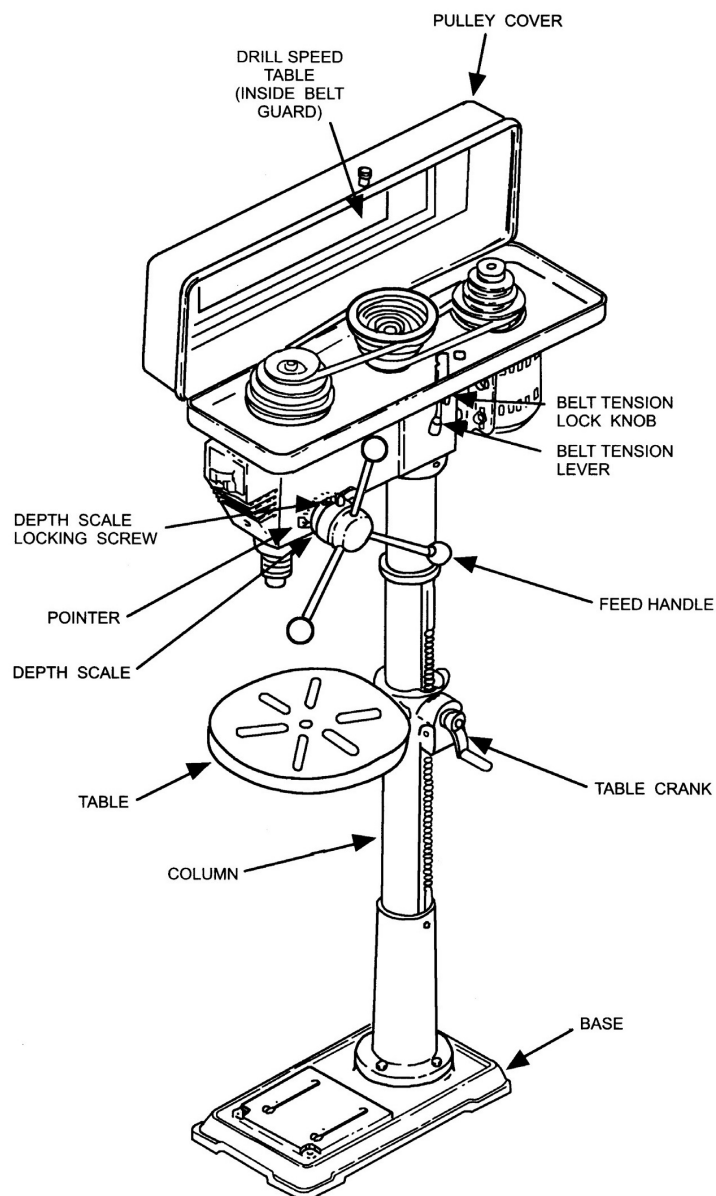

Assembly Instructions

⚠WARNING

- Turn the power Switch of the tool off and unplug the tool from its electrical outlet before performing any procedure.
- Before assembling and using the Drill Press, secure the Base to a supporting structure.
- Verify that the intended installation surface has no hidden utility lines before drilling or driving screws.
- Bolt the Base to a flat, level, solid floor location capable of supporting the weight of the Drill Press and any workpieces.

COLUMN ASSEMBLY TO BASE

1. Attach the Column Support (2) to the Base (1) using the four M10x35 Bolts (5), four Spring Washers (4) and four Flat Washers (3).
2. Tighten the Bolts firmly
3. Insert the Column (7) into the Support and firmly secure this assembly in place with the Set Screws (6).

Note: It may be necessary to back the Set Screws out beforehand, as they may protrude into the Support tube, preventing the Column from sliding fully into the Column Support.

TABLE TO COLUMN

1. Lubricate the Worm Gear (45) teeth with light grease and insert the Gear shaft-first into the Table Support (46). Extend the shaft as far as possible through the opening in the side of the Support. See Figure A.
2. Insert the Table Crank (41) onto the protruding Worm Gear shaft. Align the Table Crank's Set Screw (40) with the flat portion of the Worm Gear shaft. Make sure the Worm Gear shaft is inserted as far as possible into the Crank, then tighten the Set Screw. See Figure A.
3. Use the Socket Head Cap Screw (44) to attach the Table Crank Handle (43) to the Table Crank. Use a hex key (not supplied) to securely tighten the Crank Handle.
4. Loosen the Set Screw (16) in the Collar (17) and remove the Collar and Rack (8) from the Column. The Rack is stowed in this position only for transit purposes.
5. With the long smooth end of the Rack upper most, slide the Rack down through the notch in the opening in the Table Support, as shown in Figure B. Engage the Rack into the Gear Mechanism located on the inside of the Table Support.

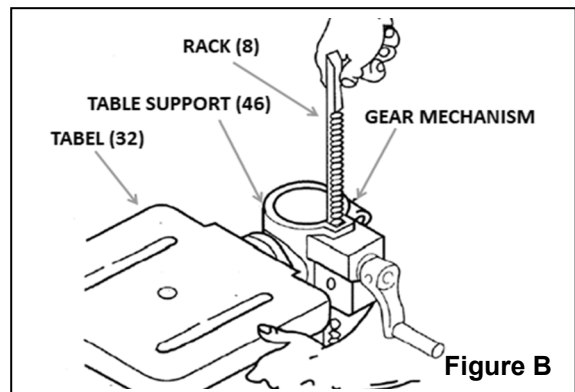
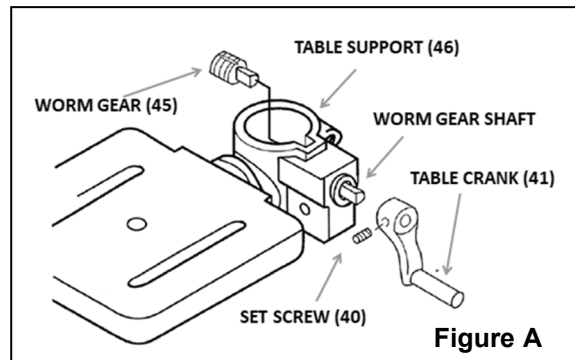

6. While holding the Rack and the Table Support as assembled, slide both down onto the Column. Slide the Rack down until the bottom of the Rack is positioned against the Column Support.
7. Replace the Collar onto the Column with its beveled side down, ensuring that the top end of the Rack is engaged in the groove formed between the Collar and the Column.
IMPORTANT: Make sure the Rack is not pinched and there is a working clearance between the Rack and Collar.
8. Tighten the Collar Set Screw.
Note: For the Rack to move easily when the Table is rotated around on the Column, the Collar must sit evenly on the Column and fit loosely over the top of the Rack. Only tighten the Collar Set Screw enough to keep the Collar in place on the Column. Overtightening the Set Screw may damage the Collar.
9. Check the Collar for proper adjustment. The Rack should move freely when the Table is rotated the full 360° around the Column.
10. Screw the Table Lock Handle (36) into the Table Support but do not tighten it all the way. Once this is done, turn the Crank, testing to ensure that the Table Support easily travels up and down the full length of the Rack without binding, and that the assembly and the Rack rotate freely all the way around the Column without binding.
IF THE TABLE SUPPORT IS TOO TIGHT:
 - Slightly loosen the Table Lock Handle and loosen the Collar Set Screw.
 - Adjust the Collar slightly to provide a greater working clearance between the Rack and the Collar
 - Tighten the Collar Set Screw, and test the Table Support's movement again.

HEAD ASSEMBLY TO COLUMN

1. Before installing the Head Assembly, it may be necessary to back the four Socket Head Cap Screws (6) out slightly to ensure they do not protrude internally, as this would prevent the Head Assembly from sliding fully into position. as shown in Figure C
2. With assistance, raise the Head assembly and locate it on top of the Column.
3. Align the Head with the Base, and firmly secure it with the Set Screws.
4. Screw the three Spindle Feed Handle Bars (9) firmly into the Spindle Feed Hub (10).

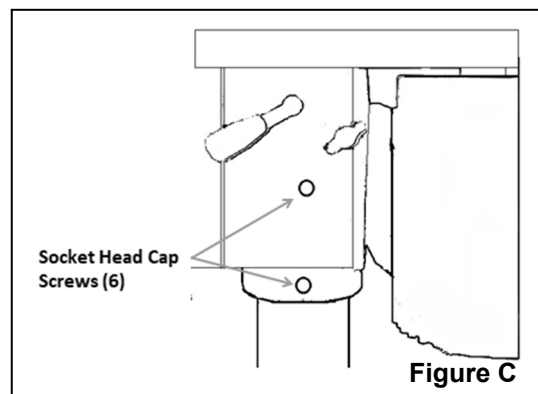

ATTACHING THE PULLEY COVER HANDLE

1. Slide the Pulley Cover Handle (118) into the hole in the front of the Pulley Cover.
2. Put the Cross-Shape Screw (28) through the Flat Washer (27) and twist it into the Handle from the inside of the Pulley Cover.

INSTALLING THE CUTTING OIL SYSTEM

1. Use four Socket Head Cap Screws (120) and four Rubber Pads (88) to attach the two Oil Bottle Clips (121) to the tapped holes in the left side of the Head.
2. Thread the Oil Pipe (76) into the bottom of one of the Oil Bottles (56), screw an Oil Bottle Cap (53) onto the Bottle and snap the Bottle into the Oil Bottle Clips.

INSTALLING THE BELTS

1. Undo the Belt Tension Locking Knobs (87) on both sides of the Head. Turn the Belt Tension Lever (97) clockwise to bring the Motor Pulley (109) towards the Spindle Pulley (69), allowing the Belts to be easily slipped over the Pulleys. as shown in Figure D
2. Lubricate the Idler Pivot Shaft (111) and Idler Pulley (112) with light grease, and install the Pivot Shaft in its mounting between the Motor Pulley and Spindle Pulley.

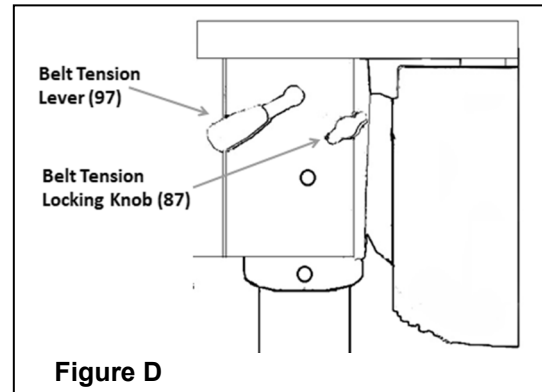

3. Consult the chart inside the Pulley Cover (Figure G on page 16), and install the Belts (70, 113) in the positions corresponding to the required spindle/drill speed.
4. Turn the Belt Tension Lever counterclockwise so that tension is applied to the belts. as shown in Figure E

IMPORTANT: Tension is correct when the belts deflect by approximately 1/2" at their centers of run when using reasonable thumb pressure.

5. Use the Belt Tension Locking Knobs to lock the Motor Pulley in this position.

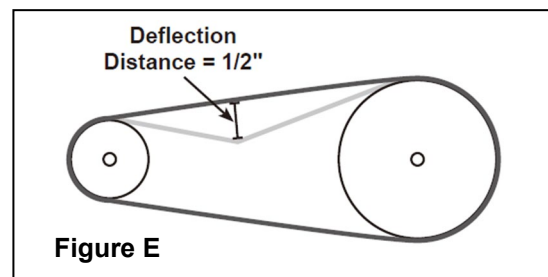

INSTALLING THE CHUCK

1. Loosen the Table Lock Handle (36) and slide the Table up the Column to within 6" of the Arbor (58). Tighten the Lock Handle.
2. Thoroughly clean the Arbor and the tapered hole in the Chuck (57) of all dirt, grease, oil, and protective coatings.
3. Slide the Chuck onto the Arbor.
4. Examine the Chuck from all sides to make sure that it is straight.
5. Open the jaws of the Chuck to their maximum, using the supplied Chuck Key.
6. Put a piece of scrap wood on the table to protect the Chuck nose.
7. Using the Spindle Feed Handles, lower the Spindle and press the Chuck nose hard against the scrap wood on the table until the Chuck is forced into a solid fit. The Chuck is pressure fitted.

Operating Instructions

⚠WARNING

- Turn the Power Switch of the tool off and unplug the tool from its electrical outlet before performing any procedure in this section.
- DO NOT OPERATE WITH ANY GUARD DISABLED, DAMAGED, OR REMOVED. Moving guards must move freely and close instantly.
- Turn off and unplug the Drill Press before changing drill speed.

TABLE ADJUSTMENT

The Table is capable of moving in four directions.

1. Raise or lower the Table by loosening the Table Support Locking Handle (A) and turning the Table Crank (C): clockwise to raise the Table and counterclockwise to lower the Table.
2. Swivel the Table around the column by loosening the Table Support Locking Handle. The table assembly, arm and rack (B), move as one around the column.
3. Tilt the table by loosening the Bolt (E), and tilting the Table to the required angle. A scale (F) is provided on the arm to assist in setting the required angle. For all normal operations the Table angle should be set at 0°.

IMPORTANT: TO ENSURE THAT THE DRILL IS ENTIRELY PERPENDICULAR TO THE TABLE: Insert a piece of straight round bar in the Chuck, place a square on the Table and raise the table to bring the square up to the round bar. Adjust the Table tilt if necessary so that the Table is correctly aligned.

4. Spin the Table about its axis by loosening the Table Locking Handle (D), as shown in Figure F

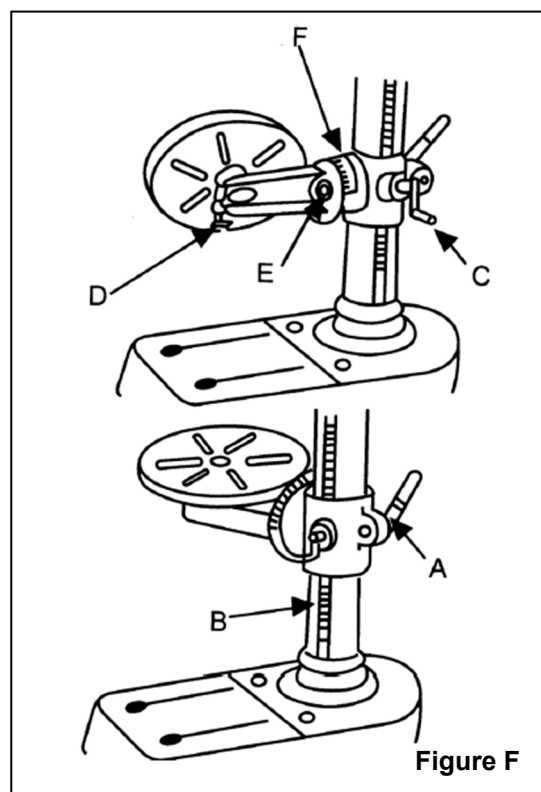

Figure F

CHANGING DRILL SPEED

1. Open the Pulley Cover.
2. Loosen the Belt Tension Lock Knobs on both sides of the Head and turn the Belt Tension Lever clockwise. This will bring the Motor Pulley towards the Spindle Pulley, removing all tension from the drive Belts.
3. Consult Figure G (or the chart inside the Pulley Cover) and install the Belts on the Pulleys in the positions that correspond to the required Spindle/Drill speed.
4. When the Belts have been correctly positioned, tighten them by turning the Belt Tension Lever counterclockwise. The tension is correct when the belts deflect by approximately 1/2" at their centers of run when using reasonable thumb pressure. (See Figure D on page 14.) Lock this position in with the two Belt Tension Lock Knobs. as shown in Figure D

Note: If a belt is too long to be properly tensioned, it must be replaced.

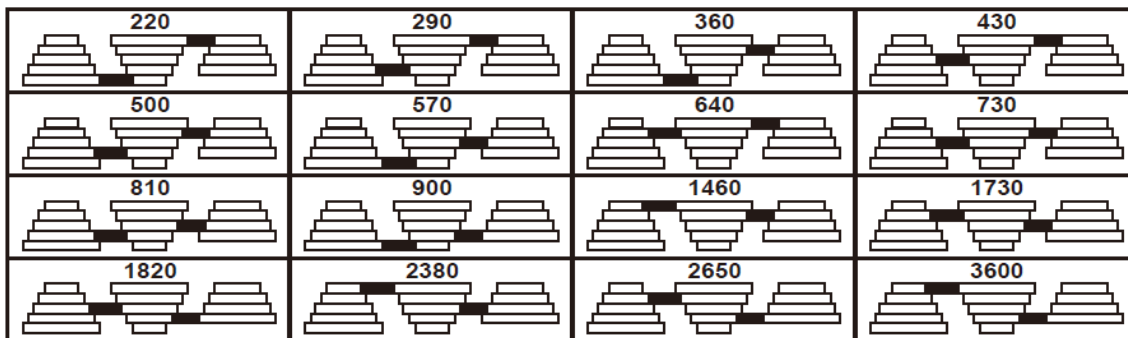
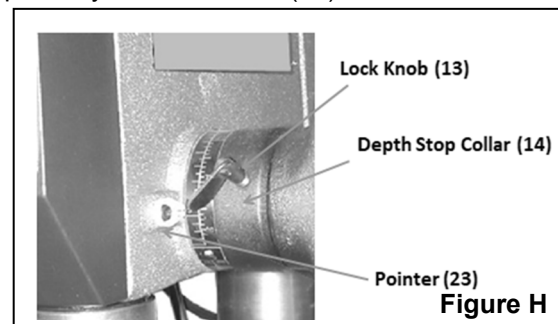

Figure G

SETTING THE DRILLING DEPTH

Located around the Spindle Feed Shaft is a Depth Stop Collar (14) carrying a graduated scale. The Collar will turn around the Shaft, and can be locked in place by the Lock Knob (13).

1. With the power to the Drill Press switched OFF, use the Spindle Feed Handles to lower the drill until the bit contacts the workpieces and hold it in that position.
2. Loosen the Lock Knob and turn the Depth Stop Collar so that the measurement for the required hole depth is aligned with the Pointer (23).
3. Tighten the Lock Knob to lock the Collar in this position. as shown in Figure H



USING THE CUTTING OIL DRIP SYSTEM

1. Remove the upper Oil Bottle from the Oil Bottle Clips and unscrew the Cap.
2. Make sure that the Oil Pipe valve is closed. Fill the Bottle with your lubricant of choice.
3. Screw the Cap onto the Bottle and snap the Bottle back into the Clips.
4. Open the Oil Pipe valve and adjust the Pipe so the oil drips onto the cutting area.
5. The used oil will collect in the Oil Bottle that is attached to the underside of the Work Table.
 - Dispose of the used oil in accordance with local regulations.

INSTALLING THE BIT

CAUTION! Wear heavy-duty work gloves to provide protection when inserting and removing drill bits. Drill bits become very hot during use. Do not remove a drill bit until it has cooled.

1. Loosen the Chuck with the Chuck Key until the jaws of the drill are opened enough to fit the drill bit.
2. Insert the drill bit approximately 1" into the jaws of the Chuck, ensuring that the jaws do not touch the flutes of the bit.
3. Hand tightens the Chuck until the bit is held securely in place. Confirm that the bit is centered between the Chuck jaws.
4. Use the Chuck Key to tighten the Chuck.
 - Insert the tip of the Chuck Key into a hole on the side of the Chuck so that the teeth on the Key engage the gear on the Chuck. Use the Key to tighten the Chuck securely and remove the Key.

NOTICE: Use sharp bits. Dull, bent, or damaged bits will cause stress on the drill and/or break.

USING THE LED LAMP

1. Flip the LED Lamp Power Switch (73) to turn the LED Lamp (72) on.
2. Use the Lamp's built-in goose-neck to move it to a position where it illuminates the workpiece in the area where it is being drilled.
3. Turn off the Lamp after use. Move the Lamp away from the Chuck before removing the drill bit and cleaning the tool.

WORKPIECE AND WORK AREA SET UP

1. Designate a work area that is clean and well lit. The work area must not allow access by children or pets to prevent distraction and injury.
2. Route the power cord along a safe route to reach the work area without creating a tripping hazard or exposing the power cord to possible damage. The power cord must reach the work area with enough extra length to allow free movement while working.
3. Secure loose workpieces using a vise or clamps (not included) to prevent movement while working.
4. There must not be objects, such as utility lines, nearby that will present a hazard while working.
5. Set the Table height and position so that the drill travel range is sufficient for the workpiece to be drilled.
6. Set the drilling depth (see Changing Drill Speed on page 14) so that the bit will not contact the table, or align the table so that the hole in its center is in line with the bit.
7. Make sure the workpiece is securely clamped. That is, held in a drill vise, or bolted to the table.
WARNING! Do not hold the workpiece with your bare hands while drilling. Serious injury may be caused if the workpiece is flung out of the operator's hand.
8. IF THE WORKPIECE IS IRREGULARLY SHAPED and cannot be laid flat on the table, securely block and clamp it. Any tilting, twisting or shifting will result not only in a roughly drilled hole but also increases the chances of damage to the drill.
9. FOR FLAT WORK, lay the workpiece on a wooden base and clamp it down firmly against the table to prevent it from turning.
10. FOR SMALL WORKPIECES that cannot be clamped to the table, use a drill press vise (not supplied). Clamp or bolt the vise to the table.
11. WHEN DRILLING COMPLETELY THROUGH WOOD, position a piece of scrap wood between the workpiece and the table to prevent splintering on the underside of the workpiece as the bit breaks through. Brace one end of the scrap wood against the left side of the column (as shown in Figure I). Securely clamp the other end of the scrap wood to the table.

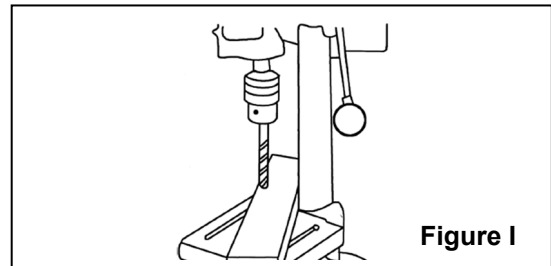

Figure I

GENERAL OPERATING INSTRUCTIONS

1. Use the Spindle Feed Handles to bring the drill bit down to where the hole is to be drilled. Make minor workpiece alignment adjustments as required.
2. Make sure that the Drill Press Power Switch is in the " Off " position, then plug the Power Cord into an electrical outlet.
3. Turn the Drill Press on.
4. Pull down on the Spindle Feed Handles and slowly drill the hole into the workpiece.
WARNING! If the drill bit grabs and spins the workpiece, do not attempt to stop the spinning with your hands. Step back, and turn the Drill Press off. Wait for the Spindle to stop turning before dislodging the workpiece.
5. To prevent accidents, turn off the tool and disconnect its power supply after use. Clean, then store the tool indoors out of children's reach.

Maintenance

⚠WARNING

- Turn the Power Switch of the tool off and unplug the tool from its electrical outlet before performing any procedure in this section.
- Do not use damaged equipment. If abnormal noise or vibration occurs, have the problem corrected before further use.
- If the supply cord of this power tool is damaged, it must be replaced only by a qualified service technician.

CLEANING AND LUBRICATION

BEFORE EACH USE

Inspect the general condition of the tool. Check for:

1. Loose hardware,
2. Misalignment or binding of moving parts,
3. Cracked or broken parts,
4. Damaged electrical wiring, and
5. Any other condition that may affect its safe operation.

AFTER USE

1. Wipe external surfaces of the tool with clean cloth.
2. Using compressed air, blow clean the Table, Base, and Motor cooling vents of dirt and materials.
3. Apply paste wax to the Table and Tube Column to enable movement and to help keep surfaces clean.
4. All bearings are factory lubricated and need no further attention.
5. Periodically, lubricate the Rack teeth,
6. Table gears and Spindle upper teeth.

BELT INSPECTION AND TENSIONING

1. Examine belt for cracks, tears in the backing, and other damage.
2. Replace belt if damaged, following the instructions under Installing the Belts on page 9.

SPINDLE FEED HANDLES ADJUSTED.

If the Spindle does not return all the way up or moves up sluggishly, or if it requires too much force to pull down on the Spindle Feed Handles, the amount of spring tension on the Spindle Feed Handles can be adjusted.

1. Loosen the Lock Knob on the Depth Stop Collar.
2. Move the Spindle/Chuck assembly to its uppermost position.
3. Turn the Depth Stop Collar clockwise until it stops, and tighten the Lock Knob to prevent the Spindle/Chuck assembly from dropping during Torsion Spring adjustment.
4. Insert a screwdriver in the lower-front notch of the Spring Cap (78) to hold it in place.
5. While holding the screwdriver in place, use a wrench to remove only the outer Nut (77).
6. With the screwdriver still in place, loosen the remaining (inner) Nut until the
 - Spring Cap notch disengages from the
 - Spring Retainer -- about 1/8 inch.
7. Turn the screwdriver counterclockwise and engage the next Spring Cap notch. Hold the screwdriver in place.
8. Tighten the inner Nut just enough to engage the Spring Cap notch.
Note: If this Nut is too tight, it will restrict the up-and down movement of the Spindle/Chuck assembly.
9. Remove the screwdriver, pull down on the Spindle Feed Handles and check the spring tension, making sure the up movement is smooth and complete.
 - From one inch down, the Chuck should return to its uppermost position. If more tension is required, repeat steps 4 through 9.
10. Replace the outer Nut and tighten it on top of the inner Nut. Do not overtighten.
11. If the up/down movement is restricted, slightly loosen the inner and outer Nuts, then retighten only the outer Nut.

Troubleshooting

⚠WARNING

- Follow all safety precautions whenever diagnosing or servicing the tool
- Disconnect power supply before service.

Failure	Possible Cause	Corrective Action
Tool will not start.	<ol style="list-style-type: none"> 1. Cord not connected. 2. No power at outlet. 3. Tool's thermal reset breaker tripped (if equipped). 4. Internal damage or wear. (Carbon brushes or switch, for example.) 	<ol style="list-style-type: none"> 1. Check that cord is plugged in. 2. Check power at outlet. If outlet is unpowered, turn off tool and check circuit breaker. If breaker is tripped, make sure circuit is right capacity for tool and circuit has no other loads. 3. Turn off tool and allow to cool. Press reset button on tool. 4. Have technician service tool.
Tool operates slowly.	<ol style="list-style-type: none"> 1. Extension cord too long or wire size too small. 	<ol style="list-style-type: none"> 1. Eliminate use of extension cord. If an extension cord is needed, use one with the proper diameter for its length and load.
Motor runs, but Spindle does not turn.	<ol style="list-style-type: none"> 1. Belt(s) improperly installed or missing. 	<ol style="list-style-type: none"> 1. Properly install belt(s). See Installing the Belts on page 9.
Performance decreases over time	<ol style="list-style-type: none"> 1. Accessory dull or damaged. 2. Carbon brushes worn or damaged. 	<ol style="list-style-type: none"> 1. Keep cutting accessories sharp. Replace as needed. 2. Have qualified technician replace brushes.
Excessive noise or rattling.	<ol style="list-style-type: none"> 1. Internal damage or wear. (Carbon brushes or bearings, for example.) 2. Belt (if equipped) too loose (slipping) or too tight (bearing damage). 	<ol style="list-style-type: none"> 1. Have technician service tool. 2. Properly tension belt.
Overheating.	<ol style="list-style-type: none"> 1. Forcing machine to work too fast. 2. Accessory dull or damaged. 3. Blocked motor housing vents. 4. Motor being strained by long or small diameter extension cord. 	<ol style="list-style-type: none"> 1. Allow machine to work at its own rate. 2. Keep cutting accessories sharp. Replace as needed. 3. Wear ANSI-approved safety goggles and NIOSH approved dust mask/respirator while blowing dust out of motor using compressed air. 4. Eliminate use of extension cord. If an extension cord is needed, use one with the proper diameter for its length and load.

Parts Diagram

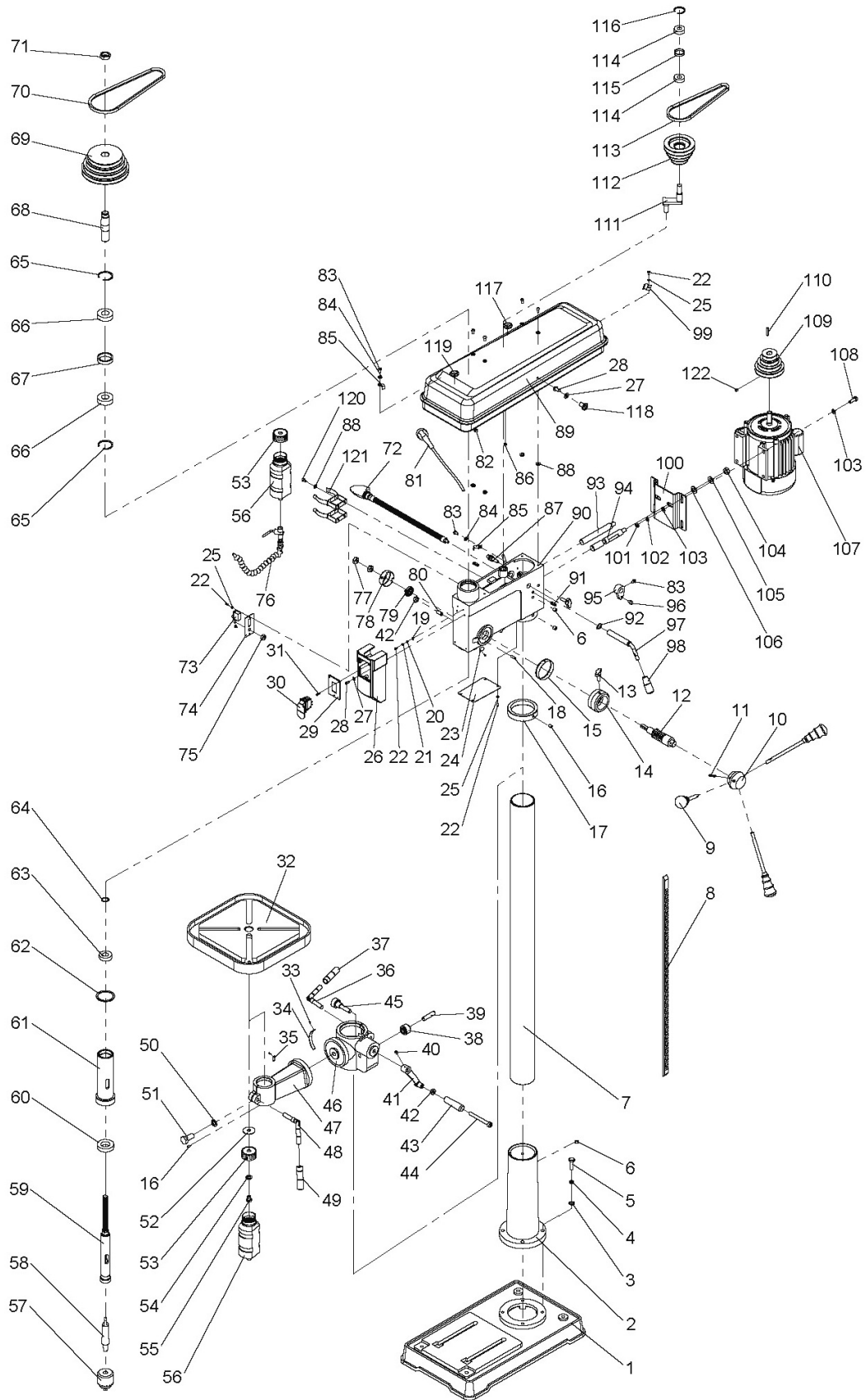

Parts List

Reference	Part Number	Part Description	Quantity
1	1	Base	1
2	2	Column Support	1
3	3	Flat Washer 10	4
4	4	Spring Washer 10	4
5	5	Bolt M10×35	4
6	6	Socket Head Cap Screw M10×10	4
7	7	Column	1
8	8	Rack	1
9	9	Spindle Feed Handle Bar	3
10	10	Spindle Feed Hub	1
11	11	Spring Pin 5×30	1
12	12	Spindle Feed Shaft	1
13	13	Lock Knob	3
14	14	Depth Stop Collar	1
15	15	Scale Label	1
16	16	Set Screw M6×10	2
17	17	Collar	1
18	18	Rivet	1
19	19	Toothed Washer 4	2
20	20	Flat Washer	2
21	21	Spring Washer 4	2
22	22	Screw M4×8	8
23	23	Pointer	1
24	24	Cover Plate	1
25	25	Flat Washer 4	7
26	26	Junction Box	1
27	27	Flat Washer 5	4
28	28	Cross-Shape Screw M5×8	4
29	29	Switch Panel	1
30	30	Drill Press Power Switch	1
31	31	Tapping Screw St3.5×10	3
32	32	Work Table	1
33	33	Rivet 2×3	5
34	34	Scale Label	1
35	35	"0"-Degree Label	1
36	36	Table Lock Handle	1
37	37	Handle Grip	1
38	38	Gear	1
39	39	Axis Pin	1
40	40	Set Screw M5×10	1
41	41	Table Crank	1
42	42	Nut M10	2
43	43	Table Crank Handle	1
44	44	Socket Head Cap Screw M8×90	1
45	45	Worm Gear	1
46	46	Table Support	1
47	47	Table Support Arm	1
48	48	Table Clamp	1
49	49	Table Clamp Handle	1
50	50	Spring Washer 16	1
51	51	Bolt M16×35	1
52	52	Sealing Gasket (B)	1
53	53	Oil Bottle Cap	2
54	54	Sealing Gasket (A)	1
55	55	Hollow Connecting Bolt	1
56	56	Oil Bottle	2
57	57	Chuck	1
58	58	Arbor	1
59	59	Spindle	1
60	60	Ball Bearing 6006	1
61	61	Spindle Sleeve	1
62	62	Rubber Ring	1
63	63	Ball Bearing 6004	1
64	64	Retainer Ring 19	1
65	65	Retainer Ring 47	2
66	66	Ball Bearing 6205	2
67	67	Bearing Spacer Ring	1
68	68	Spindle Housing	1
69	69	Spindle Pulley	1
70	70	V-Belt A-785	1

Reference	Part Number	Part Description	Quantity
71	71	Thin Nut M24×1.5	1
72	72	LED Lamp	1
73	73	LED Lamp Power Switch	1
74	74	LED Lamp Switch Panel	1
75	75	Nut M10x1.5	1
76	76	Oil Pipe	1
77	77	Nut M12x1.5	2
78	78	Spring Cap	1
79	79	Tension Spring	1
80	80	Screw	1
81	81	Power Cord	1
82	82	Nut M6	2
83	83	Cross-Shape Screw M6×10	3
84	84	Flat Washer 6	7
85	85	Wire Clamp(B)	3
86	86	Nut M4	3
87	87	Belt Tension Locking Knob	2
88	88	Rubber Pad	4
89	89	Pulley Cover	1
90	90	Machine Body (Head)	1
91	91	Spring Pin 8×20	1
92	92	Retainer 15	1
93	93	Jackstay (B)	1
94	94	Jackstay (A)	1
95	95	Cam	1
96	96	Pull Pin	1
97	97	Belt Tension Lever	1
98	98	Belt Tension Lever Handle	1
99	99	Wire Clamp(A)	4
100	100	Motor Base Plate	1
101	101	Nut M8	4
102	102	Spring Washer 8	4
103	103	Flat Washer 8	8
104	104	Nut M12	2
105	105	Spring Washer 12	2
106	106	Flat Washer 12	2
107	107	Motor	1
108	108	Bolt M8×25	4
109	109	Motor Pulley	1
110	110	Flat Key 5x25	1
111	111	Idler Pivot Shaft	1
112	112	Idler Pulley	1
113	113	V-Belt A-710	1
114	114	Ball Bearing 6202	2
115	115	Pulley Bushing	1
116	116	Retainer Ring 35	1
117	117	Protective Ring	2
118	118	Pulley Cover Handle	1
119	119	Protective Ring	1
120	120	Socket Head Cap Screw M6×10	4
121	121	Oil Bottle Clip	2
122	122	Motor Pulley Set Screw	1

Replacement Parts

- For replacement parts and technical questions, please call Customer Service at **1-800-222-5381**.
- Not all product components are available for replacement. The illustrations provided are a convenient reference to the location and position of parts in the assembly sequence.
- When ordering parts, the following information will be required: item description, item model number, item serial number/item lot date code, and the replacement part reference number.
- The distributor reserves the rights to make design changes and improvements to product lines and manuals without notice.

Limited Warranty

Northern Tool and Equipment Company, Inc. ("We" or "Us") warrants to the original purchaser only ("You" or "Your") that the Klutch product purchased will be free from material defects in both materials and workmanship, normal wear and tear excepted, for a period of **one year** from date of purchase. The foregoing warranty is valid only if the installation and use of the product is strictly in accordance with product instructions. There are no other warranties, express or implied, including the warranty of merchantability or fitness for a particular purpose. If the product does not comply with this limited warranty, Your sole and exclusive remedy is that We will, at our sole option and within a commercially reasonable time, either replace the product or product component without charge to You or refund the purchase price (less shipping). This limited warranty is not transferable.

Limitations on the Warranty

This limited warranty does not cover: (a) normal wear and tear; (b) damage through abuse, neglect, misuse, or as a result of any accident or in any other manner; (c) damage from misapplication, overloading, or improper installation; (d) improper maintenance and repair; and (e) product alteration in any manner by anyone other than Us, with the sole exception of alterations made pursuant to product instructions and in a workmanlike manner.

Obligations of Purchaser

You must retain Your product purchase receipt to verify date of purchase and that You are the original purchaser. To make a warranty claim, contact Us at 1-800-222-5381, identify the product by make and model number, and follow the claim instructions that will be provided. The product and the purchase receipt must be provided to Us in order to process Your warranty claim. Any returned product that is replaced or refunded by Us becomes our property. You will be responsible for return shipping costs or costs related to Your return visit to a retail store.

Remedy Limits

Product replacement or a refund of the purchase price is Your sole remedy under this limited warranty or any other warranty related to the product. We shall not be liable for: service or labor charges or damage to Your property incurred in removing or replacing the product; any damages, including, without limitation, damages to tangible personal property or personal injury, related to Your improper use, installation, or maintenance of the product or product component; or any indirect, incidental or consequential damages of any kind for any reason.

Assumption of Risk

You acknowledge and agree that any use of the product for any purpose other than the specified use(s) stated in the product instructions is at Your own risk.

Governing Law

This limited warranty gives You specific legal rights, and You also may have other rights which vary from state to state. Some states do not allow limitations or exclusions on implied warranties or incidental or consequential damages, so the above limitations may not apply to You. This limited warranty is governed by the laws of the State of Minnesota, without regard to rules pertaining to conflicts of law. The state courts located in Dakota County, Minnesota shall have exclusive jurisdiction for any disputes relating to this warranty.

KLUTCH

Distributed by:

Northern Tool & Equipment Company, Inc.

Burnsville, Minnesota 55306

www.northerntool.com

Made in **China**