

# KLUTCH

## Digital Display Drill Press

Owner's Manual



**! WARNING:** Read carefully and understand all ASSEMBLY AND OPERATION INSTRUCTIONS before operating. Failure to follow the safety rules and other basic safety precautions may result in serious personal injury.

Item #5793505

**READ & SAVE THESE INSTRUCTIONS**

Thank you very much for choosing a Klutch product!

For future reference, please complete the owner's record below:

Serial Number/Lot Date Code: \_\_\_\_\_

Purchase Date: \_\_\_\_\_

Save the receipt, warranty, and this manual. It is important that you read the entire manual to become familiar with this product before you begin using it.

This Digital Display Drill Press is designed for certain applications only. Northern Tool & Equipment is not responsible for issues arising from modification or improper use of this product such as an application for which it was not designed. We strongly recommend that this product not be modified and/or used for any application other than that for which it was designed.

For technical questions, please call **1-800-222-5381**.

**Table of Contents**

**Intended Use.....4**

**Packaging Contents.....4**

**Technical Specifications .....4**

**Important Safety Information .....5**

**Specific Operation Warnings .....7**

**Grounding .....9**

**Extension Cords.....10**

**Main Parts of Product.....11**

**Assembly Instructions.....12**

**Operating Instructions.....14**

**Maintenance .....18**

**Troubleshooting.....19**

**Parts Diagram.....20**

**Parts List.....20**

**Replacement Parts .....21**

**Limited Warranty .....22**

## Intended Use

Great workspace illumination and accuracy thanks to the integrated LED light and laser. Easy-to-read LCD display shows rpm as well as spindle travel for exact drilling depth. Parallel guide and vertical clamp on base. Superior control from two gears giving speed adjustment from 170 to 2600rpm. Convenient quick release.

## Packaging Contents

- Drilling Machine (1)
- Depth Stop (1)
- Base Plate(1)
- Clamping Lever (1)
- Chuck Guard (1)
- Guide / Stop (1)
- Handle (1)
- Screws 3.0 X 12 (2)
- Open-Ended Spanner (Flat) (1)
- Screw Bag (1)
- Operating Manual (1)
- Quick Release Clamp (1)
- Hex Key (1)

## Technical Specifications

Property	Specification
Motor Power	110V 60Hz 720W
Fuse Rating	13A
Base size	13in. X 12in.
Work Light	Integral Work Light with Laser Guide
Drilling Capacity (Chuck Size)	1/2in.
Number of Speeds	2
Variable Speed Range :	First : 170-880/min / Second : 490-2600/min
Collar Diameter	1-5/8in.
Column Diameter	1-7/8in.
Maximum Distance Spindle to Base	11in.
Spindle Travel	4in.
Swing	10in.

## Important Safety Information

### **⚠️WARNING**

- Read and understand all instructions. Failure to follow all instructions may result in serious injury or property damage.
- The warnings, cautions, and instructions in this manual cannot cover all possible conditions or situations that could occur. Exercise common sense and caution when using this tool. Always be aware of the environment and ensure that the tool is used in a safe and responsible manner.
- Do not allow persons to operate or assemble the product until they have read this manual and have developed a thorough understanding of how it works.
- Do not modify this product in any way. Unauthorized modification may impair the function and/or safety and could affect the life of the product. There are specific applications for which the product was designed.
- Use the right tool for the job. DO NOT attempt to force small equipment to do the work of larger industrial equipment. There are certain applications for which this equipment was designed. It will be a safer experience and do the job better at the capacity for which it was intended. DO NOT use this equipment for a purpose for which it was not intended.
- Industrial or commercial applications must follow OSHA requirements.

### **⚠️WARNING**

- This product may contain chemicals known to the state of California to cause cancer, birth defects, or other reproductive harm.
- Some dust created by power sanding, sawing, grinding, drilling, and other construction activities contains chemicals known to the state of California to cause cancer, birth defects, or other reproductive harm. Some examples of these chemicals are:
  - - lead from lead-based paints,
  - - crystalline silica from bricks and cement and other masonry products, and
  - - arsenic and chromium from chemically-treated lumber.
- Your risk from these exposures varies, depending on how often you do this type of work. To reduce your exposure to these chemicals: work in a well-ventilated area, and work with approved safety equipment, such as dust masks that are specially designed to filter out microscopic particles.
- Handling power cords on corded products may expose you to lead, a chemical known to the state of California to cause cancer and birth defects or other reproductive harm. Wash your hands after handling.

## **⚠️WARNING**

### **WORK AREA SAFETY**

- Inspect the work area before each use. Keep work area clean, dry, free of clutter, and well-lit. Cluttered, wet, or dark work areas can result in injury. Using the product in confined work areas may put you dangerously close to cutting tools and rotating parts.
- Do not use the product where there is a risk of causing a fire or an explosion; e.g., in the presence of flammable liquids, gases, or dust. The product can create sparks, which may ignite the flammable liquids, gases, or dust.
- Do not allow the product to come into contact with an electrical source. The tool is not insulated and contact will cause electrical shock.
- Keep children and bystanders away from the work area while operating the tool. Do not allow children to handle the product.
- Be aware of all power lines, electrical circuits, water pipes, and other mechanical hazards in your work area. Some of these hazards may be hidden from your view and may cause personal injury and/or property damage if contacted.

## **⚠️WARNING**

### **PERSONAL SAFETY**

- Stay alert, watch what you are doing, and use common sense when operating the tool. Do not use the tool while you are tired or under the influence of drugs, alcohol, or medication. A moment of inattention while operating the tool may result in serious personal injury.
- Dress properly. Do not wear loose clothing, dangling objects, or jewelry. Keep your hair, clothing and gloves away from moving parts. Loose clothes, jewelry, or long hair can be caught in moving parts. Air vents on the tool often cover moving parts and should be avoided.
- Wear the proper personal protective equipment when necessary. Use ANSI Z87.1 compliant safety goggles (not safety glasses) with side shields, or when needed, a face shield. Use a dust mask in dusty work conditions. Also use non-skid safety shoes, hardhat, gloves, dust collection systems, and hearing protection when appropriate. This applies to all persons in the work area.
- Do not overreach. Keep proper footing and balance at all times.

## **⚠CAUTION**

### **PRODUCT USE AND CARE**

- Do not force the product. Products are safer and do a better job when used in the manner for which they are designed. Plan your work, and use the correct product for the job.
- Check for damaged parts before each use. Carefully check that the product will operate properly and perform its intended function. Replace damaged or worn parts immediately. Never operate the product with a damaged part.
- Store the product when it is not in use. Store it in a dry, secure place out of the reach of children. Inspect the tool for good working condition prior to storage and before re-use.
- Use only accessories that are recommended by the manufacturer for use with your product. Accessories that may be suitable for one product may create a risk of injury when used with another tool. Never use an accessory that has a lower operating speed or operating pressure than the tool itself.
- Keep guards in place and in working order. Never operate the product without the guards in place.

## **Specific Operation Warnings**

### **⚠WARNING**

- DO NOT use the drill for a task it is not designed to perform and ensure operators are trained to use the drill.
- DO NOT operate the drill if any parts are damaged or missing as this may cause failure and/or personal injury.
- DO NOT operate the drill when you are tired or under the influence of alcohol, drugs or intoxicating medication.
- Keep children and unauthorized persons away from the work area.
- Keep hands and body clear of the drill bit when operating the drill.
- Maintain correct balance and footing. Ensure the floor is not slippery and wear non-slip shoes.
- DO NOT get the drill wet or use in damp or wet locations or areas where there is condensation.
- DO NOT use the drill where there are flammable liquids, solids or gases such as paint solvents and including waste cleaning rags etc
- Drill only one work piece at a time. Stacked multiple work pieces cannot be adequately clamped or braced and may bind on the drill bit or shift during cutting. Ensure the drill is mounted or placed on a level, firm work surface before use. A level and firm work surface reduces the risk of the drill becoming unstable
- Always use a clamp or a fixture designed to properly support round material such as rods or tubing. Rods have a tendency to roll while being cut, causing the drill bit to “bite” and pull the work with your hand into the drill bit.

- Let the drill bit reach full speed before contacting the work piece. This will reduce the risk of the work piece being thrown.
- If the work piece or drill bit becomes jammed, turn the drill off. Wait for all moving parts to stop and disconnect the plug from the power source. Then work to free the jammed material. Continued drilling with a jammed work piece could cause loss of control or damage to the drill.
- Never touch the drill bit or moving parts during use.
- Never start the drill when the drill bit is in contact with the work piece.
- The drill must be secured. A drill that is not properly secured may move or tip over and may result in personal injury.
- Keep your hands out of the drilling area while the tool is running. Contact with rotating parts or chips may result in personal injury.
- Make sure the drill bit is rotating before feeding into the work piece. Otherwise the drill bit may become jammed in the work piece causing unexpected movement of the work piece and personal injury.
- When the drill bit is jammed, stop applying downward pressure and switch off the tool. Investigate and take corrective actions to
- Eliminate the cause of the jam. Jamming can cause unexpected movement of the work piece and personal injury.
- LASER LIGHT. DO NOT stare into beam. Only turn laser beam on when tool is on work piece.
- Methods other than those specified here can result in dangerous radiation exposure.
- Never open the laser module. Unexpected exposure to the beam can occur.
- The laser may not be replaced with a different type of laser.
- Repairs of the laser may only be carried out by the laser manufacturer or an authorized representative.

## Grounding

### ⚠WARNING

- This machine must be grounded while in use to protect the operator from electrical shock. This unit is equipped with an electrical cord that has an equipment grounding conductor and a grounding plug. The plug **MUST** be plugged into a matching receptacle that is properly installed and grounded in accordance with ALL local codes and ordinances.
- **DO NOT MODIFY THE PROVIDED PLUG.** If it will not fit the receptacle, have the proper receptacle installed by a qualified electrician.
- **CHECK** with a qualified electrician or service person if you do not completely understand the grounding instructions, or if you are not sure the tool is properly grounded.

### Grounded Tools: Tools with 3-Prong Plugs

Tools marked with **Grounding Required** have a 3-wire cord and 3-prong grounding plug. The plug must be connected to a properly grounded outlet. If the tool should electrically malfunction or break down, grounding provides a low resistance path to carry electricity away from the user, reducing the risk of electric shock. (See Figure A.)

The grounding prong in the plug is connected through the green wire inside the cord to the grounding system in the tool. The green wire in the cord must be the only wire connected to the tool's grounding system and must never be attached to an electrically live terminal.

Your tool must be plugged into an appropriate outlet, properly installed and grounded in accordance with all codes and ordinances. The plug and outlet should look like those in the following illustration.

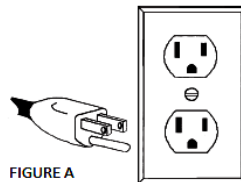

FIGURE A

### Double Insulated Tools: Tools with Two-Prong Plugs

Tools marked **Double Insulated** do not require grounding. They have a special double insulation system which satisfies OSHA requirements and complies with the applicable standards of Underwriters Laboratories, Inc., the Canadian Standard Association, and the National Electrical Code. (See Figure B.)

Double insulated tools may be used in either of the 120 volt outlets shown in the following illustration.

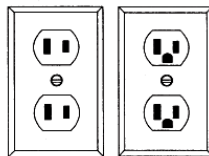

FIGURE B

## Extension Cords

### ⚠WARNING

- **USE A PROPER EXTENSION CORD.** Make sure your extension cord is in good condition. When using an extension cord, be sure to use one heavy enough to carry the current your product will draw. An undersized cord will cause a drop in line voltage, resulting in loss of power and cause overheating.
- Be sure your extension cord is properly wired and in good condition. Always replace a damaged extension cord or have it repaired by a qualified person before using it. Protect your extension cords from sharp objects, excessive heat and damp or wet areas.
- Grounded tools require a 3-wire extension cord. Double Insulated tools can use either a 2- or 3-wire extension cord.
- As the distance from the supply outlet increases, you must use a heavier gauge extension cord. Using extension cords with inadequately sized wire causes a serious drop in voltage, resulting in loss of power and possible tool damage.
- The smaller the wire's gauge number, the greater the capacity of the cord. For example, a 14-gauge cord can carry a higher current than a 16-gauge cord. Minimum extension cord wire size is shown in the following table:

Minimum Wire Size Of Extension Cords				
Nameplate AMPS	Cord Length			
	25'	50'	100'	150'
0-6	18 AWG	16 AWG	16 AWG	14 AWG
6-10	18 AWG	16 AWG	14 AWG	12 AWG
10-12	16 AWG	16 AWG	14 AWG	12 AWG
12-16	14 AWG	12 AWG	NOT RECOMMENDED	

- When using more than one extension cord to make up the total length, make sure each cord contains at least the minimum wire size required.
- If you are using one extension cord for more than one tool, add the nameplate amperes and use the sum to determine the required minimum cord size.
- If you are using an extension cord outdoors, make sure it is marked with the suffix **W-A** (**W** in Canada) to indicate it is acceptable for outdoor use.
- Make sure your extension cord is properly wired and in good electrical condition. Always replace a damaged extension cord or have it repaired by a qualified electrician before using it.
- Protect your extension cords from sharp objects, excessive heat, and damp or wet areas.

## Main Parts of Product

Subassembly
Display
Switch
Speed Control
Chuck Guard
Base Plate
Handle
Gear Selector Switch
Column
Quick Clamp

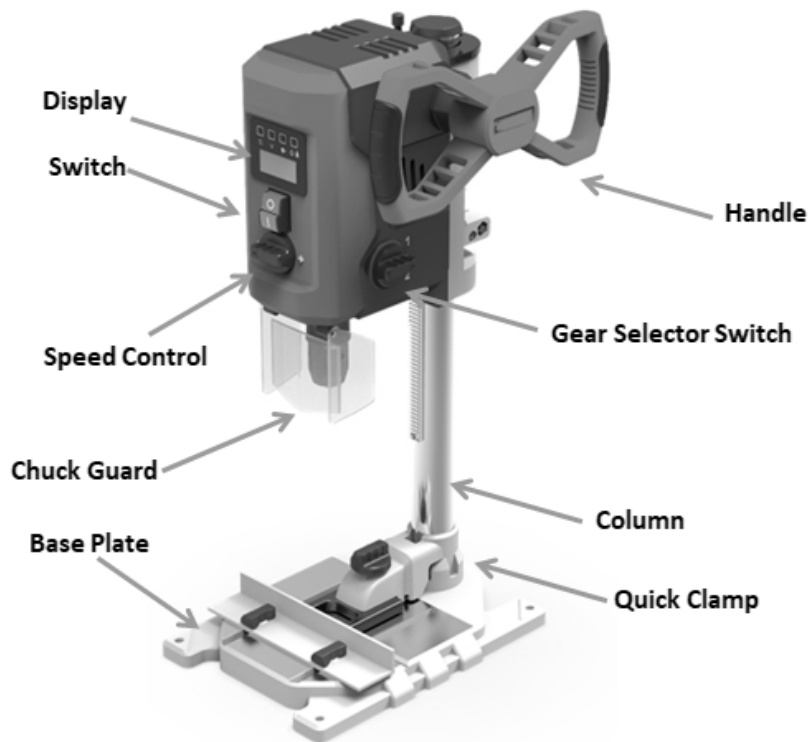

## Assembly Instructions

### ASSEMBLING THE BASE PLATE AND COLUMN

1. Insert the quick release clamp (2) over the column (3).
2. Locate the column (3) into the base plate (1) so as the guide pins on the bottom end of the column (3) engage with the grooves, on the bottom of the base plate (1).
3. Secure the grub screws (A) on the rear of the base plate (1) with the hex key (19). This may need a further adjustment on completion to align laser light to ensure centralization of the laser. (Fig. 1)

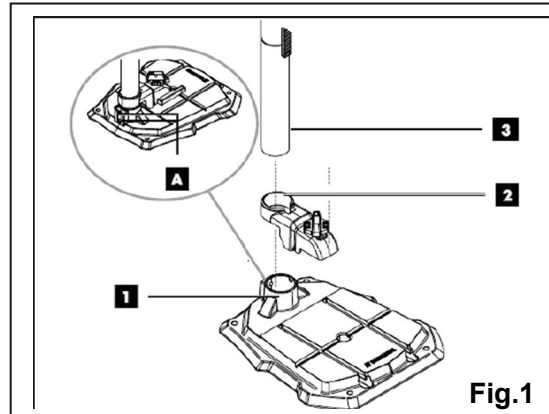

### FITTING THE GUIDE / STOP

1. Slide the guide / stop (16) into the grooves in the base plate (1).
2. Ensure that the sliding blocks underneath the winged screws of the guide / stop (15) are properly engaged in the grooves of the base plate.
3. Move the guide / stop (16) to the desired position and tighten the winged screws of the guide / stop (15) firmly. (Fig. 2)

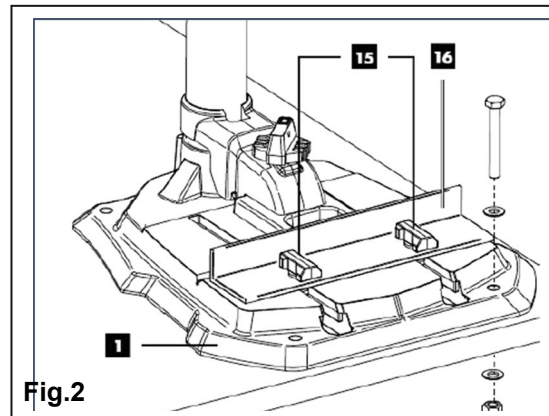

### FITTING THE CHUCK GUARD

5. Insert the chuck guard (13) into the holes provided in the machine frame
6. Fit the chuck guard (13) and tightening the screws (C). (Fig. 3)

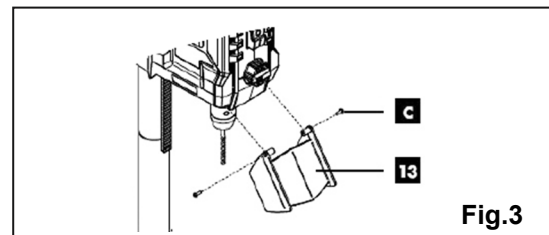

### HANDLE FITMENT

1. Slide the handle (8) onto the retainer (D).
2. Place the handle (8) on the retainer (D) with the flattened part at the side of the fastening screw (B).
3. Tighten the fastening screw (B) with the hex key (19). (Fig. 4)

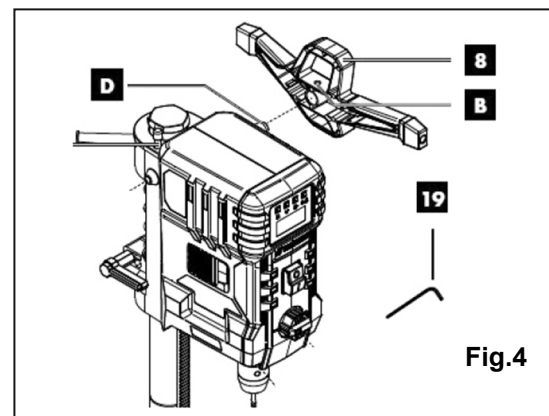

### **FITTING THE DEPTH STOP**

- 1 Insert the depth stop (7) into the hole provided in the housing. (Fig. 5)

### **CLAMPING LEVER FOR DEPTH STOP ASSEMBLY**

- 1 Assemble the clamping lever for depth stop (6) as shown in (Fig. 5)

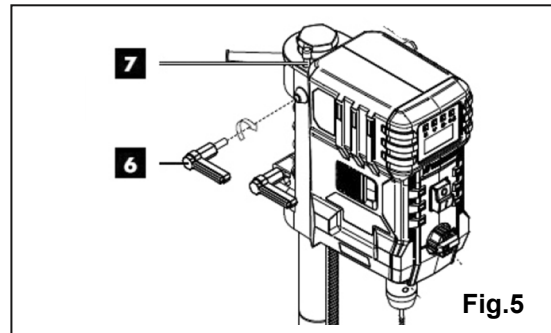

**Fig.5**

### **SECURING TO A WORK SURFACE**

- 1 Fasten the device to the work surface by bolting the base plate (1) to the work surface.

## Operating Instructions

### OPERATION OF THE DISPLAY

- 1 Switching the display on/off: Press the button one for five seconds until the display (9) switches on or off.
- 2 The display can be switched between displaying the speed and the drilling depth by pressing (F) button.
- 3 The zero point for the drilling depth can be set by pressing the (G) button.
- 4 The laser cross can be switched on or off by pressing the (H) button.
- 5 The LED work light can be switched on or off by pressing the (I) button.(Fig.6)

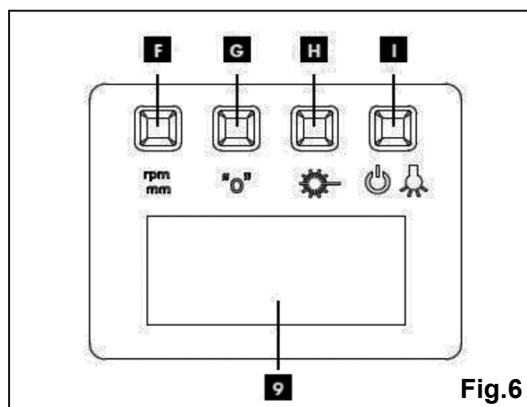

Fig.6

### HEIGHT ADJUSTMENT

- 1 The position of the machine head can be adjusted to suit the work piece by height or length.
- 2 Hold the handle (8) firmly.
- 3 Release the clamping (5) lever for the height adjustment.
- 4 Set the position of the machine head with the handle (8).
- 5 Secure the position of the machine head with the clamping lever for height adjustment (5).(Fig.7)

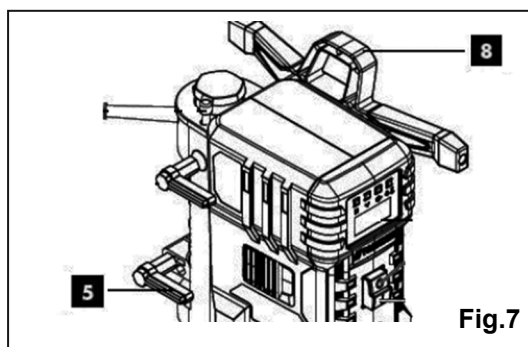

Fig.7

**NOTE:** Ensure in the lowest machine head position that the machine head will not be moved beyond the marking. Use the clamping lever for height adjustment (5) to secure the machine head in this position. Otherwise, the guide could be damaged.

### SETTING THE DRILLING DEPTH

- 1 The drilling depth can be set with the depth stop (7).
- 2 Release the clamping lever on the depth stop (6).
- 3 Carry out a test drilling. As soon as the desired depth is shown on the display (9), tighten the depth stop clamping lever (6) again.
- 4 The depth stop (7) is now locked in the desired drilling depth. (Fig.8)

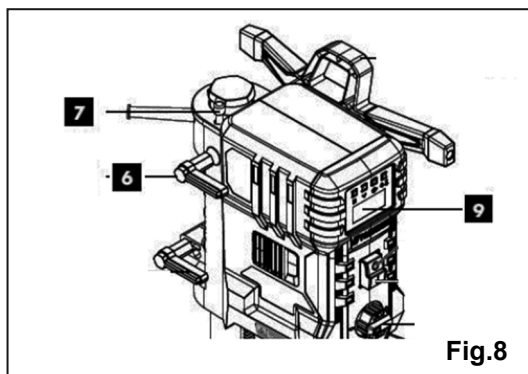
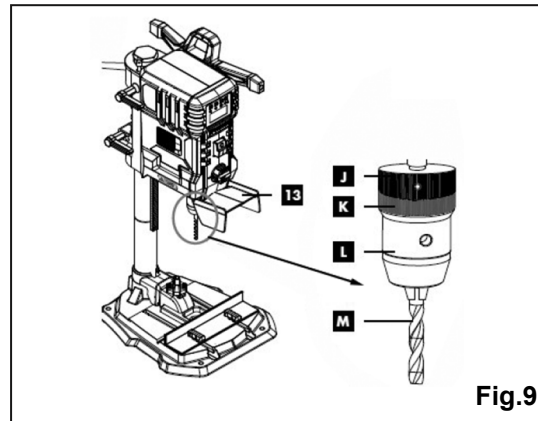

Fig.8

## CLAMPING

- 1 Hold the chuck in place and turn the securing ring (K) in the release direction.
- 2 Turn the clamping sleeve (L) clockwise until the drill bit (M) can be inserted. Hold the holding ring (J) in place whilst doing so.
- 3 Insert the drill bit (M), hold it in place and turn the clamping sleeve (L) counter clockwise by hand. Hold the holding ring (J) in place whilst doing so.
- 4 Hold the chuck in place and turn the securing ring (K) in the lock direction.(Fig.9)



NOTE: When using small drill bits, set the chuck to roughly the right size for the drill bit beforehand. Otherwise, there is a risk of the drill bit not being properly centred in the chuck.

## RELEASING

- 1 Turn the securing ring (K) in the "RELEASE" direction.
- 2 Turn the clamping sleeve (L) clockwise until the drill bit (M) can be removed.(Fig.7)

## ALIGNING WORK PIECES

- 1 Switch on the laser cross via the display (9). See **OPERATION OF THE DISPLAY..**
- 2 The intersection of the two laser lines exactly indicates the center point of the drill.
- 3 Align your marking on the work piece with the laser cross.

## CLAMPING THE WORK PIECE

- 1 Position the work piece with the help of the laser cross.
- 2 Loosen the quick clamping lever (17).
- 3 Place the quick clamp (2) on the work piece.
- 4 Turn the quick clamp lever (17) clockwise to clamp the work piece. Turn the quick clamp lever (17) counterclockwise to release, the quick clamp (2).(Fig.10)

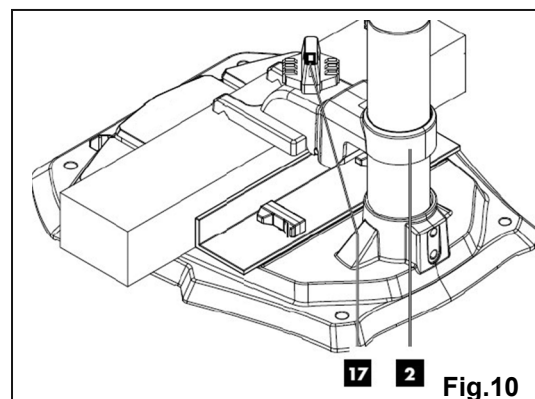

**NOTE** It must be possible to clamp the work piece securely. Do not work with work pieces that cannot be clamped securely. The cut out of the quick clamp must be centrally aligned with the hole to be drilled. Otherwise, the drill bit or the chuck could be obstructed by the quick clamp.

## CLAMPING LARGER WORK PIECES

- 1 Use the parallel stop (16) for larger work pieces:
- 2 Loosen the wing screws for the parallel stop (15) and insert the parallel stop (16) into the grooves of the base plate.
- 3 Tighten the wing screws for the parallel stop (15).
- 4 Align your work piece against the parallel stop (16) and clamp it with the quick clamp (2). (Fig.11)

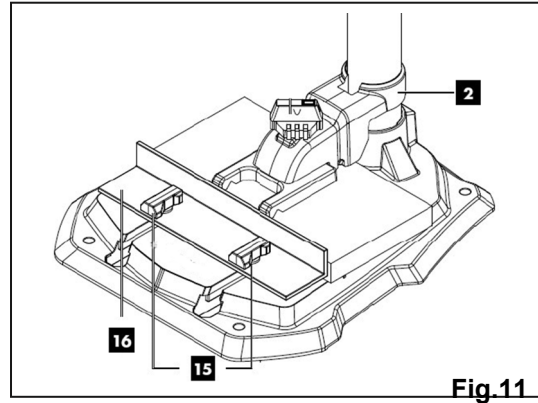

**NOTE:** With work pieces that are wider or longer than the tabletop, ensure that these are adequately supported, e.g. through trestles or saw horses. Work pieces that are longer or wider than the base plate of the tabletop drill can tip if they are not properly supported. If the work piece tips, this can damage the chuck guard or the cutting tool.

## SETTING THE DRILLING SPEED- MECHANICAL GEAR SELECTION

- 1 Two different speed ranges can be selected with the gear selector switch (18).
- 2 Low speeds first gear (170- 880 rpm) for large tool diameters.
- 3 High speeds second gear (490-2600 rpm) for small tool diameters.(Fig.12)

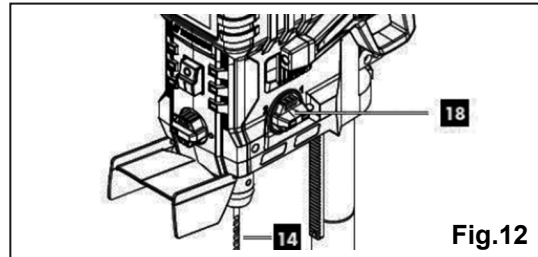

**NOTE:** Actuate the gear selector switch (18) only when at a standstill. If the gear selectors switch (18) does not latch into place turn the chuck (14) a little. If the gear selector switch (18) cannot be turned as far as the stop, turn the chuck a little with the drill.

## SETTING THE DRILLING SPEED- ELECTRONIC SPEED CONTROL

- 1 The speed of the individual gears can be seamlessly adjusted with the electronic speed control. Set the speed with the help of the speed control (12).The current speed can be seen on the display.(Fig.13)

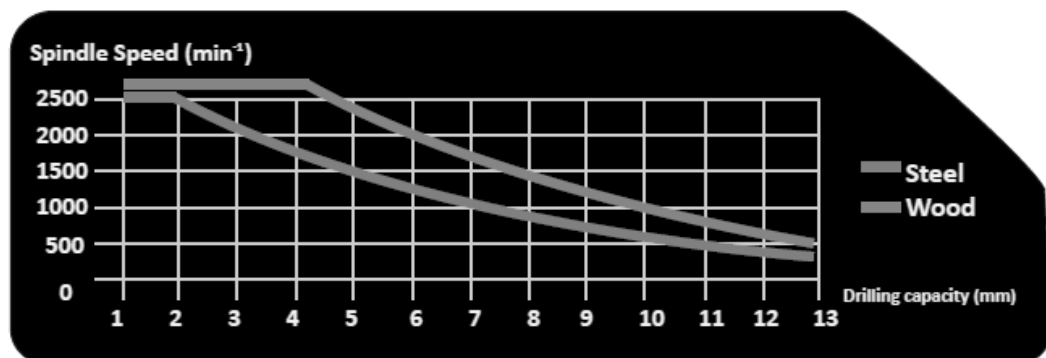
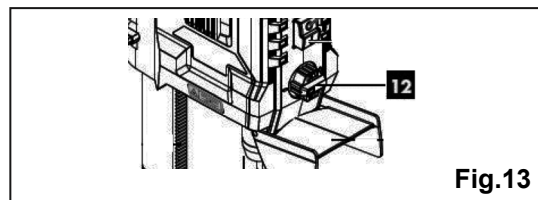

## DISPLAYING THE DRILLING DEPTH

- 1 Set the display (Fig 4.9) to the "Drilling depth" indication (button F).
- 2 Set the tip of the drill bit down lightly on the work piece.
- 3 Set the zero point by pressing the button (Fig. 6) Drill until the desired depth is shown on the display

## SWITCHING ON/OFF

- 1 Make sure that the chuck guard (13) is folded down before switching on.
- 2 Switching on: Press the on switch (11) to switch the device on.
- 3 Switching off: Press the off switch (10) to switch the device off.(Fig.14)

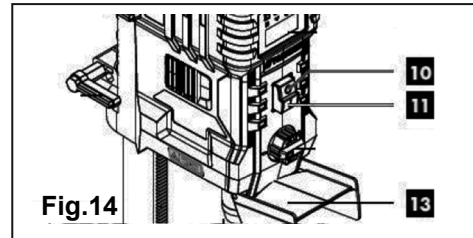

## DRILLING PROCEDURE

- 1 Align the work piece and clamp it.
- 2 Start the device and set the speed.
- 3 For drilling, move the handle (8) with uniform feed until the desired drilling depth is reached. When drilling into metal, interrupt the downward pressure briefly to break the swarf. After reaching the drilling depth, return the handle (8) to the starting position (5). Switch the device off.

## Maintenance

### **⚠WARNING**

- Pull out the mains plug before carrying out any adjustments, maintenance or repair work. Let the device cool down before all maintenance and cleaning tasks.
- To transport the device hold it by the base plate
- DO NOT oil the motor.
- DO NOT use corrosive agents for cleaning the plastic.
- Before using the device each time, check the device for obvious defects such as worn or damaged parts, correct seating of screws or other parts. Replace damaged parts.
- DO NOT: use cleaning agents or solvents. Chemical substances could damage the plastic parts of the device. Never clean the device under running water.

### **CLEANING**

- 1 Wipe swarf and dust off the machine from time to time with a cloth. Oil the rotating parts once monthly to extend the life of the tool.
- 2 Clean the device thoroughly after each use.
- 3 Clean the ventilation holes and the surface of the device with a soft brush or cloth.
- 4 Remove swarf, dust and dirt with a vacuum cleaner if necessary.
- 5 Lubricate the moving parts regularly.

### **REPLACING THE CHUCK**

- 1 Use an open-ended spanner (flat) 16 mm and one Hex key 2.5 mm (not included)
- 2 Loosen the Allen screw by turning it counterclockwise two turns. Hold the chuck shaft in place with the spanner and unscrew the chuck counterclockwise with your free hand.
- 3 Fasten the new chuck in reverse order.

**NOTE:** When replacing the chuck, use only chucks approved by the manufacturer.

## Troubleshooting

### ⚠WARNING

- Pull out the mains plug

Failure	Possible Cause	Corrective Action
Device does not start.	Motor, cable or plug defective, building circuit Breaker tripped.	Check power outlet, mains connection cable, mains plug. Have repair carried out by electrical specialist. Check building circuit breakers and fuses.
	On/off switch (11/10) defective.	Contact authorised Sealey Stockist.
	Motor defective.	Contact authorised Sealey Stockist.
Heavy vibrations.	Base plate (1) not fastened in place.	Secure machine by tightening.
Motor overheats easily.	Drill bit not clamped centrally.	Check drill bit in chuck (Fig1.14).
Motor overheats easily.	Overloading of the motor, insufficient cooling of the motor.	Avoid overloading the motor while drilling, Remove dust from the motor in order to ensure optimal cooling of the motor.
Motor makes excessive noise.	Coils damaged, motor defective.	Have checked by customer service department.

## Parts Diagram

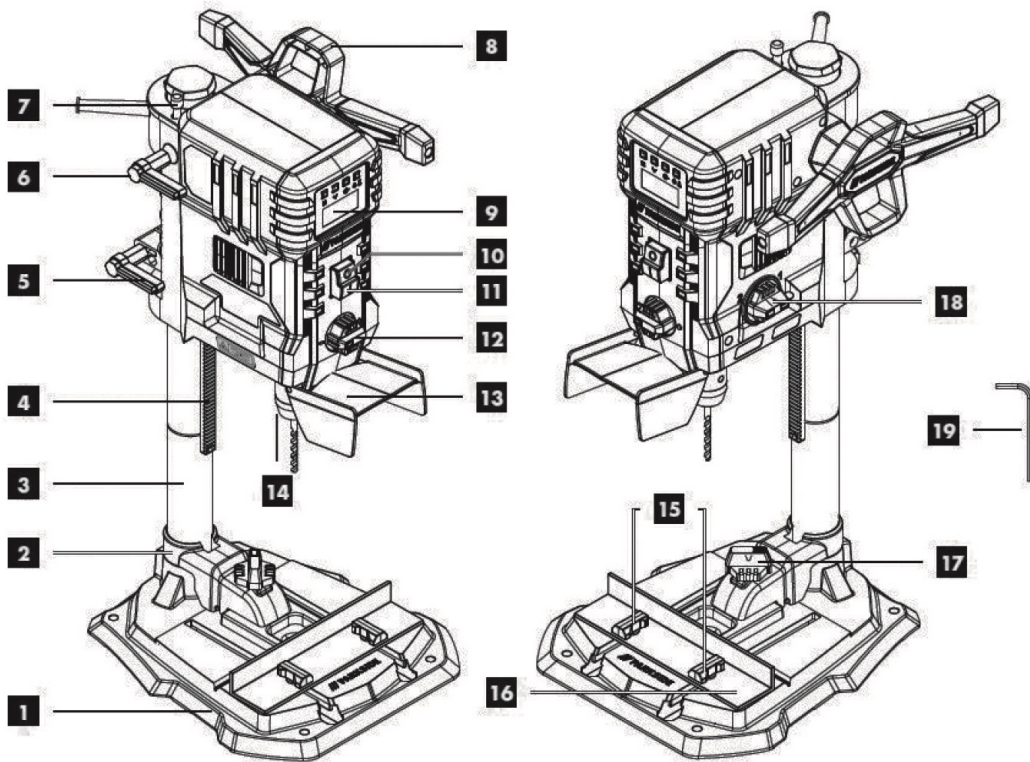

## Parts List

Reference	Part Number	Part Description	Quantity
1	1	Base plate	1
2	2	Quick clamp	1
3	3	Column	1
4	4	Toothed rack for height adjustment	1
5	5	Clamping lever for height adjustment	1
6	6	Clamping lever for depth stop	1
7	7	Depth stop	1
8	8	Handle	1
9	9	Display	1
10	10	Off switch	1
11	11	On switch	1
12	12	Speed control	1
13	13	Chuck guard	1
14	14	Chuck	1
15	15	Winged screws for guide / stop	1
16	16	Guide / stop	1
17	17	Quick clamp lever	1
18	18	Gear selector switch	1
19	19	Hex key	1

## Replacement Parts

- For replacement parts and technical questions, please call Customer Service at **1-800-222-5381**.
- Not all product components are available for replacement. The illustrations provided are a convenient reference to the location and position of parts in the assembly sequence.
- When ordering parts, the following information will be required: item description, item model number, item serial number/item lot date code, and the replacement part reference number.
- The distributor reserves the rights to make design changes and improvements to product lines and manuals without notice.

## Limited Warranty

Northern Tool and Equipment Company, Inc. ("We" or "Us") warrants to the original purchaser only ("You" or "Your") that the Klutch product purchased will be free from material defects in both materials and workmanship, normal wear and tear excepted, for a period of **one year** from date of purchase. The foregoing warranty is valid only if the installation and use of the product is strictly in accordance with product instructions. There are no other warranties, express or implied, including the warranty of merchantability or fitness for a particular purpose. If the product does not comply with this limited warranty, Your sole and exclusive remedy is that We will, at our sole option and within a commercially reasonable time, either replace the product or product component without charge to You or refund the purchase price (less shipping). This limited warranty is not transferable.

### Limitations on the Warranty

This limited warranty does not cover: (a) normal wear and tear; (b) damage through abuse, neglect, misuse, or as a result of any accident or in any other manner; (c) damage from misapplication, overloading, or improper installation; (d) improper maintenance and repair; and (e) product alteration in any manner by anyone other than Us, with the sole exception of alterations made pursuant to product instructions and in a workmanlike manner.

### Obligations of Purchaser

You must retain Your product purchase receipt to verify date of purchase and that You are the original purchaser. To make a warranty claim, contact Us at 1-800-222-5381, identify the product by make and model number, and follow the claim instructions that will be provided. The product and the purchase receipt must be provided to Us in order to process Your warranty claim. Any returned product that is replaced or refunded by Us becomes our property. You will be responsible for return shipping costs or costs related to Your return visit to a retail store.

### Remedy Limits

Product replacement or a refund of the purchase price is Your sole remedy under this limited warranty or any other warranty related to the product. We shall not be liable for: service or labor charges or damage to Your property incurred in removing or replacing the product; any damages, including, without limitation, damages to tangible personal property or personal injury, related to Your improper use, installation, or maintenance of the product or product component; or any indirect, incidental or consequential damages of any kind for any reason.

### Assumption of Risk

You acknowledge and agree that any use of the product for any purpose other than the specified use(s) stated in the product instructions is at Your own risk.

### Governing Law

This limited warranty gives You specific legal rights, and You also may have other rights which vary from state to state. Some states do not allow limitations or exclusions on implied warranties or incidental or consequential damages, so the above limitations may not apply to You. This limited warranty is governed by the laws of the State of Minnesota, without regard to rules pertaining to conflicts of law. The state courts located in Dakota County, Minnesota shall have exclusive jurisdiction for any disputes relating to this warranty.



# KLUTCH

Distributed by:

Northern Tool & Equipment Company, Inc.

Burnsville, Minnesota 55306

[www.northerntool.com](http://www.northerntool.com)

Made in **China**