

**SOLUTIONS TO SIMPLIFY YOUR WORKLOAD**  
Drum Handling, Material Handling, Storage & Specialized Equipment

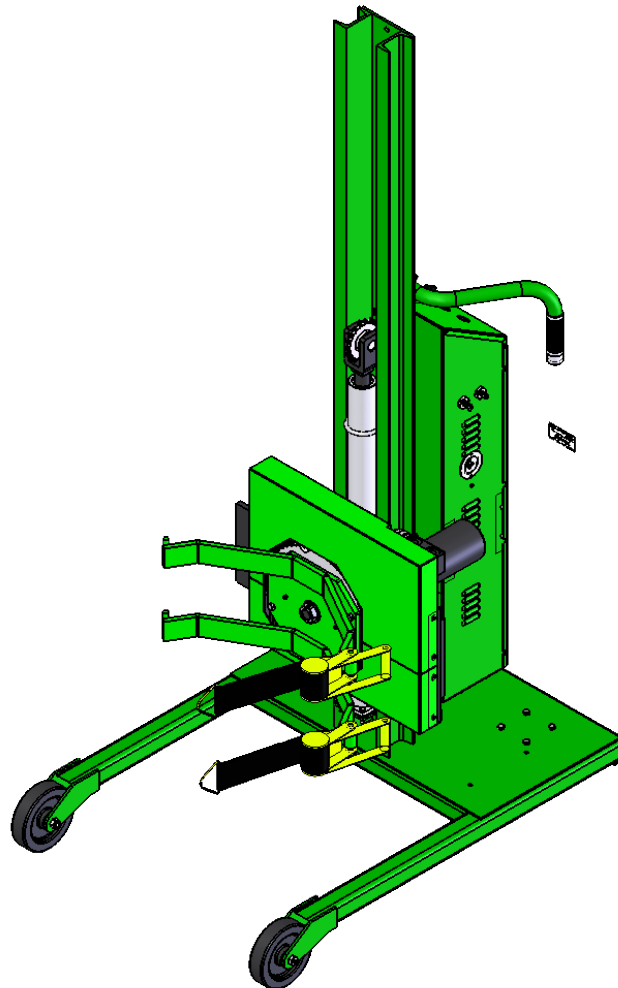

**BATTERY POWERED ROTOLIFT  
F88565C7 & F88566C6**



# BATTERY POWERED ROTOLIFT

## **Notice to Purchaser**

All statements, technical information, and recommendations related to Valley Craft's products are based on information believed to be reliable, but the accuracy or completeness is not guaranteed. Before using this product, you must determine if it is suitable for your intended application or situation. You assume all risks and liability associated with such use or implementation.

## **Product Testing**

We perform vigorous in-house safety and durability testing to ensure that the performance of our products meets the demands of the workplace. We also expect the same from manufacturers who supply components for our products. We do this to ensure that Valley Craft is a name that our customers trust and associate with quality.

## **Publication Revision Notice**

Following is a history of changes to this publication, including the current revision.

Previous Revisions: REV D (9/15) REV C (07/11)

Current Revision: Z41493A0 REV E

## **Copyright Notice**

© Valley Craft, Inc. All rights reserved. No part of this publication may be reproduced, photocopied, stored on a retrieval system, or transmitted without the express written consent of Valley Craft.

## **Trademarks**

The Valley Craft logo is a Valley Craft Trademark. All other company or product names are trademarks or registered trademarks of their respective owners. Use of a term in this document should not be regarded as affecting the validity of any trademark or service mark.

# BATTERY POWERED ROTOLIFT

## ■ Table of Contents

---

<b>Safety</b> .....	<b>4-6</b>
• Safety Overview .....	4
• Safety Message Conventions.....	5
• Material Safety Data .....	6
<b>Product Description</b> .....	<b>7</b>
• Specifications .....	7
• Features .....	7
<b>Unpacking and Assembly</b> .....	<b>8</b>
• Receiving and Inspection .....	8
<b>Operation</b> .....	<b>8</b>
• Operating Procedures .....	8
<b>Maintenance and Adjustments</b> .....	<b>9-10</b>
• Maintenance and Adjustment Procedures.....	9
• Charging Battery .....	10
<b>Troubleshooting</b> .....	<b>11</b>
• Troubleshooting Procedures .....	11
<b>Replacement</b> .....	<b>12</b>
• Replacement Procedures .....	12
<b>Parts List</b> .....	<b>13-20</b>
• Rotolift Isometric & BOM .....	13-14
• Backplate Assy & BOM .....	15
• Control Box & BOM .....	16-17
• Front Section & BOM .....	18-19
• Hydraulic Power Unit.....	20
<b>Equipment Drawings</b> .....	<b>21-22</b>
• Hydraulic Schematic.....	21
• Electrical Diagram .....	22
<b>Warranty Information</b> .....	<b>23</b>
• Warranty and Limitation of Liability.....	23
• Technical Assistance/Warranty Procedure.....	23

# BATTERY POWERED ROTOLIFT

## Safety

*Read and understand all safety information and become familiar with all safety symbols contained in this section before moving, operating or performing maintenance on this equipment.*

### ■ Safety Overview

The following general safety precautions must be observed during all phases of operation, service, and repair of this equipment. Failure to comply with these precautions or with specific safety messages elsewhere in this manual may impair the protection provided by the equipment. Such noncompliance would also violate safety standards of design, manufacture, and intended use of the instrument.

- Observe all safety signs posted in your facility.
- Observe warnings, cautions, handling information, storage requirements and other information on all container labels.
- Wear safety glasses with side shields.
- Wear the proper protective clothing, gloves and other protective equipment before handling any chemicals.
- Group the containers for the move by Hazard Class. Do not move acids with toxics, or oxidizers.
- Use maximum care and good judgment in preventing accidents and injuries and seeking first aid.
- Report unsafe conditions, equipment, practices, and on-job injuries.
- Understand your supervisor's instructions. Ask questions if you do not know how to do the job safely.
- Do not engage in tasks which you believe might be unsafe without consulting your supervisor.
- Clean up the work area and equipment upon job completion.
- Before you start work on any electrical system or circuit, check all power sources to ensure that the system or circuit is de-energized.
- Know the hazardous or potentially hazardous substances you work with or are present in your work area. Review Material Safety Data Sheets (MSDS) on these substances, or contact your supervisor.

# BATTERY POWERED ROTOLIFT

## ■ Safety Message Conventions

There are three types of safety notices that may be contained in this manual: **Danger**, **Warning** and **Caution** notices. These notices precede the procedural step or portion of text that presents the safety hazard.



### **DANGER**

---

- **DANGER** indicates an imminently hazardous situation which, if not avoided, will result in death or serious injury. This signal word is to be limited to the most extreme situations.
- 



### **WARNING**

---

- **WARNING** indicates a potentially hazardous situation which, if not avoided, could result in death or serious injury.
- 



### **CAUTION**

---

- **CAUTION** indicates a potentially hazardous situation which, if not avoided, may result in minor or moderate injury. It may also be used to alert against unsafe practices
- 
- When transporting a load, it is recommended that the attachment is lowered as close to the floor as possible to reduce the chances of accidents during transport.
  - Do not leave load suspended for an extended period of time or premature wear to the lifting cylinder will occur.
  - Maximum lifting capacity is 800 pounds.

# BATTERY POWERED ROTOLIFT

## ■ Material Safety Data Sheets (MSDS)

A Material Safety Data Sheet (MSDS) provides information on the safe use, handling and potential hazards of a product. This information assists with the proper response in the event of an emergency.

Valley Craft maintains material safety data sheets (MSDS) on all our products. You are urged to obtain copies of the relevant MSDS before using our products to protect yourself and others against any known health or safety hazards described in the MSDS. Valley Craft strives to make safety a top priority. Do not hesitate to contact us to discuss any safety aspects of our products.

**The relevant MSDS codes are listed below.**

- [www.conocophillips.com](http://www.conocophillips.com)  
Super ATF Transmission Oil, MSDS Code 778846  
Super-Sta Grease, MSDS Code 775440
- [www.batteriesplus.com](http://www.batteriesplus.com)  
Sealed Lead Acid Battery  
SLA for the English version  
SLA Sp for the Spanish version
- [Paint](#)  
Contact Valley Craft Customer Services at 1-800-328-1480 or on the web at [customer@valleycraft.com](mailto:customer@valleycraft.com)

## ■ Additional Safety Information

As with any mechanical device, care must be taken during the installation, operation, and maintenance of the device in order to realize the maximum benefit from its ownership.

**Note:** All personnel involved in the use and maintenance of this device should be thoroughly familiar with the information contained in this manual. Furthermore, it is recommended that all personnel be given adequate instruction and a sufficient period of training in its actual use to insure safety of personnel and proper care of the equipment. It is suggested that the units be initially operated empty until becoming familiar with how the unit handles.

# BATTERY POWERED ROTOLIFT

## Product Description

The **Rotolift** drum handler is a manually-propelled straddle-type unit that centers the load between the wheels for maximum balance and safety. Lifts and Rotates 360 degrees.

## ■ Specifications

The **Rotolift** specifications are shown in Table 1.

*Table 1. Specifications*

<b>Dimensions</b>	<b>Height: Depends on Model Width: 42.5 in. Depth: 46.5 in.</b>
<b>Weight</b>	<b>Depends on Model</b>
<b>Load Capacity</b>	<b>800 lbs</b>
<b>Power</b>	<b>12v</b>
<b>Lift Travel</b>	<b>58" or 71"</b>
<b>Rotation</b>	<b>360 degrees continuous</b>
<b>Wheels</b>	<b>Caster 3 x 1 1/16 Polyolefin Wheel 3 x 1 ¼ polyurethane</b>

## ■ Features

The **Rotolift** offers state-of-the-art design with many advanced features.

- 12 volt deep cycle battery
- Maintained contact switch (Rotate Switch)
- Rear swivel polyolefin casters with front polyurethane wheels

# BATTERY POWERED ROTOLIFT

## ■ Receiving and Inspecting

When unpacking this equipment, inspect the equipment for damage or mishandling. If damage is noted, file a damage claim with the carrier within 24 hours and call Valley Craft at 1-800-328-1480. Do not attempt to use the equipment.

Compare the contents of the shipment with the bill of lading. Report any missing items to the carrier and to Valley Craft immediately.

## ■ Operating Procedures

Only authorized personnel are permitted to use the **Rotolift**. Every load and every situation is different. Every lift must be evaluated and planned. Observe the following procedures when using this equipment.

**IMPORTANT!** Remove solid plug on hydraulic reservoir and install breather cap (included in the Power Pak) for proper air venting.

- Install battery with the negative pole on the left hand side (do not allow ground wire to come in contact with any other wires or a short will occur).
- Loosen rotator straps in the following way. A) Depress “finger release” on ratchet and fold handle open. B) Pull strap through ratchet just far enough to unhook metal ring from T-bar at the end of the rotating arm. C) Perform this on both ratchets.
- Move the Roto-Lift forward, straddling the drum, and center the rotating arms to the drum using the “up/down” switch on the control box panel.
- After arms are centered on drum, push unit forward the rest of the way so the drum touches the rear of the rotating arms.
- Pull both straps around the front of the drum and hook the metal ring onto the T’bar on the end of the rotating arms.
- By depressing the “finger release” on the ratchet and returning it to the original position, you may now ratchet the straps tight around the drum.
- With BOTH straps tight, raise the drum by using the “up” function switch.
- To dump, raise the drum to the desired height and rotate the switch on the control box panel the direction you want the drum to dump.

# BATTERY POWERED ROTOLIFT

## Maintenance and Adjustments

### ■ Maintenance and Adjustment Procedures

To keep this equipment operating properly, timely maintenance and adjustments are required. These procedures should be performed only by qualified personnel who are familiar with the equipment. Ensure dumper is disconnected from power and chute is in down position prior to inspecting and performing maintenance and adjustment procedures.

Maintenance and adjustment procedures are shown in Table 2.

*Table 2. Maintenance and Adjustment Procedures*

Component	Frequency	Operation	Procedure
Bearings / Pivot Points	Monthly	Grease	Apply grease as required
Hydraulic Fluid Level	Monthly	Visually inspect	Should fluid level become low or appear dirty or "milky", replace fluid with Super ATF Transmission fluid. Fluid level should be approximately 1-1/2" below fill hole.
Structural components	Monthly	Visually inspect	Replace as required
Hydraulic System	Monthly	Visually Inspect	Inspect for leaks and damaged hydraulic lines and correct as required
Electrical System	Monthly	Visually Inspect	Inspect for damaged or frayed wires and correct as required

Check hydraulic fluid every 40 hours or before using the machine after long set-aside periods. Three quarts of hydraulic fluid is sufficient to operate the system properly. Do not overfill. Use Dexron automatic transmission fluid only!

The lifting chain should be oiled periodically as needed. This is best accomplished by lowering the backplate completely and spraying lubricant onto the chain.

Check nylon straps occasionally for wear and replace as necessary.

# BATTERY POWERED ROTOLIFT

## ■ Charging Batteries

---

1. Always turn the key to the “off” position when unit is not in use.
2. To charge your battery, plug a grounded extension cord into the built-in receptacle in the Control Box and an outlet.
3. The battery will charge automatically after the charger is plugged in and can be left unattended.
  - Batteries will generally require equal charging to work time.
4. Keep the charger plugged in to maintain a full battery level when the unit is not being used.

### NOTES:

- See charger **MANUAL** for **SAFETY PRECAUTIONS** and charger **TROUBLESHOOTING**.
- **DO NOT USE BATTERIES UNTIL THEY ARE TOTALLY DISCHARGED.**
  - i. Doing so may damage your battery.
  - ii. For maximum battery life, your unit is equipped with a charger that collects information from the battery and adjusts the current and voltage accordingly. If your battery voltage drops below a certain threshold the charger will not charge the battery.
- If the battery becomes discharged and won't charge by ordinary means, a suggested solution is to “trick” the charger into reading a higher voltage from the battery. To do this connect a second, well-charged battery (12.4 volts or greater) in parallel with the dead battery-positive to positive, negative to negative. Then plug in your charger and charge the combination until the dead battery has enough voltage to enable being charged by itself.

# BATTERY POWERED ROTOLIFT

## Troubleshooting

### ■ Troubleshooting Procedures

If troubleshooting or maintenance should be required, it should be performed only by qualified personnel trained to perform such procedures. .

*Table 3. Trouble Shooting Procedures*

Problem	Possible Cause	Corrective Action
Batteries won't charge	Faulty Battery(s)	Load test Batteries to ensure it is good. If battery is bad see page 12 for replacement.
	Not following recharging directions	Refer to Battery Charging Instructions (Page 10)
	Improper grounding/wiring	Tighten Charger mounting bolts and check wiring
Unit not functioning	Low/Dead Batteries	Recharge Batteries
	Improper grounding	Check Motor & Battery wire connections. Tighten if necessary
	Damaged or loose wiring	Check wiring to switches in Control Box. Re-attach loose connections.
	Bad Switches	Call factory for replacement

# BATTERY POWERED ROTOLIFT

## Replacement

### ■ Replacement Procedures

Occasionally, it will be necessary to replace a part that has been Damaged or worn. Many parts on this Rotolift are replaceable. If Replacement of a part is required, it should be performed only by Qualified personnel who are familiar with the equipment.

See Sheet 11-18 for available replacement parts. Identify the part number you need. Contact Valley Craft Customer Service at 1-800-328-1480 or on the Web at [customer@valleycraft.com](mailto:customer@valleycraft.com).

Information required when contacting Valley Craft:

- A. Company name and address
- B. Contact persons name
- C. Telephone number
- D. E-Mail address
- E. Model Number
- F. Date of manufacture
- G. Part number of Parts ordering

The model number and date of manufacture is stamped on a metal tag located on the back side of the frame just above the push handle.

# BATTERY POWERED ROTOLIFT

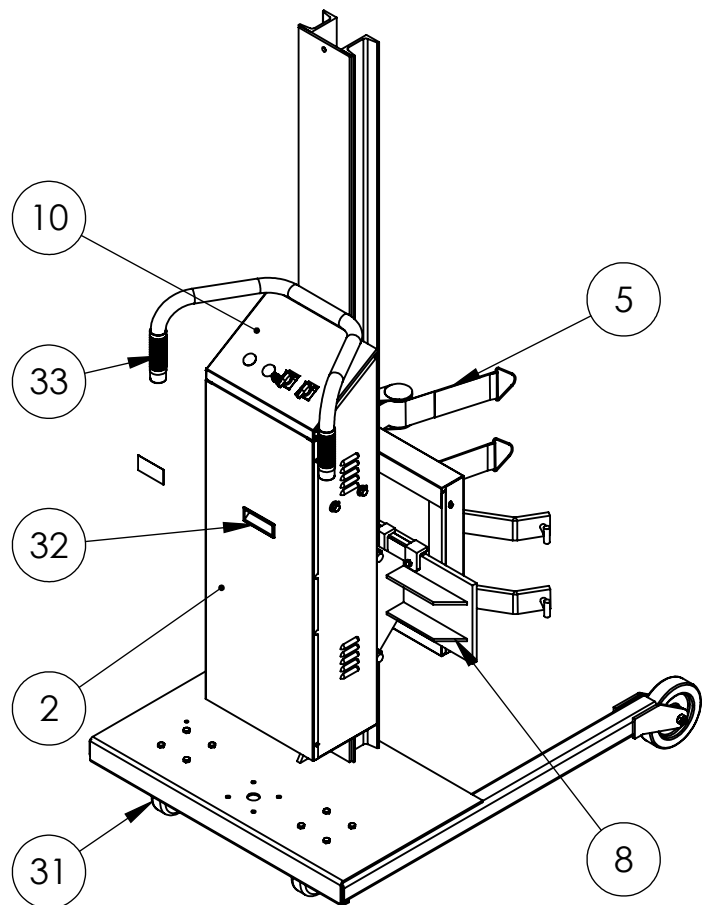
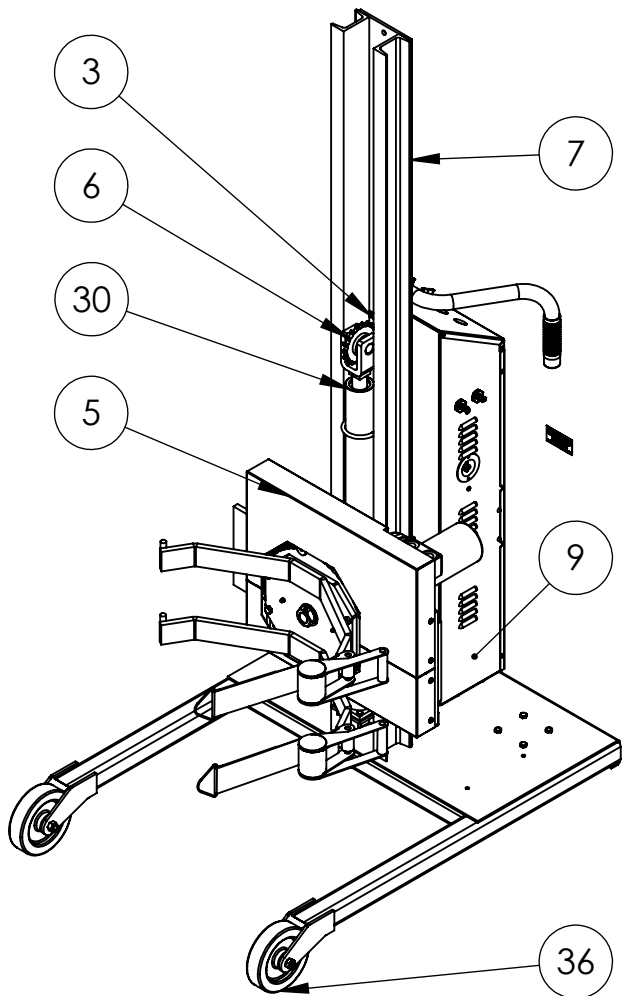

ROTO-LIFT SHOWN  
IS F88565C7

**ROTOLIFT-78/SAE**

ITEM NO.	PART NUMBER	DESCRIPTION	QTY.
1	F52067A6	PIN-CLEVIS 1.00X2.375 (KANBAN)	1
2	F58825A8	FRT-CTRL BOX	1
3	F60860A8	RLR CHAIN ASSY-78	1
4	F61306A3	PP-4SOL/3PORT 12V	1
5	F62848B1	FRT SECT ASSY SAE/ROTO	1
6	F63091A3	SPROCKET ASSY-50C18 BRG 1.01 (purchased)	1
7	F64331A0	SL WLDMT-78	1
8	F64367A4	BACK PL ASSY	1
9	F68725A5	CTRL BOX ASSY/SL MOD	1
10	F68730A0	PANEL ASSY ROTO-LIFT	1
11	Z00172A5	BATTERY-12V 80AH SEALED LEAD	1
12	Z10036A6	NUT-HEX KEPS 5/16-18	10
13	Z10043A7	NUT-NYL NE 1/4-20	2
14	Z10072A1	PIN-SPG 1/4X1-1/2	1
15	Z10113A2	S-HHC 1/4-20X1-1/4	2
16	Z10122A1	S-HHC 5/16-18X3/4	2
17	Z10123A0	S-HHC 5/16-18X1	8
18	Z10132A9	S-HHC 3/8-16X1	2
19	Z10186A4	S-SHC 1/4-20X1/2 GR8	4
20	Z10201A5	WASHER-5/16 FLAT USS	2
21	Z10207A9	WASHER-1/4 LOCK INT TOOTH	4
22	Z10213A1	WASHER-5/16 LOCK MD	2
23	Z10214A0	WASHER-3/8 LOCK MD	2
24	Z10241A7	BOLT-U 5/16-18 X 2-1/2	1
25	Z20243A4	FTG PIPE BULKHEAD 1/4 MPT x.92	2
26	Z10385A3	S-PTHTC #8x3/8 LG	8
27	Z20586A6	FTG 90 2501-4-4	2
28	Z20600A2	FTG STR 2404-4-4	2
29	Z41156A5	LABEL-VALLEYCRAFT PAPER	1
30	Z20753A0	CYL ASSY-78 SAE	1
31	Z30228A2	CSTR-4X1-1/2 SWL PCI	2
32	Z30415A5	HDL PCKT PULL PLST 3.25X1.41	1
33	Z50085A2	GRIP-HDL 1-1/4" BLK	2
34	F68993	AXLE BOLT ASSY/SL (KANBAN)	2
35	Z10048A2	NUT-NYL NE 1/2-13	2
36	Z31606A9	WHL-6 x 1-1/2 PCI, W/BUSHING	2
37	Z20810A3	HARNESS-PUMP -/POWER DRIVE	1

## BATTERY POWERED ROTOLIFT

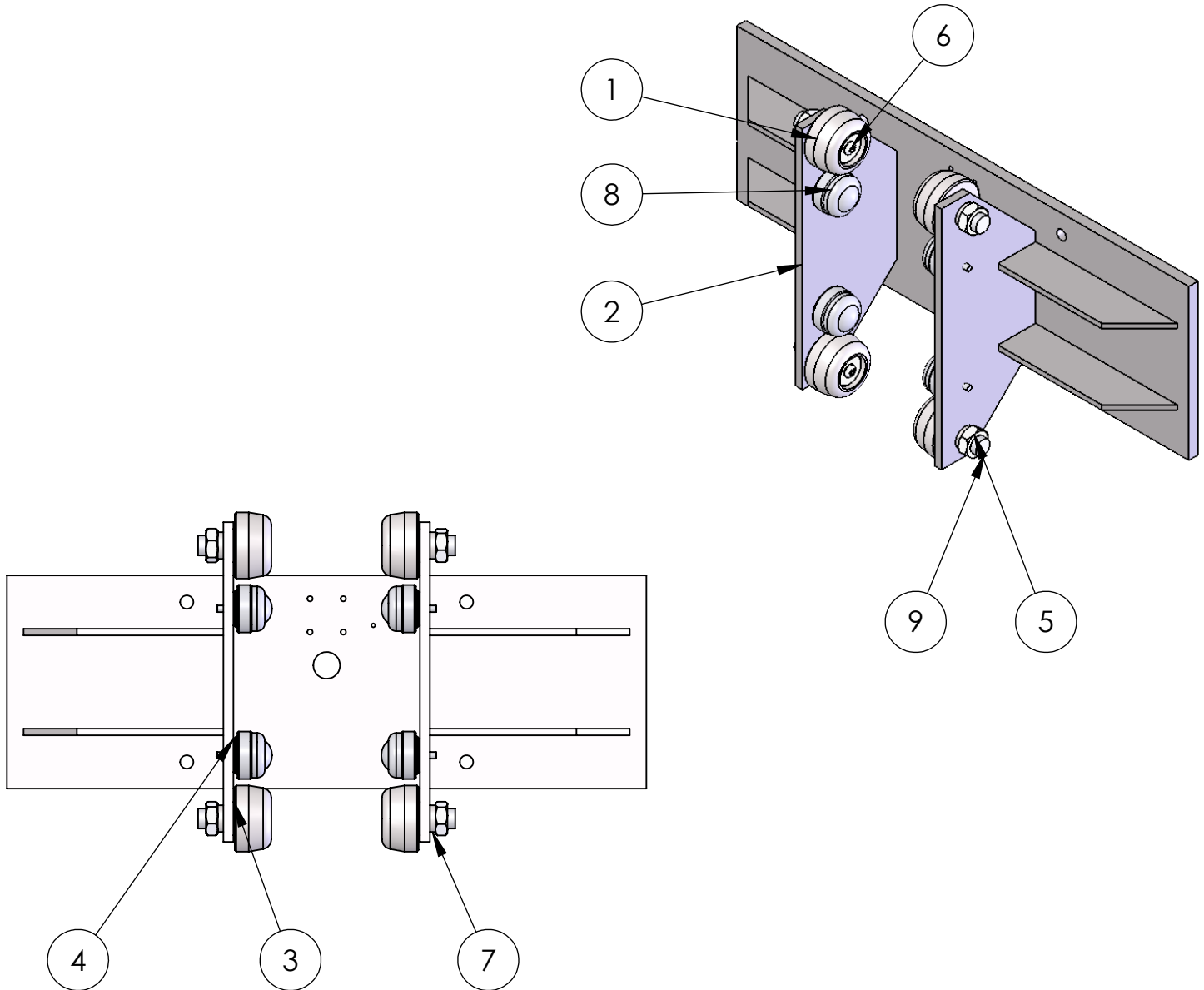

ITEM NO.	PART NUMBER	DESCRIPTION	QTY.
1	F64056A3	GUIDE RLR-BRG ASSY	4
2	F64335A6	BACK PL WLDMT	1
3	Z10008A0	BUSH-MACH 6H 3/4x18Gax1-1/4 OD	4
4	Z10042A8	WASHER-5/16 FNDR X 1-1/4 OD	8
5	Z10461A0	NUT-HEX JAM 3/4-16	4
6	Z10539A9	S-BHSC 5/16-18x3/4	4
7	Z10594A0	WASHER-3/4 LOCK MD	4
8	Z30700A8	BALL TRANSFER-STUD MNT 1/4-20	4
9	Z51355A9	GUIDE BOLT-3/4-16 1.00X1.14	4

# BATTERY POWERED ROTOLIFT

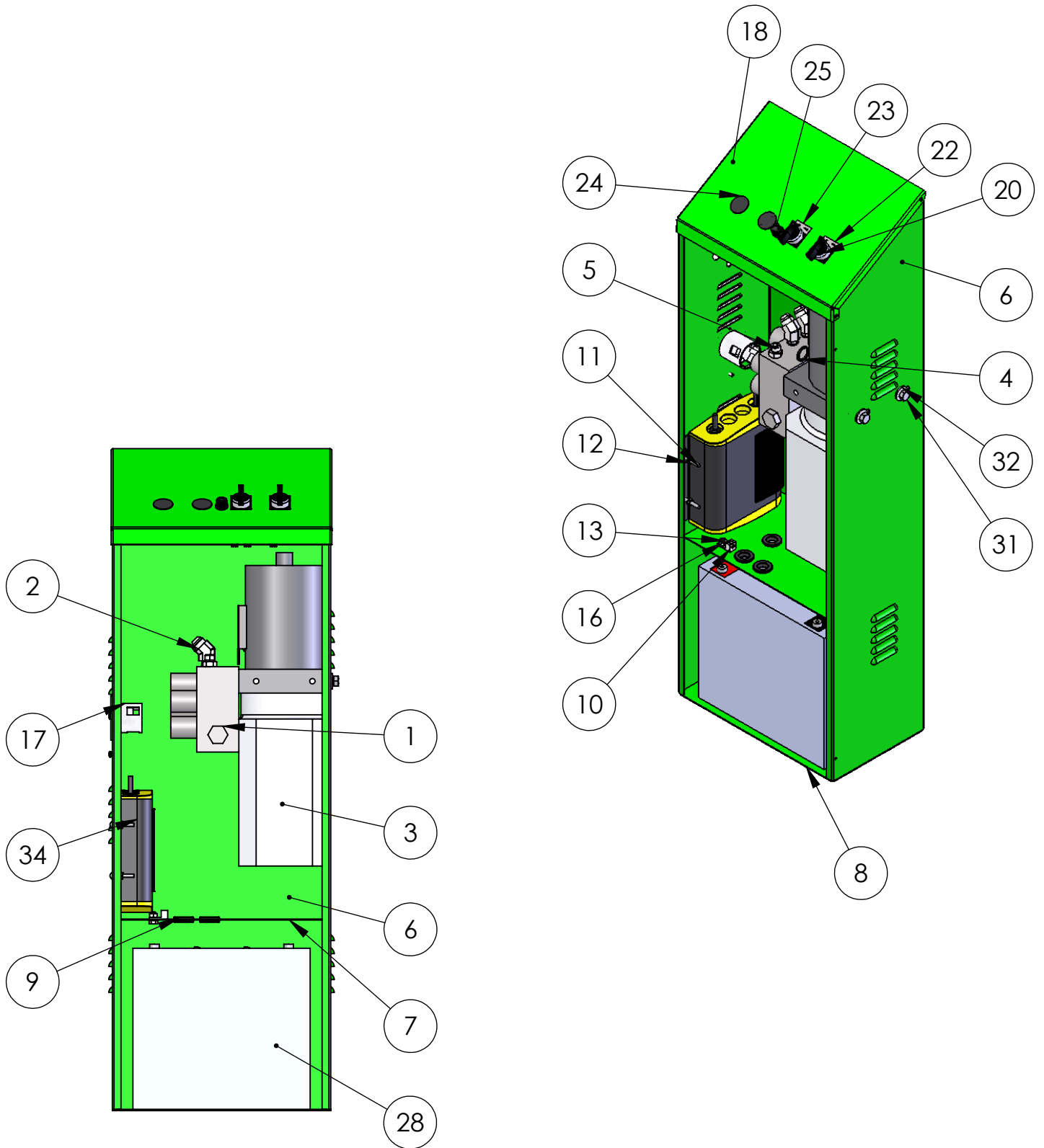

## BATTERY POWERED ROTOLIFT

ITEM NO.	PART NUMBER	DESCRIPTION	QTY.
1	Z20661A1	MANIFOLD-4SOL/3PORT 12V	1
2	Z20015A0	FTG 45 6802-4-6	2
3	Z20658A4	PP-BASE	1
4	Z20107A9	O'RING-ARP116	1
5	Z20597A5	FTG STR 6400-4-6-O	1
6	F58826A9	ENCL-CTRL BOX WLDMT (KANBAN)	1
7	F58827A0	DVDR-CTRL BOX WLDMT	1
8	F58828A1	BTM-CTRL BOX WLDMT	1
9	Z00116A0	GROMMET-.625ID SBR	3
10	Z10708A3	LUG-SET SCREW 1/4	1
11	Z10177A5	S-RHM #10-24X1-1/4	4
12	Z10391A5	NUT-HEX KEPS #10-24	4
13	Z10109A8	S-HHC 1/4-20X1/2	1
14	Z10385A3	S-PTHHC #8x3/8 LG	2
15	Z10207A9	WASHER-1/4 LOCK INT TOOTH	1
16	Z10035A7	NUT-HEX KEPS 1/4-20	1
17	Z00120A4	PLUG-FLGD INLET 125V	1
18	F58824A7	TOP-CTRL BOX (KANBAN)	1
19	Z00463A9	BASE-ADH MNT 1 x 1	1
20	Z00523A7	SWITCH-3 POS MOM SPR RTN	2
21	Z00524A6	CONTACT BLOCK N/O	1
22	Z00526A4	LEGEND-22MM "UP/DOWN"	1
23	Z00527A3	LEGEND-22MM "LEFT-RIGHT"	1
24	Z00529A1	PLUG-22MM HOLE	2
25	Z00530A0	FUSE HOLDER PANEL MNT	1
26	Z00542A8	CONTACT BLOCK 2 N/O	3
27	Z00543A7	FUSE-AGC 25 AMP	1
28	Z00172A5	BATTERY-12V 80AH SEALED LEAD	1
29	Z10036A6	NUT-HEX KEPS 5/16-18	2
30	Z10122A1	S-HHC 5/16-18X3/4	2
31	Z10132A9	S-HHC 3/8-16X1	2
32	Z10201A5	WASHER-5/16 FLAT USS	2
33	Z41156A5	LABEL-VALLEYCRAFT PAPER	1
34	Z00358A9	CHRGR-BATTERY 12V-6A 120VAC	1



## BATTERY POWERED ROTOLIFT

ITEM NO.	PART NUMBER	DESCRIPTION	QTY.
1	F69032A2	BACK SECT WLDMT/ROTO-LIFT	1
2	F52650A9	SPROCKET-LARGE	1
3	F52649A3	GUARD-CHAIN BTM/ROTO (KANBAN)	1
4	F62629A6	FRT SECT WLDMT/ROTO	1
5	Z20656A6	MOTOR-HYD/SAE	1
6	F52648A4	GUARD-CHAIN TOP/ROTO (KANBAN)	1
7	Z10393A3	NUT-LOCK 1/2-13	1
8	Z10148A1	S-HHC 1/2-13X1-1/2 GR5	6
9	Z10026A8	NUT-HEX JAM 3/8-16ZP	4
10	F30214A4	CHAIN-RS 50/46"	1
11	Z10627A7	ZERK-GREASE .188 DRIVE	2
12	Z30420A8	BRG-TAPER ROLL 1"BOR	1
13	F52527A0	NUT-LOCK 1-14/DT (KANBAN)	1
14	Z10090A9	S-SHS 5/16-18X3/8	2
15	Z10166A8	S-HHTC #10-24X1/2	9
16	Z10132A9	S-HHC 3/8-16X1	6
17	F52651A8	MOTOR MNT/ROTO	1
18	Z30400A2	SPROCKET-SM W/SHS	1
19	F62980A9	RATCHET ASSY-2.0X53.00 7000	2
20	Z10201A5	WASHER-5/16 FLAT USS	4
21	Z10020A4	NUT-HEX FULL 1/2-13	2
22	Z10214A0	WASHER-3/8 LOCK MD	2
23	Z10122A1	S-HHC 5/16-18X3/4	2
24	Z10013A3	WASHER-1 ID X 2-7/16 X 5/64	1

# HYDRAULIC POWER UNIT

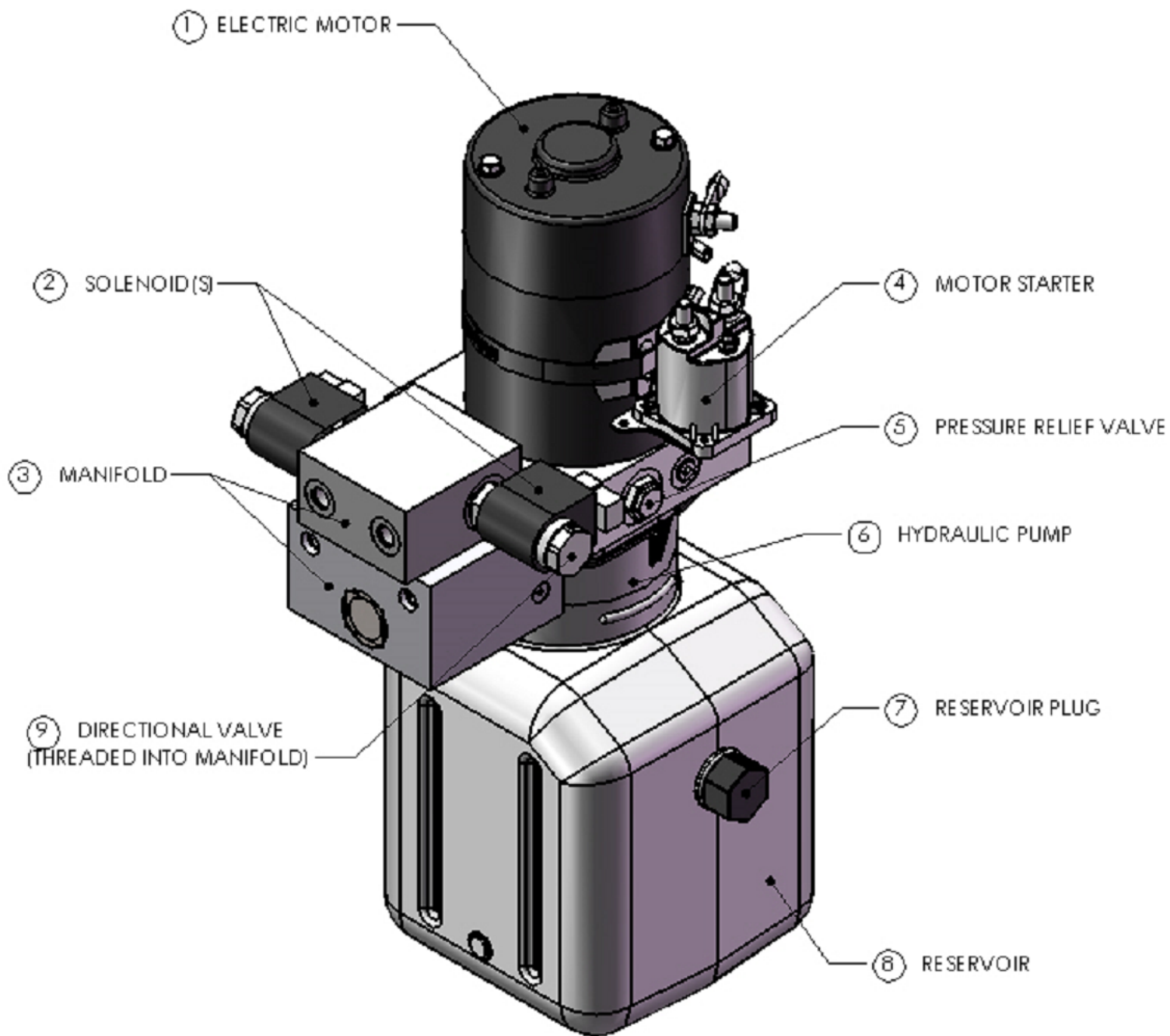

HYDRAULIC POWER UNIT SHOWN FOR REFERENCE ONLY; YOUR ACTUAL UNIT MAY VARY. FOR QUESTIONS, PLEASE CONTACT VALLEY CRAFT CUSTOMER SERVICE AT 1-800-328-1480 OR ON THE WEB AT [CUSTOMER@VALLEYCRAFT.COM](mailto:CUSTOMER@VALLEYCRAFT.COM)

# BATTERY POWERED ROTOLIFT

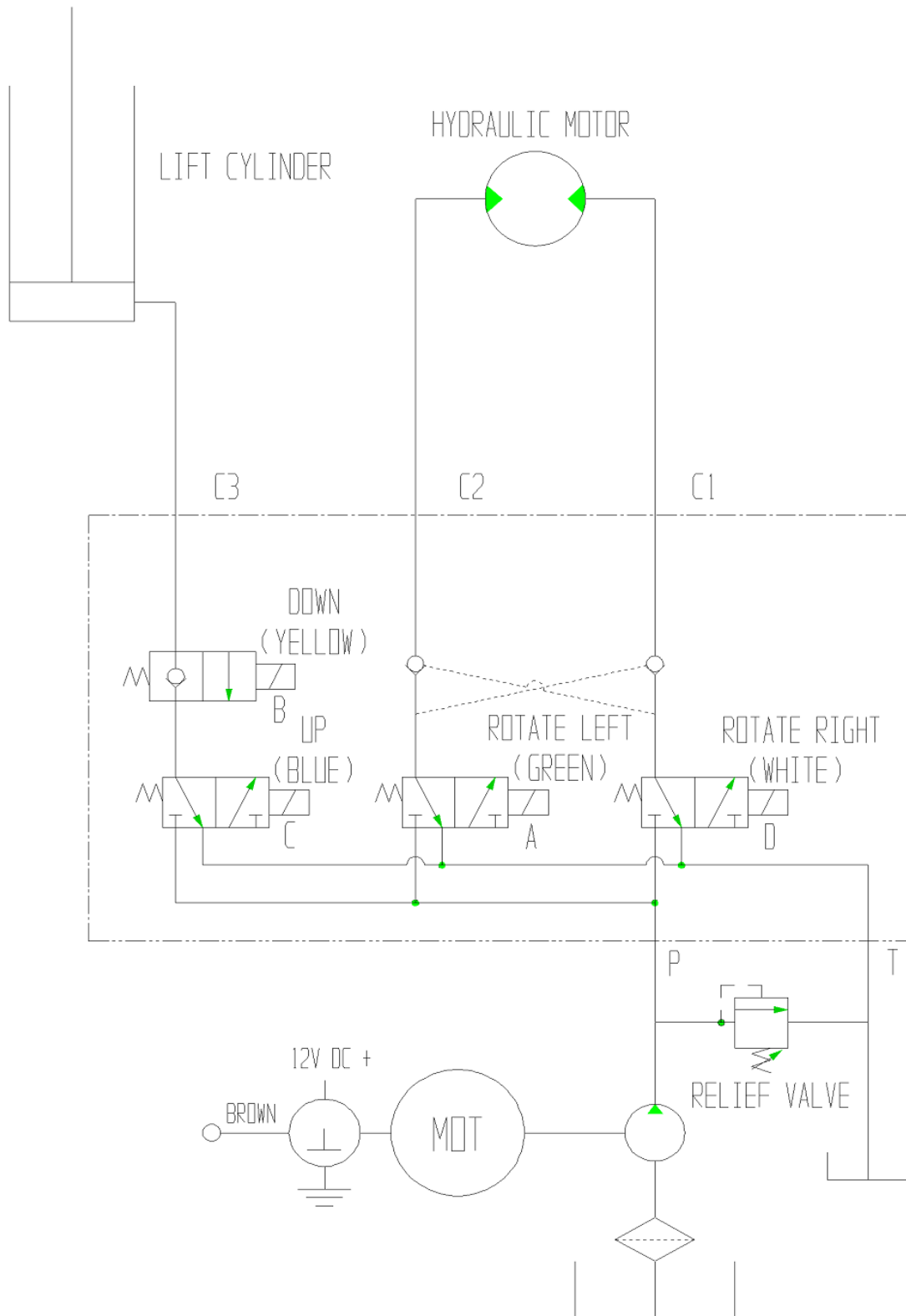

HYDRAULIC SCHEMATIC

# BATTERY POWERED ROTOLIFT

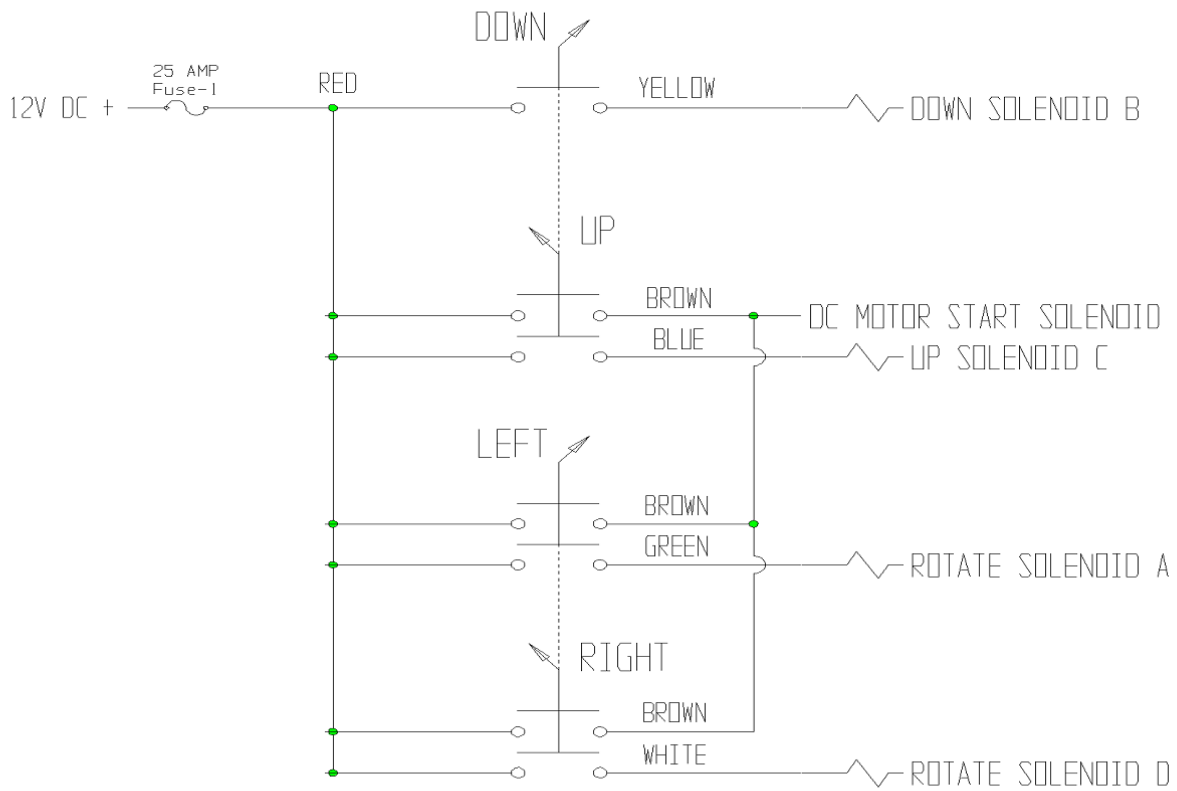

## ELECTRICAL WIRING

## Warranty and Limitation of Liability

Valley Craft products are warranted for a period of one (1) year from date of shipment from Valley Craft's plant to be free from defects in material and workmanship under correct use, normal operation and proper application. However, parts of other than Valley Craft manufacture are subject ONLY to the original manufacturer's warranty. Valley Craft's obligation under warranty shall be limited to repair or exchange, at Valley Craft's option, FOB origin factory, of any Valley Craft product or part which proves to be defective as provided herein. Valley Craft reserves the right to either inspect the product at Buyer's location, or require it to be returned to the factory for inspection. The warranty contained herein does not extend to goods damaged, or subject to accident, abuse or misuse after shipment from Valley Craft's factory, nor to goods altered or repaired by anyone other than an authorized Valley Craft representative.

Buyer or user shall not alter, modify or use a Valley Craft product for anything other than its intended function. Valley Craft shall not in any way be responsible for the consequences of any such alteration, modification or misuse.

VALLEY CRAFT MAKES NO EXPRESS WARRANTIES OTHER THAN THOSE WHICH ARE SPECIFICALLY DESCRIBED HEREIN. Any description of the goods sold hereunder, including any references to Buyer's specifications and any descriptions in catalogs, circulars and other written material published by Valley Craft, is for the sole purpose of identifying such goods and shall not create an express warranty that the goods shall conform to such descriptions.

THIS WARRANTY IS EXPRESSLY IN LIEU OF ALL OTHER WARRANTIES, EXPRESS OR IMPLIED. THERE ARE NO IMPLIED WARRANTIES OF MERCHANTABILITY OR FITNESS FOR A PARTICULAR PURPOSE. THIS WARRANTY STATES VALLEY CRAFT'S ENTIRE AND EXCLUSIVE LIABILITY AND BUYER'S EXCLUSIVE REMEDY FOR ANY CLAIM OR DAMAGES IN CONNECTION WITH VALLEY CRAFT PRODUCTS, THEIR DESIGN, SUITABILITY FOR USE, INSTALLATION OR OPERATION OR FOR ANY CLAIMED DEFECTS. VALLEY CRAFT WILL IN NO EVENT BE LIABLE FOR INCIDENTAL OR CONSEQUENTIAL DAMAGES WHATSOEVER, NOR FOR ANY SUM IN EXCESS OF THE PRICE RECEIVED FOR THE GOODS FOR WHICH LIABILITY IS CLAIMED.

## Technical Assistance/Warranty Procedure

### What's Covered:

Parts and Labor to correct manufacturer's defect within one year of purchase.

Freight Cost

### What's Not:

Normal wear items (seal kits, bearings, tires, etc.)

### What Voids the Warranty:

Dirt/Grime that directly causes malfunction of product

Abuse (i.e. Overloading, damaged, not properly maintained, etc.)

Product altered by customer

\*See "Items not Under Warranty" below for items that have the warranty voided.

### Items Under Warranty (less than one year old):

Warranty replacement parts are provided only when the problem can be identified with near certainty. If not, the customer will return item to Valley Craft, freight collect, for troubleshooting and/or repair. When repaired, product will be returned to customer, freight prepaid. Otherwise, customer may call local authorized service technician for assistance. . Under this arrangement, replacement parts will be sent at no charge but labor costs will NOT be covered.

### Items NOT Under Warranty (greater than one year old or "having warranty voided):

Customer will return item to valley Craft, freight prepaid, for troubleshooting and/or repair. Valley Craft will call customer with \$\$ estimate of parts and labor for approval before repairing. Product will be returned to customer, freight collect.

Or

Customer may call local authorized service technician for repairs at their own expense.



Valley Craft is a modern metals fabricating manufacturer specializing in material handling, storage and specialized solutions designed with safety and usability in mind, and the simplification of even the heaviest of workloads. Since developing the first hand truck with a brake in 1952, Valley Craft has been a true pioneer in safety-conscious material handling and solution-driven products. Our commitment to continuous improvement in a Lean Manufacturing environment results in safe, functional, quality equipment at affordable prices.

---

**Valley Craft, Inc.**

2001 South Highway 61  
Lake City, Minnesota 55041 U.S.A.

---

Phone: (651) 345-3386

Toll Free: (800) 328-1480

Fax: (651) 345-3606

E-Mail: [customer@valleycraft.com](mailto:customer@valleycraft.com)

Web: [valleycraft.com](http://valleycraft.com) • [ovation-solutions.com](http://ovation-solutions.com)

---