

# Installation/Operation

## 0093500 Electric Tongue Jack



### APPLICATION

The Electric Tongue Jack is a 12-volt motor-driven screw jack for use on travel trailers and boat trailers.

### SPECIFICATIONS

Vertical Load - 3500 lbs. continuous over full stroke with 5000 lbs. instantaneous tongue breakaway capacity.

Travel-18"

Power Requirement -12 volt D.C.

Retracted Height - 26-1/2"

Removable Foot Pad - 5-1/4" Dia.

Approximate Shipping Weight - 22 lbs.

### INSTALLATION

**1.** Block the wheels and support the trailer "A" frame securely.

**2.** Remove the existing jack.

**NOTE: Save the original nuts, bolts, and washers for installing the Electric Tongue Jack.**

**3.** The Electric Tongue is internally grounded. Therefore, for good electrical contact, remove powdercoat where the "A" frame comes in contact with the Tongue Jack Mounting Plate.

**4.** Install the Electric Tongue Jack using original nuts and bolts.

**5.** The Electric Tongue Jack was designed to replace an existing crank down jack. The diameter of the outer tube of your chosen jack, will need to match the existing hole size, or you will need to modify the hole diameter to fit.

**6.** Align the motor head so that the motor housing is facing the front of the "A" frame.

**7.** Connect 7-pin trailer connector to vehicle's trailer plug, or, if hard wiring connect the black positive lead to the positive terminal of the battery. The Electric Tongue Jack is internally grounded, and needs no ground wire if "A" frame is properly grounded.

**WARNING: When using an extension wire, DO NOT use smaller than #10 gauge wire.**

### OPERATION

**1.** Block trailer wheels securely.

**2.** The Electric Tongue Jack is operated by means of the Toggle Switch located under the motor housing.

**3.** Extend the jack by holding the Toggle Switch in the Extend position.

**CAUTION: Release the Toggle Switch when the motor switches off to prevent damage to motor. Wait 15 seconds for the motor to reset before operating the jack again.**

**4.** Retract the jack by holding the Toggle Switch in the Retract position. As the jack approaches the fully retracted position it will slow down and then stall. The Toggle Switch should be released at the first indication of slowing down. The jack is now fully retracted.

**NOTE: If the motor should stall with the jack in the fully retracted position, and the Toggle Switch is not released, the motor will automatically switch off.**

### MANUAL OPERATION

**1.** Remove level gauge in the access hole, (located top center of the housing cover)

**2.** Insert the crank handle in the access hole, over the drive spindle tang. Rotate the crank handle clockwise to retract and counter clockwise extend.

**3.** When complete, remove crank handle and replace level gauge and reassemble the fuse connection.

### LUBRICATION

The jack is lubricated before leaving the factory. Under normal conditions, lubrication will be needed after one year.

**WARNING: The weight of the Trailer tongue should be supported by blocks or the Ball Hitch of the tow vehicle before proceeding.**

**1.** The Foot should be fully extended.

**2.** Using the Toggle Switch, extend the jack until the Foot Pad is 2" from the ground.

**3.** Loosen the four #8 Phillips Head Screws and remove the Gear Housing Cover.

**4.** If required, repack the exposed gears with a common Lithium Base Machine Grease.

**5.** Reassemble Gear Housing Cover.

**6.** Using a 1/4" Allen Wrench, remove the four 5/16" Socket Head Screws holding the Motor Head to the Outer Tube.

**7.** Lift the Motor Head and Screw Assembly away from the Outer Tube.

**8.** Clean and regrease the Jack Screw and Nut with a common Lithium Base Machine Grease.

**9.** Reassemble Motor Head and Screw Assembly to Outer Tube. Replace the Fuse.

### Motor Exploded View

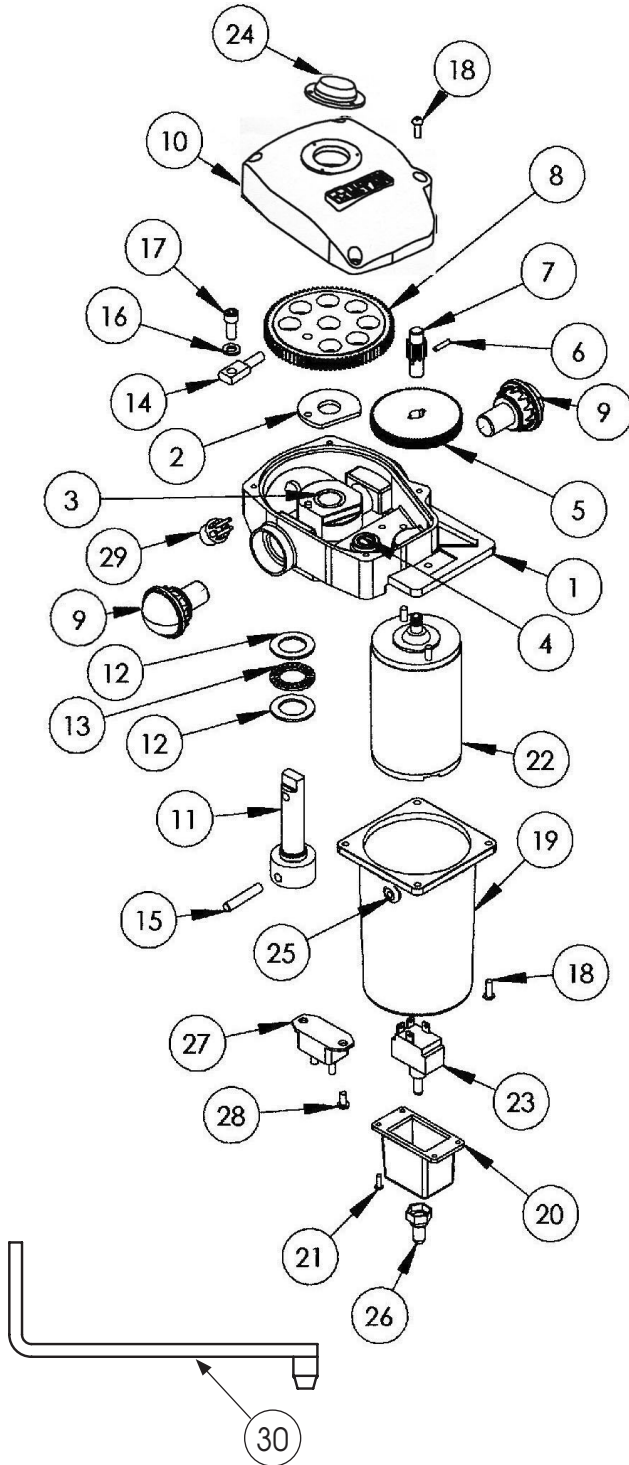

### Bill of Materials

ITEM	PART NO.	QTY.	DESCRIPTION
1	-	1	Main Housing
2	-	1	Thrust Washer
3	-	1	Bushing
4	-	1	Bushing
5	-	1	Spur Gear
6	-	1	Pin
7	-	1	Pinion Gear
8	-	1	Main Gear
9	-	2	Light
10	-	1	Housing Cover
11	-	1	Collar
12	-	2	Hard. Washer
13	-	1	Thrust Bearing
14	-	1	Headed Pin
15	-	1	Pin
16	-	1	1/4 Lock Washer
17	-	1	1/4 Cap Bolt
18	-	8	#8-32 Screw
19	-	1	Motor Housing
20	-	1	Switch Housing
21	-	4	#5-40 Screw
22	-	1	Motor
23	-	1	Motor Switch
24	-	1	Level Gauge
25	-	1	Grommet
26	-	1	Boot Snap Seal
27	-	1	Circuit Breaker
28	-	2	#8 Screw
29	-	1	Light Switch

Note: Not Shown

TC2007P	1	7-Pin RV Trailer Connector
---------	---	----------------------------

### Replacement Parts

ITEM	PART NO.	QTY.	DESCRIPTION
9	3013226	1	Light
10	3013227	1	Housing Cover
24	3013240	1	Level Gauge
29	3013246	1	Light Switch
19,22,25	3013319	1	Motor Assembly
23,26	3013320	1	Switch Assembly
30	3013247	1	Manual Crank

**Lower Stem Assembly  
Exploded View**

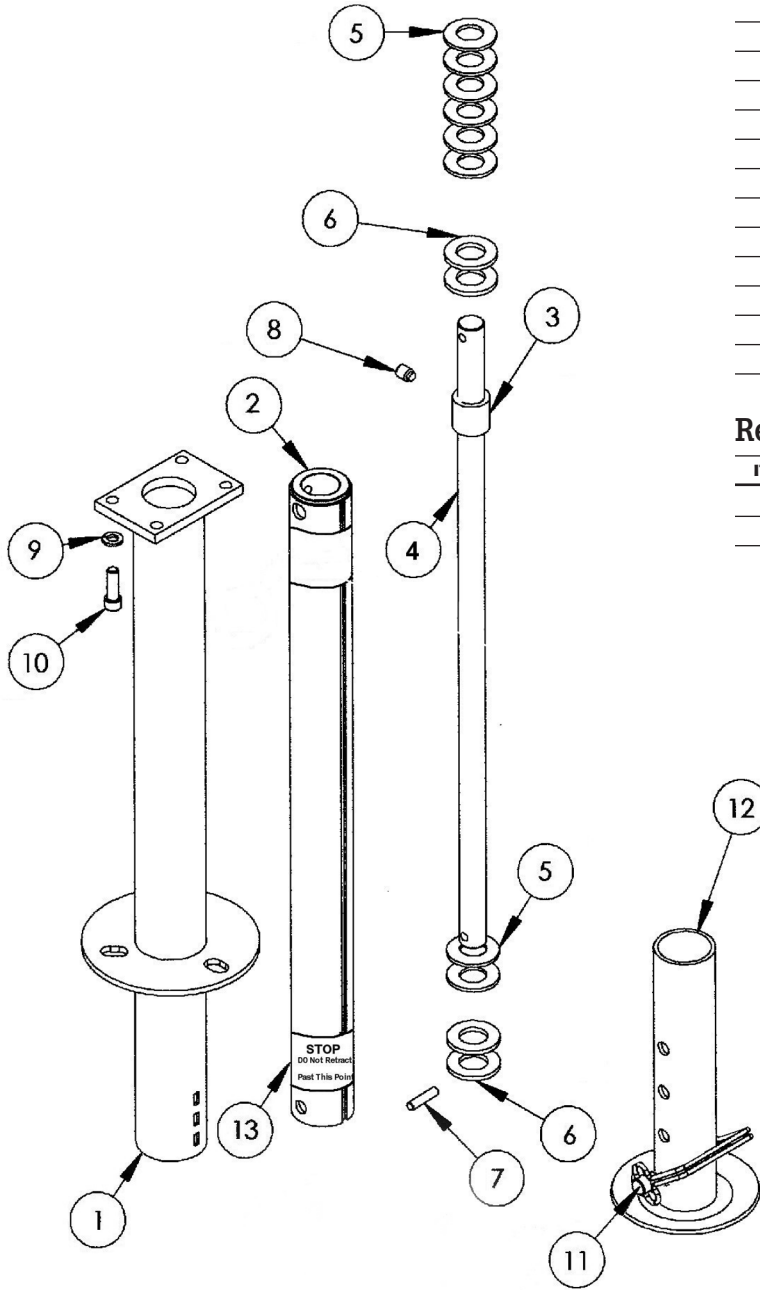

**Bill of Materials**

ITEM	PART NO.	QTY.	DESCRIPTION
1	-	1	2.25" Outer Tube
2	-	1	2" Inner Tube
3	-	1	Bronze Nut
4	-	1	Jackscrew
5	-	8	Bellville Washer
6	-	4	Flat Washer
7	-	1	Pin
8	-	1	3/8 Set Screw
9	-	4	5/16 Lock Washer
10	-	4	5/16 Cap Screw
11	-	1	3/8 Snapper Pin
12	-	1	Footpad
13	-	1	Label, STOP, Do Not Retract...

**Replacement Parts**

ITEM	PART NO.	QTY.	DESCRIPTION
11	3013260	1	3/8 Snapper Pin
12	3013261	1	Footpad



### Wiring Diagram

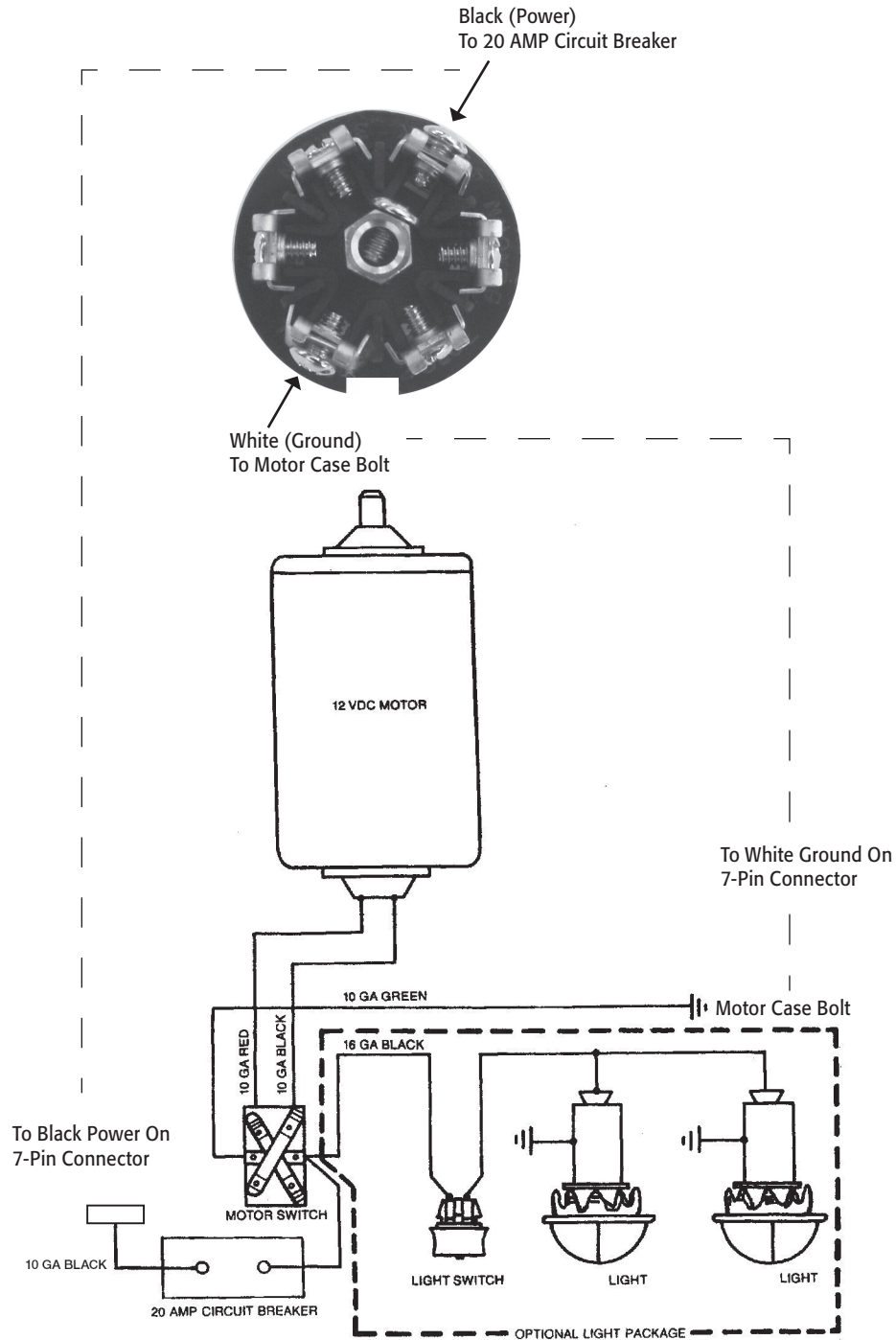

### WARRANTY

Buyers Products Co. warrants all truck/trailer hardware manufactured or distributed by it, to be free from defects in material and workmanship for a period of one year from date of shipment. Parts must be properly installed and used under normal conditions. Any product which has been altered, including modification, misuse, accident or lack of maintenance will not be considered under warranty. Normal wear is excluded. The sole responsibility of Buyers Products Co. under this warranty is limited to repairing or replacing any part or parts which are returned, prepaid, and are found to be defective by Buyers Products Co. Authorization from Buyers Products Co. must be obtained before returning any part. No charges for transportation or labor performed on Buyers' products will be allowed under this warranty.