



20 TON | 40 TON SHOP PRESS OPERATIONS MANUAL

SERIAL NUMBER: _____



ORIGINAL INSTRUCTIONS - SHOP PRESS

1 DECLARATION OF E.C. COMPLIANCE

3 GENERAL

- Company Profile
- Machine Identification
- Warranty
- Declaration of E.C. Compliance
- Operator and Supervisor Information
- Signal Word Definition
- Signal Word Panel
- Operational Precautions
- Machine Operations

6 HYDRAULIC POWER SOURCES

- Powering with an Edwards Ironworker
- Powering with an Edwards Porta-Power

8 OPERATIONS DIAGRAM

9 OPERATIONS

- Adjusting the Table
- Loading/Supporting/Securing Material
- Adjusting the Hydraulic Ram
- Safe Operation
- Press Operation

OPTIONAL TOOLING

- 11 Brake
- 12 Press Brake Tooling Set
- 14 Rod Shear/Multi-Shear
- 15 Pipe Notcher

16 TROUBLESHOOTING

DECLARATIONS OF CONFORMITY

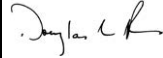
EU DECLARATION OF CONFORMITY WITH COUNCIL DIRECTIVE 2006/42/EC	
Date of Issue:	01/11/2013
Directive:	Machinery Safety Directive 2006/42/EC Electromagnetic Compatibility Directive 2004/108/EEC Low Voltage Directive 2006/95/ES
Conforming Machinery:	Model: Shop Press Type: Hydraulic Accessory Serial Number: Refer to Title Page
Manufacturer:	Edwards Manufacturing Company 1107 Sykes Street Albert Lea, MN 56007, USA
Person Authorized to compile the Technical File Established in the EU	Julian Smith and Melanie Smith – Directors Alpha Punch & Machinery Ltd Unit 7 Binder Industrial Park Eland Road Denaby, Doncaster DN12 4HA UK Tel: 011-441709866083 Fax: 011-441709866356
Harmonised Standards Referenced or Applied:	EN 13857:2008, EN ISO 13850:2008, EN 60204-1:2006+A1:2009/AC 2010, EN 12100:2010, EN 349:1993+A1:2008, EN 953:1997+A1:2009, EN 1037:1995+A1:2008, EN 614-1:2006+A1:2009, EN ISO 4413:2010, BS EN 13849-1:2006
Specifications with which Conformity is Declared:	Essential Health and Safety Requirements of Annex 1 of the Machinery Directive
We hereby certify that the machinery described above conforms with the essential health and safety requirements of Council Directive 2006/42/EC on the approximation of the laws of the Member States relating to the safety of machinery.	
Signed:	
Signatory:	Printed Name : Douglas L. Friend Title: Chief Operating Officer
Technical File Reference Number	SF11987A1.EMC

Notes Concerning Harmonized Standards Referenced or applied:	
EN ISO 13857:2008	Safety of machinery. Safety distances to prevent hazard zones being reached by upper and lower limbs.
EN ISO 13850:2007	Safety of machinery — Emergency stop — Principles for design
EN 60204-1:2006+A1:2009/AC 2010	Safety of machinery. Electrical equipment of machines. General requirements.
EN 349:1993+A1:2008	Safety of machinery. Minimum gaps to avoid crushing of parts of the human body.
EN 953:1997+A1:2009	Safety of machinery. Guards. General requirements for the design and construction of fixed and movable guards.
EN 1037:1995+A1:2008	Safety of machinery. Prevention of unexpected start-up
EN 12100:2010	Safety of Machinery – General Principles for design – Risk Assessment and risk reduction.
EN 614-1:2006+A1:2009	Safety of machinery — Ergonomic design principles — Part 1: Terminology and general principles.
EN ISO 4413:2010	Hydraulic fluid power - General rules and safety requirements for systems and their components
BS EN 13849-1:2006	Safety of machinery. Safety related parts of control systems. General principles for design

DECLARATION OF NOISE EMISSION Sound Pressure and Sound Levels per EN ISO 1102		
Date of Issue:	01/11/2013	
Machinery:	Model: Shop Press Type: Hydraulic Accessory Serial Number: Refer to Title Page	
	Operating	Idle
L _{plm} (Operator Position)	84 dB (A)	43 dB (A)
L _{plm} (Bystander Position)	81 dB (A)	41 dB (A)
Peak C-weighted instantaneous SPL in the Operator's position L _{pCpeak}	95 dB (C)	---
Sound power emitted where the equivalent continuous A-weighted SPL exceeds 80 dB (A).	8.4 Bel	---
The average difference between the extraneous noise level and the sound intensity level at each measuring point is:	L _{plm} Δ = 41 dB (A)	
Ambient Correction Factor K3A calculated according to EN ISO 11204 Appendix A.	4 dB (A)	
Measurements were made at a height of 1.5 m and 1 m from the Operator Position and all four sides of the equipment.		
The figures quoted are emission levels and are not necessarily safe working levels. While there is a correlation between the emission and exposure levels this cannot be used reliably to determine whether or not further precautions are required.		
Factors that influence the actual level of exposure of the workforce include characteristics of the work room, the other sources of noise, etc. such as the number of machines and other adjacent processes. Also, the permissible level of exposure can vary from country to country.		
This information, however, will enable the user of the machine to make a better evaluation of the hazard and risk.		
Edwards Manufacturing Company 1107 Sykes Street Albert Lea, MN 56007 USA		

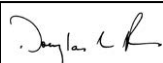
Declaration of Conformity with ANSI / ISO / NFPA / OSHA Standards relating to the Manufacture of Ironworking Machinery	
Date of Issue:	12/05/2013
Applicable Standards:	ANSI / ISO / NFPA / OSHA
Conforming Machinery:	Model: Shop Press Type: Hydraulic Accessory Serial Number: Refer to Title Page
Manufacturer:	Edwards Manufacturing Company 1107 Sykes Street Albert Lea, MN 56007, USA
Harmonised Standards Referenced or Applied:	ANSI B11.05, ANSI B11.0, ANSI B11.19, ANSI / ASSE Z244.1, ANSI Z535.2, ANSI Z535.3, ANSI Z535.4, ANSI Z535.5, ANSI / ISO 12100, ISO 13849-1, NFPA 79, OSHA1910.147, OSHA1910.212, OSHA1910.219
We hereby certify that the machinery described above conforms with the essential health and safety requirements of Council Directive 2006/42/EC on the approximation of the laws of the Member States relating to the safety of machinery.	
Signed:	
Signatory:	Printed Name : Douglas L. Friend Title: Chief Operating Officer
Technical File Reference Number	SF11987A1.EMC

Notes Concerning Harmonized Standards Referenced or applied:	
ANSI B11.05 1988 (R2008)	Ironworkers - Safety Requirements for Construction, Care and Use
ANSI B11.0 2010	Safety of Machinery - General requirements and Risk Assessment
ANSI B11.19	Performance Criteria for Safeguarding
ANSI / ASSE Z244.1 2003 (R2008)	Control of Hazardous Energy - Lockout / Tagout and Alternate Methods
ANSI Z535.2 2011	Environmental and Facility Safety Signs
ANSI Z535.3 2011	Criteria for Safety Symbols
ANSI Z535.4 2011	Product Safety Signs and Labels
ANSI Z535.6 2011	Product Safety Information in Product Manuals, Instructions, and Other Collateral Materials
ANSI / ISO 12100	Safety of Machinery - General Principles for design - Risk Assessment and risk reduction.
ISO 13849-1	Safety of machinery. Safety related parts of control systems. General principles for design.
NFPA 79 2012	Electrical Standards for Industrial Machinery
OSHA1910.147 1989	The Control of Hazardous Energy (Lockout / Tagout)
OSHA1910.212 1971	General Requirements for all Machines
OSHA1910.219 1971	Mechanical Power Transmission Apparatus

COMPANY PROFILE

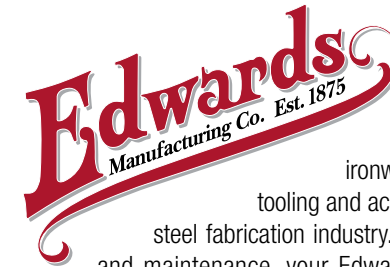

Edwards Manufacturing Company manufactures a full line of high quality, low maintenance hydraulic ironworking machines, associated tooling and accessories that are used in the steel fabrication industry. With proper operation, care, and maintenance, your Edwards Ironworker or Hydraulic Accessory Tool will provide years of safe, trouble-free service. Please take time to study this Operator's Manual carefully to fully understand Ironworker and Hydraulic Accessory Tool safety procedures, set-up, operation, care, maintenance, troubleshooting and warranty coverage prior to putting the machine into production. Any questions not answered within this manual can be directed to your local Edwards Ironworker dealer or factory representative.

Contact the factory:

EDWARDS MANUFACTURING COMPANY
1107 Sykes Street
Albert Lea, MN 56007
507 373 8206 PHONE
507 373 9433 FAX
www.edwardsironworkers.com

General Questions:
sales@edwardsmfg.us

Service Questions:
service@edwardsmfg.us

Contact your dealer:

WARRANTY

Edwards Manufacturing Company will, within one (1) year of date of original purchase (proof of purchase required), replace F.O.B. the factory, any goods, excluding punches, dies and shear blades, which are defective in materials or workmanship provided that the buyer return the defective goods, freight pre-paid, to the seller, which shall be the buyer's sole and exclusive remedy for the defective goods. Hydraulic components are subject to their manufacturer's warranty.

Edwards Manufacturing Company will, within thirty (30) days of date of original purchase (proof of purchase required), replace F.O.B. the factory, any punches, dies and/or shear blades, which are defective in materials or workmanship.

This warranty does not apply to machines and/or components which have been altered, changed or modified in any way, or subjected to abusive and abnormal use, inadequate maintenance and lubrication, or subjected to use beyond seller recommended capacities and specifications. Edwards Manufacturing Company shall not be liable for labor costs expended on such goods or consequential damages. Edwards Manufacturing Company shall not be liable to the purchaser or any other person for loss, down-time, or damage directly or indirectly arising from the use of the goods or from any other cause. No officer, employee, or agent of Edwards Manufacturing Company is authorized to make any oral representations or warranty of fitness or to waive any of the foregoing terms and none shall be binding on Edwards Manufacturing Company.

MACHINE IDENTIFICATION

Your Edwards Shop Press has been serialized for quality control, product traceability and warranty enforcement. Please refer to the aluminum identification tag with engraved serial number, electrical and power specifications when ordering parts or filing a warranty claim.

OPERATOR AND SUPERVISOR INFORMATION

This is one of four manuals supplied with your machine.

- Installation Manual
- Safety Instructions Manual
- Operations Manual
- Maintenance Manual

READ ALL MANUALS BEFORE OPERATING MACHINERY. Operating machinery before reading and understanding the contents of all four manuals greatly increases the risk of injury.

Each of the four machine manuals describe 'best practices' in handling, installing, operating and maintaining your machine. The contents of each manual is subject to change without notice due to improvements in the machinery or changes in National or International standards.

All rights reserved. Reproduction of this manual in any form, in whole or in part, is not permitted without the written consent of Edwards Manufacturing Company.

Keep all manuals close to the machine to allow for easy reference when necessary.

Provide operators with sufficient training and education in the basic functions of the machine prior to machine operation.

Do not allow for operation of the machine by unqualified personnel. Edwards Manufacturing Company is not liable for accidents arising from unskilled, untrained operation.

Do not modify or change the machine without written authorization from Edwards Manufacturing Company. Unauthorized modification to a machine may result in serious operator injury, machine damage and will void your machine warranty.

Never leave a powered machine unattended. Turn machinery **OFF** before walking away.

This machine is manufactured for use by able bodied and able minded operators only. Never operate machinery when tired or under the influence of drugs or alcohol.

Do not resell, relocate or export to a destination other than to the original point of sale. Edwards has designed this machine to meet the standards of the original receiving country and is not liable for meeting any governing body or performance standards beyond those of the original receiving country.

SIGNAL WORD DEFINITION

 **DANGER**

Indicates a hazardous situation that, if not avoided, will result in death or serious injury.

 **WARNING**

Indicates a hazardous situation that, if not avoided, could result in death or serious injury.

 **CAUTION**

Indicates a hazardous situation that, if not avoided, could result in mild or moderate injury.

NOTICE

Indicates information considered important, but not hazard related.

SIGNAL WORD PANEL ON MACHINE

 **DANGER**

Critical machine safety information is identified on signal word labels. Labels are attached adjacent to the potentially hazardous locations of the machine. Reference the Safety Instruction Manual for additional information regarding the potentially hazardous condition identified on the label.

Review ALL labels on the machinery, reference the operational precautions and safe operations sections within this manual before any operation activity is initiated.

Failure to read and understand the signal word labels affixed to the machinery may result in operator death or injury.

OPERATIONAL PRECAUTIONS

 **DANGER**

Reasonable, common sense safety precautions should be observed when operating the Ironworker or Hydraulic Accessory Tool. The following precautions are described in order of their hazard.

Electrical Hazard

Dangerous high voltages are present inside the electrical enclosure of this product. Only qualified, authorized, maintenance or service personnel should gain access to the electrical panel.

Lockout Power

Danger, circuits are live. Lockout / tagout upstream power source before any maintenance activity is performed.

Shear / Crush Hazard

Moving parts can cut and crush. Keep hands clear when servicing and maintaining the Ironworker.

Hydraulic Fluid Hazard

Hydraulic hoses are under pressure. Pressurized fluid can pierce skin and cause severe injury. To avoid physical hazard, always wear personal protective equipment when servicing / maintaining the Ironworker.

Do Not Operate With Guard Removed

Physical barriers and guards have been designed and installed to protect maintenance personnel from moving parts that can pinch, cut and crush. If it is necessary to remove guarding when servicing the Bender, immediately replace guards after service and prior to power being restored to the machinery.

Refer to Manuals

For safe installation, operation and maintenance of the machine, read:

- Installation Manual
- Safety Instructions Manual
- Operations Manual
- Maintenance Manual

Wear Personal Protective Equipment

To avoid physical hazard wear protective eyewear, clothing, gloves, footwear, head-gear and hearing protection.

MACHINE OPERATIONS

 **DANGER**

Edwards Hydraulic 20 and 40 Ton Press machinery are 'do-all' tools capable of many functions. This manual outlines the basic functions associated with typical press operations and is neither intended to create a comprehensive list of, nor describe every operation possible with a press tool. **Press operations are dangerous and require extreme care and caution in the preparation of the material being worked, the press set-up and the pressing operation.** Please refer to the following setup, safe operation and press operation sections for an understanding of the potential hazards present in any pressing operation.

Edwards 20 and 40 Ton Presses feature robust design and construction and are designed for years of heavy duty service when powered by an Edwards Ironworker or Porta Power portable hydraulic unit. Both Press styles perform similar functions and require the same amount of care in the safe installation, operation and maintenance. Please refer to all Edwards power source manuals as well as the Safety, Installation, Operation and Maintenance Manuals of the 20 Ton / 40 Ton Press prior to operation of the machinery.

The Press is constructed of four basic assemblies. The stationary rail assembly holds the stationary head assembly. The press bed assembly moves up and down the stationary rails and the hydraulic cylinder assembly rolls from side to side on the stationary head. Both the rolling cylinder assembly and moving press bed assembly are locked into place prior to any press operation.

The following pages detail the proper operations procedures for setting up and safely operating the Edwards 20 Ton or 40 Ton Shop Press.

HYDRAULIC POWER SOURCES



Hydraulic Accessory Tool Power/Controls



Ironworker Hydraulic Accessory Package

WARNING

Your Edwards 20 Ton or 40 Ton Shop Press is factory assembled and tested for optimum performance when powered by Edwards Manufacturing Company rated hydraulic power supply.

The Shop Press is powered by either an Edwards Ironworker factory installed Hydraulic Accessory Control Package or an Edwards Porta-Power, 5hp, 3000psi, portable power unit.

ALTERNATE POWER SOURCES ARE NOT RECOMMENDED AND MAY COMPROMISE MACHINE OPERATION, MACHINE HYDRAULIC WARRANTY AND OPERATOR SAFETY.

Follow electrical connection installation instructions for power supply as set forth within the Installation Manual of the Edwards Ironworker.

Powering with an Edwards Ironworker

Power selection controls are located adjacent to the starter box on the feed side of the machine. Hydraulic quick connections and accessory controls are located on the drop-off side or end cap of the machine.

With the Ironworker power off, install Shop Press hoses, power and control:

- Install the Shop Press male and female accessory hydraulic hoses to the ironworker male and female quick connect hydraulic fittings. Both fittings have a detent ball setting that must be aligned to couple and uncouple hoses.
- Remove the safety cap at the push button port. Attach the Shop Press control OUT / IN, male Mil Spec control cable to the female Mil Spec accessory control port at your Ironworkers Hydraulic Accessory package.

With all Ironworker and Press stations clear of hands, tools, tooling, material or debris, power up the Ironworker by depressing the green button on the starter box.

With the power on, your Ironworker machine will return to a neutral position.

Turn the 3-position switch on the front of the machine case to the Accessory position. This operation disables the Ironworker and switches control to the accessory hand control.

With all Shop Press work stations clear of hands, tools, tooling, material or debris, test the Shop Press operation by depressing the OUT control button. Once depressed, the hydraulic cylinder of the Shop Press will extend to operate the accessory. Releasing pressure on the OUT control button will stop the machine mid-operation. Return the tool to its starting position by depressing the IN button.

When Disconnecting your Shop Press, simply reverse procedure. **Replace the safety cap at the push button port to restore power to your Ironworker.**



Powering with an Edwards Porta-Power

Your Edwards Porta-Power 5hp / 3000psi / Portable Power Unit will power all your Edwards Hydraulic Accessories.

Follow electrical connection installation instructions as set forth within these sections of the Porta-Power Installation Manual:

With the Edwards Porta-Power off, install accessory hoses, power and control:

- Install the male and female Shop Press hydraulic hoses to the Porta-Power male and female quick connect hydraulic fittings adjacent to the starterbox. Both fittings have a detent ball setting that must be aligned to couple and uncouple hoses.
- Remove the safety cap at the push button port. Attach the Shop Press OUT / IN, male Mil Spec control cable to the female Mil Spec accessory control port on the Porta-Power case.

With all Press stations clear of hands, tools, tooling, material or debris, power up the Porta Power by depressing the green button on the starter box.

Test the accessory operation by depressing the OUT control button. Once depressed, the hydraulic cylinder of the Shop Press will extend to operate the accessory. Releasing pressure on the OUT control button will stop the machine mid-operation. Return the Shop Press to its starting position by depressing the IN button.

If the machine fails to cycle, power down the Porta-Power by depressing the red button on the starterbox, consult the trouble shooting section of the Operations Manual.

Depress the red e-stop button on the hand control to kill power at the Porta Power. To reset power, twist the e-stop button and push start button at Porta Power.

When disconnecting your Press, simply reverse procedure. **Replace the safety cap at the push button port to restore power to your Porta Power.**

OPERATIONS DIAGRAM

40 Ton Shop Press Shown - 20 Ton similar

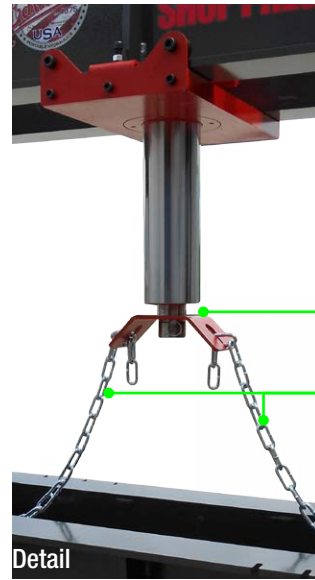

Detail

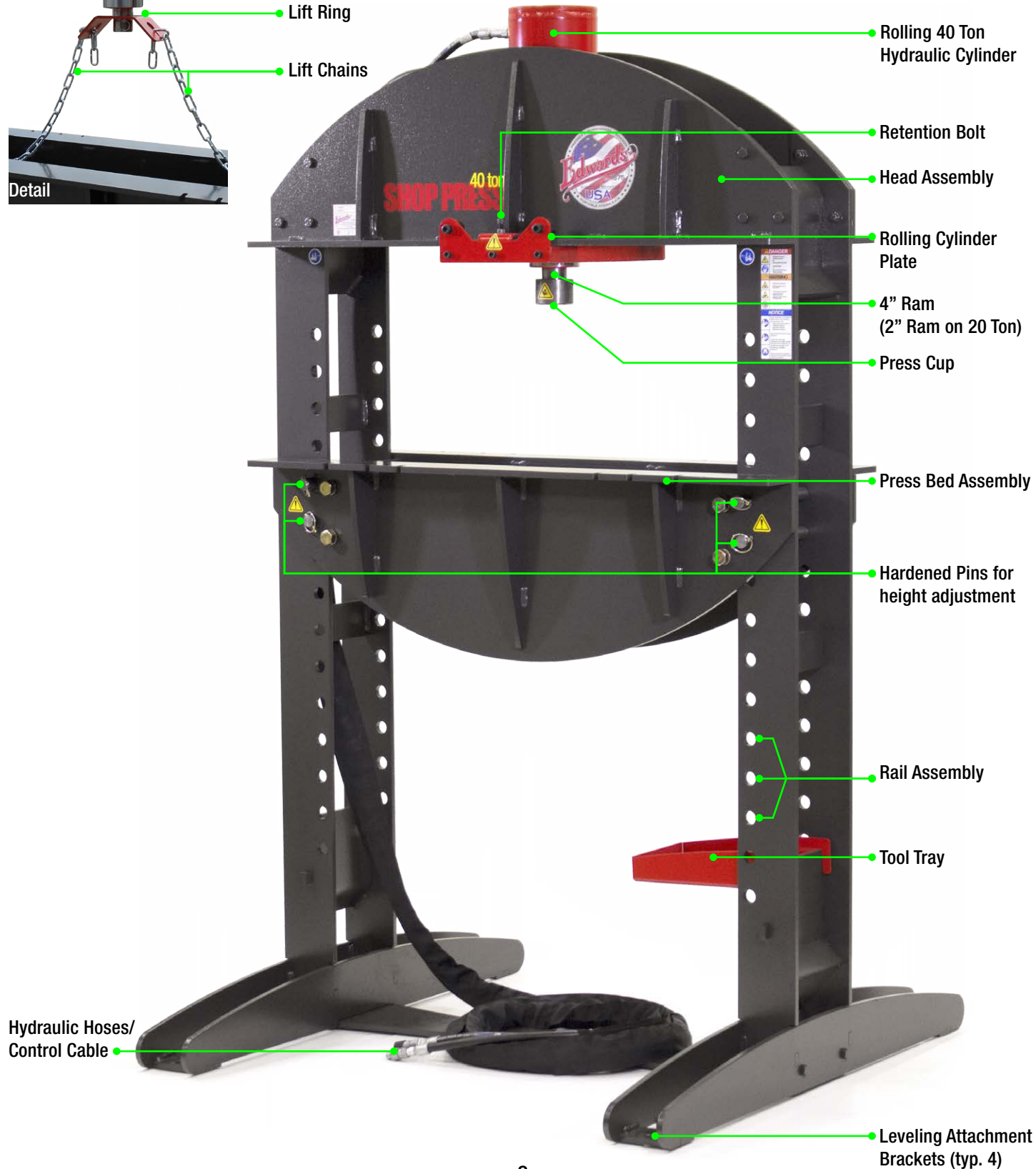

OPERATIONS

⚠️ WARNING

Adjusting the Table

The press bed height adjusts in relation to the stationary elevation of the cylinder ram. **Do not attempt to manually lift or lower the press bed.** Utilize lift ring and lift chains to incrementally lift or lower the press bed to the appropriate working height for the material being pressed. Install the lift ring by removing the press cup at the ram end. Install the lift ring on the ram, lift beyond the 3/8" bore through the ram and secure with 3/8" grade 8 linchpin through ram. Identify the horizontal keyholes at both ends of the press bed assembly.

To raise the table, extend the ram and lift ring completely. Link the chains provided over the lift ring and drape chains through the keyholes in the press bed assembly. Make sure the chain links are equally distributed either side of the ram to the press bed keyholes. Engage chain into keyholes. Once secure, carefully raise the ram so that any slack is drawn out of the chains. Once tension is put on the chains, carefully remove the lynch pins and hardened pins securing the press bed to the rail assembly. With the pins removed, carefully retract the cylinder to raise the press bed to the desired position. Insert hardened pins, re-install linchpins and remove lift chains and lift ring hardware to complete the press bed change.

To lower the table, retract the ram and lift ring to within 1/2" of complete retraction. Link the chains provided over the lift hooks and drape chains through the keyholes in the press bed assembly. Make sure the chain links are equally distributed either side of the ram to the press bed keyholes. Once secure, carefully raise the ram so that any slack is drawn out of the chains. Once tension is put on the chains, carefully remove the linchpins and hardened pins securing the press bed to the rail assembly. With the pins removed, carefully extend the cylinder to lower the press bed to the desired position. Insert hardened pins, re-install lynch pins, and remove lift chains and lift ring hardware to complete the press bed change.

Loading / Supporting / Securing Material

Examine the material to be worked. Understand irregularly shaped materials and be prepared to adequately and safely support them through the pressing cycle. Utilizing best practices, carefully load the material into the working cavity of the press and support the material on the press bed with pressing aids such as arbor plates (not included). Utilize clamps or other security devices to hold the workpiece when practical. Consider the security and stability of the workpiece in the press cycle. A secure workpiece allows for both hands to operate the machine.

Adjusting the hydraulic ram

The hydraulic ram is mounted to a rolling plate. The rolling feature allows for precision alignment for off-center pressing applications. Once aligned over the press site, carefully extend the ram to the press surface and fine-tune the ram alignment. Before starting the pressing operation, tighten the retention bolt at the rolling cylinder plate to secure the cylinder during the press operation.



- Center ram.
- Extend ram.
- Attach lift ring
- Insert pin into ram to hold lift ring in place.
- Attach lift chains to lift ring.
- Attach lift chains to press bed.



- Retract ram to tighten lift chains.
- Remove hardened pins.
- Retract ram to lift press head.



- Insert hardened pins at desired location.
- Replace cotter pins.
- Extend ram to relieve tension on chains.
- Remove chains and lifting hook.
- Install press cup.

OPERATIONS

DANGER

Safe Operation

Observe the following guidelines when performing Press operations.

- **Operator Safety / Safe Work Zone** Applying pressure to parts or assemblies can fail the part being worked, fail a part adjacent to the work or fail the pressing tool. Failed parts can become airborne projectiles with deadly force. Protect yourself with appropriate personal protective equipment when operating the press. Protect others by defining a safe work zone for press use and limiting access to the press operator.
- **Press Inspection** Press operations may generate concussive failure to mechanical parts. Although Edwards press machinery is fabricated with both bolted and welded construction, concussive failure is a possibility over time or with extreme use. Prior to any press operation, visually check all bolted and welded connections for failure. All bolts must be tight and welds intact. Failure to verify the structural integrity of the machinery may result in workpiece shift, part ejection, operator injury or machinery damage.
- **Workpiece Inspection** Workpiece failure is the most common source of injury during press operations. Take time to thoroughly understand the workpiece. Never apply pressure to unstable objects, round shapes, balls, springs or any item with elastic, spring-back tendencies. Confirm the material properties of the workpiece will withstand the pressure to be exerted by the press. Confirm that workpiece items are stripped down to their simplest form. Many components contain unseen items that could fail during the press operation. Remove all sub components known to the workpiece prior to a pressing operation. Workpiece must be clean and free of substances at the pressing surface that would allow the pressing surfaces to slip under load.
- **Workpiece Support** Workpiece failure may be a result of improper or inadequate workpiece support. Adequate support for the workpiece must be present through the entirety of the press operation. Understand your workpiece and confirm that the workpiece support system you employ will withstand the pressure being exerted through the press operation.
- **Safe Use of Tooling** Edwards Manufacturing Company provides optional press tooling designed to provide for basic press applications. These tools are not designed to provide for all press applications. Care must be taken when selecting press tooling. Select tooling that is designed and rated for the specific application. Press with the shortest, most compact, tool length available. Confirm that press tooling and workpiece are aligned and follows a direct press path. Confirm that the correct press sleeve and arbor plate are used. Misaligned loads may fail the press tooling or workpiece and cause operator injury or damage to the machinery.

- **Special Fits** Not all parts were designed or engineered to be removed or applied with a press. When inspecting your workpiece, confirm any press tolerances, environmental, heating, cooling or fixative requirements that require special care prior to initiating the press operation. Do not proceed with a press operation without acknowledgment that the workpiece is pressable.
- **Do Not Force Press** Consider the rating of the press and the work at hand. Gradually build pressure being applied to the workpiece. Carefully observe the workpiece to avoid tooling misalignment or workpiece failure. Observe the press as it reacts under load. Do not overload the press. Under heavy press operation built up force is released when the pressed part breaks free of its mount. This release of pressure is sudden and can appear to shake the machinery. Take care to avoid parts falling from the workpiece.

Press Operation

1. For Operator safety, wear personal protective equipment, clear the work zone of any tooling or debris prior to powering the machinery on.
2. Perform press inspection.
3. Perform workpiece inspection.
4. Turn power source on.
5. Retract ram, install press tooling.
6. Adjust press bed as necessary to achieve the shortest distance between the press pin and workpiece. Confirm hardened pins are fully engaged with lynchpins secured.
7. Tighten retention bolts.
8. Safely load, position and support workpiece in press cavity.
9. Align and secure cylinder and ram over workpiece press site.
10. Confirm minimum table height to workpiece, alignment of ram and tooling to workpiece.
11. Carefully, slowly, extend ram and tooling to meet press site. Preload the workpiece and observe workpiece support and tooling alignment. Observe the preloaded condition from multiple angles to assure that the press tooling is in alignment with the ram and workpiece. If unstable, reverse ram, reset workpiece and re-align press tooling.
12. Gradually build pressure to complete the press operation. Do not overload the press.
13. Retract the ram to relieve hydraulic pressure following the press operation.

OPTIONAL TOOLING - BRAKE



WARNING

Press Brake tooling is available in a 12" assembly for the 20 Ton Shop Press, and Press Brake tooling ranging in size from 12" to 32" is available for the 40 Ton Shop Press. Brake tooling will allow for the graduated bending of 10 ga. x 32", 1/4" x 24", 3/8" x 6" flat stock up to 90 degrees.

Press brake tooling consists of a moving brake 'punch' and a stationary brake 'die'. The punch is held within a push block that is mounted upon two guide pin and spring assemblies fixed to the mounting plate. The die is held within two retaining brackets that are bolted to the mounting plate. Hydraulic force is applied to the push block assembly to activate the punch into the die assembly. Punches and dies are wearing parts and may need to be replaced over time. Contact your Edwards Dealer or the Factory for genuine Edwards replacement parts.

Setup

Turn off power to press by depressing the red stop / off button on the Edwards Ironworker or Edwards Porta-Power or lockout upstream power at the main electrical panel.

If press-brake tooling was ordered with your press, the tooling is already installed and ready for operation. If ordered as an option, your press-brake tooling ships on a pallet. **This tooling is heavy and is supplied with fork-lift installation hardware for safe and easy setup.**

Install the brake tooling by unbolting the brake tooling from the shipping pallet and inserting fork-lift forks through the 4 brackets bolted to the brake mounting plate. Once the forks are stable in the brackets, apply clamps (not supplied) to the forks beyond the brake to prevent the brake from slipping off forks during installation.

Prepare the Press cavity to accept the brake tooling. Clean the press bed of any tooling or debris. Confirm that the press bed is secure, the hardened pins are properly seated and secured with their retaining clips.

Carefully lift the brake tooling with forklift and guide into the press cavity. Lower the brake tooling to the press bed and align through bolt holes in the press brake base table with the bolt slots in the press bed flanges. When aligned, carefully remove the safety clamps from the forks and remove the forks from the lifting brackets.

Secure the brake table to the press bed with 4pcs - 3/8" x 2" cap-screw, washer and nut assemblies (not supplied).

Remove the 4 mounting brackets. Re-install the mounting bolts.

The 4-way bottom die is marked for 1/16", 3/16", 1/8" and 1/4" flat stock. Select the correct bottom die surface according to the material being used. Observe brake and material tolerances as listed in the tooling specifications and at the tooling station.

Apply standard press cup to ram end, center ram over press-brake tooling and power machine on.

Jog ram down to press brake push block and center within the cup centering guide. Once aligned, secure rolling cylinder to head frame by tightening retention bolt.

Safe Operation

Observe the following guidelines when operating Press Brake Tooling.

- Never exceed the capacities of the machine or tooling as described in the Ironworker specifications or listed at the tooling station.
- Keep the Brake tooling clean.
- Check Brake clearance and alignment at every tooling change, maintenance cycle or extended brake operation. Failure to maintain proper clearance may damage punch, die and support brackets or adjacent tooling.
- Brake material towards the center of the brake length.
- Do not stack material in the Brake station.
- Use Brake aids when working with small items at the Brake station.
- When not in use, remove the Brake die from the holder.

Brake Operation

1. Clear the Press Brake tooling station of any tools or debris prior to powering the machine on.
2. Turn your power source on and place the material to be "broken" on top of the bottom 4-way die.
3. **Center your material within the length of the bottom die.** Bending material 'off-center' to the ram may load the die unequally and produce poor quality parts, jam the push block on the guide pins and void the warranty on the tooling.
4. Position your material on the Brake die for the desired bend. Jog the 'punch' down to meet the material, clear your hands from the working area and depress the extend button on the hand control. Extend the ram to achieve your desired bend. When the operation is complete, retract the ram by pressing the retract button. Remove your material from the Press Brake tooling when the ram has fully retracted from the tooling and the tooling has returned to its neutral position.

OPTIONAL TOOLING - PRESS BRAKE TOOLING SET

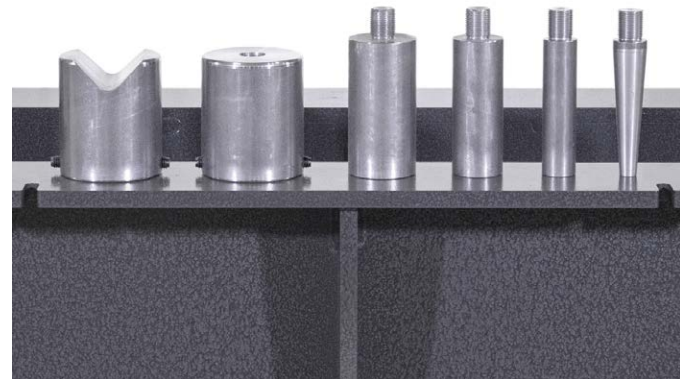

WARNING

Edwards Manufacturing Company provides optional press tooling designed to provide for basic press applications.

The Press Brake Tooling Set includes:

- 1 ea. 3" dia. x 3 1/2" V-Cup
- 1 ea. 3" dia. x 3 1/2" Threaded Cup
- 1 ea. 2" dia. x 4" Threaded Shaft
- 1 ea. 1 1/2" dia. x 4" Threaded Shaft
- 1 ea. 1" dia. x 4" Threaded Shaft
- 1 ea. 1" dia. x 4" Tapered Shaft

These tools are not designed to provide for all press applications. Choose your tooling according to the Operations section of this manual.

Press operations are dangerous and require extreme care and caution in the preparation of the material being worked, the press set-up and the pressing operation. Please refer to the following setup, safe operation and press operation sections for an understanding of potential hazards present in any pressing operation.

Setup

Turn off power to press by depressing the red stop / off button on the Edwards Ironworker or Edwards Porta-Power or lockout upstream power at the main electrical panel.

Your Shop Press was shipped with a standard press cup. A press cup protects the ram end of the cylinder during pressing operations. **NEVER PRESS DIRECTLY WITH CYLINDER RAM END. PRESSING WITH EXPOSED RAM END MAY DAMAGE THE MACHINED SURFACE, SCRATCH THE RAM AND DAMAGE THE CYLINDER AND VOID THE MANUFACTURER'S WARRANTY.**

Remove the standard press cup by relieving the ball-detent screws in the cup face. If utilizing the V – Cup press end, install by slipping the cup end over the ram end of the cylinder. Tighten the ball-detent screws in the V-Cup so that the cup fully engages the machined groove in the cylinder ram.

If utilizing the threaded or tapered shaft press tooling, note that this tooling threads into the 3" dia. x 3-1/2" Threaded Cup. Install threaded shaft ends into threaded cup and tighten so that the tooling is secure during the press operation. Once the threaded cup and threaded shaft are secure, install by slipping the cup end over the ram end of the cylinder. Tighten the ball-detent screws in the threaded-cup so that the cup fully engages the machined groove in the ram end of the cylinder.

Safe Operation

Observe the following guidelines when performing Press operations.

- **Operator Safety / Safe Work Zone** Applying pressure to parts or assemblies can fail the part being worked, fail a part adjacent to the work or fail the pressing tool. Failed parts can become airborne projectiles with deadly force. Protect yourself with appropriate personal protective equipment when operating the press. Protect others by defining a safe work zone for press use and limiting access to the press operator.
- **Press Inspection** Press operations may generate concussive failure to mechanical parts. Although Edwards press machinery is fabricated with both bolted and welded construction, concussive failure is a possibility over time or with extreme use. Prior to any Press operation, visually check all bolted and welded connections for failure. All bolts must be tight and welds intact. Failure to verify the structural integrity of the machinery may result in workpiece shift, part ejection, operator injury or machinery damage.
- **Workpiece Inspection** Workpiece failure is the most common source of injury during press operations. Take time to thoroughly understand the workpiece. Never apply pressure to unstable objects, round shapes, balls, springs or any item with elastic, spring-back tendencies. Confirm the material properties of the workpiece will withstand the pressure to be exerted by the Press. Confirm that workpiece items are stripped down to their simplest form. Many components contain unseen items that could fail during the press operation. Remove all sub-components known to the workpiece prior to a pressing operation. Workpiece must be clean and free of substances at the pressing surface that would allow the pressing surfaces to slip under load.
- **Workpiece Support** Workpiece failure may be a result of improper or inadequate workpiece support. Adequate support for the workpiece must be present through the entirety of the Press operation. Understand your workpiece and confirm that the workpiece support system you employ will withstand the pressure being exerted through the Press operation.

- **Safe Use of Tooling** Edwards Manufacturing Company provides optional press tooling designed to provide for basic Press applications. These tools are not designed to provide for all Press applications. Care must be taken when selecting Press tooling. Select tooling that is designed and rated for the specific application. Press with the shortest, most compact, tool length available. Confirm that Press tooling and workpiece are aligned and follows a direct press path. Confirm that the correct Press sleeve and arbor plate are used. Misaligned loads may fail the Press tooling or workpiece and cause operator injury or damage to the machinery.
- **Special Fits** Not all parts were designed or engineered to be removed or applied with a press. When inspecting your workpiece, confirm any press tolerances, environmental, heating, cooling or fixative requirements that require special care prior to initiating the press operation. Do not proceed with a Press operation without acknowledgment that the workpiece is pressable.
- **Do Not Force Press** Consider the rating of the Press and the work at hand. Gradually build pressure being applied to the workpiece. Carefully observe the workpiece to avoid tooling misalignment or workpiece failure. Observe the Press as it reacts under load. Do not overload the Press. Under heavy press operation built up force is released when the pressed part breaks free of its mount. This release of pressure is sudden and can appear to shake the machinery. Take care to avoid parts falling from the workpiece.

Press Operation

1. For Operator safety, wear personal protective equipment, clear the work zone of any tooling or debris prior to powering the machinery on.
2. Perform Press inspection.
3. Perform workpiece inspection.
4. Turn power source on.
5. Retract ram, install press tooling.
6. Adjust Press bed as necessary to achieve the shortest distance between the press pin and workpiece. Confirm hardened pins are fully engaged with linchpins secured.
7. Tighten retention bolts.
8. Safely load, position and support workpiece in press cavity.
9. Align and secure cylinder and ram over workpiece press site.
10. Confirm minimum table height to workpiece, alignment of ram and tooling to workpiece.

11. Carefully, slowly, extend ram and tooling to meet press site. Preload the workpiece and observe workpiece support and tooling alignment. Observe the preloaded condition from multiple angles to assure that the Press tooling is in alignment with the ram and workpiece. If unstable, reverse ram, reset workpiece and re-align Press tooling.
12. Gradually build pressure to complete the Press operation. Do not overload the Press.
13. Retract the ram to relieve hydraulic pressure following the Press operation.

OPTIONAL TOOLING - ROD SHEAR/MULTI-SHEAR



6. In the event that the push block and top die are not aligned, simply loosen the bolts under the table allowing the bump-die to be moved to center the push block with the moving center. When aligned, tighten the table bolts to secure the table.
7. Power the machine on and jog the center down. The moving blade will close or bypass the fixed blade. The push block should not come in contact with the die housing.

Safe Operation

Observe the following guidelines when operating any Rod Shear or Multi-Shear bump-die tooling.

- Never exceed the capacities of the machine or tooling as described in the Ironworker specifications or listed at the tooling station.
- Keep the tooling clean.
- Check blade clearance and alignment at every tooling change, maintenance cycle or extended tooling operation. Maintain .010 clearance between blades at all times. Failure to maintain clearance will damage blades and support pockets.
- Do not stack cut material.
- Perform complete shearing operations only – partial cuts may jam the tooling and could result in breakage and operator injury.
- Use shearing aids when working with small items at the Rod Shear or Multi Shear Tooling station

Rod Shear/Multi-Shear Operation

1. Clear the work area of any tools or debris prior to powering the machine on.
2. Turn the Ironworker or Porta-Power on and insert material through the tooling guard and into the blade area. Position your material for the desired cut.
3. Clear your hands from the working area and depress the extend button of the hand control to activate the tooling station.
4. When the cut is complete, press the retreat button of the hand control to automatically return the tooling to the neutral position.

WARNING

“Bump-die” tooling is available for your Edwards Shop Press. Rod Shear or Multi Shear Tooling will provide distortion and burr free cuts to mild steel rod, square, bar and small angle stock as listed in the Ironworker Accessories specification.

Setup

“Bump-die” tooling and accessories fit within the Shop Press. Edwards “bump-die” tooling consists of an adapter plate, a housing which holds a stationary blade, a moving blade, return springs, and a push block. The moving ram of the Shop Press “bumps” the top moving blade to shear the material. If ordered as a factory installed option, your “bump-die” assembly is setup for immediate operation. If ordered as an option, the cavity of the machine must be cleared of any existing tooling, material or debris prior to tooling installation. To setup your Rod Shear or Multi Shear Tooling please observe the following steps.

Turn off power to press by depressing the red stop / off button on the Edwards Ironworker or Edwards Porta-Power or lockout upstream power at the main electrical panel.

Install the bump-die assembly:

1. Remove all tooling and debris from the press table.
2. Place the 3/8" adapter plate on the press bed. Align bolt holes on plate with slotted holes in press bed.
3. Place the “bump-die” assembly on the press bed with the push block in line with the moving ram.
4. Secure the tooling to the press bed with four 1/2" bolts and washers (provided).
5. Check for push block and moving center alignment by powering on the machine and slowly inching down the center to meet the push block with the foot pedal. Power the machine off.

OPTIONAL TOOLING - PIPE NOTCHER



4. Align rolling cylinder over center of tooling push block. Secure press cup to ram end, power machine on and jog ram down to tool. Confirm press cup alignment with tooling push block. Once aligned, secure rolling cylinder to head frame by tightening retention bolt.

Install the Pipe notcher Assembly:

1. Place the Pipe-Notcher assembly on the Shop Press support table with the bottom die pointing away from the machine.
2. Loosely secure the table from the underside of the base with four 1/2" bolts and washers (provided).
3. Check for push block and top die alignment by powering on the machine and slowly inching down the ram to meet the top die with the foot pedal. Power the machine off.
4. In the event that the ram and top die are not aligned, simply loosen the bolts under the table allowing the table to be moved to center the push block centerline to the top blade. When aligned, tighten the table bolts to secure the table.
5. Power the machine on and jog the ram down. The pipe dies will close or bypass each other. The ram should not come in contact with the die housing.

WARNING

Pipe-Notch tooling will provide a distortion and burr free, notch cut to mild steel pipe and tube stock. Common use of this tooling is in the fabrication of saddle connections for motorcycle and race car tube frames, tube fences etc. Please review the capacity labels listed in the Ironworker Accessories specifications as well as positioned at the Pipe-Notching Station.

Setup

Pipe Notch tooling installs, with an adapter plate, within the working cavity of the Shop Press. Pipe Notch tooling for a shop press includes one top notcher die, one bottom notcher die and a die table. The top die is mounted within a spring loaded guide housing mounted to the die table. The bottom die attaches to the face of the guide housing and is machined with a saddle to aid in centering and guiding pipe sections into the die housing. The moving ram of the press cylinder pushes on the top blade to initiate the pipe notch. If ordered as a factory installed option, the pipe notcher assembly is set up for immediate operation. If ordered as an option, the open cavity of the press must be cleared of any existing tooling, material or debris prior to tooling installation. To set up your Pipe Notcher in an Edwards Shop Press, please observe the following steps.

Turn off power to press by depressing the red stop / off button on the Edwards Ironworker or Edwards Porta-Power or lockout upstream power at the main electrical panel.

Install the bump-die assembly:

1. Remove all tooling and debris from the press bed.
2. Place the 3/8" adapter plate on the press bed. Align bolt holes in the adapter plate with the slotted holes in the press bed. Secure plate to press bed with 2pcs - 3/8" x 2" capscrew, washer and nut assemblies (not supplied).
3. Place the bump-die tooling on the adapter plate and align base plate holes with adapter plate holes. Secure plate to press bed with 4pcs - 3/8" x 2" capscrew, washer and nut assemblies (not supplied).

Safe Operation

Observe the following guidelines when operating the Pipe Notch tooling.

- Never exceed the capacities of the machine or tooling as described in the Shop Press specifications or listed at the tooling station.
- Keep the Pipe Notcher tooling clean. When dirt or metal chips accumulate, remove 5/16-18 x 1/2" limit screw located in the center at the rear of punch. Lift out punch holder and two springs. Clean holder with solvent or kerosene.
- Check Pipe Notcher blade clearance and alignment at every tooling change, maintenance cycle or extended notcher operation. Maintain .010 clearance between notcher blades at all times. Failure to maintain clearance will damage blades and support pockets.
- Do not stack material to cut in the Pipe Notcher station.
- Perform complete notch operations only – partial notch cuts may jam the drop off side of the tooling and could result in breakage and operator injury.
- Use notching aids when working with small items at the notcher station.

Pipe Notcher Operation

1. Clear the feed table of the Pipe Notcher station of any tools or debris prior to powering the machine on.
2. Turn machine on. The top notcher die will be in the neutral position. Push the material into the blade area. Position your material to the desired cut.
3. Clear your hands from the working area and depress the extend button on the hand control to activate the Pipe Notcher. When the operation is complete, return the top cutting die to its neutral position by pressing the retract button.

TROUBLESHOOTING

WARNING

Quality parts are dependent upon conscientious setup, operation and maintenance of your Shop Press. Physically review your Shop Press prior to any operation. Confirm all static components are tight in the assembly. Confirm all moving components are free of obstruction. Confirm all tooling and assemblies are properly seated within the assembly.

Problem	Solution
Press Inoperable	<p>Check accessory control switch Check shop press male 4-pin power cable is connected to female limit switch port.</p> <p>Note: Auto Cut port will NOT power the Shop Press accessory.</p>
Rough cylinder operation	<p>Check fluid level of machine. Check hoses for correct installation. Check fuse at transformer box.</p>

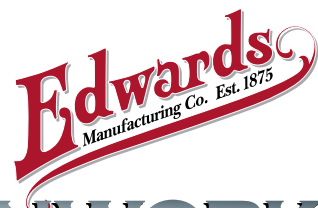

IRONWORKERS

P.O. Box 166, ALBERT LEA, MN 56007 800-373-8206 WWW.EDWARDSIRONWORKERS.COM



20 TON | 40 TON SHOP PRESS

SAFETY INSTRUCTIONS MANUAL



ORIGINAL INSTRUCTIONS - SHOP PRESS

SAFETY MANUAL

TABLE OF CONTENTS

1 GENERAL

- Operator and Supervisor Information
- Signal Word Definition
- Signal Word Panel

2 SHOP PRESS SIGNAL WORD PANEL

3 SIGNAL WORDS

- Danger Panel
- Warning Panel
- Caution Panel
- Notice Panel

OPERATOR AND SUPERVISOR INFORMATION

This is one of four manuals supplied with your machine.

- Installation Manual
- Safety Instructions Manual
- Operations Manual
- Maintenance Manual

READ ALL MANUALS BEFORE OPERATING MACHINERY. Operating machinery before reading and understanding the contents of all four manuals greatly increases the risk of injury.

Each of the four machine manuals describe 'best practices' in handling, installing, operating and maintaining your machine. The contents of each manual is subject to change without notice due to improvements in the machinery or changes in National or International standards.

All rights reserved. Reproduction of this manual in any form, in whole or in part, is not permitted without the written consent of Edwards Manufacturing Company.

Keep all manuals close to the machine to allow for easy reference when necessary.

Provide operators with sufficient training and education in the basic functions of the machine prior to machine operation.

Do not allow for operation of the machine by unqualified personnel. Edwards Manufacturing Company is not liable for accidents arising from unskilled, untrained operation.

Do not modify or change the machine without written authorization from Edwards Manufacturing Company. Unauthorized modification to a machine may result in serious operator injury, machine damage and will void your machine warranty.

Never leave a powered machine unattended. Turn machinery **OFF** before walking away.

This machine is manufactured for use by able bodied and able minded operators only. Never operate machinery when tired or under the influence of drugs or alcohol.

Do not resell, relocate or export to a destination other than to the original point of sale. Edwards has designed this machine to meet the standards of the original receiving country and is not liable for meeting any governing body or performance standards beyond those of the original receiving country.

SIGNAL WORD DEFINITION



Indicates a hazardous situation that, if not avoided, will result in death or serious injury.



Indicates a hazardous situation that, if not avoided, could result in death or serious injury.



Indicates a hazardous situation that, if not avoided, could result in mild or moderate injury.



Indicates information considered important, but not hazard related.

SIGNAL WORD PANEL ON MACHINE



Critical machine safety information is identified on signal word labels. Labels are attached adjacent to the potentially hazardous locations of the machine. Reference the Safety Instruction Manual for additional information regarding the potentially hazardous condition identified on the label.

Review ALL labels on the machinery, reference the operational precautions and safe operations sections within this manual before any operation activity is initiated.

Failure to read and understand the signal word labels affixed to the machinery may result in operator death or injury.

SHOP PRESS • SIGNAL WORD PANEL

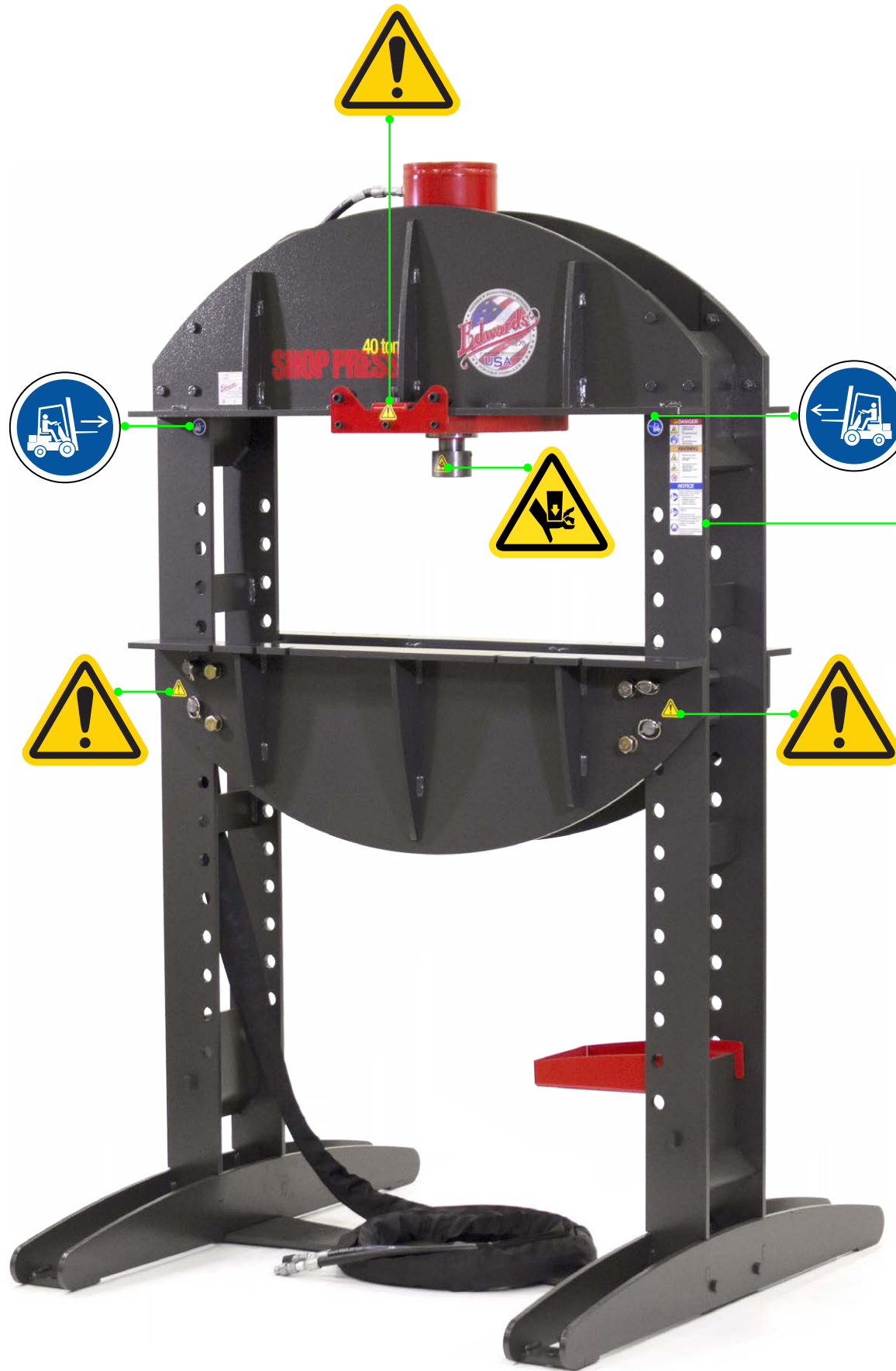

DANGER	
	Hydraulic accessory controls powered by Ironworker/Porta-Power.
	Lockout power at Ironworker/Porta-Power before servicing.
WARNING	
	Shear/Crush Hazard Moving parts can cut and crush.
	Fluid Injection Hazard Hydraulic fluid is under pressure. Hydraulic fluid powers moving parts.
	Keep guards in place
NOTICE	
	Read, understand, and follow all labels shown on the machine and described in the: • Safety Instructions Manual • Installation Manual • Operations Manual • Maintenance Manual
	Keep all manuals close for easy reference.
	Trained and authorized personnel are to install, operate and service this machinery. Do not allow for operation of the machine by unqualified personnel.
	Personal protective equipment must be worn at all times during machinery operation.

DANGER PANEL

DANGER



Electrical Hazard

This is the electrical hazard symbol. It indicates there are dangerous high voltages present inside the enclosure of this product. ONLY qualified, authorized, maintenance, service or Certified Electricians should gain access to electrical panel.



Lockout Power

Danger circuits are live. Lockout/Tagout the upstream power source.
Lockout / Tagout machinery according to Employer procedures.

WARNING PANEL

WARNING



Shear/Crush Hazard

Moving parts can cut and crush. Keep hands clear while operating. Lockout power before servicing. Immediately replace guards after adjustment, repair or service.



Wear Personal Protective Equipment

To avoid physical hazard, always wear personal protective equipment. Wear protective eyewear, clothing, gloves, footwear, head-gear and hearing protection while operating or servicing this machinery.



Fluid Injection Hazard

Hydraulic hoses and cylinders are under pressure. Pressurized fluid can pierce skin and cause severe injury. To avoid physical hazard, always wear personal protective equipment. Keep hands clear while operating. Lockout power before servicing. Immediately replace guards after adjustment, repair or service.

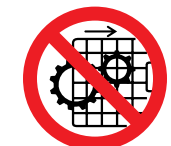

Do Not Operate With Guard Removed

Physical barriers and guards have been designed and installed to protect the Operator from moving parts that can pinch, cut and crush. Keep hands clear while operating. Lockout power before servicing. Immediately replace guards after adjustment, repair or service to moving parts.

CAUTION PANEL

CAUTION



Hardened Pins for Height Adjustment

Exercise caution when adjusting the height of the Shop Press.

NOTICE PANEL

NOTICE



Shop Press Operation

Edwards Hydraulic 20 and 40 Ton Press machinery are 'do-all' tools capable of many functions. This manual outlines the basic functions associated with typical press operations and is neither intended to create a comprehensive list of, nor describe every operation possible with a press tool. **Press operations are dangerous and require extreme care and caution in the safe installation, operation and maintenance of the machinery. Edwards Manufacturing Company strongly suggests reading and understanding all manuals associated with the machinery as well as obtaining certified, technical, industrial machinery operations and maintenance training to reduce the risk of injury. Regardless of the contents of the machinery manuals Edwards Manufacturing Company will not be held liable for accidents caused by lack of training.**



Refer to All Manuals

Each manual that comes with this machine contains critical instructions regarding proper operations, safety, installation and maintenance procedures. Understand the contents of each manual thoroughly. Failure to follow proper procedures may result in serious operator injury, machine damage and will void your machine warranty. Keep the manuals close to the machine for easy reference.



Wear Personal Protective Equipment

To avoid physical hazard, always wear personal protective equipment. Wear protective eyewear, clothing, gloves, footwear, head-gear and hearing protection while operating or servicing this machinery.



Forklift Location

This machine is equipped with rated forklift movement points. Do not attempt to lift the machinery by any other means. Inappropriate movement of the machinery may result in serious operator injury, machine damage and will void machine warranty. Consult the installation manual for equipment weight ratings. Provide rated forklift and certified forklift operator to move machinery to appropriate location.



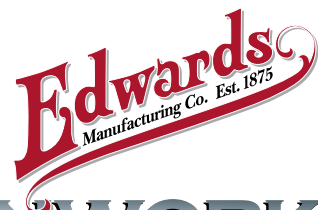

IRONWORKERS

P.O. Box 166, ALBERT LEA, MN 56007 800-373-8206 WWW.EDWARDSIRONWORKERS.COM