



1800 Watt Generator

Owner's Manual



⚠ WARNING: Read carefully and understand all ASSEMBLY AND OPERATION INSTRUCTIONS before operating. Failure to follow the safety rules and other basic safety precautions may result in serious personal injury.

Item #57599

READ & SAVE THESE INSTRUCTIONS

Thank you very much for choosing an Ironton™ product!

For future reference, please complete the owner's record below:

Serial Number/Lot Date Code: _____

Purchase Date: _____

Save the receipt, warranty, and this manual. It is important that you read the entire manual to become familiar with this product before you begin using it.

This generator is designed for certain applications only. Northern Tool and Equipment is not responsible for issues arising from modification or improper use of this product such as an application for which it was not designed. We strongly recommend that this product not be modified and/or used for any application other than that for which it was designed.

For technical questions, please call **1-877-234-6869**.

Table of Contents

Intended Use.....4

Technical Specifications4

Important Safety Information4

Before Each Use.....6

Operating Instructions.....11

Maintenance20

Parts Diagram for Engine21

Parts List for Engine22

Parts Diagram for Generator.....23

Parts List for Generator24

Replacement Parts25

Limited Warranty.....26

Intended Use

Ironton's 1800 Watt Generator can be used to power individual appliances plugged directly into the generator's outlets.

Technical Specifications

Property	Specification
Surge Watts	1800 Watts
Rated Watts	1400 Watts
Voltage	120 Volts
Phase	Single
Frequency	56.5-63.3 Hertz
Power Factor	1.0
Total Harmonic Distortion	Less than 23%
Engine	98cc OHV
Engine Speed	3600 RPM
Fuel Type	Unleaded Gasoline
Fuel Capacity	1.6 Gallons
Capacity	0.35 L
Starting Method	Recoil
120 Volt Receptacles	1-15 Amp (A) Duplex (NEMA 5-15R)
Circuit Breakers	1-8 Amp Thermal (push to reset)
	1-12 Amp Thermal (push to reset)
Length	18.3"
Width	14.2"
Height	15.9"
Dry Weight	56 lb.

HIGH ALTITUDE OPERATION

CAUTION: Operating at an altitude of greater than 2000 feet (610 meters) may affect your engines performance, fuel consumption, and emissions. To remain emissions compliant and improve engine performance at higher altitudes, a high-altitude kit is required. A high altitude kit includes a carburetor jet resized to help correct air / fuel mixture at altitude. To order a high altitude kit or if you have additional questions, go to www.northerntool.com or contact us at 1-877-234-6869. Please note, engines with the high-altitude kit installed operated at lower altitudes could cause severe engine damage and affect emissions compliance. When modified, a tag or decal should be added to the product stating that a high-altitude kit was installed and to remind you to re-service the carburetor (re-jet) when operating in lower altitude environments.

Note: Even with carburetor modification, engine horsepower will decrease about 3.5% for each 1,000-foot (300-meter) increase in altitude. The effect of altitude on horsepower will be greater than this if no carburetor modification is made.

Important Safety Information

⚠️ WARNING

- Read and understand all instructions. Failure to follow all instructions may result in serious injury or property damage.
- The warnings, cautions, and instructions in this manual cannot cover all possible conditions or situations that could occur. Exercise common sense and caution when using this tool. Always be

aware of the environment and ensure that the tool is used in a safe and responsible manner.

- Do not allow persons to operate or assemble the product until they have read this manual and have developed a thorough understanding of how it works.
- Do not modify this product in any way. Unauthorized modification may impair the function and/or safety and could affect the life of the product. There are specific applications for which the product was designed.
- Use the right tool for the job. DO NOT attempt to force small equipment to do the work of larger industrial equipment. There are certain applications for which this equipment was designed. This product will be safer and do a better job at the capacity for which it was intended. DO NOT use this equipment for a purpose for which it was not intended.

⚠WARNING

- This product can expose you to chemicals including gasoline engine exhaust, which is known to the State of California to cause cancer and, carbon monoxide, which is known to the State of California to cause birth defects or other reproductive harm. For more information, go to www.P65Warnings.ca.gov.
- Handling power cords on corded products may expose you to lead, a chemical known to the state of California to cause cancer and birth defects or other reproductive harm. Wash your hands after handling.

⚠WARNING

WORK AREA SAFETY

- Inspect the work area before each use. Keep work area clean, dry, free of clutter, and well-lit. Cluttered, wet, or dark work areas can result in injury. Using the product in confined work areas may put you dangerously close to cutting tools and rotating parts.
- Do not use the generator where there is a risk of causing a fire or an explosion; e.g., in the presence of flammable liquids, gases, or dust. The product can create sparks, which may ignite the flammable liquids, gases, or dust.
- Keep children and bystanders away from the work area while operating the generator. Do not allow children to handle the generator.
- Be aware of all power lines, electrical circuits, water pipes, and other mechanical hazards in your work area. Some of these hazards may be hidden from your view and may cause personal injury and/or property damage if contacted.

⚠WARNING

PERSONAL SAFETY

- Stay alert, watch what you are doing, and use common sense when operating the tool. Do not use the tool while you are tired or under the influence of drugs, alcohol, or medication. A moment of inattention while operating the tool may result in serious personal injury.
- Wear the proper personal protective equipment when necessary. Use ANSI Z87.1 compliant safety

goggles (not safety glasses) with side shields, or when needed, a face shield. Use a dust mask in dusty work conditions. Also use non-skid safety shoes, hardhat, gloves, dust collection systems, and hearing protection when appropriate. This applies to all persons in the work area.

- Do not overreach. Keep proper footing and balance at all times.

⚠CAUTION

GENERATOR USE AND CARE

- Check for damaged parts before each use. Carefully check that the product will operate properly and perform its intended function. Replace damaged or worn parts immediately. Never operate the product with a damaged part.
- Store the generator when it is not in use. Store it in a dry, secure place out of the reach of children. Inspect the tool for good working condition prior to storage and before re-use.
- Use only accessories that are recommended by the manufacturer for use with your product. Accessories that may be suitable for one product may create a risk of injury when used with another tool. Never use an accessory that has a lower operating speed or operating pressure than the tool itself.
- Do not leave the tool running unattended.

Before Each Use

There are a number of important steps required to set up your generator for initial use.

Unpacking and Inspecting Contents

Inspect the packaging immediately after receiving to be sure all parts are included. See the parts list and exploded view.

Preparing for Power Load to Stay within Generator's Rated Capacity

Plan your power load so that you do not exceed the generator's rated capacity.

1. Portable Power Source

You can plug appliances or tools directly into the generator's electrical outlets. When using the generator as a portable power source, you can plug electric devices and appliances directly into the generator's electrical outlets.

There is one kind of electrical outlets on the generator:

- Two 120 Volt, 15 Amp duplex straight-blade receptacles (NEMA 5- 15R duplex receptacles compatible with NEMA 5-15P mating plugs).

5-15R



Make sure you plug each electrical device/appliance into the correct generator outlet based on the device's plug configuration and voltage/amperage rating. Never exceed the amperage rating of an outlet.

Note: You must not overload the generator. Overloading the generator may cause serious damage to the unit and any attached electrical devices.

Extension Cords

Extension cords may be used to power devices that are located at a distance from the generator. However, use only outdoor-rated, grounded extension cords of the proper size. Use the table below to choose an adequately sized extension cord according to the amperage of the device being used and the length of the cord.

Current/Power	Maximum Extension Cord Length				
	Load (watts)	#10 Ga. Cord	#12 Ga. Cord	#14 Ga. Cord	#16 Ga. Cord
Amps at 240V					
10	2400	250'	150'	100'	75'
20	4800	125'	75'	50'	25'
30	7200	60'	35'	25'	10'
40	9600	30'	15'	10'	
50	12000	15'			

⚠️ WARNING

- Use of under sized extension cords can cause electric shock, fire, or damage to connected devices.
- Use of damaged electric cords can cause electric shock or fire.
- All extension and appliance cords must be in good condition and not worn, bare, frayed, or otherwise damaged.

Note: If an extension cord becomes hot to the touch, it is overloaded or damaged and must be replaced. The distributors are NOT responsible for damage or injury resulting from customer use of inadequate extension cords.

Selecting a Site for Use

Before using the generator, you must select a suitable OUTDOOR location for installation and operation. This location should meet all of the criteria listed below.

⚠️WARNING

You must choose a suitable site for operating your generator to avoid equipment damage and/or injury and possible death from carbon monoxide poisoning, electric shock, or fire. Choose a site that meets all of the criteria specified.

1. Dry, Level Surface

The generator should be positioned on a dry, firm, level surface. Ensure that the generator sits level and will not slide or shift during operation. If applicable, block the generator's wheels to prevent sliding and shifting.

2. Outdoors Only

⚠️WARNING

The exhaust from your generator contains carbon monoxide (CO), a poisonous gas that can kill. You cannot smell it, see it, or taste it. Carbon monoxide exhaust is given off whether you are using gasoline, natural gas, or propane as the fuel source to power the generator. Follow the directions below for choosing a location to operate your generator in order to avoid carbon monoxide poisoning.



The location you choose to operate the generator must be outdoors and away from all air intakes:

- Never run the generator inside any closed or semi-enclosed spaces (even if outdoors), including homes, garages, basements, sheds, or boxes. These spaces can trap poisonous gases, even if you run a fan or open windows.
- Place the generator so that the exhaust fumes will not be directed towards people or building air intakes.

- Ensure that working, battery-operated, or battery back-up carbon monoxide alarms are used in any dwelling/structure that is in close proximity to the running generator.
- This generator is NOT designed or approved for use in vehicles or marine applications. Never run the generator inside RVs or other vehicles, on boats, or on pick-up truck beds.

⚠WARNING

Never attempt to attach duct-work to the muffler system to allow for installation inside an enclosure. This could cause hot air deflection, heat build-up, and increased exhaust back-pressure, resulting in possible exhaust leakage or damage to the generator.

3. Adequate Cooling Ventilation

The generator needs adequate, unobstructed flow of air to allow for proper cooling of engine and generator head.

⚠WARNING

Heat build-up from inadequate ventilation can result in fire, posing a serious risk to nearby persons and structures.

- Situate so there is adequate clearance around generator to allow for cooling airflow so that heat does not build up.
- Never place the generator immediately adjacent to a building or other structure. Allow at least 7 feet clearance.
- Do not run the generator in close proximity to other heat-generating equipment, such as another generator. The combined heat that is generated may raise air temperature in the immediate area and there will not be adequate cooling ventilation.
- Do not allow debris to accumulate and block airflow.
- Do not operate with a tarp, blanket, or cover surrounding the generator.

4. No Wet Conditions

Choose a location where the generator will NOT be exposed to rain, snow, or direct sunlight. Exposure to water can cause electric shock.

You may operate the generator under an outdoor, canopy-like structure of heat-resistant material that is open on all sides. Make sure that all parts of canopy are at least 7 feet from exhaust, and allow for adequate clearance above generator so that heat does not build up.

5. Hot Exhaust Clearance

The exhaust gas from your generator is extremely hot and can cause combustible materials to catch on fire.

- Make sure your generator's exhaust system is at least 7 feet from all combustible materials and buildings/structures.
- Equip the engine with a spark arrestor if the generator will be used near any ignitable forest, brush, or grassy land. (See the Specifications section of this manual to determine if your

generator is already equipped.) Make sure you comply with applicable local, state, and federal codes.

- Keep a fire extinguisher rated "ABC" nearby. Keep it properly charged and be familiar with its use.

6. Away from Dust and Dirt

Do not use the generator in extremely dusty or dirty conditions. Excessive dust and dirt can cause premature failure of the machine.

7. Hearing Protection

Generators can produce noise levels of up to 95 dB in close proximity, which can be dangerous to human hearing with prolonged exposure.

Hearing protection may be required for persons working within 15-20 feet of the running generator for an extended period of time.

⚠ WARNING

Never attempt to attach ductwork to the muffler system to lower noise levels. This could cause hot air deflection, heat build-up, and increased exhaust back-pressure, resulting in possible exhaust leakage or damage to the generator.

Grounding the Generator

Always ensure the generator is properly grounded to prevent electrical shock. You must always ground the generator by the following method when using the generator as a portable electrical source:

1. Drive a $\frac{3}{4}$ " or 1" copper pipe or rod into the ground close to the generator. The pipe/rod must penetrate moist earth – the depth required will be dictated by local soil conditions. Consult with an electrician.
2. Connect an approved ground clamp to the pipe.
3. Run a 10 gauge wire from the clamp to the generator grounding post located on the rear of the generator head.
4. Do not connect the generator grounding post to a water pipe or a ground used by a radio system.

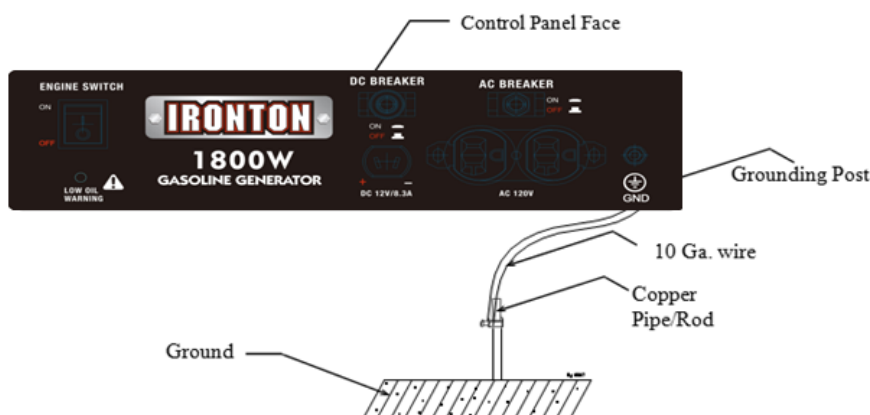

⚠WARNING

Operating the generator when it is not properly grounded can result in electrical shock.

Operating Instructions

Once you have set up the generator for use, it is time to start the unit. The following are the procedures necessary for safe, successful operation of your generator.

General Safety Rules for Operation

⚠WARNING

Failure to follow safety rules may result in serious injury or death to the operator or bystanders.

Before starting the generator, review the following general safety rules for operation:

Know proper use/how to stop. Be thoroughly familiar with proper use of the equipment and all generator controls, output receptacles, and connections. Know how to stop the generator quickly if needed.

Instruct operators. The generator owner must instruct all operators in safe generator set-up and operation. Only trained adults should set up and operate the generator – Do not let children operate.

Intended use. Carefully read about and understand the intended use of this generator. Do not use for other purposes, as unforeseen hazards or equipment damage may result.

Under the influence. Never operate, or let anyone else operate, the generator while under the influence of alcohol, drugs, or medication.

Safety equipment / controls. Do not operate the generator unless all safety covers, guards, and barriers are in place and in good working order, and all controls are properly adjusted for safe operation.

Damaged. Do not operate the generator with damaged, missing, or broken parts.

Modifications. Do not modify the generator in any way. Modifications can create serious safety hazards and will also void the warranty.

Engine speed. Never attempt to modify the engine speed setting. The engine speed is preset at 3600 RPM for safe and optimal performance of the generator. If speed needs adjusting, it must be done by factory- authorized personnel.

External fuel sources. Never attempt to connect external gasoline/diesel sources in order to increase engine run time. Larger tank at pressure or higher elevation will cause gasoline to leak from carburetor during operation. Fire or explosion could result.

Malfunction during operation. Immediately turn off the generator if any of the following conditions arise during operation:

- Excessive change in engine speed, slow or fast
- Overheating in load connecting devices
- Sparking or arcs from generator

- Loss of electrical output
- Receptacle damage
- Engine misfire
- Excessive vibration
- Flame or smoke
- Abnormal noise

Adjusting / repairing. Always turn off generator and remove spark plug(s) or spark plug wire(s) before working on the generator to prevent accidental starting. Always discharge the capacitor before working on the generator head to prevent electrical shock. (See Maintenance & Repair section of this manual for instructions on how to do this.)

Carbon monoxide poisoning. The running engine gives off carbon monoxide, a poisonous gas that can kill you. You CANNOT smell it, see it, or taste it. Follow all instructions for site selection and positioning the generator, and avoid inhaling the exhaust. If you start to feel sick, dizzy, or weak while using the generator, shut off the engine and get to fresh air RIGHT AWAY. See a doctor. You may have carbon monoxide poisoning.

Other exhaust dangers. This product contains or emits chemicals known to the State of California to cause cancer, birth defects or other reproductive harm. Avoid inhalation of exhaust.

Wet conditions. Do not operate the generator or handle any electrical equipment while standing in water, while barefoot, while hands are wet or while in the rain or snow. Electric shock may result.

Ground fault circuit interrupter. Always use a ground fault circuit interrupter (GFCI) protected extension cord (or outlet, if generator is equipped) in damp or highly electrical conductive areas and on construction jobsites to prevent electrical shock.

Avoid contact. Avoid contact with bare wires, terminals, connections, etc., while the unit is running.

Electric shock accident. If an electric shock accident occurs, immediately shut down the source of electrical power. If this is not possible, attempt to free the victim from the live conductor. Avoid direct contact with victim. Use a non-conducting implement, such as a dry rope or board, to free the victim from the live conductor. Apply first aid and get immediate medical help.

Smoking/sparks. Never smoke near the running generator, and never operate near sources of sparks or flames.

Hot muffler. Never touch hot muffler, hot exhaust manifold, or engine cooling fins. Exhaust and engine parts can be very hot and will burn you.

Moving parts. Keep hands, feet, and apparel away from drive belts, fans, and other moving parts. Never remove any drive belt or fan guard while the unit is operating.

Static electricity and filling the gasoline tank. Static electricity can initiate from ungrounded gasoline tanks or containers, from flowing gasoline, and from persons carrying a static electric charge.

Static electricity can explosively ignite gasoline vapors that are present during the fueling process, resulting in serious burns to nearby persons. To avoid static electricity while fueling, certain steps must be followed before and during the fueling process in order to minimize and safely dissipate static charge build-up:

- Touch a grounded metal object before starting. Always dissipate static charge from your body before beginning the fueling process by touching a grounded metal object at a safe distance away from fuel sources.
- Use a portable container to fill tank. Never fill the generator's gas tank directly from the fuel pump -the generator's tank is not grounded and the high velocity flow of gasoline from a fuel pump can cause static electric build-up. Use an approved portable container to transfer gasoline to the generator's tank.
- Fill container on the ground. Never fill the portable gas container while it is sitting inside a vehicle, trailer, trunk, or pick-up truck bed. ALWAYS place container on the ground to be filled.
- Keep nozzle in contact with container. Keep nozzle in contact with the portable container at all times while filling. Manually control the flow of gasoline; do NOT use the nozzle's lock- open device.
- Use a portable container made of metal or conductive plastic. It will dissipate charge to the ground more readily.

Static Electricity and Fueling

Many common objects can accumulate and retain a static electric charge. Objects made of non-conductive materials (e.g., plastics) easily accumulate and retain static electric charge, as can objects made of conductive material (e.g. metal, water) if they are not electrically grounded. The static electric charge on an object, such as a human body or plastic fuel tank/container, can reach as high as several thousand volts!

A static electric spark can be generated if the static electric charge stored on an object "jumps" to another, less charged object. Such a spark can ignite invisible gasoline vapors that are present during fueling situations.

Typical Sources of Static Electric Hazards During Fueling

The following objects can accumulate a static electric charge and cause an ignition spark in typical fueling situations:

- Ungrounded tanks/containers. Any ungrounded fuel tank or container can accumulate a static electric charge as a result of contact with other objects or friction during transportation. This static electricity can discharge as a spark to the grounded gasoline dispenser nozzle, as the nozzle is first brought close to the tank/container at the beginning of the fueling process.
- Flowing gasoline. It is important to note that gasoline accumulates static electric charge while flowing through a hose or pipe. This charge then transfers to and accumulates in the gas tank or container that is being filled. The total amount of charge accumulation depends on the amount of gas pumped into the container, the speed with which it is pumped, and whether or not the tank/container is grounded. If sufficient static electric charge accumulates in the fuel tank or container during the fueling process, the tank/container may discharge a spark to the grounded gasoline dispenser nozzle.
- Persons. A person dispensing the gasoline can carry a static electric charge on their body, typically resulting from contact with their car seat or electronics. The static electricity can discharge as a spark between that person's hand and either the grounded dispenser nozzle or the fuel tank opening.

Preparing for Operation

Position generator. Use the instructions provided under Before Each Use/Selecting a Site. Operate outside only, on dry, level ground with adequate clearance and ventilation.

⚠️WARNING

Carbon monoxide poisoning hazard. Generators give off carbon monoxide exhaust, a poisonous gas that can kill. You CANNOT smell it, see it, or taste it. ONLY run generator OUTDOORS and away from air intakes. NEVER run generator inside any enclosed or semi-enclosed spaces, including homes, garages, basements, sheds, boxes, pick-up truck beds, RVs, or boats. These spaces can trap poisonous gases, EVEN if you run a fan or open windows. Carbon monoxide exhaust is given off whether you are using gasoline, natural gas, or propane to power the generator.

Ground generator. Make sure the generator is grounded in accordance with instruction given in the Before Use/Grounding the Generator section of this manual.

⚠️WARNING

Electric shock hazard. Always ensure generator is properly grounded to prevent electrical shock.

Perform scheduled maintenance as needed. Make sure that any regular maintenance has been performed as prescribed in this manual in the Maintenance & Repair section.

1. Refer to the engine owner's manual for engine maintenance instructions.
2. Make sure battery is charged. Charge as needed according to your battery manufacturer's instructions.

Check /add oil. Check the oil level using the dipstick and add oil as needed. Using a funnel, add oil up to the FULL mark on the dip stick with the recommended oil type for your engine and expected ambient conditions.

⚠️WARNING

Burn hazard. Never open oil port while engine is running. Hot oil can spray over face and body.

Note: The low oil shut-down feature prevents the generator from starting without sufficient oil. Engine is shipped without oil. You must add oil before first use.

IMPORTANT: Under long, continuous-run operating conditions, be prepared to:

- Check engine oil level every time you refuel the engine.
- Change oil after the first 20 operating hours, and at least every 100 operating hours thereafter, or as directed in engine owner's manual.

Check/fill gasoline tank. Check the gasoline level in the generator's tank. If needed, fill tank with fresh unleaded gasoline from a portable container, after first reading the warnings and instructions below.

⚠️WARNING

Gasoline fire/explosion hazard. Gasoline is highly flammable and explosive. Heat, sparks, and flames can ignite gasoline vapors, which can become widespread during fueling. A flash fire and/or

explosion could result and cause serious injury or death. Use extreme care when handling gasoline. Carefully follow all the instructions in this section to avoid the following conditions which could result in gasoline ignition:

- Gas vapor collection inside enclosures
- Static electric sparks
- Sparks from electric wiring, batteries, or running engines
- Sources of heat (such as a hot engine or exhaust)
- Open flames, including pilot lights

1. Before starting, review the following general safety precautions for fueling:

- a) Never pump gasoline directly into the generator's gas tank at a gas station - high velocity flow from the pump could result in a static electric build-up in the generator's tank. Always use a portable container to fill the tank. See warning box about static electric spark hazards below.
- b) Fill gasoline tank OUTDOORS, never indoors.
- c) Stay away from all sources of heat, sparks, and flames. Do not smoke.

2. Turn generator engine off and allow to cool for at least two minutes before removing gas cap.

Note: A running or still-hot engine is hot enough to ignite fuel.

3. Remove generator gasoline cap.

4. Add gasoline through the fill opening:

- a) Follow the safety warning and instructions below for avoiding static electric sparking.
- b) Do NOT overfill the gasoline tank. Allow at least 1/2 inch of empty space below the fill neck to allow for fuel expansion.

⚠WARNING

Static electric spark hazard. A static electric spark can explosively ignite gasoline vapor, resulting in a flash fire that could cause serious injury or death.

To avoid static electric sparking while filling the gasoline tank, the following steps must be followed to minimize and safely dissipate static electric charge build-up before and during the fueling process:

- Always dissipate static charge from your body before beginning the fueling process by touching a grounded metal object at a safe distance from fuel sources.
- Never fill the generator's gas tank directly from the fuel pump -the generator's tank is not grounded and high velocity flow from the pump can cause static electricity build-up. Use an approved portable container to transfer gas to the generator's tank.
- Never fill the portable gas container while it is sitting inside a vehicle, trailer, trunk, or pick-up truck bed. ALWAYS place container on the ground to be filled.
- Keep nozzle in contact with portable container while filling. Manually control the flow of gasoline; do NOT use the nozzle's lock-open device.
- A portable container made of metal or conductive plastic is preferred because it dissipates charge to ground more readily.

5. Clean up gasoline spills/splashed immediately.

- If possible, move the generator away from spilled gasoline on the ground.
 - Wipe up spilled gasoline, and wait 5 minutes for excess gasoline to evaporate before starting engine.
 - Gasoline soaked rags are flammable and should be disposed of properly.
 - If gasoline is spilled on your skin or clothes, change clothes and wash skin immediately.
6. Replace gasoline cap securely before starting engine.
 7. Store extra gasoline in a cool, dry place in an UL listed, tightly sealed container.

IMPORTANT: For continuous operation, be prepared to check and refuel the engine on a regular basis. A tank of gasoline should last about 9.0 hours under 50% load.

Inspect fuel system/check for leaks. Inspect fuel system & check for leaks BEFORE starting generator. Do not start generator until all needed repairs have been completed.

Personal Protection. Hearing can be damaged from prolonged, close-range exposure to the type of noise produced by this generator. The use of ear plugs or other hearing protection device is recommended for persons working within 15-20 feet of the running generator for an extended period of time. Loose or dangling apparel can become entangled in moving parts. Metal jewelry can conduct electricity. Never wear jewelry or loose-fitting clothing when starting or operating the generator.

Starting the Engine

After you have completed the pre-start checklist procedures, you are ready to start the engine

1. Disconnect all loads to the generator.
2. Turn the gasoline line valve to the ON position.
3. For a cold engine, move the choke lever to the full choke position. To restart a warm engine, move the choke lever to half choke or to the RUN position.
4. Start the engine:
 - a. Using electric start:
 - i. Turn the engine key switch to the START position and hold it there until the engine starts.

Note: If the engine fails to start after 5 seconds, release key and wait 10 seconds before attempting to start again. Cranking the electric starter for more than 5 seconds continuously can overheat and damage the starter motor.

- ii. Release the key when the engine starts.
- b. Using recoil start -
 - i. Turn the engine key switch to the ON position.
 - ii. Pull the starter grip lightly until you feel resistance, then pull the starter cord out briskly and rapidly.
 - iii. Allow starter cord to return slowly.

5. When engine starts, move choke lever to RUN position.
6. Under long, continuous-run operating conditions, be prepared to:
 - a. Check and refuel the engine on a regular basis. A tank of gas should last about 9.0 hours under 50% load.

⚠WARNING

A running engine is hot enough to ignite fuel. Never add fuel or remove gas cap if engine is running or still hot. Let cool at least 2 minutes.

- b. Check engine oil level each time you refuel.
- c. Change oil after the first 20 operating hours, and at least every 100 operating hours thereafter, as directed in the engine owner's manual.

⚠WARNING

Never open oil port while engine is running. Hot oil can spray over face and body.

Checking Generator Output

Although the speed of the engine was carefully adjusted at the factory so that the generator produces the proper voltage and frequency, output voltage should be checked periodically to ensure the generator is working properly before connecting loads to the generator.

⚠WARNING

The generator must be run at the correct speed in order to produce the proper electrical voltage and frequency. Failure to do so could result in damage to equipment powered by the generator and possible injury to the individual.

Output voltage should be checked with a portable voltage meter:

1. Start engine and allow to warm up for five minutes. Do not connect any loads.
2. Use voltage meter to check output voltage at the generator's outlets/receptacles.
3. Measured voltage should be within the following ranges:
 - a. 120V +/- 10% at 120V receptacles.
4. If measured voltage is not within the specified range, have generator adjusted by factory authorized personnel. Do not attempt to adjust the engine speed yourself.

Note: There is a slight variation in voltage/speed with changing electrical loads. All engines have a tendency to slow down when a load is applied. When electrical loads are connected to the generator, the engine is more heavily loaded and as a result, the speed drops slightly.

This slight decrease in speed, together with the voltage drop within the generator itself, results in a slightly lower voltage when the generator is loaded to its full capacity than when it is running with no load. Additionally, there may be small brief surges and drops in voltage as motors connected to the generator cycle on or off. The slight variation has no appreciable effect in the operation of motors, lights, and most appliances.

Connecting Electrical Loads (Portable Power Generation)

You will want to be careful when connecting loads so as not to overload the generator, especially if you are powering devices with motors that require a higher starting power load.

⚠WARNING

Do not overload generator. Make sure that combined starting and running loads do not exceed rated capacity of generator. Overloading the generator can cause damage to the generator and attached electrical devices, and may result in fire.

Using as a Portable Power Source. Connect electrical loads one at a time according to the following instructions:

1. Allow engine to reach operating speed by allowing it to warm up for approximately 5 minutes before connecting electrical devices.
2. After engine is warmed up, begin by connecting the items that require the highest wattage first. The recommended sequence is as follows:
 - a. Connect items with motors such as refrigerators, freezers, air conditioners, or small hand tools, one at a time. Let each motor stabilize before connecting the next device.
 - b. Connect any lights you are planning on powering.
 - c. Connect voltage sensitive equipment such as electronics via surge protectors. Plug devices such as televisions, computers, and microwaves into a UL listed voltage surge protector, then plug the surge protector into the generator.

Stopping

Stop the engine using the following steps:

1. Disconnect all loads to the generator.
2. Turn the engine key switch to the OFF position.
3. Turn the gasoline line shut off valve to the OFF position.
4. Remove the key from the starter to prevent accidental starting of the engine.

Storage & Exercise of Generator

When you are finished using the generator, you must:

1. Disconnect all loads to the generator.
2. Turn the engine key switch to the OFF position.
3. Store the generator properly
4. Plan on exercising the engine regularly unless the generator is prepared for long-term storage.

Disconnect loads and turn off fuel supply. When you are finished using the generator, disconnect all loads and turn off fuel supply:

1. Make sure all devices that were connected to the generator's outlets have been disconnected.

2. Check to be sure gasoline line shut-off valve is in OFF position.

Cool engine before storing. Let engine cool for at least five minutes before storing. A hot engine can be a fire hazard.

Choose a storage location. Store the generator in a location that is:

- Clean and dry.
- Away from sources of heat, open flames, sparks, or pilot lights, even if the generator's fuel tank is empty. Residual fuel in the tank could ignite.
- Away from extreme high or low temperatures.

Note: Do not store with battery charger always connected. Batteries that are over-charged can boil themselves dry and produce excessive amounts of hydrogen, an explosive gas.

Prevent accidental starting. Remove key from starter (for electric start engines) and secure key in a safe location, or remove spark plug(s) in order to ensure the generator cannot be started accidentally in a storage location or by untrained persons.

Exercise generator every 4 weeks. The generator should be run regularly. At least every four weeks, start the engine and let it run for 10 to 15 minutes with a small load plugged in, such as a lamp or fan. Monthly using of the generator will:

- Dry out any moisture that has accumulated in the windings. If left, this moisture can cause corrosion in the winding.
- Ensure that the unit is operating properly should it be needed in an emergency.

Perform regular maintenance. Perform periodic maintenance as directed in this manual to keep the generator in safe working condition.

Maintenance

Maintain the product by adopting a program of conscientious repair and maintenance in accordance with the following recommended procedures. It is recommended that the general condition of any tool be examined before it is used. Keep your generator in good repair. Keep handles dry, clean, and free from oil and grease. The following chart is based on a normal operation schedule.

Follow safety rules	<p>Read and follow these safety rules whenever you will be servicing the generator:</p> <ul style="list-style-type: none"> • Turn off generator. Always turn off generator and remove spark plug(s) or spark plug wire(s) before working on the engine or generator to prevent accidental starting. • Replace guards. Make sure all guards and shields are replaced after servicing the generator. • Repair. Major service, including the installation or replacement of parts, should be performed only by a qualified electrical service technician. • Replacement parts. If a part needs replacement, only use factory approved repair parts. Replacement parts that do not meet specifications may result in a safety hazard or poor operation of the generator and will void the warranty.
Perform engine maintenance	<p>Perform engine maintenance as specified in the engine owner's manual. Engine maintenance items include:</p> <ul style="list-style-type: none"> • Changing oil and oil filter • Air filter check/replacement • Spark plug cleaning and replacement • Fuel filter check/replacement • Fuel tank cleaning
Check receptacles	<p>Check receptacles before each use to make sure they are not cracked or broken.</p> <p>If a receptacle is cracked or otherwise damaged, do not use until replaced with an authorized factory part. Using cracked or damaged receptacles can be both dangerous to the operator and destructive to the equipment.</p>
Inspect fuel system/check for leaks	<p>Inspect the fuel system and check for leaks on a regular basis.</p> <p>Inspect the entire fuel system. Look for signs of leaks or deterioration, chafed or spongy fuel hose, loose connections, loose or missing fuel hose clamps, damaged gasoline tank, or defective gasoline shut-off valve.</p>
Check GFCI (if equipped)	<p>Once a month, test the Ground Fault Circuit Interrupter (GFCI) to protect against electrical shock due to failure of the GFCI. (Only for those models equipped with GFCI -See the Specifications section.)</p>

Parts Diagram for Engine

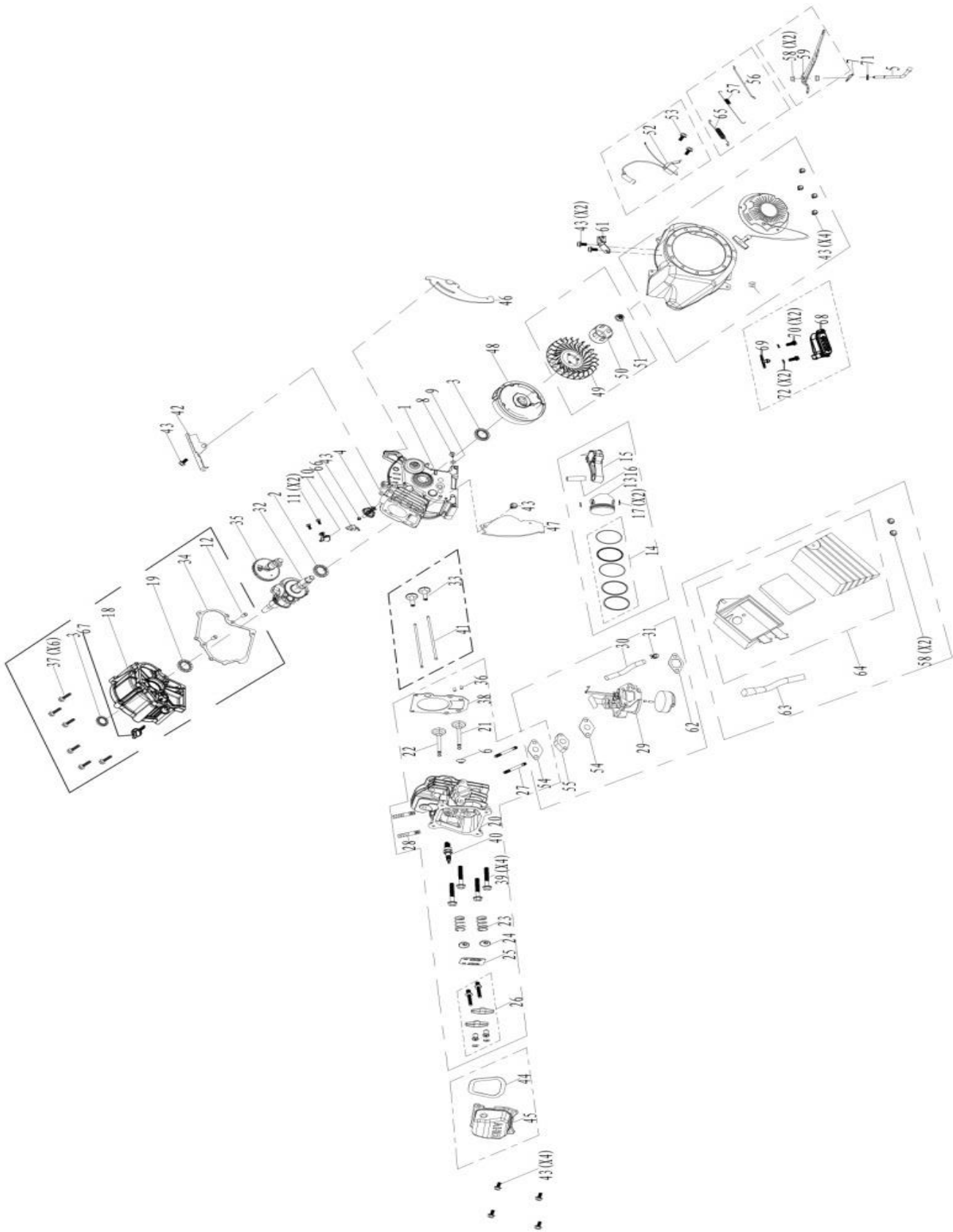

Parts List for Engine

Ref.	Part Number	Part Description	Qty.
1	220203	CRANKCASE	1
2	93005	BALL BEARING	1
3	93502	OIL SEAL	2
4	224301	GOVERNOR ASSEMBLY	1
5	223901	SHAFT, GOVERNOR ARM	1
6	241805	RETURNER, INTAKE VALVE	1
7	243902	PIN, LOCK	1
8	91816	BOLT, DRAIN PLUG	1
9	94007	WASHER, DRAIN PLUG	1
10	225102	SWITCH ASSEMBLY, OIL LEVEL	1
11	91303	BOLT M6X12	2
12	240901	DOWEL PIN, CASECOVER	2
13	221203	PISTON	1
14	221603	SCRAPER RING SET , PISTON	1
15	221501	ROD ASSEMBLY, CONNECTING	1
16	225501	PIN, PISTON	1
17	221301	CLIP, PISTON	2
18	220104	COVER ASSEMBLY, CRANKCASE	1
19	93019	BALL BEARING	1
20	221004	CYLINDER HEAD	1
21	221701	VALVE, IN	1
22	225902	VALVE EXHAUST	1
23	226001	SPRING, VALVE	2
24	241801	SEAT, VALVE SPRING, IN	2
25	222201	PLATE, PUSH ROD GUIDE	1
26	222101	ROCKER ASSEMBLY	2
27	91023	BOLT, STUD	2
28	91007	BOLT, STUD	2
29	222802	CARBURETOR ASSEMBLY	1
30	95409	FUEL LINE $\Phi 4 \times \Phi 8 \times 120$ mm	1
31	94409	CLIP, FUEL LINE $\Phi 9.5$	1
32	220310	CRANKSHAFT ASSEMBLY	1
33	226101	LIFTER, VALVE	2
34	96027	PACKING, CASECOVER	1
35	222003	CAMSHAFT ASSEMBLY	1
36	220901	PIN, DOWEL	2

Ref.	Part Number	Part Description	Qty.
37	91333	BOLT M6X28	6
38	96029	GASKET, CYLINDER HEAD	1
39	91352	BOLT M8X50	4
40	97101	SPARK PLUG	1
41	221901	ROD, PUSH	2
42	220504	SHROUD	1
43	91325	BOLT M6X12	13
44	96045	PACKING, HEADCOVER	1
45	241107	COVER COMP, CYLINDER HEAD	1
46	220502	WIND SHIELD, LH	1
47	220503	WIND SHIELD, RH	1
48	220401	FLYWHEEL ASSEMBLY	1
49	224601	FAN, RECOIL STARTER	1
50	224501	PULLEY, STARTER	1
51	90014	NUT M12	1
52	97507	IGNITION COIL ASSEMBLY	1
53	91330	BOLT M6X20	2
54	96032	PACKING, INTAKE	2
55	222301	INSULATOR, CARBURETOR	1
56	222701	ROD, GOVERNOR	1
57	224202	SPRING, THROTTLE RETURN	1
58	90010	NUT M6	4
59	224001	GOVERNOR ARM	1
60	224703-010	RECOIL STARTER ASSEMBLY	1
61	224402	SHROUD ASSY, UPPER	1
62	96035	GASKET, AIR CLEANER	1
63	95602	TUBE, BREATHER	1
64	222902	AIR CLEANER ASSEMBLY	1
65	224103	SPRING, GOVERNOR	1
66	245104	AMPLIFIER	1
67	225602	DIPSTICK	1
68	545901	SECONDARY GAS INJECTION FILTER	1
69	229902	FLAMEOUT WIRE	1
70	91302	BOLT M6X12	2
71	96803	WASHER, GOVERNOR ARM SHAFT	1
72	94205	SPRING WASHER	2

Parts Diagram for Generator

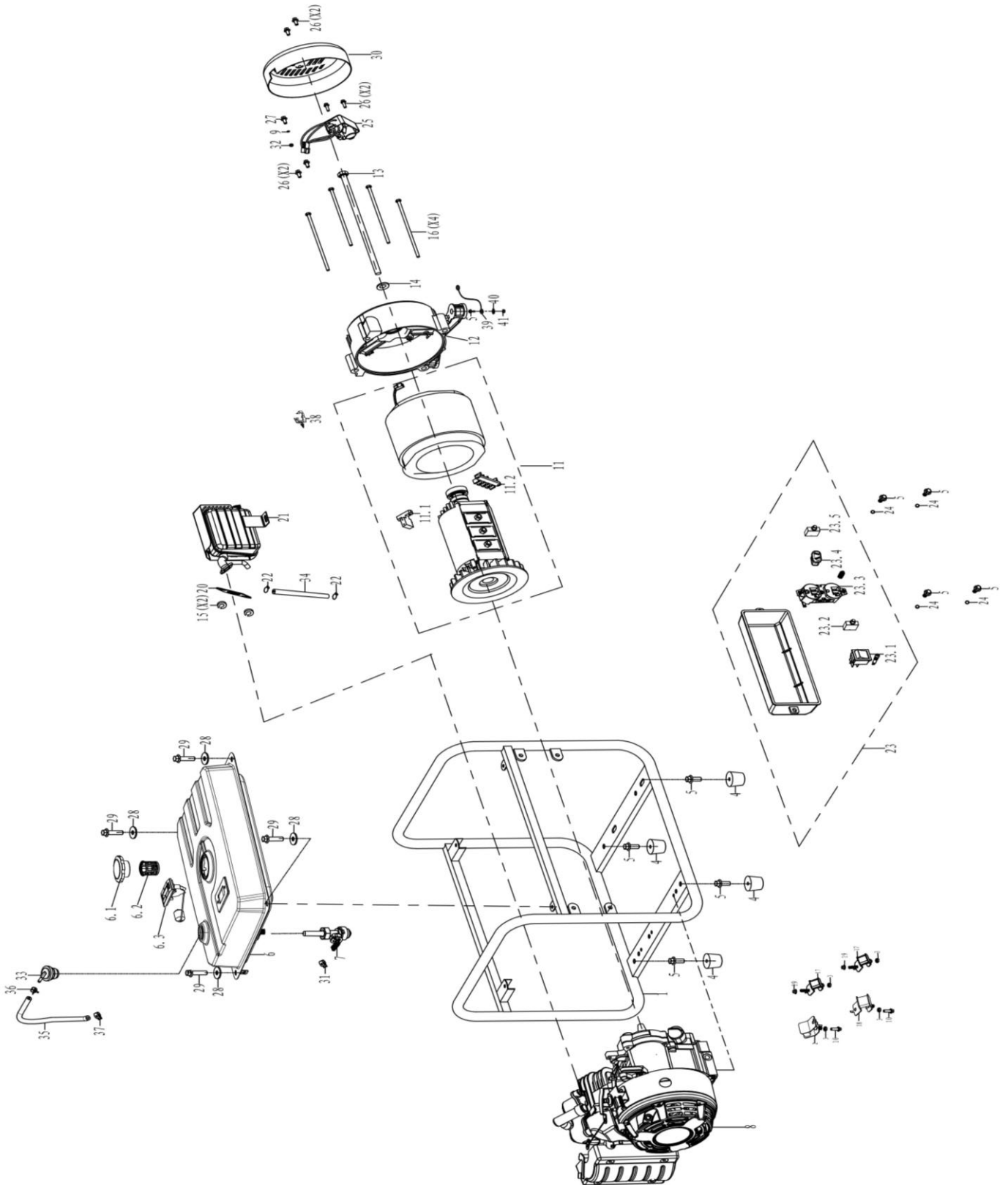

Parts List for Generator

Ref.	Part Number	Part Description	Qty.
1	770189-010	FRAME	1
2	531102	ISOLATOR A	1
3	90011	NUT M8 M8	4
4	531112	RUBBER DAMPING BRACKET	4
5	91325	BOLT M6X12	8
6	700114-010	FUEL TANK ASSEMBLY	1
6.1	6278	FUEL TANK CAP COMP	1
6.2	6280	FUEL FILTER	1
6.3	6279	FUEL GUAGE ASSY	1
7	518104	FUEL COCK	1
8	DG1500-IR-001E	ENGINE ASSEMBLY	1
9	94001	TOOTH TYPE GASKET $\phi 5$	1
10	91343	BOLT M8X16	2
11	751405	MOTOR ASSEMBLY	1
11.1	5099020	CARBON BRUSH COMP	1
11.2	6079	GROUNDING POST COMP	1
12	532102	MOTOR STAND	1
13	91703	BOLT	1
14	96812	GASKET, ROTOR BOLT $\phi 8.5 \times \phi 24 \times 3$	1
15	94204	SPRING WASHER $\phi 5$	2
16	91603	BOLT	4
17	531106	ISOLATOR B	2
18	531103	ISOLATOR B	1
19	90018	NUT M8	2
20	96033	PACKING, EXHAUST	1
21	705113	MUFFLER COMP	

Ref.	Part Number	Part Description	Qty.
22	599302	CLIP $\phi 12$	1
23	713515	PANEL COMP	1
23.1	34203-005	SWITCH ASSEMBLY	2
23.2	599923	THERMAL PROTECTOR 8A	1
23.3	34204-063	DOUBLE RECEPTACLE, AMERICA	23.3
23.4	6034	RECEPTACLE, ARGENTINA	23.4
23.5	6258	THERMAL PROTECTOR 12A	23.5
24	96120	WASHER	24
25	534105	AUTOMATIC VOLTAGE REGULATOR	25
26	91322	BOLT M5X12	26
27	91323	BOLT M5X16	27
28	96811	WASHER, FUEL TANK	28
29	91330	BOLT M6X20	29
30	533104-010	END COVER, GENERATOR	30
31	94403	CLIP, FUEL LINE $\phi 7.5$	31
32	94204	SPRING WASHER $\phi 5$	32
33	245405	MANUAL CHOKE ASSEMBLY	33
34	95902	BREATHER PIPE	34
35	95311	CONNECTING PIPE $\phi 4 \times \phi 10 \times 280 \text{mm}$	35
36	94408	CLIP, FUEL LINE $\phi 10$	36
37	94409	CLIP, FUEL LINE $\phi 9.5$	37
38	210801	CLIP	38
39	544301	CONNECT WIRE, FRAME	39
40	94002	TOOTH TYPE GASKET $\phi 6$	40
41	90016	NUT M6	41

Replacement Parts

- For replacement parts and technical questions, please call Customer Service at **1-877-234-6869**.
- Not all product components are available for replacement. The illustrations provided are a convenient reference to the location and position of parts in the assembly sequence.
- When ordering parts, the following information will be required: item description, item model number, item serial number/item lot date code, and the replacement part reference number.
- The distributor reserves the rights to make design changes and improvements to product lines and manuals without notice.

Limited Warranty

Northern Tool and Equipment Company, Inc. ("We" or "Us") warrants to the original purchaser only ("You" or "Your") that the Ironton product purchased will be free from material defects in both materials and workmanship, normal wear and tear excepted, for a period of 90 days from date of purchase. The foregoing warranty is valid only if the installation and use of the product is strictly in accordance with product instructions. There are no other warranties, express or implied, including the warranty of merchantability or fitness for a particular purpose. If the product does not comply with this limited warranty, Your sole and exclusive remedy is that We will, at our sole option and within a commercially reasonable time, either replace the product or product component without charge to You or refund the purchase price (less shipping). This limited warranty is not transferable.

Limitations on the Warranty

This limited warranty does not cover: (a) normal wear and tear; (b) damage through abuse, neglect, misuse, or as a result of any accident or in any other manner; (c) damage from misapplication, overloading, or improper installation; (d) improper maintenance and repair; and (e) product alteration in any manner by anyone other than Us, with the sole exception of alterations made pursuant to product instructions and in a workmanlike manner.

Obligations of Purchaser

You must retain Your product purchase receipt to verify date of purchase and that You are the original purchaser. To make a warranty claim, contact Us at 1-877-234-6869, identify the product by make and model number, and follow the claim instructions that will be provided. The product and the purchase receipt must be provided to Us in order to process Your warranty claim. Any returned product that is replaced or refunded by Us becomes our property. You will be responsible for return shipping costs or costs related to Your return visit to a retail store.

Remedy Limits

Product replacement or a refund of the purchase price is Your sole remedy under this limited warranty or any other warranty related to the product. We shall not be liable for: service or labor charges or damage to Your property incurred in removing or replacing the product; any damages, including, without limitation, damages to tangible personal property or personal injury, related to Your improper use, installation, or maintenance of the product or product component; or any indirect, incidental or consequential damages of any kind for any reason.

Assumption of Risk

You acknowledge and agree that any use of the product for any purpose other than the specified use(s) stated in the product instructions is at Your own risk.

Governing Law

This limited warranty gives You specific legal rights, and You also may have other rights which vary from state to state. Some states do not allow limitations or exclusions on implied warranties or incidental or consequential damages, so the above limitations may not apply to You. This limited warranty is governed by the laws of the State of Minnesota, without regard to rules pertaining to conflicts of law. The state courts located in Dakota County, Minnesota shall have exclusive jurisdiction for any disputes relating to this warranty.



Distributed by:

Northern Tool & Equipment Company, Inc.

Burnsville, Minnesota 55306

www.northerntool.com

Made in China